

ORDERING REPLACEMENT PARTS

To order replacement parts, call our Customer Service Department toll-free at 1-800-999-3756, Monday through Friday, 6 a.m. until 6 p.m. Mountain Time (excluding holidays). To help us assist you, please be prepared to give the following information:

- The MODEL NUMBER of the product (PFEX97571).
- The NAME of the product (PROFORM® 975s).
- The SERIAL NUMBER of the product (see the front cover of this manual).
- The KEY NUMBER and DESCRIPTION of the part(s) (see the PART LIST on page 14 of this manual).

PROFORM® is a registered trademark of ICON Health & Fitness, Inc.

LIMITED WARRANTY

ICON Health & Fitness, Inc. (ICON), warrants this product to be free from defects in workmanship and material, under normal use and service conditions, for a period of ninety (90) days from the date of purchase. This warranty extends only to the original purchaser. ICON's obligation under this warranty is limited to replacing or repairing, at ICON's option, the product through one of its authorized service centers. All repairs for which warranty claims are made must be pre-authorized by ICON. This warranty does not extend to any product or damage to a product caused by or attributable to freight damage, abuse, misuse, improper or abnormal usage or repairs not provided by an ICON authorized service center, products used for commercial or rental purposes, or products used as store display models. No other warranty beyond that specifically set forth above is authorized by ICON.

ICON is not responsible or liable for indirect, special or consequential damages arising out of or in connection with the use or performance of the product or damages with respect to any economic loss, loss of property, loss of revenues or profits, loss of enjoyment or use, costs of removal, installation or other consequential damages of whatsoever nature. Some states do not allow the exclusion or limitation of incidental or consequential damages. Accordingly, the above limitation may not apply to you.

The warranty extended hereunder is in lieu of any and all other warranties and any implied warranties of merchantability or fitness for a particular purpose is limited in its scope and duration to the terms set forth herein. Some states do not allow limitations on how long an implied warranty lasts. Accordingly, the above limitation may not apply to you.

This warranty gives you specific legal rights. You may also have other rights which vary from state to state.

ICON HEALTH & FITNESS, INC., 1500 S. 1000 W., LOGAN, UT 84321-9813

PRO-FORM® 975s

Model No. PFEX97571

Serial No. _____

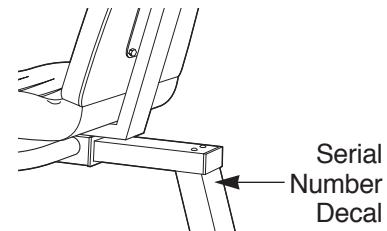

QUESTIONS?

As a manufacturer, we are committed to providing complete customer satisfaction. If you have questions, or if there are missing or damaged parts, we will guarantee complete satisfaction through direct assistance from our factory.

TO AVOID UNNECESSARY DELAYS, PLEASE CALL DIRECT TO OUR TOLL-FREE CUSTOMER HOT LINE. The trained technicians on our customer hot line will provide immediate assistance, free of charge to you.

CUSTOMER HOT LINE:
1-800-999-3756
Mon.-Fri., 6 a.m.-6 p.m. MST

CAUTION

Read all precautions and instructions in this manual before using this equipment. Keep this manual for future reference.

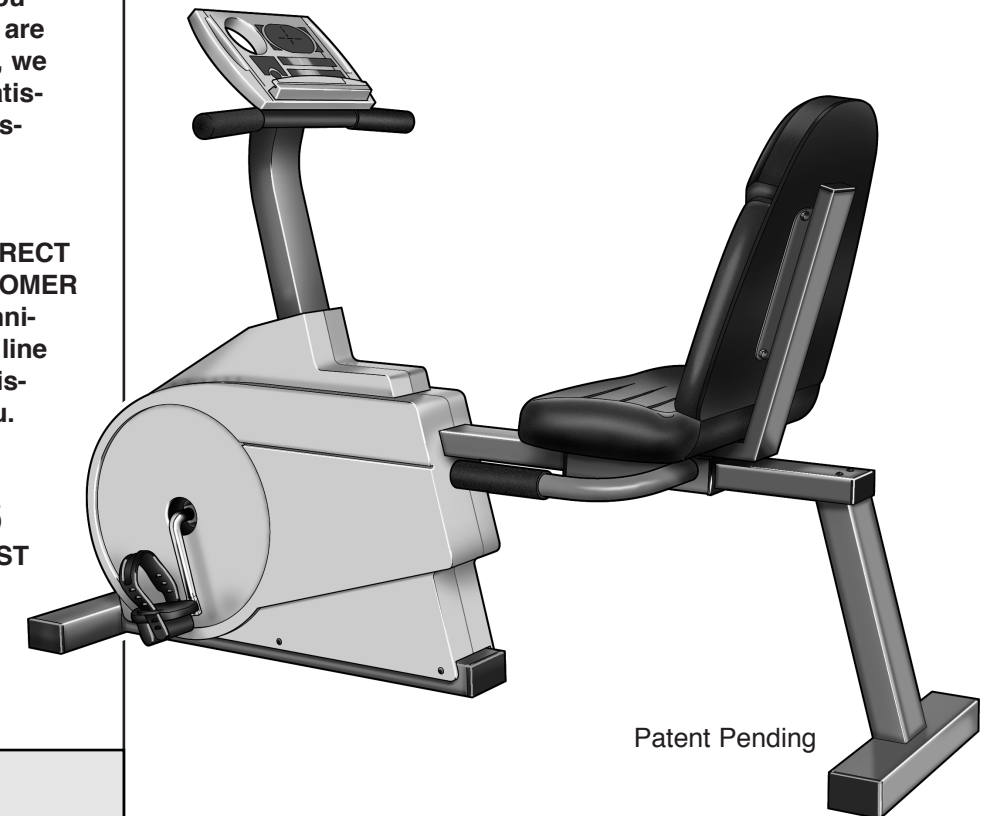

USER'S MANUAL

TABLE OF CONTENTS

IMPORTANT PRECAUTIONS	2
BEFORE YOU BEGIN	3
ASSEMBLY	4
HOW TO USE THE PROFORM® 975S	8
HOW TO USE THE PULSE SENSOR	11
MAINTENANCE AND STORAGE	12
CONDITIONING GUIDELINES	13
PART LIST	14
EXPLODED DRAWING	15
ORDERING REPLACEMENT PARTS	Back Cover
LIMITED WARRANTY	Back Cover

EXPLODED DRAWING—Model No. PFEX97571

R0198A

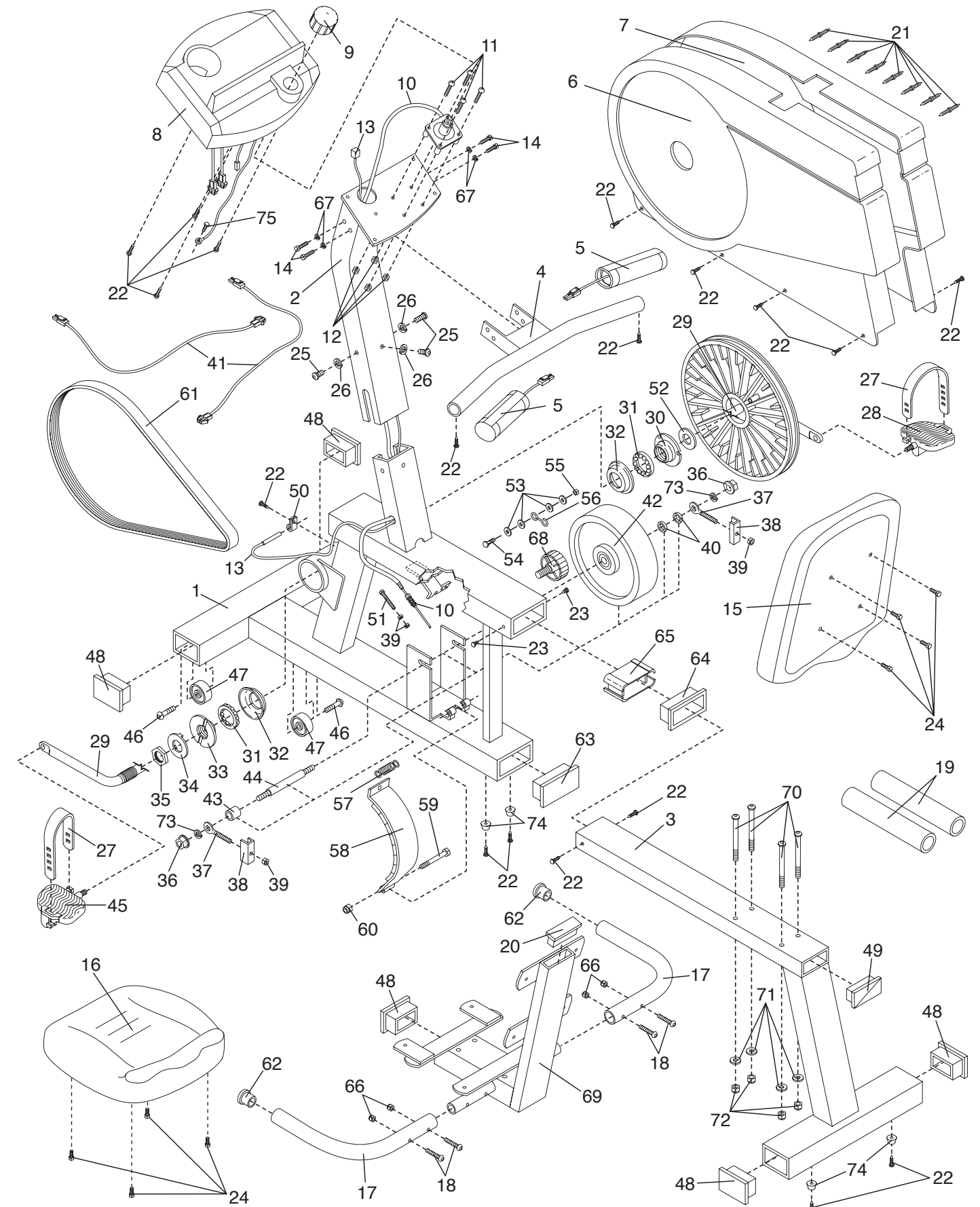

IMPORTANT PRECAUTIONS

WARNING: To reduce the risk of serious injury, read the following important precautions before using the PROFORM® 975s.

1. Read all instructions in this manual before using the 975s.
2. It is the responsibility of the owner to ensure that all users of the 975s are adequately informed of all precautions. Use the 975s only as described in this manual.
3. Use the 975s indoors on a level surface. Keep the 975s away from moisture and dust. Place a mat under the 975s to protect the floor or carpet.
4. Inspect and tighten all parts regularly. Replace any worn parts immediately.
5. Keep children under the age of 12 and pets away from the 975s at all times.
6. The 975s should not be used by persons weighing more than 250 pounds.
7. Wear appropriate clothing when exercising; do not wear loose clothing that could become caught on the 975s. Always wear athletic shoes when using the 975s.
8. Always keep your back straight when using the 975s. Do not arch your back.
9. If you feel pain or dizziness at any time while exercising, stop immediately and begin cooling down.
10. The 975s is intended for in-home use only. Do not use the 975s in a commercial, rental, or institutional setting.
11. **CAUTION DECAL PLACEMENT:** The decal shown below has been placed on the 975s. If the decal is missing, or if it is not legible, please call our Customer Service Department toll-free at 1-800-999-3756 to order a free replacement decal. Apply the decal in the location shown.

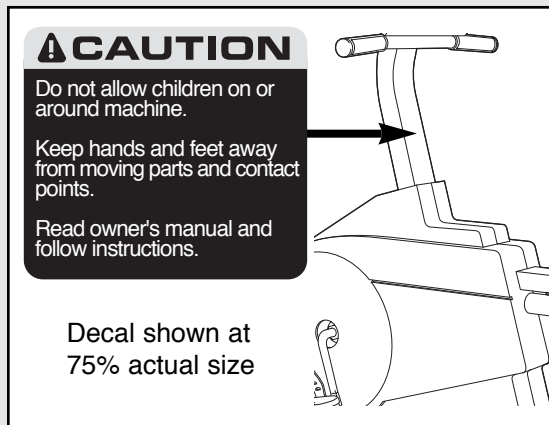

WARNING: Before beginning this or any exercise program, consult your physician. This is especially important for persons over the age of 35 or persons with pre-existing health problems. Read all instructions before using. ICON assumes no responsibility for personal injury or property damage sustained by or through the use of this product.

PART LIST—Model No. PFEX97571

R0198A

Key No.	Qty.	Description	Key No.	Qty.	Description
1	1	Frame	40	2	M10 Washer
2	1	Upright	41	2	Extension Wire
3	1	Seat Frame	42	1	Flywheel
4	1	Handlebar	43	1	10mm x 13mm Spacer
5	2	Pulse Grip	44	1	Flywheel Axle
6	1	Left Side Shield	45	1	Left Pedal
7	1	Right Side Shield	46	2	M10 x 52mm Button Head Screw
8	1	Console	47	2	Wheel
9	1	Resistance Knob	48	5	2" x 3" Endcap
10	1	Resistance Cable/Control	49	1	1 1/2" x 3" Endcap
11	4	M5 x 30mm Screw	50	1	Cable Clamp
12	4	M5 Nut	51	1	M6 x 56mm Bolt
13	1	Reed Switch/Wire	52	1	Large Flat Washer
14	4	M6 x 25mm Hex Head Screw	53	4	#8 Flat Washer
15	1	Backrest	54	1	Clamp Bolt
16	1	Seat	55	1	Clamp Nut
17	2	Seat Handle	56	1	Resistance Hook
18	4	M6 x 38mm Button Head Bolt	57	1	Resistance Spring
19	2	Foam Handle Grip	58	1	Magnet Bracket
20	1	1" x 3" Endcap	59	1	M8 x 65mm Hex Head Bolt
21	8	Tree Fastener	60	1	M8 Nylon Locknut
22	21	#8 x 5/8" Screw	61	1	Drive Belt
23	2	#8 x 3/8" Screw	62	2	1 1/4" Round Endcap
24	8	M6 x 16mm Hex Head Screw	63	1	2" x 4" Endcap
25	3	M10 x 25mm Button Head Screw	64	1	Frame Bushing
26	3	M10 Split Washer	65	1	Seat Frame Bushing
27	2	Pedal Strap	66	4	M6 Nylon Locknut
28	1	Right Pedal	67	4	M6 Split Washer
29	1	Crank/Pulley	68	1	Lock Knob
30	1	Notched Bearing Nut	69	1	Seat Bracket
31	2	Bearing	70	4	M10 x 105mm Button Head Bolt
32	2	Bearing Cup	71	4	M10 Flat Washer
33	1	Slotted Bearing Nut	72	4	M10 Nylon Locknut
34	1	Crank Washer	73	2	M8 Split Washer
35	1	Crank Nut	74	4	Rubber Bumper
36	2	M8 Flanged Hex Nut	75	1	M4 x 16mm Screw
37	2	M6 Eyebolt	#	1	User's Manual
38	2	Adjustment Bracket	#	1	4mm Allen Wrench
39	4	M6 Nut	#	1	5.5mm Allen Wrench

Note: “#” indicates a non-illustrated part. Specifications are subject to change without notice. See the back cover of this manual for information about ordering replacement parts.

BEFORE YOU BEGIN

Thank you for selecting the innovative PROFORM® 975s. The PROFORM 975s offers a unique form of low-impact exercise that offers greater cardiovascular benefits and increased muscle toning. The 975s features adjustable resistance to let you tailor your exercise to the level that's perfect for you. And when you're not exercising, the 975s can be folded for compact storage.

For your benefit, read this manual carefully before you use the PROFORM 975s. If you have additional questions, please call our Customer Service

Department toll-free at 1-800-999-3756, Monday through Friday, 6 a.m. until 6 p.m. Mountain Time (excluding holidays). To help us assist you, please mention the product model number and serial number when calling. The model number is PFEX97571. The serial number can be found on a decal attached to the 975s (see the front cover of this manual for the location of the decal).

Before reading further, please look at the drawing below and familiarize yourself with the parts that are labeled.

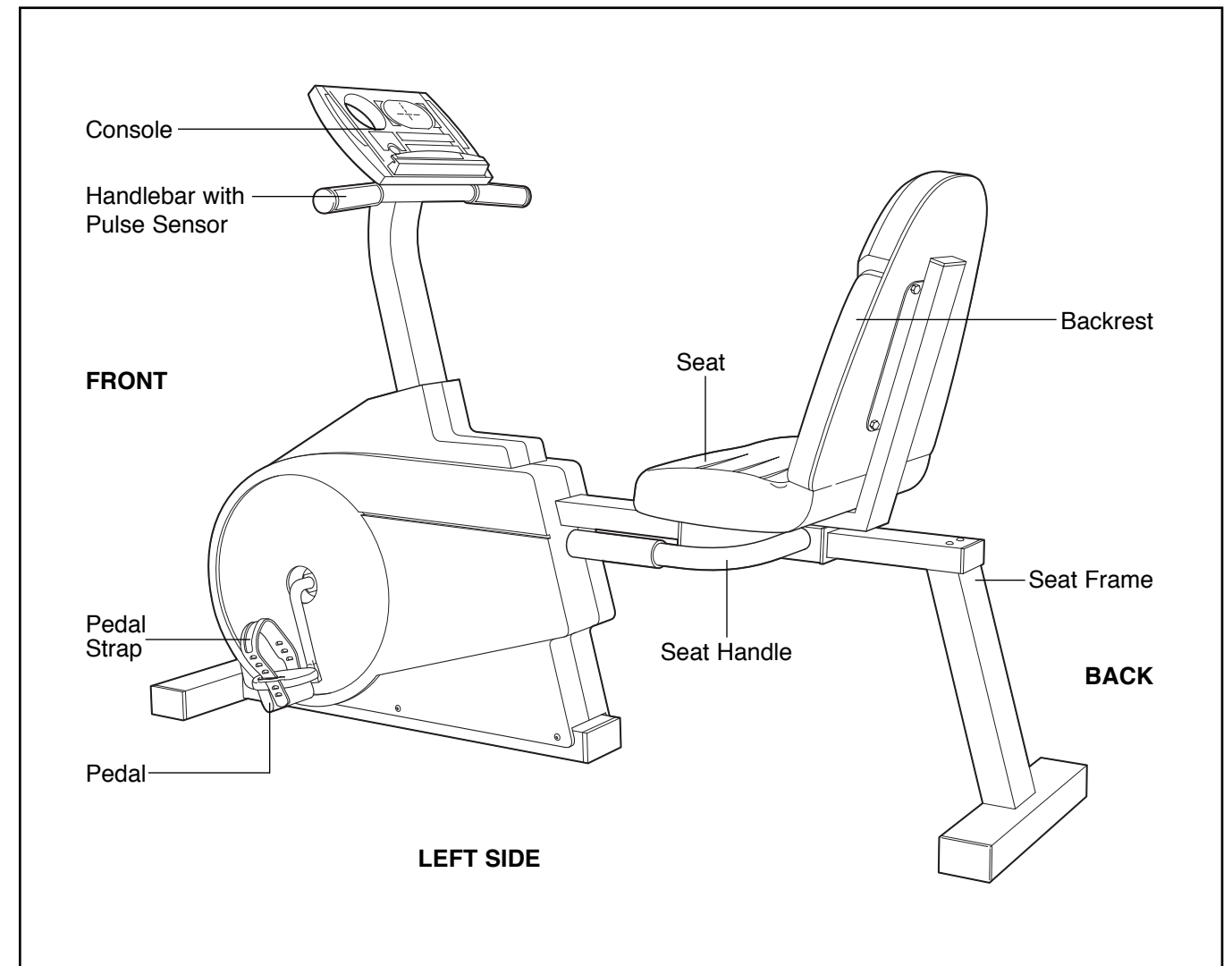

ASSEMBLY

Place all parts of the PROFORM® 975s in a cleared area and remove the packing materials. **Do not dispose of the packing materials until assembly is completed.**

Assembly requires the included tools and your own adjustable wrench .

PART CHART

Use the part drawings below to identify the small parts used in assembly. The number in parenthesis below each drawing refers to the key number of the part. The second number refers to the quantity used in assembly. **Note: Some small parts may have been pre-attached for shipping. If a part is not in the parts bag, check to see if it has been pre-assembled.**

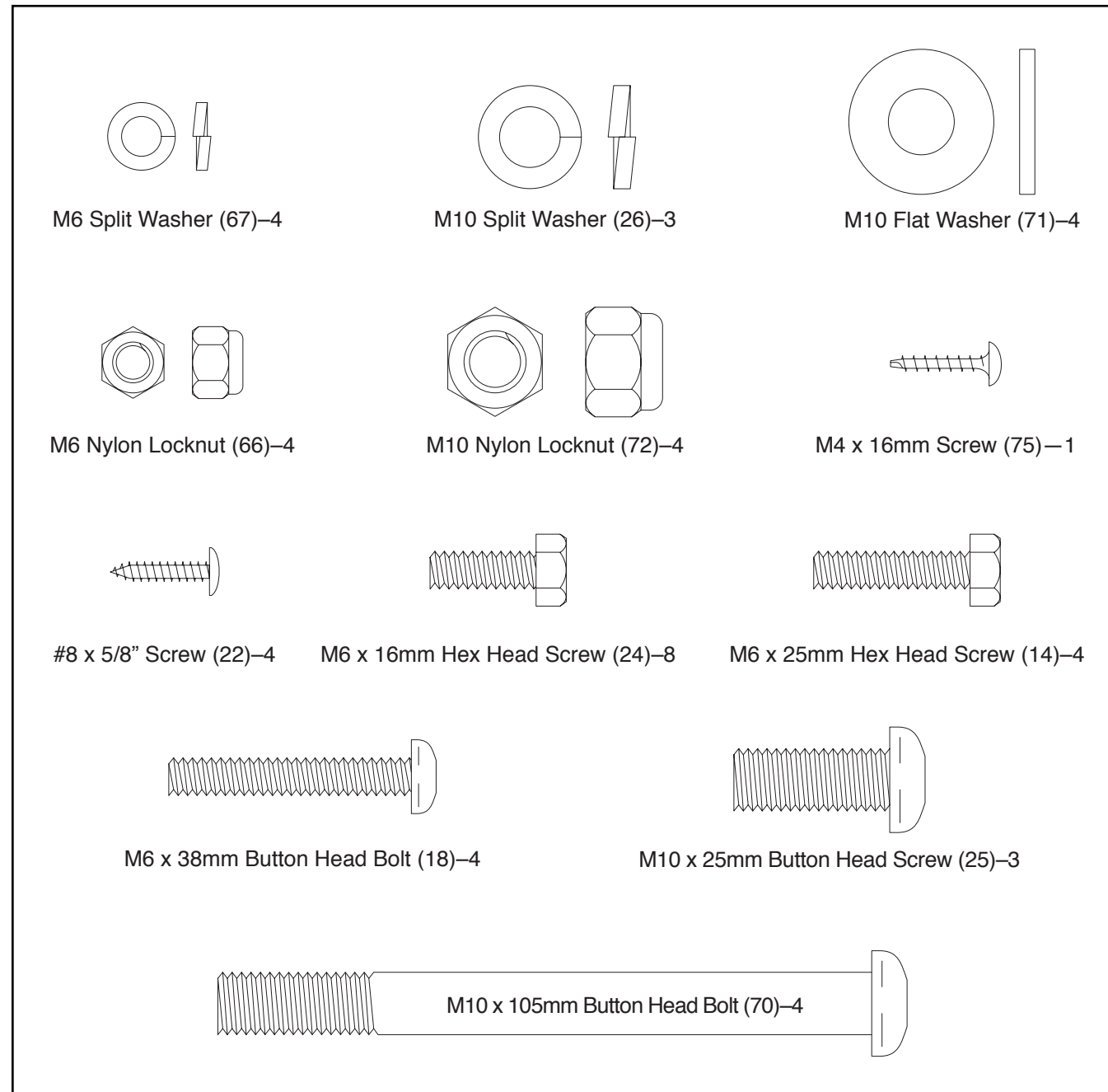

CONDITIONING GUIDELINES

The following guidelines will help you to plan your exercise program. Remember that proper nutrition and adequate rest are essential for successful results.

WARNING: Before beginning this or any exercise program, consult your physician. This is especially important for individuals over the age of 35 or individuals with pre-existing health problems.

WHY EXERCISE?

Exercise has proven essential for good health and general well-being. Regular participation in a well-rounded exercise program results in a stronger and more efficient heart, improved respiratory function, increased stamina and endurance, better weight management and body fat control, increased ability to deal with stress, and greater self-esteem and confidence.

EXERCISE INTENSITY

To maximize the benefits of exercising, it is important to exercise with the proper intensity. The proper intensity level can be found by using your heart rate as a guide. For effective aerobic exercise, your heart rate should be maintained at a level between 70% and 85% of your maximum heart rate as you exercise. This is known as your training zone. You can find your training zone in the table below. Training zones are listed according to age and physical condition.

AGE	TRAINING ZONE (BEATS/MIN.)	
	UNCONDITIONED	CONDITIONED
20	138–167	133–162
25	136–166	132–160
30	135–164	130–158
35	134–162	129–156
40	132–161	127–155
45	131–159	125–153
50	129–156	124–150
55	127–155	122–149
60	126–153	121–147
65	125–151	119–145
70	123–150	118–144
75	122–147	117–142
80	120–146	115–140
85	118–144	114–139

During the first few months of your exercise program, keep your heart rate near the low end of your training zone as you exercise. After a few months of regular exercise, your heart rate can be increased gradually until it is near the middle of your training zone as you exercise.

To measure your heart rate, use the pulse sensor in the handlebar. You can also measure your pulse by placing two fingers on your wrist. Stop exercising and take a six-second heartbeat count. Multiply the result by ten to find your heart rate. (A six-second count is used because your heart rate drops quickly when you stop exercising.)

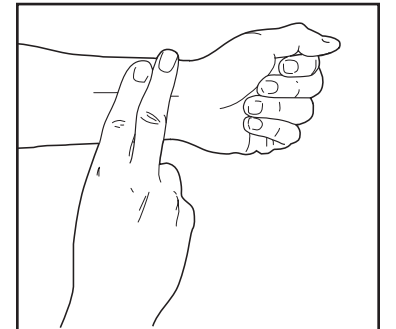

If your heart rate is too high, decrease the intensity of your exercise. If your heart rate is too low, increase the intensity of your exercise.

WORKOUT GUIDELINES

A well-rounded workout includes the following three phases:

A warm-up phase, lasting 5 to 10 minutes. Begin with slow, controlled stretches, and progress to more rhythmic stretches. This will increase the body temperature, heart rate, and circulation in preparation for strenuous exercise.

A cardiovascular phase, including 20 to 30 minutes of exercising with your heart rate in your training zone.

A cool-down phase, consisting of 5 to 10 minutes of stretching. Thorough stretching offsets muscle contractions and other problems caused when you stop exercising suddenly. Stretching for increased flexibility is often most effective during this phase. This phase should leave you relaxed and comfortably tired.

To maintain or improve your condition, complete three workouts each week, with at least one day of rest between workouts. After a few months of regular exercise, you may complete up to five workouts each week, if desired. Find the best time of day for your workouts, and then stick with it.

Remember, the key to success is to make exercise a regular and enjoyable part of your everyday life.

MAINTENANCE AND STORAGE

Inspect and tighten all parts of the PROFORM® 975s regularly. The 975s can be cleaned with a soft, damp cloth. To prevent damage to the console, keep liquids away and keep the console out of direct sunlight.

BATTERY REPLACEMENT

If the console does not function properly, the batteries should be replaced. To replace the batteries, refer to assembly step 11 on page 7.

CRANK ADJUSTMENT

If the arms of the Crank (14) become loose, they should be tightened in order to prevent excessive wear. Loosen the Crank Nut (35) on the left arm of the Crank. Place the end of a standard screw-

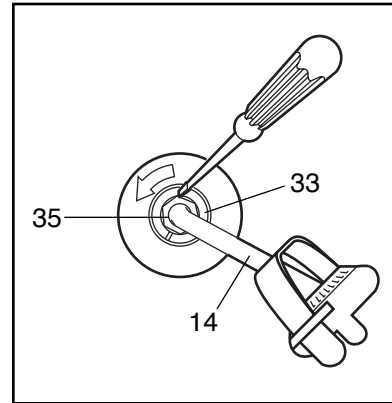

driver in one of the slots in the Slotted Bearing Nut (33). Lightly tap the screwdriver with a hammer to turn the Slotted Bearing Nut counterclockwise until the arms are no longer loose. **Do not overtighten the Slotted Bearing Nut.** When the Slotted Bearing Nut is properly tightened, tighten the Crank Nut.

HOW TO STORE THE PROFORM® 975S

When the PROFORM® 975s is not in use, it can be folded for compact storage. Refer to the drawing at the right. Loosen the Lock Knob (68) on the right side of the Frame (1). Slide the Seat Frame (3) as far into the Frame as it will go. Tighten the Lock Knob. Store the PROFORM® 975s indoors, away from moisture and dust.

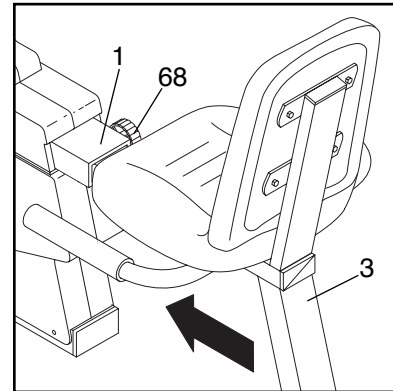

1. Loosen the Lock Knob (68) on the right side of the Frame (1). Slide the Seat Frame (3) out until it stops. Tighten the Lock Knob.

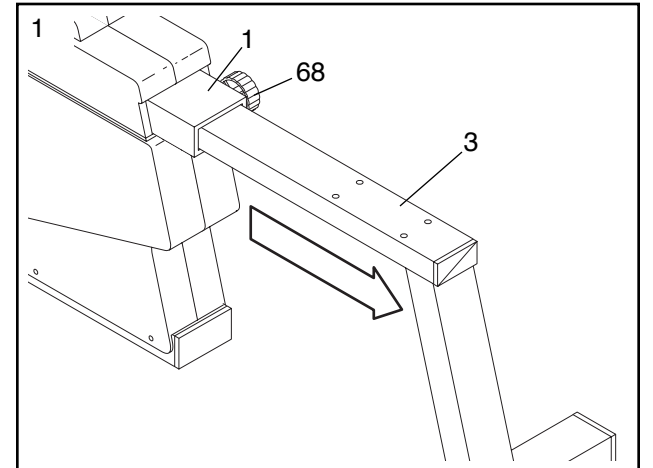

2. Attach the Upright (2) to the Frame (1) with three M10 x 25mm Button Head Screws (25) and three M10 Split Washers (26). **Be careful not to pinch the Reed Switch Wire (13) or the Resistance Cable (10).**

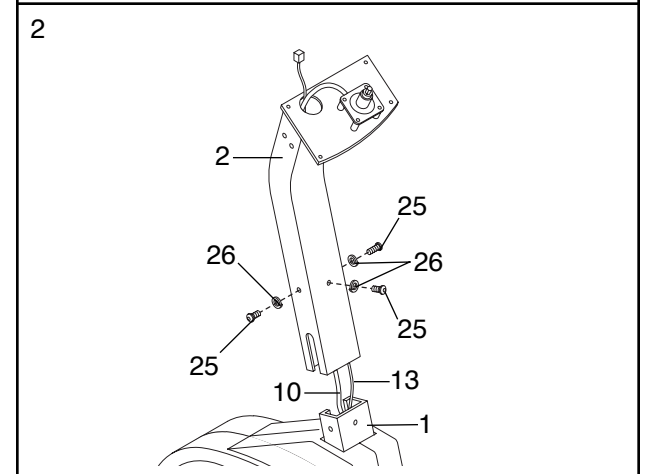

3. Route both Extension Wires (41) up through the Upright (2) as shown.

Attach the Handlebar (4) to the Upright (2) with two M6 x 25mm Hex Head Screws (14) and two M6 Split Washers (67), **but do not tighten the Screws yet.** Make sure that the Screws are threaded into the indicated holes. **Note: Two additional Screws will be attached in step 5.**

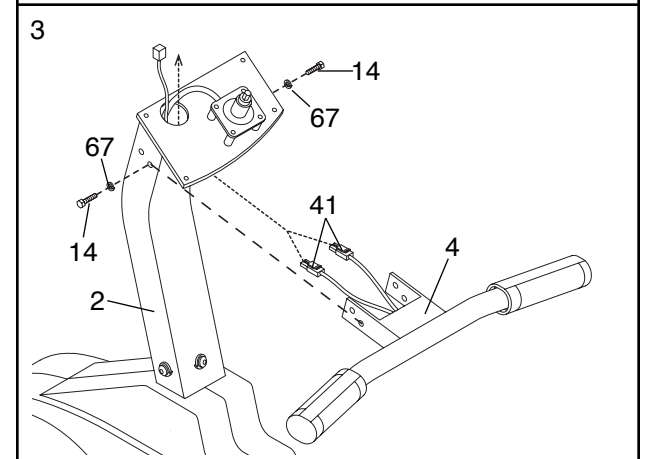

4. Connect the Reed Switch Wire (13) and the two Extension Wires (41) to the corresponding wires on the Console (8).

Attach the ground wire to the Upright (2) with an M4 x 16mm Screw (75).

Attach the Console (8) to the Upright (2) with four #8 x 5/8" Screws (22).

Press the Resistance Knob (9) onto the Resistance Control (10). Be sure that the mark on the Knob is correctly aligned.

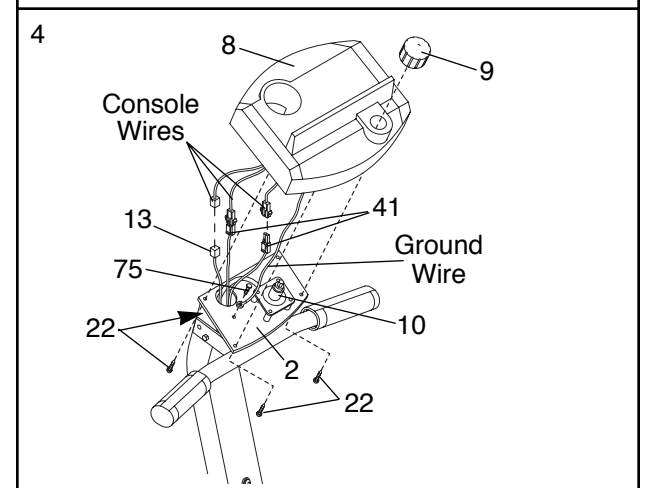

5. Finish attaching the Handlebar (4) to the Upright (2) with two more M6 x 25mm Hex Head Screws (14) and two more M6 Split Washers (67). **Tighten all four Hex Head Screws.**

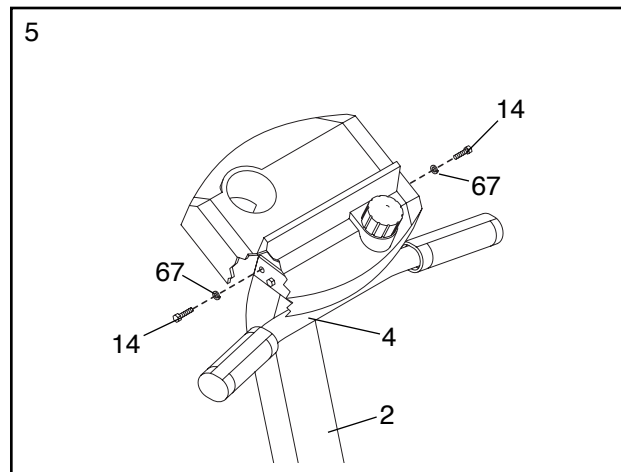

6. Attach the Seat Bracket (69) to the Seat Frame (3) with four M10 x 105mm Button Head Bolts (70), four M10 Flat Washers (71), and four M10 Nylon Locknuts (72).

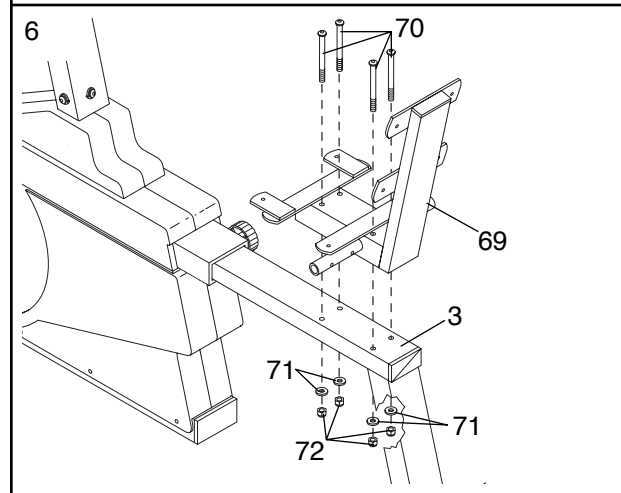

7. Attach the Seat (16) to the Seat Bracket (69) with four M6 x 16mm Hex Head Screws (24).

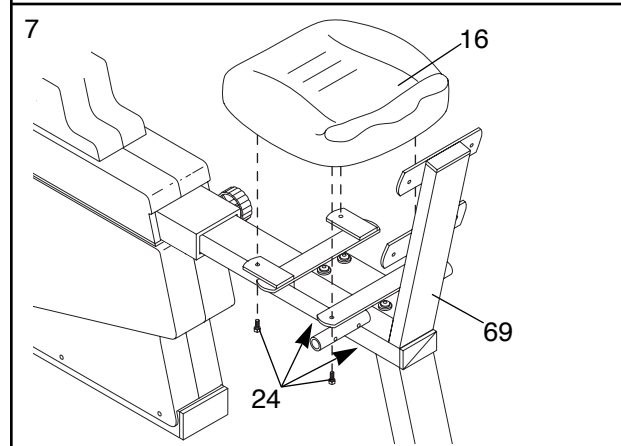

8. Attach a Seat Handle (17) to the Seat Bracket (69) with two M6 x 38mm Button Head Bolts (18) and two M6 Nylon Locknuts (66).

Attach the other Seat Handle (17) to the Seat Bracket (69) in the same manner.

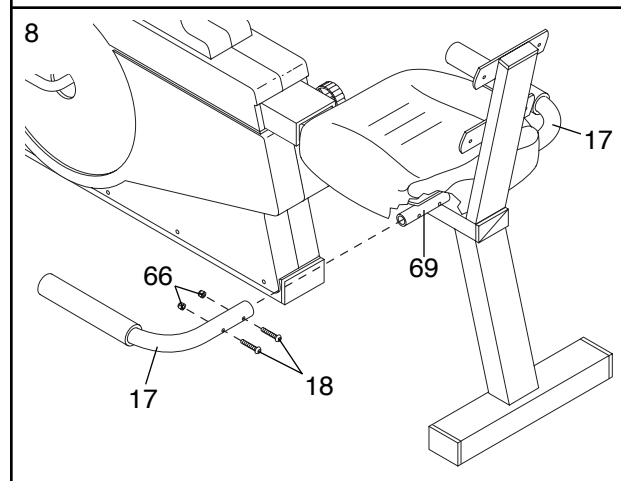

HOW TO USE THE PULSE SENSOR

The convenient pulse sensor allows you to measure your heart rate periodically. You can measure your heart rate before you begin exercising, during your workout, and again when you finish.

To use the pulse sensor, first make sure that the power is turned on. Stop exercising, rest both feet on the floor, and place your hands on the metal contacts. Your palms must be resting on the inner contacts and your fingers must be touching the outer contacts. Avoid moving your hands. After a moment, the heart indicator in the PULSE display will flash and your heart rate will be shown. For the most accurate heart rate reading, continue to hold the contacts for about 15 seconds.

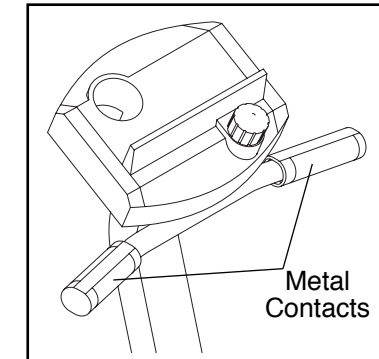

HAND PULSE SENSOR TROUBLE-SHOOTING

- Avoid moving your hands while using the pulse sensor. Excessive movement may interfere with heart rate readings. If the pulse sensor is not used correctly, the heart indicator will flash repeatedly in the PULSE display but your heart rate will not be shown.

- If an "L" appears in the PULSE display, then the pulse sensor received too little pulse information to accurately calculate your pulse. Let go of the metal contacts; then place your hands on the contacts again. Your palms must be resting on the inner contacts and your fingers must be touching the outer contacts.
- If an "H" appears in the PULSE display, then the pulse sensor received too much pulse information to accurately calculate your pulse. Let go of the metal contacts; then place your hands on the contacts again. Your palms must be resting on the inner contacts and your fingers must be touching the outer contacts.
- Do not hold the metal contacts too tightly; doing so may interfere with heart rate readings.
- Do not move your hands while you hold the metal contacts; your muscle movement may interfere with heart rate readings.
- For the most accurate heart rate reading, wait for about 15 seconds.
- For optimal performance of the pulse sensor, keep the metal contacts clean. The contacts can be cleaned with a soft cloth—never use alcohol, abrasives, or chemicals.

- Distance (DIST)—This mode shows the total number of miles you have cycled, up to 999. The display will then reset to zero and continue counting.
- Laps—This mode shows the number of quarter-mile laps you have completed.
- Calories (CAL)—This mode shows the approximate number of calories you have burned.

STEP-BY-STEP CONSOLE OPERATION

Before the console can be operated, two “AA” batteries must be installed. (See assembly step 11 on page 7 for installation instructions.) Follow the steps below to operate the console.

1 Turn on the power

To turn on the power, press the on/reset button or simply begin exercising. When the power is turned on, the entire display will appear for two seconds. The console will then be ready for use. Note: If batteries were just installed, the power will already be on.

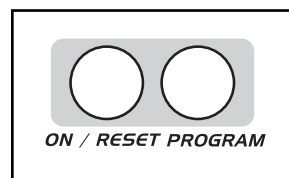

2 Select one of the three pacer programs or the manual mode

When the power is first turned on, the console will be in the manual mode. To select one of the pacer programs, repeatedly press the program button. The program indicator will show which program you have selected. The programs will be selected in the following order: the manual mode, the 6 MPH/30 RPM program, the 12 MPH/60 RPM program, and the 18 MPH/90 RPM program. Note: Once you select a pacer program, you can reselect the manual mode by repeatedly pressing the program button.

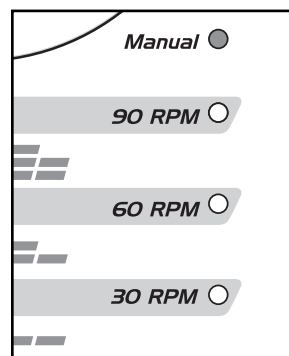

3 Begin your workout

If you selected the manual mode, one indicator on the inner P.A.C.E.R. track will light. As you exercise, this indicator will move around the quarter-mile track.

If you selected a pacer program, two indicators on the P.A.C.E.R. track will light. The indicator on the inner track will show your actual pace. The indicator on the outer track

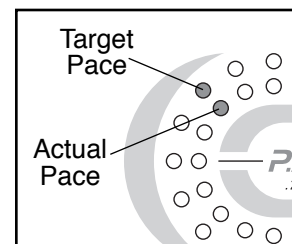

will move around the track at the programmed pace. As you exercise, adjust your pace so that the indicators on the inner and outer tracks remain even. As the program progresses, the target pace will change periodically; as the target pace changes, you should also adjust your pace. **Important: The target pace is a goal pace. Your actual pace may be slower than the target pace, especially during the first few months of your exercise program. Be sure to exercise at a pace that is comfortable for you.**

4 Follow your progress with the monitor modes

When the power is turned on, the console will scan through the five modes automatically. A flashing mode indicator will show which mode is currently displayed. When the Laps mode is displayed, an “L” will also appear. If desired, the display can be reset by pressing the on/reset button.

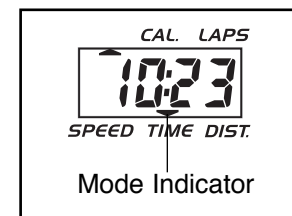

The PROFORM® 975s also features an innovative hand-grip pulse sensor. The pulse display allows you to monitor your heart rate during your workout. To use the pulse sensor, see page 11.

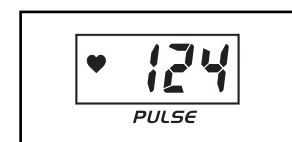

5 Turn off the power

To turn off the power, simply wait for about six minutes. If the pedals are not moved and the console buttons are not pressed for six minutes, the power will turn off automatically.

9. Attach the Backrest (15) to the Seat Bracket (69) with four M6 x 16mm Hex Head Screws (24).

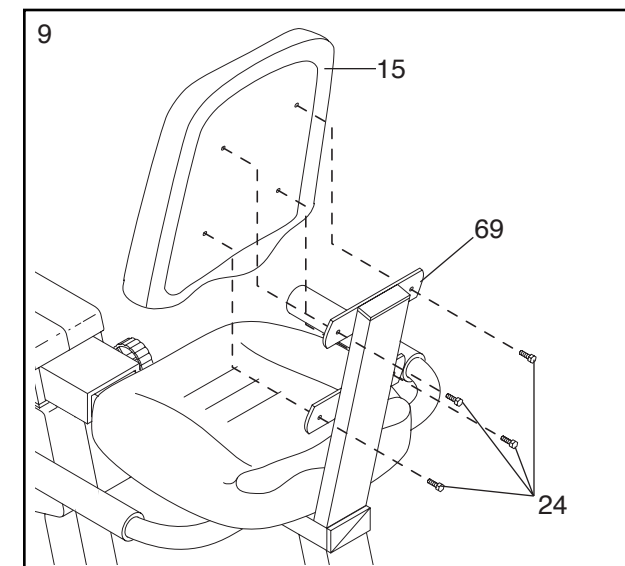

10. Identify the Left Pedal (45) (there is an “L” on the Left Pedal for identification). Using an adjustable wrench, tighten the Left Pedal counterclockwise into the left arm of the Crank (29).

Tighten the Right Pedal (not shown) clockwise into the right arm of the Crank (29).

Adjust the Pedal Strap (27) on the Left Pedal (45) to the desired position. Press the Pedal Strap onto the adjustment tab on the Left Pedal.

Adjust the Pedal Strap on the Right Pedal (not shown) in the same manner.

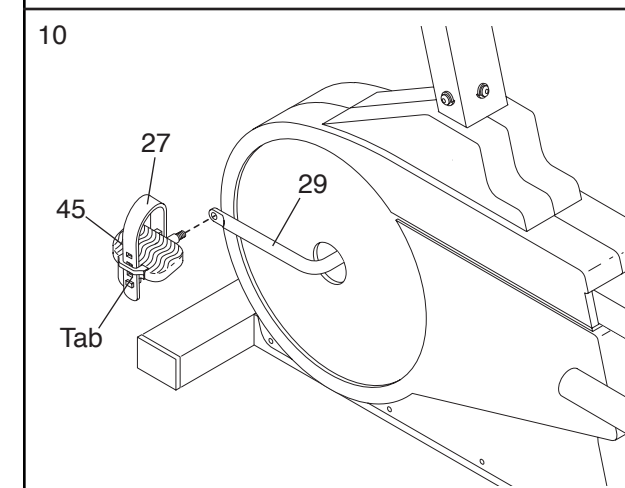

11. The Console (8) requires two “AA” batteries (not included)—alkaline batteries are recommended. Open the battery cover (not shown) on the back of the Console. Press two batteries into the battery clip. **Make sure that the negative (–) ends of the batteries are touching the springs.** Close the battery cover.

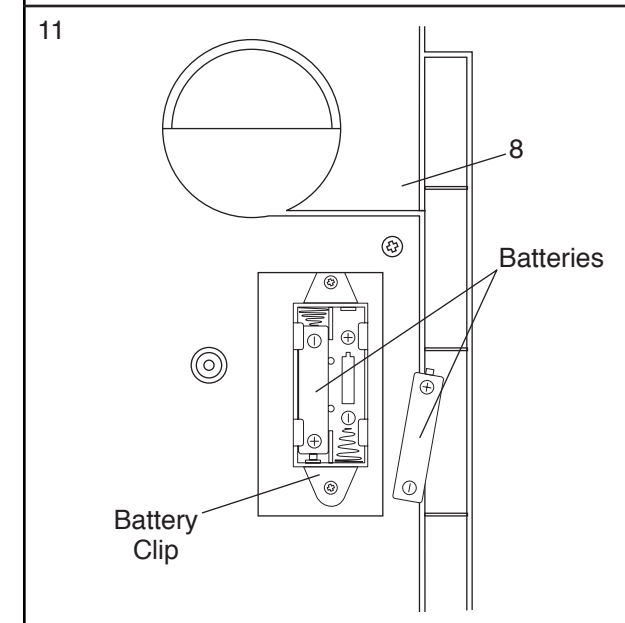

12. Make sure that all parts are properly tightened before you use the PROFORM® 975s.

HOW TO USE THE PROFORM® 975S

HOW TO ADJUST THE POSITION OF THE SEAT FRAME

The Seat Frame (3) can be adjusted to the position that is the most comfortable for you. To adjust the Seat Frame, first loosen the Lock Knob (68) on the right side of the Frame (1). Slide the Seat Frame forward or backward to the desired position. Tighten the Lock Knob.

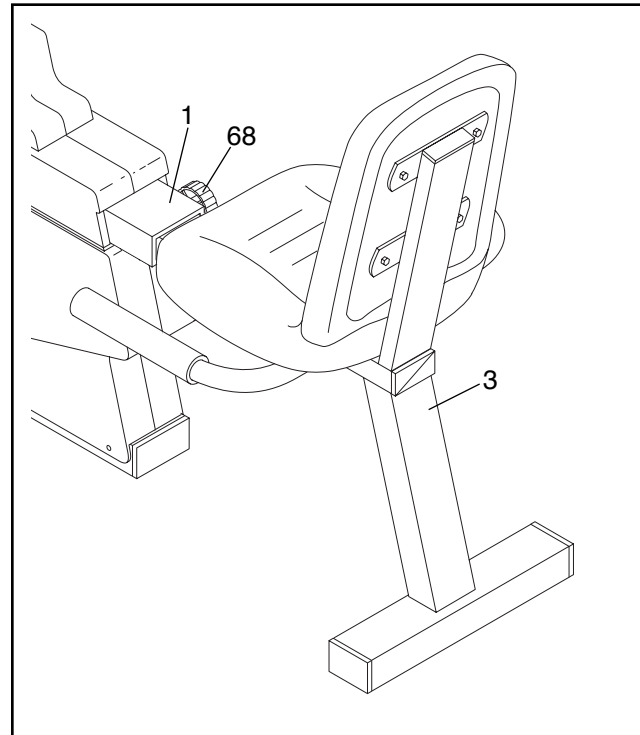

HOW TO ADJUST THE PEDAL STRAPS

To adjust each Pedal Strap (27), first pull the end of the Pedal Strap off the adjustment tab on the Pedal (45). Align a different hole in the Pedal Strap with the adjustment tab. Press the Pedal Strap onto the adjustment tab.

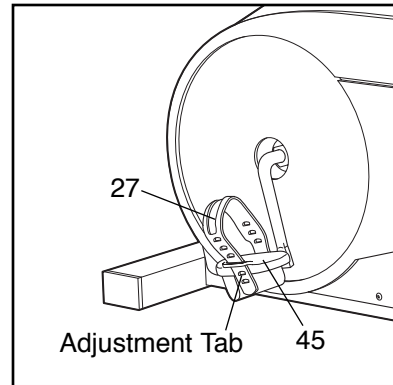

HOW TO ADJUST THE PEDALING RESISTANCE

The pedaling resistance can be adjusted with the Resistance Knob (9) located on the Console (8). To increase the resistance, turn the Resistance Knob clockwise; to decrease the resistance, turn the Resistance Knob counterclockwise.

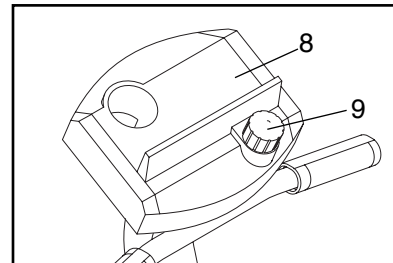
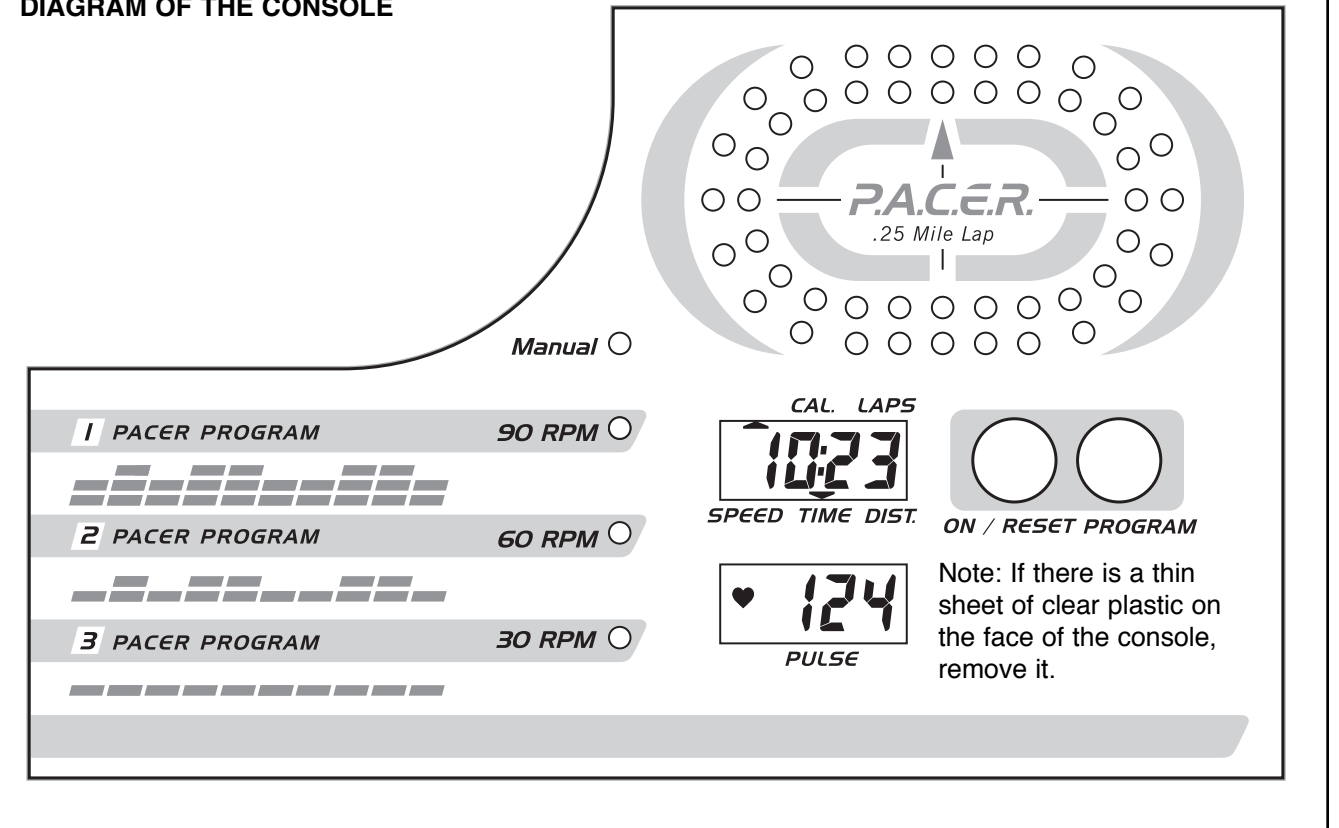

DIAGRAM OF THE CONSOLE



DESCRIPTION OF THE CONSOLE

The innovative console offers a manual mode and three pacer programs. The pacer programs are designed to help you achieve your exercise goals by pacing your exercise. The programs include an 18 MPH/90 RPM program, a 12 MPH/60 RPM program, and a 6 MPH/30 RPM program. The console also features five monitor modes that provide continuous exercise feedback. **Note: On some consoles the programs are listed in MPH and on others in RPM. Both sets of programs are identical.**

HOW THE PACER PROGRAMS OPERATE

When you use a pacer program, an indicator will light on each track of the P.A.C.E.R. display. The outer track shows a target pace; the inner track will show your actual pace.

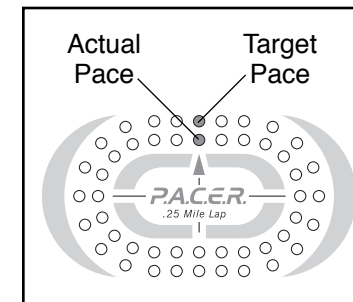

The target pace will change periodically during the 18 MPH/90 RPM and 12 MPH/60 RPM programs; as the target pace changes, simply adjust your pace to keep both indica-

tors even. **Important: The target pace is a goal pace. Your actual pace may be slower than the target pace, especially during the first few months of your exercise program. Be sure to exercise at a pace that is comfortable for you.**

The graphs on the left side of the console show how the target pace will change during each program (see the drawing above). Each graph is divided into ten columns, and each column represents 1/10 of a mile. The bars in each column show what the target pace will be during that 1/10 of a mile. For example, in the first column of the 12 MPH/60 RPM graph, there is one bar. This shows that during the first 1/10 of a mile in this program, the target pace will be 6 MPH (30 RPM). In the second column, there are two bars, indicating that the pace is now 12 MPH (60 RPM).

DESCRIPTION OF THE MONITOR MODES

The five monitor modes provide continuous exercise feedback. The modes are described below.

- Speed—This mode shows your pace, in miles per hour.
- Time—This mode counts the length of time you have exercised. Note: If you stop exercising for ten seconds or longer, the time mode will pause.

Free Manuals Download Website

<http://myh66.com>

<http://usermanuals.us>

<http://www.somanuals.com>

<http://www.4manuals.cc>

<http://www.manual-lib.com>

<http://www.404manual.com>

<http://www.luxmanual.com>

<http://aubethermostatmanual.com>

Golf course search by state

<http://golfingnear.com>

Email search by domain

<http://emailbydomain.com>

Auto manuals search

<http://auto.somanuals.com>

TV manuals search

<http://tv.somanuals.com>