

# PRO·FORM® *Light Cycle*

Model No. PFRX35390

Serial No. \_\_\_\_\_

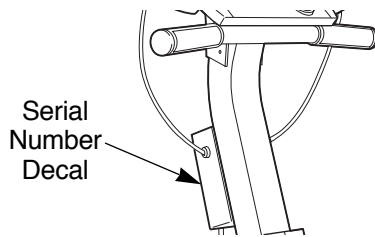

## USER'S MANUAL

### QUESTIONS?

As a manufacturer, we are committed to providing complete customer satisfaction. If you have questions, or if there are missing parts, we will guarantee complete satisfaction through direct assistance from our factory.

**TO AVOID UNNECESSARY DELAYS, PLEASE CALL DIRECT TO OUR TOLL-FREE CUSTOMER HOT LINE.** The trained technicians on our customer hot line will provide immediate assistance, free of charge to you.

**CUSTOMER HOT LINE:**

**1-800-999-3756**

Mon.–Fri., 6 a.m.–6 p.m. MST

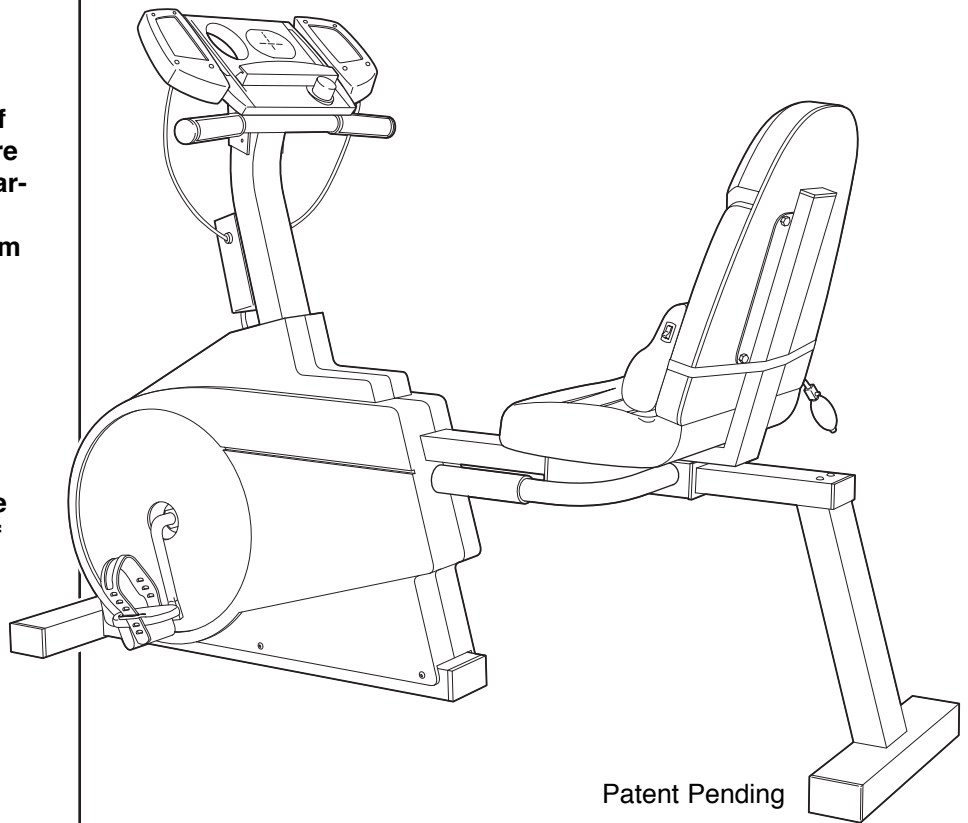

### CAUTION

Read all precautions and instructions in this manual before using this equipment. Keep this manual for future reference.



Visit our website at

[www.proform.com](http://www.proform.com)

new products, prizes,  
fitness tips, and much more!

# TABLE OF CONTENTS

CAUTION DECAL PLACEMENT .....	.2
IMPORTANT PRECAUTIONS .....	.3
BEFORE YOU BEGIN .....	.4
ASSEMBLY .....	.5
EXPLODED DRAWING .....	.10
PART LIST .....	.12
HOW TO USE THE LIGHT CYCLE .....	.13
HOW TO USE THE PULSE SENSOR .....	.17
MAINTENANCE AND STORAGE .....	.18
CONDITIONING GUIDELINES .....	.19
ORDERING REPLACEMENT PARTS .....	.Back Cover
LIMITED WARRANTY .....	.Back Cover

## CAUTION DECAL PLACEMENT

The decals shown below have been placed on the Light Cycle. If one of the decals is missing, or if it is not legible, please call our Customer Service Department toll-free at 1-800-999-3756 to order a free replacement decal. Apply the decal in the location shown.

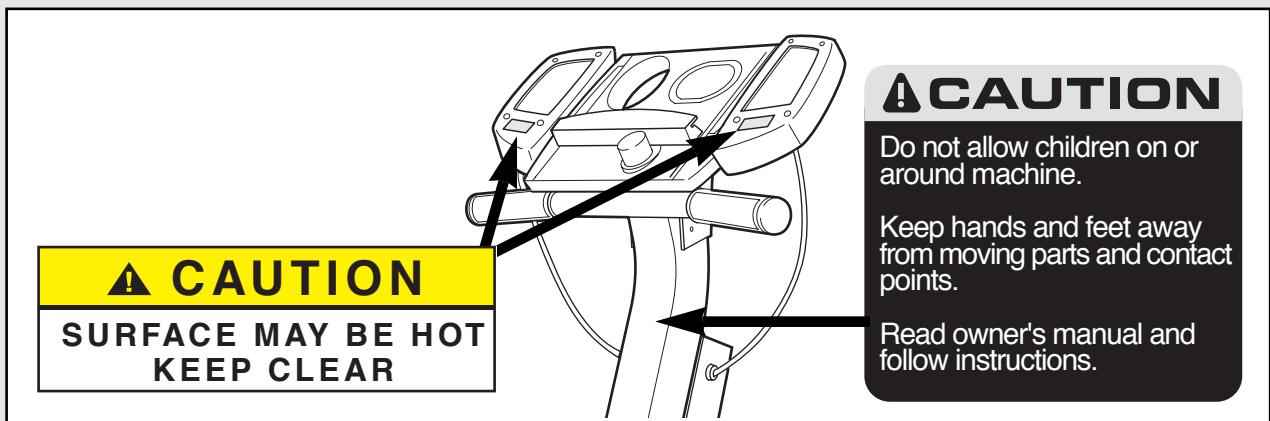

# IMPORTANT PRECAUTIONS

**⚠ WARNING:** To reduce the risk of serious injury, read the following important precautions before using the PROFORM® Light Cycle.

1. Read all instructions in this manual before using the Light Cycle.
2. Use the Light Cycle only as described in this manual.
3. It is the responsibility of the owner to ensure that all users of the Light Cycle are adequately informed of all precautions.
4. The Light Cycle is intended for in-home use only. Do not use the Light Cycle in a commercial, rental, or institutional setting.
5. Use the Light Cycle indoors on a level surface. Keep the Light Cycle away from moisture and dust. Place a mat under the Light Cycle to protect the floor or carpet.
6. Inspect and tighten all parts regularly. Replace any worn parts immediately.
7. Keep children under the age of 12 and pets away from the Light Cycle at all times.
8. The Light Cycle should not be used by persons weighing more than 250 pounds.
9. Wear appropriate clothing when exercising; do not wear loose clothing that could become caught on the Light Cycle. Always wear athletic shoes for foot protection.
10. When connecting the power cord on the light therapy pod (see HOW TO PLUG IN THE POWER CORD on page 16), plug the power cord into a grounded circuit capable of carrying 15 or more amps. No other appliance should be on the same circuit.
11. Keep the power cord away from heated surfaces.
12. If you have serious back injuries or chronic back pain, consult a physician before using the lumbar cushion.
13. Do not use the lumbar cushion if you are pregnant or wearing a pacemaker or any other electrical implant.
14. The magnets in the lumbar cushion are not being sold as medical devices.
15. The light therapy pod becomes hot during use. Allow the light therapy pod to cool before touching it.
16. Do not place towels, clothing, or any other objects on the light therapy pod.
17. Although your eyes must be open to benefit from light therapy, do not look directly into the lights on the light therapy pod.
18. Do not drop or insert any object into any opening.
19. The pulse sensor is not a medical device. Various factors may affect the accuracy of heart rate readings. The pulse sensor is intended only as an exercise aid in determining heart rate trends in general.
20. Always keep your back straight when using the Light Cycle. Do not arch your back.
21. If you feel pain or dizziness at any time while exercising, stop immediately and begin cooling down.
22. **DANGER:** Always unplug the light therapy pod immediately after using it and before cleaning.

**⚠ WARNING:** Before beginning this or any exercise program, consult your physician. This is especially important for persons over the age of 35 or persons with pre-existing health problems. Read all instructions before using. ICON assumes no responsibility for personal injury or property damage sustained by or through the use of this product.

**SAVE THESE INSTRUCTIONS**

# BEFORE YOU BEGIN

Congratulations for selecting the innovative PROFORM® Light Cycle. The PROFORM Light Cycle features a semi-recumbent exercise cycle, a lumbar support with massage and magnet therapy, and a light therapy pod to let you enjoy a variety of exercise and relaxation options in the convenience of your home.

**For your benefit, read this manual carefully before you use the PROFORM Light Cycle.** If you have additional questions, please call our Customer Service Department toll-free at 1-800-999-3756, Monday

through Friday, 6 a.m. until 6 p.m. Mountain Time (excluding holidays). To help us assist you, please mention the product model number and serial number when calling. The model number is PFRX35390. The serial number can be found on a decal attached to the Light Cycle (see the front cover of this manual for the location of the decal).

Before reading further, please look at the drawing below and familiarize yourself with the parts that are labeled.

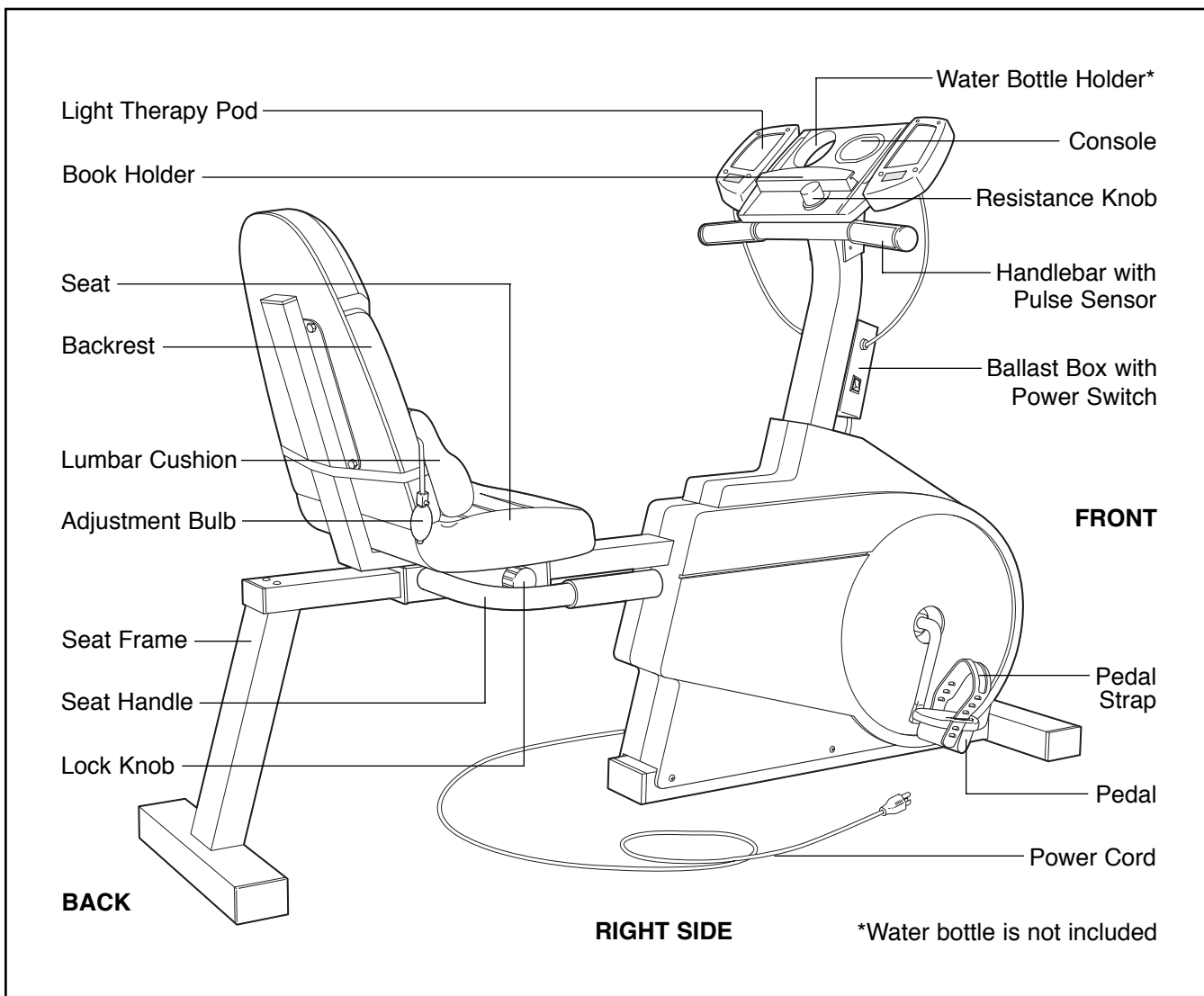

# ASSEMBLY

Place all parts of the Light Cycle in a cleared area and remove the packing materials. **Do not dispose of the packing materials until assembly is completed.**

**Assembly requires the included tools and your own adjustable wrench  and phillips screwdriver .**

To identify the small parts used in assembly, refer to the part drawings below. The number in parenthesis below each drawing refers to the key number of the part, from the part list on page 12. The second number refers to the quantity used in assembly. **Note: Some small parts may have been pre-attached for shipping. If a part is not in the parts bag, check to see if it has been pre-assembled.**



M6 Split Washer (67)–4

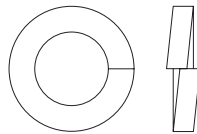

M10 Split Washer (26)–3

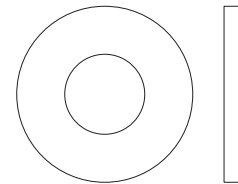

M10 Flat Washer (71)–4

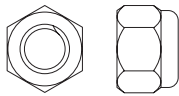

M6 Nylon Locknut (66)–4

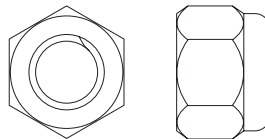

M10 Nylon Locknut (72)–4



M4 x 16mm Screw (34)–1



#8 x 5/8" Screw (22)–4

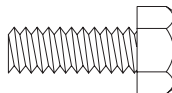

M6 x 16mm Hex Head Screw (24)–8

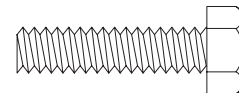

M6 x 25mm Hex Head Screw (14)–4

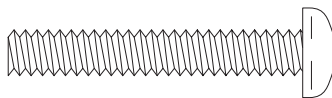

M6 x 38mm Button Head Bolt (18)–4

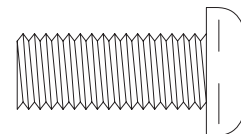

M10 x 25mm Button Head Screw (25)–3

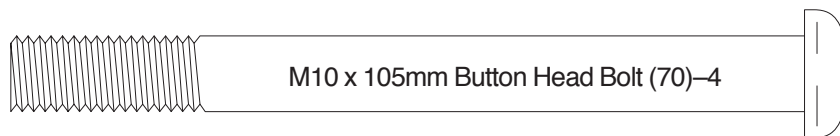

M10 x 105mm Button Head Bolt (70)–4

1. Loosen the Lock Knob (68) on the right side of the Frame (1). Slide the Seat Frame (3) out until it stops. Tighten the Lock Knob.

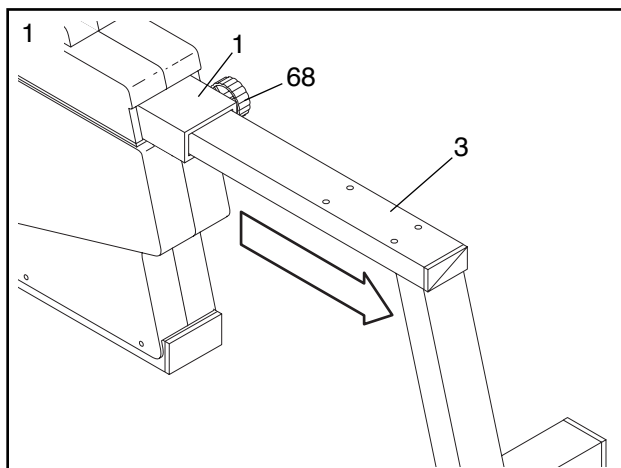

2. Attach the Upright (2) to the Frame (1) with three M10 x 25mm Button Head Screws (25) and three M10 Split Washers (26). **Be careful not to pinch the Reed Switch Wire (13) or the Resistance Cable (10).**

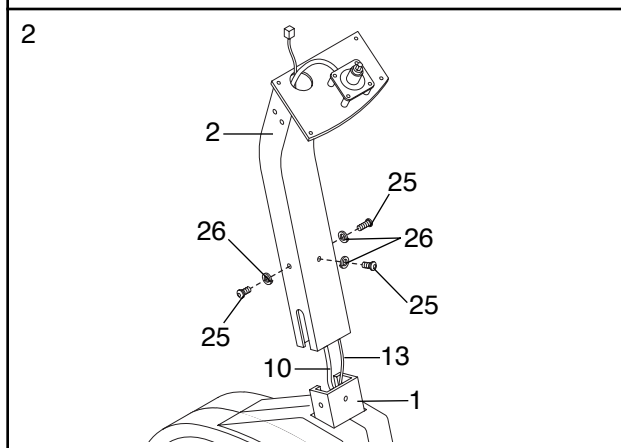

3. The light therapy pod requires two GX 24 Q-3 Base Light Tubes (88). Remove the four #8 x 3/8" Screws (97) from the back of the Left Light Cover (91). Remove the Left Light Cover. Insert a Light Tube into the Light Fixture (87). Reattach the Left Light Cover with the #8 x 3/8" screws.

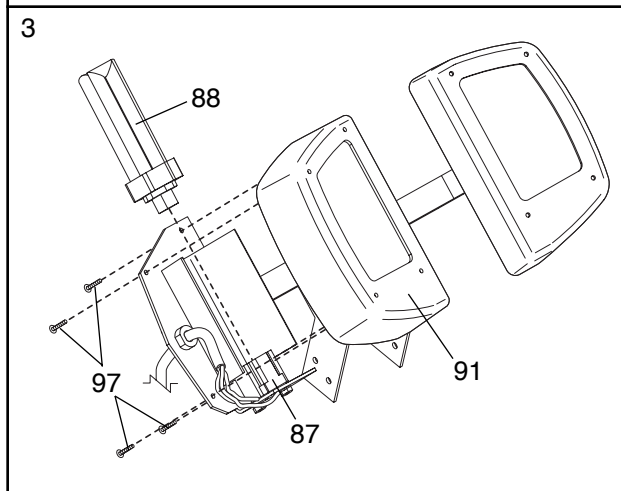

Install a Light Tube (88) into the right side of the light therapy pod in the same manner.

4. Route both Extension Wires (41) up through the Upright (2) as shown.

Attach the Handlebar (4) and the Light Frame (82) to the Upright (2) with two M6 x 25mm Hex Head Screws (14) and two M6 Split Washers (67), **but do not tighten the Screws yet. Make sure that the Screws are in the indicated holes. Note: Two more Screws will be attached in step 6.**

Remove the backing from the Fastener Strip (77) and press it onto the Upright (2) in the position shown. Firmly press the Ballast Box (81) onto the Fastener Strip.

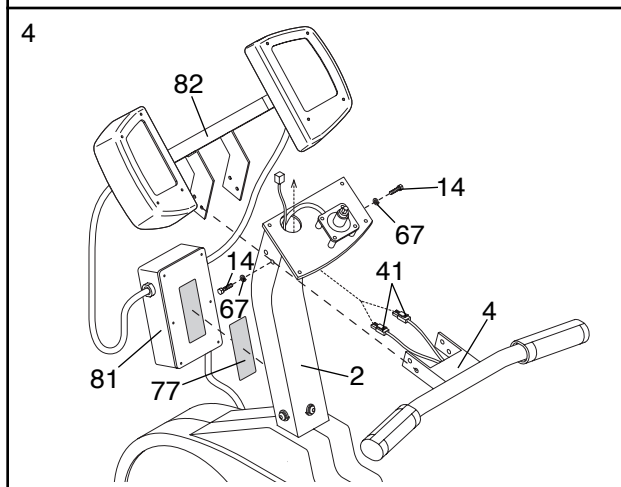

5. Connect the Reed Switch Wire (13) and the two Extension Wires (41) to the corresponding wires on the Console (8).

If your Console (8) has a ground wire, attach it to the Upright (2) with an M4 x 16mm Screw (34).

Next, attach the Console (8) to the Upright (2) with four #8 x 5/8" Screws (22).

Press the Resistance Knob (9) onto the Resistance Control (10). Be sure that the mark on the Knob is correctly aligned.

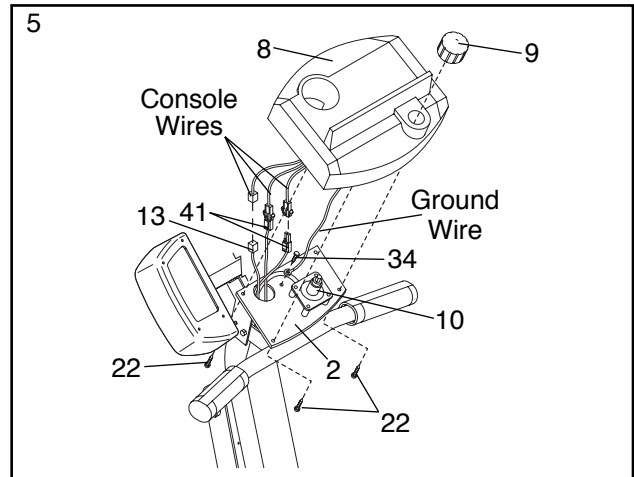

6. Finish attaching the Handlebar (4) and the Light Frame (82) to the Upright (2) with two more M6 x 25mm Hex Head Screws (14) and two more M6 Split Washers (67). **Tighten all four Hex Head Screws.**

Remove the backing from the Cord Clips (95) and press them onto the exercise cycle in the indicated locations. Insert the Power Cord (73) into the Cord Clips. **Make sure that the Power Cord cannot get caught on the pedals while you are exercising.**

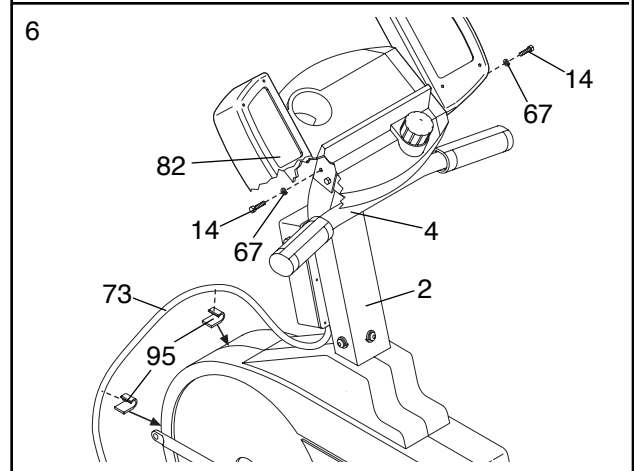

7. Attach the Seat Bracket (69) to the Seat Frame (3) with four M10 x 105mm Button Head Bolts (70), four M10 Flat Washers (71), and four M10 Nylon Locknuts (72).

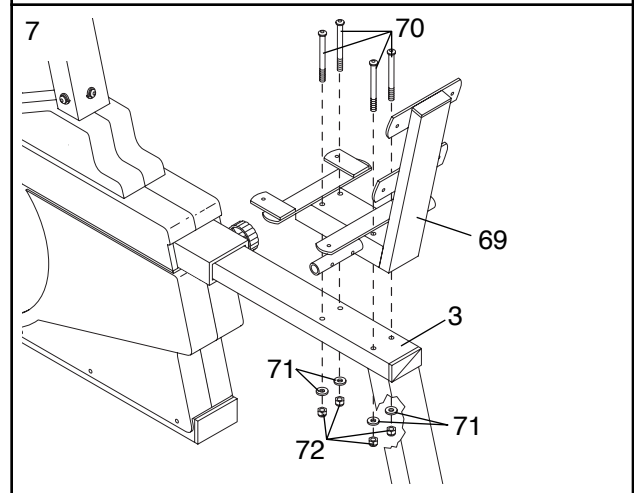

8. Attach the Seat (16) to the Seat Bracket (69) with four M6 x 16mm Hex Head Screws (24).

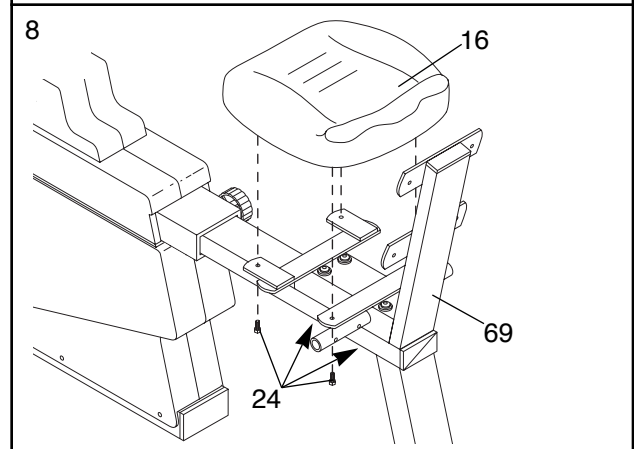

9. Attach a Seat Handle (17) to the Seat Bracket (69) with two M6 x 38mm Button Head Bolts (18) and two M6 Nylon Locknuts (66).

Attach the other Seat Handle (17) to the Seat Bracket (69) in the same manner.

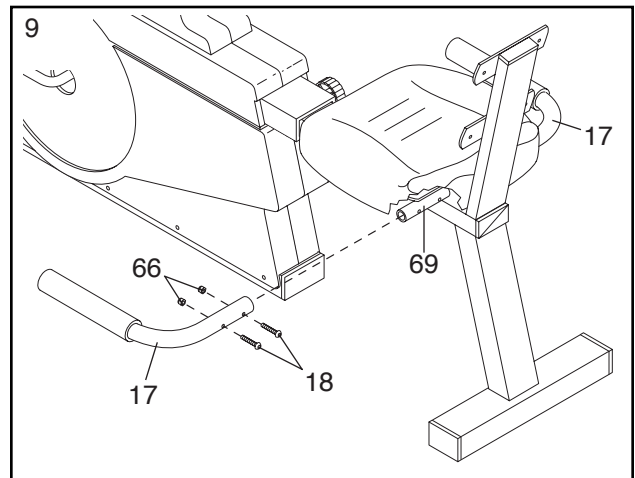

10. Attach the Backrest (15) to the Seat Bracket (69) with four M6 x 16mm Hex Head Screws (24).

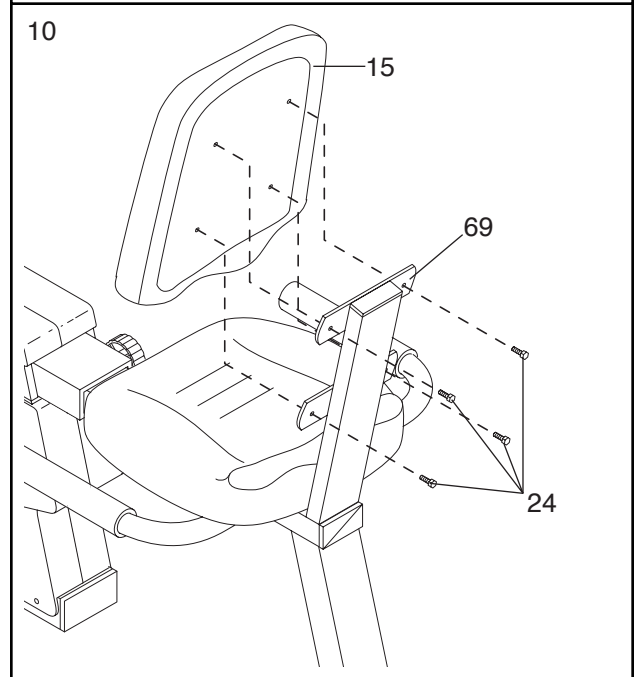

11. Identify the Left Pedal (45) (there is an “L” on the Left Pedal for identification). Using an adjustable wrench, **firmly tighten** the Left Pedal counterclockwise into the left arm of the Crank (29).

**Firmly tighten** the Right Pedal (not shown) clockwise into the right arm of the Crank (29).

Adjust the Pedal Strap (27) on the Left Pedal (45) to the desired position. Press the Pedal Strap onto the tab on the Left Pedal.

Adjust the Pedal Strap on the Right Pedal (not shown) in the same manner.

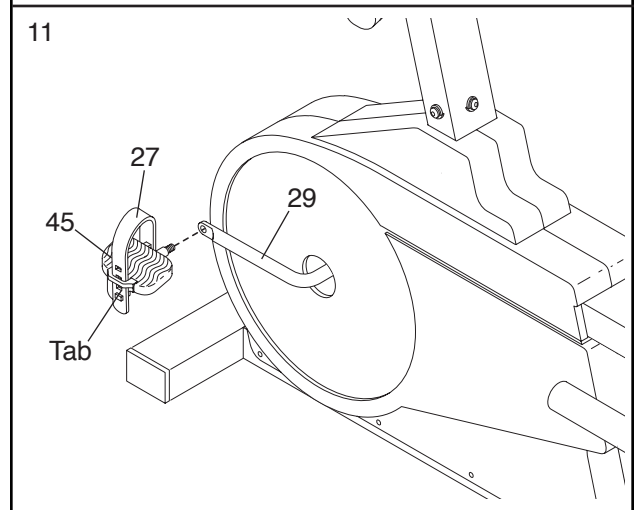



12. The Console (8) requires either two or three “AA” batteries (not included); alkaline batteries are recommended. Open the battery cover (not shown) on the back of the Console. Press the batteries into the battery clip. **Make sure that the negative (–) ends of the batteries are touching the springs.** Close the battery cover. Note: If the battery clip holds three batteries, you must insert three batteries.

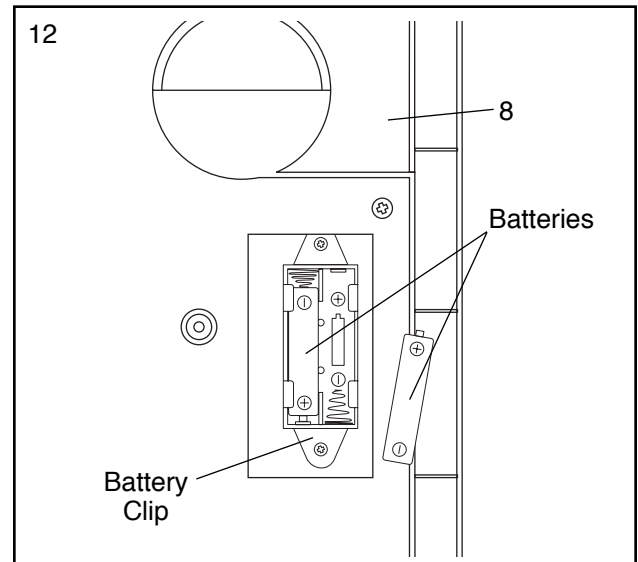

13. The Lumbar Cushion (94) requires two “D” batteries (not included); alkaline batteries are recommended. Open the zipper on the back of the Lumbar Cushion. Press the batteries into the battery clip. **Make sure that the negative (–) ends of the batteries are turned away from the motor.** Close the zipper.

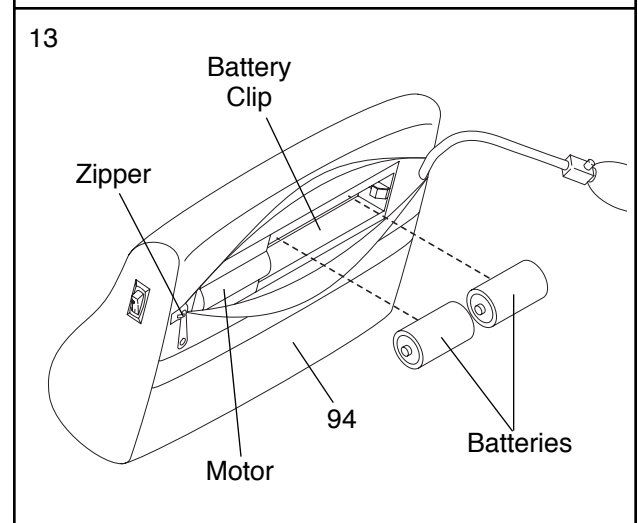

14. Slide the Lumbar Cushion (94) over the Backrest (15) as shown.

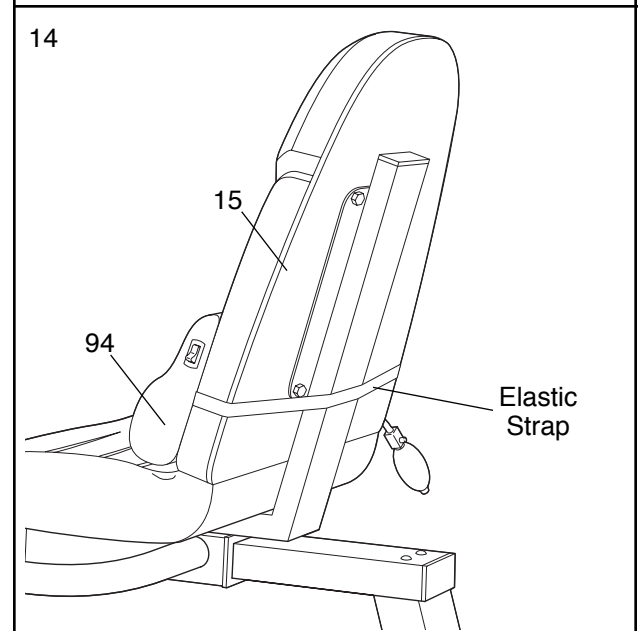

15. **Make sure that all parts are properly tightened before you use the Light Cycle.** Note: Some hardware may be left over after assembly is completed. Place a mat under the Light Cycle to protect the floor or carpet.

# HOW TO USE THE LIGHT CYCLE

## HOW TO ADJUST THE SEAT FRAME

The Seat Frame (3) can be adjusted to the position that is the most comfortable for you. To adjust the Seat Frame, first loosen the Lock Knob (68) on the right side of the Frame (1). Slide the Seat Frame to the desired position and retighten the Lock Knob.

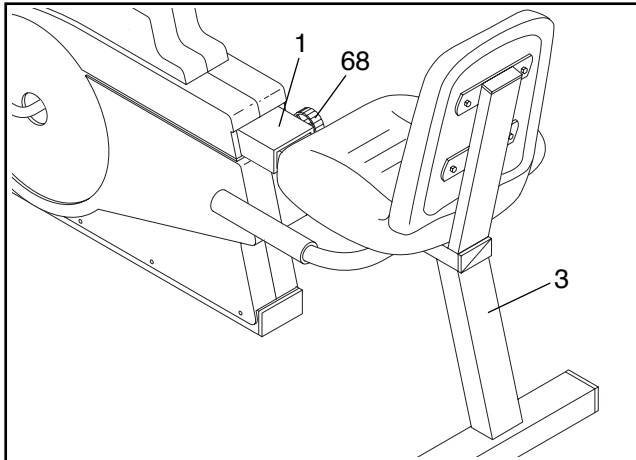

## HOW TO ADJUST THE PEDAL STRAPS

To adjust the Pedal Straps (27, 31 [not shown]), first pull the ends of the Pedal Straps off the tabs on the pedals. Slide the Pedal Straps to the desired positions and press the Pedal Straps back onto the tabs.

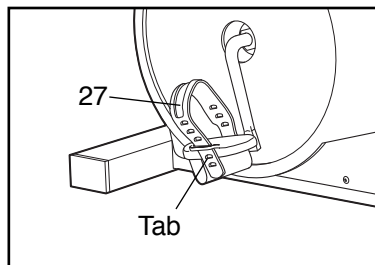

## HOW TO ADJUST THE PEDALING RESISTANCE

The pedaling resistance can be adjusted with the Resistance Knob (9) located on the Console (8). To increase the resistance, turn the Resistance Knob clockwise; to decrease the resistance, turn the Resistance Knob counterclockwise.

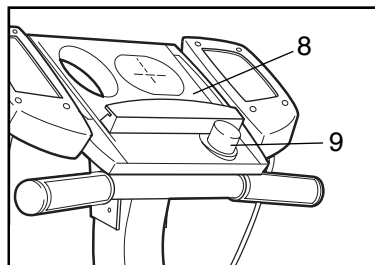

## HOW TO USE THE LUMBAR CUSHION

Slide the Lumbar Cushion (94) over the Backrest (15) as shown. Adjust the position of the Lumbar Cushion until it feels comfortable against your back.

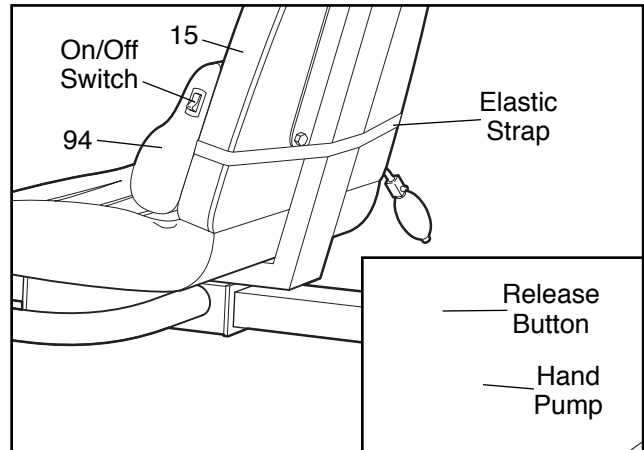

The firmness of the Lumbar Cushion (94) can be adjusted as desired using the attached hand pump. To increase the firmness, squeeze the hand pump repeatedly. To decrease the firmness, press the release button.

The massager in the Lumbar Cushion (94) requires two “D” batteries (not included). If you have not installed batteries, see assembly step 13 on page 9. To turn on the massager, press the top of the on/off switch on the Lumbar Cushion. Press the bottom of the switch to turn off the massager.

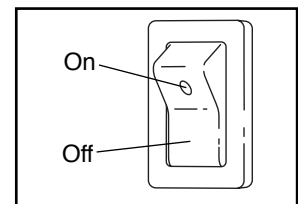

The lumbar cushion also features four 800-gauss magnets for magnet therapy. Research indicates that the positive energy emitted from bipolar magnets may help to increase circulation and eliminate minor aches.

**CAUTION: If you have serious back injuries or chronic back pain, consult a physician before using this product.**

**CAUTION: Do not use this product if you are pregnant or wearing a pacemaker or any other electrical implant. Magnets are not being sold as medical devices.**

## DIAGRAM OF THE CONSOLE

Before the console can be operated, "AA" batteries must be installed. If you have not installed batteries, see assembly step 12 on page 9. Note: If there is a thin sheet of clear plastic on the face of the console, remove the plastic before using the console.

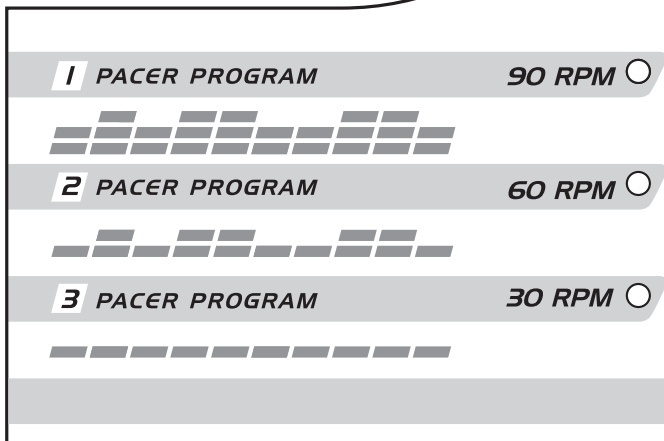
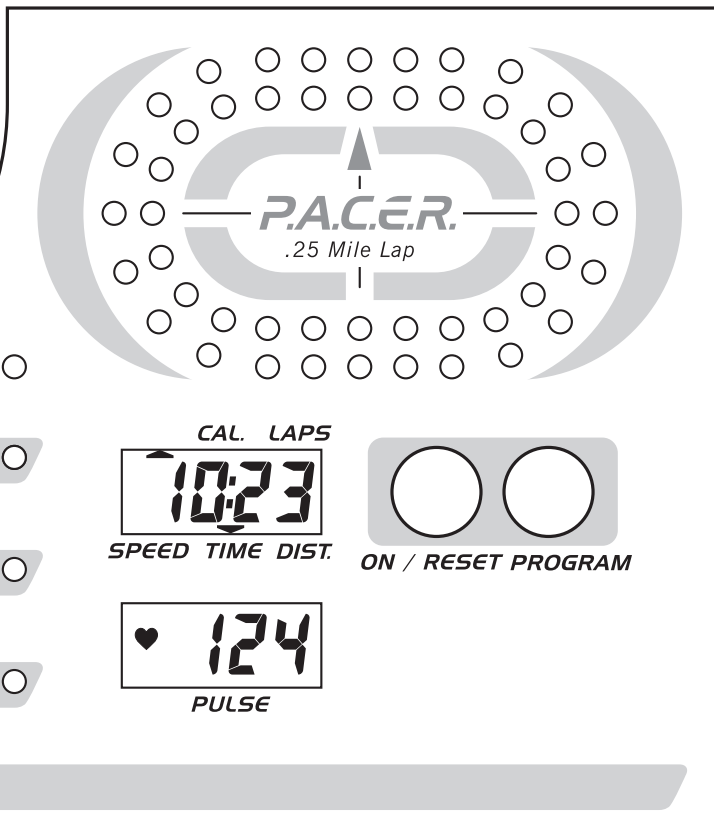

## DESCRIPTION OF THE CONSOLE

The innovative console offers a manual mode and three pacer programs. The pacer programs are designed to help you achieve your exercise goals by pacing your exercise. The programs include an 18 MPH/90 RPM program, a 12 MPH/60 RPM program, and a 6 MPH/30 RPM program. The console also features five monitor modes that provide continuous exercise feedback. **Note: On some consoles the programs are listed in MPH and on others in RPM. Both sets of programs are identical.**

## HOW THE PACER PROGRAMS OPERATE

When you use a pacer program, an indicator will light on each track of the P.A.C.E.R. display. The outer track shows a target pace; the inner track will show your actual pace. The target pace will change periodically during the 18 MPH/90 RPM and 12 MPH/60 RPM programs; as the target pace changes, simply adjust your pace to keep both indicators even. **Important: The target pace is a goal pace. Your actual pace may be slower than the tar-**

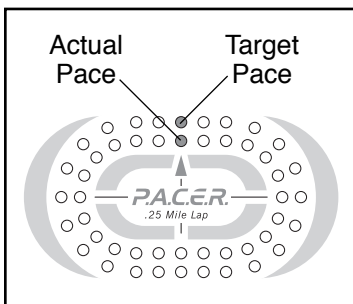

**get pace, especially during the first few months of your exercise program. Be sure to exercise at a pace that is comfortable for you.**

The graphs on the left side of the console show how the target pace will change during each program (see the drawing above). Each graph is divided into ten columns, and each column represents 1/10 of a mile. The bars in each column show what the target pace will be during that 1/10 of a mile. For example, in the first column of the 12 MPH/60 RPM graph, there is one bar. This shows that during the first 1/10 of a mile in this program, the target pace will be 6 MPH (30 RPM). In the second column, there are two bars, indicating that the pace is now 12 MPH (60 RPM).

## DESCRIPTION OF THE MONITOR MODES

The five monitor modes provide continuous exercise feedback. The modes are described below.

- **Speed**—This mode shows your pace, in miles per hour.
- **Time**—This mode counts the length of time you have exercised. Note: If you stop exercising for ten seconds or longer, the time mode will pause.
- **Distance (DIST)**—This mode shows the total number of miles you have cycled, up to 999. The display will then reset to zero and continue counting.

- Laps—This mode shows the number of quarter-mile laps you have completed.
- Calories (CAL)—This mode shows the approximate number of calories you have burned.

### STEP-BY-STEP CONSOLE OPERATION

Follow the steps below to operate the console.

#### 1 Turn on the power

To turn on the power, press the on/reset button or simply begin exercising. When the power is turned on, the entire display will appear for two seconds. The console will then be ready for use. Note: If batteries were just installed, the power will already be on.

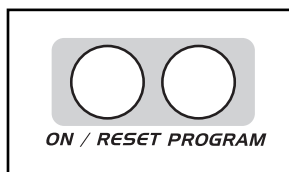

#### 2 Select one of the three pacer programs or the manual mode

When the power is first turned on, the console will be in the manual mode. To select one of the pacer programs, repeatedly press the program button. The program indicator will show which program you have selected. The programs will be selected in the following order: the manual mode, the 6 MPH/30 RPM program, the 12 MPH/60 RPM program, and the 18 MPH/90 RPM program. Note: Once you select a pacer program, you can reselect the manual mode by repeatedly pressing the program button.

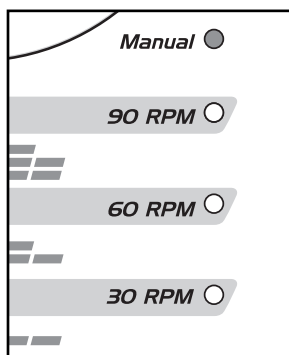

#### 3 Begin your workout

If you selected the manual mode, one indicator on the inner P.A.C.E.R. track will light. As you exercise, this indicator will move around the quarter-mile track.

If you selected a pacer program, two indicators on the P.A.C.E.R. track will light. The indicator on the inner track will show your actual pace. The indicator on the outer track will move around the track at the programmed pace. As you exercise, adjust your pace so that the indicators on the inner and outer tracks remain even. As the program progresses, the target pace will change periodically; as the target pace changes, you should also adjust your pace. **Important: The target pace is a goal pace. Your actual pace may be slower than the target pace, especially during the first few months of your exercise program. Be sure to exercise at a pace that is comfortable for you.**

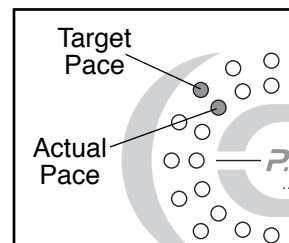

#### 4 Follow your progress with the monitor modes

When the power is turned on, the console will scan through the five modes automatically. A flashing mode indicator will show which mode is currently displayed.

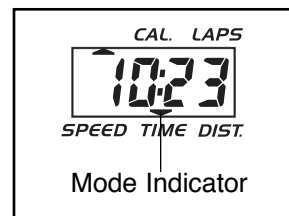

When the Laps mode is displayed, an "L" will also appear. If desired, the display can be reset by pressing the on/reset button.

The Light Cycle also features an innovative handgrip pulse sensor. The pulse display allows you to monitor your heart rate during your workout. To use the pulse sensor, see page 17.

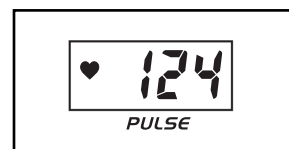

#### 5 Turn off the power

To turn off the power, simply wait for about six minutes. If the pedals are not moved and the console buttons are not pressed for six minutes, the power will turn off automatically.

## HOW TO PLUG IN THE POWER CORD ON THE LIGHT THERAPY POD

**⚠ DANGER:** Improper connection of the equipment-grounding conductor can result in an increased risk of electric shock. Check with a qualified electrician or service representative if you are in doubt as to whether the product is properly grounded. Do not modify the plug provided with the product—if it will not fit the outlet, have a proper outlet installed by a qualified electrician.

**This product must be grounded.** If it should malfunction or break down, grounding provides a path of least resistance for electric current to reduce the risk of electric shock. This product is equipped with a cord having an equipment-grounding conductor and a grounding plug. **Plug the power cord into an appropriate outlet that is properly installed and grounded in accordance with all local codes and ordinances.**

This product is for use on a nominal 120-volt circuit, and has a grounding plug that looks like the plug illustrated in drawing 1 below. A temporary adapter that looks like the adapter illustrated in drawing 2 may be used to connect the power cord to a 2-pole receptacle as shown in drawing 2 if a properly grounded outlet is not available.

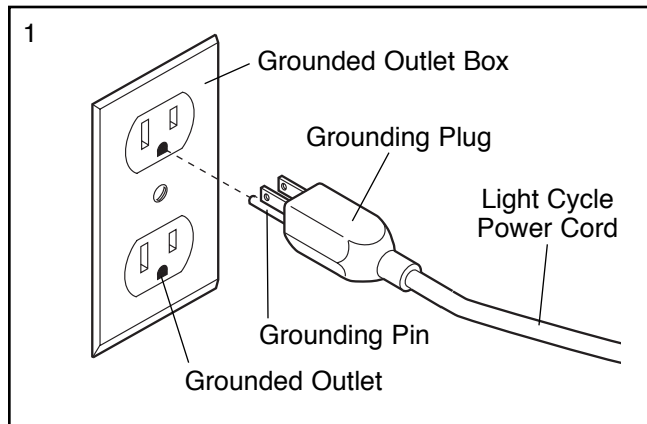

The temporary adapter should be used only until a properly grounded outlet (drawing 1) can be installed by a qualified electrician.

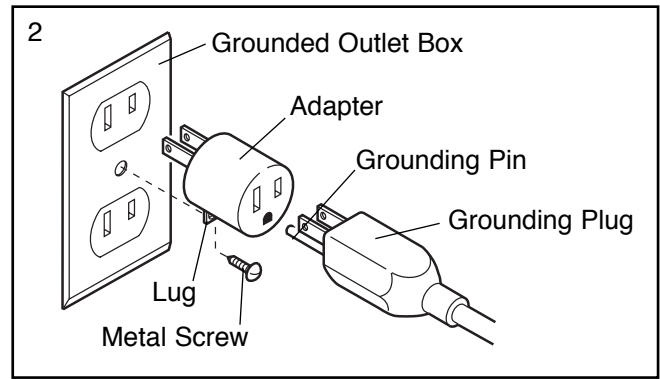

The green-colored rigid ear, lug, or the like extending from the adapter must be connected to a permanent ground such as a properly grounded outlet box cover. Whenever the adapter is used it must be held in place by a metal screw. **Some 2-pole receptacle outlet box covers are not grounded. Contact a qualified electrician to determine if the outlet box cover is grounded before using an adapter.**

## HOW TO USE THE LIGHT THERAPY POD

The light therapy pod allows you to enjoy the benefits of light therapy while you exercise or while you simply relax.

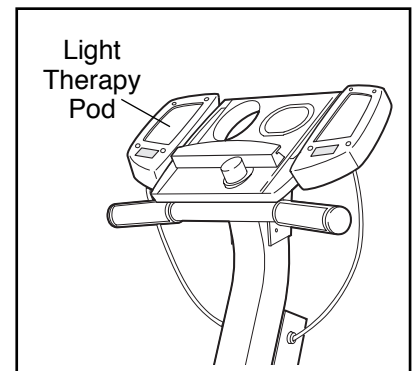

The effectiveness of light therapy depends on two factors: your distance from the light and the length of time you use the light. The chart below shows the intensity of the lights at different distances.

Distance	6"	12"	18"	24"
Lux	10,000	3,200	2,500	1,500

**WARNING:** Before beginning this or any light therapy program, consult your physician.

**WARNING:** The light therapy pod becomes hot during use. Allow the light therapy pod to cool before touching it.

Follow the steps below to use the light therapy pod.

1. Plug in the power cord (see page 16).
2. Sit on the Light Cycle and adjust the position of the seat as desired.
3. Press the bottom of the on/off switch on the ballast box to turn on the lights.

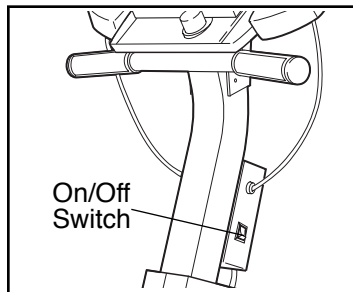

4. To enjoy the benefits of light therapy, it is not necessary to look at the lights. However, you must open your eyes so that light can enter.

It is recommended that you use the lights for 30 to 60 minutes three times per week to begin with. This may be done while exercising or while relaxing. When you are familiar with the light therapy pod, you may adjust the length and frequency of your light therapy sessions as desired.

5. When you are finished using the light therapy pod, press the top of the on/off switch on the ballast box to turn off the lights. In addition, **unplug the power cord**.

---

## HOW TO USE THE PULSE SENSOR

The convenient pulse sensor allows you to measure your heart rate periodically. You can measure your heart rate before you begin exercising, during your workout, and again when you finish.

**Note: Before the pulse sensor can be used, the protective vinyl covering must be peeled off the metal contacts on the front and rear of each pulse grip.**

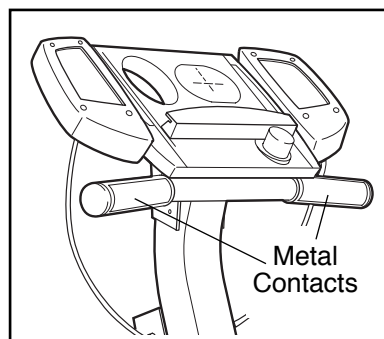

To use the pulse sensor, first make sure that the power is turned on. Stop exercising, rest both feet on the floor, and place your hands on the metal contacts. Your palms must be resting on the inner contacts and your fingers must be touching the outer contacts. Avoid moving your hands. After a moment, the heart indicator in the PULSE display will flash and your heart rate will be shown. For the most accurate heart rate reading, continue to hold the contacts for about 15 seconds.

**WARNING: The pulse sensor is not a medical device. Various factors, including the user's movement, may affect the accuracy of heart rate readings. The pulse sensor is intended only as an exercise aid in determining heart rate trends in general.**

### HAND PULSE SENSOR TROUBLE-SHOOTING

- Avoid moving your hands while using the pulse sensor. Excessive movement may interfere with heart rate readings. If the pulse sensor is not used correctly, the heart indicator will flash repeatedly in the PULSE display but your heart rate will not be shown.
- Do not hold the metal contacts too tightly; doing so may interfere with heart rate readings.
- Do not move your hands while you hold the metal contacts; your muscle movement may interfere with heart rate readings.
- For the most accurate heart rate reading, wait for about 15 seconds.
- For optimal performance of the pulse sensor, keep the metal contacts clean. The contacts can be cleaned with a soft cloth—never use alcohol, abrasives, or chemicals.

# MAINTENANCE AND STORAGE

Inspect and tighten all parts of the Light Cycle regularly. The Light Cycle can be cleaned with a soft, damp cloth. To prevent damage to the console, keep liquids away and keep the console out of direct sunlight.

## BATTERY REPLACEMENT

If the console does not function properly, the batteries should be replaced. To replace the batteries, refer to assembly step 12 on page 9.

## CRANK ADJUSTMENT

If the arms of the Crank (29) become loose, they should be tightened in order to prevent excessive wear. Loosen the Crank Nut (35) on the left arm of the Crank. Place the end of a standard screw-

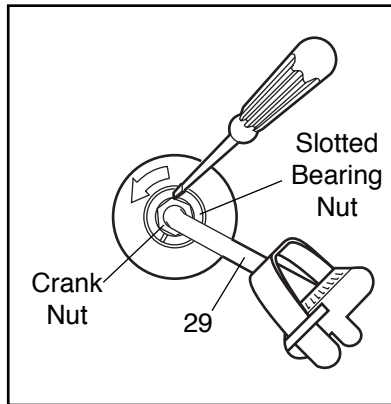

driver in one of the slots in the slotted bearing nut. Lightly tap the screwdriver with a hammer to turn the slotted bearing nut counterclockwise until the arms are no longer loose. **Do not overtighten the slotted bearing nut.** When the slotted bearing nut is properly tightened, tighten the Crank Nut.

## HOW TO STORE THE EXERCISE CYCLE

When the exercise cycle is not in use, it can be folded for compact storage. Refer to the drawing at the right. Loosen the Lock Knob (68) on the right side of the Frame (1). Slide the Seat Frame (3) as far into the Frame as it will go. Tighten the Lock Knob. Store the exercise cycle indoors, away from moisture and dust.

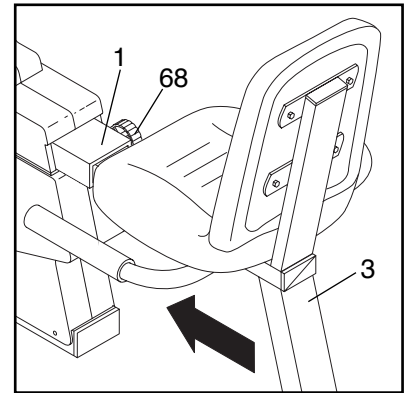

# CONDITIONING GUIDELINES

The following guidelines will help you to plan your exercise program. Remember that proper nutrition and adequate rest are essential for successful results.

**WARNING: Before beginning this or any exercise program, consult your physician. This is especially important for individuals over the age of 35 or individuals with pre-existing health problems.**

## WHY EXERCISE?

Exercise has proven essential for good health and general well-being. Regular participation in a well-rounded exercise program results in a stronger and more efficient heart, improved respiratory function, increased stamina and endurance, better weight management and body fat control, increased ability to deal with stress, and greater self-esteem and confidence.

## EXERCISE INTENSITY

To maximize the benefits of exercising, it is important to exercise with the proper intensity. The proper intensity level can be found by using your heart rate as a guide. For effective aerobic exercise, your heart rate should be maintained at a level between 70% and 85% of your maximum heart rate as you exercise. This is known as your training zone. You can find

AGE	TRAINING ZONE (BEATS/MIN.)	
	UNCONDITIONED	CONDITIONED
20	138–167	133–162
25	136–166	132–160
30	135–164	130–158
35	134–162	129–156
40	132–161	127–155
45	131–159	125–153
50	129–156	124–150
55	127–155	122–149
60	126–153	121–147
65	125–151	119–145
70	123–150	118–144
75	122–147	117–142
80	120–146	115–140
85	118–144	114–139

your training zone in the table below. Training zones are listed according to age and physical condition. During the first few months of your exercise program, keep your heart rate near the low end of your training zone as you exercise. After a few months of regular exercise, your heart rate can be increased gradually until it is near the middle of your training zone as you exercise.

To measure your heart rate, use the pulse sensor in the handlebar. You can also measure your pulse by placing two fingers

on your wrist. Stop exercising and take a six-second heartbeat count. Multiply the result by ten to find your heart rate. (A six-second count is used because your heart rate

drops quickly when you stop exercising.) If your heart rate is too high, decrease the intensity of your exercise. If your heart rate is too low, increase the intensity of your exercise.

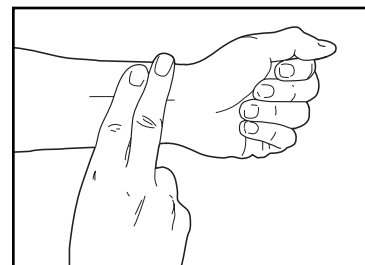

## WORKOUT GUIDELINES

A well-rounded workout includes the following three phases:

**A warm-up phase**, lasting 5 to 10 minutes. Begin with slow, controlled stretches, and progress to more rhythmic stretches. This will increase the body temperature, heart rate, and circulation in preparation for strenuous exercise.

**A cardiovascular phase**, including 20 to 30 minutes of exercising with your heart rate in your training zone.

**A cool-down phase**, consisting of 5 to 10 minutes of stretching. Thorough stretching offsets muscle contractions and other problems caused when you stop exercising suddenly. Stretching for increased flexibility is often most effective during this phase. This phase should leave you relaxed and comfortably tired.

To maintain or improve your condition, complete three workouts each week, with at least one day of rest between workouts. After a few months of regular exercise, you may complete up to five workouts each week, if desired. Find the best time of day for your workouts, and then stick with it. Remember, the key to success is to make exercise a regular and enjoyable part of your everyday life.



---

# ORDERING REPLACEMENT PARTS

To order replacement parts, call our Customer Service Department toll-free at 1-800-999-3756, Monday through Friday, 6 a.m. until 6 p.m. Mountain Time (excluding holidays). To help us assist you, please be prepared to give the following information:

- The MODEL NUMBER of the product (PFRX35390)
- The NAME of the product (PROFORM® Light Cycle)
- The SERIAL NUMBER of the product (see the front cover of this manual)
- The KEY NUMBER and DESCRIPTION of the part(s) (see the EXPLODED DRAWING and PART LIST attached in the center of this manual).

PROFORM® is a registered trademark of ICON Health & Fitness, Inc.

## LIMITED WARRANTY

ICON Health & Fitness, Inc. (ICON), warrants this product to be free from defects in workmanship and material, under normal use and service conditions, for a period of ninety (90) days from the date of purchase. This warranty extends only to the original purchaser. ICON's obligation under this warranty is limited to replacing or repairing, at ICON's option, the product through one of its authorized service centers. All repairs for which warranty claims are made must be pre-authorized by ICON. This warranty does not extend to any product or damage to a product caused by or attributable to freight damage, abuse, misuse, improper or abnormal usage or repairs not provided by an ICON authorized service center, products used for commercial or rental purposes, or products used as store display models. No other warranty beyond that specifically set forth above is authorized by ICON.

ICON is not responsible or liable for indirect, special or consequential damages arising out of or in connection with the use or performance of the product or damages with respect to any economic loss, loss of property, loss of revenues or profits, loss of enjoyment or use, costs of removal, installation or other consequential damages of whatsoever nature. Some states do not allow the exclusion or limitation of incidental or consequential damages. Accordingly, the above limitation may not apply to you.

The warranty extended hereunder is in lieu of any and all other warranties and any implied warranties of merchantability or fitness for a particular purpose is limited in its scope and duration to the terms set forth herein. Some states do not allow limitations on how long an implied warranty lasts. Accordingly, the above limitation may not apply to you.

This warranty gives you specific legal rights. You may also have other rights which vary from state to state.

**ICON HEALTH & FITNESS, INC., 1500 S. 1000 W., LOGAN, UT 84321-9813**

# PART LIST—Model No. PFRX35390

R1099A

Key No.	Qty.	Description	Key No.	Qty.	Description
1	1	Frame	51	1	M6 x 56mm Bolt
2	1	Upright	52	2	M8 Split Washer
3	1	Seat Frame	53	4	#8 Flat Washer
4	1	Handlebar	54	1	Clamp Bolt
5	2	Pulse Grip	55	1	Clamp Nut
6	1	Left Side Shield	56	1	Resistance Hook
7	1	Right Side Shield	57	1	Resistance Spring
8	1	Console	58	1	Magnet Bracket
9	1	Resistance Knob	59	1	M8 x 65mm Hex Head Bolt
10	1	Resistance Cable/Control	60	1	M8 Nylon Locknut
11	4	M5 x 30mm Screw	61	1	Drive Belt
12	4	M5 Nut	62	2	1 1/4" Round Endcap
13	1	Reed Switch/Wire	63	1	2" x 4" Endcap
14	4	M6 x 25mm Hex Head Screw	64	1	Frame Bushing
15	1	Backrest	65	1	Seat Frame Bushing
16	1	Seat	66	4	M6 Nylon Locknut
17	2	Seat Handle	67	4	M6 Split Washer
18	4	M6 x 38mm Button Head Bolt	68	1	Lock Knob
19	2	Foam Handle Grip	69	1	Seat Bracket
20	1	1" x 3" Endcap	70	4	M10 x 105mm Button Head Bolt
21	6	Tree Fastener	71	4	M10 Flat Washer
22	21	#8 x 5/8" Screw	72	4	M10 Nylon Locknut
23	2	#8 x 3/8" Screw	73	1	Power Cord
24	8	M6 x 16mm Hex Head Screw	74	5	Grommet
25	3	M10 x 25mm Button Head Screw	75	1	Power Switch
26	3	M10 Split Washer	76	2	Fixture Cord
27	1	Left Pedal Strap	77	1	Fastener Strip
28	1	Right Pedal	78	6	Cover Screw
29	1	Crank/Pulley	79	2	Ballast Screw
30	1	Bearing Assembly	80	1	Ballast
31	1	Right Pedal Strap	81	1	Ballast Box
32	1	Magnet	82	1	Light Frame
33	2	M4 x32mm Screw	83	8	Light Cover Screw
34	1	M4 x 16mm Screw	84	1	Ballast Cover
35	4	Rubber Bumper	85	8	Fixture Nut
36	2	M8 Flanged Hex Nut	86	8	Fixture Screw
37	2	M6 Eyebolt	87	2	Light Fixture
38	2	Adjustment Bracket	88	2	Light Tube
39	4	M6 Nut	89	2	Lens
40	2	M10 Washer	90	8	Hex Spacer
41	2	Extension Wire	91	1	Left Light Cover
42	1	Flywheel	92	1	Right Light Cover
43	1	10mm x 13mm Spacer	93	1	Junction Wire
44	1	Flywheel Axle	94	1	Lumbar Cushion
45	1	Left Pedal	95	2	Cord Clip
46	2	M10 x 52mm Button Head Screw	96	1	Support Bladder
47	2	Wheel	97	8	#8 x 3/8" Screw
48	5	2" x 3" Endcap	#	1	User's Manual
49	1	1 1/2" x 3" Endcap	#	1	4mm Allen Wrench
50	1	Cable Clamp	#	1	5.5mm Allen Wrench

Note: “#” indicates a non-illustrated part. Specifications are subject to change without notice. See the back cover of this manual for information about ordering replacement parts.

## Free Manuals Download Website

<http://myh66.com>

<http://usermanuals.us>

<http://www.somanuals.com>

<http://www.4manuals.cc>

<http://www.manual-lib.com>

<http://www.404manual.com>

<http://www.luxmanual.com>

<http://aubethermostatmanual.com>

Golf course search by state

<http://golfingnear.com>

Email search by domain

<http://emailbydomain.com>

Auto manuals search

<http://auto.somanuals.com>

TV manuals search

<http://tv.somanuals.com>