

PRO-FORM[®]

650

Model No. PFSY69520

Serial No. _____

The serial number is found in the location shown below. Write the serial number in the space above.

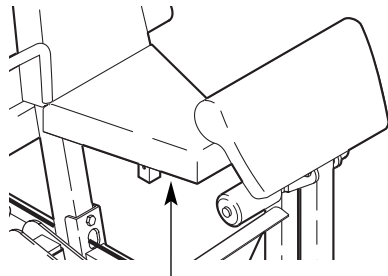

Serial Number Decal

USER'S MANUAL

QUESTIONS?

As a manufacturer, we are committed to providing complete customer satisfaction. If you have questions, or if there are missing parts, we will guarantee complete satisfaction through direct assistance from our factory.

TO AVOID DELAYS, PLEASE CALL DIRECT TO OUR TOLL-FREE CUSTOMER HOT LINE. The trained technicians on our customer hot line will provide immediate assistance, free of charge.

CUSTOMER HOT LINE:

1-800-999-3756

Mon.–Fri., 6 a.m.–6 p.m. MST

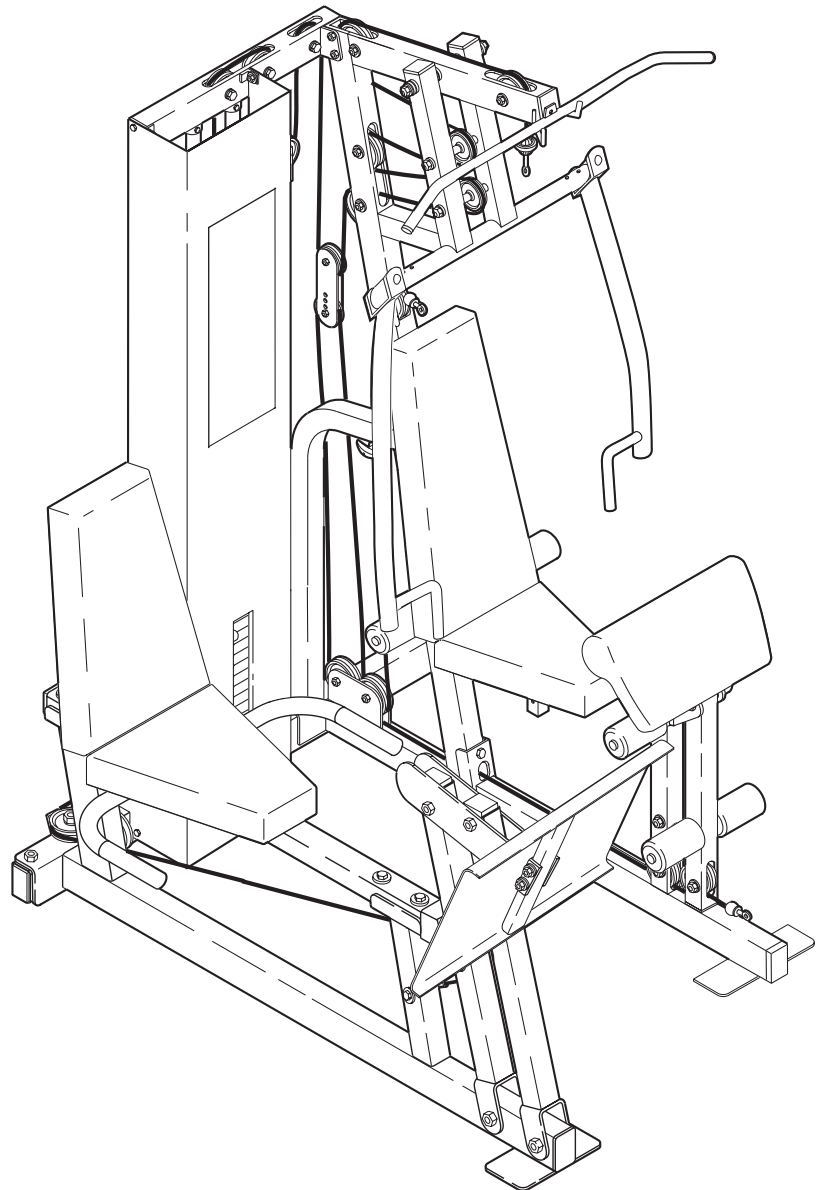

CAUTION

Read all precautions and instructions in this manual before using this equipment. Save this manual for future reference.



Visit our website at

www.proform.com

*new products, prizes,
fitness tips, and much more!*

TABLE OF CONTENTS

IMPORTANT PRECAUTIONS	3
BEFORE YOU BEGIN	4
ASSEMBLY	5
CABLE DIAGRAM	21
ADJUSTMENTS	22
WEIGHT RESISTANCE CHART	24
TROUBLESHOOTING AND MAINTENANCE	25
EXERCISE GUIDELINES	26
ORDERING REPLACEMENT PARTS	Back Cover
LIMITED WARRANTY	Back Cover

Note: A PART IDENTIFICATION CHART and a PART LIST/EXPLODED DRAWING are attached in the center of this manual. Remove the PART IDENTIFICATION CHART and PART LIST/EXPLODED DRAWING before beginning assembly.

IMPORTANT PRECAUTIONS

⚠ WARNING: To reduce the risk of serious injury, read the following important precautions before using the weight system.

1. Read all instructions in this manual and in the accompanying literature before using the weight system. Use the weight system only as described in this manual.
2. It is the responsibility of the owner to ensure that all users of the weight system are adequately informed of all precautions.
3. The weight system is intended for home use only. Do not use the weight system in a commercial, rental, or institutional setting.
4. Use the weight system only on a level surface. Cover the floor or carpet beneath the weight system to protect the floor.
5. Make sure all parts are properly tightened each time you use the weight system. Replace any worn parts immediately.
6. Keep children under the age of 12 and pets away from the weight system at all times.
7. The weight system is designed to be used by only one person at a time. The weight system is designed to support a maximum user weight of 300 pounds.
8. Always wear athletic shoes for foot protection while exercising.
9. *Always disconnect the lat bar from the weight system when performing an exercise that does not require it.*
10. Make sure the cables remain on the pulleys at all times. If the cables bind while you are exercising, stop immediately and make sure the cables are on all of the pulleys.
11. Always stand on the foot plate when performing an exercise that could cause the weight system to tip.
12. Never release the press arm, leg lever, lat bar, leg press, ab strap, or ankle strap while weights are raised. The weights will fall with great force.
13. Keep hands and feet away from moving parts.
14. Insert the weight pin fully into the weight stack before exercising.
15. If you feel pain or dizziness at any time while exercising, stop immediately and cool down.
16. The warning decals shown here have been placed on the weight system in the locations shown on page 4. Note that decals number 2 and 3 have been placed in two locations each. If a decal is missing or illegible, please call our Customer Service Department toll-free at 1-800-999-3756, Monday through Friday, 6 a.m. until 6 p.m. Mountain Time, to order a free replacement decal. Place the decal on the weight system in the location shown on page 4.

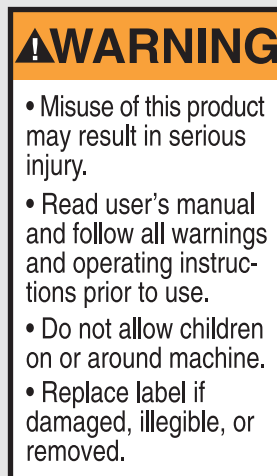

Warning Decal No. 1



Warning Decal No. 2



Warning Decal No. 3

⚠ WARNING: Before beginning this or any exercise program, consult your physician. This is especially important for persons over the age of 35 or persons with pre-existing health problems. Read all instructions before using. ICON assumes no responsibility for personal injury or property damage sustained by or through the use of this product.

BEFORE YOU BEGIN

Thank you for selecting the versatile PROFORM® 650 weight system. The weight system offers a selection of weight stations designed to develop every major muscle group of the body. Whether your goal is to tone your body, build dramatic muscle size and strength, or improve your cardiovascular system, the weight system will help you to achieve the results you want.

toll-free at 1-800-999-3756, Monday through Friday, 6 a.m. until 6 p.m. Mountain Time (excluding holidays). To help us assist you, please note the product model number and serial number before calling. The model number is PFSY69520. The serial number can be found on a decal attached to the weight system (see the front cover of this manual).

For your benefit, read this manual carefully before using the weight system. If you have additional questions, please call our Customer Service Department

Before reading further, please review the drawing below and familiarize yourself with the parts that are labeled.

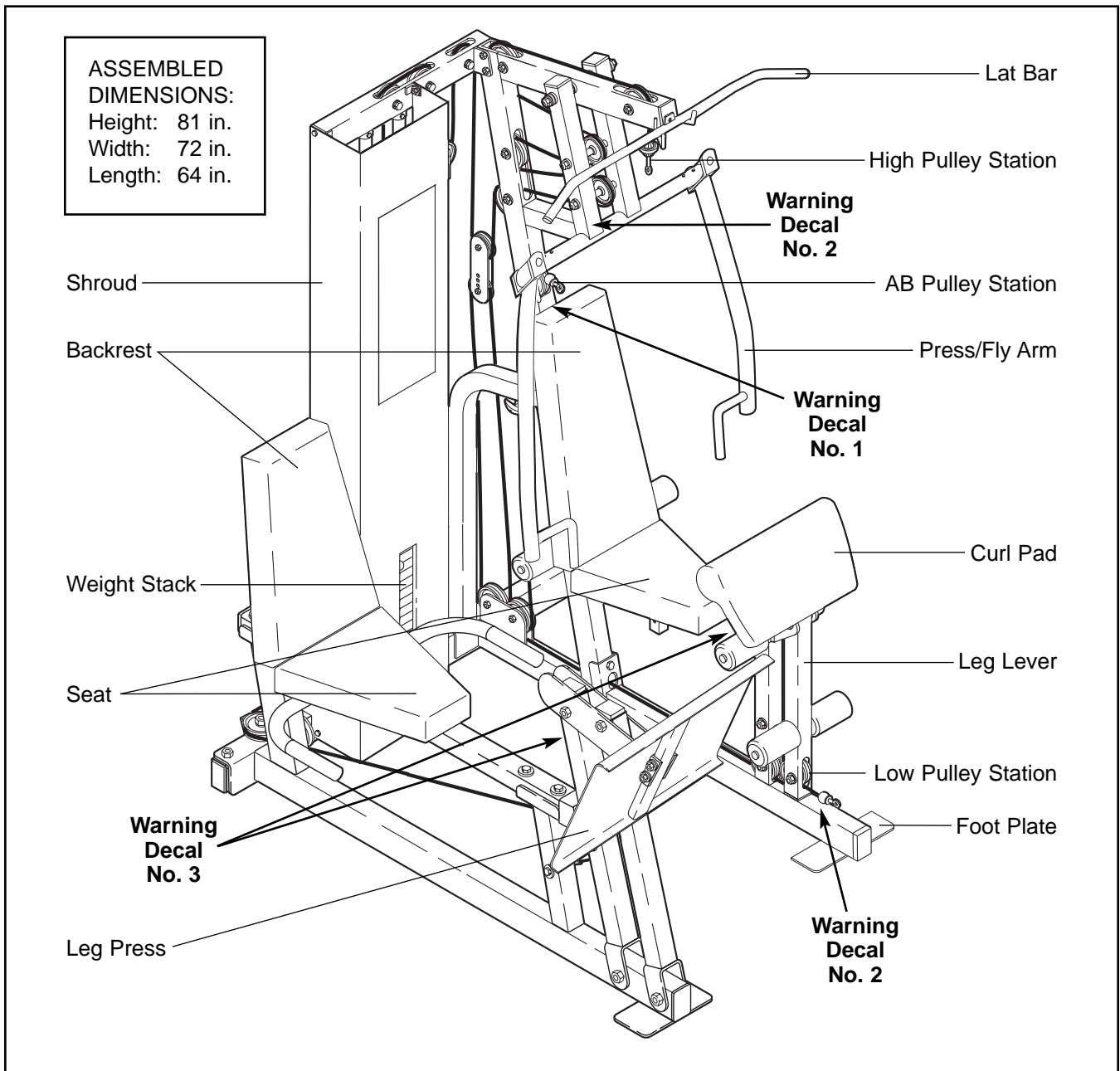

ASSEMBLY

Make Assembly Easier for Yourself

Everything in this manual is designed to ensure that the weight system can be assembled successfully by anyone. **Before beginning assembly, make sure to read the information on this page; this brief introduction will save you much more time than it takes to read it.**

Assembly Requires Two Persons

For your convenience and safety, assemble the weight system with the help of another person.

Set Aside Enough Time

Due to the many features of the weight system, the assembly process will require a few hours. By setting aside plenty of time and by deciding to make the task enjoyable, assembly will go smoothly. You may want to assemble the weight system over a couple of evenings.



Select a Location for the Weight System

Because of its weight and size, the weight system should be assembled in the location where it will be used. Make sure that there is enough room to walk around the weight system as you assemble it.

How to Unpack the Box

To make assembly as easy as possible, we have divided the assembly process into four stages. The parts needed for each stage are found in individual bags. **Important: Wait until you begin each stage to open the parts bag for that stage.** Place all parts of the weight system in a cleared area and remove the packing materials. Do not dispose of the packing materials until assembly is completed.

Make sure you have the following tools:

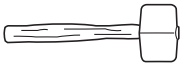
- Two adjustable wrenches 
- One standard screwdriver 
- One phillips screwdriver 
- One rubber mallet 
- You will also need grease or petroleum jelly, and a small amount of soapy water.

Note: Assembly will be more convenient if you have a socket set, a set of open-end or closed-end wrenches, or a set of ratchet wrenches.

How to Identify Parts

To help you identify the small parts used in assembly, we have included a **PART IDENTIFICATION CHART** in the center of this manual. Place the chart on the floor and use it to easily identify parts during each assembly step. **Note: Some small parts may have been pre-attached. If a part is not in the parts bag, check to see if it has been pre-attached.**

How to Orient Parts

As you assemble the weight system, orient all parts exactly as shown in the drawings.

Tightening Parts

Tighten all parts as you assemble them, unless instructed to do otherwise.

Questions?

If you have questions after reading the assembly instructions, please call our Customer Service Department toll-free at **1-800-999-3756** Monday through Friday, 6 a.m. until 6 p.m. Mountain Time.

The Four Stages of the Assembly Process

Frame Assembly—You will begin by assembling the base and the uprights that serve as the skeleton of the weight system.

Arm Assembly—During this stage you will assemble the press arm, leg lever, handles, and leg press.

Cable Assembly—During this stage you will attach the cables and pulleys that connect the arms and other parts to the weights.

Seat Assembly—During this stage you will assemble the seats, the backrests, the curl pad, the shroud, and other miscellaneous parts.

Frame Assembly

1. **Before beginning assembly, make sure you have read and understood the information on page 5. This brief introduction will save you much more time than it takes to read it.**

Open the parts bag labeled “FRAME ASSEMBLY.”

Press two 2" x 3" Inner Caps (24) into the ends of the Stabilizer (5). Press a 2" x 3" Inner Cap and a 2" Square Inner Cap (33) into the Main Upright (3) in the indicated locations.

Insert three 3/8" x 3 3/4" Carriage Bolts (52) and a 3/8" x 5" Carriage Bolt (82) into the indicated holes in the Stabilizer (5).

Attach the Main Upright (3) to the Stabilizer (5) with the two indicated 3/8" x 3 3/4" Carriage Bolts (52) and two 3/8" Nylon Locknuts (50). **Do not tighten the Nylon Locknuts yet.**

2. Press a 2" x 3" Inner Cap (24) into the end of the Base (8). Press two 2" Square Inner Caps (33) into the Leg Lever (29) and the front leg on the Base. **Note: Do not fully insert the 2" Square Inner Cap into the Base; it will need to be removed later to attach the Curl Post (not shown).**

Attach the Base (8) to the Main Upright (3) with a 3/8" x 4" Bolt (65), a 3/8" Washer (55), and a 3/8" Nylon Locknut (50). **The Bolt must be inserted from the side shown. Do not tighten the Nylon Locknut yet.**

Slide two 5/16" x 3" Bolts (78) through the Base (8) and the Main Upright (3), and hand tighten two 5/16" Nylon Locknuts (81) onto the Bolts. **Do not tighten the Nylon Locknuts yet.**

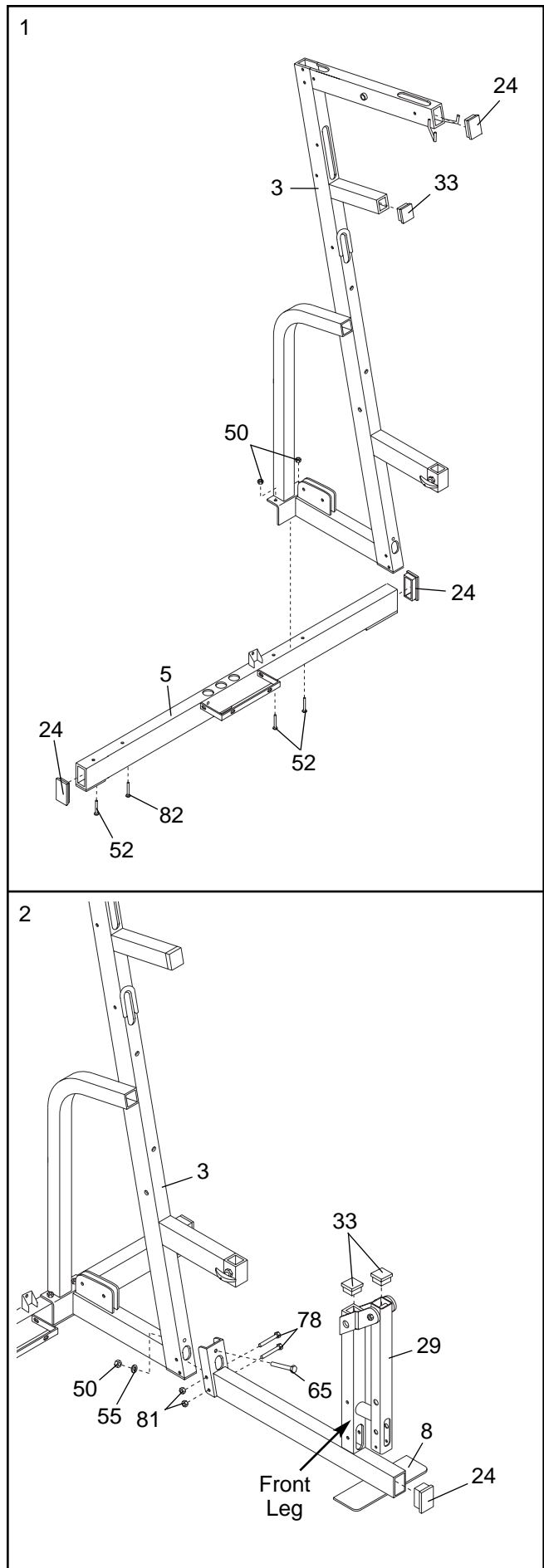

- Place two Weight Bumpers (19) over the indicated holes in the Stabilizer (5). Insert the two Weight Guides (23) into the Weight Bumpers and the Stabilizer.

Attach the indicated Weight Guide (23) to the Stabilizer (5) with a 3/8" x 2 1/2" Bolt (54), two 5/8" x 1/2" Bushings (42), two 3/8" Washers (55), and a 3/8" Nylon Jamnut (63).

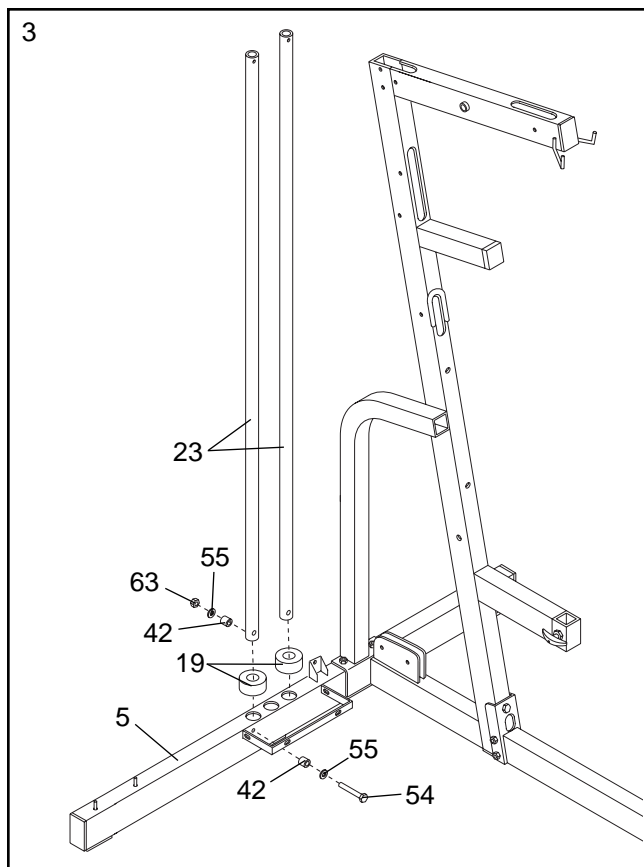

- Open the parts bag labeled "Weight Inserts."**

See the inset drawing. Press two Weight Inserts (77) into the indicated holes in each Weight (26). **Make sure the large pin groove is oriented as shown.**

Slide all nineteen Weights (26) onto the Weight Guides (23). **Make sure the Weights are oriented correctly; the pin grooves must be on the side shown.**

Press the Weight Tube Bumper (47) into the bottom of the Weight Tube (36).

Slide the Top Weight (16) onto the Weight Guides (23). Insert the Weight Tube (36) into the Weights (26).

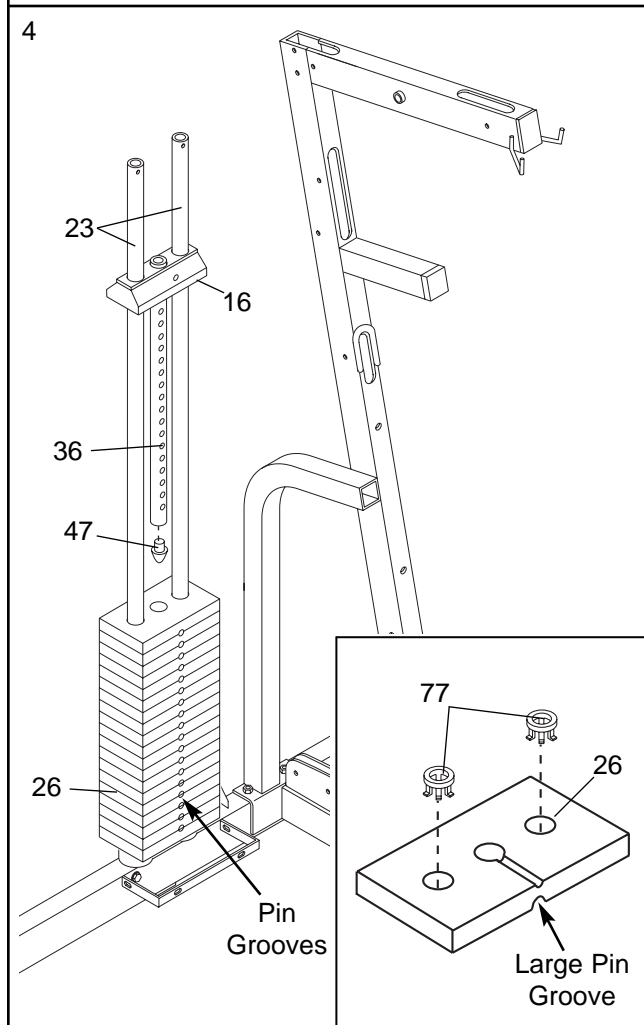

- Slide the welded tubes on the Top Frame (1) over the upper ends of the Weight Guides (23). Align the bracket on the Top Frame with the indicated holes in the Main Upright (3). Insert two 3/8" x 3" Bolts (45) into the holes. Thread a 3/8" Nylon Locknut (50) onto the lower Bolt. **Do not thread a Locknut onto the upper Bolt yet.**

Attach the Weight Guides (23) to the Top Frame (1) with two 3/8" x 1 3/4" Bolts (60) and two 3/8" Nylon Locknuts (50).

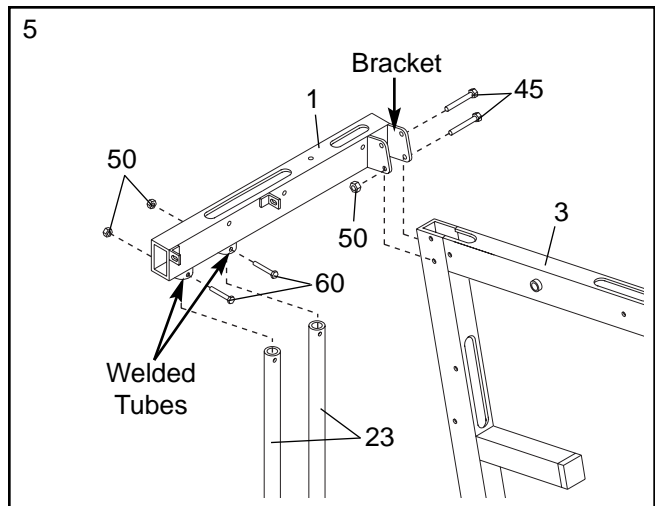

- Press a 2" x 3" Inner Cap (24) into the end of the Leg Press Base (84).

Slide the Leg Press Base (84) onto the 3/8" x 3 3/4" Carriage Bolt (52) and the 3/8" x 5" Carriage Bolt (82) in the Stabilizer (5). Tighten a 3/8" Nylon Locknut (50) onto the 3/8" x 3 3/4" Carriage Bolt. **Do not place a Nylon Locknut on the 3/8" x 5" Carriage Bolt yet.**

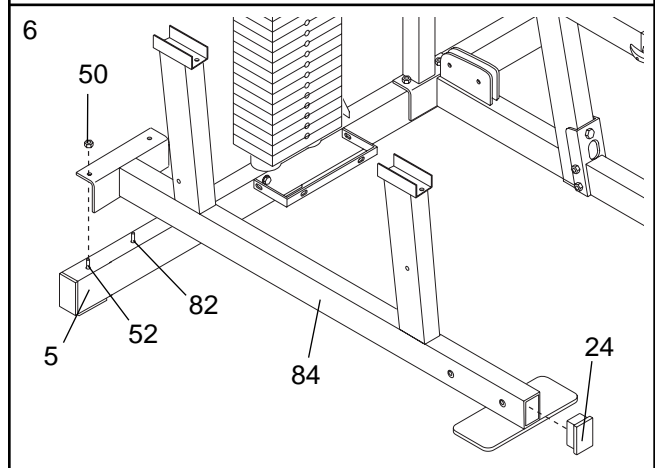

- Turn the Adjustment Knob (9) on the Sliding Seat Frame (74) counterclockwise to loosen it. Pull out the Knob as far as possible and slide the Sliding Seat Frame onto the Seat Frame Channel (88). Release the Knob and let it engage one of the adjustment holes in the Seat Frame Channel. Tighten the Knob fully.

Press a 2" Square Inner Cap (33) into the top of the Sliding Seat Frame (74). Press a 2" Square Inner Cap into the indicated end of the Seat Frame Channel (88). Press the Flat Plate (4) and the Angle Cap (99) onto the other end of the Seat Frame Channel.

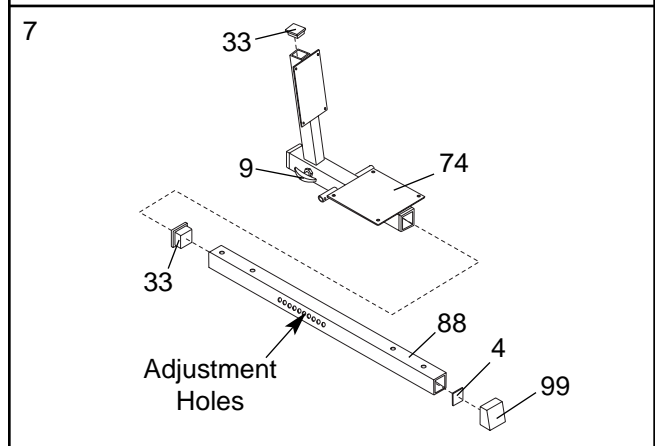

- Attach the Seat Frame Channel (88) to the Leg Press Base (84) with four 3/8" x 3" Carriage Bolts (64) and four 3/8" Nylon Locknuts (50).

Tighten the 3/8" Nylon Locknuts (50) used in steps 1 and 2.

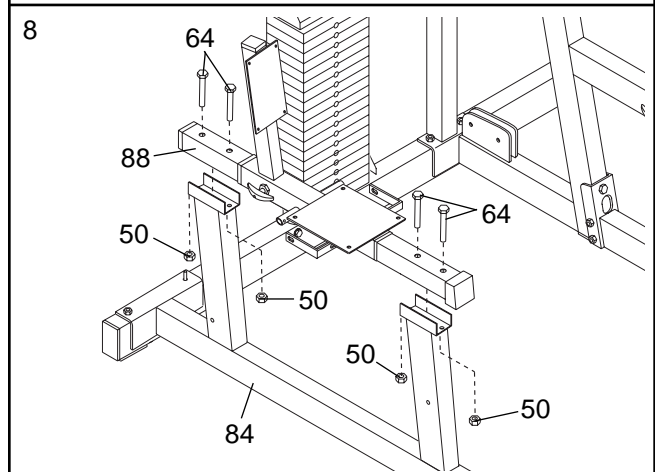

Arm Assembly

9. Open the parts bags labeled “ARM ASSEMBLY.”

Attach the Rear and Forward Leg Press Uprights (97, 98) to the Leg Press Base (84) with two 3/8" x 3 1/4" Bolts (87) and two 3/8" Nylon Locknuts (50). **Note: The Rear Leg Press Upright (97) has an extra hole in it.**

Press two 2" Square Inner Caps (33) into the Rear and Forward Leg Press Uprights (97, 98).

10. Attach the two Leg Press Attachments (100) to the Rear and Forward Leg Press Uprights (97, 98) with two 3/8" x 3 1/4" Bolts (87) and two 3/8" Nylon Jamnuts (63).

11. Attach the Leg Press Plate (85) to the Leg Press Attachments (100) with two 3/8" x 3 1/4" Bolts (87), eight 3/8" Washers (55), and two 3/8" Nylon Jamnuts (63).

Note: All eight of the 3/8" Washers (55) must be between the Leg Press Attachments (100) and the welded tube on the Leg Press Plate (85).

12. Attach a Handle (95) to the Sliding Seat Frame (74) with two 1/4" x 1 1/2" Bolts (101) and two 1/4" Nylon Locknuts (25).

Attach the other Handle (95) in the same manner.

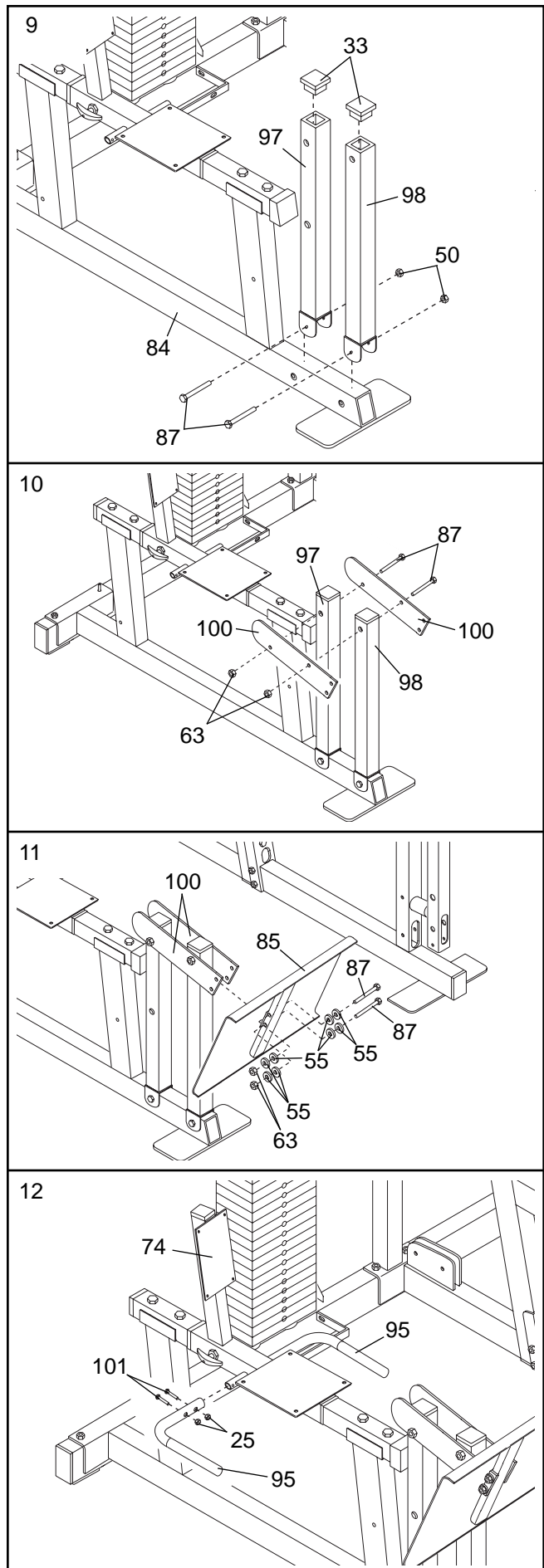

13. Attach the Leg Lever Lock (11) to the front leg of the Base (8) with a 5/16" x 3" Bolt (78), three 5/16" Washers (80), and a 5/16" Nylon Locknut (81). **Do not overtighten the Nylon Locknut; the Leg Lever Lock must pivot easily.**

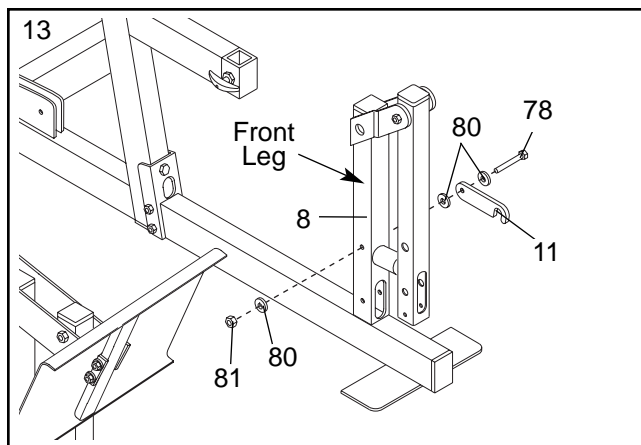

14. Press two 2" Square Inner Caps (33) into the top of the Press Frame (12). Press two 3/4" x 1/2" Flange Bushings (18) into the Main Upright (3).

Remove the 3/8" x 9" Bolt (51), the two 3/8" USS Washers (104), and the 3/8" Nylon Locknut (50) from the Press Frame (12). Lubricate the Bolt with grease. Attach the Press Frame to the Main Upright (3) with the Bolt, Washers, and Locknut. **Do not overtighten the Bolt and Locknut; the Press Frame must be able to pivot easily.**

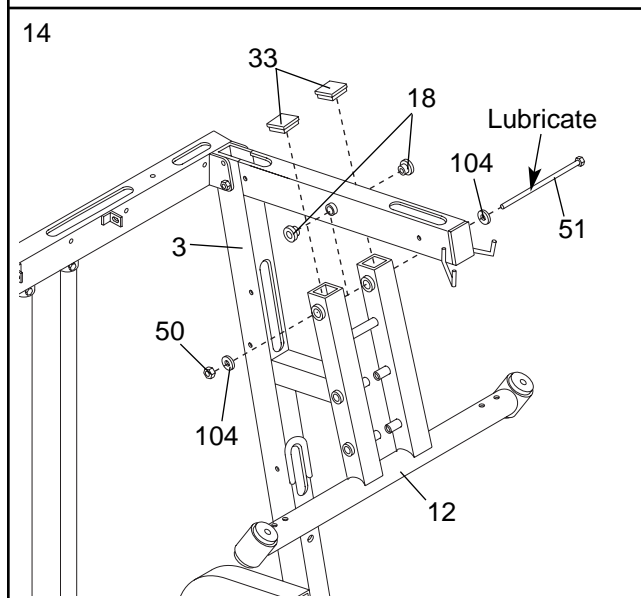

15. Lubricate the flat surfaces of the four Large Bushings (48).

Attach the Left Press/Fly Arm (49) to the Press Frame (12) with a 3/8" x 3" Carriage Bolt (64) and a 3/8" Nylon Jamnut (63). **Make sure to attach the Left Press/Fly Arm on the correct side by noting the position of the tab.**

Press a 2" Round Inner Cap (57) and a 1" Round Inner Cap (103) into the Left Press/Fly Arm (49).

Wet the handle on the Left Press/Fly Arm (49) with soapy water. Slide an Arm Grip (58) onto the handle.

Insert an Adjustment Pin (20) into the Press Frame (12) and the hole in the tab on the Left Press/Fly Arm (49).

Repeat this step with the Right Press/Fly Arm (46).

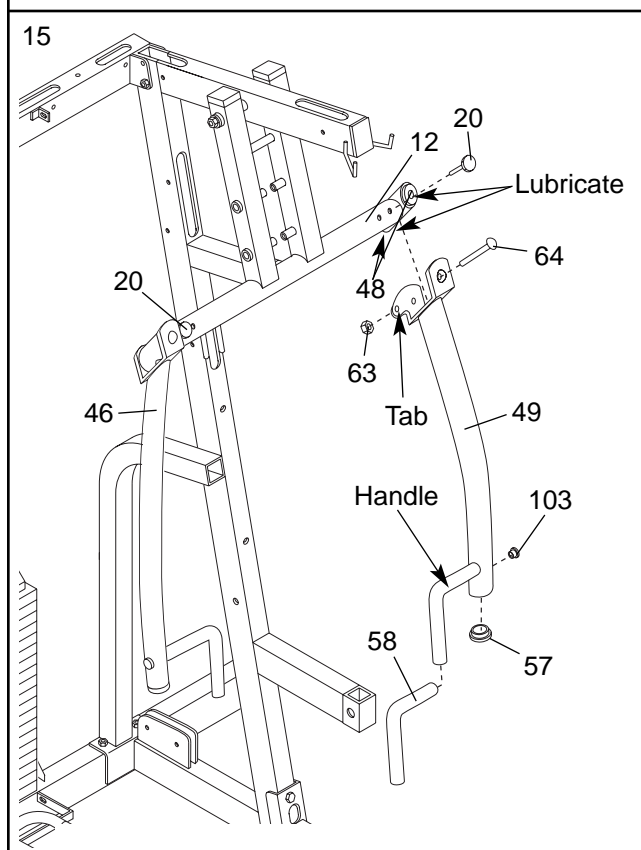

Cable Assembly

16. Open the parts bags labeled “CABLE ASSEMBLY” and “4 PULLEYS.” Refer to the CABLE DIAGRAM on page 21 to identify the cables and for correct cable routing.

Locate the Leg Press Cable (76). Attach the Leg Press Cable to the indicated hole in the Leg Press Base (84) with a 3/8" x 3" Bolt (45), two 3/8" Washers (55), a 5/8" x 1/4" Bushing (90), and a 3/8" Nylon Jamnut (63).

17. Wrap the Leg Press Cable (76) up around a 4" Pulley (35). Attach the Pulley and a Cable Trap (44) to the Rear Leg Press Upright (97) with a 3/8" x 3 3/4" Bolt (92), a 3/8" Washer (55), and a 3/8" Nylon Locknut (50).

Be sure that the Leg Press Cable (76) is routed in the direction shown, and that the Cable Trap (44) is positioned to hold the Cable in the pulley groove.

18. Route the Leg Press Cable (76) under a 4" Pulley (35). Attach the Pulley and a Cable Trap (44) to the Leg Press Base (84) with a 3/8" x 3 3/4" Bolt (92), a 3/8" Washer (55), and a 3/8" Nylon Locknut (50). **Be sure that the Cable Trap (44) is positioned to hold the Cable in the pulley groove.**

19. Wrap the Leg Press Cable (76) around a 4" Pulley (35). Attach the Pulley and a Cable Trap (44) to the 3/8" x 5" Carriage Bolt (82) in the Stabilizer (5) with a 3/8" Nylon Locknut (50).

Be sure that the Leg Press Cable (76) is routed in the direction shown, and that the Cable Trap (44) is positioned to hold the Cable in the pulley groove.

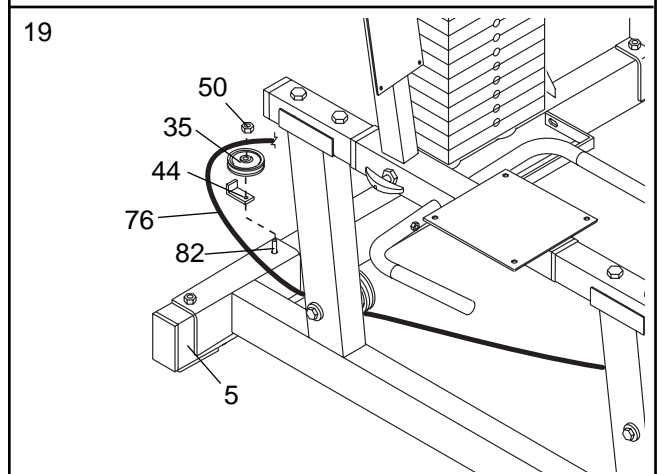
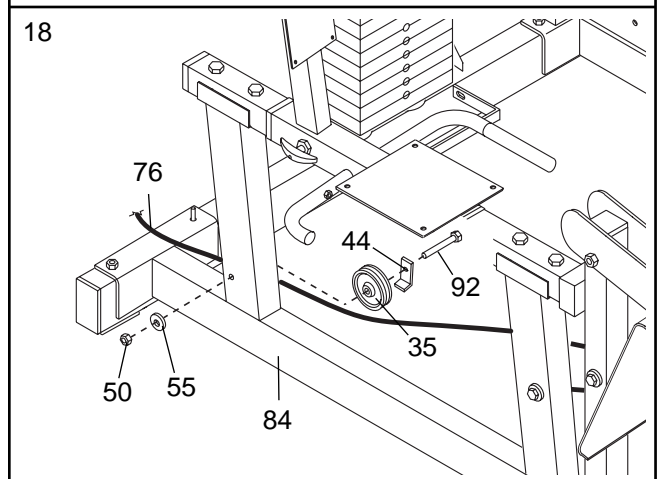
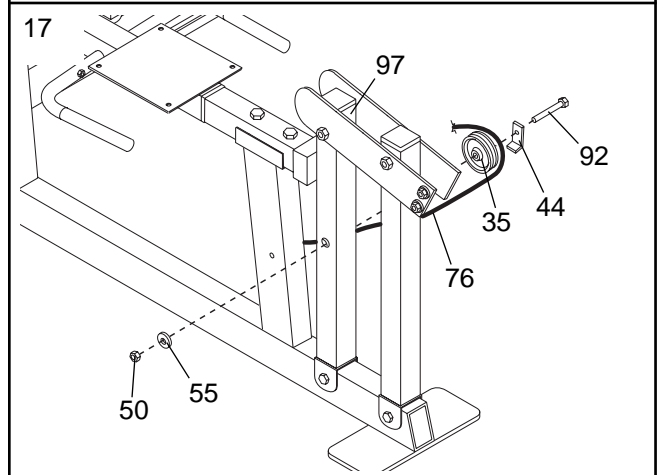
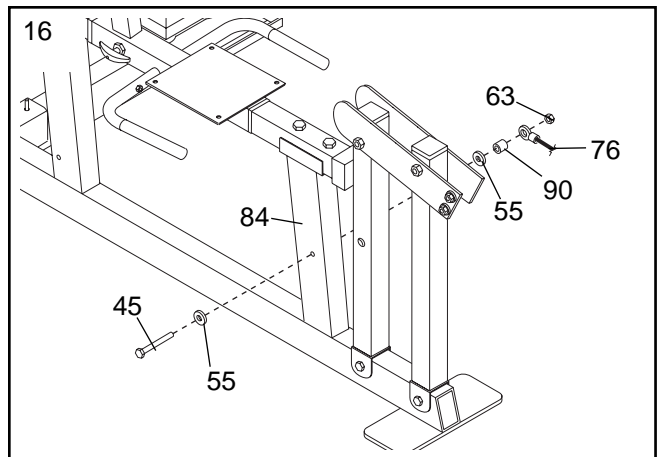

20. Wrap the Leg Press Cable (76) around a 4" Pulley (35). Attach the Pulley and a Cable Trap (44) to the bracket on the Stabilizer (5) with a 3/8" x 2" Bolt (62) and a 3/8" Nylon Locknut (50).

Be sure that the Cable Trap (44) is positioned to hold the Cable in the pulley groove.

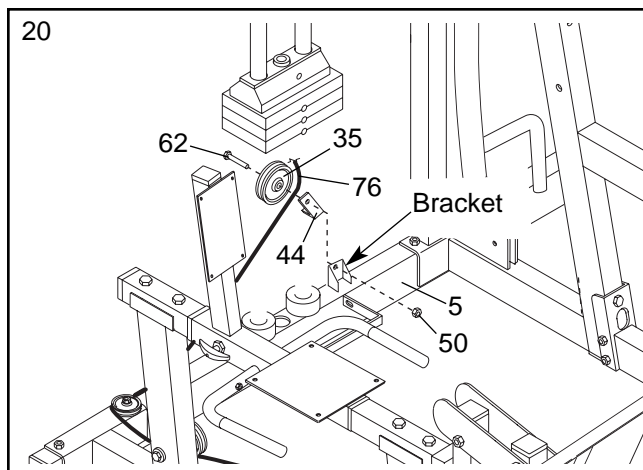

21. Remove the pre-assembled 4" Pulley (not shown) from the Pulley Bracket (91).

Attach the end of the Leg Press Cable (76) to the Pulley Bracket (91) with a 1/4" Washer (71) and a 1/4" Nylon Locknut (25).

Lay the Pulley Bracket (91) and the Leg Press Cable (76) aside; they will be attached in step 29.

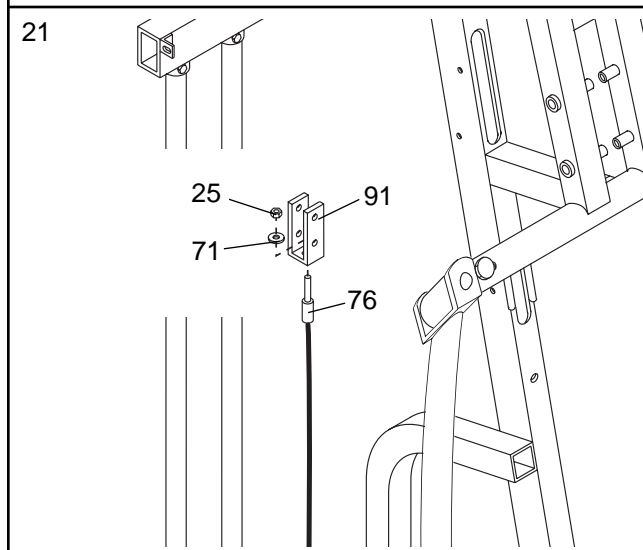

22. **Locate the High Cable (73).** Feed the bolt end of the High Cable up through the indicated slot in the Main Upright (3). Feed almost all of the Cable through the slot.

Slide a 3/8" Washer (55) and a 5/8" x 1/2" Bushing (42) onto a 3/8" x 2 1/2" Bolt (54).

Wrap the High Cable (73) around a 4" Pulley (35). Hold the Pulley inside the indicated slot in the Main Upright (3). Insert the 3/8" x 2 1/2" Bolt (54) through the Main Upright and the Pulley.

Slide another 5/8" x 1/2" Bushing (42) and 3/8" Washer (55) onto the 3/8" x 2 1/2" Bolt (54). Tighten a 3/8" Nylon Jamnut (63) onto the Bolt.

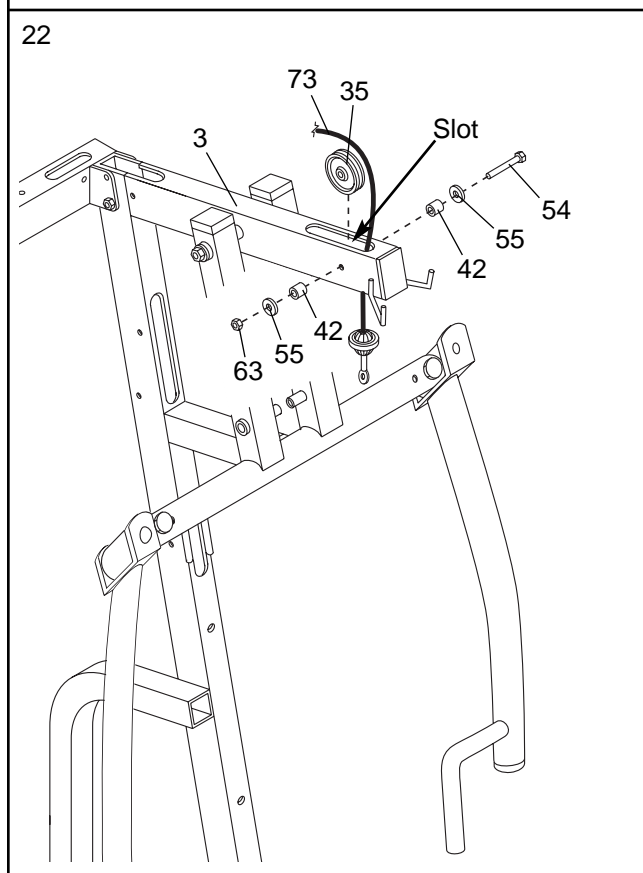

23. Remove the upper 3/8" x 3" Bolt (45) from the Top Frame (1) and the Main Upright (3).

Route the High Cable (73) around a 4" Pulley (35) and down through the indicated slot in the Main Upright (3), as shown. Attach the Pulley inside the slot with a 3/8" x 2 1/2" Bolt (54), two 3/8" Washers (55), two 5/8" x 1/2" Bushings (42), and a 3/8" Nylon Jamnut (63).

Re-insert the 3/8" x 3" Bolt (45) and secure it with a 3/8" Nylon Locknut (50). **Note: The High Cable (73) must be seated in the groove of the 4" Pulley (35) before the Bolt is inserted.**

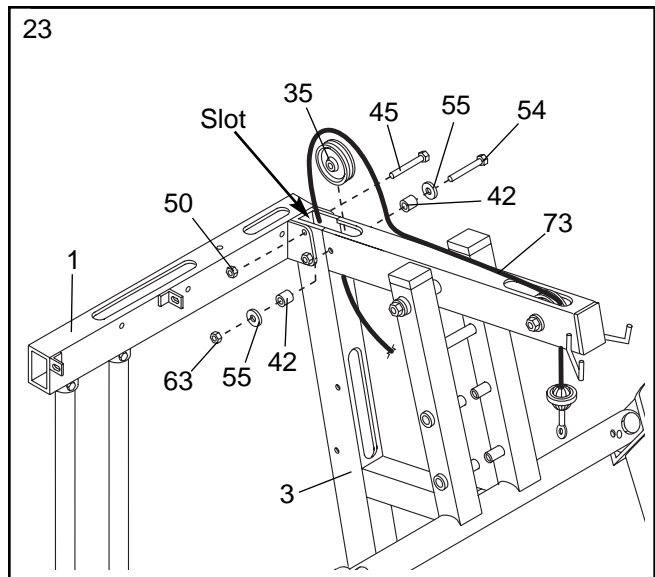

24. Route the High Cable (73) under the welded tube on the Press Frame (12) and around a 4" Pulley (35) as shown. Attach the Pulley to the Press Frame with a 3/8" x 8 1/2" Bolt (59) and a 3/8" Nylon Locknut (50).

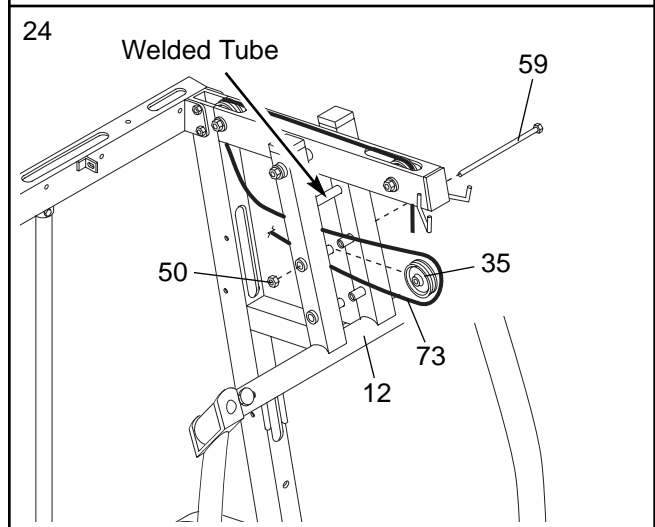

25. Wrap the High Cable (73) around a 4" Pulley (35). Attach the Pulley inside the indicated slot in the Main Upright (3) with a 3/8" x 2 1/2" Bolt (54), two 3/8" Washers (55), two 5/8" x 1/2" Bushings (42), and a 3/8" Nylon Jamnut (63).

Wrap the High Cable (73) around another 4" Pulley (35) in the direction shown. Route the High Cable through the slot in the Main Upright (3). Attach the Pulley to the Press Frame (12) with a 3/8" x 8 1/2" Bolt (59) and a 3/8" Nylon Locknut (50).

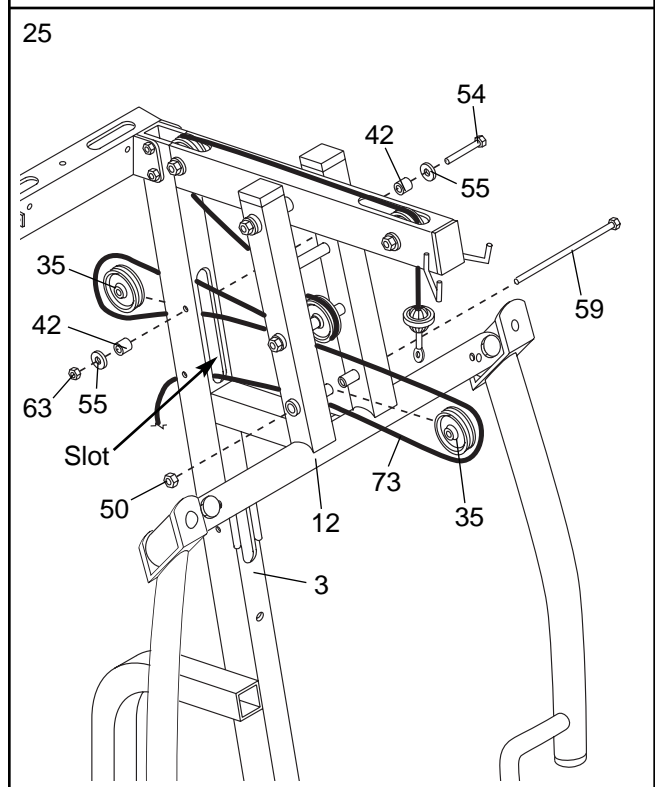

26. Wrap the High Cable (73) around a 4" Pulley (35). Attach the Pulley inside the slot in the Main Upright (3) with a 3/8" x 2 1/2" Bolt (54), two 3/8" Washers (55), two 5/8" x 1/2" Bushings (42), and a 3/8" Nylon Jamnut (63).

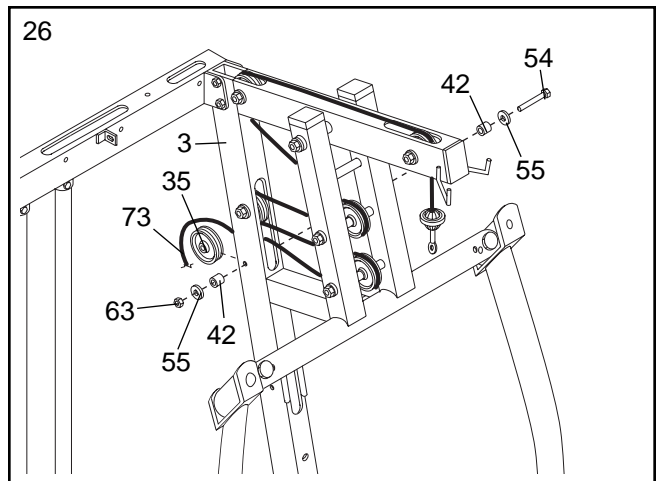

27. Disassemble the pre-assembled Pulley Plates (31).

Wrap the High Cable (73) around a 4" Pulley (35) in the direction shown. Attach the Pulley and a Cable Trap (44) to the top set of holes in the end of the Pulley Plates (31) with a 3/8" x 1 3/4" Bolt (60) and a 3/8" Nylon Jamnut (63). **Make sure the Cable is in the groove of the Pulley and that the Cable Trap is oriented to hold the Cable in place.**

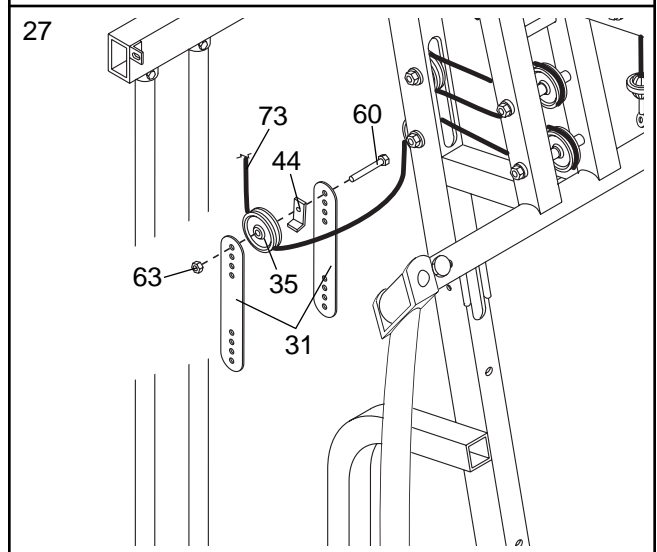

28. Route the High Cable (73) up through the indicated slot in the Top Frame (1), over a 4" Pulley (35), and back down through the Top Frame.

Attach the 4" Pulley (35) inside the slot in the Top Frame (1) with a 3/8" x 2 1/2" Bolt (54), two 3/8" Washers (55), two 5/8" x 1/2" Bushings (42), and a 3/8" Nylon Jamnut (63).

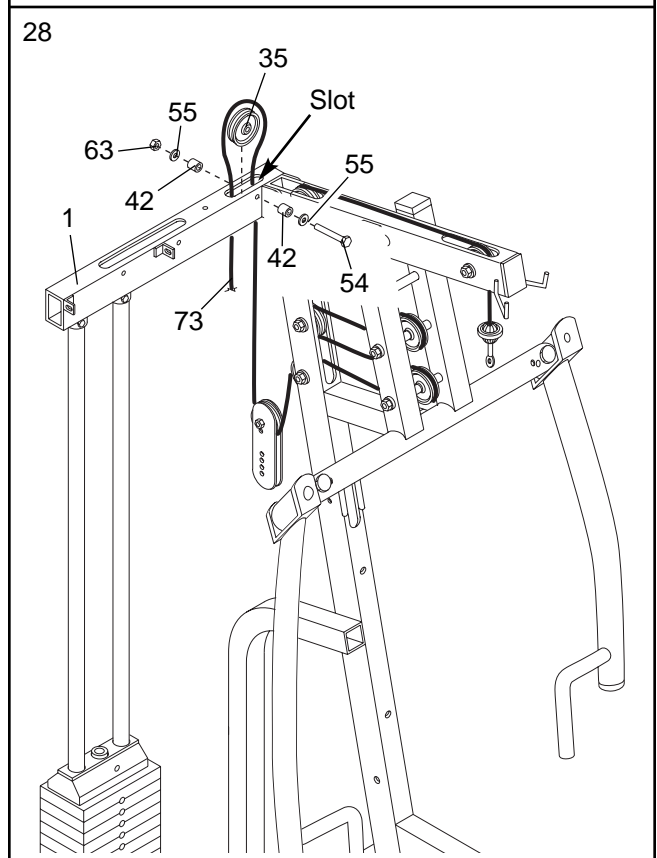

29. Wrap the High Cable (73) around a 4" Pulley (35). Attach the Pulley and a Cable Trap (44) to the top hole in the Pulley Bracket (91) attached to the Leg Press Cable (76), with a 3/8" x 1 3/4" Bolt (60) and a 3/8" Nylon Jamnut (63).

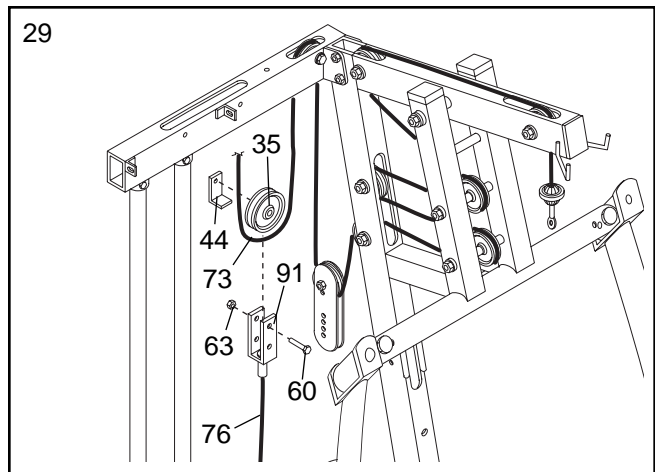

30. Route the High Cable (73) up through the next slot in the Top Frame (1) and wrap the Cable around a 4" Pulley (35) in the direction shown.

Attach the 4" Pulley (35) to the Top Frame (1) with a 3/8" x 2 1/2" Bolt (54), two 3/8" Washers (55), two 5/8" x 1/2" Bushings (42), and a 3/8" Nylon Jamnut (63).

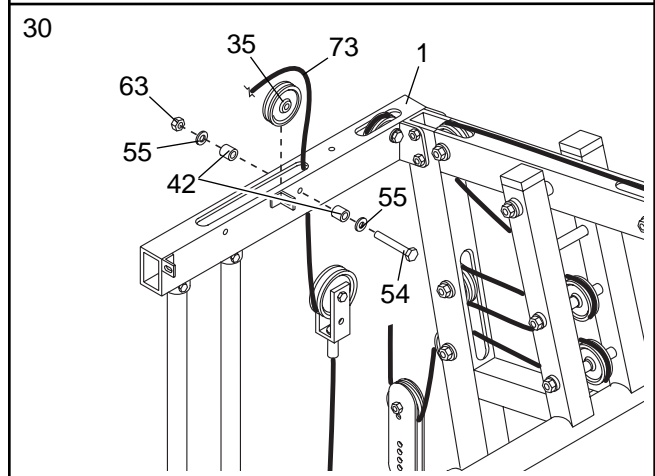

31. Route the High Cable (73) around a 4" Pulley (35) and down through the indicated slot in the Top Frame (1).

Attach the 4" Pulley (35) to the Top Frame (1) with a 3/8" x 2 1/2" Bolt (54), two 3/8" Washers (55), two 5/8" x 1/2" Bushings (42), and a 3/8" Nylon Jamnut (63).

Let the High Cable (73) hang over the weight stack; it will be attached in step 38.

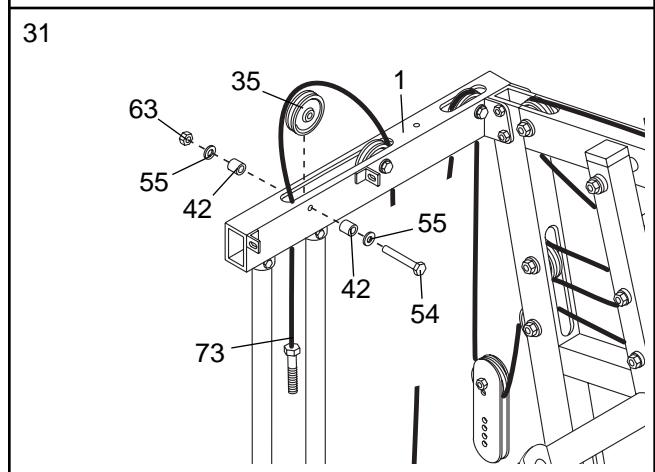

32. **Locate the Low Cable (72), which has a ball on each end.** Route the Low Cable through the slots in the Leg Lever (29) and the Base (8).

Attach a 4" Pulley (35) inside the Leg Lever (29) with a 3/8" x 2 1/2" Bolt (54), two 3/8" Washers (55), two 5/8" x 1/2" Bushings (42), and a 3/8" Nylon Jamnut (63).

Attach the 1/2" x 1 3/4" Bushing (94) inside the bottom of the Leg Lever (29) with a 5/16" x 2 1/2" Bolt (96), two 5/16" Washers (80), and a 5/16" Nylon Jamnut (79). Press a 2" Square Inner Cap (33) into the bottom of the Leg Lever. **Note: It may be easier to attach the 2" Square Inner Cap if you pivot the Leg Lever upward.**

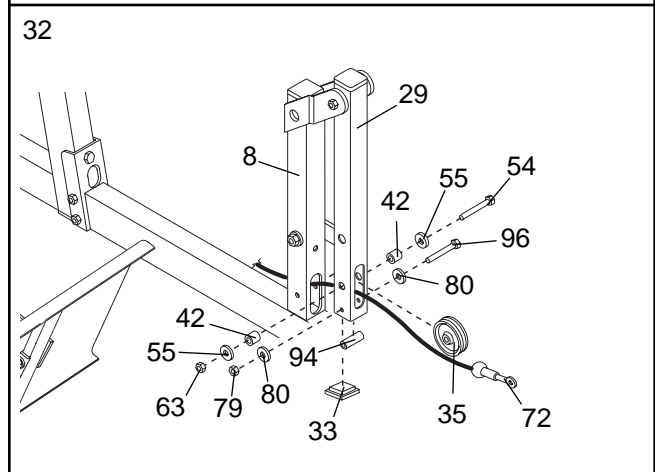

33. Attach a 4" Pulley (35) over the Low Cable (72), inside the front leg of the Base (8) with a 3/8" x 2 1/2" Bolt (54), two 3/8" Washers (55), two 5/8" x 1/2" Bushings (42), and a 3/8" Nylon Jamnut (63).

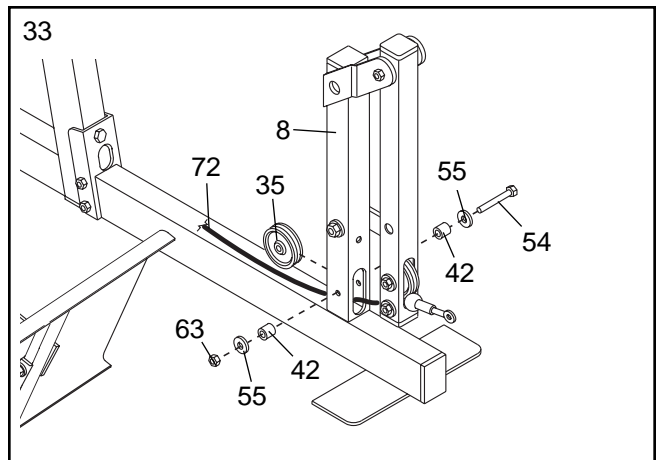

34. Route the Low Cable (72) through the indicated slot in the Main Upright (3) and the Base (8).

Wrap the Low Cable (72) around a 4" Pulley (35) in the direction shown. Attach the Pulley inside the bracket on the Main Upright (3) with a 3/8" x 2" Bolt (62) and a 3/8" Nylon Locknut (50).

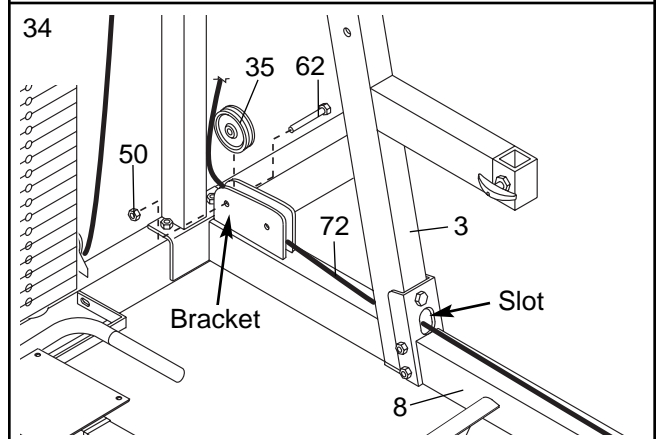

35. Wrap the Low Cable (72) over a 4" Pulley (35). Slide the Pulley and a Cable Trap (44) between the two Pulley Plates (31). **Make sure the Cable is in the groove of the Pulley and that the Cable Trap is oriented so it will hold the Cable in place.**

Attach the 4" Pulley (35) and the Cable Trap (44) to the third set of holes from the bottom of the Pulley Plates (31) with a 3/8" x 1 3/4" Bolt (60) and a 3/8" Nylon Jamnut (63).

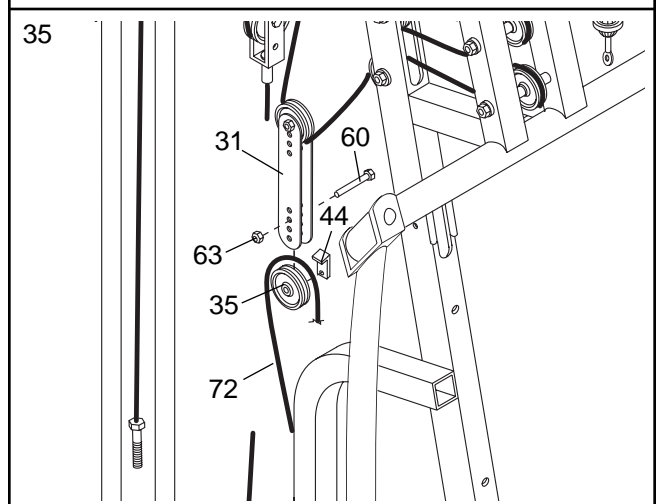

36. Wrap the Low Cable (72) around a 4" Pulley (35). Attach the Pulley inside the bracket on the Main Upright (3) with a 3/8" x 2" Bolt (62) and a 3/8" Nylon Locknut (50).

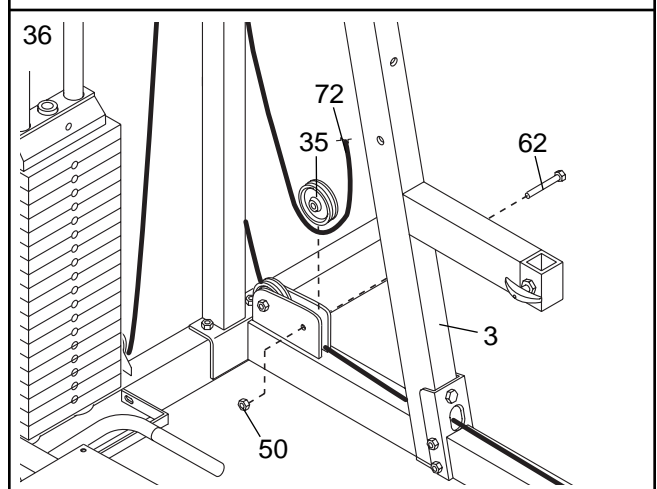

37. Route the end of the Low Cable (72) through the indicated slot in the Main Upright (3).

Wrap the Low Cable (72) around a 4" Pulley (35). Attach the Pulley inside the slot in the Main Upright (3) with a 3/8" x 2 1/2" Bolt (54), two 3/8" Washers (55), two 5/8" x 1/2" Bushings (42), and a 3/8" Nylon Jamnut (63).

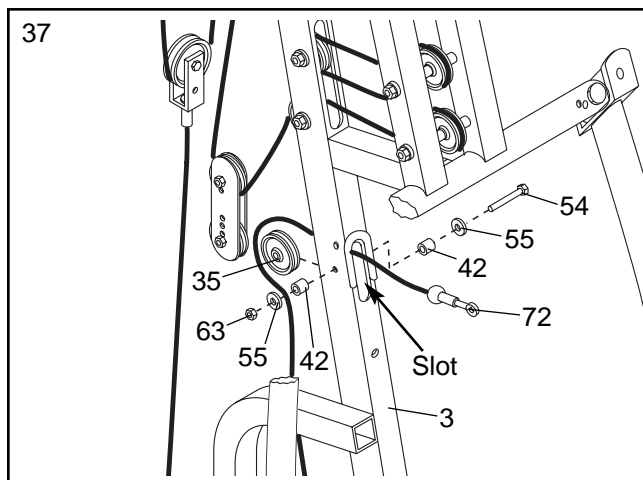

38. **IMPORTANT: Follow the cables from end to end; make sure that they are in the grooves of the pulleys and that the cables and pulleys move smoothly.**

Thread the 1/2" Plain Nut (68) part way onto the bolt at the end of the High Cable (73). Place the 1 1/2" Washer (40) on top of the Weight Tube (36).

Insert the bolt on the High Cable (73) through the ring on the Weight Pin (39) and into the threaded hole in the Weight Tube (36). Tighten the bolt into the Weight Tube until the Cables (73, 72, 76) are tight.

Tighten the 1/2" Plain Nut (68) against the 1 1/2" Washer (40).

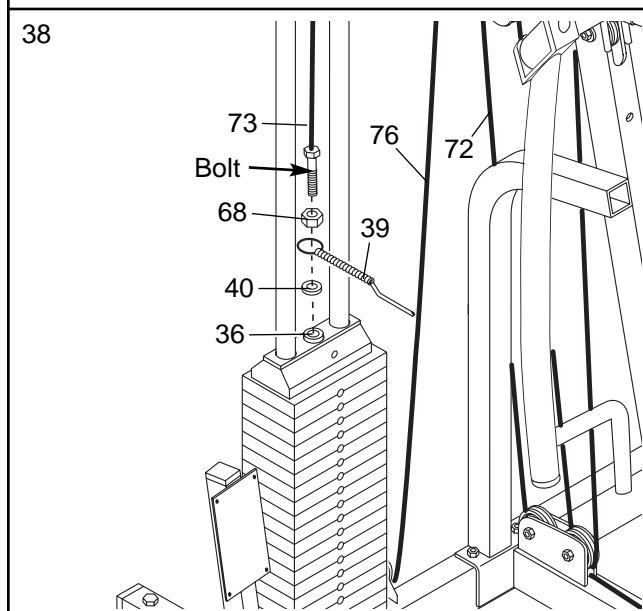

Seat Assembly

39. **Open the parts bag labeled "ARM AND SEAT ASSEMBLY."**

Attach a Seat (13) to the Seat Upright (37) with four 1/4" x 3/4" Bolts (17).

Turn the Adjustment Knob (9) on the Main Upright (3) counterclockwise to loosen it and pull it out as far as possible. Slide the Seat Upright (37) into the Main Upright. Release the Knob and let it engage one of the adjustment holes in the Seat Upright. Retighten the Knob.

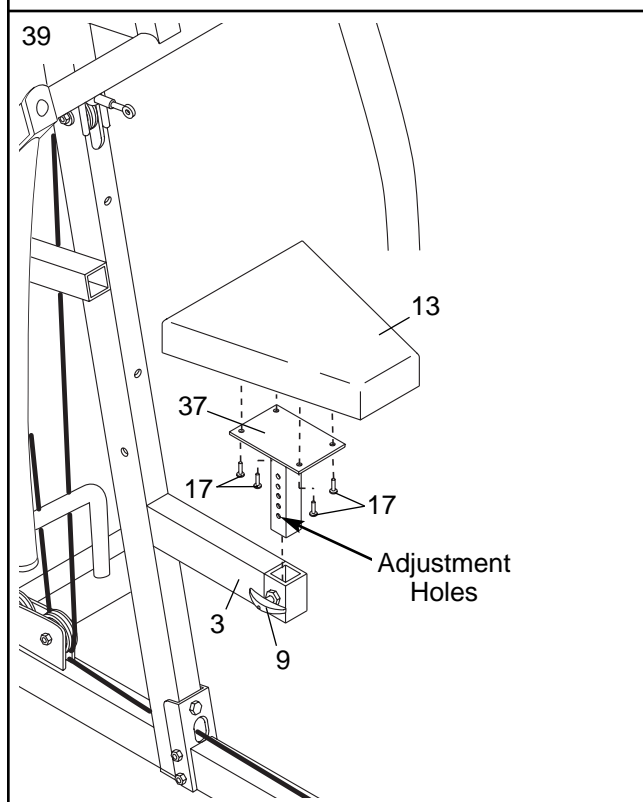

40. Insert a 1/4" x 3 3/4" Carriage Bolt (43) into each Backrest Plate (27). Attach the Backrest Plates to the Backrest (41) with four 1/4" x 3/4" Bolts (17).

Attach the Backrest (41) to the Main Upright (3) with the two 1/4" x 3 3/4" Carriage Bolts (43), two 1/4" Washers (71), and two 1/4" Nylon Locknuts (25). **Be sure the Backrest is oriented as shown.**

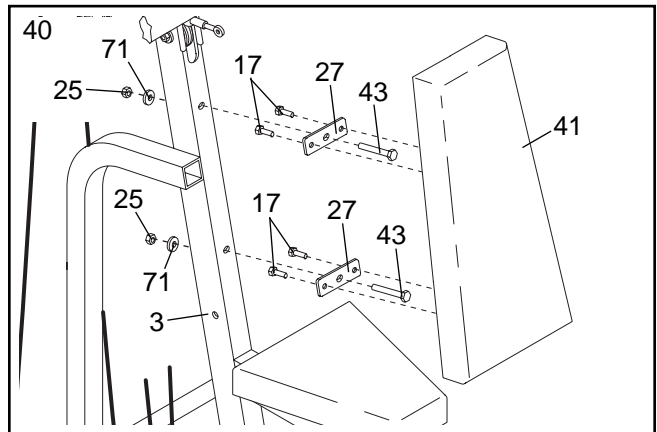

41. Attach the other Seat (13) to the Sliding Seat Frame (74) with four 1/4" x 3/4" Bolts (17).

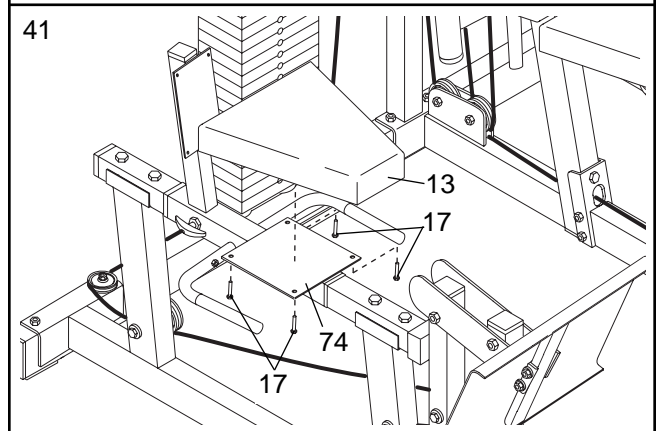

42. Attach the Leg Press Backrest (70) to the Sliding Seat Frame (74) with four 1/4" x 3/4" Bolts (17).

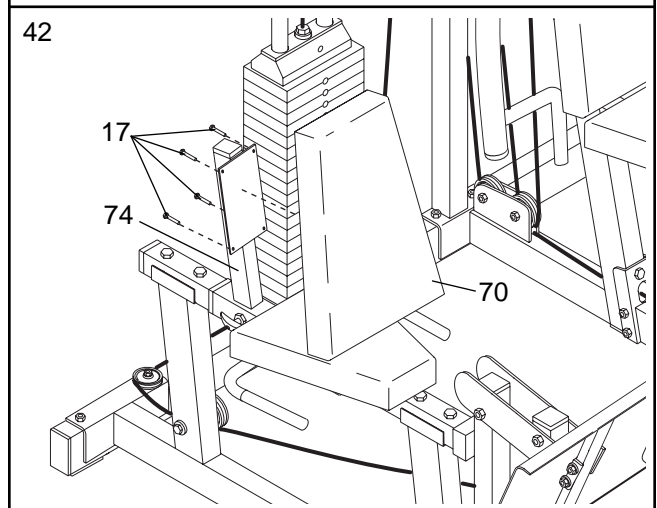

43. Press four 3/4" Round Inner Caps (34) into the ends of two Pad Tubes (28).

Slide a Pad Tube (28) through the hole in the front leg on the Base (8). Slide two Foam Pads (30) onto the ends of the Pad Tube.

Slide the other Pad Tube (28) through the hole in the Leg Lever (29). Slide two Foam Pads (30) onto the ends of the Pad Tube.

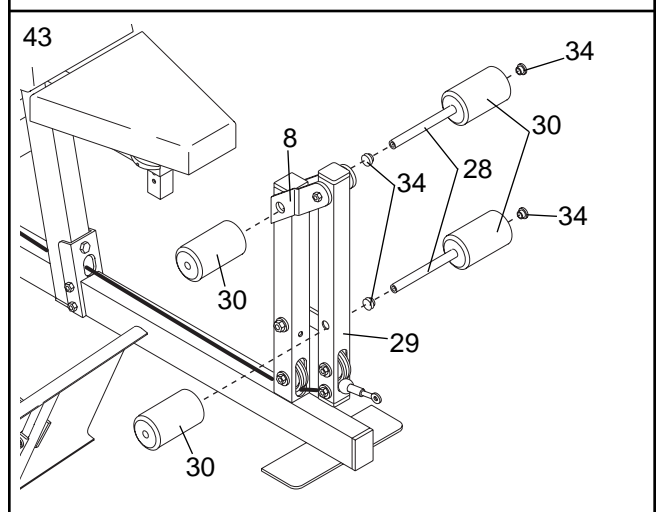

44. Press two 3/4" Round Inner Caps (34) into the ends of the remaining Pad Tube (28).

Slide the Pad Tube (28) through the hole in the Main Upright (3). Slide two Foam Pads (30) onto the ends of the Pad Tube.

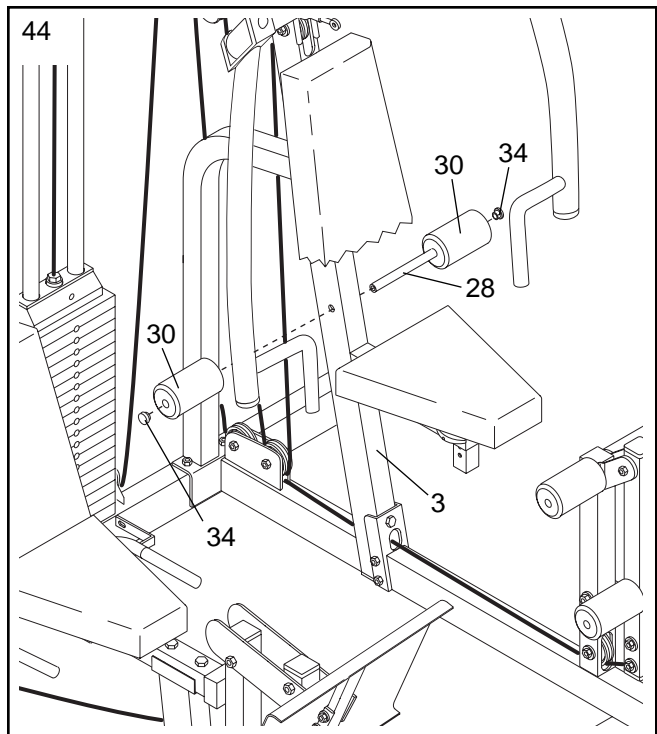

45. Slide the two Tinnerman Clips (38) down over the slots in the bracket on the Stabilizer (5).

Attach the lower end of the Shroud (56) to the bracket on the Stabilizer (5) with two #8 x 3/4" Screws (32). The Screws must be inserted through the square holes in the Shroud and into the Tinnerman Clips (38).

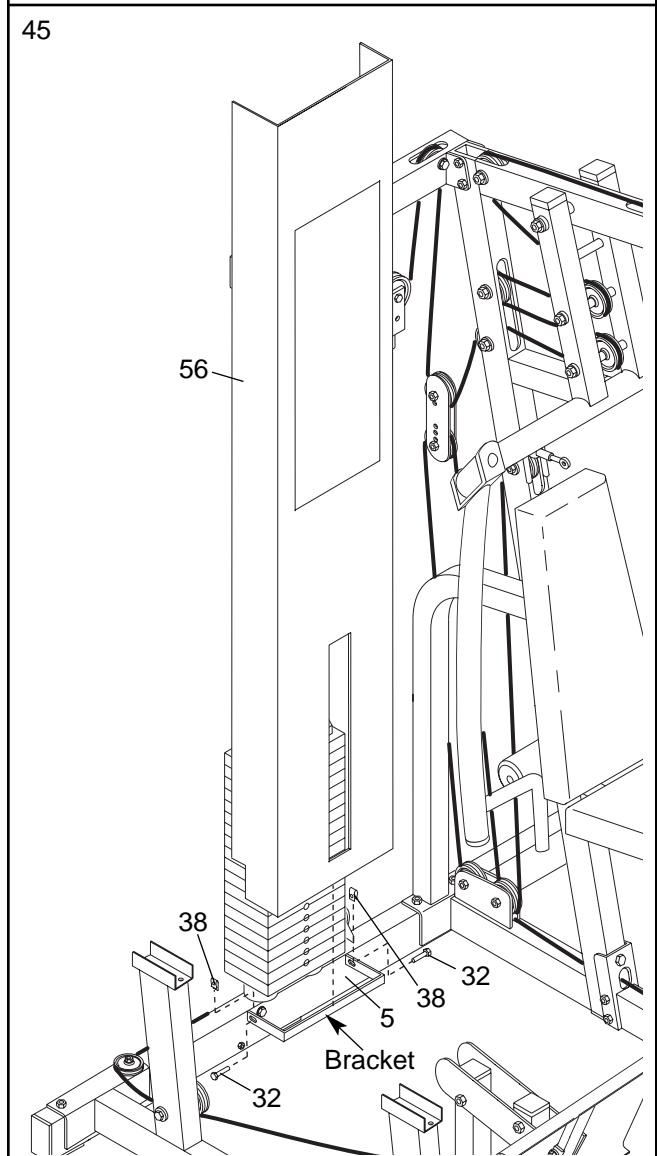

46. Attach the upper end of the Shroud (56) to the two “L”-brackets on the Top Frame (1) with two 1/4” x 3/4” Bolts (17), two 1/4” Washers (71), and two 1/4” Nylon Locknuts (25). **Make sure that the indicated corner of the Shroud is lined up with the indicated corner of the Top Frame. The Bolts must be inserted through the square holes in the Shroud.**

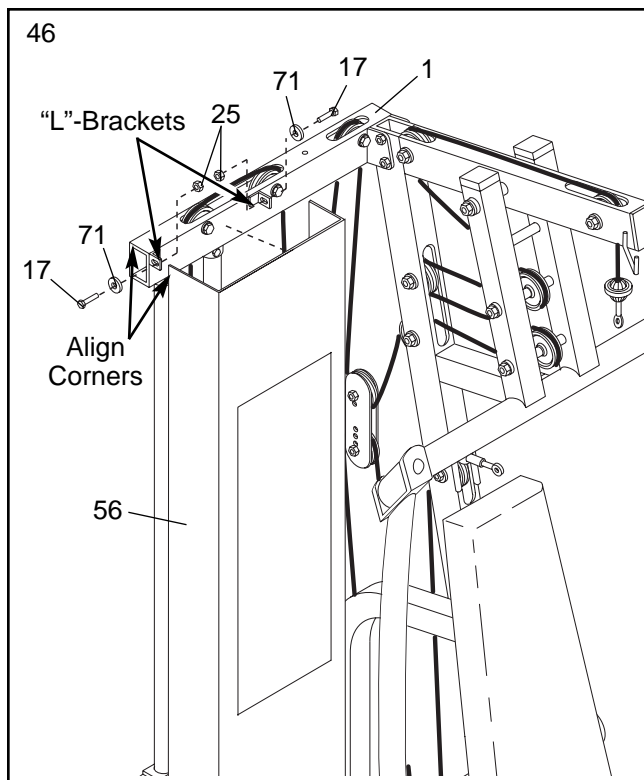

47. Attach the Curl Pad (21) to the Curl Post (83) with four 1/4” x 3/4” Bolts (17).

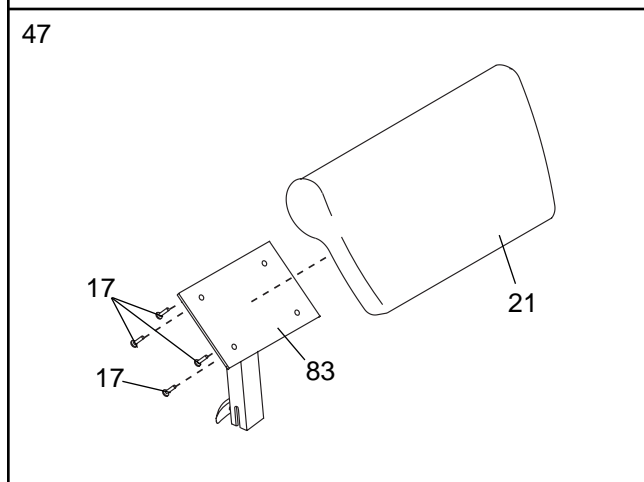

48. Make sure that all parts have been properly tightened. The use of the remaining parts will be explained in ADJUSTMENTS, beginning on page 22 of this manual.

Before using the weight system, pull each cable a few times to make sure that the cables move smoothly over the pulleys. If one of the cables does not move smoothly, find and correct the problem. **IMPORTANT: If the cables are not properly installed, they may be damaged when heavy weight is used. If there is any slack in the cables, you will need to remove the slack by tightening the cables. See TROUBLESHOOTING AND MAINTENANCE on page 25.**

CABLE DIAGRAM

The diagram below shows the proper routing of the Low Cable (72), the High Cable (73), and the Leg Press Cable (76). The numbers show the correct route for each cable. **Make sure that the cables are routed correctly, that the pulleys move smoothly, and that the cable traps do not touch or bind the cables.** Incorrect cable routing can damage the weight system.

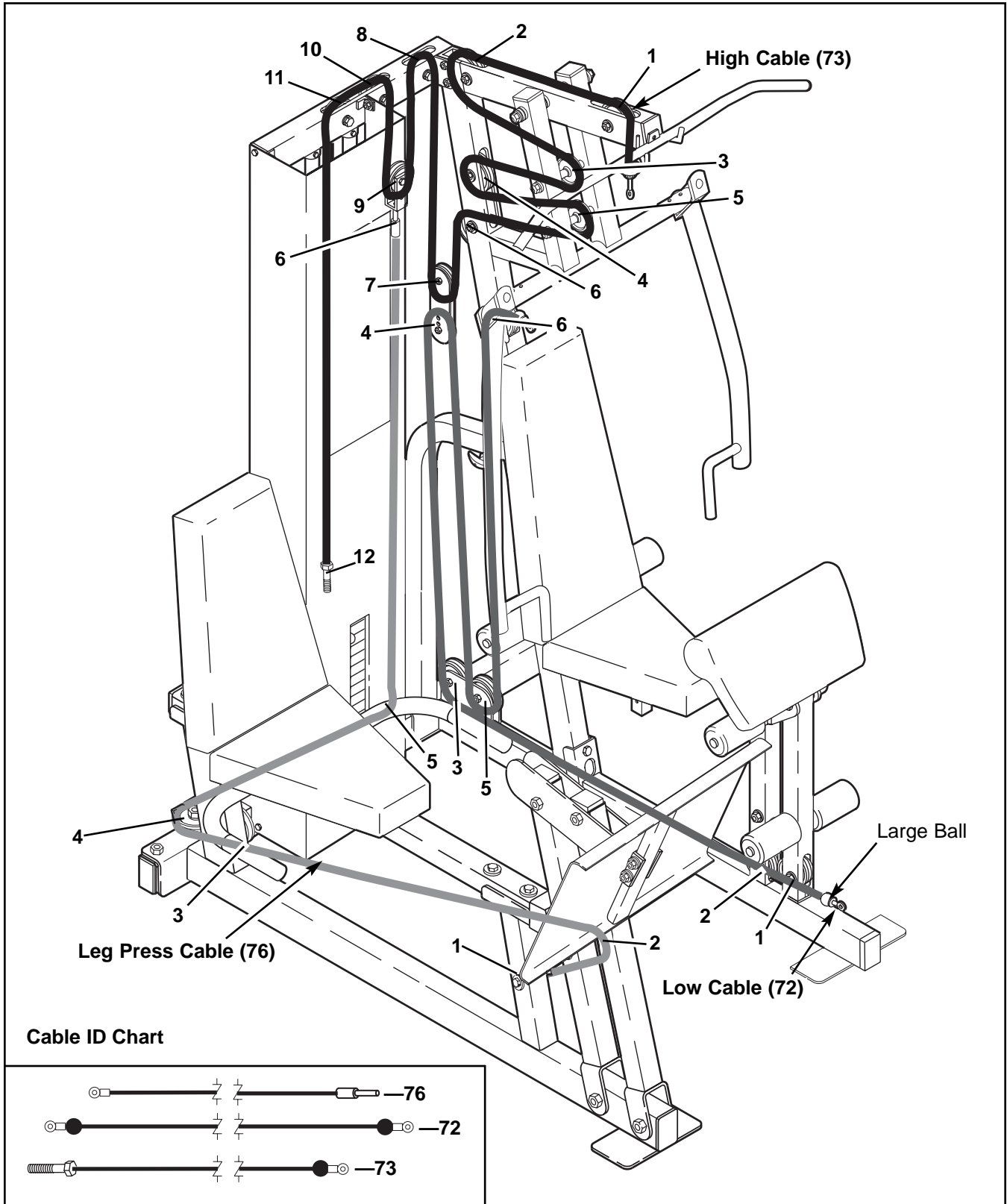

ADJUSTMENTS

The instructions below describe how each part of the weight system can be adjusted. Refer to the exercise guide accompanying this manual to see how the weight system should be set up for each exercise. **IMPORTANT: When attaching the lat bar, ankle strap, or ab strap, make sure that the accessories are in the correct starting position for the exercise to be performed. If there is any slack in the cables or chain as an exercise is performed, the effectiveness of the exercise will be reduced.**

CHANGING THE WEIGHT SETTING

To change the setting of the weight stack, insert the Weight Pin (39) under the desired Weight (26). Be sure to insert the Weight Pin until the bent end of the Weight Pin is touching the Weights, and turn the bent end downward. The setting of the weight stack can be changed from 10 pounds to 200 pounds, in increments of 10 pounds. **Note: Due to the cables and pulleys, the amount of resistance at each exercise station may vary from the weight setting. Use the WEIGHT RESISTANCE CHART on page 24 of this manual to find the approximate amount of resistance at each weight station.**

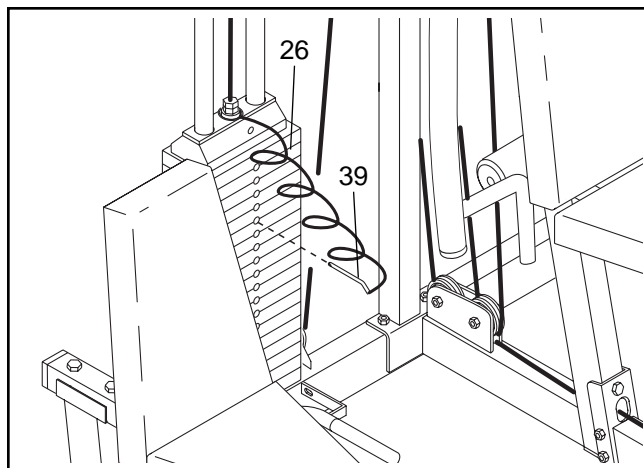

ATTACHING THE ACCESSORIES

The Lat Bar (61), Ankle Strap (10), and Ab Strap (75) can be attached to the cable at the desired pulley station with a Cable Clip (69). For some exercises, the Chain (67) should be connected between the attachment and the cable with two Cable Clips. **Adjust the length of the Chain between the accessory and the cable so the accessory is in the correct starting position for the exercise to be performed.**

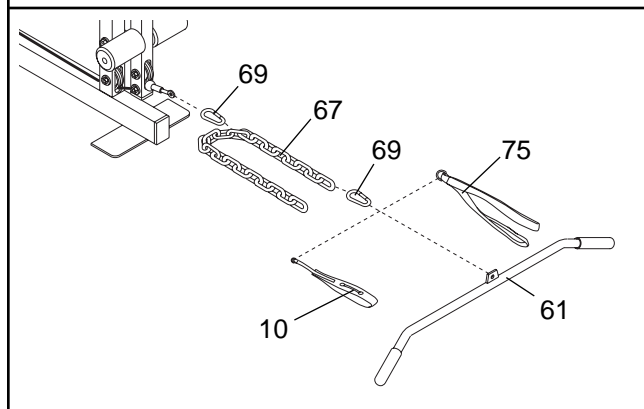

ADJUSTING THE HEIGHT OF THE SEAT

To adjust the height of the Seat (13), loosen the indicated Adjustment Knob (9). Pull out the Knob as far as possible and slide the Seat Upright (37) to the desired position. Release the Knob so that it engages one of the adjustment holes in the Seat Upright. Fully tighten the Knob.

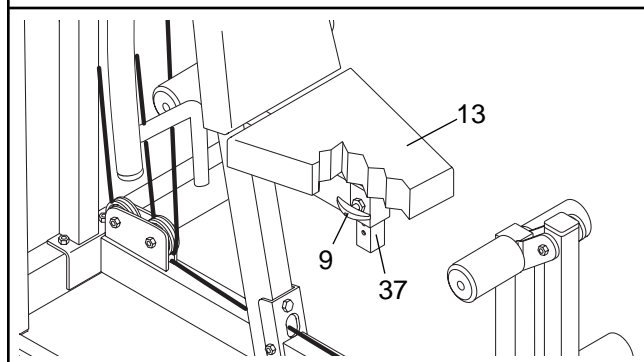

USING THE LEG LEVER LOCK

Some exercises can be performed more comfortably with the Leg Lever (29) locked.

To lock the Leg Lever (29), turn the Leg Lever Lock (11) until it engages the Pad Tube (28) on the Leg Lever.

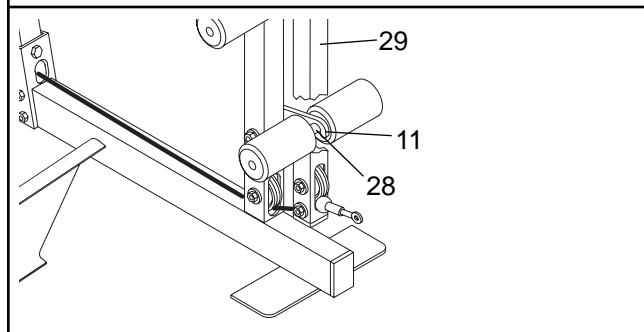

CONVERTING THE PRESS/FLY ARMS

To use the Press/Fly Arms (46, 49) as fly arms, insert the Adjustment Pins (20) into the inner holes in the Press Frame (12) (see inset drawing A).

To use the Press/Fly Arms (46, 49) as press arms, insert the Adjustment Pins (20) into the outer holes in the Press Frame (12) and the tabs on the Press/Fly Arms (see inset drawing B).

Make sure that the Adjustment Pins (20) are fully inserted into the same holes in both sides of the Press Frame (12) before performing any exercises.

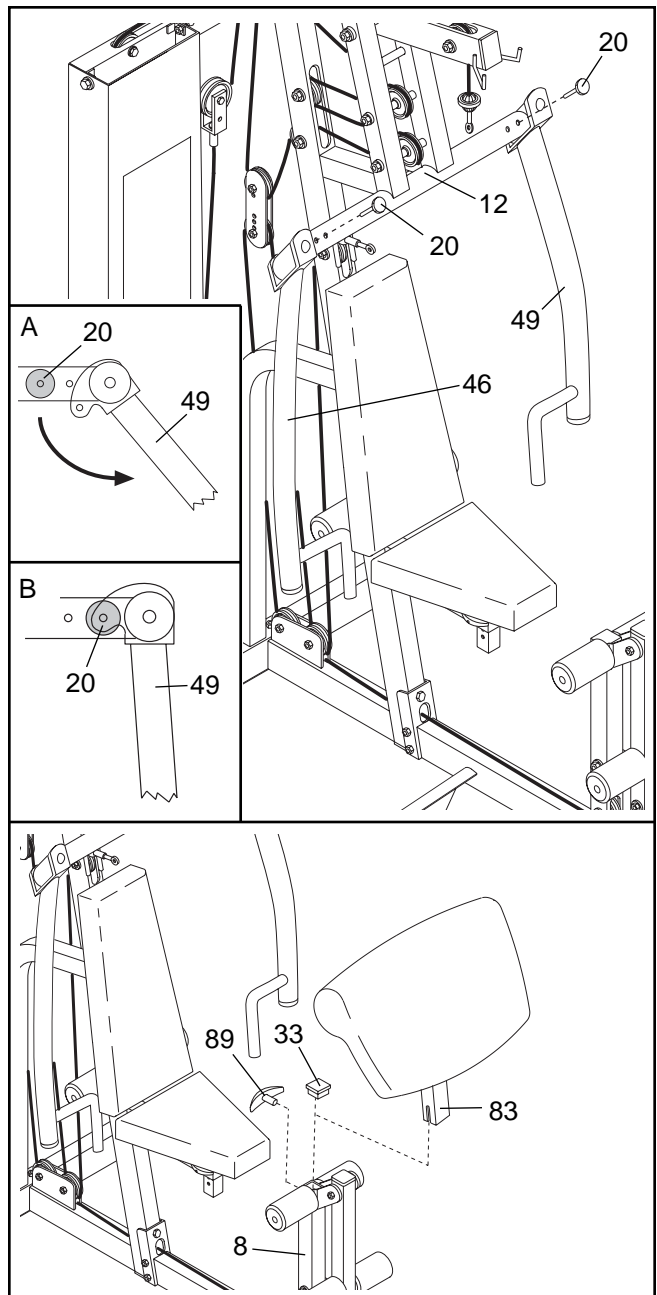

ATTACHING THE CURL PAD

Remove the 2" Square Inner Cap (33) from the front leg on the Base (8). Slide the Curl Post (83) into the front leg and secure it with the Curl Knob (89).

WEIGHT RESISTANCE CHART

This chart shows the approximate weight resistance at each weight station. "Top" refers to the 10 lb. top weight. The other numbers refer to the 10 lb. weight plates. Note: The actual resistance at each station may vary due to differences in individual weight plates as well as friction between the cables, pulleys, and weight guides.

Weight Plates	Press Arm (lbs.)	Low Pulley (lbs.)	High Pulley (lbs.)	AB Pulley (lbs.)	Leg Lever (lbs.)	Leg Press (lbs.)
Top	24	11	13	13	11	28
1	35	22	25	24	22	51
2	46	34	36	35	34	74
3	57	46	48	46	46	97
4	68	57	60	57	57	120
5	79	69	72	68	69	143
6	90	80	83	79	80	167
7	102	92	95	90	92	190
8	113	104	107	102	104	213
9	124	115	119	113	115	236
10	135	127	130	124	127	259
11	146	138	142	135	138	282
12	157	150	154	146	150	305
13	168	162	166	157	162	328
14	179	173	177	168	173	351
15	190	185	189	179	185	374
16	201	196	201	190	196	397
17	213	208	213	201	208	420
18	224	219	224	213	219	443
19	235	231	236	224	231	466

TROUBLESHOOTING AND MAINTENANCE

Make sure all parts are properly tightened each time you use the weight system. Replace any worn parts immediately. The weight system can be cleaned using a damp cloth and mild non-abrasive detergent. Do not use solvents.

TIGHTENING THE CABLES

Woven cable, the type of cable used on the weight system, can stretch slightly when it is first used. If there is slack in the cables before resistance is felt, the cables should be tightened.

To tighten the cables, insert the Weight Pin (39) under the third Weight (26) from the top. Next, loosen the 1/2" Plain Nut (68) securing the bolt at the end of the High Cable (73). Tighten the bolt two turns into the Weight Tube (36) until the cables feel tighter. Tighten the Plain Nut to prevent the bolt from turning.

Note: For clarity, the drawing shows the shroud removed; it is not necessary to remove the shroud.

Additional slack can be removed by moving the indicated 4" Pulley (35) down one set of holes in the Pulley Plates (31). To do this, remove the 3/8" x 1 3/4" Bolt (60) and the 3/8" Nylon Jamnut (63) from the Pulley and the Cable Trap (44). Re-attach the Pulley and Cable Trap to the lower set of holes with the Bolt and Nylon Jamnut. **Make sure that the High Cable (73) is in the groove of the Pulley and that the Cable Trap is turned as shown.** The lower pulley can be moved up to the two higher sets of holes in the same way.

Slack can also be removed by moving the indicated 4" Pulley (35) to the lower hole in the Pulley Bracket (91). To do this, remove the 3/8" x 1 3/4" Bolt (60) and the 3/8" Nylon Jamnut (63) from the Pulley and the Cable Trap (44). Re-attach the Pulley and Cable Trap to the lower set of holes with the Bolt and Nylon Jamnut. **Make sure that the High Cable (73) is in the groove of the Pulley and that the Cable Trap is turned as shown.**

Note: If a cable tends to slip off the pulleys, the cable may have become twisted. Remove the cable and re-install it.

If a cable needs to be replaced, refer to the back cover of this manual.

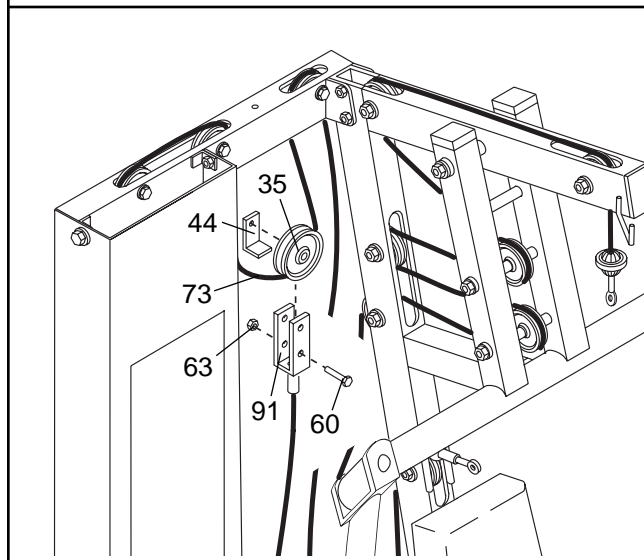
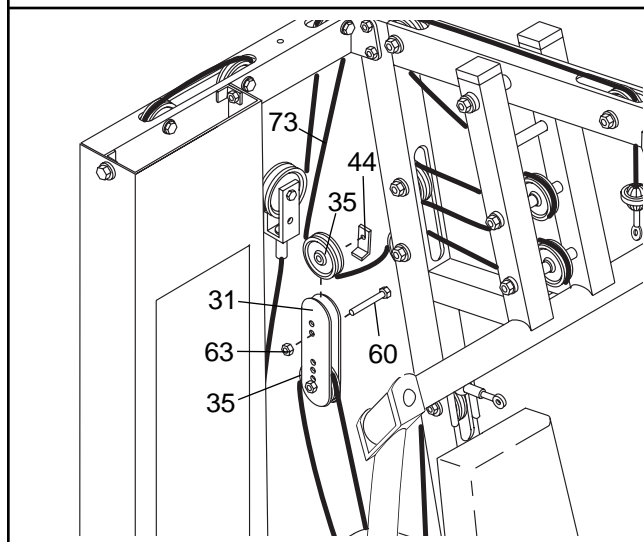
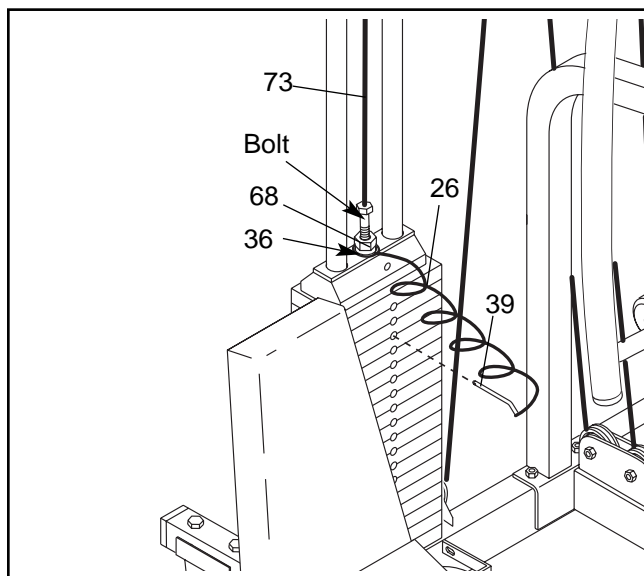

EXERCISE GUIDELINES

THE FOUR BASIC TYPES OF WORKOUTS

Muscle Building

To increase the size and strength of your muscles, push them close to their maximum capacity. Your muscles will continually adapt and grow as you progressively increase the intensity of your exercise. You can adjust the intensity level of an individual exercise in two ways:

- by changing the amount of weight used
- by changing the number of repetitions or sets performed. (A “repetition” is one complete cycle of an exercise, such as one sit-up. A “set” is a series of repetitions.)

The proper amount of weight for each exercise depends upon the individual user. You must gauge your limits and select the amount of weight that is right for you. Begin with 3 sets of 8 repetitions for each exercise you perform. Rest for 3 minutes after each set. When you can complete 3 sets of 12 repetitions without difficulty, increase the amount of weight.

Toning

You can tone your muscles by pushing them to a moderate percentage of their capacity. Select a moderate amount of weight and increase the number of repetitions in each set. Complete as many sets of 15 to 20 repetitions as possible without discomfort. Rest for 1 minute after each set. Work your muscles by completing more sets rather than by using high amounts of weight.

Weight Loss

To lose weight, use a low amount of weight and increase the number of repetitions in each set. Exercise for 20 to 30 minutes, resting for a maximum of 30 seconds between sets.

Cross Training

Cross training is an efficient way to get a complete and well-balanced fitness program. An example of a balanced program is:

- Plan weight training workouts on Monday, Wednesday, and Friday.
- Plan 20 to 30 minutes of aerobic exercise, such as cycling or swimming, on Tuesday and Thursday.
- Rest from both weight training and aerobic exercise for at least one full day each week to give your body time to regenerate.

The combination of weight training and aerobic exercise will reshape and strengthen your body, plus develop your heart and lungs.

PERSONALIZING YOUR EXERCISE PROGRAM

Determining the exact length of time for each workout, as well as the number of repetitions or sets completed, is an individual matter. It is important to avoid overdoing it during the first few months of your exercise program. You should progress at your own pace and be sensitive to your body’s signals. If you experience pain or dizziness at any time while exercising, stop immediately and begin cooling down. Find out what is wrong before continuing. Remember that adequate rest and a proper diet are important factors in any exercise program.

WARMING UP

Begin each workout with 5 to 10 minutes of stretching and light exercise to warm up. Warming up prepares your body for more strenuous exercise by increasing circulation, raising your body temperature and delivering more oxygen to your muscles.

WORKING OUT

Each workout should include 6 to 10 different exercises. Select exercises for every major muscle group, emphasizing areas that you want to develop most. To give balance and variety to your workouts, vary the exercises from session to session.

Schedule your workouts for the time of day when your energy level is the highest. Each workout should be followed by at least one day of rest. Once you find the schedule that is right for you, stick with it.

EXERCISE FORM

Maintaining proper form is an essential part of an effective exercise program. This requires moving through the full range of motion for each exercise, and moving only the appropriate parts of the body. Exercising in an uncontrolled manner will leave you feeling exhausted. On the exercise guide accompanying this manual you will find photographs showing the correct form for several exercises, and a list of the muscles affected. Refer to the muscle chart on page 27 to find the names of the muscles.

The repetitions in each set should be performed smoothly and without pausing. The exertion stage of each repetition should last about half as long as the return stage. Proper breathing is important. Exhale during the exertion stage of each repetition and inhale during the return stroke. Never hold your breath.

Rest for a short period of time after each set. The ideal resting periods are:

- Rest for three minutes after each set for a muscle building workout.
- Rest for one minute after each set for a toning workout.
- Rest for 30 seconds after each set for a weight loss workout.

Plan to spend the first couple of weeks familiarizing yourself with the equipment and learning the proper form for each exercise.

COOLING DOWN

End each workout with 5 to 10 minutes of stretching. Include stretches for both your arms and legs. Move

slowly as you stretch and do not bounce. Ease into each stretch gradually and go only as far as you can without strain. Stretching at the end of each workout is an effective way to increase flexibility.

STAYING MOTIVATED

For motivation, keep a record of each workout. List the date, the exercises performed, the weight used, and the numbers of sets and repetitions completed. Record your weight and key body measurements at the end of every month. Remember, the key to achieving the greatest results is to make exercise a regular and enjoyable part of your everyday life.

MUSCLE CHART

- A. Sternomastoid (neck)
- B. Pectoralis Major (chest)
- C. Biceps (front of arm)
- D. Obliques (waist)
- E. Brachioradials (forearm)
- F. Hip Flexors (upper thigh)
- G. Abductor (outer thigh)
- H. Quadriceps (front of thigh)
- I. Sartorius (front of thigh)
- J. Tibialis Anterior (front of calf)
- K. Soleus (front of calf)
- L. Rectus Abdominus (stomach)
- M. Adductor (inner thigh)
- N. Trapezius (upper back)
- O. Rhomboideus (upper back)
- P. Deltoid (shoulder)
- Q. Triceps (back of arm)
- R. Latissimus Dorsi (mid back)
- S. Spinae Erectors (lower back)
- T. Gluteus Medius (hip)
- U. Gluteus Maximus (buttocks)
- V. Hamstring (back of leg)
- W. Gastrocnemius (back of calf)

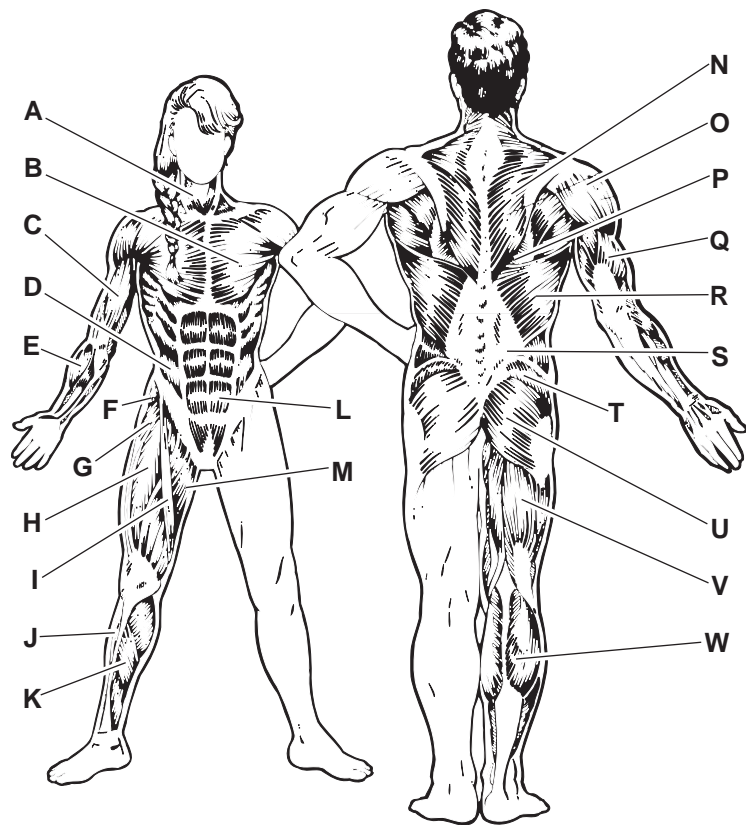

PART IDENTIFICATION CHART—Model No. PFSY69520 R0103A

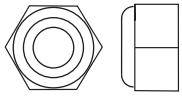

1/4" Nylon Locknut (25)

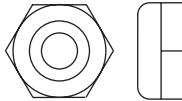

5/16" Nylon Jamnut (79)

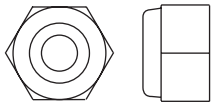

5/16" Nylon Locknut (81)

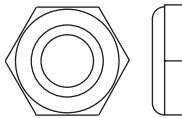

3/8" Nylon Jamnut (63)

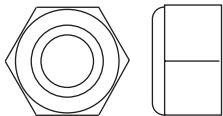

3/8" Nylon Locknut (50)

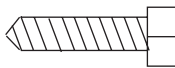

#8 x 3/4" Screw (32)

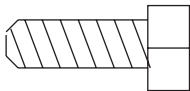

1/4" x 3/4" Bolt (17)

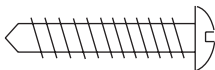

#10 x 1" Tap Screw (7)

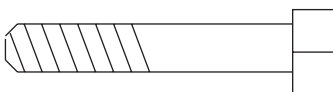

1/4" x 1 1/2" Bolt (101)

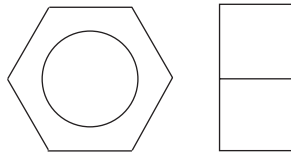

1/2" Plain Nut (68)

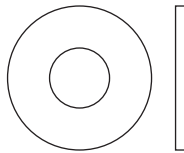

1/4" Washer (71)

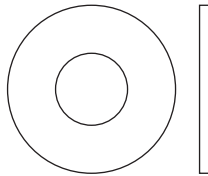

5/16" Washer (80)

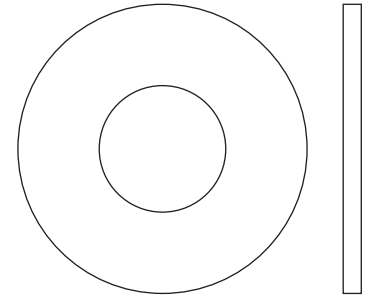

1 1/2" Washer (40)

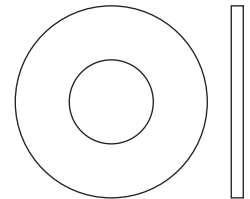

3/8" USS Washer (104)

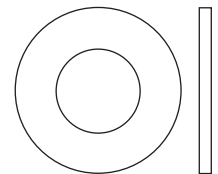

3/8" Washer (55)

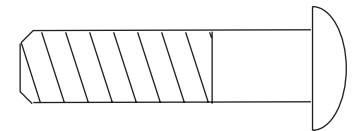

3/8" x 1 1/2" Button Cap Screw (2)

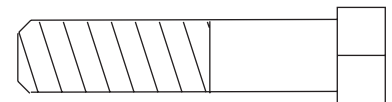

3/8" x 1 3/4" Bolt (60)

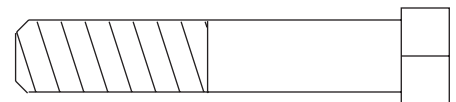

3/8" x 2" Bolt (62)

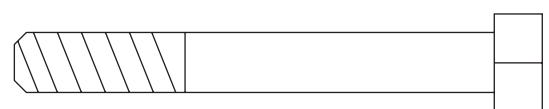

5/16" x 2 1/2" Bolt (96)

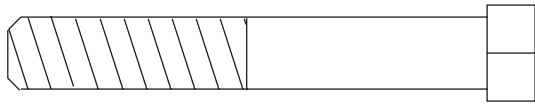

3/8" x 2 1/2" Bolt (54)

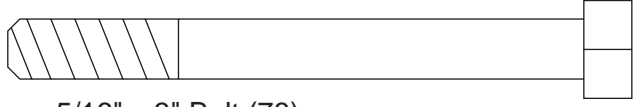

5/16" x 3" Bolt (78)



3/8" x 3" Bolt (45)

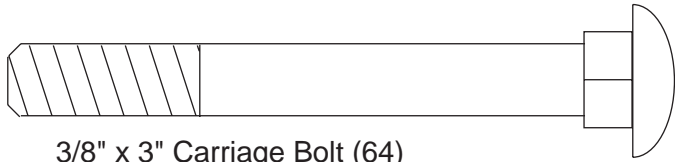

3/8" x 3" Carriage Bolt (64)



3/8" x 3 1/4" Bolt (87)

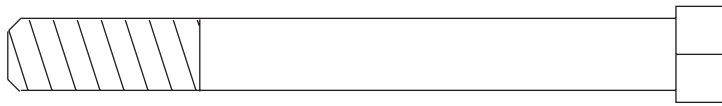

3/8" x 3 1/2" Bolt (22)

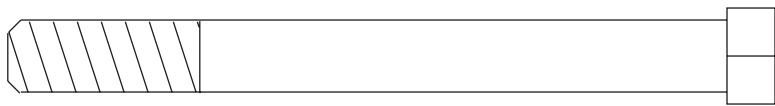

3/8" x 3 3/4" Bolt (92)



1/4" x 3 3/4" Carriage Bolt (43)

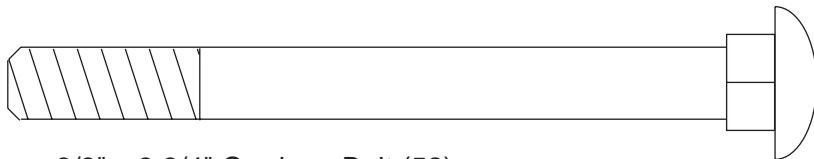

3/8" x 3 3/4" Carriage Bolt (52)

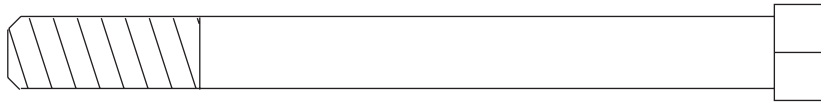

3/8" x 4" Bolt (65)

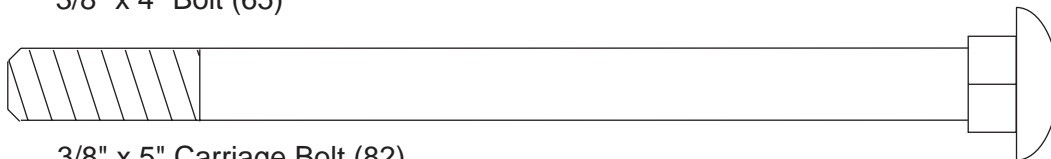

3/8" x 5" Carriage Bolt (82)

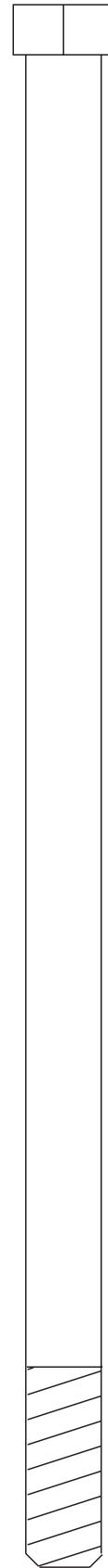

3/8" x 8 1/2" Bolt (59)

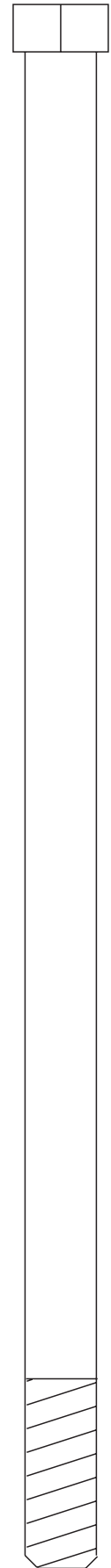

3/8" x 9" Bolt (51)



1/2" x 1 3/4" Bushing (94)

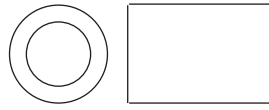

1/2" x 3/4" Long Bushing (93)

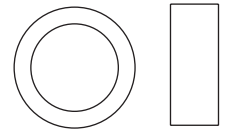

5/8" x 1/4" Bushing (90)

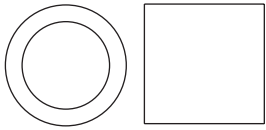

5/8" x 1/2" Bushing (42)

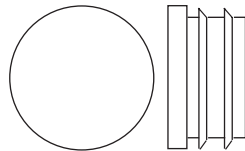

3/4" Round Inner Cap (34)

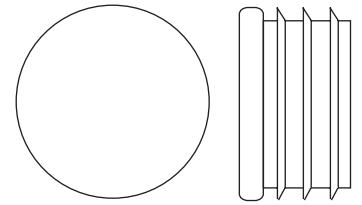

1" Round Inner Cap (103)

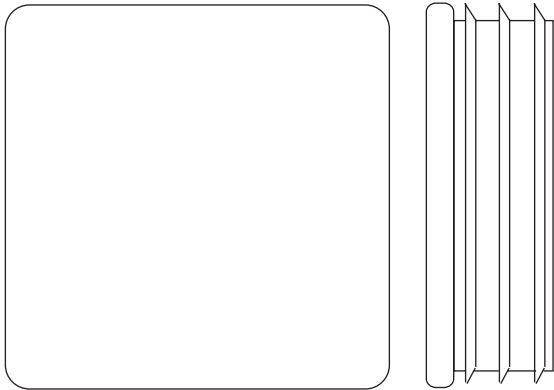

2" Square Inner Cap (33)

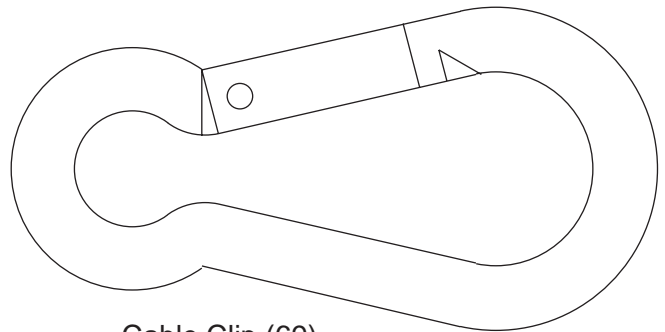

Cable Clip (69)

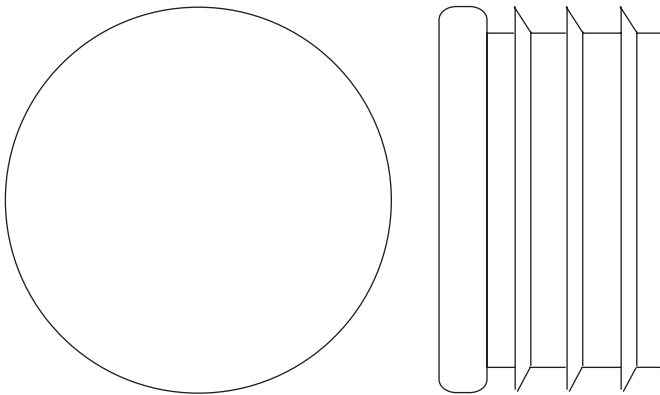

2" Round Inner Cap (57)

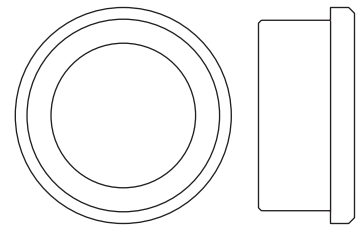

3/4" x 1/2" Flange Bushing (18)

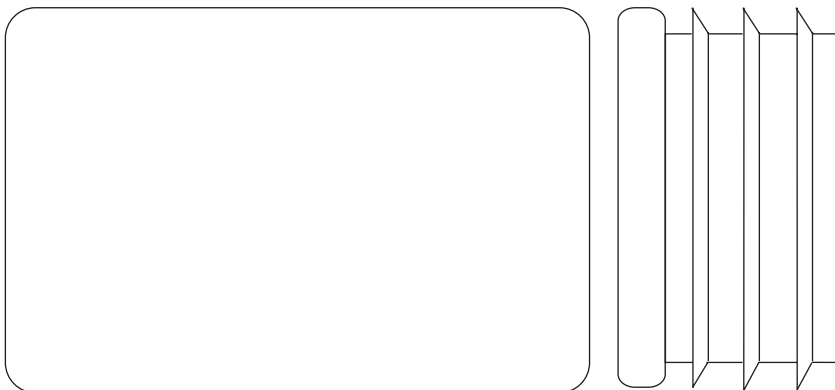

2" x 3" Inner Cap (24)

PART LIST—Model No. PFSY69520

R0103A

Key No.	Qty.	Description	Key No.	Qty.	Description
1	1	Top Frame	54	11	3/8" x 2 1/2" Bolt
2	1	3/8" x 1 1/2" Button Cap Screw	55	35	3/8" Washer
3	1	Main Upright	56	1	Shroud
4	1	Flat Plate	57	2	2" Round Inner Cap
5	1	Stabilizer	58	2	Arm Grip
6	1	Leg Lever Bumper	59	2	3/8" x 8 1/2" Bolt
7	1	#10 x 1" Tap Screw	60	5	3/8" x 1 3/4" Bolt
8	1	Base	61	1	Lat Bar
9	2	Adjustment Knob	62	3	3/8" x 2" Bolt
10	1	Ankle Strap	63	22	3/8" Nylon Jamnut
11	1	Leg Lever Lock	64	6	3/8" x 3" Carriage Bolt
12	1	Press Frame	65	1	3/8" x 4" Bolt
13	2	Seat	66	1	Weight Cover
14	2	Plastic Sleeve	67	1	Chain
15	2	Handgrip	68	1	1/2" Plain Nut
16	1	Top Weight	69	3	Cable Clip
17	22	1/4" x 3/4" Bolt	70	1	Leg Press Backrest
18	8	3/4" x 1/2" Flange Bushing	71	5	1/4" Washer
19	2	Weight Bumper	72	1	Low Cable
20	2	Adjustment Pin	73	1	High Cable
21	1	Curly Pad	74	1	Sliding Seat Frame
22	1	3/8" x 3 1/2" Bolt	75	1	Ab Strap
23	2	Weight Guide	76	1	Leg Press Cable
24	5	2" x 3" Inner Cap	77	38	Weight Insert
25	9	1/4" Nylon Locknut	78	3	5/16" x 3" Bolt
26	19	Weight	79	1	5/16" Nylon Jamnut
27	2	Backrest Plate	80	5	5/16" Washer
28	3	Pad Tube	81	3	5/16" Nylon Locknut
29	1	Leg Lever	82	1	3/8" x 5" Carriage Bolt
30	6	Foam Pad	83	1	Curly Post
31	2	Pulley Plate	84	1	Leg Press Base
32	2	#8 x 3/4" Screw	85	1	Leg Press Plate
33	10	2" Square Inner Cap	86	2	Handgrip
34	6	3/4" Round Inner Cap	87	6	3/8" x 3 1/4" Bolt
35	21	4" Pulley	88	1	Seat Frame Channel
36	1	Weight Tube	89	1	Curly Knob
37	1	Seat Upright	90	1	5/8" x 1/4" Bushing
38	2	Tinnerman Clip	91	1	Pulley Bracket
39	1	Weight Pin	92	2	3/8" x 3 3/4" Bolt
40	1	1 1/2" Washer	93	1	1/2" x 3/4" Long Bushing
41	1	Backrest	94	1	1/2" x 1 3/4" Bushing
42	22	5/8" x 1/2" Bushing	95	2	Handle
43	2	1/4" x 3 3/4" Carriage Bolt	96	1	5/16" x 2 1/2" Bolt
44	7	Cable Trap	97	1	Rear Leg Press Upright
45	3	3/8" x 3" Bolt	98	1	Forward Leg Press Upright
46	1	Right Press/Fly Arm	99	1	Angle Cap
47	1	Weight Tube Bumper	100	2	Leg Press Attachment
48	4	Large Bushing	101	4	1/4" x 1 1/2" Bolt
49	1	Left Press/Fly Arm	102	1	Chart Decal
50	23	3/8" Nylon Locknut	103	2	1" Round Inner Cap
51	1	3/8" x 9" Bolt	104	2	3/8" USS Washer
52	3	3/8" x 3 3/4" Carriage Bolt	#	1	User's Manual
53	2	Plastic Sleeve Bushing			

Note: “#” indicates a non-illustrated part. Specifications are subject to change without notice. See the back cover of the user’s manual for information about ordering replacement parts.

EXPLODED DRAWING—Model No. PFSY69520

R0103A

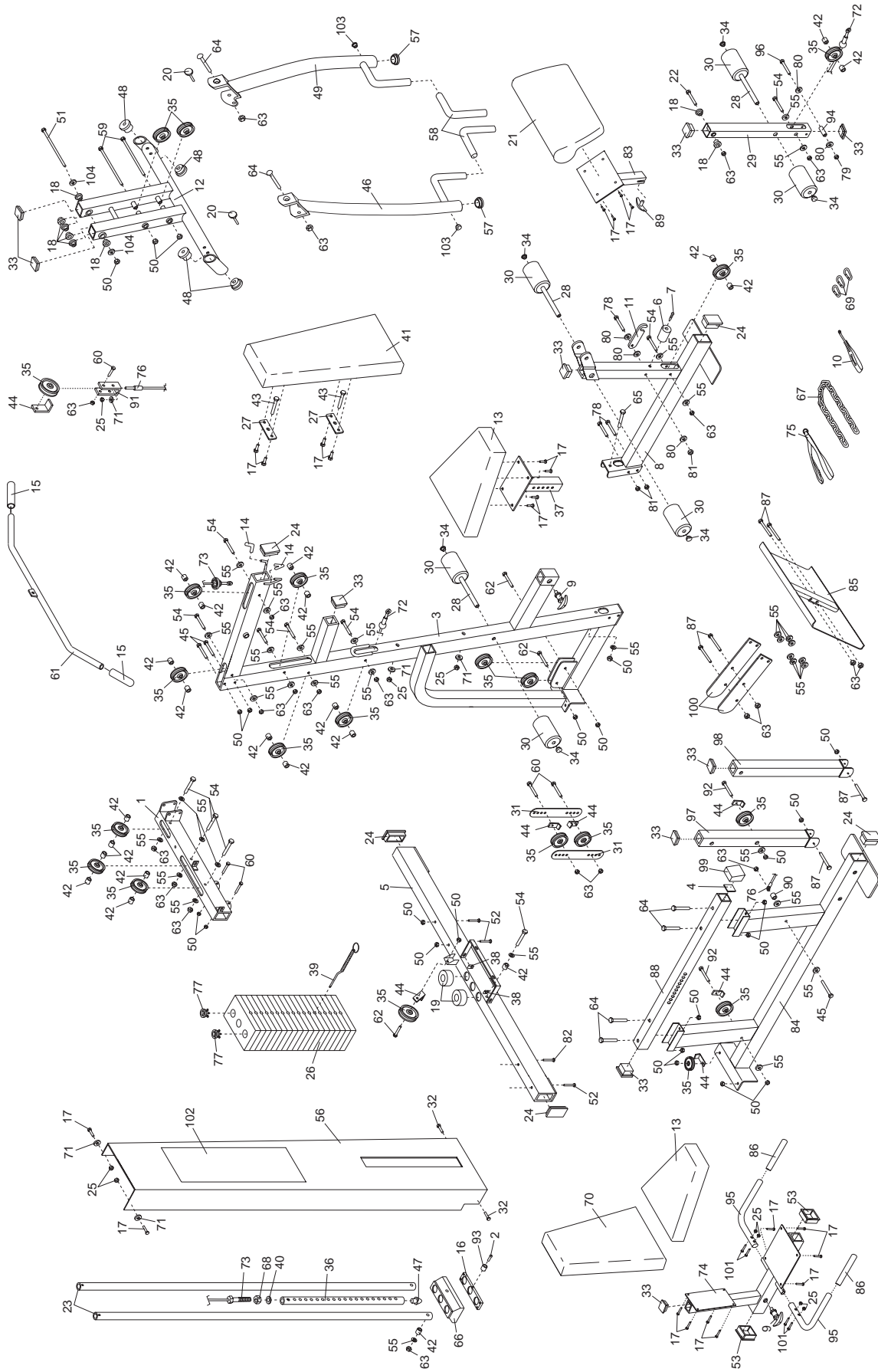

ORDERING REPLACEMENT PARTS

To order replacement parts, simply call our Customer Service Department toll-free at 1-800-999-3756, Monday through Friday, 6 a.m. until 6 p.m. Mountain Time (excluding holidays). To help us assist you, please be prepared to give the following information:

1. The MODEL NUMBER of the product (PFSY69520)
2. The NAME of the product (PROFORM® 650 weight system)
3. The SERIAL NUMBER of the product (see the front cover of this manual)
4. The KEY NUMBER and DESCRIPTION of the part(s) (see the PART LIST and EXPLODED DRAWING in the center of this manual).

LIMITED WARRANTY

ICON Health & Fitness, Inc. (ICON), warrants this product to be free from defects in workmanship and material, under normal use and service conditions, for a period of ninety (90) days from the date of purchase. This warranty extends only to the original purchaser. ICON's obligation under this warranty is limited to replacing or repairing, at ICON's option, the product through one of its authorized service centers. All repairs for which warranty claims are made must be pre-authorized by ICON. This warranty does not extend to any product or damage to a product caused by or attributable to freight damage, abuse, misuse, improper or abnormal usage or repairs not provided by an ICON authorized service center; products used for commercial or rental purposes; or products used as store display models. No other warranty beyond that specifically set forth above is authorized by ICON.

ICON is not responsible or liable for indirect, special or consequential damages arising out of or in connection with the use or performance of the product or damages with respect to any economic loss, loss of property, loss of revenues or profits, loss of enjoyment or use, costs of removal or installation or other consequential damages of whatsoever nature. Some states do not allow the exclusion or limitation of incidental or consequential damages. Accordingly, the above limitation may not apply to you.

The warranty extended hereunder is in lieu of any and all other warranties and any implied warranties of merchantability or fitness for a particular purpose is limited in its scope and duration to the terms set forth herein. Some states do not allow limitations on how long an implied warranty lasts. Accordingly, the above limitation may not apply to you.

This warranty gives you specific legal rights. You may also have other rights which vary from state to state.

ICON HEALTH & FITNESS, INC., 1500 S. 1000 W., LOGAN, UT 84321-9813

Free Manuals Download Website

<http://myh66.com>

<http://usermanuals.us>

<http://www.somanuals.com>

<http://www.4manuals.cc>

<http://www.manual-lib.com>

<http://www.404manual.com>

<http://www.luxmanual.com>

<http://aubethermostatmanual.com>

Golf course search by state

<http://golfingnear.com>

Email search by domain

<http://emailbydomain.com>

Auto manuals search

<http://auto.somanuals.com>

TV manuals search

<http://tv.somanuals.com>