

PRO-FORM[®]

TRAILRUNNER 4.0

www.proform.com

Model No. PFTL16010.0

Serial No. _____

Write the serial number in the space above for reference.

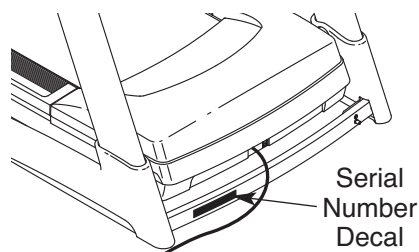

USER'S MANUAL

QUESTIONS?

If you have questions, or if parts are damaged or missing, **DO NOT CONTACT THE STORE**; please contact Customer Care.

IMPORTANT: Please register this product (see the limited warranty on the back cover of this manual) before contacting Customer Care.

CALL TOLL-FREE:

1-888-533-1333

Mon.–Fri. 6 a.m.–6 p.m. MT

Sat. 8 a.m.–4 p.m. MT

ON THE WEB:

www.proformservice.com

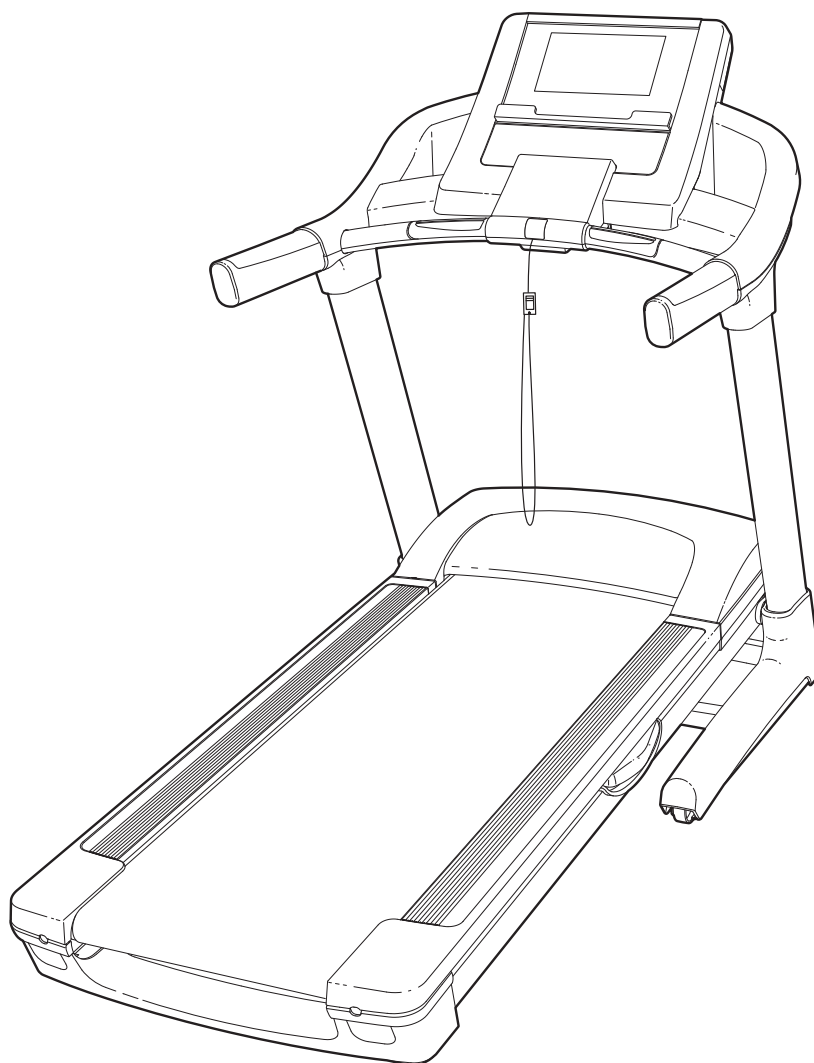

CAUTION

Read all precautions and instructions in this manual before using this equipment. Save this manual for future reference.



TABLE OF CONTENTS

WARNING DECAL PLACEMENT2

IMPORTANT PRECAUTIONS3

BEFORE YOU BEGIN5

ASSEMBLY6

OPERATION AND ADJUSTMENT12

HOW TO FOLD AND MOVE THE TREADMILL27

TROUBLESHOOTING28

EXERCISE GUIDELINES31

PART LIST33

EXPLODED DRAWING35

ORDERING REPLACEMENT PARTSBack Cover

LIMITED WARRANTYBack Cover

WARNING DECAL PLACEMENT

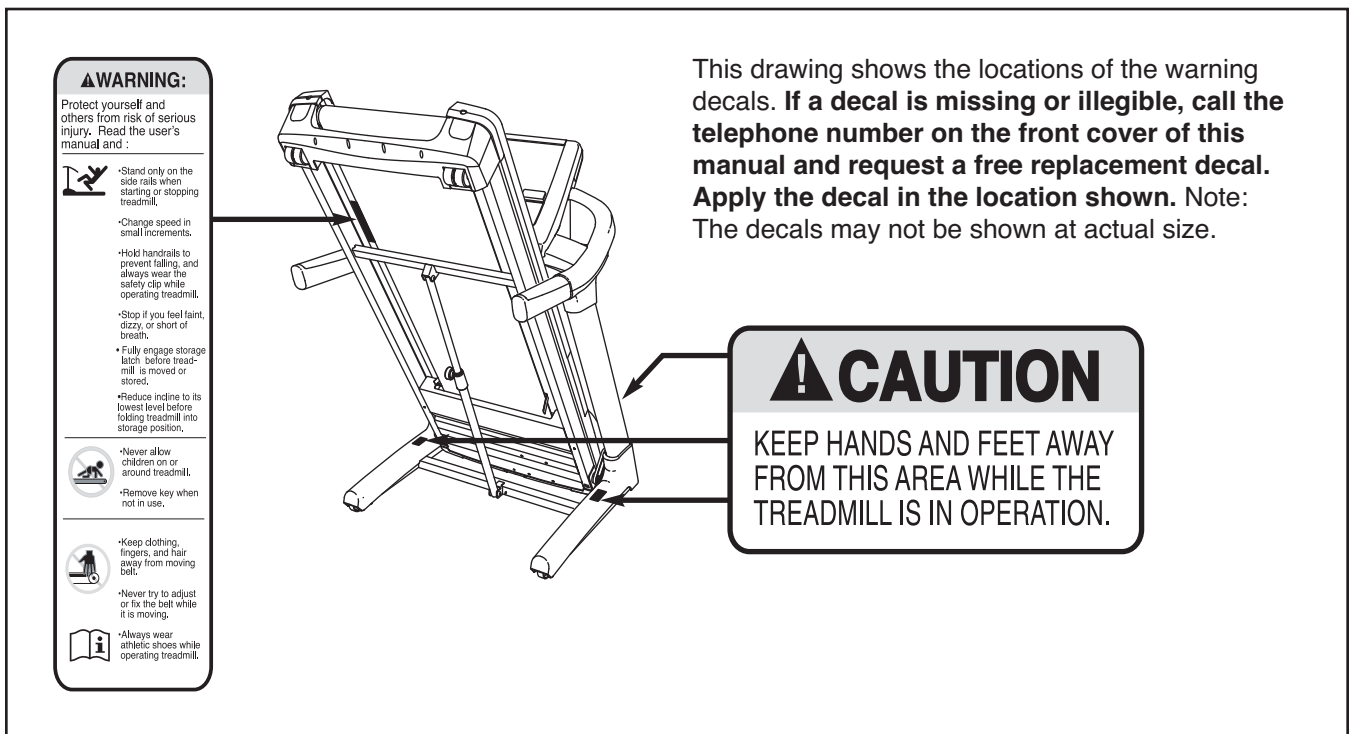

IMPORTANT PRECAUTIONS

⚠️ WARNING: To reduce the risk of serious injury, read all important precautions and instructions in this manual and all warnings on your treadmill before using your treadmill. ICON assumes no responsibility for personal injury or property damage sustained by or through the use of this product.

1. Before beginning this or any exercise program, consult your physician. This is especially important for persons over age 35 or persons with pre-existing health problems.
2. It is the responsibility of the owner to ensure that all users of this treadmill are adequately informed of all warnings and precautions.
3. Use the treadmill only as described.
4. Keep the treadmill indoors, away from moisture and dust. Do not put the treadmill in a garage or covered patio, or near water.
5. Place the treadmill on a level surface, with at least 8 ft. (2.4 m) of clearance behind it and 2 ft. (0.6 m) on each side. Do not place the treadmill on any surface that blocks air openings. To protect the floor or carpet from damage, place a mat under the treadmill.
6. Do not operate the treadmill where aerosol products are used or where oxygen is being administered.
7. Keep children under age 12 and pets away from the treadmill at all times.
8. The treadmill should be used only by persons weighing 350 lbs. (159 kg) or less.
9. Never allow more than one person on the treadmill at a time.
10. Wear appropriate exercise clothes when using the treadmill. Do not wear loose clothes that could become caught in the treadmill. Athletic support clothes are recommended for both men and women. *Always wear athletic shoes. Never use the treadmill with bare feet, wearing only stockings, or in sandals.*
11. When connecting the power cord (see page 12), plug the power cord into a surge suppressor (not included) and plug the surge suppressor into a grounded circuit capable of carrying 15 or more amps. No other appliance should be on the same circuit. Do not use an extension cord.
12. Use only a single-outlet surge suppressor that meets all of the specifications described on page 12. To purchase a surge suppressor, see your local PROFORM dealer or call the telephone number on the front cover of this manual and order part number 146148, or see your local electronics store.
13. Failure to use a properly functioning surge suppressor could result in damage to the control system of the treadmill. If the control system is damaged, the walking belt may slow, accelerate, or stop unexpectedly, which may result in a fall and serious injury.
14. Keep the power cord and the surge suppressor away from heated surfaces.
15. Never move the walking belt while the power is turned off. Do not operate the treadmill if the power cord or plug is damaged, or if the treadmill is not working properly. (See TROUBLESHOOTING on page 28 if the treadmill is not working properly.)
16. Read, understand, and test the emergency stop procedure before using the treadmill (see HOW TO TURN ON THE POWER on page 14).
17. Never start the treadmill while you are standing on the walking belt. Always hold the handrails while using the treadmill.

18. The treadmill is capable of high speeds. Adjust the speed in small increments to avoid sudden jumps in speed.
19. The pulse sensor is not a medical device. Various factors, including the user's movement, may affect the accuracy of heart rate readings. The pulse sensor is intended only as an exercise aid in determining heart rate trends in general.
20. Never leave the treadmill unattended while it is running. Always remove the key, unplug the power cord, and press the power switch into the off position when the treadmill is not in use. (See the drawing on page 5 for the location of the power switch.)
21. Do not attempt to raise, lower, or move the treadmill until it is properly assembled. (See ASSEMBLY on page 6, and HOW TO FOLD AND MOVE THE TREADMILL on page 27.) You must be able to safely lift 45 lbs. (20 kg) to raise, lower, or move the treadmill.
22. Do not change the incline of the treadmill by placing objects under the treadmill.
23. Inspect and properly tighten all parts of the treadmill regularly.
24. Never insert or drop any object into any opening on the treadmill.
25. **DANGER:** Always unplug the power cord immediately after use, before cleaning the treadmill, and before performing the maintenance and adjustment procedures described in this manual. Never remove the motor hood unless instructed to do so by an authorized service representative. Servicing other than the procedures in this manual should be performed by an authorized service representative only.
26. The treadmill is intended for in-home use only. Do not use the treadmill in any commercial, rental, or institutional setting.
27. Over exercising may result in serious injury or death. If you feel faint or if you experience pain while exercising, stop immediately and cool down.

SAVE THESE INSTRUCTIONS

BEFORE YOU BEGIN

Thank you for selecting the revolutionary PROFORM® TRAILRUNNER 4.0 treadmill. The TRAILRUNNER 4.0 treadmill offers an impressive selection of features designed to make your workouts at home more enjoyable and effective. And when you're not exercising, the unique treadmill can be folded up, requiring less than half the floor space of other treadmills.

For your benefit, read this manual carefully before using the treadmill. If you have questions after read-

ing this manual, please see the front cover of this manual. To help us assist you, note the product model number and serial number before contacting us. The model number and the location of the serial number decal are shown on the front cover of this manual.

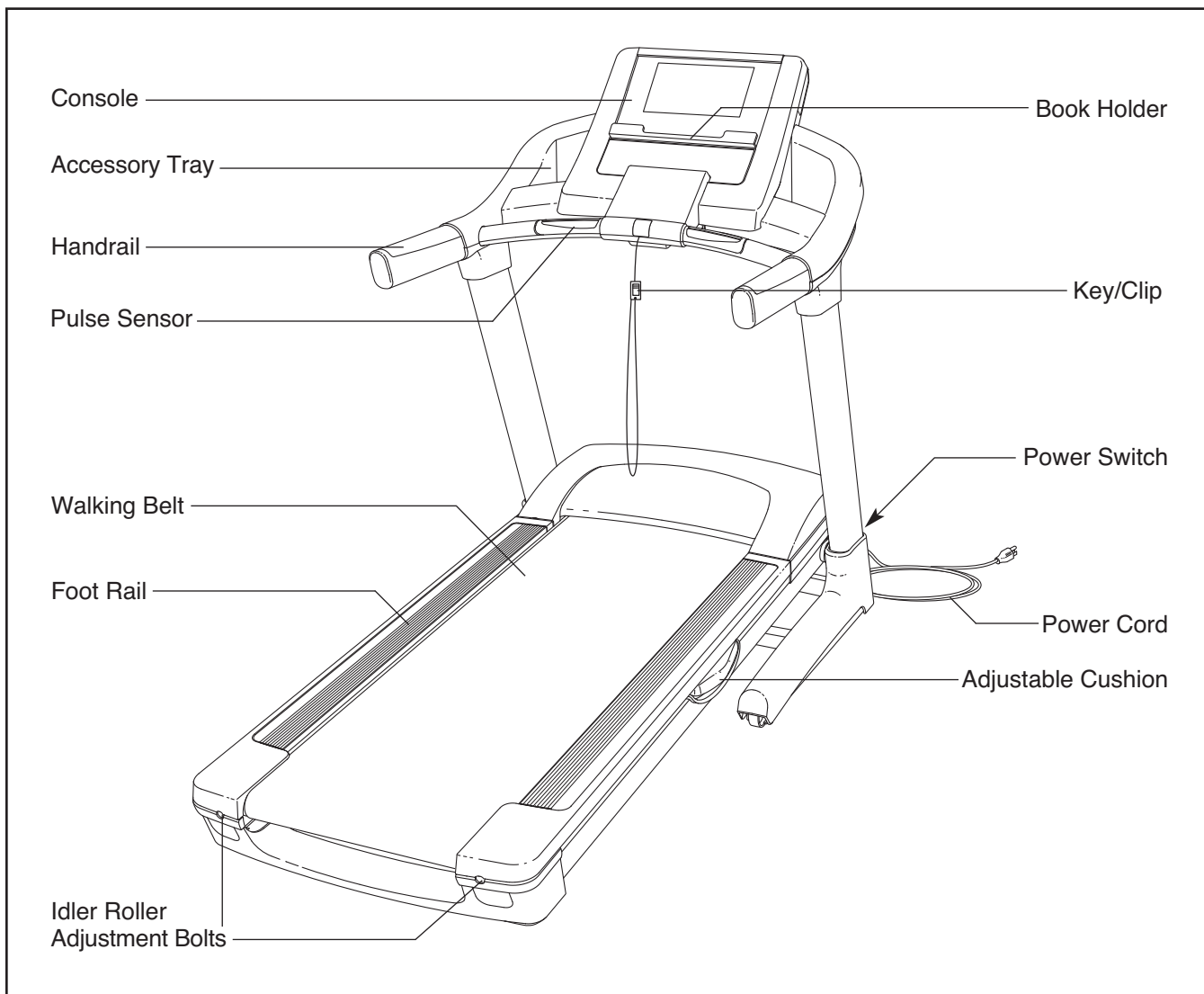

Before reading further, please look at the drawing below and familiarize yourself with the labeled parts.



ASSEMBLY

To hire an authorized service technician to assemble the treadmill, call 1-800-445-2480.

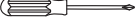
Assembly requires two persons. Set the treadmill in a cleared area and remove all packing materials. **Do not dispose of the packing materials until assembly is completed.** Note: The underside of the treadmill walking belt is coated with high-performance lubricant. During shipping, some lubricant may be transferred to the top of the walking belt or the shipping carton. This is normal and does not affect performance. If there is lubricant on top of the walking belt, simply wipe off the lubricant with a soft cloth and a mild, non-abrasive cleaner.

Assembly requires the included hex keys  and your own Phillips screwdriver  and adjustable wrench .

Use the drawings below to identify the assembly hardware. The number in parentheses below each drawing is the key number of the part, from the PART LIST near the end of this manual. The number after the parentheses is the quantity needed for assembly. **Note: Some small parts may have been preassembled. To avoid damaging parts, do not use power tools for assembly.**

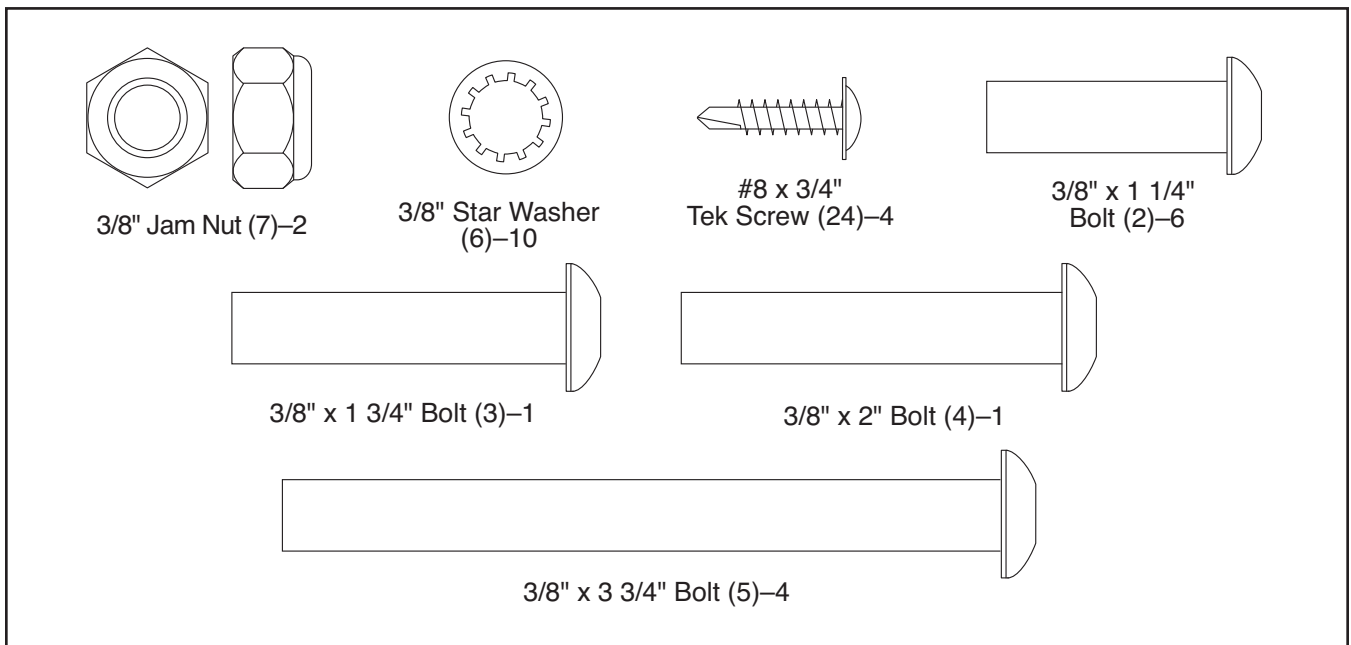

1. **Make sure that the power cord is unplugged.**

With the help of a second person, raise the front of the treadmill and insert the crossbar on the Base (103) into the cutout in the cardboard stand as shown. **Have the second person hold the treadmill until assembly step 3 to prevent it from moving forward or backward.**

⚠ WARNING: Serious injury may occur if the treadmill moves forward or backward and falls off the cardboard stand. A second person must hold the treadmill until assembly step 3 to prevent the treadmill from moving, tipping, or falling.

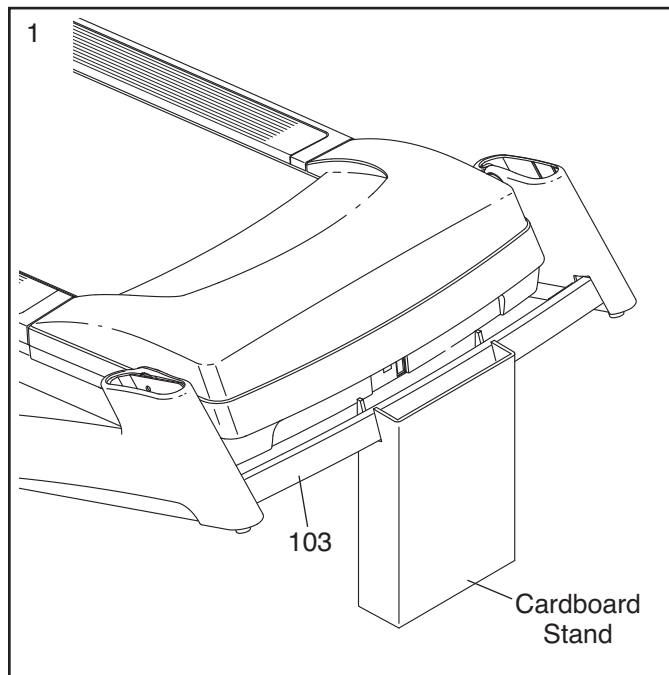

2. Identify the Right Upright (92), which is marked with a "Right" sticker.

Have a second person hold the Right Upright (92) near the Right Base Cover (102). **See the inset drawing.** Tie the wire tie in the lower end of the Right Upright securely around the end of the Upright Wire (93). Then, pull the other end of the wire tie in the top of the Right Upright until the Upright Wire is routed through the Right Upright.

Gently pull up on the Upright Wire (93) as you set the Right Upright (92) on the Base (103) inside the Right Base Cover (102). **Be careful not to pinch the Upright Wire.**

Attach the Right Upright (92) to the Base (103) with two 3/8" x 3 3/4" Bolts (5) and two 3/8" Star Washers (6). Note: It may be necessary to tip the top of the Right Upright forward slightly as you thread the Bolts into it. **Do not tighten the Bolts yet.**

Attach the Left Upright (91) in the same way.
Note: There are no wires on the left side.

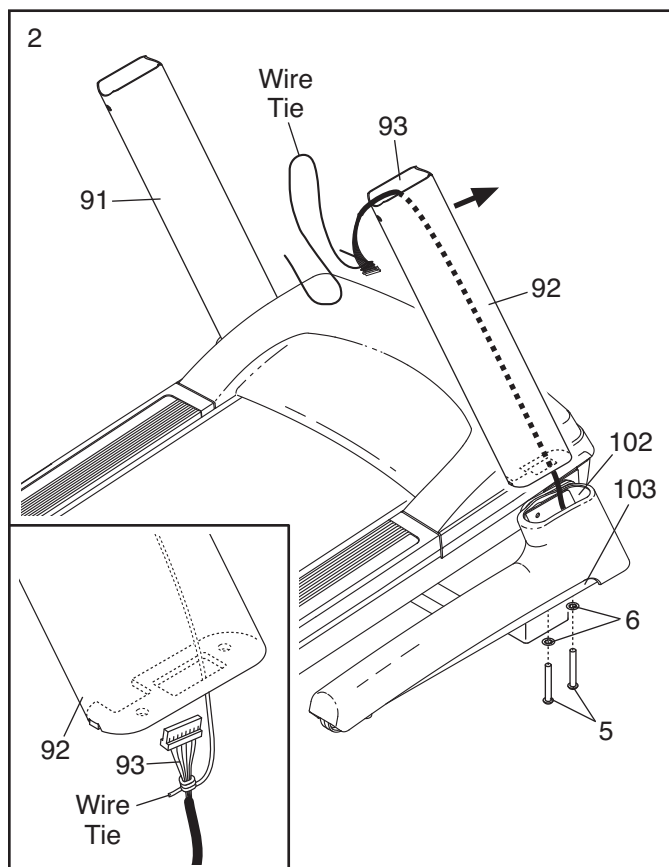

3. With the help of a second person, lower the treadmill off the cardboard stand. The stand will be used again in assembly step 9.

Identify the Right Upright Sleeve (90) and the Left Upright Sleeve (89), which are labeled "Right" and "Left."

Slide the Right Upright Sleeve (90) onto the Right Upright (92), and slide the Left Upright Sleeve (89) onto the Left Upright (91).

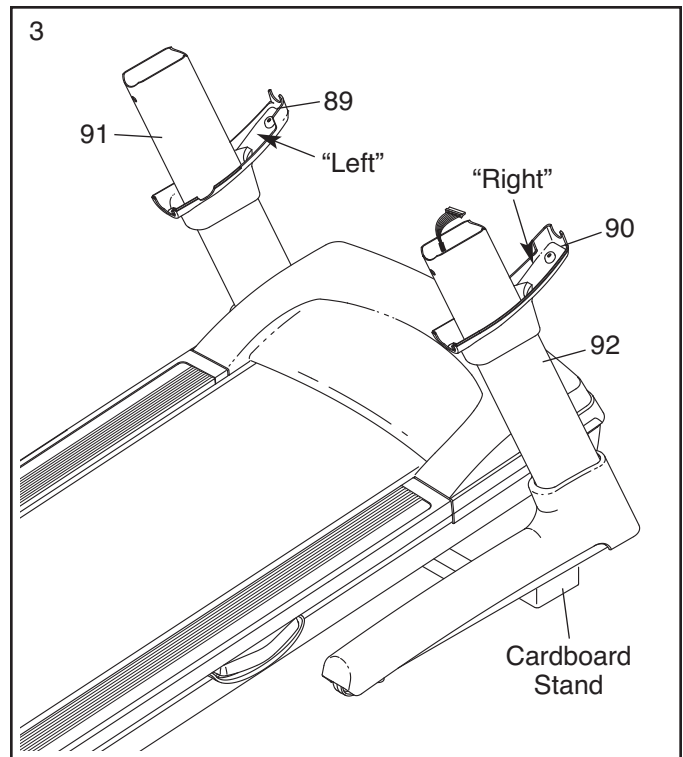

4. Have a second person hold the console assembly near the Uprights (91, 92).

Connect the Upright Wire (93) to the Console Wire (88). **See the inset drawing. The connectors should slide together easily and snap into place.** If they do not, turn one connector and try again. **IF YOU DO NOT CONNECT THE CONNECTORS PROPERLY, THE CONSOLE MAY BECOME DAMAGED WHEN YOU TURN ON THE POWER.** Remove the wire tie from the Upright Wire. Insert the connectors down into the Right Upright (92).

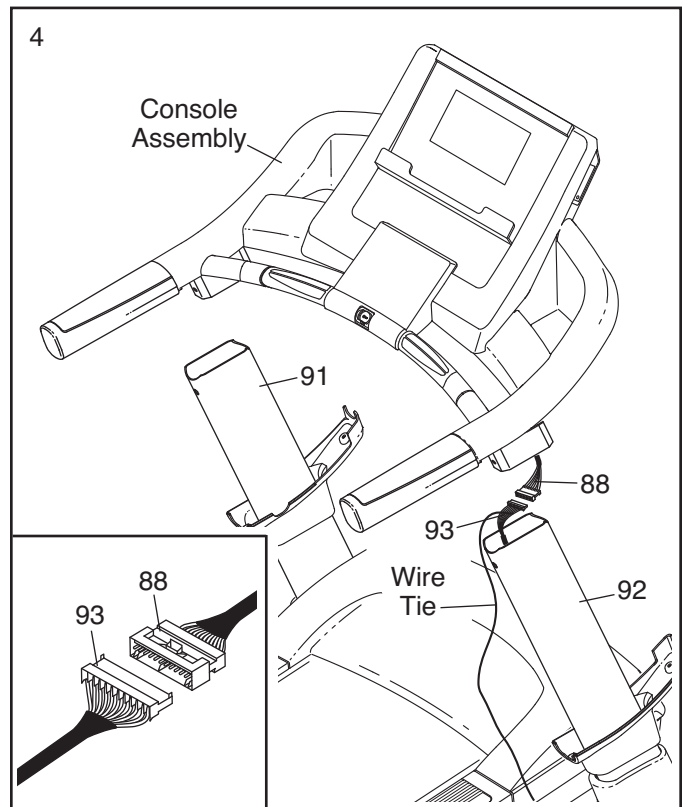

5. Insert the brackets on the Handrail (110) into the Uprights (91, 92). **Make sure that no wires are pinched.**

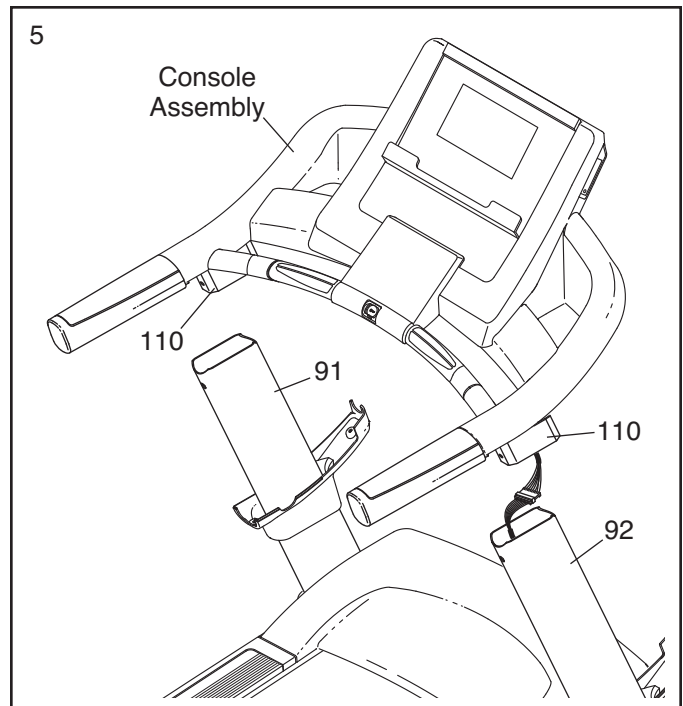

6. Partially tighten three 3/8" x 1 1/4" Bolts (2) with three 3/8" Star Washers (6) into the Right Upright (92); **do not fully tighten the Bolts yet.**

Repeat this step with the Left Upright (91).

Firmly tighten all six 3/8" x 1 1/4" Bolts (2).

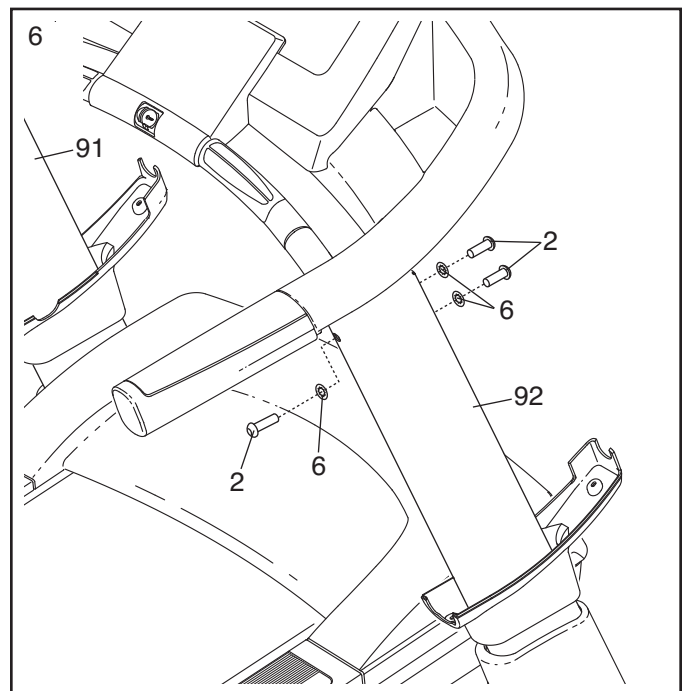

- Slide the Right Upright Sleeve (90) up against the console assembly. Attach the Right Upright Sleeve with two #8 x 3/4" Tek Screws (24).

Attach the Left Upright Sleeve (not shown) to the console assembly in the same way.

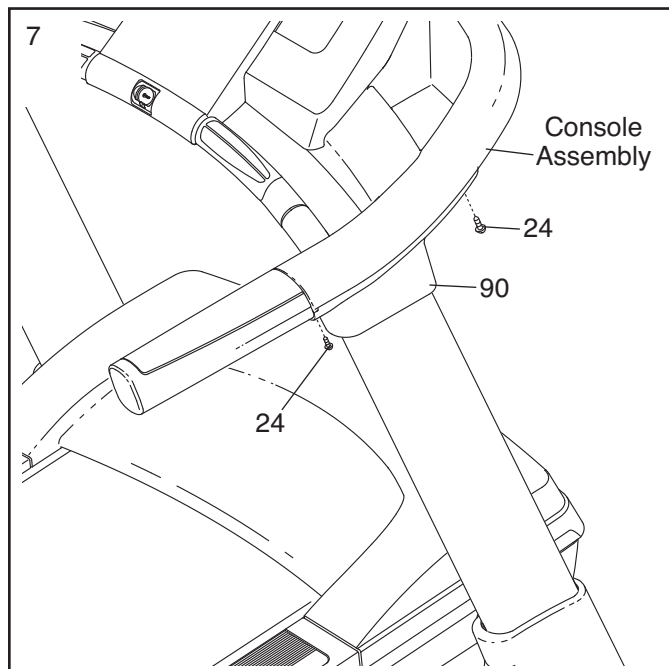

- Raise the Frame (67) to the position shown. **Have a second person hold the Frame until this step is completed.**

Orient the Storage Latch (87) so that the large barrel and the latch knob are in the positions shown.

Remove the tie from the upper end of the Storage Latch (87). Attach the upper end of the Storage Latch to the bracket on the Frame (67) with a 3/8" x 1 3/4" Bolt (3) and a 3/8" Jam Nut (7).

Remove the tie from the lower end of the Storage Latch (87). Keep the holes in the latch cap aligned with the holes in the Storage Latch. **Make sure to keep the latch cap inside the Storage Latch.** Attach the Storage Latch to the bracket on the Base (103) with a 3/8" x 2" Bolt (4) and a 3/8" Jam Nut (7). Note: It may be necessary to move the Frame (67) back and forth slightly to align the Storage Latch with the bracket.

Lower the Frame (67) (see HOW TO LOWER THE TREADMILL FOR USE on page 27).

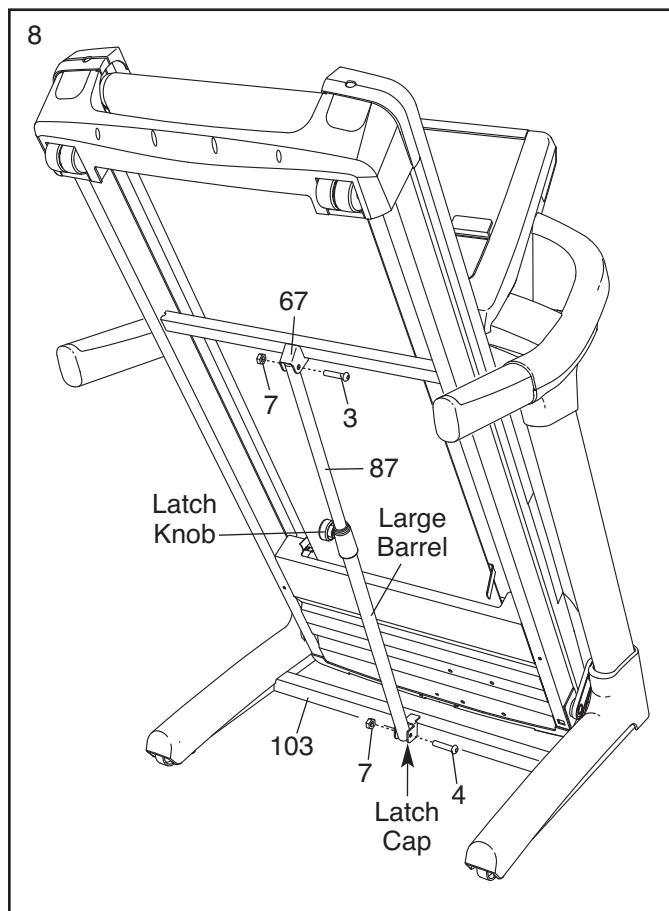

9. With the help of a second person, raise the front of the treadmill and insert the crossbar on the Base (103) into the cutout in the cardboard stand as shown. **Have the second person hold the treadmill to prevent it from moving forward or backward.**

Firmly tighten the four 3/8" x 3 3/4" Bolts (5).

With the help of the second person, lower the treadmill off the cardboard stand.

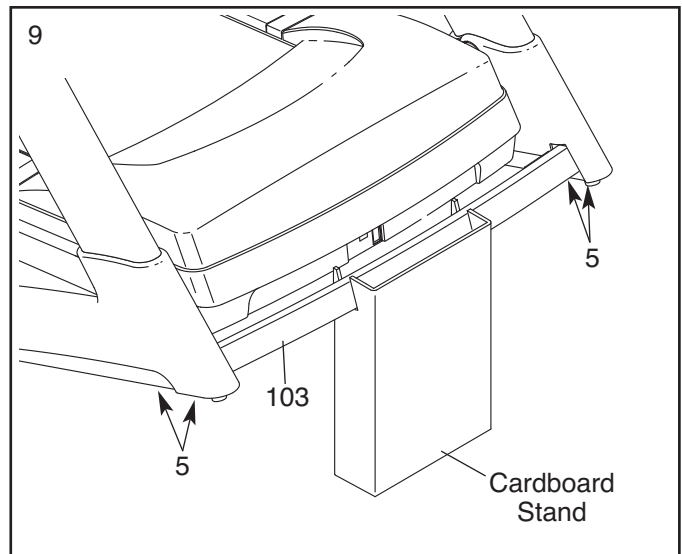

10. **Make sure that all parts are properly tightened before you use the treadmill.** Keep the included hex keys in a secure place; one of the hex keys is used to adjust the walking belt (see pages 29 and 30). **To protect the floor or carpet from damage, place a mat under the treadmill. Extra hardware may be included.**

OPERATION AND ADJUSTMENT

THE PRE-LUBRICATED WALKING BELT

Your treadmill features a walking belt coated with high-performance lubricant. **IMPORTANT: Never apply silicone spray or other substances to the walking belt or the walking platform. Such substances will cause excessive wear.**

HOW TO PLUG IN THE POWER CORD

⚠ DANGER: Improper connection of the equipment-grounding conductor increases the risk of electric shock. Check with a qualified electrician or serviceman if you are unsure whether the product is properly grounded. Do not modify the plug—if it will not fit the outlet, have a proper outlet installed by a qualified electrician.

Your treadmill, like other electronic equipment, can be damaged by sudden voltage changes in your home's power. **To decrease the risk of damaging your treadmill, always use a surge suppressor with your treadmill (see drawing 1 at the right). To purchase a surge suppressor, see precaution 12 on page 3.**

Use only a single-outlet surge suppressor that is UL 1449 listed as a transient voltage surge suppressor (TVSS). The surge suppressor must have a UL suppressed voltage rating of 400 volts or less and a minimum surge dissipation of 450 joules. The surge suppressor must be electrically rated for 120 volts AC and 15 amps. There must be a monitoring light on the surge suppressor to indicate whether it is functioning properly. Failure to use a properly functioning surge suppressor could damage the control system of the treadmill (see precaution 13 on page 3).

This product must be grounded. If it should malfunction or break down, grounding provides a path of least resistance for electric current to reduce the risk of electric shock. This product's power cord has an equipment-grounding conductor and a grounding plug. **Plug the power cord into a surge suppressor, and plug the surge suppressor into an appropriate outlet that is properly installed and grounded in accor-**

dance with all local codes and ordinances.

IMPORTANT: The treadmill is not compatible with GFCI-equipped outlets and may not be compatible with AFCI-equipped outlets.

This product is for use on a nominal 120-volt circuit (see drawing 1). A temporary adapter may be used to connect the surge suppressor to a 2-pole receptacle if a properly grounded outlet is not available (see drawing 2).

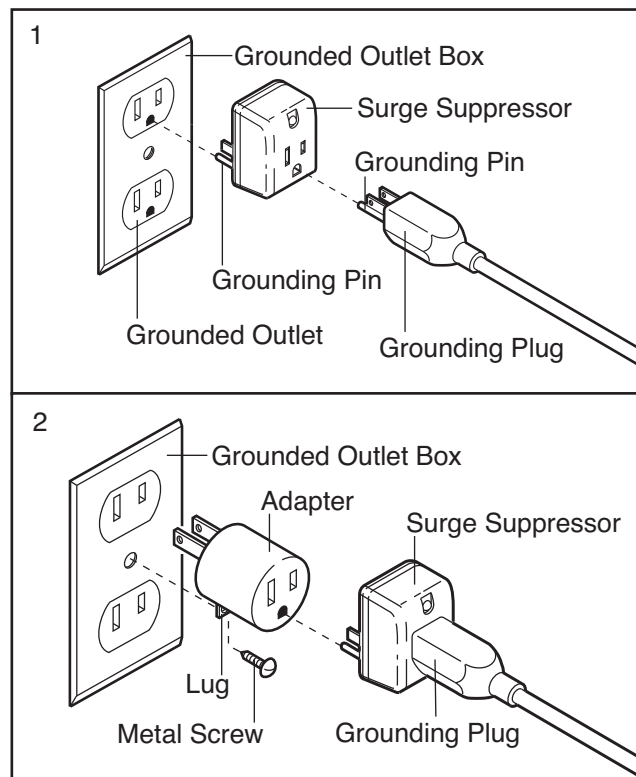

The temporary adapter should be used only until a properly grounded outlet (see drawing 1) can be installed by a qualified electrician.

The green-colored rigid ear, lug, or the like extending from the adapter must be connected to a permanent ground such as a properly grounded outlet box cover. The adapter must be held in place by a metal screw. **Some 2-pole receptacle outlet box covers are not grounded. Contact a qualified electrician to determine if the outlet box cover is grounded before using an adapter.**

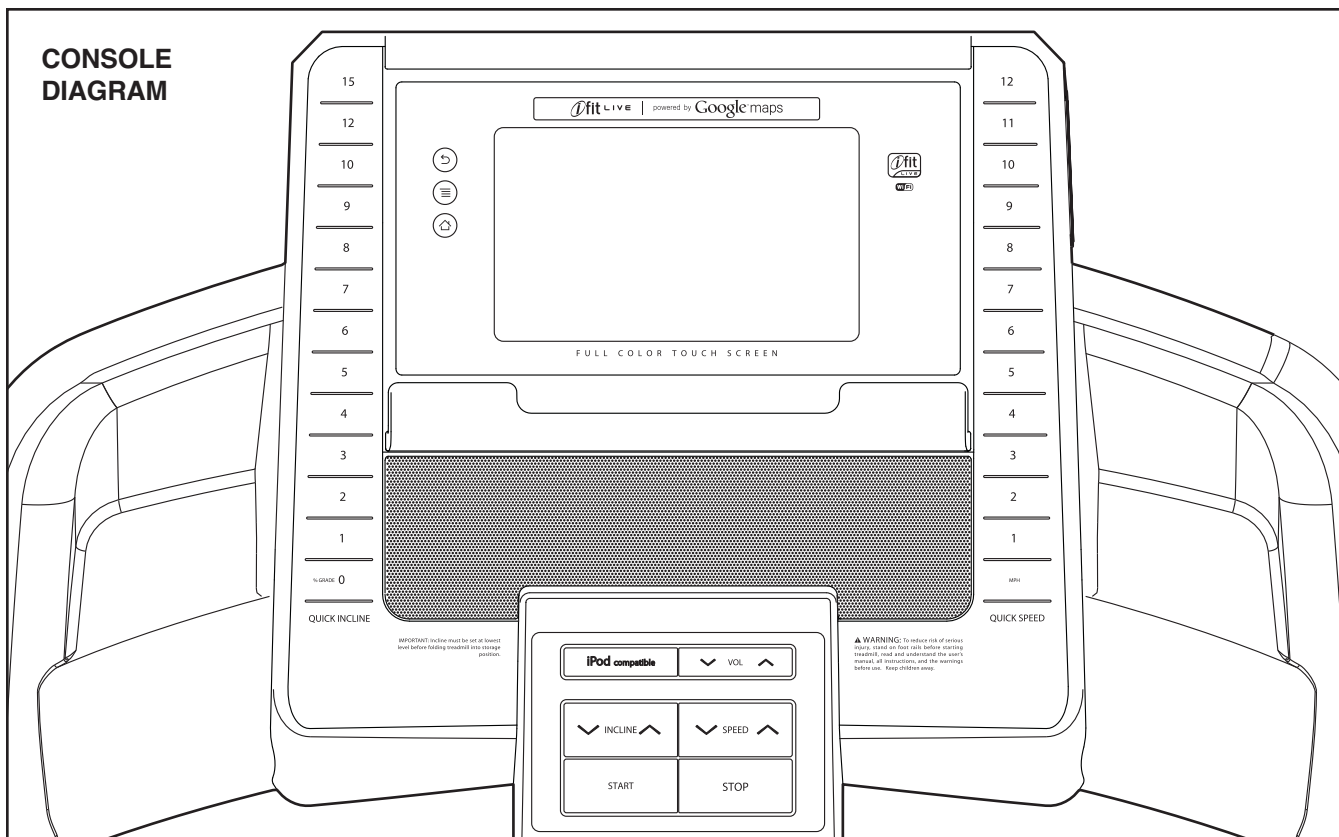

FEATURES OF THE CONSOLE

The treadmill console offers an impressive array of features designed to make your workouts more effective and enjoyable. The console features an iFit Live technology that enables the treadmill to communicate with your wireless network. With the iFit Live mode, you can download personalized workouts, create your own workouts, track your workout results, and access many other features. **See www.iFit.com for complete information.**

In addition, the console features twenty-eight onboard workouts—seven calorie workouts, seven intensity workouts, seven speed workouts, and seven incline workouts. Each workout automatically controls the speed and incline of the treadmill as it guides you through an effective exercise session.

When you use the manual mode, you can change the speed and incline of the treadmill with the touch of a button. As you exercise, the console will display instant exercise feedback. You can also measure your heart rate using the handgrip pulse sensor.

You can even browse the Internet or listen to your favorite workout music or audio books with the console's stereo sound system while you exercise.

To turn on the power, see page 14. **To set up the console**, see page 14. **To use the manual mode**, see page 15. **To use an onboard workout**, see page 18. **To use an iFit Live workout**, see page 19. **To use the Internet browser**, see page 21. **To use the settings mode**, see page 22. **To use the maintenance mode**, see page 24. **To use the stereo sound system**, see page 26.

Note: The console can display speed and distance in either miles or kilometers. To find which unit of measurement is selected, see step 5 on page 23. For simplicity, all instructions in this manual refer to miles.

IMPORTANT: If there are sheets of plastic on the console, remove the plastic. To prevent damage to the walking platform, wear clean athletic shoes while using the treadmill. The first time you use the treadmill, observe the alignment of the walking belt, and center the walking belt if necessary (see page 30).

HOW TO TURN ON THE POWER

IMPORTANT: If the treadmill has been exposed to cold temperatures, allow it to warm to room temperature before you turn on the power. If you do not do this, you may damage the console display or other electrical components.

1. Turn on the power.

Plug in the power cord (see page 12). Next, locate the power switch on the treadmill frame near the power cord. Make sure that the switch is in the reset position.

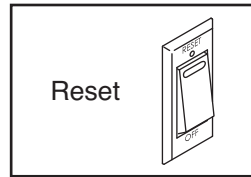

IMPORTANT: The console features a display demo mode, designed to be used if the treadmill is displayed in a store. If the demo mode is turned on, the display will show a demo presentation after you plug in the power cord and press the power switch into the reset position, before you insert the key. To turn off the demo mode, see step 6 on page 23.

2. Insert the key.

Next, stand on the footrails of the treadmill. Locate the clip attached to the key, and slide the clip securely onto the waistband of your clothes. Then, insert the

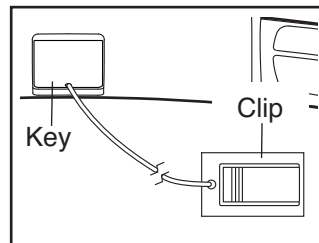

key into the console. **IMPORTANT:** In an emergency, the key can be pulled from the console, causing the walking belt to slow to a stop. Test the clip by carefully taking a few steps backward; if the key is not pulled from the console, adjust the position of the clip.

Note: It may take a minute for the console to be ready for use.

3. Check for firmware updates.

Before using the treadmill for the first time, please check for firmware updates. First, select the maintenance mode (see steps 1 and 2 on page 24). Then, check for firmware updates. (see step 6 on pages 24 and 25).

4. Calibrate the screen.

Before using the treadmill for the first time, please see step 7 on page 25 and calibrate the screen.

5. Calibrate the incline system.

Before using the treadmill for the first time, please see step 3 on page 24 and calibrate the incline system of the treadmill.

HOW TO SET UP THE CONSOLE

The first time you turn on the treadmill, set up your wireless connection and your iFit Live account.

1. Connect to a wireless network.

See steps 1 and 2 on page 22 to connect to a wireless network. Then, touch the home button on the console to return to the settings mode.



An information box may appear to explain how to return to the settings mode. To hide this message in the future, touch the Don't Show Again checkbox. Then, touch the Continue button.

2. Log in to iFit.com.

Touch the globe button near the lower-left corner of the screen. Then, touch the iFit Live button.

A box may appear with directions for navigating in the Internet browser. To hide this message in the future, touch the Don't Show Again checkbox. Then, touch the Continue button. Note: For information about navigating in the browser, see page 21.

The browser will open to the iFit.com home page. Touch the Register Now button in the upper-right corner of the screen.

The browser will open to the iFit.com registration page. Touch an entry box to view the keyboard. Slide your finger up or down the screen to scroll up or down the page.

Next, enter a username and password and your e-mail address. Enter the activation code from the iFit Live flier that came with the treadmill. Touch the Place of Purchase drop-down menu for a list of options; then, touch the location where you purchased your product. Touch the words MEDICAL DISCLAIMER, read the medical disclaimer, touch the I Accept button, and check the medical disclaimer checkbox. Then, touch the Confirm Activation Code button.

Enter the requested personal information. When you have entered all of the information, touch the Finish button. When the registration process is complete, press the home button on the console to exit the browser.

3. Begin working out.

Touch the iFit Live Login button. The screen will ask for your iFit.com user name and password. Enter them and touch the Submit button. Touch the Cancel button to exit the login screen.

The console will display the iFit Live welcome screen. Before some workouts will download, you must add the workouts to your schedule on iFit.com. For more information about iFit Live workouts, see pages 19 and 20 or go to www.iFit.com.

HOW TO USE THE MANUAL MODE

1. Insert the key into the console.

See HOW TO TURN ON THE POWER on page 14. **Note: It may take a minute for the console to be ready for use.**

2. Select the start-up menu.

Each time the key is inserted, the start-up menu will appear. If you have selected a workout or the iFit Live mode, touch the home button in the lower left corner

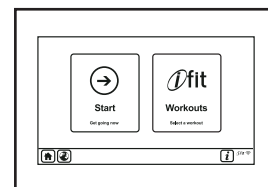

of the screen. Next, touch the End Workout button and then touch the Done button to return to the start-up menu.

3. Start the walking belt and adjust the speed.

To start the walking belt, touch the Start button on the screen or the Start button on the console. The walking belt will begin to move at 1 mph. As you exercise, change the speed of the walking belt as desired by pressing the Speed increase and decrease buttons. Each time you press one of the buttons, the speed setting will change by 0.1 mph; if you hold down the button, the speed setting will change in increments of 0.5 mph.

If you press one of the numbered Quick Speed buttons, the walking belt will gradually change speed until it reaches the selected speed setting. To select a speed setting that includes a decimal—such as 3.5 mph—press two numbered buttons in succession. For example, to select a speed setting of 3.5 mph, press the 3 button and then immediately press the 5 button.

To stop the walking belt, press the Stop button. To restart the walking belt, press the Start button.

4. Change the incline of the treadmill as desired.

To change the incline of the treadmill, press the Incline increase and decrease buttons or one of the numbered Quick Incline buttons. Each time you press one of the buttons, the incline will gradually change until it reaches the selected incline setting.

Note: The first time you adjust the incline, you must first calibrate the incline system (see step 3 on page 24).

5. Monitor your progress.

The console offers several display modes. The display mode that you select will determine which workout information is shown. To select the desired display mode, repeatedly touch the Display increase or decrease button on the screen.

As you walk or run on the treadmill, the screen can show the following workout information:

- The incline level of the treadmill
- The elapsed time
- The approximate number of calories you have burned
- The distance that you have walked or run
- The speed of the walking belt
- A track representing 1/4 mile (400 meters)
- Your pace in minutes per mile
- Your current lap number

- The time remaining
- The approximate number of calories burned per hour
- The number of vertical feet you have climbed
- Your heart rate (see step 6 on page 17).

The displays at the top of the screen can show two types of information. Touch each display until the display shows the desired information. Note: The manual mode does not have a time remaining countdown.

If desired, adjust the volume level by pressing the volume (Vol) increase and decrease buttons on the console.

To reset the console, touch the home button in the lower left corner of the screen. To pause the workout, touch the Pause button. To continue the workout, touch the Resume button or the Start button. To end the workout and select a new workout, touch the New Workout button. To end the workout session, touch the End Workout button.

Note: The small wireless symbol in the lower right corner of the screen will show your wireless connection status. If the symbol is green, the treadmill is connected to your wireless network and you have logged in to iFit.com. If the symbol is orange, the treadmill is connected to your wireless network. If the symbol is black, the treadmill is not connected to your wireless network.



6. Measure your heart rate if desired.

Before using the handgrip pulse sensor, remove the sheets of plastic from the metal contacts on the pulse bar. In addition, make sure that your hands are clean.

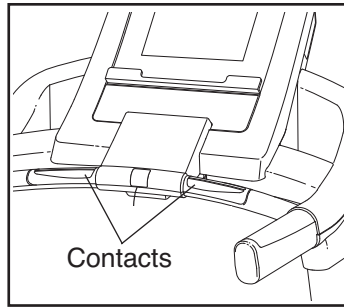

To measure your heart rate, **stand on the foot rails** and hold the pulse bar with your palms on the metal contacts; **avoid moving your hands**. When your pulse is detected, your heart rate will be shown. **For the most accurate heart rate reading, continue to hold the contacts for about 15 seconds.**

7. When you are finished exercising, remove the key from the console.

Step onto the foot rails, press the Stop button, and **adjust the incline of the treadmill to the lowest incline setting. The incline must be at the lowest incline setting or you may damage the treadmill when you fold it to the storage position.** Next, remove the key from the console and put it in a secure place.

When you are finished using the treadmill, press the power switch into the off position and unplug the power cord. **IMPORTANT: If you do not do this, the treadmill's electrical components may wear prematurely.**

HOW TO USE AN ONBOARD WORKOUT

1. Insert the key into the console.

See step 1 on page 15.

2. Select the start-up menu.

See step 2 on page 15.

3. Select an onboard workout.

To select an onboard workout, touch the Workouts button on the screen. Then, touch the Calorie Burn button, the High Intensity button, the Speed Training button, or the Incline Workouts button. Touch the home button on the screen to view the previous screen.

Then, select the desired workout. The screen will show the name, duration, and distance of the workout. The screen will also show the approximate number of calories you will burn during the workout and a profile of the incline settings of the workout.

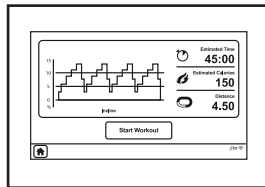

4. Start the workout.

Touch the Start Workout button to start the workout. A moment after you touch the button, the walking belt will begin to move. Hold the handrails and begin walking.

Each workout is divided into segments. One speed setting and one incline setting are programmed for each segment. Note: The same speed setting and/or incline setting may be programmed for consecutive segments.

During the workout, the profile will show your progress. Touch the Display increase and decrease buttons repeatedly to view the profile. The colored line will indicate the current segment of the workout. The colored profile represents the incline setting of the current segment. The black line represents the speed setting of the current segment.

At the end of the first segment of the workout, the treadmill will automatically adjust to the speed and/or incline settings for the next segment. If a different speed and/or incline setting is programmed for the second segment, the speed setting and/or incline setting will flash on the screen for a moment to alert you.

The workout will continue in this way until the last segment ends. The walking belt will then slow to a stop and a workout summary will appear on the screen. After you view the workout summary, touch the Done button.

If the speed or incline setting is too high or too low at any time during the workout, you can override the setting by pressing the Speed or Incline buttons; **however, when the next segment begins, the treadmill will automatically adjust to the speed and incline settings for the next segment.**

To reset the console, touch the home button on the screen. To pause the workout, touch the Pause button. To continue the workout, touch the Resume button or the Start button. To end the workout and select a new workout, touch the New Workout button. To end the workout session, touch the End Workout button.

Note: The calorie goal is an estimate of the number of calories that you will burn during the workout. The actual number of calories that you burn will depend on your weight. In addition, if you manually change the speed or incline of the treadmill during the workout, the number of calories you burn will be affected.

5. Monitor your progress.

See step 5 on page 16. The screen can also show a profile of the speed and incline settings of the workout.

6. Measure your heart rate if desired.

See step 6 on page 17.

7. When you are finished exercising, remove the key from the console.

See step 7 on page 17.

HOW TO USE AN IFIT LIVE WORKOUT

Note: To use an iFit Live workout, you must have access to a wireless network including an 802.11b/n router with SSID broadcast enabled (hidden networks are not supported). An iFit.com membership is also required.

1. Insert the key into the console.

See step 1 on page 15.

2. Log in to iFit.com.

If you have not already done so, log in to your iFit.com account (see step 3 on page 23).

3. Select the start-up menu.

See step 2 on page 15.

4. Select an iFit Live workout.

Touch the Workouts button on the screen. To select an iFit Live workout, touch the iFit Live button and select the type of workout.

To switch users within the account, touch the user button near the lower right corner of the screen.

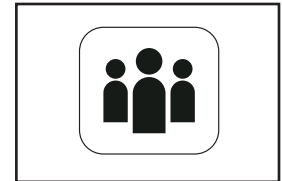

Before some workouts will download, you must add the workouts to your schedule on iFit.com.

Next, touch the round Start Download button to download the next workout in your schedule. Touch the My Trainer button, the My Maps button, the World

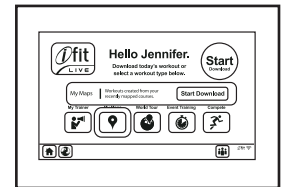

Tour button, or the Event Training button to download the next workout of that type in your schedule. Touch the Compete button to compete in a race that you have previously scheduled. Then, touch the Start Download button. **For more information about the iFit Live workouts, please see www.iFit.com.**

When you select an iFit Live workout, the screen will show the name, duration, and distance of the workout. The screen will also show the approximate number of calories you will burn during the workout. If you select a competition workout, the display will count down to the beginning of the race.

5. Start the workout.

See step 4 on pages 18 and 19.

During some workouts, the voice of a personal trainer will guide you through your workout.

6. Monitor your progress.

See step 5 on page 16. The screen may also show a map of the trail you are walking or running.

During a competition workout, the screen will show the speeds of the runners and the distances they have run. The screen will also show the numbers of seconds that the other runners are ahead of you or behind you.

7. Measure your heart rate if desired.

See step 6 on page 17.

8. When you are finished exercising, remove the key from the console.

See step 7 on page 17.

For more information about the iFit Live mode, go to www.iFit.com.

IFIT LIVE FCC INFORMATION

IMPORTANT: To comply with FCC and IC RF exposure compliance requirements, the antenna used for this transmitter must be installed to provide a separation distance of at least 20 cm from all persons and must not be co-located or operating in conjunction with any other antenna or transmitter.

This equipment has been tested and found to comply with the limits for a Class B digital device, pursuant to

Part 15 of the FCC Rules. These limits are designed to provide reasonable protection against harmful interference in a residential installation. This equipment generates, uses, and can radiate radio frequency energy and, if not installed and used in accordance with the instructions, may cause harmful interference to radio communications. However, there is no guarantee that interference will not occur in a particular installation. If this equipment does cause harmful interference to radio or television reception, which can be determined by turning the equipment off and on, the user is encouraged to try to correct the interference by one of the following measures:

- Reorient or relocate the receiving antenna.
- Increase the separation between the equipment and the receiver.
- Connect the equipment into an outlet on a circuit different from that to which the receiver is connected.
- Consult the dealer or an experienced radio/TV technician for help.

FCC CAUTION: To assure continued compliance, use only shielded interface cables when connecting to computer or peripheral devices. Any changes or modifications not expressly approved by the party responsible for compliance could void the user's authority to operate this equipment.

This device complies with Part 15 of the FCC Rules. Operation is subject to the following two conditions: (1) This device may not cause harmful interference, and (2) this device must accept any interference received, including interference that may cause undesired operation.

If you have questions after reading this information, please call Customer Care toll-free at 1-866-608-1798, Mon.–Fri. 6 am–6 pm MT, Sat. 8 am–4 pm MT (closed on holidays); visit www.iFit.com/support; or send e-mail to service@iconfitness.com.

HOW TO USE THE INTERNET BROWSER

Note: To use the browser, you must have access to a wireless network including an 802.11b/n router with SSID broadcast enabled (hidden networks are not supported).

To open the browser, touch the globe button near the lower left corner of the screen. Then, select a website. Navigate through the browser using the back button, the menu button, and the home button on the console.

Press the back button to return to the previous web page. To exit the browser, press the home button on the console.

Press the Menu button to view the browser menu. The menu offers the following options:

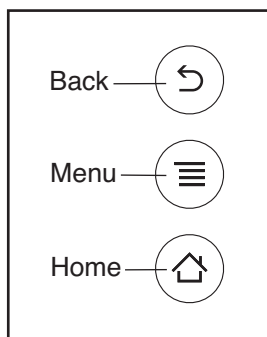

New window—A new window will open.

Bookmarks—All of your bookmarks will be displayed. Touch the desired bookmark to select it or touch the Add button to add a new bookmark (see Add bookmark below). Touch the Most Viewed tab to see which pages are viewed the most often. Touch the History tab to see all the pages that have been viewed recently.

Windows—A list of all of your open windows will be displayed. Touch the desired window to select it or touch the X button to close a window.

Refresh—The current page will reload.

Forward—If you have pressed the back button, the browser will return to the previous page.

Touch the More button to view the following options:

Add bookmark—The current page will appear in the text box. Touch the OK button to set the current page as a bookmark. Touch the Cancel button to return to the browser.

To select a different page, touch the name text box, enter the name of the bookmark, and touch the Next

button. Then, enter the address of the page and touch the Done button.

Find on page—A search box will appear on the bottom of the screen. Touch the text box, enter the text you wish to search for, and touch the Done button. Touch the arrow buttons to view each instance of the text. Touch the X button to close the search box.

Select text—After you touch the Select Text button, drag your finger along the screen to select text. The selected text will be copied to the clipboard in the console's memory. To paste the text, touch and hold a text box and then touch the Paste button.

Page info—Information about the current page will be displayed. Touch the OK button to return to the browser.

Share page—This feature is not enabled.

Downloads—A list of all the files you have downloaded will be displayed.

Settings—The browser settings will be displayed. Drag your finger up or down the screen to scroll through the settings. If there is a checkbox, touch the checkbox to turn the feature on or off. If there is a triangle, touch the triangle to view a list of options and touch the desired option. To restore the default browser settings, select RESET TO DEFAULT at the bottom of the list and touch the OK button.

To view the keyboard, touch a text box on the screen. See step 2 on page 22 for instructions about how to use the keyboard.

To enter a different web address in the URL bar, first, slide your finger down the screen to view the URL bar, if necessary. Then, touch the URL bar, use the keyboard to enter the address, and touch the Go button.

Note: While you are using the browser, the speed, incline, and volume buttons will still function, but the workout buttons will not function.

If it is difficult to touch the buttons, see step 7 on page 25 to calibrate the screen.

Note: If you have questions after following these instructions, go to www.iFit.com/support for assistance.

HOW TO USE THE SETTINGS MODE

The console features a settings mode that allows you to connect the treadmill to your own wireless network and to log in to your iFit Live account. The settings mode also allows you to select the unit of measurement and to turn on and turn off the display demo mode. You may also be able to select a language.

1. Select the settings mode.

Insert the key into the console (see step 1 on page 15). Next, select the start-up menu (see step 2 on page 15).

Then, touch the **i** button near the lower right corner of the screen to select the settings mode.

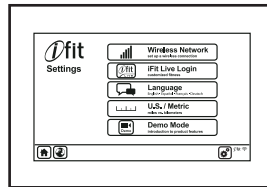

2. Select the wireless network mode.

If desired, touch the Wireless Network button on the screen. Note: It may take a few moments for the list of wireless networks to appear.

Note: You must have your own wireless network and an 802.11b/n router with SSID broadcast enabled (hidden networks are not supported).

Make sure the WiFi checkbox near the upper right corner of the screen is marked with a green checkmark. If it is not, touch the checkbox once and wait for a few seconds. The console will search for available wireless networks.

When a list of networks appears, touch the desired network. Note: You will need to know your network name (SSID). If your network has a password, you will also need to know the password.

An information box will ask if you want to connect to the wireless network. Touch the Connect button to connect to the network. Touch the Cancel button to return to the list of networks. If the network has a password, touch the password entry box. A keyboard will appear on the screen. To view the password as you type it, touch the Show Password checkbox.

To use numbers or other characters on the keyboard on the screen, touch the **?123** button. To view more characters, touch the **Alt** button. Touch the **Alt** button again to return to the number keyboard. To return to the letter keyboard, touch the **ABC** button. To view capital characters, touch the button with an upward-facing arrow. To return to the lowercase keyboard, touch the arrow button again. To clear the last character, touch the button with a backward-facing arrow and an **X**.

When the console has connected to your wireless network, the WiFi box at the top of the screen will display the word **CONNECTED**. Then, touch the home button on the console to return to the settings mode.

To disconnect from a wireless network, select the wireless network and touch the **Forget** button.

If you are having problems connecting to an encrypted network, make sure your password is correct. Note: Passwords are case-sensitive.

Note: The iFit Live mode supports unsecured and secured (WEP, WPA, and WPA2) encryption. A broadband connection is recommended; performance depends on connection speed.

Note: If you have questions after following these instructions, go to www.iFit.com/support for assistance.

3. Log in to your iFit Live account.

To log in to a different iFit Live account, touch the iFit Live Login button. Then, enter your user name and password using the keyboard on the screen. See step 2 on page 22 for instructions about using the keyboard. When you are finished, touch the Submit button. To return to the settings mode, touch the Cancel button. Note: To switch users within an iFit Live account, see step 4 on page 19.

To set up an iFit Live account, or for more information about the account, go to www.iFit.com.

4. Select a language.

To select a language, touch the Language button and select the desired language. Then, touch the home button on the screen to return to the settings mode. Note: This feature may not be available in the United States.

5. Select the unit of measurement.

Touch the US/Metric button to view the selected unit of measurement. Change the unit of measurement, if desired. Then, touch the home button on the screen.

6. Turn on or turn off the display demo mode.

The console features a display demo mode, designed to be used if the treadmill is displayed in a store. While the demo mode is turned on, the console will function normally when you plug in the power cord, press the power switch into the reset position, and insert the key into the console. However, when you remove the key, the screen will show a demo presentation.

To turn on or turn off the display demo mode, first touch the Demo Mode button. Next, touch the On checkbox or the Off checkbox. Then, touch the home button on the screen.

7. Exit the settings mode.

To exit the settings mode, touch the home button on the screen.

HOW TO USE THE MAINTENANCE MODE

The console features a maintenance mode that allows you to calibrate the incline and speed of the treadmill, restore factory defaults, update the console firmware, calibrate the screen, view technical information, and perform a network test.

1. Select the settings mode.

See step 1 on page 22.

2. Select the maintenance mode.

Touch the Maintenance button in the lower right corner of the screen to enter the maintenance mode.

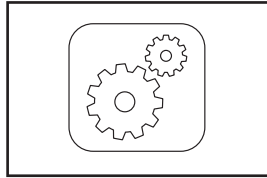

The maintenance mode main screen will show information about the model and version of the treadmill. If the console is connected to the controller of the treadmill, the controller dot will be green; if it is not, the dot will flash. If the treadmill is connected to your wireless network, the network dot will be green; if it is not, the dot will be black.

3. Calibrate the incline system of the treadmill.

Touch the Calibrate Incline button. Then, touch the Begin button to calibrate the incline system. The treadmill will automatically rise to the maximum incline level, lower to the minimum incline level, and then return to the starting position. This will calibrate the incline system. Press the Cancel button to return to the maintenance mode. When the incline system is calibrated, touch the Finish button.

IMPORTANT: Keep pets, feet, and other objects away from the treadmill while the incline system is calibrating. In an emergency, pull the key from the console to stop the incline calibration.

4. Calibrate the speed of the treadmill.

Calibrate the speed of the treadmill only if instructed to do so by an authorized service representative.

Note: The Calibrate Speed button may not be enabled on your treadmill.

5. Restore factory defaults.

If necessary, touch the Restore Defaults button to reset the firmware to the original factory firmware. This will erase all firmware updates that you have downloaded. Touch the Begin button to restore the default firmware or the Cancel button to return to the maintenance mode. **To avoid damaging the treadmill, do not turn off the power or remove the key while the factory defaults are being restored.**

When the restoration is complete, the treadmill will turn off and then turn back on. If it does not, press the power switch into the off position. Wait for several seconds, and then press the power switch into the reset position. It may take a few minutes for the console to be ready for use.

6. Update the console firmware.

For the best results, regularly check for firmware updates.

Touch the Firmware Update button. Next, touch the WiFi button to check for firmware updates using your wireless network. Then, touch the Begin button to check for updates or the Cancel button to return to the maintenance mode.

To avoid damaging the treadmill, do not turn off the power or remove the key while the firmware is being updated.

Note: If you cannot update the console firmware over your wireless network, you can update the firmware using a USB drive. Touch the USB button to install firmware updates using a USB drive. Go to www.iFit.com and download the firmware update onto your USB drive. Safely remove the USB drive from your computer and plug it into the USB port on the side of the console. Touch the Begin button on the screen or touch the Cancel button to return to the maintenance mode.

The screen will show the progress of the update. When the update is complete, the treadmill will turn off and then turn back on. If it does not, press the power switch into the off position. Wait for several seconds, and then press the power switch into the reset position. It may take a few minutes for the console to be ready for use.

7. Calibrate the screen.

If the screen is not properly calibrated, it will be difficult for you to touch the correct buttons on the screen. To calibrate the screen, touch the Calibrate Screen button and then touch the Begin button. Touch the Cancel button to return to the maintenance mode. A small target will appear on the screen.

Using a pencil eraser or other small object, touch the center of the target. Then, touch the rest of the targets. After several seconds, the console will exit the calibration mode.

Note: If it is difficult to touch the buttons while using the Internet browser, the browser screen should be calibrated. Press and hold the menu button on the console until a + appears on the screen. Using a pencil eraser or other small object, touch and hold the center of the + for a second. Then, touch and hold the rest of the targets. After a few seconds, the console will exit the calibration mode.

8. View technical information.

Touch the Technical Info button to view the total number of hours that the treadmill has been used, the total number of miles that the walking belt has moved, and other information. After you view the information, touch the Finish button.

9. Perform a network test.

Touch the Network Test button to check the connection status of the treadmill. The wireless interface status shows whether the wireless feature on the treadmill is turned on or turned off. The network access status shows whether the treadmill can connect to your wireless network. The DNS service status shows whether the treadmill can communicate with the DNS server. The iFit.com status shows whether the treadmill can communicate with iFit.com. If all the connections are successful, the console will display the word SUCCESS. After you view the information, touch the Finish button.

10. Access the Android™ desktop.

Access the Android desktop only if instructed to do so by an authorized service technician.

From the desktop, you can change settings and maintain your console. Touch the Android Desktop button to access the desktop. Press the home button on the console to exit the desktop.

11. Exit the maintenance mode.

To exit the maintenance mode, touch the home button on the screen repeatedly.

HOW TO USE THE STEREO SOUND SYSTEM

To play music or audio books through the console's speakers, you must connect your MP3 player, CD player, or other personal audio player to the console.

Locate the audio wire. Plug one end into the audio jack on the side of the console. Then, plug the other end into a jack on your MP3 player, CD player, or other personal audio player. **Make sure that the audio wire is fully plugged in.**

Next, press the Play button on your MP3 player, CD player, or other personal audio player. Then, adjust the volume level on your personal audio player or press the Vol increase and decrease buttons on the console.

If you are using a personal CD player and the CD skips, set the CD player on the floor or another flat surface instead of on the console.

Note: The USB port on the side of the console is for software updates only.

HOW TO ADJUST THE CUSHIONING SYSTEM

Remove the key from the console and unplug the power cord. The treadmill features a cushioning system that reduces the impact as you walk or run on the treadmill. To increase the firmness of the walking platform, step off the treadmill and slide the platform cushions toward the front of the treadmill. To decrease the firmness, slide the platform cushions toward the back of the treadmill. **Note: Make sure that both cushions are set at the same firmness level. The faster you run on the treadmill, or the more you weigh, the firmer the walking platform should be.**

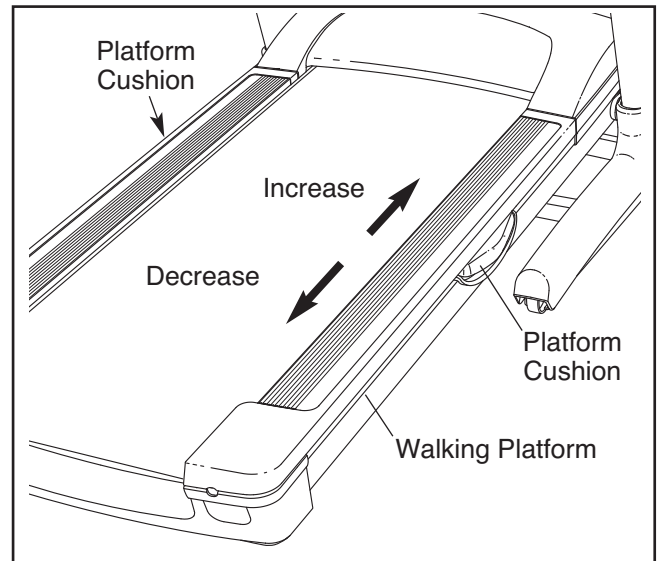

HOW TO FOLD AND MOVE THE TREADMILL

HOW TO FOLD THE TREADMILL

To avoid damaging the treadmill, adjust the incline to the lowest position before you fold the treadmill. Then, remove the key and unplug the power cord. **CAUTION: You must be able to safely lift 45 lbs. (20 kg) to raise, lower, or move the treadmill.**

1. Hold the metal frame firmly in the location shown by the arrow below. **CAUTION: Do not hold the frame by the plastic foot rails. Make sure to bend your legs and keep your back straight.**

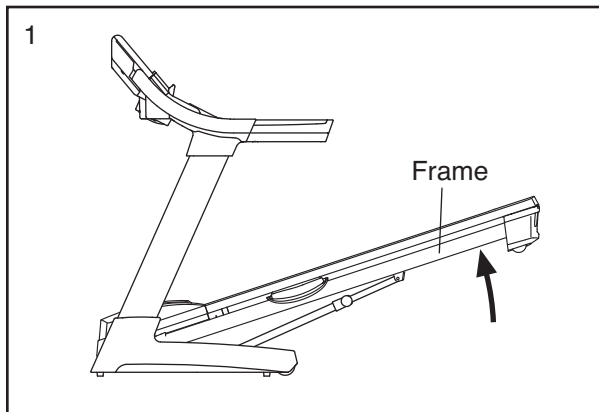

2. Raise the frame until the latch knob locks in the storage position. **CAUTION: Make sure that the latch knob locks.**

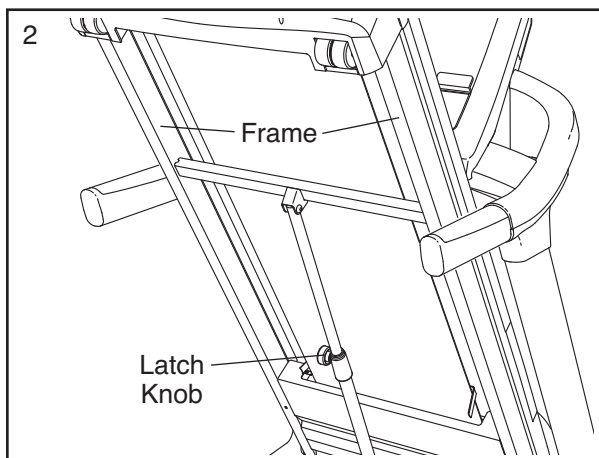

To protect the floor or carpet, place a mat under the treadmill. Keep the treadmill out of direct sunlight. Do not leave the treadmill in the storage position in temperatures above 85° F (30° C).

HOW TO MOVE THE TREADMILL

Before moving the treadmill, fold it as described at the left. **CAUTION: Make sure that the latch knob is locked in the storage position. Moving the treadmill may require two people.**

1. Hold the frame and one of the handrails, and place one foot against a wheel.

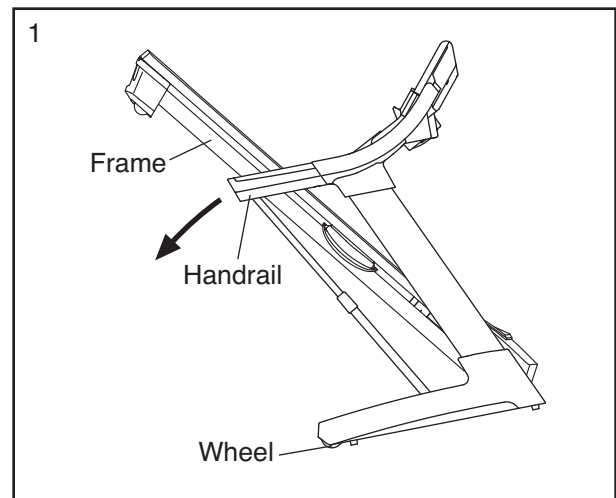

2. Pull back on the handrail until the treadmill will roll on the wheels, and carefully move it to the desired location. **CAUTION: Do not move the treadmill without tipping it back, do not pull on the frame, and do not move the treadmill over an uneven surface.**
3. Place one foot against a wheel, and carefully lower the treadmill.

HOW TO LOWER THE TREADMILL FOR USE

1. **See drawing 2.** Hold the upper end of the treadmill with your right hand. Pull the latch knob to the left; if necessary, push the frame forward slightly. Pivot the frame downward a few inches, and release the latch knob.
2. **See drawing 1 at the left.** Hold the metal frame firmly with both hands, and lower it to the floor. **CAUTION: Do not hold the frame by the plastic foot rails, and do not drop the frame. Make sure to bend your legs and keep your back straight.**

TROUBLESHOOTING

Most treadmill problems can be solved by following the steps below. Find the problem that applies, and follow the steps listed. If further assistance is needed, please see the front cover of this manual.

PROBLEM: The power does not turn on

SOLUTION: a. Make sure that the power cord is plugged into a surge suppressor, and that the surge suppressor is plugged into a properly grounded outlet (see page 12). Use only a single-outlet surge suppressor that meets all of the specifications described on page 12. **IMPORTANT: The treadmill is not compatible with GFCI-equipped outlets and may not be compatible with AFCI-equipped outlets.**

b. After the power cord has been plugged in, make sure that the key is inserted into the console.

c. Check the power switch located on the treadmill frame near the power cord. If the switch protrudes as shown, the switch has tripped. To reset the switch, wait for five minutes and then press the switch back in.

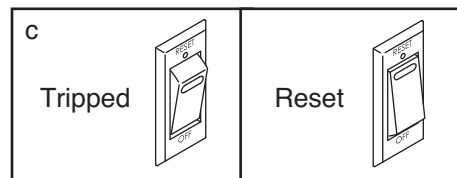

PROBLEM: The power turns off during use

SOLUTION: a. Check the power switch (see the drawing above). If the switch has tripped, wait for five minutes and then press the switch back in.

b. Make sure that the power cord is plugged in. If the power cord is plugged in, unplug it, wait for five minutes, and then plug it back in.

c. Remove the key from the console. Reinsert the key into the console.

d. If the treadmill still will not run, please see the front cover of this manual.

PROBLEM: The console screen remains lit when you remove the key from the console

SOLUTION: a. The console features a display demo mode, designed to be used if the treadmill is displayed in a store. If the screen shows a demo presentation when you remove the key, the demo mode is turned on. To turn off the demo mode, hold down the Stop button for a few seconds. If the demo mode is still on, see step 6 on page 23 to turn off the demo mode.

PROBLEM: The console does not display speed and distance correctly

SOLUTION: a. Remove the key from the console and **UNPLUG THE POWER CORD**. Then, place the treadmill in the storage position (see HOW TO FOLD THE TREADMILL on page 27).

Next, remove the two indicated #8 x 3/4" Screws (1).

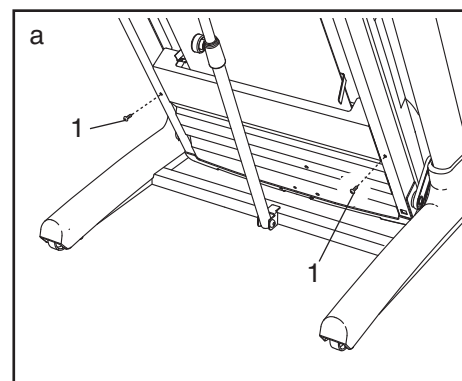

Lower the treadmill (see HOW TO LOWER THE TREADMILL FOR USE on page 27). Remove the four indicated #8 x 3/4" Screws (1), and remove the Motor Hood (75).

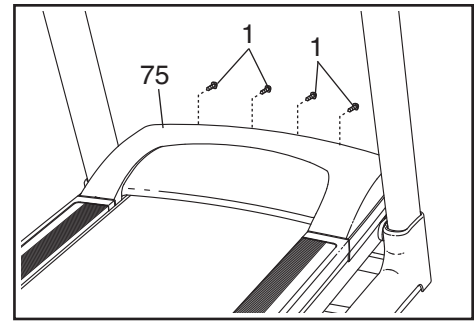

Next, locate the Reed Switch (53) and the Magnet (58) on the left side of the Pulley (59). Turn the Pulley until the Magnet is aligned with the Reed Switch.

Make sure that the gap between the Magnet and the Reed Switch is about 1/8 in. (3 mm). If necessary, loosen the indicated #8 x 3/4" Tek Screw (24), move the Reed Switch slightly, and then retighten the Screw. Then, reattach the Motor Hood (not shown) with the six #8 x 3/4" Screws (not shown), and run the treadmill for a few minutes to check for a correct speed reading.

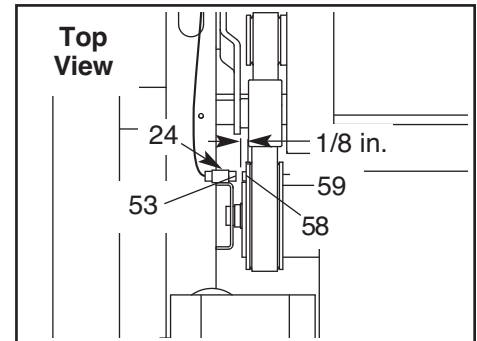

PROBLEM: The incline of the treadmill does not change correctly

SOLUTION: a. Recalibrate the incline system (see step 3 on page 24).

PROBLEM: The iFit Live mode does not function correctly

SOLUTION: a. If the iFit Live mode is not functioning correctly, make sure that the treadmill has the most current firmware available (see step 6 on pages 24 and 25).

PROBLEM: The walking belt slows when walked on

SOLUTION: a. Use only a single-outlet surge suppressor that meets all of the specifications described on page 12.

b. If the walking belt is overtightened, treadmill performance may decrease and the walking belt may become damaged. Remove the key and **UNPLUG THE POWER CORD**. Using the hex key, turn both idler roller bolts counterclockwise, 1/4 of a turn. When the walking belt is properly tightened, you should be able to lift each edge of the walking belt 3 to 4 in. (8 to 10 cm) off the walking platform. Be careful to keep the walking belt centered. Then, plug in the power cord, insert the key, and run the treadmill for a few minutes. Repeat until the walking belt is properly tightened.

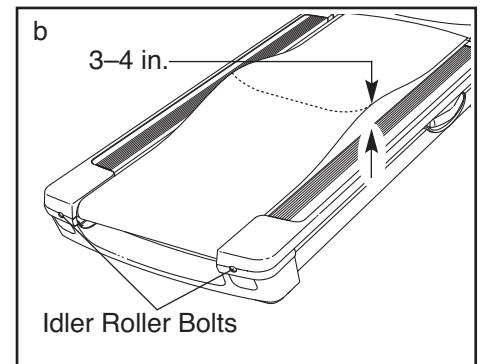

c. If the walking belt still slows when walked on, please see the front cover of this manual.

PROBLEM: The walking belt is off-center or slips when walked on

SOLUTION: a. If the walking belt is off-center, remove the key and **UNPLUG THE POWER CORD**. If the walking belt has shifted to the left, use the hex key to turn the left idler roller bolt clockwise 1/2 of a turn; if the walking belt has shifted to the right, turn the left idler roller bolt counterclockwise 1/2 of a turn. Be careful not to overtighten the walking belt. Plug in the power cord, insert the key, and run the treadmill for a few minutes. Repeat until the walking belt is centered.

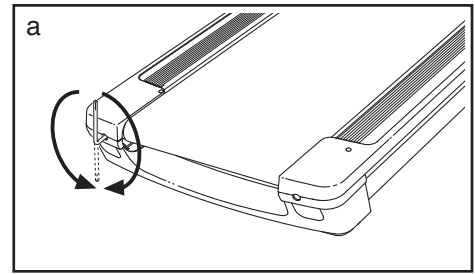

b. If the walking belt slips when walked on, first remove the key and **UNPLUG THE POWER CORD**. Using the hex key, turn both idler roller bolts clockwise, 1/4 of a turn. When the walking belt is correctly tightened, you should be able to lift each edge of the walking belt 3 to 4 in. (8 to 10 cm) off the walking platform. Be careful to keep the walking belt centered. Then, plug in the power cord, insert the key, and carefully walk on the treadmill for a few minutes. Repeat until the walking belt is properly tightened.

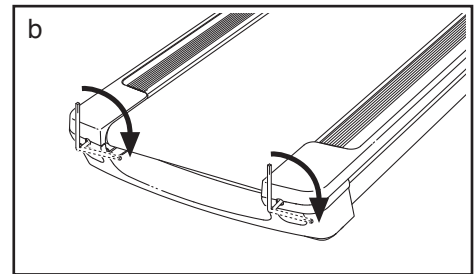

PROBLEM: The treadmill will not connect to the wireless network

SOLUTION: a. Perform a network test (see step 9 on page 25).

b. Make sure the wireless settings on your console are correct (see step 2 on page 22).

c. Make sure the settings for your wireless network are correct.

d. If you still have questions, see the front cover of this manual.

PROBLEM: The buttons on the screen do not work correctly

SOLUTION: a. If the screen is not properly calibrated, it will be difficult to touch the correct buttons on the screen. To calibrate the screen, see step 7 on page 25.

EXERCISE GUIDELINES

⚠️ WARNING: Before beginning any exercise program, consult your physician. This is especially important for persons over age 35 or persons with pre-existing health problems.

The pulse sensor is not a medical device. Various factors may affect the accuracy of heart rate readings. The pulse sensor is intended only as an exercise aid in determining heart rate trends in general.

These guidelines will help you to plan your exercise program. For detailed exercise information, obtain a reputable book or consult your physician. Remember, proper nutrition and adequate rest are essential for successful results.

EXERCISE INTENSITY

Whether your goal is to burn fat or to strengthen your cardiovascular system, exercising at the proper intensity is the key to achieving results. You can use your heart rate as a guide to find the proper intensity level. The chart below shows recommended heart rates for fat burning and aerobic exercise.

165	155	145	140	130	125	115	♥♥
145	138	130	125	118	110	103	♥
125	120	115	110	105	95	90	♥
<hr/>							
20	30	40	50	60	70	80	

To find the proper intensity level, find your age at the bottom of the chart (ages are rounded off to the nearest ten years). The three numbers listed above your age define your “training zone.” The lowest number is the heart rate for fat burning, the middle number is the heart rate for maximum fat burning, and the highest number is the heart rate for aerobic exercise.

Burning Fat—To burn fat effectively, you must exercise at a low intensity level for a sustained period of time. During the first few minutes of exercise, your body uses *carbohydrate calories* for energy. Only after the first few minutes of exercise does your body begin to use stored *fat calories* for energy. If your goal is to burn fat, adjust the intensity of your exercise until your heart rate is near the lowest number in your training zone. For maximum fat burning, exercise with your heart rate near the middle number in your training zone.

Aerobic Exercise—If your goal is to strengthen your cardiovascular system, you must perform aerobic exercise, which is activity that requires large amounts of oxygen for prolonged periods of time. For aerobic exercise, adjust the intensity of your exercise until your heart rate is near the highest number in your training zone.

WORKOUT GUIDELINES

Warming Up—Start with 5 to 10 minutes of stretching and light exercise. A warm-up increases your body temperature, heart rate, and circulation in preparation for exercise.

Training Zone Exercise—Exercise for 20 to 30 minutes with your heart rate in your training zone. (During the first few weeks of your exercise program, do not keep your heart rate in your training zone for longer than 20 minutes.) Breathe regularly and deeply as you exercise—never hold your breath.

Cooling Down—Finish with 5 to 10 minutes of stretching. Stretching increases the flexibility of your muscles and helps to prevent post-exercise problems.

EXERCISE FREQUENCY

To maintain or improve your condition, complete three workouts each week, with at least one day of rest between workouts. After a few months of regular exercise, you may complete up to five workouts each week, if desired. Remember, the key to success is to make exercise a regular and enjoyable part of your everyday life.

SUGGESTED STRETCHES

The correct form for several basic stretches is shown at the right. Move slowly as you stretch—never bounce.

1. Toe Touch Stretch

Stand with your knees bent slightly and slowly bend forward from your hips. Allow your back and shoulders to relax as you reach down toward your toes as far as possible. Hold for 15 counts, then relax. Repeat 3 times. Stretches: Hamstrings, back of knees and back.

2. Hamstring Stretch

Sit with one leg extended. Bring the sole of the opposite foot toward you and rest it against the inner thigh of your extended leg. Reach toward your toes as far as possible. Hold for 15 counts, then relax. Repeat 3 times for each leg. Stretches: Hamstrings, lower back and groin.

3. Calf/Achilles Stretch

With one leg in front of the other, reach forward and place your hands against a wall. Keep your back leg straight and your back foot flat on the floor. Bend your front leg, lean forward and move your hips toward the wall. Hold for 15 counts, then relax. Repeat 3 times for each leg. To cause further stretching of the achilles tendons, bend your back leg as well. Stretches: Calves, achilles tendons and ankles.

4. Quadriceps Stretch

With one hand against a wall for balance, reach back and grasp one foot with your other hand. Bring your heel as close to your buttocks as possible. Hold for 15 counts, then relax. Repeat 3 times for each leg. Stretches: Quadriceps and hip muscles.

5. Inner Thigh Stretch

Sit with the soles of your feet together and your knees outward. Pull your feet toward your groin area as far as possible. Hold for 15 counts, then relax. Repeat 3 times. Stretches: Quadriceps and hip muscles.

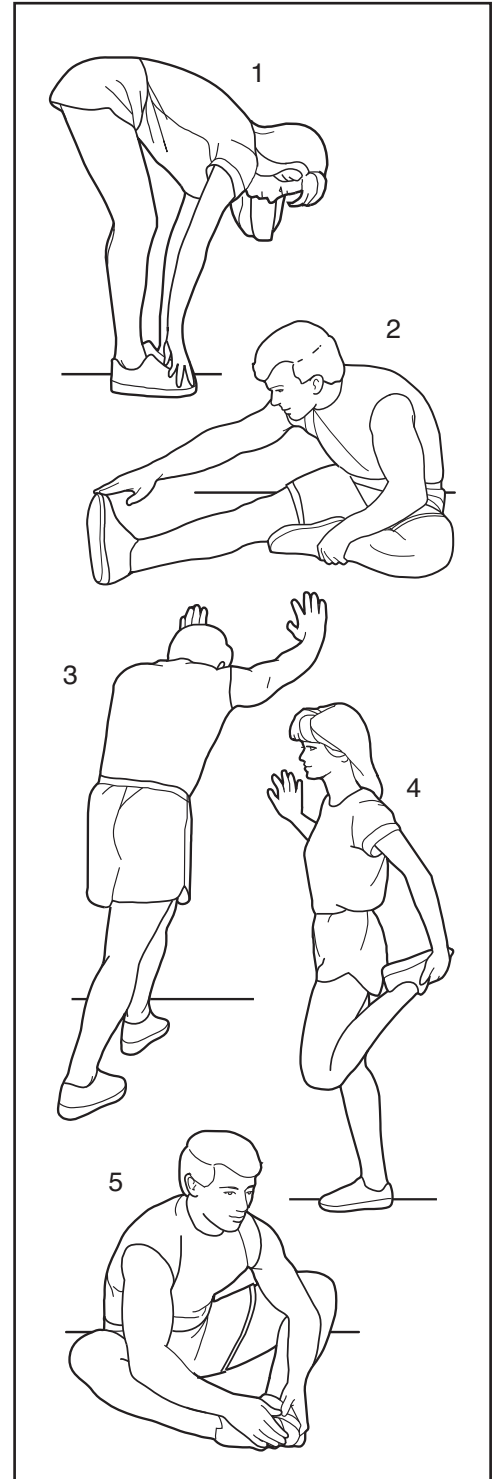

PART LIST

Model No. PFTL16010.0 R1210A

To locate the parts listed below, see the EXPLODED DRAWING near the end of this manual.

Key No.	Qty.	Description	Key No.	Qty.	Description
1	50	#8 x 3/4" Screw	51	2	Belt Guide
2	6	3/8" x 1 1/4" Bolt	52	2	Isolator
3	1	3/8" x 1 3/4" Bolt	53	1	Reed Switch
4	1	3/8" x 2" Bolt	54	2	Hood Mount
5	4	3/8" x 3 3/4" Bolt	55	2	Lift Arm Spacer
6	10	3/8" Star Washer	56	2	Lift Arm
7	8	3/8" Jam Nut	57	2	Incline Rod Spacer
8	2	Handrail Cap	58	1	Magnet
9	2	#8 x 1/2" Ground Screw	59	1	Drive Roller/Pulley
10	2	Drive Motor Bolt	60	1	Electronics Bracket
11	1	3/8" x 1 3/4" Hex Head Bolt	61	1	Controller
12	16	#8 x 3/4" Flat Head Screw	62	1	Front Cap
13	1	3/8" x 2" Hex Head Bolt	63	1	Power Switch
14	4	#8 Belt Guide Screw	64	2	Upright Wire Grommet
15	2	1/4" x 2 1/2" Bolt	65	1	Power Cord Grommet
16	6	#8 x 1/2" Screw	66	1	Power Cord
17	2	1/4" x 1 1/4" Bolt	67	1	Frame
18	2	5/16" x 1 1/4" Bolt	68	1	Walking Belt
19	12	#12 x 1" Screw	69	1	Idler Roller
20	2	3/8" x 3/4" Bolt	70	1	Hex Key
21	2	3/8" x 1 3/4" Flat Head Bolt	71	1	5/32" Hex Key
22	2	3/8" x 2 3/8" Bolt	72	1	Rear Foot Insert
23	5	#8 x 1/2" Washer Head Screw	73	1	Reed Switch Clamp
24	15	#8 x 3/4" Tek Screw	74	1	Incline Sensor Wire
25	4	#8 x 1" Screw	75	1	Motor Hood
26	8	#8 x 3/4" Pan Head Tek Screw	76	1	Incline Rod
27	1	Console	77	1	Incline Motor
28	4	#8 Star Washer	78	1	Incline Motor Wire
29	4	#8 x 1" Tek Screw	79	1	Stop Bracket
30	4	1/4" Star Washer	80	1	Stop Bracket Spacer
31	1	Right Pulse Grip	81	1	Drive Motor Belt
32	1	Handrail	82	1	Drive Motor
33	4	Base Foot Spacer	83	1	Left Rail Cover
34	4	1/4" Locknut	84	1	Left Foot Rail
35	1	#8 Locknut	85	1	Right Rail Cover
36	1	Access Door	86	1	Audio Wire
37	4	Hood Clip	87	1	Storage Latch
38	2	5/16" Flange Nut	88	1	Console Wire
39	1	Left Pulse Grip	89	1	Left Upright Sleeve
40	4	Handrail Grip Fastener	90	1	Right Upright Sleeve
41	1	Left Foot Insert	91	1	Left Upright
42	2	Rear Wheel Axle	92	1	Right Upright
43	4	Rear Wheel	93	1	Upright Wire
44	4	Caution Decal	94	1	Key/Clip
45	1	Right Foot Insert	95	1	Right Foot Rail
46	1	Rear Foot	96	2	Handrail Grip
47	2	Platform Cushion	97	6	Releasable Tie
48	2	Cushion Track	98	2	Tie Clamp
49	1	Warning Decal	99	9	Plastic Tie
50	1	Walking Platform	100	1	Left Base Cover

Key No.	Qty.	Description	Key No.	Qty.	Description
101	2	Wheel	106	1	Console Base
102	1	Right Base Cover	107	2	Console Ground Wire
103	1	Base	108	1	Console Plate
104	2	Console Clamp	*	–	User's Manual
105	4	Base Foot			

Note: Specifications are subject to change without notice. For information about ordering replacement parts, see the back cover of this manual. *These parts are not illustrated.

EXPLODED DRAWING A

Model No. PFTL16010.0 R1210A

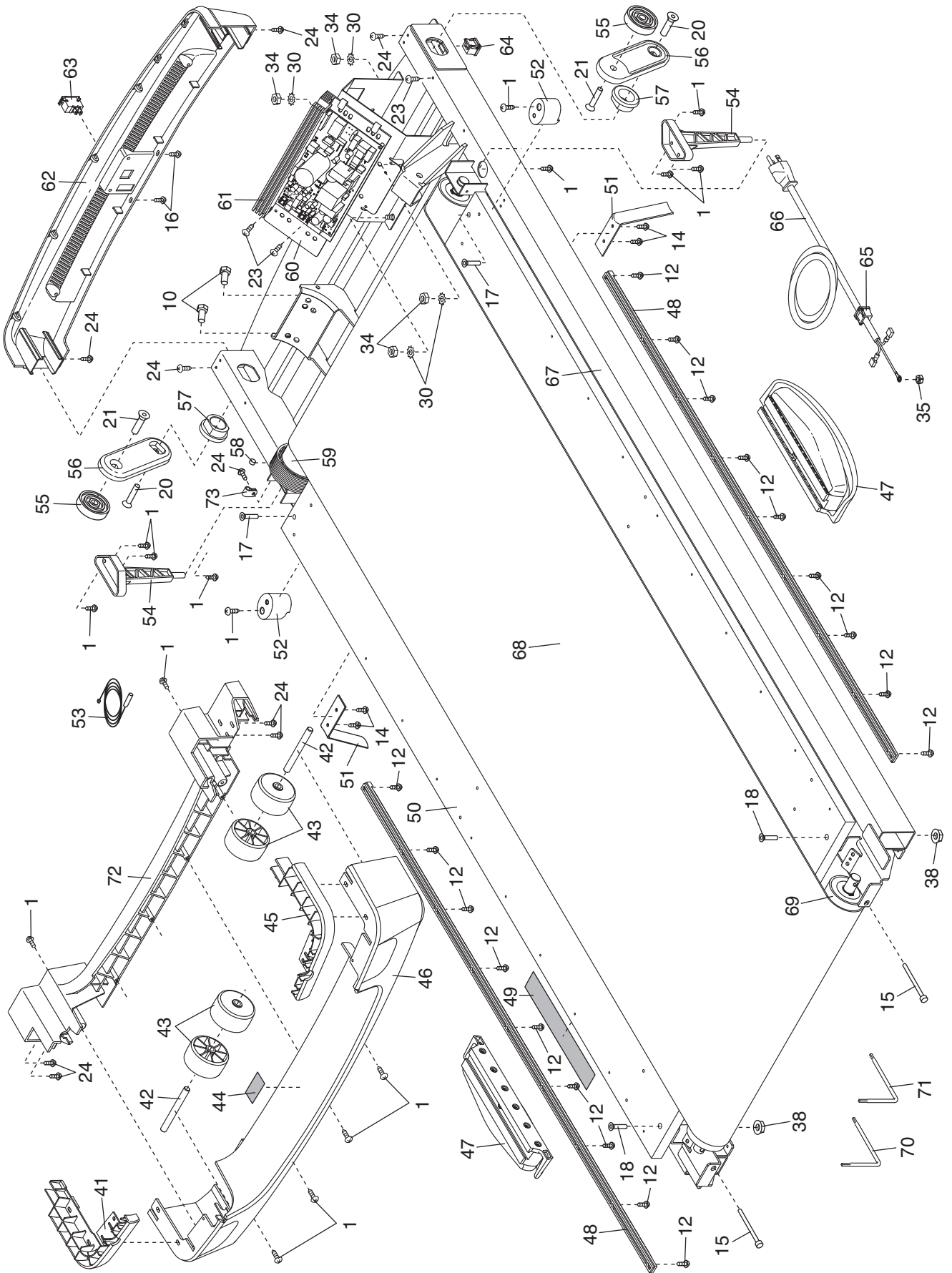

EXPLODED DRAWING B

Model No. PFTL16010.0 R1210A

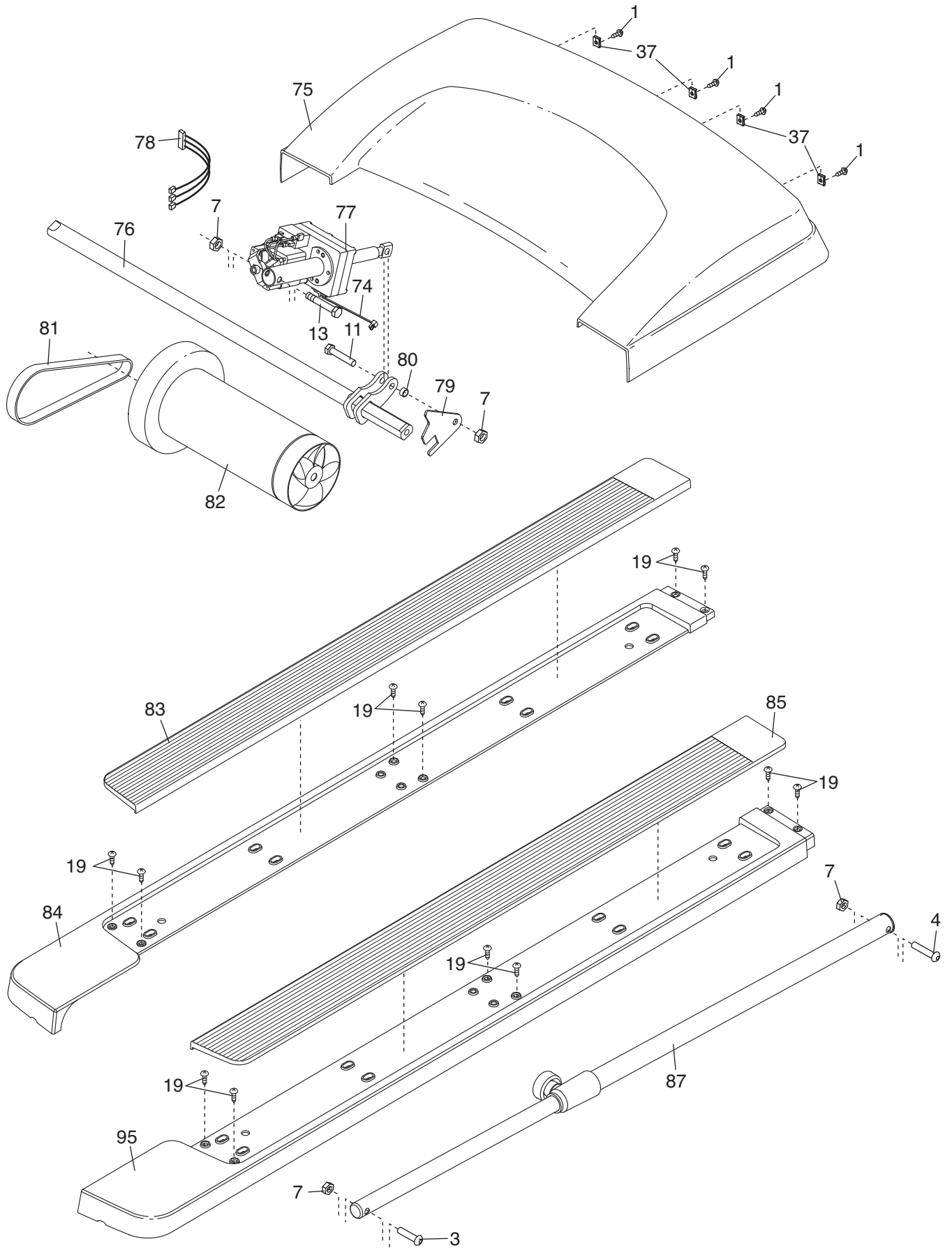

EXPLODED DRAWING C

Model No. PFTL16010.0 R1210A

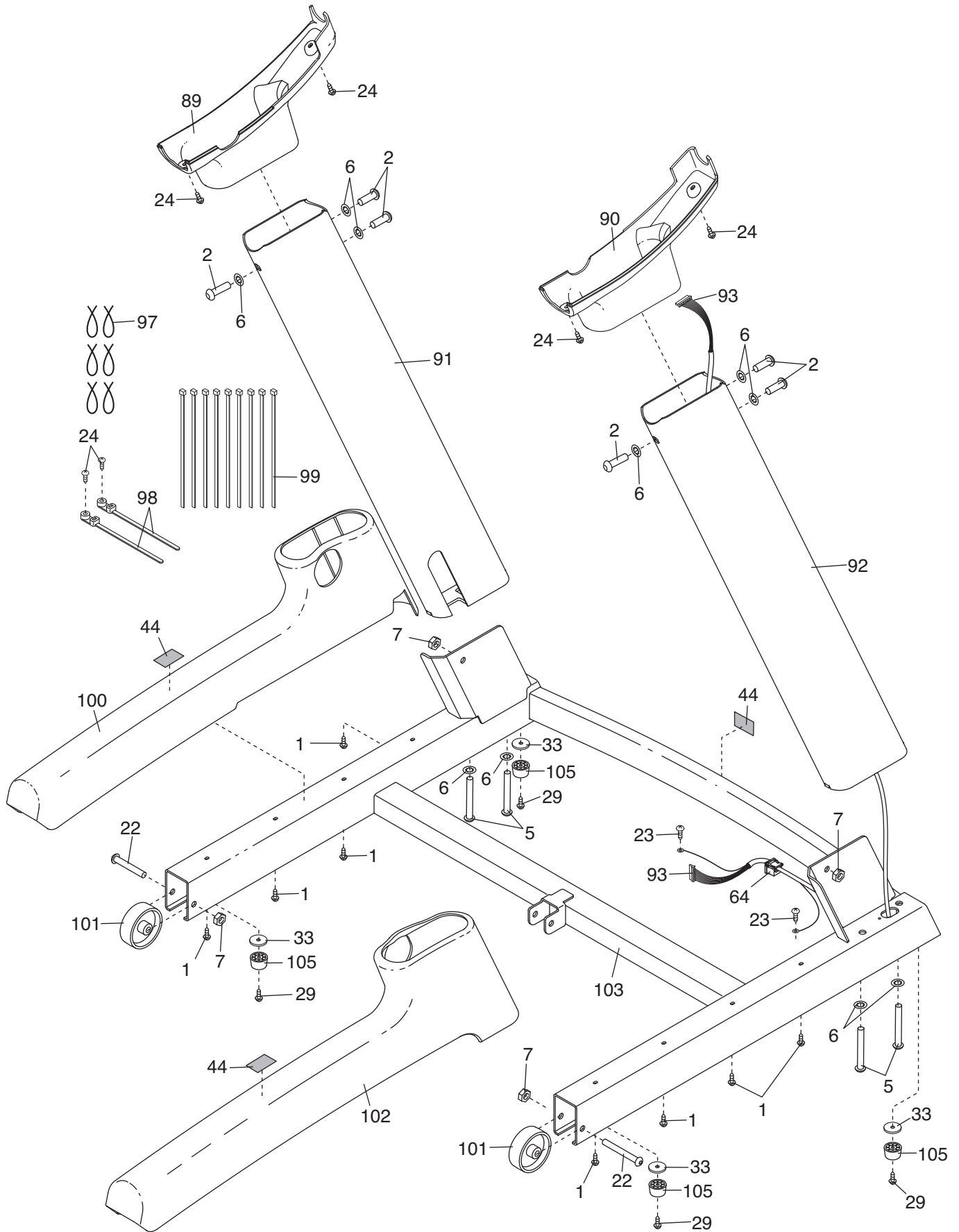

EXPLODED DRAWING D

Model No. PFTL16010.0 R1210A

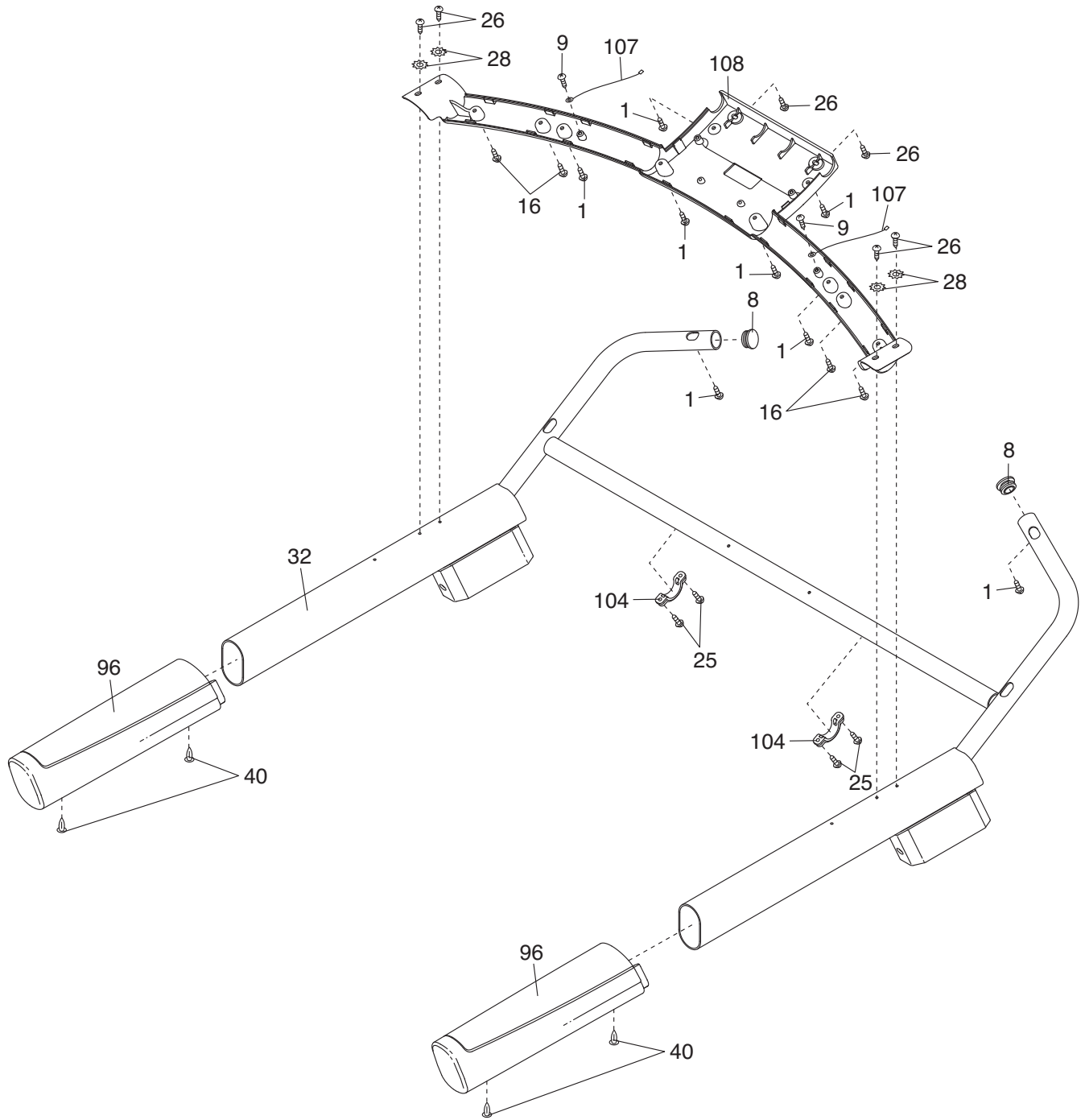

EXPLODED DRAWING E

Model No. PFTL16010.0 R1210A

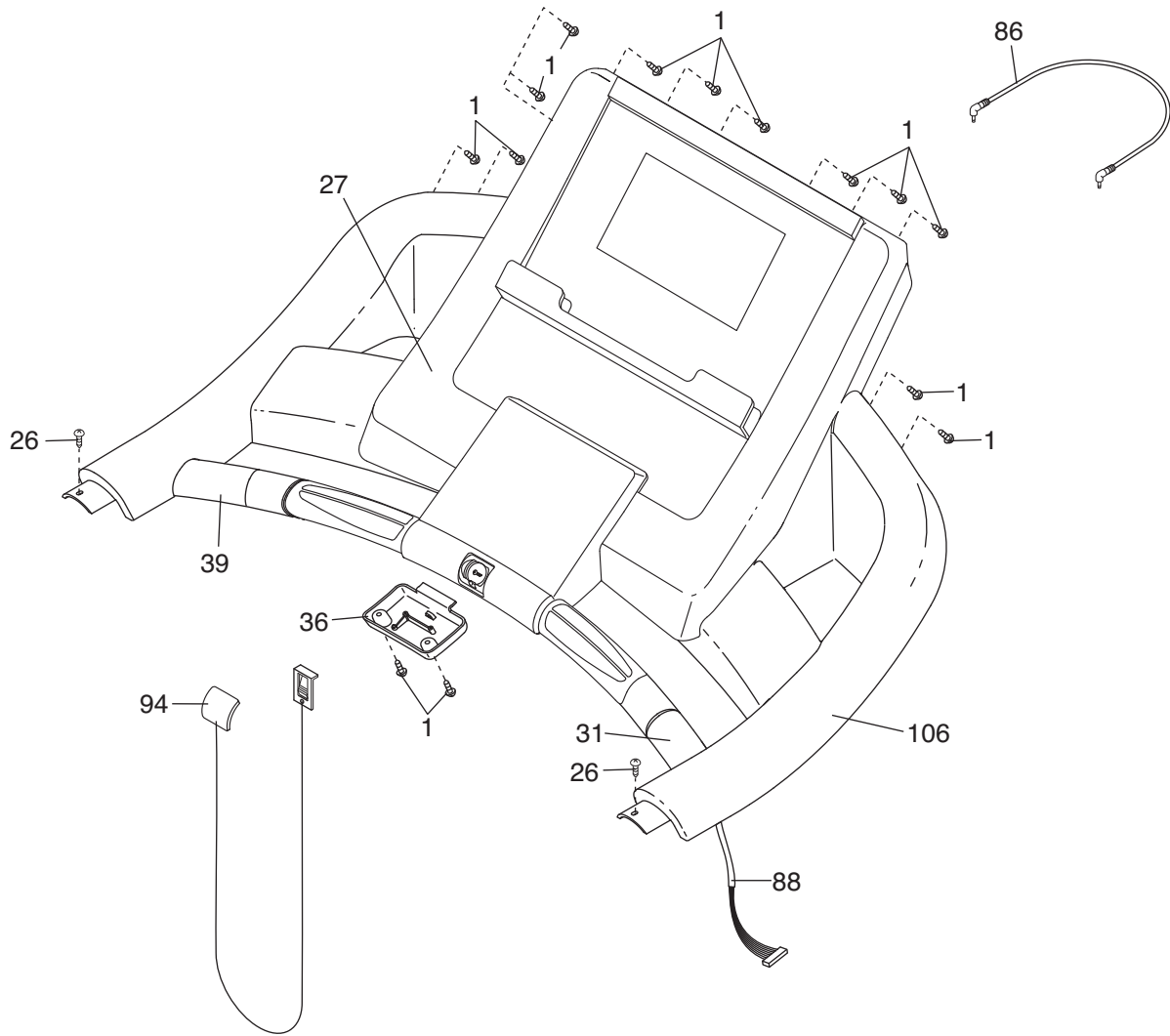

ORDERING REPLACEMENT PARTS

To order replacement parts, please see the front cover of this manual. To help us assist you, be prepared to provide the following information when contacting us:

- the model number and serial number of the product (see the front cover of this manual)
- the name of the product (see the front cover of this manual)
- the key number and description of the replacement part(s) (see the PART LIST and the EXPLODED DRAWING near the end of this manual)

LIMITED WARRANTY

IMPORTANT: You must register this product within 30 days of the purchase date to avoid added fees for service needed under warranty. Go to www.proformservice.com/registration.

ICON Health & Fitness, Inc. (ICON) warrants this product to be free from defects in workmanship and material, under normal use and service conditions. The frame and drive motor are warranted for a lifetime. Parts are warranted for five (5) years from the date of purchase. Labor is warranted for two (2) years from the date of purchase.

This warranty extends only to the original purchaser. ICON's obligation under this warranty is limited to repairing or replacing, at ICON's option, the product through one of its authorized service centers. All repairs for which warranty claims are made must be preauthorized by ICON. If the product is shipped to a service center, freight charges to and from the service center will be the customer's responsibility. For replacement parts shipped while the product is under warranty, the customer will be responsible for a minimal handling charge. For in-home service, the customer will be responsible for a minimal trip charge. This warranty does not extend to any damage to a product caused by or attributable to freight damage, abuse, misuse, improper or abnormal usage, or repairs not provided by an ICON authorized service center; to products used for commercial or rental purposes or as store display models; or to products transported or purchased outside the US. No other warranty beyond that specifically set forth above is authorized by ICON.

ICON is not responsible or liable for indirect, special, or consequential damages arising out of or in connection with the use or performance of the product; damages with respect to any economic loss, loss of property, loss of revenues or profits, loss of enjoyment or use, or costs of removal or installation; or other consequential damages of whatsoever nature. Some states do not allow the exclusion or limitation of incidental or consequential damages. Accordingly, the above limitation may not apply to you.

The warranty extended hereunder is in lieu of any and all other warranties, and any implied warranties of merchantability or fitness for a particular purpose are limited in their scope and duration to the terms set forth herein. Some states do not allow limitations on how long an implied warranty lasts. Accordingly, the above limitation may not apply to you.

This warranty gives you specific legal rights. You may also have other rights that vary from state to state.

ICON Health & Fitness, Inc., 1500 S. 1000 W., Logan, UT 84321-9813

Free Manuals Download Website

<http://myh66.com>

<http://usermanuals.us>

<http://www.somanuals.com>

<http://www.4manuals.cc>

<http://www.manual-lib.com>

<http://www.404manual.com>

<http://www.luxmanual.com>

<http://aubethermostatmanual.com>

Golf course search by state

<http://golfingnear.com>

Email search by domain

<http://emailbydomain.com>

Auto manuals search

<http://auto.somanuals.com>

TV manuals search

<http://tv.somanuals.com>