

# PRO-FORM<sup>®</sup> J8li

MILLENNIUM DRIVE™

Model No. 831.297990  
Serial No. \_\_\_\_\_

Find the serial number in the location shown below. Write the serial number in the space above for reference.

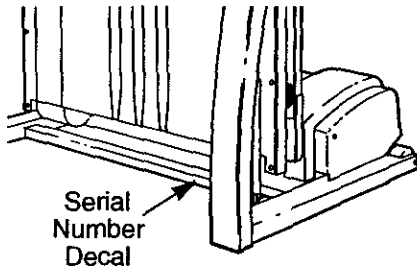

EXERCISE  
EQUIPMENT

QUESTIONS

HELPLINE!

1-800-736-6879

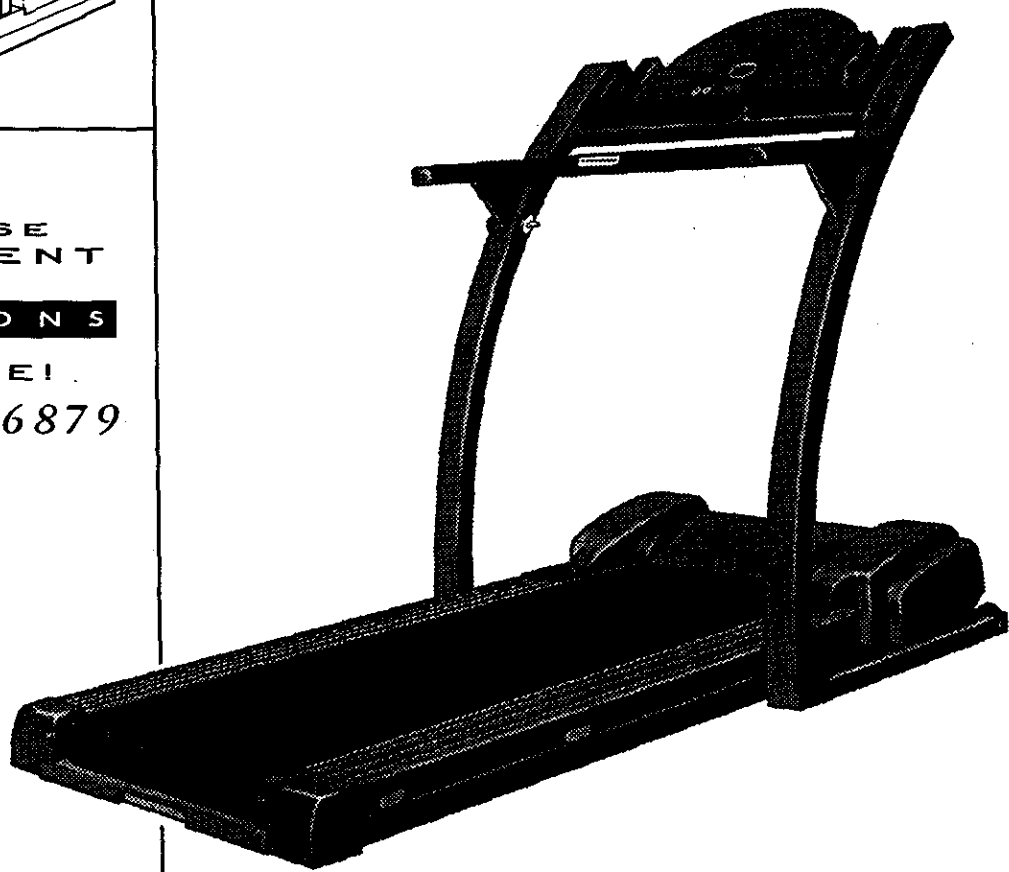

## CAUTION

Read all precautions and instructions in this manual before using this equipment. Save this manual for future reference.

## USER'S MANUAL

SEARS, ROEBUCK AND CO., HOFFMAN ESTATES, IL 60179

# PRO-FORM<sup>®</sup> J8li

MILLENNIUM DRIVE™

---

## TABLE OF CONTENTS

IMPORTANT PRECAUTIONS .....	3
BEFORE YOU BEGIN .....	5
ASSEMBLY .....	6
OPERATION AND ADJUSTMENT .....	7
HOW TO FOLD AND MOVE THE TREADMILL .....	15
MAINTENANCE AND TROUBLE-SHOOTING .....	17
CONDITIONING GUIDELINES .....	19
PART LIST .....	22
ORDERING REPLACEMENT PARTS .....	.Back Cover
FULL 90-DAY WARRANTY .....	.Back Cover

Note: An EXPLODED DRAWING is attached in the center of this manual.

# IMPORTANT PRECAUTIONS

**⚠ DANGER:** To reduce the risk of burns, fire, electric shock, or injury to persons, read the following important precautions and information before operating the treadmill.

1. It is the responsibility of the owner to ensure that all users of this treadmill are adequately informed of all warnings and precautions.
2. Use the treadmill only as described in this manual.
3. Place the treadmill on a level surface, with at least eight feet of clearance behind it. Do not place the treadmill on any surface that blocks air openings. To protect the floor or carpet from damage, place a mat under the treadmill.
4. Keep the treadmill indoors, away from moisture and dust. Do not put the treadmill in a garage or covered patio, or near water.
5. Do not operate the treadmill where aerosol products are used or where oxygen is being administered.
6. Keep children under the age of 12 and pets away from the treadmill at all times.
7. The treadmill should not be used by persons weighing more than 250 pounds.
8. Never allow more than one person on the treadmill at a time.
9. Wear appropriate exercise clothing when using the treadmill. Do not wear loose clothing that could become caught in the treadmill. Athletic support clothes are recommended for both men and women. *Always wear athletic shoes. Never use the treadmill with bare feet, wearing only stockings, or in sandals.*
10. When connecting the power cord (see page 7), plug the power cord into a surge protector (not included) and plug the surge protector into a grounded circuit capable of carrying 15 or more amps. No other appliance should be on the same circuit. Do not use an extension cord.
11. Use only a single-outlet surge suppressor that is UL 1449 listed as a transient voltage surge suppressor (TVSS). The surge suppressor must have a UL suppressed voltage rating of 400 volts or less and a minimum surge dissipation of 450 joules. The surge suppressor must be electrically rated for 120 volts AC and 15 amps.
12. Keep the power cord and the surge suppressor away from heated surfaces.
13. Never move the walking belt while the power is turned off. Do not operate the treadmill if the power cord or plug is damaged, or if the treadmill is not working properly. (See **BEFORE YOU BEGIN** on page 5 if the treadmill is not working properly.)
14. Never start the treadmill while you are standing on the walking belt.
15. Always hold the handrails while running on the treadmill. When walking, hold the handrails or use the included hand weights.
16. Do not perform exercises with the hand weights at speeds higher than a walk. Using weights and not holding the handrails may compromise your ability to maintain your balance. Exercises using weights should be attempted only by experienced users.
17. The treadmill is capable of high speeds. Adjust the speed in small increments to avoid sudden jumps in speed.
18. The pulse sensor is not a medical device. Various factors, including the user's movement, may affect the accuracy of heart rate readings. The pulse sensor is intended only as an exercise aid in determining heart rate trends in general.
19. To reduce the possibility of the treadmill overheating, do not operate the treadmill continuously for longer than one hour.
20. Never leave the treadmill unattended while it is running. Always remove the key, unplug the power cord and move the on/off switch to the off position when the treadmill is not in use. (See the drawing on page 5 for the location of the on/off switch.)

21. Do not attempt to raise, lower, or move the treadmill until it is properly assembled. (See **ASSEMBLY** on page 6, and **HOW TO MOVE THE TREADMILL** on page 15.) You must be able to safely lift 45 pounds (20 kg) in order to raise, lower, or move the treadmill.

22. Do not change the incline of the treadmill by placing objects under the treadmill.

23. When folding or moving the treadmill, make sure that the storage latch is fully closed.

24. Inspect and tighten all parts of the treadmill regularly.

25. Never drop or insert any object into any opening.

26. **DANGER:** Always unplug the power cord immediately after use, before cleaning the treadmill, and before performing the maintenance and adjustment procedures described in this manual. Never remove the motor hood unless instructed to do so by an authorized service representative. Servicing other than the procedures in this manual should be performed by an authorized service representative only.

27. This treadmill is intended for in-home use only. Do not use this treadmill in any commercial, rental, or institutional setting.

**⚠ WARNING:** Before beginning this or any exercise program, consult your physician. This is especially important for persons over the age of 35 or persons with pre-existing health problems. Read all instructions before using. SEARS assumes no responsibility for personal injury or property damage sustained by or through the use of this product.

## SAVE THESE INSTRUCTIONS

The decals shown at the right and below have been placed on your treadmill. If one of the decals is missing, or if it is not legible, please call our toll-free HELPLINE to order a free replacement decal (see the back cover of this manual). Apply the decal in the location shown.

### ⚠ WARNING

KEEP HANDS AND FEET AWAY FROM THIS AREA WHILE THE TREADMILL IS IN OPERATION.

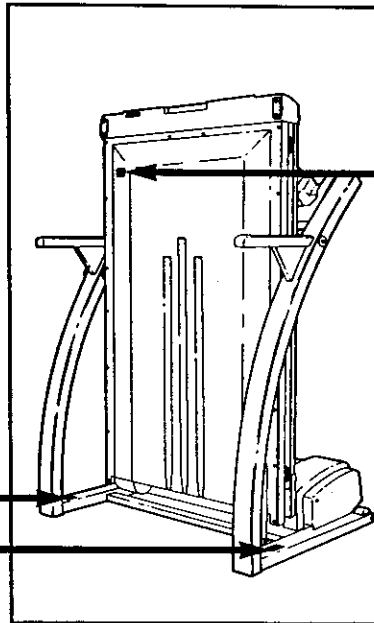

### ⚠ WARNING

- Never allow children on or around treadmill.
- Storage latch must be fully engaged before treadmill is moved or stored.

**IMPORTANT:** Incline must be at lowest level before folding treadmill into storage position.

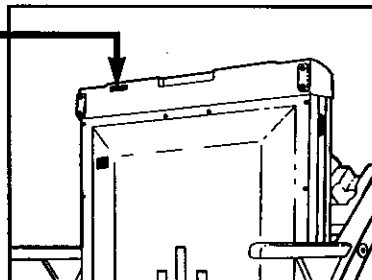

# BEFORE YOU BEGIN

Thank you for selecting the new PROFORM® J8li treadmill. The J8li treadmill combines advanced technology with innovative design to let you enjoy an excellent form of cardiovascular exercise in the convenience and privacy of your home. And when you're not exercising, the unique J8li can be folded up, requiring less than half the floor space of other treadmills.

**For your benefit, read this manual carefully before using the treadmill.** If you have additional questions, please call our toll-free HELPLINE at 1-800-736-6879,

Monday through Saturday, 7 a.m. until 7 p.m. Central Time (excluding holidays). To help us assist you, please note the product model number and serial number before calling. The model number of the treadmill is 831.297990. The serial number can be found on a decal attached to the treadmill (see the front cover of this manual for the location).

Before reading further, please review the drawing below and familiarize yourself with the parts that are labeled.

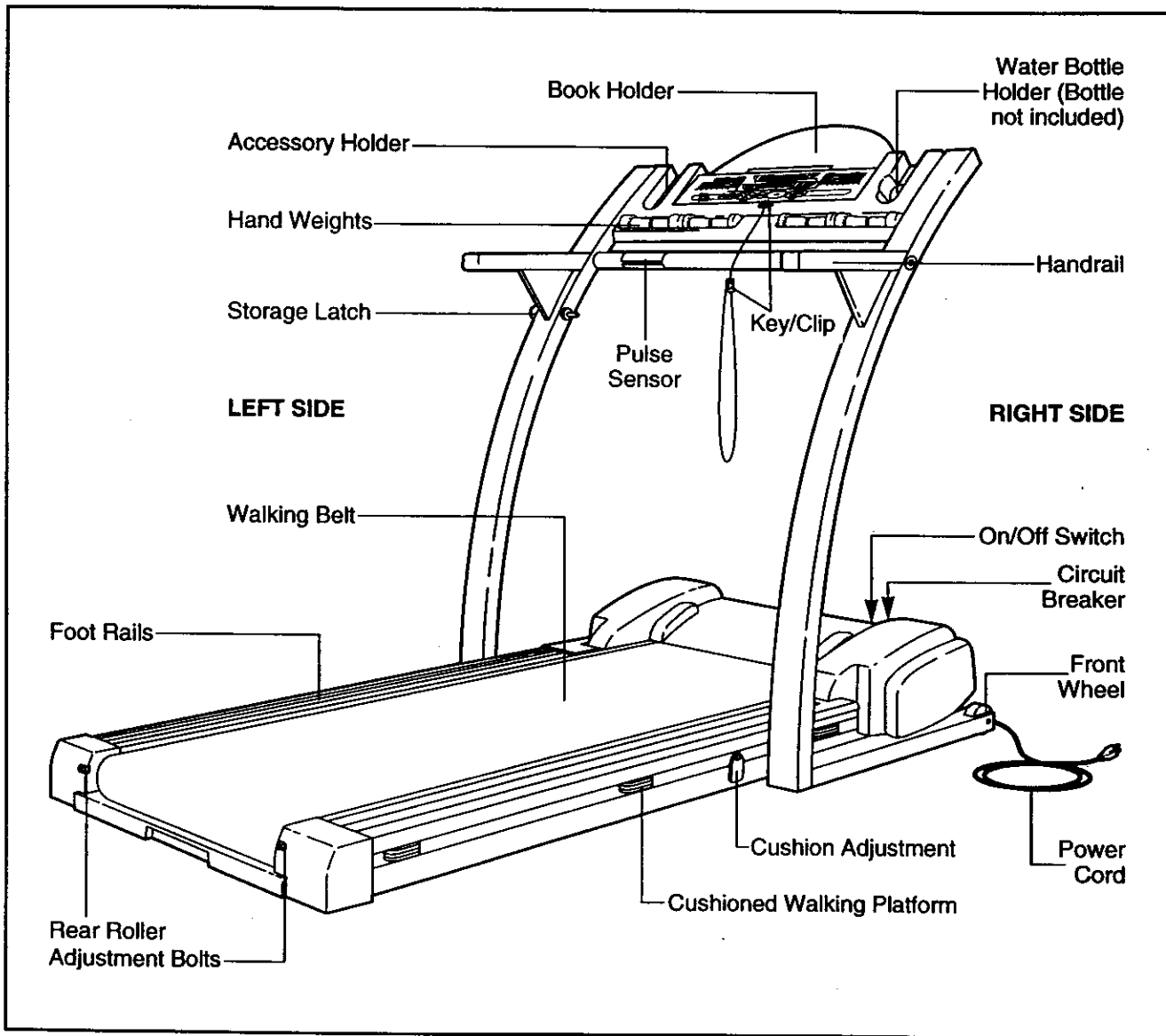

# ASSEMBLY

**Assembly requires two people.** Set the treadmill in a cleared area and remove all packing materials. Do not dispose of the packing materials until assembly is completed. **No tools are required for assembly.**

1. With the help of a second person, carefully raise the Uprights (15) until the treadmill is in the position shown.

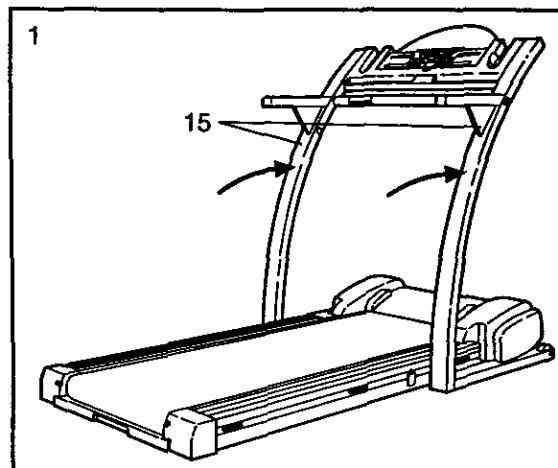

2. If the Handrail Grips (91) are not attached, slide a Handrail Grip onto the square tube on the left Upright (15). Attach the Handrail Grip with two Fasteners (63). Attach the other Handrail Grip (not shown) to the right Upright. Note: Extra Fasteners may be included.

If the Handrail Grips (91) do not touch the Uprights (15), squeeze the Handrail Grips and press them towards the Uprights repeatedly until the Handrail Grips touch the Uprights.

Next, make sure the Lock Knob Sleeve (93) is fully inserted into the left Upright (15). Remove the Lock Knob (92) from the Lock Pin (97). Make sure that the Lock Pin Collar (95) and the Spring (94) are on the Lock Pin. Insert the Lock Pin into the left Upright (15) and tighten the Lock Knob onto it.

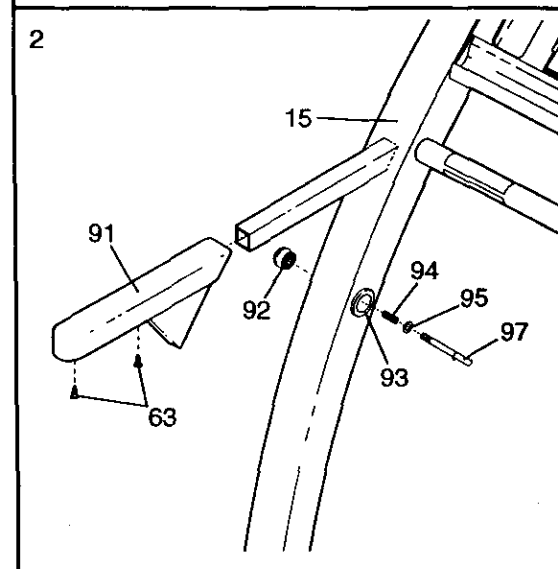

3. Remove the backing from the Adhesive Clip (29). Press the Adhesive Clip onto the base of one of the Uprights (15). Press the Allen Wrench (24) into the Adhesive Clip.

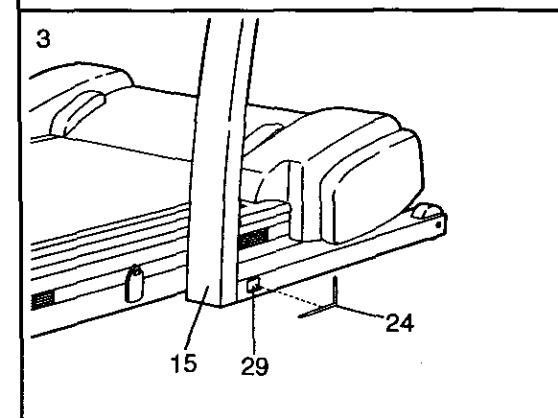

4. Make sure that all parts are tightened before you use the treadmill. Place a mat under the treadmill to protect the floor or carpet.

# OPERATION AND ADJUSTMENT

## THE PERFORMANT LUBE™ WALKING BELT

Your treadmill features a walking belt coated with PERFORMANT LUBE™, a high-performance lubricant. **IMPORTANT: Never apply silicone spray or other substances to the walking belt or the walking platform. Such substances will deteriorate the walking belt and cause excessive wear.**

## HOW TO PLUG IN THE POWER CORD

**⚠ DANGER:** Improper connection of the equipment-grounding conductor can result in an increased risk of electric shock. Check with a qualified electrician or serviceman if you are in doubt as to whether the product is properly grounded. Do not modify the plug provided with the product—if it will not fit the outlet, have a proper outlet installed by a qualified electrician.

Your treadmill, like any other type of sophisticated electronic equipment, can be seriously damaged by sudden voltage changes in your home's power. Voltage surges, spikes, and noise interference can result from weather conditions or from other appliances being turned on or off. **To decrease the possibility of your treadmill being damaged, always use a surge suppressor with your treadmill (see drawing 1 at the right).**

Surge suppressors are sold at most hardware stores and department stores. Use only a single-outlet surge suppressor that is UL 1449 listed as a transient voltage surge suppressor (TVSS). The surge suppressor must have a UL suppressed voltage rating of 400 volts or less and a minimum surge dissipation of 450 joules. The surge suppressor must be electrically rated for 120 volts AC and 15 amps.

**This product must be grounded.** If it should malfunction or break down, grounding provides a path of least resistance for electric current to reduce the risk of electric shock. This product is equipped with a cord having an equipment-grounding conductor and a grounding plug. **Plug the power cord into a surge suppressor, and plug the surge suppressor into an appropriate outlet that is properly installed and grounded in accordance with all local codes and ordinances.**

This product is for use on a nominal 120-volt circuit, and has a grounding plug that looks like the plug illustrated in drawing 1 below. A temporary adapter that looks like the adapter illustrated in drawing 2 may be used to connect the surge suppressor to a 2-pole receptacle as shown in drawing 2 if a properly grounded outlet is not available.

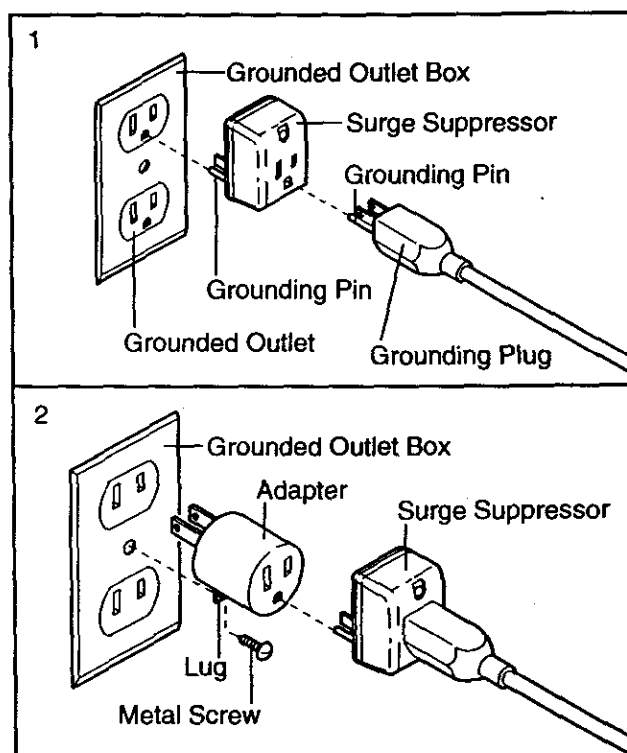

The temporary adapter should be used only until a properly grounded outlet (drawing 1) can be installed by a qualified electrician.

The green-colored rigid ear, lug, or the like extending from the adapter must be connected to a permanent ground such as a properly grounded outlet box cover. Whenever the adapter is used it must be held in place by a metal screw. **Some 2-pole receptacle outlet box covers are not grounded. Contact a qualified electrician to determine if the outlet box cover is grounded before using an adapter.**

## CONSOLE DIAGRAM

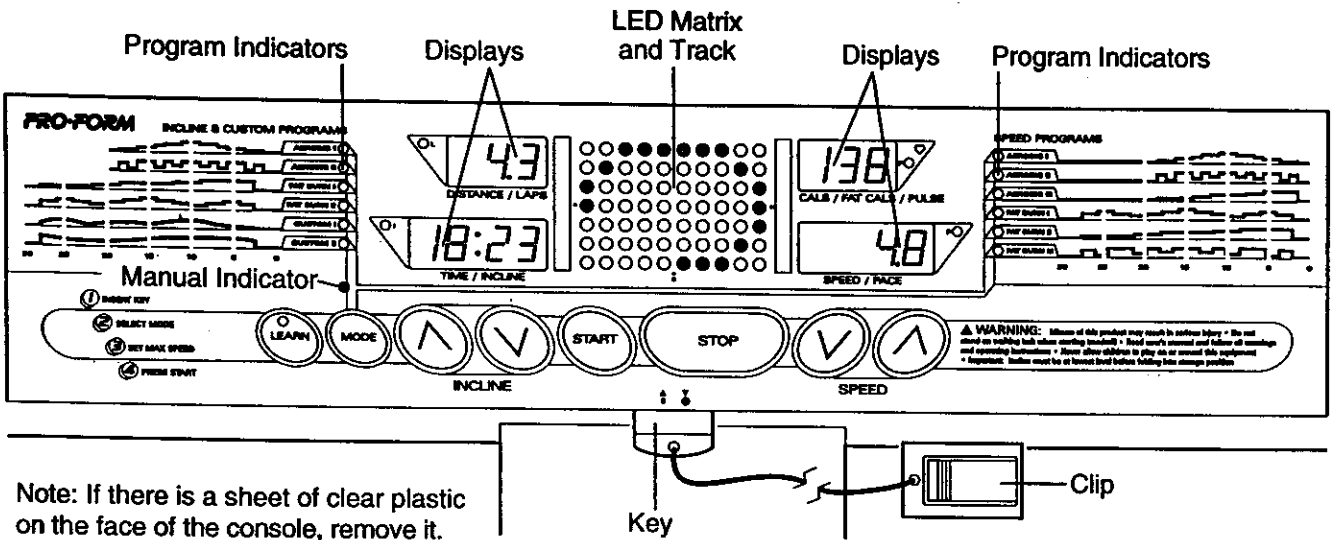

**CAUTION:** Before operating the console, read the following precautions.

- Do not stand on the walking belt when turning on the power.
- Always wear the clip (see the drawing above) while operating the treadmill. If the key is pulled from the console, the walking belt will automatically stop.
- Adjust the speed in small increments to avoid sudden jumps in speed.
- To reduce the possibility of electric shock, keep the console dry. Avoid spilling liquids on the console, and place only a sealed water bottle in the water bottle holder.

### FEATURES OF THE CONSOLE

The treadmill console offers an impressive array of features to help you get the most from your workouts. When the manual mode is selected, the speed and incline of the treadmill can be changed with a touch of a button. As you exercise, the LED track and four displays will provide continuous exercise feedback. With the built-in pulse sensor, you can even measure your heart rate.

In addition, the console offers ten workout programs. Four programs automatically control the incline of the

treadmill and six programs control the speed of the treadmill as they guide you through effective workouts. You can even create custom workout programs and save them in the console's memory for future use.

An optional chest pulse sensor adds even more features to the console. The chest pulse sensor continuously monitors your heart rate during your workouts and offers hands-free operation. To purchase an optional chest pulse sensor, refer to page 14.

### STEP-BY-STEP CONSOLE OPERATION

Note: The treadmill console can display speed and distance in either miles or kilometers (see SPEED/PACE DISPLAY on page 9). For simplicity, all instructions in this section refer to miles.

To operate the console, first make sure that the on/off switch, located near the power cord, is in the on position.

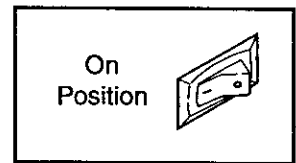

Next, plug in the power cord (see HOW TO PLUG IN THE POWER CORD on page 7).

Step onto the foot rails of the treadmill. Find the clip attached to the key (see the drawing above), and slide the clip onto the waistband of your clothing. Follow the instructions on pages 9 to 13 to operate the console.



## HOW TO USE THE MANUAL MODE

### 1 Insert the key into the console.

A moment after the key is inserted, the four displays, the LED track, and various indicators will light.

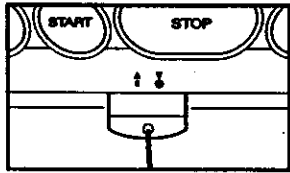

### 2 Select the manual mode.

When the key is inserted, the manual mode will be selected, as shown by the manual indicator. If you have selected a workout program, press the mode button repeatedly until the manual indicator lights.

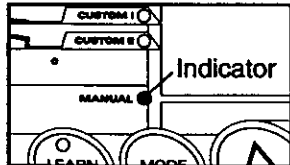

### 3 Press the START button and adjust the speed of the walking belt.

A moment after the START button is pressed, the walking belt will begin to move. Hold the handrails and carefully begin walking.

As you exercise, change the speed of the walking belt as desired by pressing the SPEED buttons. Each time one of the buttons is pressed, the speed will change by 0.1 mph. The buttons can be held down to change the speed setting quickly. Note: It may take a few seconds for the walking belt to reach the selected speed setting.

To stop the walking belt, press the STOP button. The TIME/INCLINE display will begin to flash. To restart the walking belt, press the START button again. To stop the walking belt and reset the displays, hold down the STOP button for two seconds.

### 4 Adjust the incline of the treadmill as desired

To change the incline of the treadmill, press the INCLINE buttons. Each time one of the buttons is pressed, the incline will change by 0.5%. The buttons can be held down to change the incline quickly. Note: It may take a few seconds for the treadmill to reach the selected incline setting.

### 5 Follow your progress with the LED track and the four displays.

**The LED Track—**When the manual mode is selected, the LED matrix will display a track. The track represents a distance of 1/4 mile. As you exercise, the indicators around the track will light one at a time until you have completed 1/4 mile. A new lap will then begin.

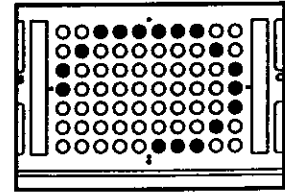

#### DISTANCE/LAPS

**display—**This display shows the distance that the walking belt has moved and the number of 1/4-mile laps you have completed. The display will alternate between one number and the other every seven seconds; the indicator will light when the number of laps is shown.

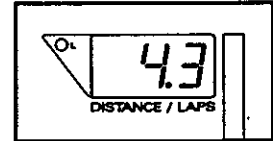

#### TIME/INCLINE

**display—**This display shows the elapsed time and the incline level of the treadmill. The display will alternate between one number and the other every seven seconds; the indicator will light when the incline is shown. Note: When a workout program is selected, the display will show the *time remaining* in the program.

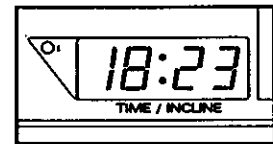

#### SPEED/PACE

**display—**This display shows the speed of the walking belt and your current pace (pace is measured in *minutes per mile*). Every seven seconds, the display will change from one number to the other; the indicator will light when your pace is shown.

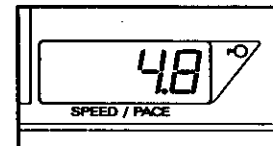

Note: The console can display distance, speed and pace in either miles or kilometers. To see which unit of measurement is selected, hold down the STOP button while inserting the key into the console. An "E," for english miles, or an "M," for metric kilometers, will appear in the CALS/FAT CALS/PULSE display. If you want to change the unit of measurement, press the SPEED  $\Delta$  button. Remove and then reinsert the key.

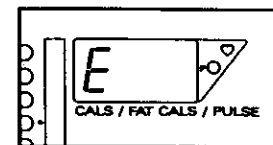

**CALS/FAT CALS/PULSE display**—This display shows the approximate numbers of *calories* and *fat calories* you have burned (see FAT BURNING on page 19). Every seven seconds, the display will change from one number to the other; the indicator will light when the number of fat calories is shown. This display will also show your heart rate when the pulse sensor is used (see step 6).

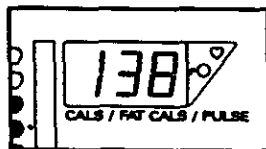

**6 Measure your heart rate, if desired.**

Stand on the foot rails and place your hands on the metal contacts on the handrail. Your palms must be resting on the upper contacts, and your fingers must be touching the lower contacts—

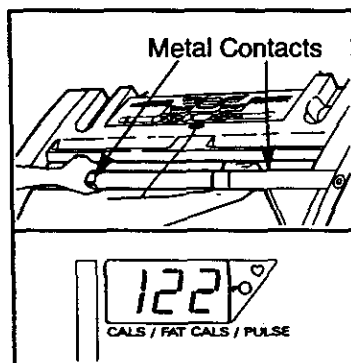

**avoid moving your hands.** When your heart rate is detected, the heart-shaped indicator in the CALS/FAT CALS/PULSE display will flash steadily and a "P" will appear. After a few seconds, your heart rate will be shown. **For the most accurate heart rate reading, continue to hold the contacts for about 15 seconds.**

**7 When you are finished exercising, press the STOP button and remove the key.**

Step onto the foot rails, press the STOP button and remove the key from the console. Keep the key in a secure place.

In addition, move the on/off switch to the off position and unplug the power cord.

**HOW TO USE THE WORKOUT PROGRAMS**

The four incline programs automatically control the incline of the treadmill as they guide you through effective workouts; the six speed programs automatically control the speed of the treadmill. Follow the steps below to use a workout program.

**1 Insert the key into the console.**

A moment after the key is inserted, the four displays, the LED track, and various indicators will light.

**2 Press the MODE button to select the desired workout program.**

When the key is inserted, the manual mode will be selected, as shown by the manual indicator.

To select one of the workout programs, press the mode button repeatedly until one of the four incline program indicators or one of the six speed program indicators lights.

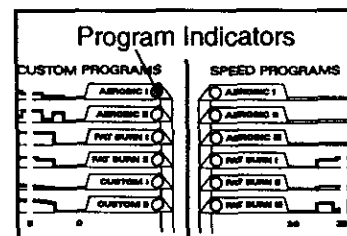

Note: The five AEROBIC programs are twenty minutes long; the five FAT BURN programs are thirty minutes long. The graphs on the sides of the console show how the incline or speed of the treadmill will change during the programs. During the AEROBIC I programs, for example, the incline or speed will gradually increase during the first ten minutes and then gradually decrease during the last ten minutes. Each program begins with a warm-up period and ends with a cool-down period.

**3 Set a maximum incline or speed setting.**

If you selected an incline program, a number will flash in the TIME/INCLINE display. This number is the *maximum incline* that the treadmill will reach during the selected program. If you want to change the maximum incline setting, press the INCLINE Δ button. The maximum incline setting can be from 4.5% to 10%. If the setting is increased, the difficulty level of the entire program will increase. If the setting is decreased, the difficulty level of the entire program will decrease.

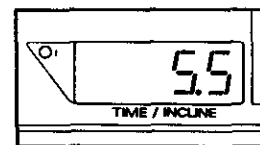

If you selected a speed program, a number will flash in the SPEED/PACE display. This number is the *maximum speed* that the walking belt will reach during the selected program. If you want to change the maximum speed setting, press the SPEED  $\Delta$  button. The maximum speed setting can be from 4 mph to 10 mph. If the setting is increased, the difficulty level of the entire program will increase. If the setting is decreased, the difficulty level of the entire program will decrease.

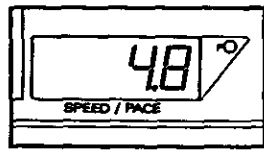

#### **4** Press the START button to start the program

A moment after the START button is pressed, the walking belt will begin to move. (If an incline program is selected, the treadmill will also adjust to the first incline setting of the program, unless it is already at the first setting.) Hold the handrails and carefully begin walking.

Each program consists of twenty or thirty one-minute periods. (The length of the program is shown in the TIME/INCLINE display.) If an incline program is selected, one incline setting is programmed for each period; if a speed program is selected, one speed setting is programmed for each period.

The incline or speed settings of the program you have selected will be shown in the LED matrix. The incline or speed setting of the first period will be shown in the flashing CURRENT PERIOD column. The settings of the next seven periods will be shown in the seven columns to the right.

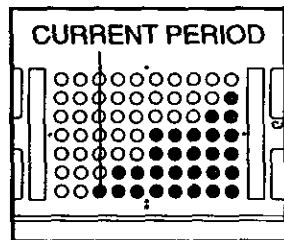

When only three seconds remain in the first one-minute period of the program, both the CURRENT PERIOD column and the column to the right will flash and three tones will sound. All incline or speed settings will then move one column to the left. The setting of the second period will then be shown in the CURRENT PERIOD column and the incline or speed of the treadmill will automatically adjust to that setting.

If an incline program is selected, the speed of the treadmill can be changed during the program with the SPEED buttons. If a speed program is selected, the incline of the treadmill can be changed with the INCLINE buttons.

The program will continue until the incline or speed setting of the last period is shown in the CURRENT PERIOD column of the LED matrix and the TIME/INCLINE display counts down to zero. The walking belt will then slow to a stop.

If the program is too easy or too difficult, the intensity of the program can be adjusted. If an incline program is selected, press the INCLINE buttons to adjust the maximum incline setting; if a speed program is selected, press the SPEED buttons to adjust the maximum speed setting (see step 3 on page 10).

To stop the program for a moment, press the STOP button. The displays will pause and the TIME/INCLINE display will begin to flash. To restart the program, press the START button. To end the program at any time, hold down the STOP button for two seconds. The MANUAL mode will then be selected.

#### **5** Follow your progress with the four displays.

See step 5 on page 9.

#### **6** Measure your heart rate, if desired.

See step 6 on page 10.

#### **7** When the program is completed, remove the key.

Step onto the foot rails and remove the key from the console. Keep the key in a secure place. In addition, move the on/off switch to the off position and unplug the power cord.

## HOW TO CREATE CUSTOM PROGRAMS

The Custom 1 and Custom 2 programs are workout programs that you create. The programs control both the speed and the incline of the treadmill, and can be up to 40 minutes long. The programs are stored in memory and can be changed as many times as desired. Follow the steps below to create a custom program.

### 1 Insert the key into the console.

A moment after the key is inserted, the four displays, the LED track and various indicators will light.

### 2 Press the MODE button to select a custom workout program.

When the key is inserted, the manual mode will be selected, as shown by the manual indicator.

To select a custom program, press the mode button repeatedly until one of the two custom program indicators lights.

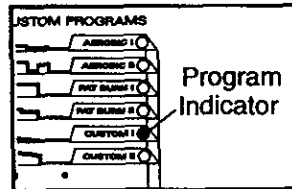

### 3 Press the START button to start the program.

A moment after the START button is pressed, the walking belt will begin to move. Hold the handrails and carefully begin walking.

### 4 Press the LEARN button and program the desired speed and incline settings.

When the LEARN button is pressed, the LEARN indicator will light. Speed and incline settings can be programmed only when the indicator is lit.

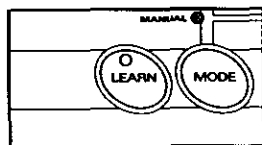

Each custom program is divided into one-minute periods. One speed setting and one incline setting can be programmed for each period. The speed setting of the first period is shown in the flashing CURRENT PERIOD column of the LED matrix. (The incline settings are not shown in the matrix.) To program speed and incline settings for the first period, simply

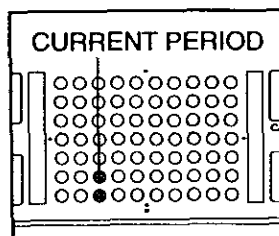

adjust the speed and incline of the treadmill to the desired levels with the SPEED and INCLINE buttons. Every few times the SPEED buttons are pressed, one additional indicator will light or darken in the CURRENT PERIOD column.

When the first period is completed, three tones will sound and the current speed and incline settings will be stored in memory. All settings shown in the LED matrix will then move one column to the left and the speed setting of the second period will be shown in the CURRENT PERIOD column. Program speed and incline settings for the second period as described above. Repeat this procedure until you have programmed speed and incline settings for as many periods as desired. Programs can have up to forty periods.

Note: To stop the program for a moment, press the STOP button. The displays will pause and the TIME/INCLINE display will begin to flash. To restart the program, press the START button.

### 5 When you are finished programming settings, hold down the STOP button for two seconds.

When you have programmed speed and incline settings for as many one-minute periods as desired, hold down the STOP button for two seconds. The speed and incline settings that you have programmed and the length of the program will be stored in memory. To use the program again, see HOW TO USE CUSTOM PROGRAMS below.

### 6 When the program is completed, remove the key.

Step onto the foot rails and remove the key from the console. Keep the key in a secure place. In addition, move the on/off switch to the off position and unplug the power cord.

## HOW TO USE CUSTOM PROGRAMS

### 1 Insert the key into the console.

A moment after the key is inserted, the four displays, the LED track and various indicators will light.

### 2 Press the MODE button to select a custom workout program.

When the key is inserted, the manual mode will be selected, as shown by the manual indicator.

To select a custom program, press the mode button repeatedly until one of the two custom program indicators lights.

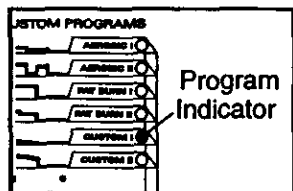

**3** Press the START button to start the program.

A moment after the button is pressed, the walking belt will begin to move. Hold the handrails and carefully begin walking.

Each program is divided into one-minute periods. One speed setting and one incline setting are programmed for each period. The speed setting of the first period is shown in the flashing CURRENT PERIOD column of the LED matrix. (The incline settings are not shown in the matrix.)

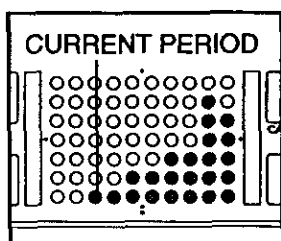

When only three seconds remain in the first period, both the CURRENT PERIOD column and the column to the right will flash and three tones will sound. All speed settings will then move one column to the left. The speed setting of the second period will then be shown in the CURRENT PERIOD column and the speed and incline of the treadmill will adjust to the second settings that you programmed previously.

The program will continue until the speed setting of the last period is shown in the CURRENT PERIOD column of the LED matrix and the TIME/INCLINE display counts down to zero. The walking belt will then slow to a stop.

During the program, the speed and incline settings of the current period can be adjusted with the SPEED and INCLINE buttons. Adjustments will not be stored in memory. To **reprogram** speed and incline settings, press the LEARN button. The LEARN indicator will light. **Speed and incline settings can be reprogrammed only when the indicator is lit.** Next, adjust the speed and incline of the treadmill with the SPEED and INCLINE buttons. *When the current period of the program is completed, the new speed and incline settings will be stored in memory. When you have reprogrammed speed and incline settings for as many periods as desired, press the LEARN button again.*

To stop the program for a moment, press the STOP button. The displays will pause and the TIME/INCLINE display will begin to flash. To restart the program, press the START button. To end the program at any time, hold down the STOP button for two seconds. The MANUAL mode will then be selected.

**4** Follow your progress with the LED displays.

Refer to step 6 on page 11.

**5** Measure your heart rate, if desired.

See step 6 on page 10.

**6** When the program is completed, remove the key.

Step onto the foot rails and remove the key from the console. Keep the key in a secure place. In addition, move the on/off switch to the off position and unplug the power cord.

**THE INFORMATION MODE**

To access the information mode, hold down the STOP button while inserting the key into the console.

The DISTANCE/LAPS display will show the total number of miles that the walking belt has moved.

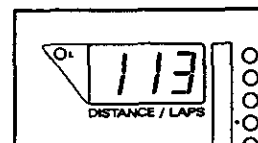

The TIME/INCLINE display will show the total number of hours that the treadmill has been used.

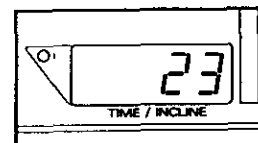

An "E," for english miles, or an "M," for metric kilometers, will appear in the CALS/FAT CALS/PULSE display. If you want to change the unit of measurement, press the SPEED Δ button.

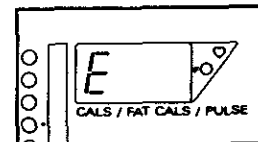

To exit the information mode, remove the key from the console.

## HOW TO ADJUST THE FIRMNESS OF THE WALKING PLATFORM

The walking platform is specially designed to cushion the impact as you walk or run on the treadmill. The firmness of the walking platform can be adjusted to any of three settings using the control on the right side of the treadmill. For a firmer walking platform, turn the control clockwise. For a softer walking platform, turn the control counterclockwise. **If it is difficult to turn the control, lift up on the walking platform while turning the control.** Note: The faster you run on the treadmill, the firmer the walking platform should be. If the walking platform is too soft, the treadmill may bounce excessively.

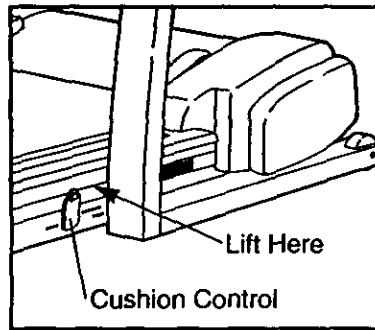

## HOW TO USE THE HAND WEIGHTS

The included hand weights let you add upper body exercise to your workouts. As you walk on the treadmill, hold the 2-pound weights at your sides or press the weights above your head. To increase the intensity of your exercise, use the 3-pound weights.

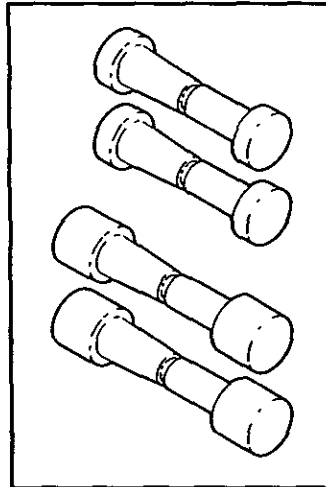

**WARNING: Do not use the hand weights at speeds higher than a walk.**

**Using weights and not holding the handrails may compromise your ability to maintain your balance. Exercises using weights should be attempted only by experienced users.**

The hand weights can be stored in the handy weight rack on the console.

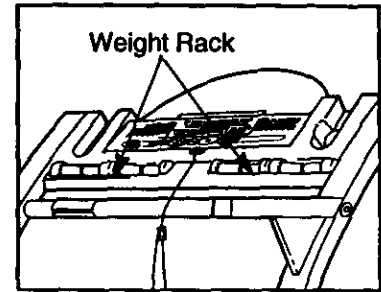

## THE OPTIONAL CHEST PULSE SENSOR

An optional chest pulse sensor adds even more features to the console. The chest pulse sensor offers hands-free operation and continuously monitors your heart rate during your workouts. **To purchase the optional chest pulse sensor, please see the back cover of this manual.**

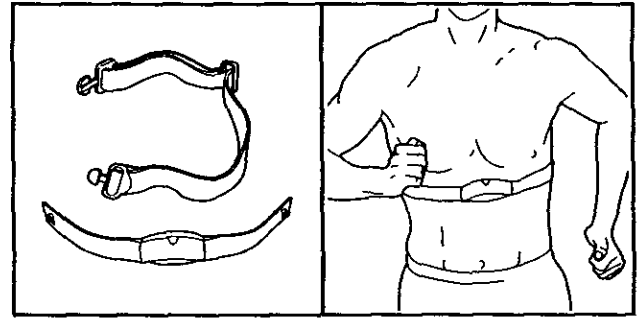

# HOW TO FOLD AND MOVE THE TREADMILL

## HOW TO FOLD THE TREADMILL FOR STORAGE

Before folding the treadmill, adjust the incline to the lowest position. If this is not done, the treadmill may be permanently damaged. Next, unplug the power cord. **CAUTION:** You must be able to safely lift 45 pounds (20 kg) in order to raise, lower, or move the treadmill.

1. Hold the treadmill with your hands in the locations shown at the right. **CAUTION:** To decrease the possibility of injury, bend your legs and keep your back straight. As you raise the treadmill, make sure to lift with your legs rather than your back. Raise the treadmill about halfway to the vertical position.

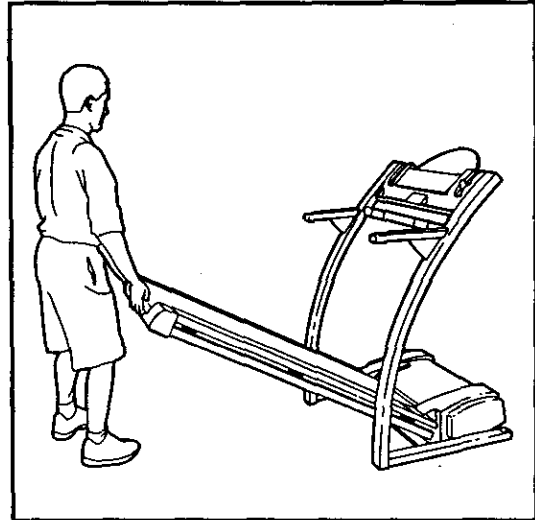

2. Move your right hand to the position shown and hold the treadmill firmly. Using your left hand, pull the latch knob to the left and hold it. Raise the treadmill until the latch pin is aligned with the hole in the catch. Insert the latch pin into the catch. Make sure that the latch pin is fully inserted into the catch.

To protect the floor or carpet from damage, place a mat under the treadmill. Keep the treadmill out of direct sunlight. Do not leave the treadmill in the storage position in temperatures above 85° Fahrenheit.

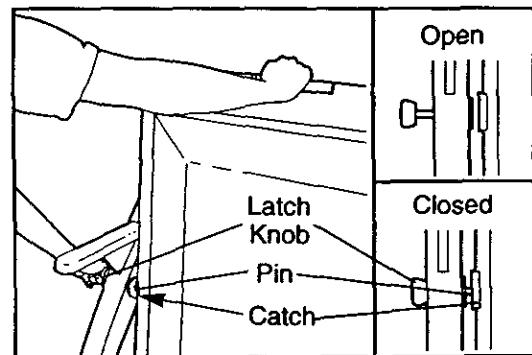

## HOW TO MOVE THE TREADMILL

Before moving the treadmill, convert the treadmill to the storage position as described above. Make sure that the latch pin is fully inserted into the catch.

1. Hold the handrails as shown and place one foot against a wheel. Do not hold or push on the book holder or the book holder may be damaged.
2. Tilt the treadmill back until it rolls freely on the front wheels. Carefully move the treadmill to the desired location. Never move the treadmill without tipping it back. To reduce the risk of injury, use extreme caution while moving the treadmill. Do not attempt to move the treadmill over an uneven surface.
3. Place one foot on the base, and carefully lower the treadmill until it is resting in the storage position.

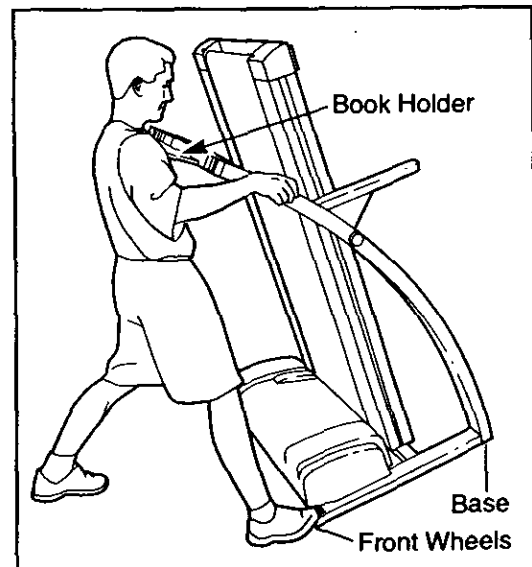

## HOW TO LOWER THE TREADMILL FOR USE

1. Hold the upper end of the treadmill with your right hand as shown. Using your left hand, pull the latch knob to the left and hold it. Pivot the treadmill down until the frame is past the pin. Slowly release the latch knob.

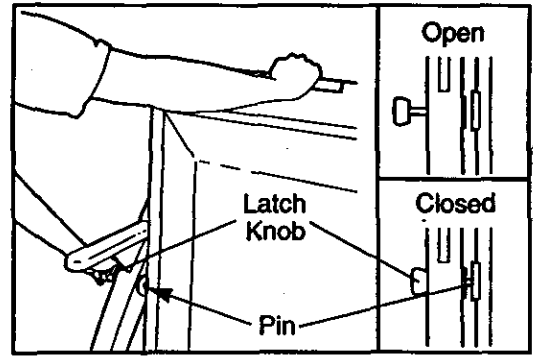

2. Hold the treadmill firmly with both hands, and lower the treadmill to the floor. **CAUTION: To decrease the possibility of injury, bend your legs and keep your back straight.**

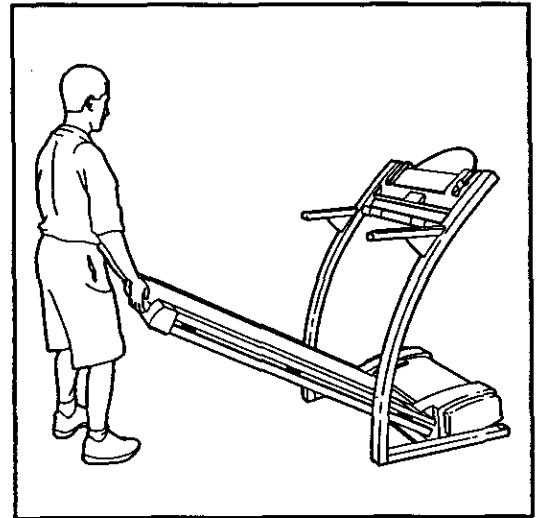



# MAINTENANCE AND TROUBLE-SHOOTING

Most treadmill problems can be solved by following the simple steps below. Find the symptom that applies, and follow the steps listed. If further assistance is needed, call our toll-free HELPLINE at 1-800-736-6879, Monday through Saturday, 7 a.m. until 7 p.m. Central Time (excluding holidays).

## 1. SYMPTOM: THE POWER DOES NOT TURN ON

- a. Make sure that the power cord is plugged into a surge suppressor, and that the surge suppressor is plugged into a properly grounded outlet (see page 7). Use only a single-outlet surge suppressor that is UL 1449 listed as a transient voltage surge suppressor (TVSS). The surge suppressor must have a UL suppressed voltage rating of 400 volts or less and a minimum surge dissipation of 450 joules. The surge suppressor must be electrically rated for 120 volts AC and 15 amps.
- b. After the power cord has been plugged in, make sure that the key is inserted into the console as far as it will go. See step 1 on page 9.
- c. Check the circuit breaker located on the treadmill near the power cord. If the switch protrudes as shown, the circuit breaker has tripped. To reset the circuit breaker, wait for five minutes and then press the switch back in.
- d. Check the on/off switch located on the treadmill near the power cord. The switch must be in the on position.

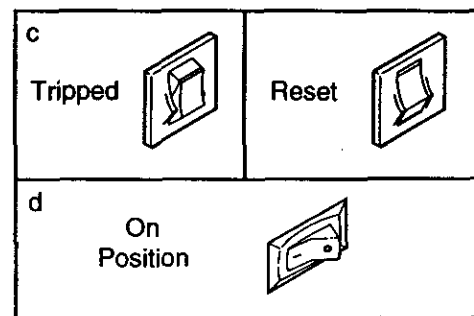

## 2. SYMPTOM: THE POWER TURNS OFF DURING USE

- a. Check the circuit breaker located on the treadmill frame near the power cord (see 1. c. above). If the circuit breaker has tripped, wait for five minutes and then press the switch back in.
- b. Make sure that the power cord is plugged in.
- c. Remove the key from the console. Reinsert the key fully into the console. See step 1 on page 9.
- d. Make sure that the on/off switch is in the on position.
- e. If the treadmill still will not run, please call our toll-free HELPLINE.

## 3. SYMPTOM: THE PULSE SENSOR DOES NOT FUNCTION PROPERLY

- a. **Make sure to stand on the foot rails and avoid moving your hands while measuring your heart rate.** Excessive movement may interfere with heart rate readings. If the pulse sensor is not used correctly, your heart rate will not be shown.
- b. Do not hold the metal contacts too tightly; doing so may interfere with heart rate readings.
- c. For the most accurate heart rate reading, hold the contacts for about 15 seconds.
- d. For optimal performance of the pulse sensor, keep the contacts clean. The contacts can be cleaned with a soft cloth—never use alcohol, abrasives, or chemicals.

#### 4. SYMPTOM: THE DISPLAYS OF THE CONSOLE DO NOT FUNCTION PROPERLY

- a. Remove the six screws from the hood. Carefully remove the hood. Locate the Reed Switch (26) and the Magnet (107) on the left side of the Pulley (12). Turn the Pulley until the Magnet is aligned with the Reed Switch. **Make sure that the gap between the Magnet and the Reed Switch is about 1/8".** If necessary, loosen the Reed Switch Screw (109) and move the Reed Switch slightly. Retighten the Screw. Re-attach the hood, and run the treadmill for a few minutes to check for a correct speed reading.

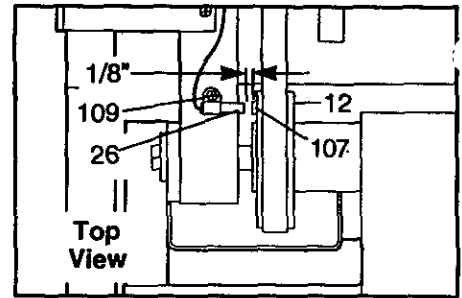

#### 5. SYMPTOM: The walking belt slows when walked on

- a. Use only a UL-listed surge protector, rated at 15 amps, with a 14-gauge cord of five feet or less in length.

- b. If the walking belt is overtightened, treadmill performance may decrease and the walking belt may be permanently damaged. Remove the key and **UNPLUG THE POWER CORD**. Using the allen wrench, turn both rear roller adjustment bolts counterclockwise, 1/4 of a turn. When the walking belt is properly tightened, you should be able to lift each side of the walking belt 3 to 4 inches off the walking platform. Be careful to keep the walking belt centered. Plug in the power cord, insert the key and run the treadmill for a few minutes. Repeat until the walking belt is properly tightened.

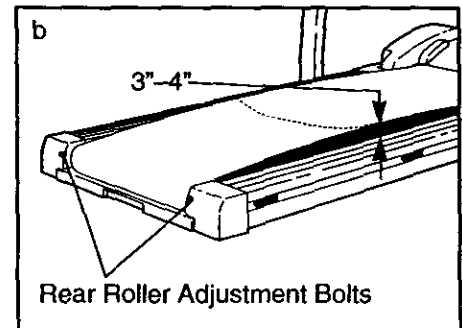

- c. If the walking belt still slows when walked on, please call our toll-free HELPLINE.

#### 6. SYMPTOM: The walking belt is off-center

- a. If the walking belt has shifted to the left, first remove the key and **UNPLUG THE POWER CORD**. Using the allen wrench, turn the left rear roller adjustment bolt clockwise, and the right bolt counterclockwise, 1/4 of a turn each. Be careful not to overtighten the walking belt. Plug in the power cord, insert the key and run the treadmill for a few minutes. Repeat until the walking belt is centered.

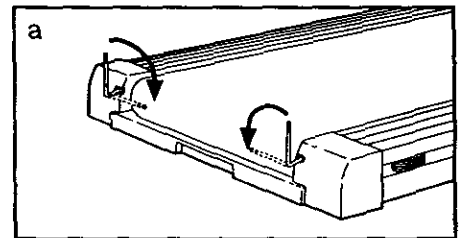

- b. If the walking belt has shifted to the right, first remove the key and **UNPLUG THE POWER CORD**. Using the allen wrench, turn the left rear roller adjustment bolt counterclockwise, and the right bolt clockwise, 1/4 of a turn each. Be careful not to overtighten the walking belt. Plug in the power cord, insert the key and run the treadmill for a few minutes. Repeat until the walking belt is centered.

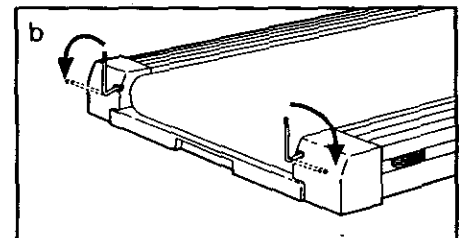

#### 7. SYMPTOM: The walking belt slips when walked on

- a. If the walking belt slips when walked on, first remove the key and **UNPLUG THE POWER CORD**. Using the allen wrench, turn both rear roller adjustment bolts clockwise, 1/4 of a turn. When the walking belt is correctly tightened, you should be able to lift each side of the walking belt 3 to 4 inches off the walking platform. Be careful to keep the walking belt centered. Plug in the power cord, insert the key and carefully walk on the treadmill for a few minutes. Repeat until the walking belt is properly tightened.

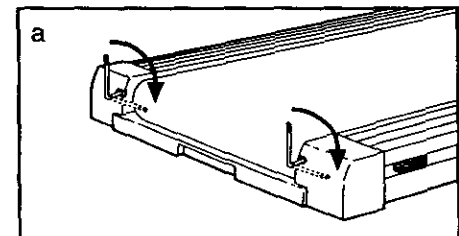

# CONDITIONING GUIDELINES

**⚠ WARNING:** Before beginning this or any exercise program, consult your physician. This is especially important for individuals over the age of 35 or individuals with pre-existing health problems.

The pulse sensor is not a medical device. Various factors, including your movement, may affect the accuracy of heart rate readings. The sensor is intended only as an exercise aid in determining heart rate trends in general.

The following guidelines will help you to plan your exercise program. Remember—these are general guidelines only. For more detailed exercise information, obtain a reputable book or consult your physician.

## EXERCISE INTENSITY

Whether your goal is to burn fat or to strengthen your cardiovascular system, the key to achieving the desired results is to exercise with the proper intensity. The proper intensity level can be found by using your heart rate as a guide. The chart below shows recommended heart rates for fat burning and aerobic exercise.

HEART RATE TRAINING ZONES							
AEROBIC	165	155	145	140	130	125	115
MAX FAT BURN	145	138	130	125	118	110	103
FAT BURN	125	120	115	110	105	95	90
Age	20	30	40	50	60	70	80

To find the proper heart rate for you, first find your age near the bottom of the chart (ages are rounded off to the nearest ten years). Next, find the three numbers above your age. The three numbers define your "training zone." The lower two numbers are recommended heart rates for fat burning; the higher number is the recommended heart rate for aerobic exercise.

To measure your heart rate during exercise, use the pulse sensor on the console. If your heart rate is too high or too low, adjust the speed and incline of the treadmill.

## Fat Burning

To burn fat effectively, you must exercise at a relatively low intensity level for a sustained period of time. During the first few minutes of exercise, your body

uses easily accessible *carbohydrate calories* for energy. Only after the first few minutes does your body begin to use stored *fat calories* for energy. If your goal is to burn fat, adjust the speed and incline of the treadmill until your heart rate is near the lowest number in your training zone. It may also be helpful to use one of the console's FAT BURN programs (see pages 10 and 11).

For maximum fat burning, adjust the speed and incline of the treadmill until your heart rate is near the middle number in your training zone.

## Aerobic Exercise

If your goal is to strengthen your cardiovascular system, your exercise must be "aerobic." Aerobic exercise is activity that requires large amounts of oxygen for prolonged periods of time. This increases the demand on the heart to pump blood to the muscles, and on the lungs to oxygenate the blood. For aerobic exercise, adjust the speed and incline of the treadmill until your heart rate is near the highest number in your training zone. It may also be helpful to use one of the console's AEROBIC programs (see pages 10 and 11).

## WORKOUT GUIDELINES

Each workout should include the following three parts:

**A Warm-up**—Start each workout with 5 to 10 minutes of stretching and light exercise. A proper warm-up increases your body temperature, heart rate and circulation in preparation for exercise.

**Training Zone Exercise**—After warming up, increase the intensity of your exercise until your pulse is in your training zone for 20 to 60 minutes. (During the first few weeks of your exercise program, do not keep your pulse in your training zone for longer than 20 minutes.) Breathe regularly and deeply as you exercise—never hold your breath.

**A Cool-down**—Finish each workout with 5 to 10 minutes of stretching to cool down. This will increase the flexibility of your muscles and will help prevent post-exercise problems.

## Exercise Frequency

To maintain or improve your condition, complete three workouts each week, with at least one day of rest between workouts. After a few months, you may complete up to five workouts each week if desired. The key to success is to make exercise a regular and enjoyable part of your everyday life.

## SUGGESTED STRETCHES

The correct form for several basic stretches is shown at the right. Move slowly as you stretch—never bounce.

### 1. Toe Touch Stretch

Stand with your knees bent slightly and slowly bend forward from your hips. Allow your back and shoulders to relax as you reach down toward your toes as far as possible. Hold for 15 counts, then relax. Repeat 3 times. Stretches: Hamstrings, back of knees and back.

### 2. Hamstring Stretch

Sit with one leg extended. Bring the sole of the opposite foot toward you and rest it against the inner thigh of your extended leg. Reach toward your toes as far as possible. Hold for 15 counts, then relax. Repeat 3 times for each leg. Stretches: Hamstrings, lower back and groin.

### 3. Calf/Achilles Stretch

With one leg in front of the other, reach forward and place your hands against a wall. Keep your back leg straight and your back foot flat on the floor. Bend your front leg, lean forward and move your hips toward the wall. Hold for 15 counts, then relax. Repeat 3 times for each leg. To cause further stretching of the achilles tendons, bend your back leg as well. Stretches: Calves, achilles tendons and ankles.

### 4. Quadriceps Stretch

With one hand against a wall for balance, reach back and grasp one foot with your other hand. Bring your heel as close to your buttocks as possible. Hold for 15 counts, then relax. Repeat 3 times for each leg. Stretches: Quadriceps and hip muscles.

### 5. Inner Thigh Stretch

Sit with the soles of your feet together and your knees outward. Pull your feet toward your groin area as far as possible. Hold for 15 counts, then relax. Repeat 3 times. Stretches: Quadriceps and hip muscles.

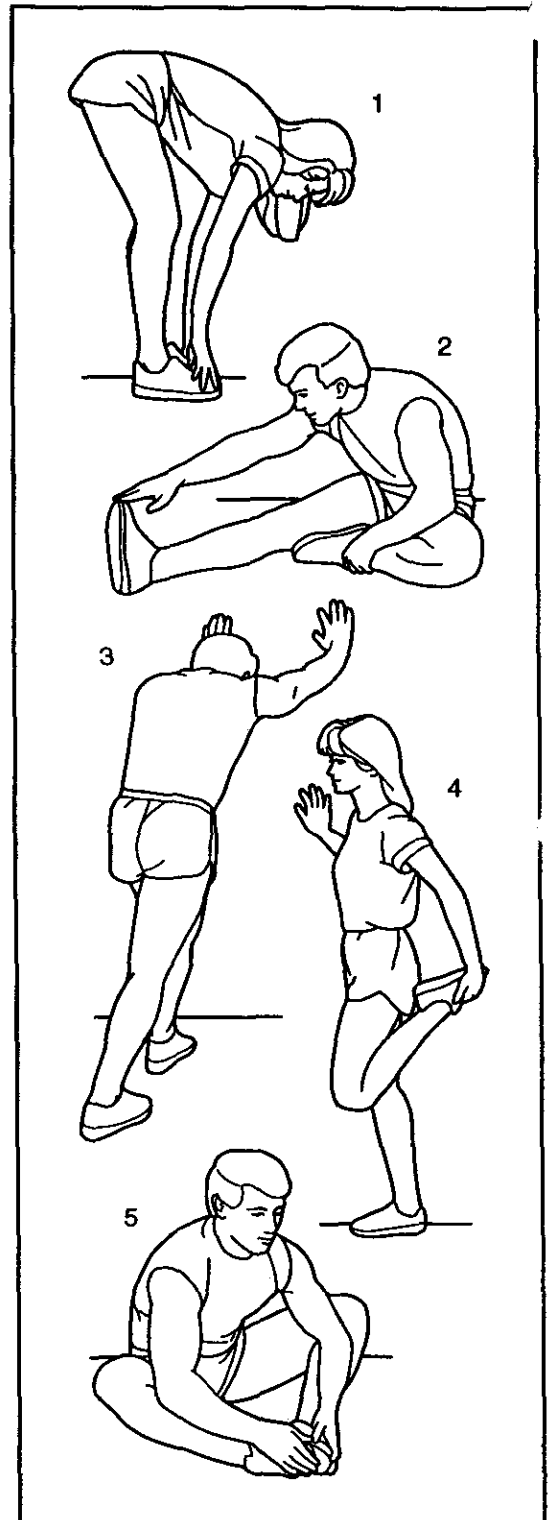

**NOTES**

---

# PART LIST—Model No. 831.297990

R1198A

To identify parts listed below, refer to the EXPLODED DRAWING attached in the center of this manual.

Key No.	Qty.	Description	Key No.	Qty.	Description
1	2	Center Track	51	1	Power Supply
2	2	Foot Rail	52	4	Plastic Stand-off
3	1	Left Foot Rail Cap	53	1	Power Cord
4	1	Front Roller Adjustment Nut	54	1	Grommet
5	4	Isolator	55	1	On/Off Switch
6	6	Bumper	56	1	Circuit Breaker
7	6	Platform Screw	57	1	Outlet Bracket
8	1	Walking Platform	58	1	Book Rack
9	2	Frame Pivot Bolt	59	2	Belt Guide
10	2	Frame Pivot Spacer	60	1	Shock
11	1	Walking Belt	61	1	Front Belly Pan
12	1	Front Roller/Pulley	62	1	Right Foot Rail Cap
13	28	Small Screw	63	26	Belly Pan Fastener
14	1	Motor Belt	64	1	Console Base
15	1	Base	65	2	Frame Guide Screw
16	1	Incline Frame	66	1	Frame Guide
17	2	Hood Bracket (long)	67	2	Rear Isolator
18	3	Bracket Clip	68	1	Belly Pan
19	4	Small Screw	69	1	Warning Decal
20	1	Console Plate	70	4	Hood Screw
21	8	Nut	71	1	Key/Clip
22	1	Lift Motor Shield	72	2	Rear Endcap Bracket
23	2	Incline Motor Bolt	73	1	Rear Endcap
24	1	Allen Wrench	74	2	Rear Endcap Pad
25	1	Incline Motor	75	7	Endcap Screw/Ground Screw
26	1	Reed Switch	76	2	Rear Roller Adj. Bolt
27	1	Upright Plug	77	2	Caution Decal
28	1	Upright Ground Screw	78	1	Latch Decal
29	1	Adhesive Clip	79	1	Frame
30	2	Wheel Bolt	80	2	Rear Deck Screw
31	2	Front Wheel	81	1	Console
32	1	Hood Bracket (short)	82	1	Latch Catch
33	1	Motor Pivot Nut	83	1	Rear Roller
34	1	Pulley/Flywheel/Fan	84**	1	Optional Chest Pulse
35	1	Motor	85	1	Cable Tie
36	3	Motor Tension Bolt	86	2	Cable Tie Screw
37	1	Motor Tension Washer	87	2	Cable Tie Clamp
38	1	Star Washer	88	2	8" Cable Tie
39	1	Motor Tension Nut	89	5	4" Cable Tie
40	1	Motor Pivot Bolt	90	1	Upright Wire Harness
41	1	Motor Hood	91	2	Handrail Grip
42	1	Incline Motor Shield	92	1	Lock Knob
43	2	Incline Pivot Washer	93	1	Lock Knob Sleeve
44	3	Adj. Washer	94	1	Spring
45*	1	Motor/Pulley/Fly./Fan	95	1	Lock Pin Collar
46	1	Front Roller Adj. Bolt	96	1	Pin Clip
47	1	Choke	97	1	Lock Pin
48	1	Electronics Bracket	98	1	8" Wire Harness
49	1	Controller	99	4	Pulse Sensor Plate
50	1	Electronics Shield	100	1	Ground Wire

<b>Key No.</b>	<b>Qty.</b>	<b>Description</b>
101*	1	Pulse Bar
102	32	Screw
103	2	Pulse Bar Washer
104	2	Pulse Bar Bolt
105	4	Upright Endcap
106	1	Upright Grommet
107	1	Magnet
108	1	Incline Reed Switch
109	1	Reed Switch Screw
110	1	Reed Switch Clip
111	2	Endcap Spacer
112	2	2-lb Weight
113	2	3-lb Weight
114	2	Cushion Plate
115	2	Adjustable Deck Cushion
116	2	Rod Nut
117	2	Rod Bolt
118	1	Cushion Rod
119	1	Incline Motor Spacer
120	1	Incline Optic Disk

<b>Key No.</b>	<b>Qty.</b>	<b>Description</b>
121	1	Optic Switch Nut
122	1	Optic Switch Washer
123	1	Optic Switch Bolt
124	1	Optic Switch
#	1	14" White Wire, 2 F
#	1	8" White Wire, M/F
#	1	4" White Wire, M/F
#	1	4" Black Wire, 2 F
#	1	4" Black Wire, M/Ring
#	1	9" Black Wire, M/F
#	1	8" Blue Wire, 2 F
#	1	8" Red Wire, M/F
#	1	8" Green Wire, F/Ring
#	1	User's Manual

# These parts are not illustrated  
 \* Includes all parts shown in the box

\*\* For more information about the optional pulse kit, see page 14.

Specifications are subject to change without notice. For information about ordering replacement parts, see the back cover of this manual.

**EXPLODED DRAWING—Model No. 831.297990**

R1198A

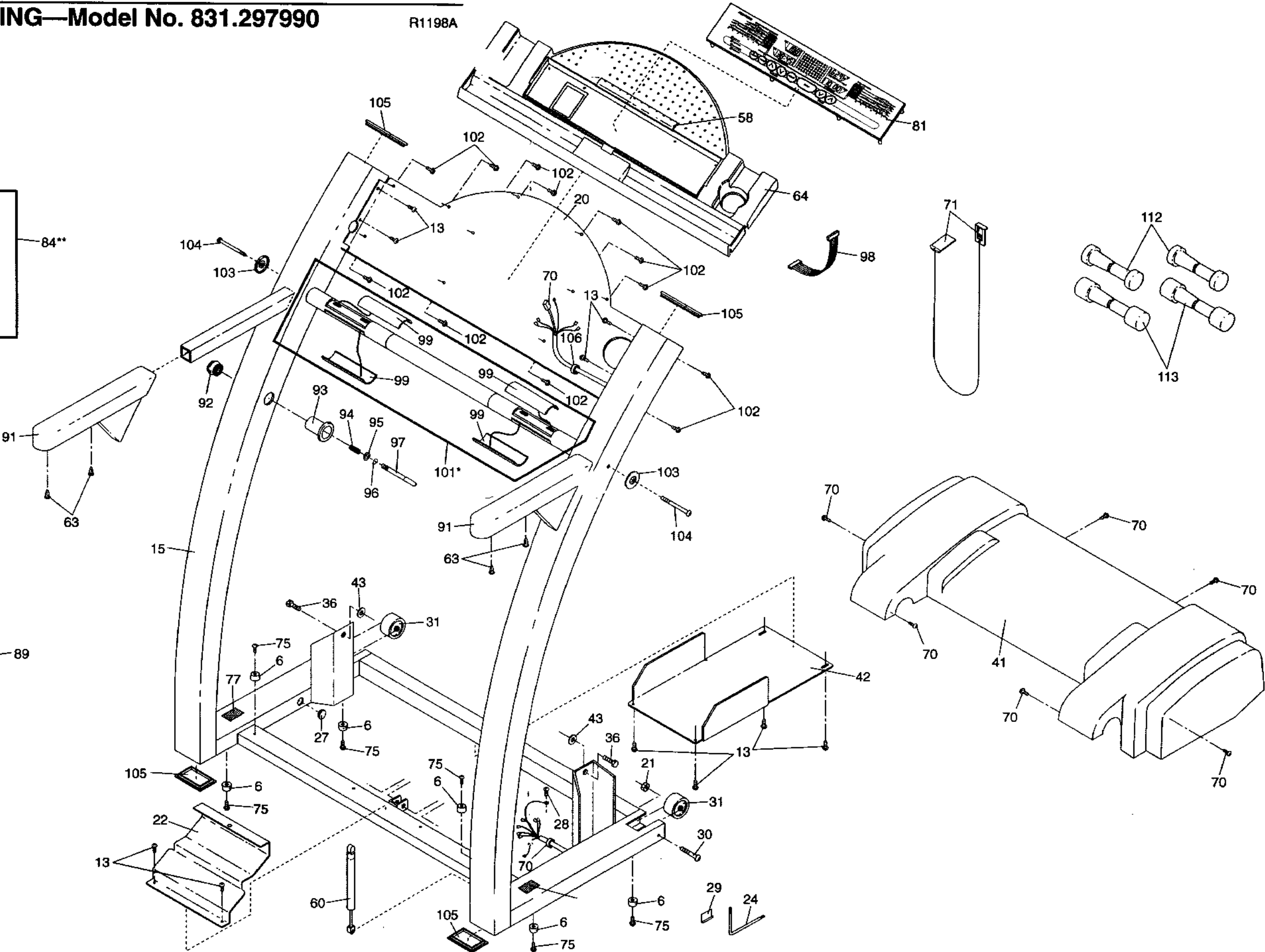
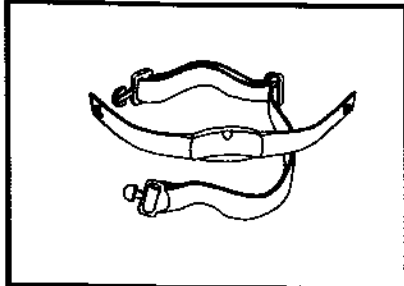



**EXPLODED DRAWING—Model No. 831.297990**

R1198A

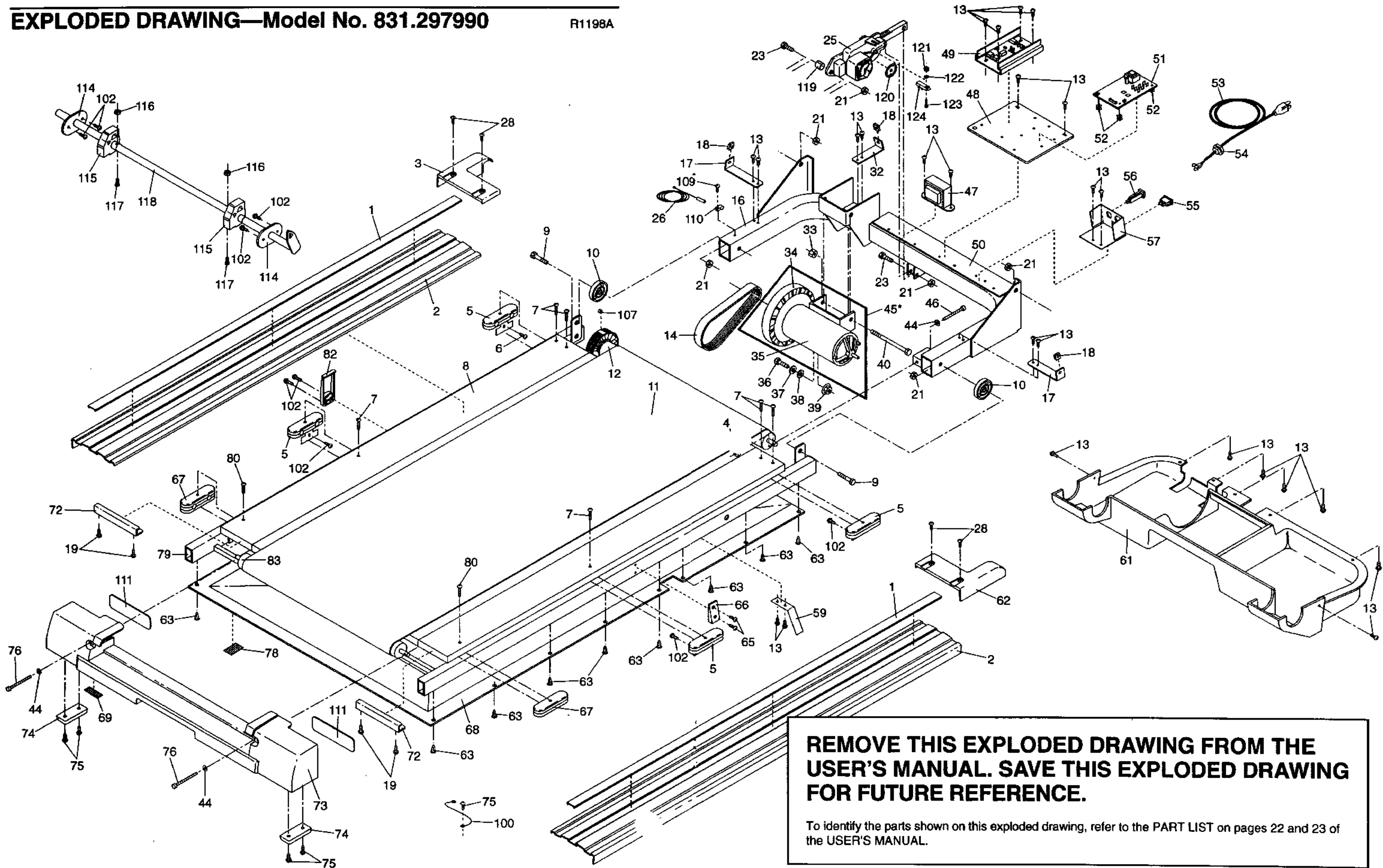

**REMOVE THIS EXPLODED DRAWING FROM THE USER'S MANUAL. SAVE THIS EXPLODED DRAWING FOR FUTURE REFERENCE.**

To identify the parts shown on this exploded drawing, refer to the PART LIST on pages 22 and 23 of the USER'S MANUAL.

# SEARS

**Model No. 831.297990**

## QUESTIONS?

If you find that:

- you need help assembling or operating the PROFORM J8li treadmill
- a part is missing
- or you need to schedule repair service

call our toll-free HELPLINE

**1-800-736-6879**

Monday-Saturday, 7 am-7 pm  
Central Time (excluding holidays)

## REPLACEMENT PARTS

If parts become worn and need to be replaced, call the following toll-free number

**1-800-FON-PART  
(1-800-366-7278)**

The model number and serial number of your PROFORM® J8li treadmill are listed on a decal attached to the frame. See the front cover of this manual to find the location of the decal.

All replacement parts are available for immediate purchase or special order when you visit your nearest SEARS Service Center. To request service or to order parts by telephone, call the toll-free numbers listed at the left.

When requesting help or service, or ordering parts, please be prepared to provide the following information:

- The NAME OF THE PRODUCT (PROFORM® J8li treadmill)
- The MODEL NUMBER OF THE PRODUCT (831.297990)
- The KEY NUMBER AND DESCRIPTION OF THE PART (see the EXPLODED DRAWING and PART LIST included in this manual)

## FULL 90 DAY WARRANTY

For 90 days from the date of purchase, if failure occurs due to defect in material or workmanship in this SEARS TREADMILL EXERCISER, contact the nearest SEARS Service Center throughout the United States and SEARS will repair or replace the TREADMILL EXERCISER, free of charge.

This warranty does not apply when the TREADMILL EXERCISER is used commercially or for rental purposes.

This warranty gives you specific legal rights, and you may also have other rights which vary from state to state.

**SEARS, ROEBUCK AND CO., DEPT. 817WA, HOFFMAN ESTATES, IL 60179**

## Free Manuals Download Website

<http://myh66.com>

<http://usermanuals.us>

<http://www.somanuals.com>

<http://www.4manuals.cc>

<http://www.manual-lib.com>

<http://www.404manual.com>

<http://www.luxmanual.com>

<http://aubethermostatmanual.com>

Golf course search by state

<http://golfingnear.com>

Email search by domain

<http://emailbydomain.com>

Auto manuals search

<http://auto.somanuals.com>

TV manuals search

<http://tv.somanuals.com>