

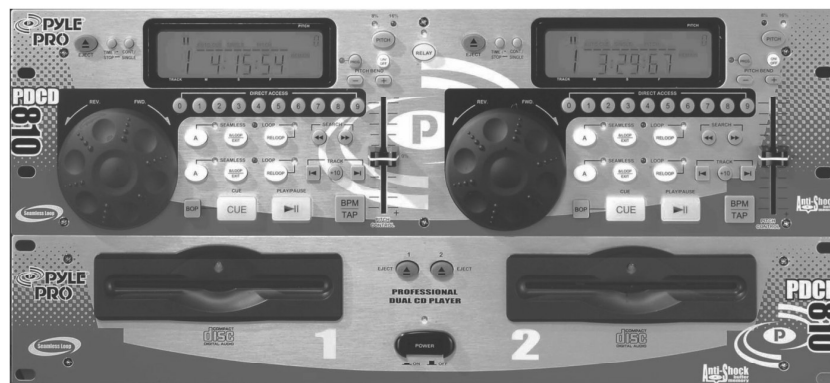

# PDCD810

**PROFESSIONAL DUAL CD PLAYER  
WITH SEAMLESS LOOP**



---

**INSTRUCTION MANUAL**

---

# TABLE OF CONTENTS

<b>NOTE ON USE .....</b>	<b>2</b>
<b>FOR SAFE AND EFFICIENT OPERATION .....</b>	<b>2</b>
<b>DESCRIPTION OF THE FUNCTIONS .....</b>	<b>3</b>
FUNCTION OF THE MAIN UNIT.....	3
FUNCTION OF THE CONTROL UNIT.....	4
CONNECTIONS .....	6
<b>BASIC OPERATION .....</b>	<b>7</b>
LOADING AND EJECTING THE DISC .....	7
TRACK SKIP .....	8
ANTI SHOCK MEMORY.....	8
MATCHING THE BEATS PER MINUTE .....	9
BEAT MATCHING USING PITCH BEND.....	9
<b>OPERATION OF CUE AND LOOP .....</b>	<b>10</b>
<b>BEFORE SWITCHING OFF THE POWER .....</b>	<b>11</b>
<b>TROUBLESHOOTING GUIDE .....</b>	<b>11</b>

## NOTE ON USE

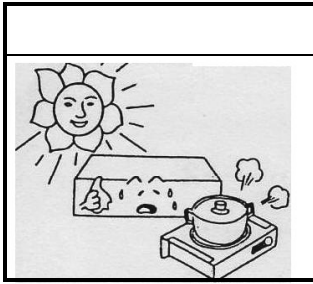

BE CAREFUL OF HIGH TEMPERATURE

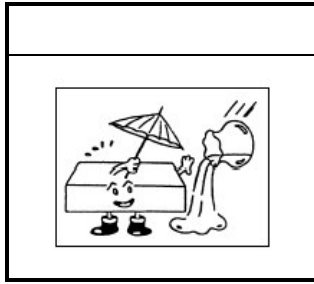

TO AVOID DUST & MOISTURE

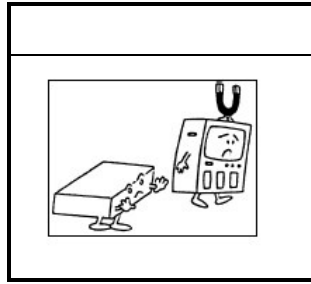

TO AVOID PLACING ON UNSTABLE LOCATION

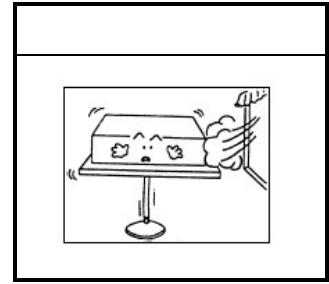

DO NOT USE CHEMICALS

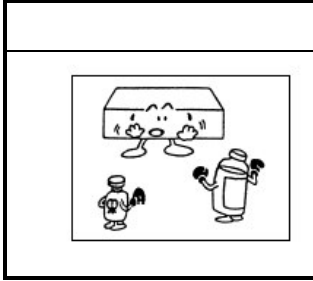

IF OUT OF WORK, CONTACT SALES AGENCY IMMEDIATELY

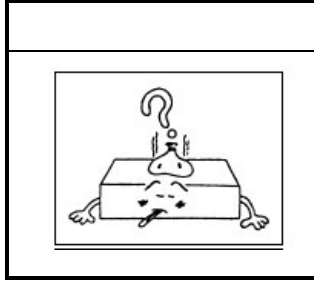

KEEP AWAY FROM TV & MAGNETISM

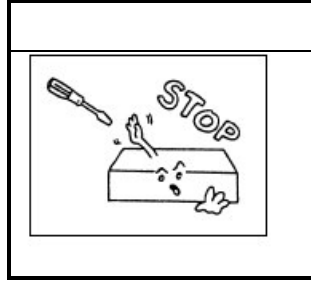

DO NOT OPEN THE CASE

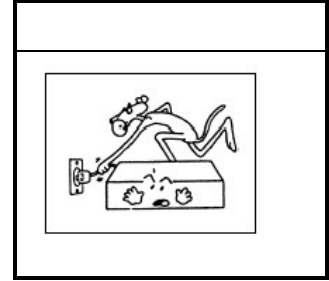

CARE WITH THE POWER CORD

### For Safe and Efficient Operation

- Select the installation location of your unit carefully. Avoid placing it in direct sunlight. Also avoid locations subject to vibration and excessive dust, heat, cold or moisture. Keep away from sources of hum such as transformers or motors.
- Do not use this compact disc player where there are extremes in temperature ( below 41 ° F/5 ° C or exceeding 95 ° F/35 ° C ).
- Do not open the cabinet as this might result in damage to the set or electrical shock.
- Be sure your hands are clean when handing discs. Never insert a disc which has a crack on its surface.
- When disconnecting the power cord from the AC outlet, always grasp it by the plug. Never pull the cord.
- Do not use force when operating the switches and buttons.
- Before moving the set, be sure to disconnect the power cord and all connecting cables.
- To keep the laser pickup clean, do not forget to close the disc tray.
- Do not attempt to clean the unit with chemical solvents as this might damage the finish. Use a clean, dry cloth.
- Keep this manual in a safe place for future reference.

### SAFETY CERTIFICATION

Laser Diode Properties  
 Material: Ga.-Al-As  
 Wavelength: 755-815 nm (25°C)  
 Laser Output: Continuous Wave max. 0.5mW

#### CAUTION:

*USE OF CONTROLS OR ADJUSTMENTS OR PERFORMANCE OF PROCEDURES OTHER THAN THOSE SPECIFIED HEREIN MAY RESULT IN HAZARDOUS RADIATION EXPOSURE.*

CAUTION

To prevent electric shock do not remove cover (or bottom screws). No user serviceable parts inside refer servicing to qualified servicing personnel.

# DESCRIPTION OF THE FUNCTIONS

## Function of the Main Unit :

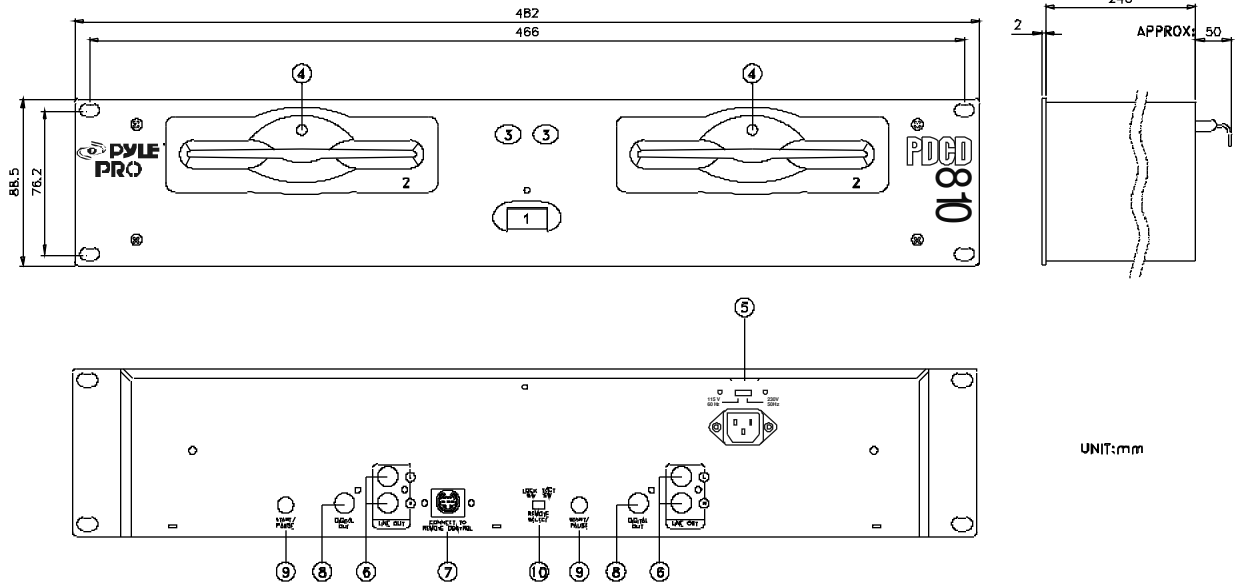

### 1. POWER (Power Switch)

Press the power switch to turn the unit on. To switch the POWER off press the POWER switch again.

### 2. Disc Loader

The disc is placed on the loader and the CD disc will be loaded automatically. Pressing the Eject button to eject the CD Disc tray.

### 3. Eject Button

Press to load or eject the disc

### 4. DISC illuminator

To illuminate for disc.

### 5. AC INPUT

Connecting this power cord into an AC wall outlet with the proper AC voltage.

### 6. LINE OUT (Output Jacks)

The audio from each CD player is output from these jacks. Connect to the line input of the mixer.

### 7. CONNECTOR PORTS

The 8-pin termination permits the connection of the main unit to the control unit.

### 8. DIGITAL OUT

The digital from each CD player is output from these jacks. Connect to the line input of the D/A Amplifier.

### 9. START/PAUSE

This connector is used for fader start; connect it to a mixer and remote control the "START/PAUSE" by moving the fader of mixer.

### 10. TACT-LOCK option

Select the type of switch in the mixer for FADERSTART wire remote control.

# Function of the Control Unit

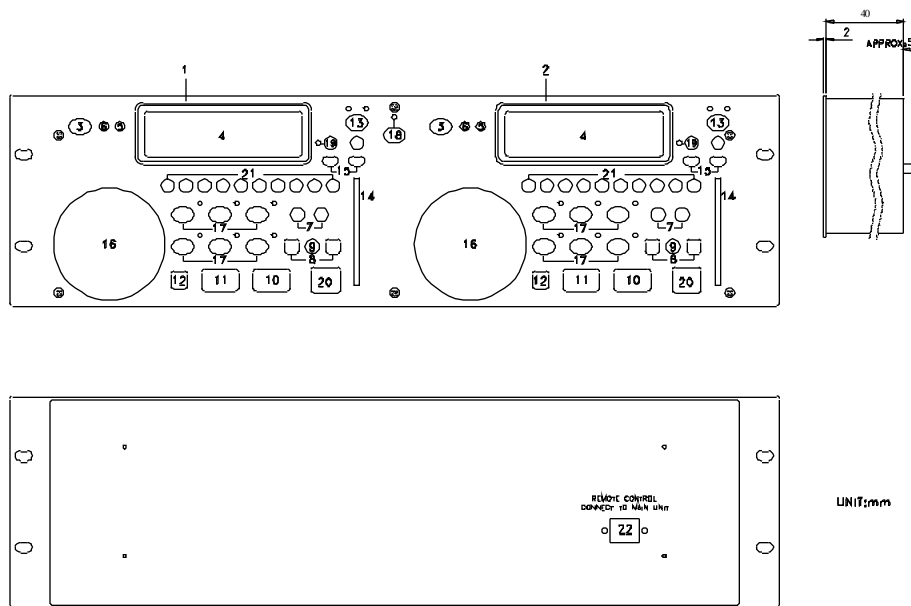

## 1. UNIT 1-CONTROL OPERATION PANEL

This operation panel remotely controls the main unit 1.

## 2. UNIT 2- CONTROL OPERATION PANEL

This operation panel remotely controls the main unit 2.

## 3. OPEN/ CLOSE BUTTON

Press to load or eject the disc. Each press will open or close the disc tray.

**Note:** Disc will not eject. Unless the stop or pause button has been push first

## 4. L.C.D

These liquid crystal display (L.C.D.) indicate the track numbers, time (minutes, second, frame), remain, pitch, beat, loop, auto cue single, continue and time bar.

## 5. CONT./SINGLE BUTTON ( OUTRO)

To press this button it can switch between auto cue single and continue. The selected mode is indicated on the display.

\*AUTO CUE SINGLE-After each track, the unit pauses at the beginning of next track. The playback starts from audible point.

\*CONTINUE—To play the whole tracks.

\*OUTRO-Press the button for 3 seconds for OUTRO function, the unit will play the last 30 seconds of each track.

## 6.TIME / STOP BUTTON

This button switches the time display between each remaining time, elapsed playing time, and total remaining time. The unit will be in the "stop" mode if you continue to press the button for more than 3 seconds.

## 7.SEARCH BUTTON

Pressing the button for quick forward or backward

## 8.TRACK BUTTON

This button selects the track to be played

## 9.+10 BUTTON

Pressed the button to forward 10 tracks. If you forward 10 tracks, and the tracks over total tracks, the unit will jump to track 1.

## 10. PLAY/ PAUSE BUTTON

Each press of this button causes the operation to change between PLAY and PAUSE modes.

## 11. CUE BUTTON

The cue function allows the CD to be played from the memorized point any number of times. With the unit in the pause mode, pressing the CUE button to set up the memorized cue point and then the cue button blinks.

## 12. BOP BUTTON

The playback will automatically play from the CUE point upon the button is pressed.

## 13. PITCH BUTTON

With unit on the PITCH ON mode, to select the pitch range from 8%, 16%, which the LED indicator flashes. To select 8 % will assign +/-8 % to pitch control slider and so does 16%. With the unit on the PITCH OFF mode, it means playback speed is normal (0%). The playback speed will not change when you move the pitch control slider.

## 14. PITCH CONTROL SLIDER

To match the choices of playback speed (8%, 16%), you can choose what range you want between minimum (up side) and maximum (bottom side) by moving the pitch control slider.

## 15. PITCH BEND + / - BUTTON

When each of the two CD players is playing, the pitch bend function allows the position of the bass beat to be matched after the pitch has been adjusted. The pitch will automatically rise up to + 16% from the current setting while pressing the " + "button. While pressing the " - " button, the pitch will automatically drop to - 16 % from current setting. By the way of changing the pitch the position of the beats can be matched.

## 16. JOG WHEEL

This contains various functions, as follows:

### \*Speed Control

Rotating the wheel, in play mode, will change the playback speed accordingly. While rotating clockwise, the player speed increase; rotating counterclockwise, the speed decrease.

### \*Searching

Rotating the wheel in pause mode, the player will forward or backward to the desired point to start. The searching speed changed according to the dialing speed. It can be carried out by one frame increment.

## 17. Seamless Loop (2 set)

There is A, B/LOOP/ EXIT, RELOOP buttons.

1. A BUTTON---"start point" (A point. Also, Cue 1 could be a A point) After setting up the A point, the red Led light up!
2. B/LOOP/ EXIT BUTTON: ---" End point"(B point). Press the B /LOOP button to set up the B point and start the loop playback automatically. Loop lights on the display and the 3 LEDs flash. Press this button again to exit the LOOP playback.
3. RELOOP BUTTON  
Return to the loop playback by pressing the RELOOP while in performance. However, if your want to return to loop playback, you can press RELOOP BUTTON.
4. Change " START POINT" and" END POINT" by pressing the A& B/ LOOP/ EXIT button again.

The interval between A and B point must be more than 20 frames; otherwise, the B point will be canceled, then LOOP function disappear and LOOP fades on the display.

## 18. RELAY

Press the "RELAY" button to activate. When one unit is in play mode, and the other unit is in "pause" mode; pause the playing unit, the other unit will automatically start to play.

## 19. PROGRAM BUTTON

You can program the track you want. While the unit is stopped, pressing the PROG button first to enter memorized mode, by pressing the skip buttons to select the tracks you want to order and then press the PROG button again to complete set up per track. The max tracks you can program are 30 tracks. While playing programmed tracks, the LED of PROG lights up. While the unit is stopped, open the tray disc or turn off the power, the program will be exited.

## 20. BPM BUTTON

To get the BPM number manually.

## 21. Direct Access Key(0~9)

To select the number of the track you would like to play.

## 22. CONNECTOR PORTS

The 8-pin termination permits the connection of the control unit to the main unit.

## 23. SLEEP:

Leave the unit unused for 30 minutes; the machine will shut off automatically.

## Connections

Typical connections with a mixer is illustrated below. Please use it for reference.

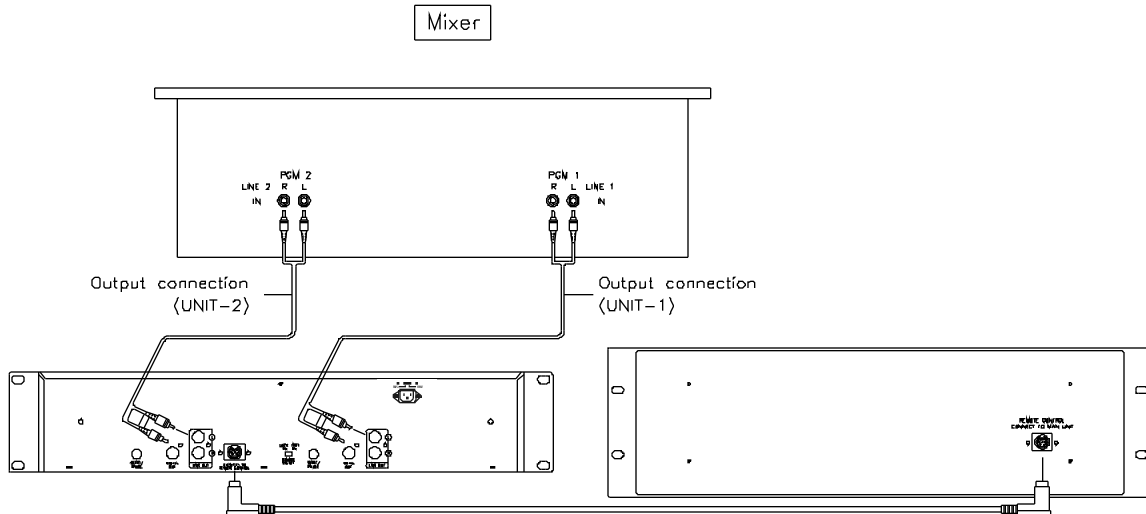

- \* Connect the connection cords to the line inputs of your mixer.
- \* The connection cords and the remote control connection cable are supplied with the main unit.
- \* Be sure to use the remote control connection cable which has been supplied. Use of another cable type might cause damage.

# BASIC OPERATION

## Loading and Ejecting the Disc

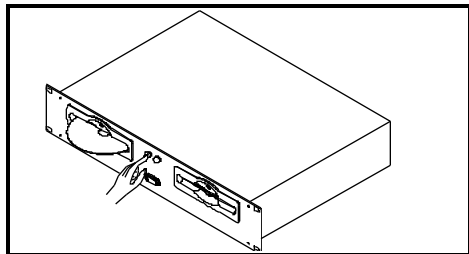

When the disc is loaded, press the EJECT button to eject the disc (This may be done on either the player or the remote control side.)

Place a disc in the disc loader

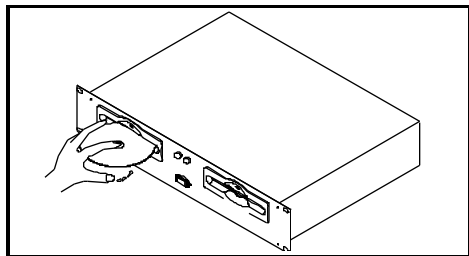
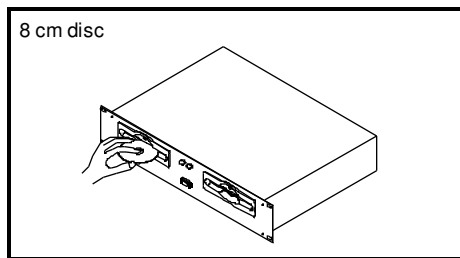
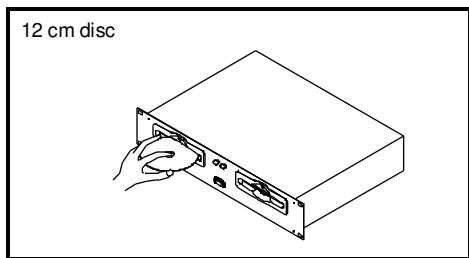

Push the disc to the loader.

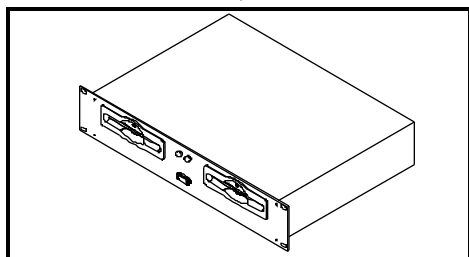

While the disc is loaded, the preparation for disc play will begin.

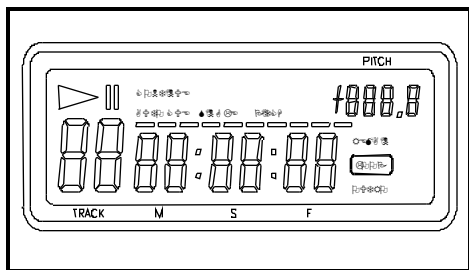

When preparation is completed, the total tracks number & total playing time will display.

To the desired track

# TRACK SKIP

To go back through the tracks

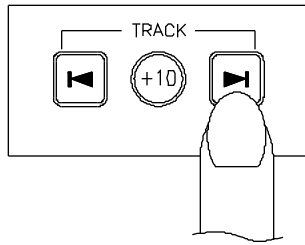

Tracks change as follows  
(This is for a disc containing 4 tracks)

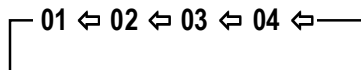

When this button is pressed once, the CD player will skip backward to the beginning of the track, press twice will skip backward to the previous track.

To advance through the tracks

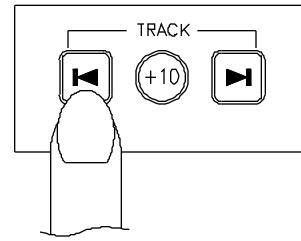

Tracks change as follows

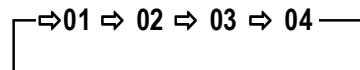

When this button is pressed once, the CD player will advance to the beginning of the next track.

## ANTI SHOCK MEMORY

This CD Player is equipped with an anti-shock memory, which memorizes 10 seconds of music before reading, to be not in case of shock.

**Warning:** This system can't work in case of repetitive shocks or vibrations and if the memory is not completely charged.



# MATCHING THE BEATS PER MINUTE

Match the pitch by monitoring the music of both UNIT 1 and UNIT 2 by ear. When the tempo of the music of the selected CD player is slow compared to the tempo of the other player, move the slider to the + side and match the tempo. When fast, move to the - side.

The following description is for the case of matching the pitch of UNIT 2 to the pitch of the music being played on UNIT 1.

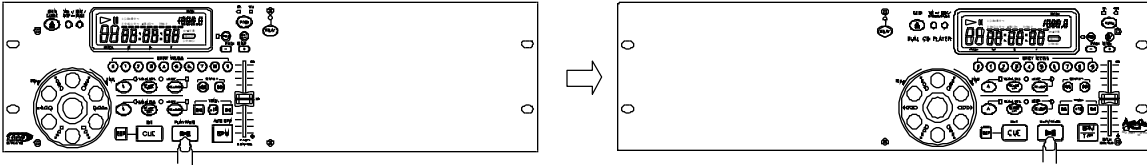

UNIT 1 is playing.

Press PLAY/PAUSE to start UNIT 2.

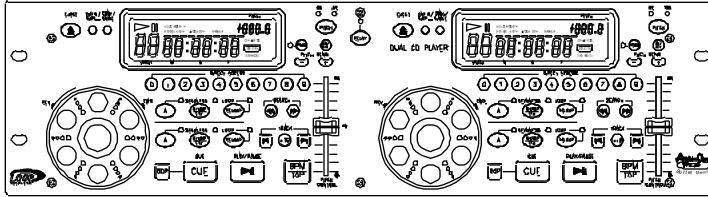

Both CD players are playing discs. Listen to UNIT 2 in your headphones.

When UNIT 2 is slow compared to UNIT 1

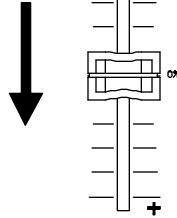

When UNIT 2 is fast compared to UNIT 1

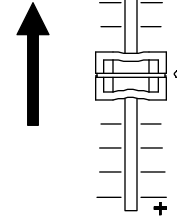

## Beat Matching Using Pitch Bend

A description of the procedure for matching the beat of UNIT 1 and UNIT 2 using the PITCH BEND stick is given below.

This description is for the case of matching the beat of UNIT 2 to the beat of the music being played on UNIT 1. (This procedure can be done on either Unit).

After Matching the BPM's

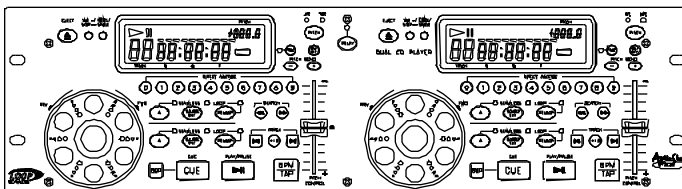

BPM's (Beat Per Minute) are the same, however the bass beats are not matched.

When UNIT 2 is ahead.

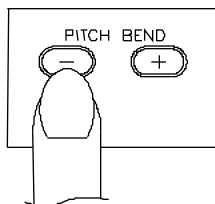

When UNIT 2 is behind.

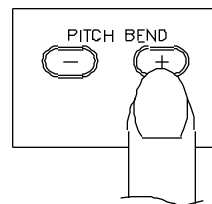

## OPERATION OF CUE (WITH PLAY/PAUSE)

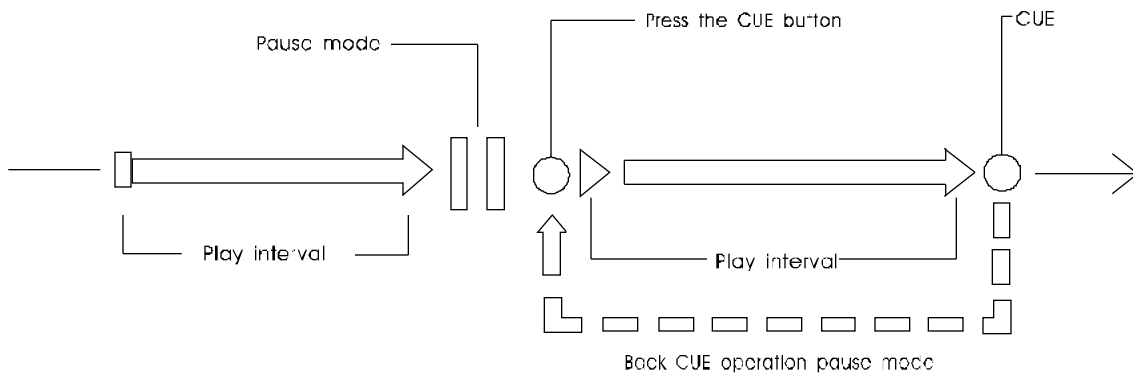

1. In pause mode, press CUE button to memorize a point for playing back. We mean it "cue point".
2. After "cue point" is memorized, in play mode, pressing CUE button will return the music back to the cue point and keep it in pause mode.
3. Press PLAY button again to perform from "cue point".

## OPERATION OF A AND B/LOOP

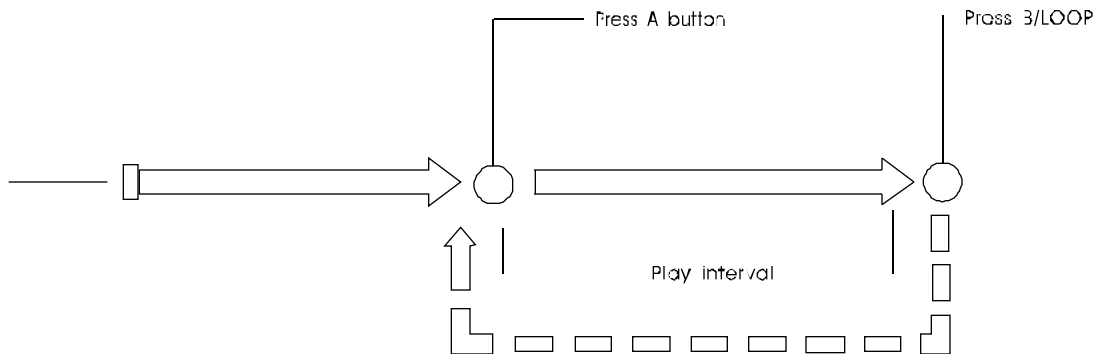

1. Set "A POINT" under play mode by pressing A button (without interruption during playback).
2. Press B/LOOP to memorize the ending point of loop, we mean it "B POINT". At the meantime, it blinks **LOOP** on the LCD, and the music automatically comes back to "A POINT" and loops between A & B points.
3. While the music loops between A & B, press **RELOOP/EXIT** to leave the loop. At the meantime, it lights **LOOP** on the LCD.
4. Press RELOOP again during playback, it returns the loop function.
5. Within play interval, you can change "A POINT" & "B POINT" by pressing A & B/LOOP button under play mode.
6. Also available to change "start point" by pressing A button in pause mode during loop function.
7. The interval between A & B point must be more than 20 frames, or the B point will be canceled, then loop function disappear, and **LOOP** fades on the LCD.

## BEFORE SWITCHING OFF THE POWER

When you have finished using the CD player, before switching off the power, ensure that the disc is ejected.

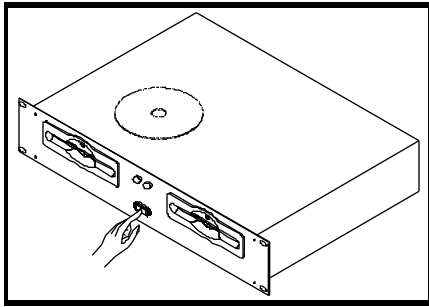

Do not switch off the power when the disc is in the loader.

**POWER OFF**

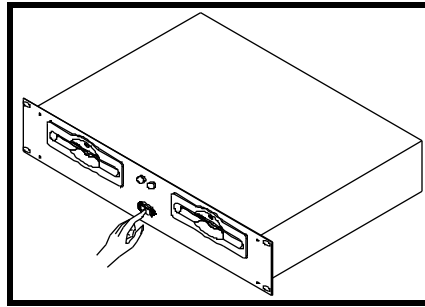

Switch off the power after the disc is ejected.

**POWER OFF**

## TROUBLESHOOTING GUIDE

If difficulties arise with your compact disc player, locate the apparent problem in the left-hand column of the table and follow the corrective action suggested in the right-hand column.

1. Is the compact disc player properly connected to the amplifier?
2. Is the amplifier set for the proper operation?
3. Have the operating instructions for the compact disc player been followed?

Symptom	Possible Cause	Corrective Action
The power fails to switch on when the POWER switch is set to ON	Poor power plug connection at the AC outlet.	Insert the power plug firmly into the AC outlet.
Disc play does not start	The disc is loaded upside down. The disc is too dirty.	Reload the disc with the label side up. Clean the disc.
No sound	Improper output cable connections. Improper amplifier operation.	Connect the output cable properly. Make sure that the amplifier controls are set properly.
Sound skips Hum	The CD player is subject to vibrations or physical shock. Loose cable connections.	Change the installation location. Firmly connect all audio plugs.

## Free Manuals Download Website

<http://myh66.com>

<http://usermanuals.us>

<http://www.somanuals.com>

<http://www.4manuals.cc>

<http://www.manual-lib.com>

<http://www.404manual.com>

<http://www.luxmanual.com>

<http://aubethermostatmanual.com>

Golf course search by state

<http://golfingnear.com>

Email search by domain

<http://emailbydomain.com>

Auto manuals search

<http://auto.somanuals.com>

TV manuals search

<http://tv.somanuals.com>