

Our obligation under this warranty is limited to the repair or replacement of the defective unit when it is returned to us prepaid. This warranty will be considered void if the unit was tampered with, improperly serviced, or subject to misuse, neglect, or accidental damage.

- You must also include the following items:
- A copy of your sales receipt or other proof of purchase
 - A brief letter indicating the problem you are experiencing
 - Include in your letter your return address, daytime phone number, and R.A. number
 - also include a check or money order for \$12.00 for return shipping, handling, and insurance, or provide your Visa/MC number with expiration date.

limited warranty policy amplifiers

PYLE

user's manual



high performance car audio amplifier



Optional protective endcaps included

- | | |
|---------|---------|
| PLA2170 | PLA4170 |
| PLA2270 | PLA4270 |
| PLA2370 | PLA4370 |
| PLA2470 | |
| PLA2570 | |

All Pyle products are carefully constructed and thoroughly tested before shipment. Products purchased in the USA are warranted to be free of defects in material and workmanship for two (2) years from the date of purchase. This warranty is limited to the original retail purchase.

Should the product fail due to factory defects in material or workmanship, your unit will be repaired or replaced at the sole discretion of Pyle.

To obtain warranty service you must first call our Consumer Return Hotline number at (718) 236-6948 to obtain a Return Authorization number. This R.A.# must appear on the outside of your package and on all paperwork relating to your return.

When returning a product to us for warranty service it must be carefully packed and shipped prepaid to:

PYLE

congratulations...



on your purchase of a Pyle Eternal Series amplifier. This amplifier extends the Pyle tradition into a totally new series of amps, designed from the ground up to deliver the power, performance and flexibility the modern car audio enthusiast demands.

When you check the list of features offered by the PLA2170, PLA2270, PLA2370, PLA2470, PLA2570, PLA4170, PLA4270, PLA4370, you'll know you made the right choice with a Pyle Eternal amplifier.

PYLE

table of contents



general features	2-5	high level input connections	21
features and specifications	6-11	PLA4170/ 4270/ 4370	
PLA2170/ 2270/ 2370		mono input connections	22
PLA2470/ 2570		PLA4170/ 4270/ 4370	
features and specifications	12-15	high level mono input connections	23
PLA4170/ 4270/ 4370		PLA4170/ 4270/ 4370	
electrical connections	16	speaker connections	24
PLA2170/ 2270/ 2370		PLA2170/ 2270/ 2370	
PLA2470/ 2570		PLA2470/ 2570	
PLA4170/ 4270/ 4370	17	speaker connections	25
stereo input connections	18	PLA4170/ 4270/ 4370	
PLA2170/ 2270/ 2370		speaker connections	26
PLA2470/ 2570		PLA4170/ 4270/ 4370	
mono input connections	19	mounting and installation	27
PLA2170/ 2270/ 2370		protection circuitry and troubleshooting	28
PLA2470/ 2570		precautions	29
2/4 channel input connections	20		
PLA4170/ 4270/ 4370			



PLA2170

High Performance 600 Watt 2 Channel Bridgeable MOSFET Amplifier

- 300 Watts x 2 Output
- 600 Watts x 1 Bridged Output
- Variable Hi/Lo Electronic Crossover Network
- Variable Bass Boost (0 - +18 dB @ 60Hz)
- Variable Input Level (Gain) Control
- Remote Turn On/Off
- Gold Plated RCA Inputs
- High Level MOLEX Input
- Power ON LED Indicator
- LED Protection Indicator
- S/N Ratio: > 95 dB
- THD: <0.04%
- Thermal Protection
- Overload Protection
- Short Circuit Protection
- Anti-Thump Turn-On

PLA2270

High Performance 1000 Watt 2 Channel Bridgeable MOSFET Amplifier

- 500 Watts x 2 Output
- 1000 Watts x 1 Bridged Output
- Variable Hi/Lo Electronic Crossover Network
- Variable Bass Boost (0 - +18 dB @ 60Hz)
- Variable Input Level (Gain) Control
- Remote Turn On/Off
- Gold Plated RCA Inputs
- High Level MOLEX Input
- Power ON LED Indicator
- LED Protection Indicator
- Remote Bass Boost
- S/N Ratio: > 95 dB
- THD: <0.04%
- Thermal Protection
- Overload Protection
- Short Circuit Protection
- Anti-Thump Turn-On

PLA2370

High Performance 1400 Watt 2 Channel Bridgeable MOSFET Amplifier

- 700 Watts x 2 Output
- 1400 Watts x 1 Bridged Output
- Variable Hi/Lo Electronic Crossover Network
- Variable Bass Boost (0 - +18 dB @ 60Hz)
- Variable Input Level (Gain) Control
- Remote Turn On/Off
- Gold Plated RCA Inputs
- High Level MOLEX Input
- Power ON LED Indicator
- LED Protection Indicator
- Remote Bass Boost
- S/N Ratio: > 95 dB
- THD: <0.04%
- Thermal Protection
- Overload Protection
- Short Circuit Protection
- Anti-Thump Turn-On

2



PLA2470

High Performance 1600 Watt 2 Channel Bridgeable MOSFET Amplifier

- 800 Watts x 2 Output
- 1600W x 1 Bridged Output
- Variable Hi/Lo Electronic Crossover Network
- Variable Bass Boost (0 - +18 dB @ 60Hz)
- Variable Input Level (Gain) Control
- Remote Turn On/Off
- Gold Plated RCA Inputs
- High Level MOLEX Inputs
- Power ON LED Indicator
- LED Protection Indicator
- Remote Bass Boost
- S/N Ratio: > 95 dB
- THD: <0.04%
- Thermal Protection
- Overload Protection
- Short Circuit Protection
- Anti-Thump Turn-On
- Tri-Mode Configurable

PLA2570

High Performance 2000 Watt 2 Channel Bridgeable MOSFET Amplifier

- 1000 Watts x 2 Output
- 2000W x 1 Bridged Output
- Variable Hi/Lo Electronic Crossover Network
- Variable Bass Boost (0 - +18 dB @ 60Hz)
- Variable Input Level (Gain) Control
- Remote Turn On/Off
- Gold Plated RCA Inputs
- High Level MOLEX Inputs
- Power ON LED Indicator
- LED Protection Indicator
- Remote Bass Boost
- S/N Ratio: > 95 dB
- THD: <0.04%
- Thermal Protection
- Overload Protection
- Short Circuit Protection
- Anti-Thump Turn-On
- Tri-Mode Configurable

3

features and controls

2 ch amp PLA2170. PLA2270



PLA2170
PLA2270

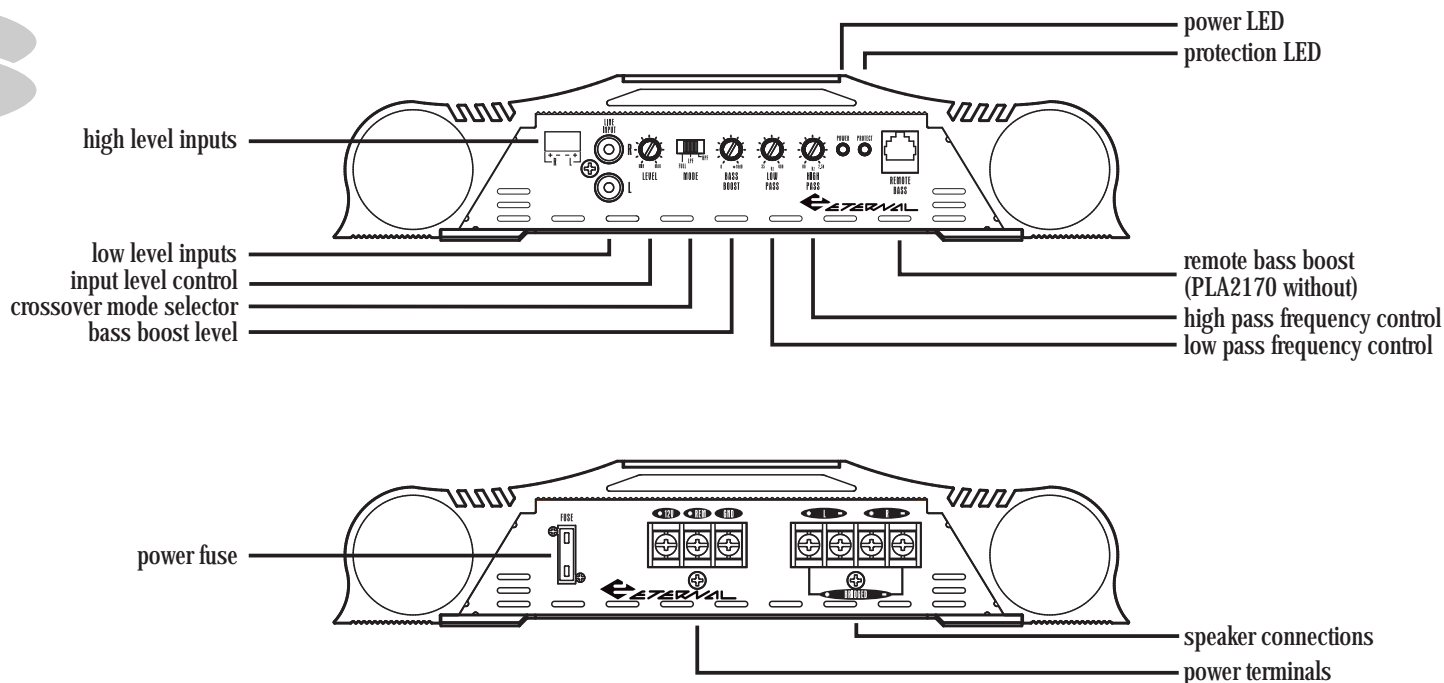

6

features and specifications

2 ch amp PLA2170. PLA2270



- crossover mode selector** when used with normal, full range systems, set this switch to "FULL." If you wish to use the internal crossover to power a driver of specific frequency range, use the "LOWPASS" or "HIGHPASS" settings.
- input level control** use this control to match the outputs of your head unit to the amplifier. Starting with your head unit set at about the 2 o'clock position, increase the amp level control until distortion begins to occur, and reduce slightly from this point.
- low pass frequency control** when the crossover selector switch is in "low pass" mode, this control sets the upper frequency limit for audio program sent to the speakers.
- high pass frequency control** when the crossover selector switch is in "high pass" mode, this control sets the lower frequency limit for audio program sent to the speakers.
- Remote Bass Boost** Plug in the Remote Bass Boost Control wire in here.
- bass boost level control** this control permits adjustment of the bass level up to an increase of approximately 18 dB.
- low level inputs** this amp features gold-plated RCA input jacks for high impedance input. Use these with car stereo output which uses RCA-type connector cables.
- high level inputs** if your car stereo lacks RCA-type output jacks, you may connect speaker output leads to these input connectors.
- power LED** this indicator is illuminated when power is applied.
- protection LED** this indicator is illuminated when built-in protection circuitry is activated.
- power fuse** the fuse protects the amplifier and your car's electrical system from short circuit conditions.
- power terminals** use these connectors to deliver power, ground and remote turn-on control to the amplifier.
- speaker connections** these terminals are 14K gold plated to guarantee high conductivity and minimum signal loss.

output power @ 14.4v DC, 1KHz

RMS Power @ 4 Ohms
RMS Power @ 2 Ohms
Maximum Power Output

PLA2170
2 channel amplifier

40 Watts x 2
70 Watts x 2
300 Watts x 2

PLA2270
2 channel amplifier

75 Watts x 2
110 Watts x 2
500 Watts x 2

frequency response

15 Hz-30 KHz

input impedance

low level inputs
high level inputs

10K Ohms
100 Ohms

input sensitivity

low level inputs
high level inputs

250mV
2.5V

power supply voltage

14.4V DC Neg. Ground (10.5-16V)

matching speaker impedance

stereo mode
bridged mode

2-4 Ohms
4-8 Ohms

maximum current draw

15A

20A

dimensions (W x H x L)

mm
inches

292 x 60 x 209
11.5 x 2.34 x 8.25

292 x 60 x 305
11.5 x 2.34 x 12

7

features and controls 2 ch amp PLA2370. PLA2470



PLA2370
PLA2470

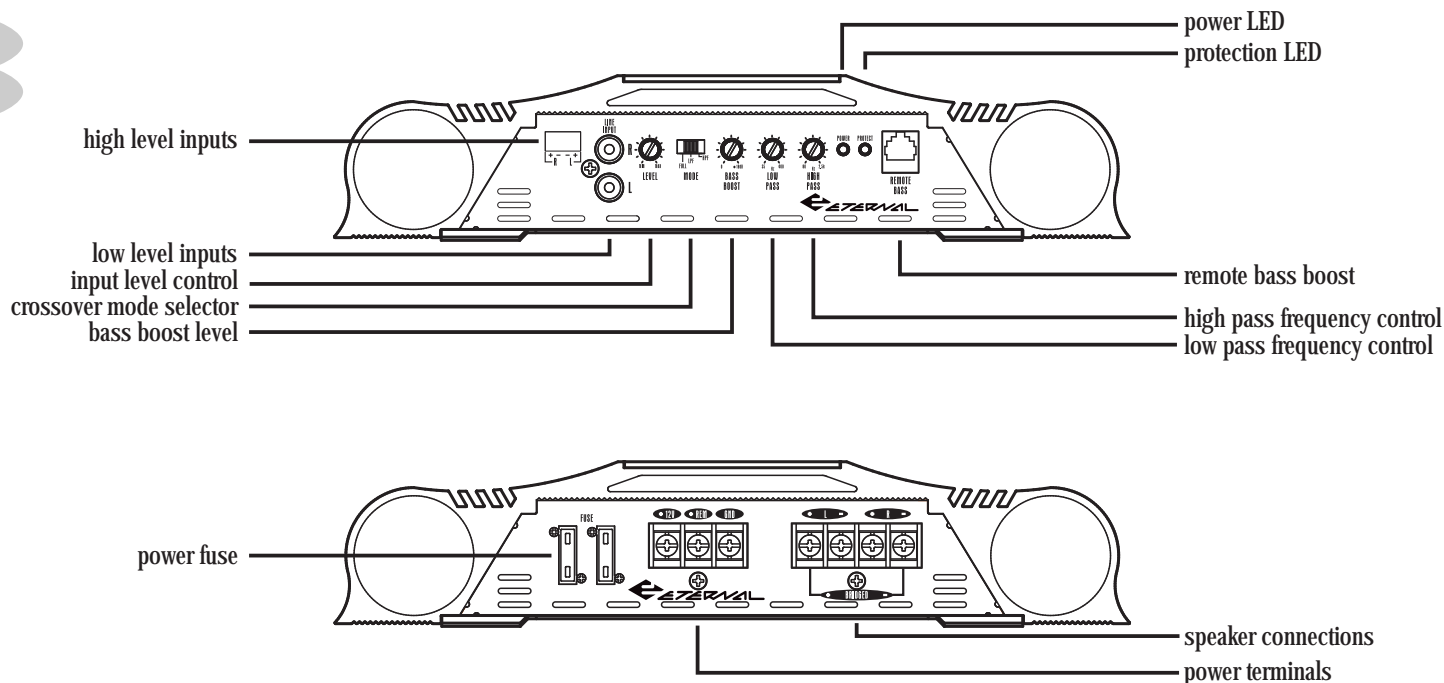

features and specifications 2 ch amp PLA2370. PLA2470



		PLA2370 2 channel amplifier	PLA2470 2 channel amplifier
crossover mode selector	when used with normal, full range systems, set this switch to "FULL." If you wish to use the internal crossover to power a driver of specific frequency range, use the "LOWPASS" or "HIGHPASS" settings.		
input level control	use this control to match the outputs of your head unit to the amplifier. Starting with your head unit set at about the 2 o'clock position, increase the amp level control until distortion begins to occur, and reduce slightly from this point.		
low pass frequency control	when the crossover selector switch is in "low pass" mode, this control sets the upper frequency limit for audio program sent to the speakers.		
high pass frequency control	when the crossover selector switch is in "high pass" mode, this control sets the lower frequency limit for audio program sent to the speakers.		
Remote Bass Boost	Plug in the Remote Bass Boost Control wire in here.		
bass boost level control	this control permits adjustment of the bass level up to an increase of approximately 18 dB.		
low level inputs	this amp features gold-plated RCA input jacks for high impedance input. Use these with car stereo output which uses RCA-type connector cables.		
high level inputs	if your car stereo lacks RCA-type output jacks, you may connect speaker output leads to these input connectors.		
power LED	this indicator is illuminated when power is applied.		
protection LED	this indicator is illuminated when built-in protection circuitry is activated.		
power fuse	the fuse protects the amplifier and your car's electrical system from short circuit conditions.		
power terminals	use these connectors to deliver power, ground and remote turn-on control to the amplifier.		
speaker connections	these terminals are 14K gold plated to guarantee high conductivity and minimum signal loss.		
output power @ 14.4v DC, 1KHz			
	RMS Power @ 4 Ohms	100 Watts x 2	150 Watts x 2
	RMS Power @ 2 Ohms	150 Watts x 2	220 Watts x 2
	Maximum Power Output	700 Watts x 2	800 Watts x 2
frequency response		15 Hz-30 KHz
input impedance			
	low level inputs	10K Ohms
	high level inputs	100 Ohms
input sensitivity			
	low level inputs	250mV
	high level inputs	2.5V
power supply voltage		14.4V DC Neg. Ground (10.5-16V)
matching speaker impedance			
	stereo mode	2-4 Ohms
	bridged mode	4-8 Ohms
maximum current draw		30A	50A
dimensions (W x H x L)			
	mm	292 x 60 x 400	292 x 60 x 432
	inches	11.5 x 2.34 x 15.75	11.5 x 2.34 x 17

PYLE

features and controls

2 ch amp PLA2570

ETERNAL

PLA2570

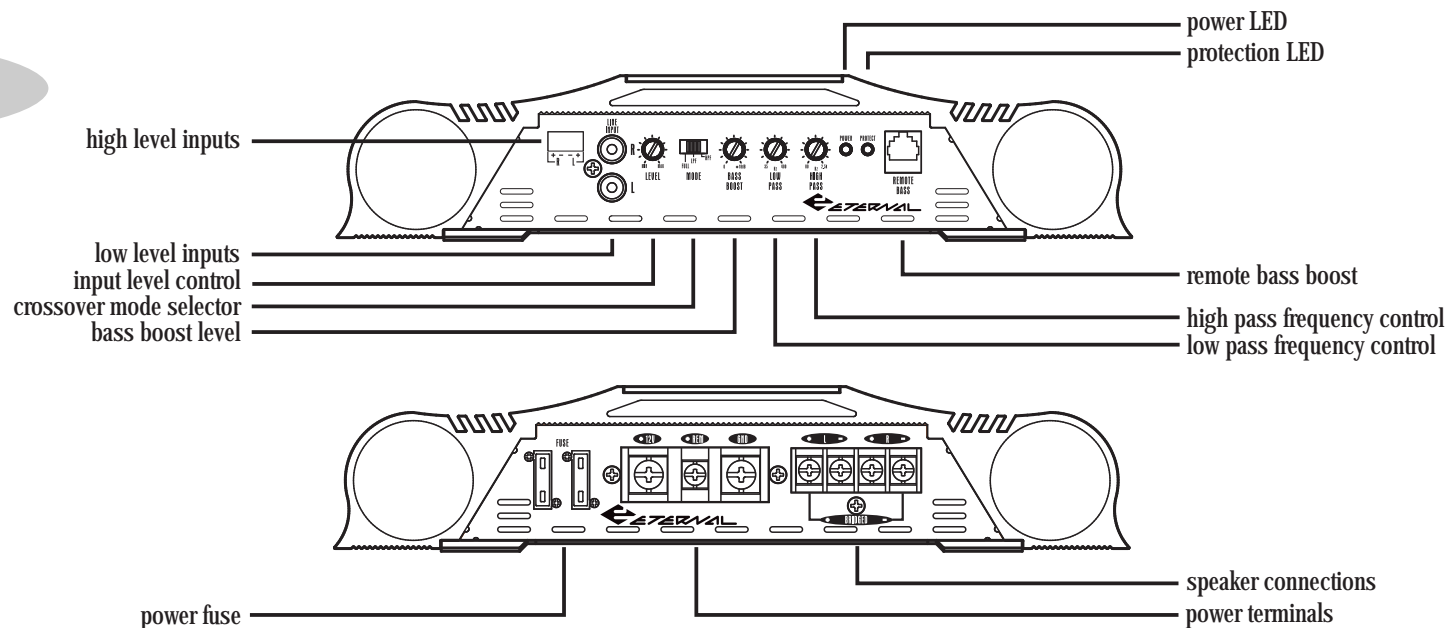

10

PYLE

features and specifications

2 ch amp PLA2570

ETERNAL

PLA2570
2 channel amplifier

- crossover mode selector** when used with normal, full range systems, set this switch to "FULL." If you wish to use the internal crossover to power a driver of specific frequency range, use the "LOWPASS" or "HIGHPASS" settings.
- input level control** use this control to match the outputs of your head unit to the amplifier. Starting with your head unit set at about the 2 o'clock position, increase the amp level control until distortion begins to occur, and reduce slightly from this point.
- low pass frequency control** when the crossover selector switch is in "low pass" mode, this control sets the upper frequency limit for audio program sent to the speakers.
- high pass frequency control** when the crossover selector switch is in "high pass" mode, this control sets the lower frequency limit for audio program sent to the speakers.
- Remote Bass Boost** Plug in the Remote Bass Boost Control wire in here.
- bass boost level control** this control permits adjustment of the bass level up to an increase of approximately 18 dB.
- low level inputs** this amp features gold-plated RCA input jacks for high impedance input. Use these with car stereo output which uses RCA-type connector cables.
- high level inputs** if your car stereo lacks RCA-type output jacks, you may connect speaker output leads to these input connectors.
- power LED** this indicator is illuminated when power is applied.
- protection LED** this indicator is illuminated when built-in protection circuitry is activated.
- power fuse** the fuse protects the amplifier and your car's electrical system from short circuit conditions.
- power terminals** use these connectors to deliver power, ground and remote turn-on control to the amplifier.
- speaker connections** these terminals are 14K gold plated to guarantee high conductivity and minimum signal loss.

output power @ 14.4v DC, 1KHz

RMS Power @ 4 Ohms
RMS Power @ 2 Ohms
Maximum Power Output

200 Watts x 2
285 Watts x 2
1000 Watts x 2

frequency response

15 Hz-30 KHz

input impedance

low level inputs
high level inputs

10K Ohms
100 Ohms

input sensitivity

low level inputs
high level inputs

250mV
2.5V

power supply voltage

14.4V DC Neg. Ground (10.5-16V)

matching speaker impedance

stereo mode
bridged mode

2-4 Ohms
4-8 Ohms

maximum current draw

60A

dimensions (W x H x L)

mm
inches

292 x 60 x 483
11.5 x 2.34 x 19

11

features and controls

4 ch amp PLA4170. PLA4270



PLA4170
PLA4270

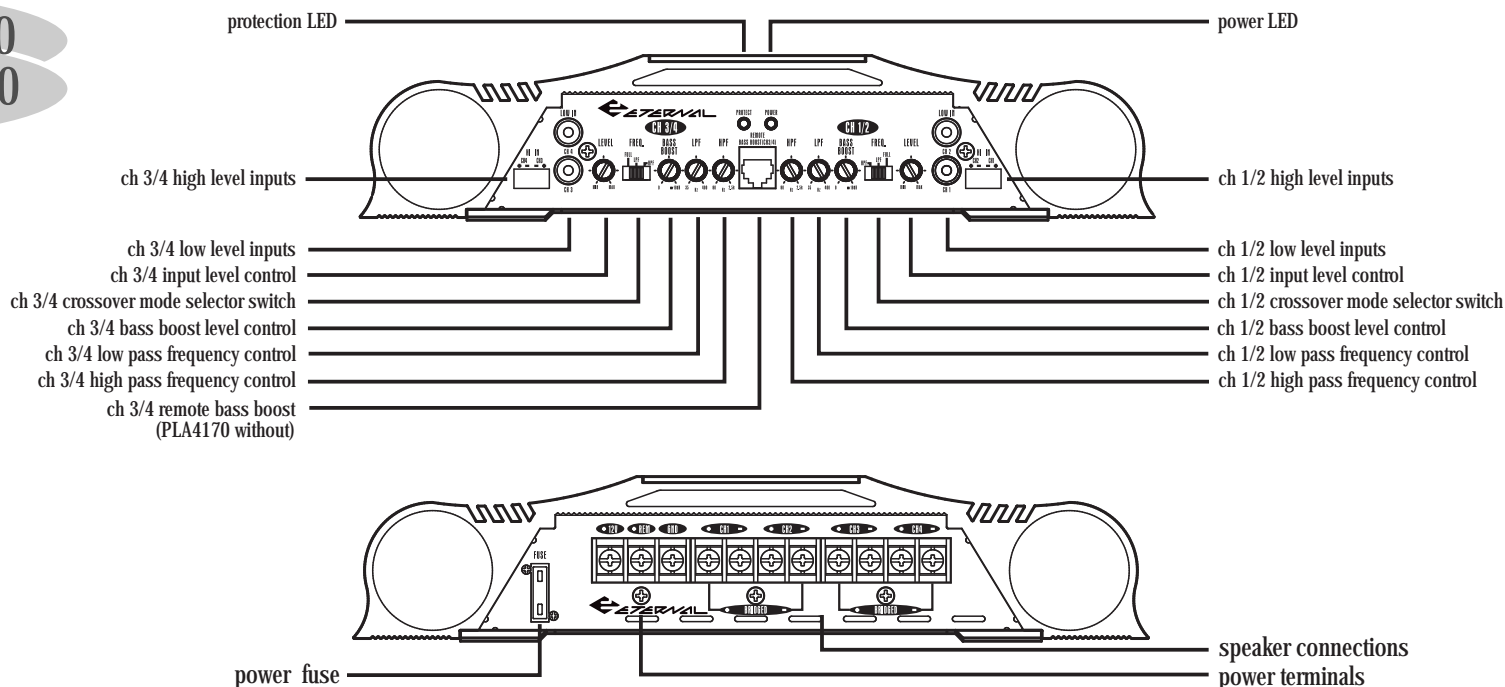

12

features and specifications

4 ch amp PLA4170. PLA4270



		PLA4170 4 channel amplifier	PLA4270 4 channel amplifier
crossover mode selector	when used with normal, full range systems, set this switch to "FULL." If you wish to use the internal crossover to power a driver of specific frequency range, use the "LOWPASS" or "HIGHPASS" settings.		
input level control	use this control to match the outputs of your head unit to the amplifier. Starting with your head unit set at about the 2 o'clock position, increase the amp level control until distortion begins to occur, and reduce slightly from this point.		
low pass frequency control	when the crossover selector switch is in "low pass" mode, this control sets the upper frequency limit for audio program sent to the speakers.		
high pass frequency control	when the crossover selector switch is in "high pass" mode, this control sets the lower frequency limit for audio program sent to the speakers.		
Remote Bass Boost	Plug in the Remote Bass Boost Control wire in here.		
bass boost level control	this control permits adjustment of the bass level up to an increase of approximately 18 dB.		
low level inputs	this amp features gold-plated RCA input jacks for high impedance input. Use these with car stereo output which uses RCA-type connector cables.		
high level inputs	if your car stereo lacks RCA-type output jacks, you may connect speaker output leads to these input connectors.		
power LED	this indicator is illuminated when power is applied.		
protection LED	this indicator is illuminated when built-in protection circuitry is activated.		
power fuse	the fuse protects the amplifier and your car's electrical system from short circuit conditions.		
power terminals	use these connectors to deliver power, ground and remote turn-on control to the amplifier.		
speaker connections	these terminals are 14K gold plated to guarantee high conductivity and minimum signal loss.		
output power @ 14.4v DC, 1KHz			
		<i>RMS Power @ 4 Ohms</i> 35 Watts x 4	75 Watts x 4
		<i>RMS Power @ 2 Ohms</i> 50 Watts x 4	110 Watts x 4
		<i>Maximum Power Output</i> 250 Watts x 4	400 Watts x 4
frequency response		15 Hz-30 KHz
input impedance			
	<i>low level inputs</i>	10K Ohms
	<i>high level inputs</i>	100 Ohms
input sensitivity			
	<i>low level inputs</i>	250mV
	<i>high level inputs</i>	2.5V
power supply voltage		14.4V DC Neg. Ground (10.5-16V)
matching speaker impedance			
	<i>stereo mode</i>	2-4 Ohms
	<i>bridged mode</i>	4-8 Ohms
maximum current draw		30A	40A
dimensions (W x H x L)			
	<i>mm</i>	292 x 60 x 305	292 x 60 x 432
	<i>inches</i>	11.5 x 2.34 x 12	11.5 x 2.34 x 17

13

PYLE

features and controls

4 ch amp PLA4370



PLA4370

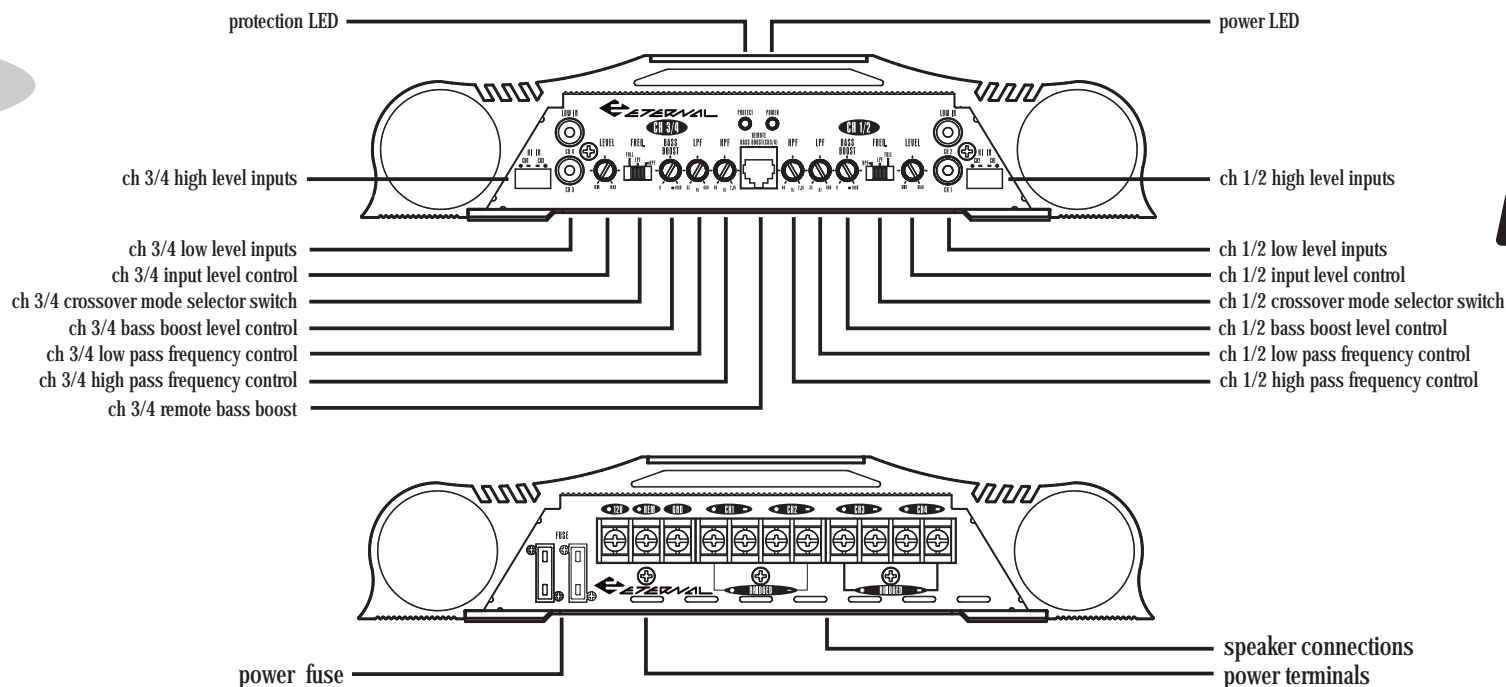

14

PYLE

features and specifications

4 ch amp PLA4370



PLA4370
4 channel amplifier

- crossover mode selector** when used with normal, full range systems, set this switch to "FULL." If you wish to use the internal crossover to power a driver of specific frequency range, use the "LOWPASS" or "HIGHPASS" settings.
- input level control** use this control to match the outputs of your head unit to the amplifier. Starting with your head unit set at about the 2 o'clock position, increase the amp level control until distortion begins to occur, and reduce slightly from this point.
- low pass frequency control** when the crossover selector switch is in "low pass" mode, this control sets the upper frequency limit for audio program sent to the speakers.
- high pass frequency control** when the crossover selector switch is in "high pass" mode, this control sets the lower frequency limit for audio program sent to the speakers.
- Remote Bass Boost** Plug in the Remote Bass Boost Control wire in here.
- bass boost level control** this control permits adjustment of the bass level up to an increase of approximately 18 dB.
- low level inputs** this amp features gold-plated RCA input jacks for high impedance input. Use these with car stereo output which uses RCA-type connector cables.
- high level inputs** if your car stereo lacks RCA-type output jacks, you may connect speaker output leads to these input connectors.
- power LED** this indicator is illuminated when power is applied.
- protection LED** this indicator is illuminated when built-in protection circuitry is activated.
- power fuse** the fuse protects the amplifier and your car's electrical system from short circuit conditions.
- power terminals** use these connectors to deliver power, ground and remote turn-on control to the amplifier.
- speaker connections** these terminals are 14K gold plated to guarantee high conductivity and minimum signal loss.

output power @ 14.4v DC, 1KHz

RMS Power @ 4 Ohms 100 Watts x 4
RMS Power @ 2 Ohms 150 Watts x 4
Maximum Power Output 500 Watts x 4

frequency response 15 Hz-30 KHz

input impedance
low level inputs 10K Ohms
high level inputs 100 Ohms

input sensitivity
low level inputs 250mV
high level inputs 2.5V

power supply voltage 14.4V DC Neg. Ground (10.5-16V)

matching speaker impedance
stereo mode 2-4 Ohms
bridged mode 4-8 Ohms

maximum current draw 50A

dimensions (W x H x L)
mm 292 x 60 x 483
inches 11.5 x 2.34 x 19

15

PYLE

ETERNAL

electrical connections

2 ch amps PLA2170. PLA2270. PLA2370. PLA2470. PLA2570

PLA2170
PLA2270
PLA2370
PLA2470
PLA2570

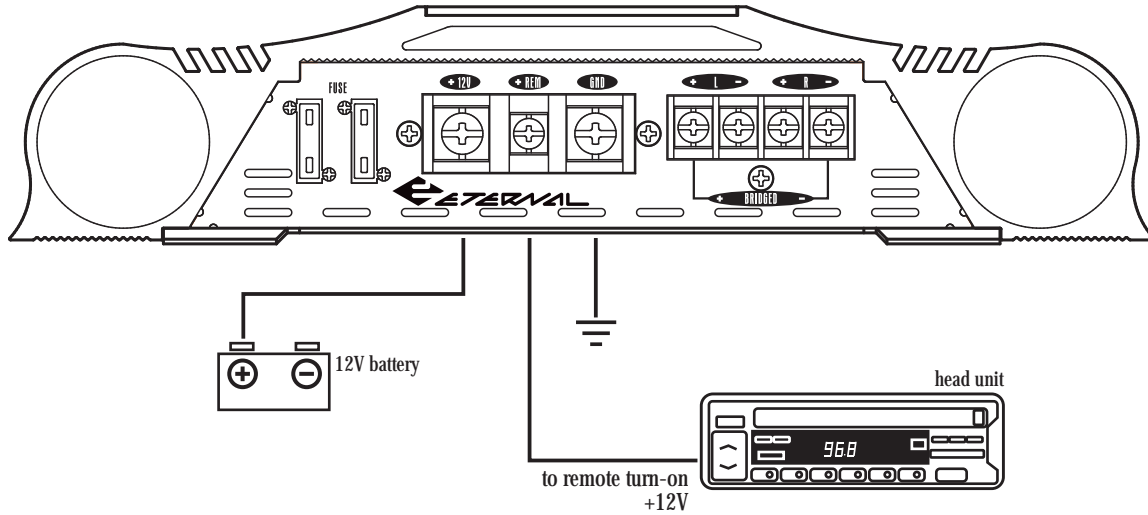

16

PYLE

ETERNAL

electrical connections

4 ch amps PLA4170. PLA4270. PLA4370

PLA4170
PLA4270
PLA4370

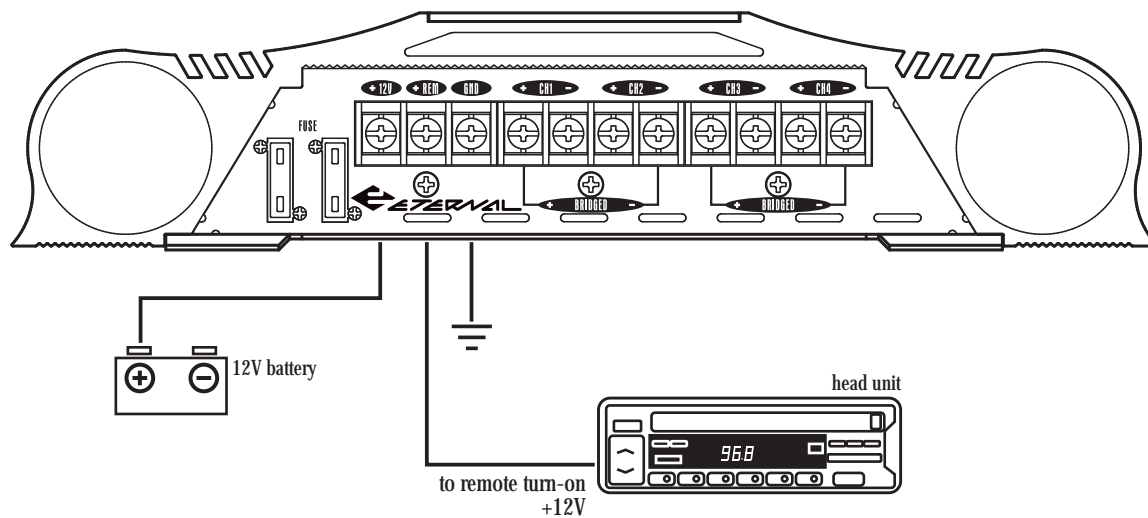

17

PYLE

ETERNAL

stereo input connections

2 ch amps PLA2170. PLA2270. PLA2370. PLA2470. PLA2570

using low level inputs

PLA2170
PLA2270
PLA2370
PLA2470
PLA2570

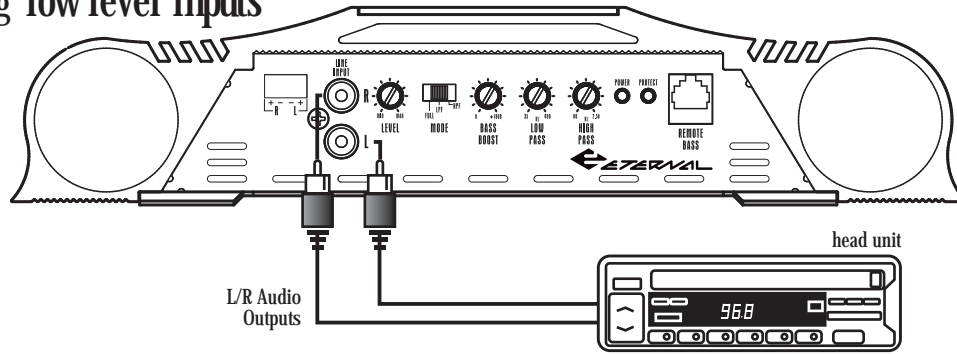

PLEASE NOTE If using high level inputs, do not use the low level RCA inputs at the same time!

18

using high level inputs

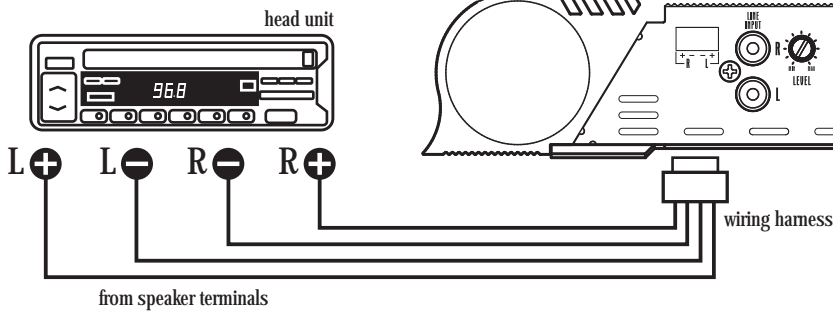

PYLE

ETERNAL

mono input connections

2 ch amps PLA2170. PLA2270. PLA2370. PLA2470. PLA2570

using low level inputs

PLA2170
PLA2270
PLA2370
PLA2470
PLA2570

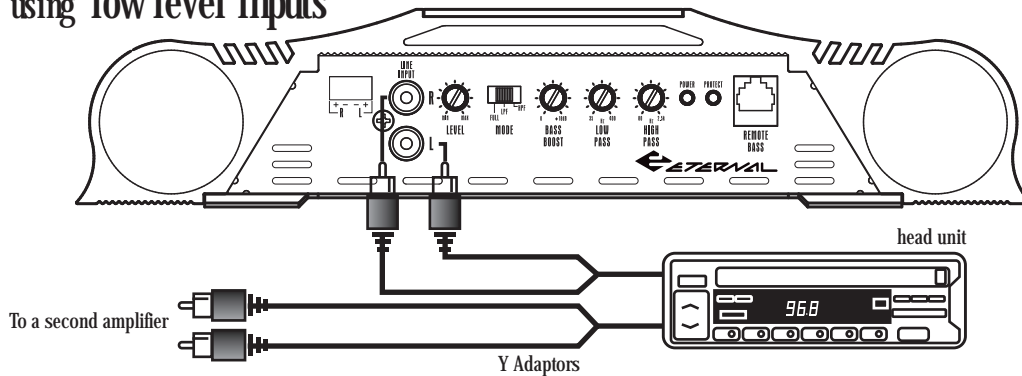

PLEASE NOTE If using high level inputs, do not use the low level RCA inputs at the same time!

19

using high level inputs

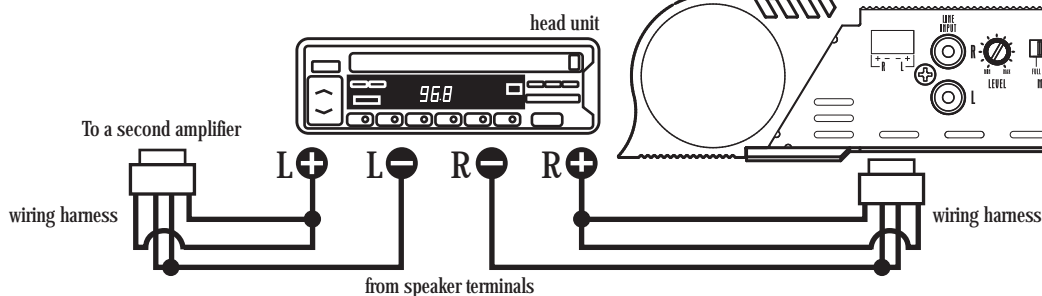

2/4 channel input connections

4 ch amps PLA4170. PLA4270. PLA4370



4 CH input connections using low level inputs

PLA4170
PLA4270
PLA4370

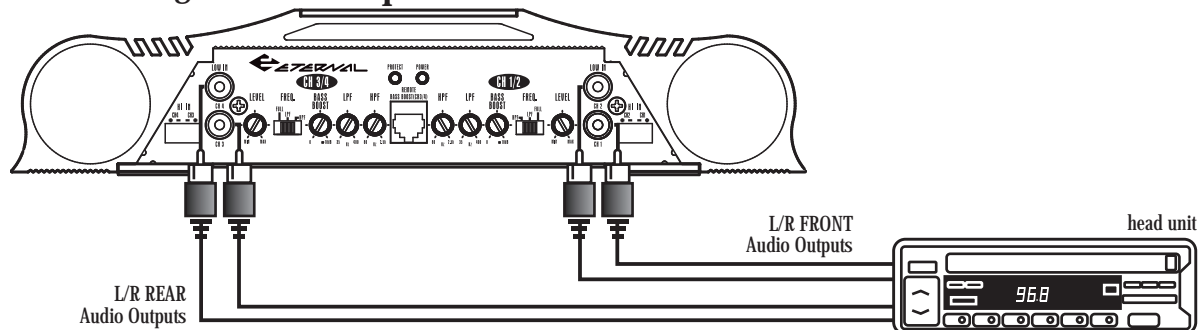

20

2 CH input connections using low level inputs

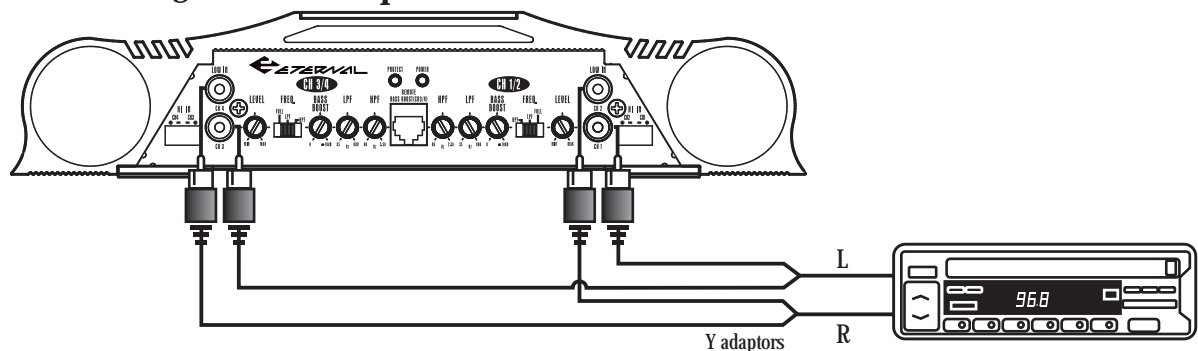

high level input connections

4 ch amps PLA4170. PLA4270. PLA4370



4 CH floating ground connections

PLA4170
PLA4270
PLA4370

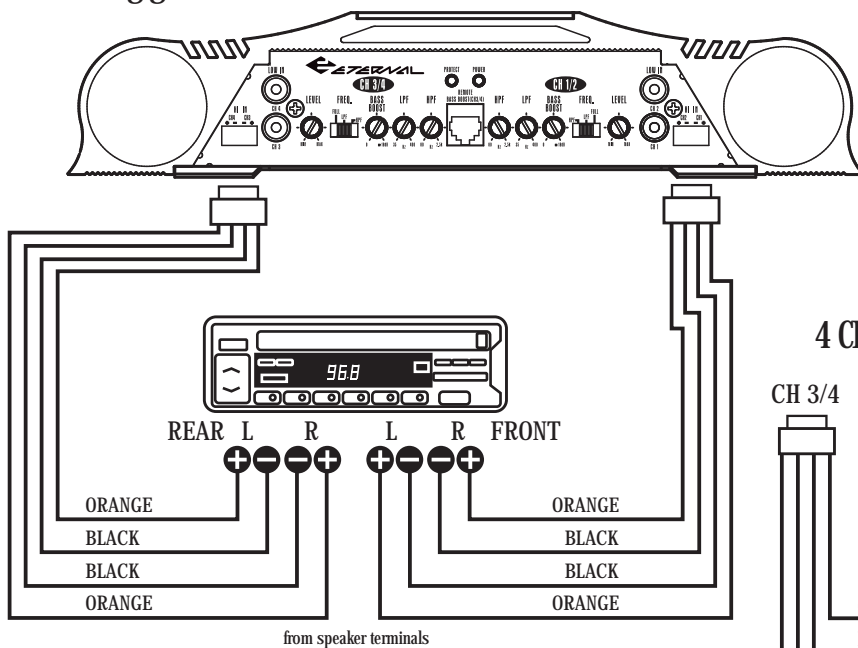

21

4 CH harness wiring for common ground connections

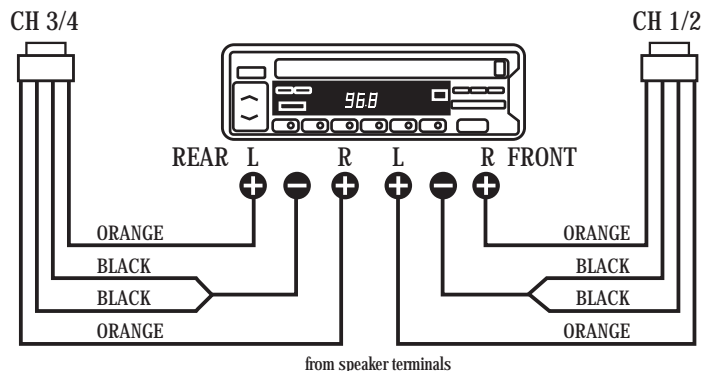

PLEASE NOTE! If using high level inputs, do not use the low level RCA inputs at the same time!

from speaker terminals

PYLE

ETERNAL

mono input connections

4 ch amps PLA4170. PLA4270. PLA4370

4 CH mono input connections using low level inputs

PLA4170
PLA4270
PLA4370

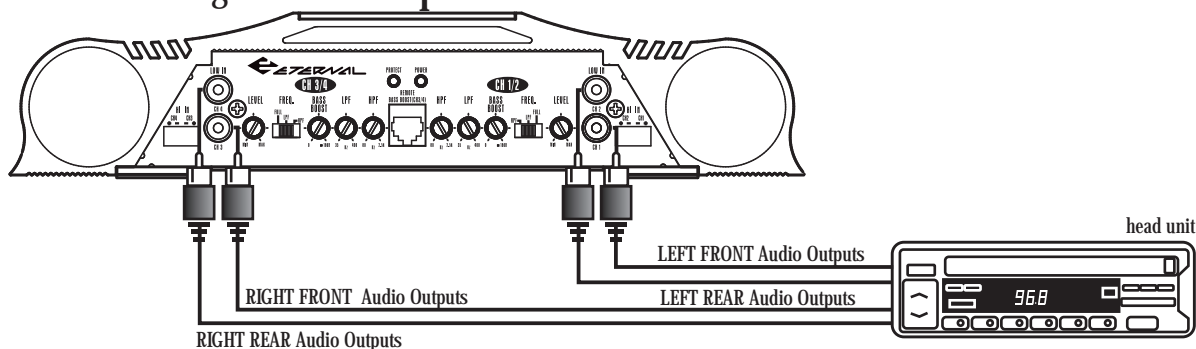

22

2 CH input connections using low level inputs

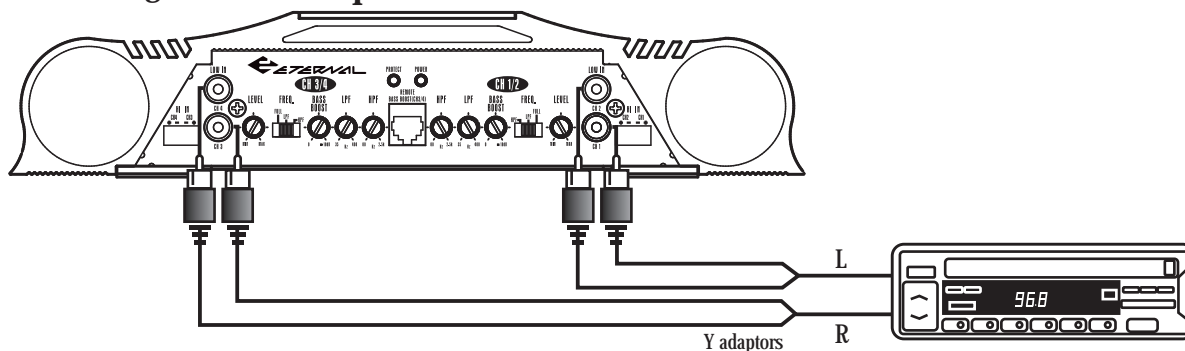

PYLE

ETERNAL

high level mono input connections

4 ch amps PLA4170. PLA4270. PLA4370

4 CH floating ground connections

PLA4170
PLA4270
PLA4370

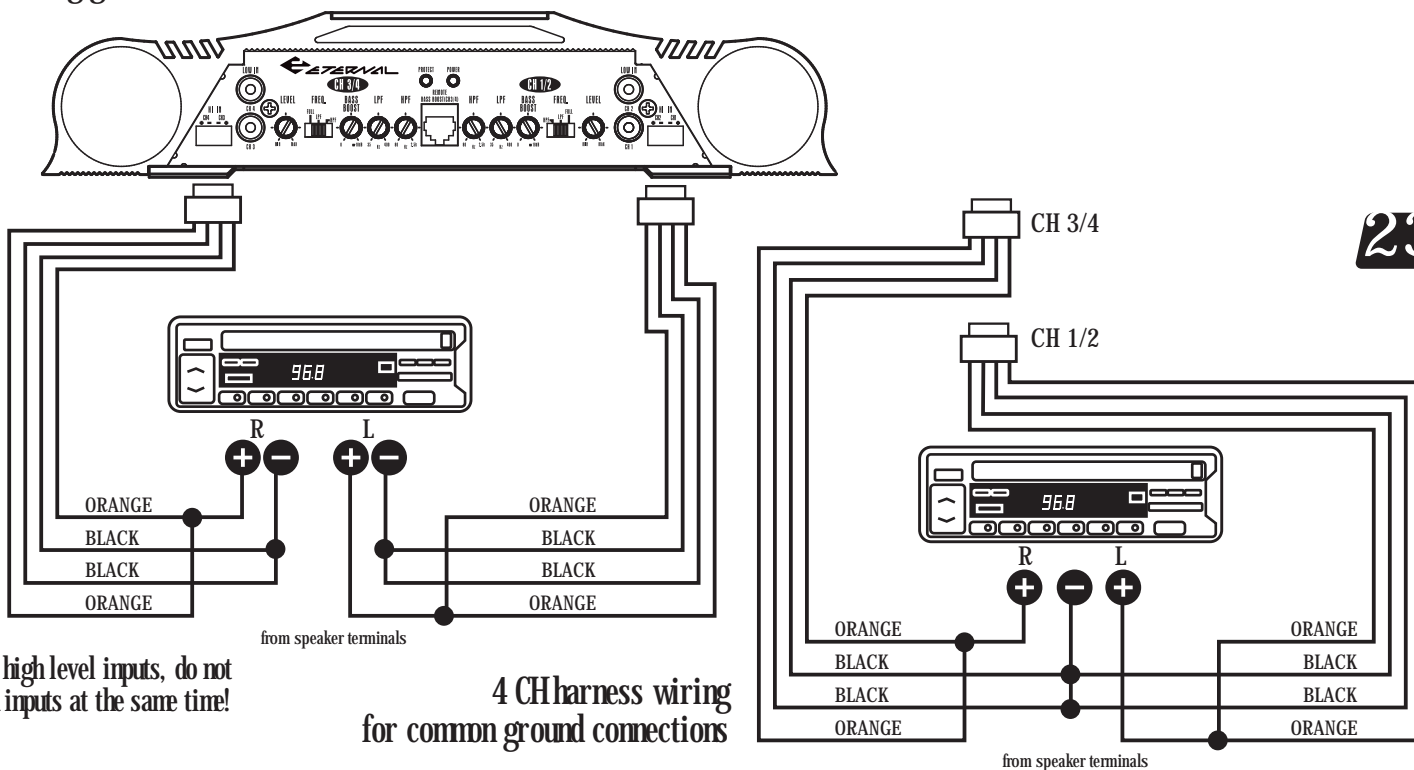

23

PLEASE NOTE If using high level inputs, do not use the low level RCA inputs at the same time!

4 CH harness wiring for common ground connections

PYLE

speaker connections

2 ch amps PLA2170. PLA2270. PLA2370. PLA2470. PLA2570

ETERNAL

Stereo Output Mode

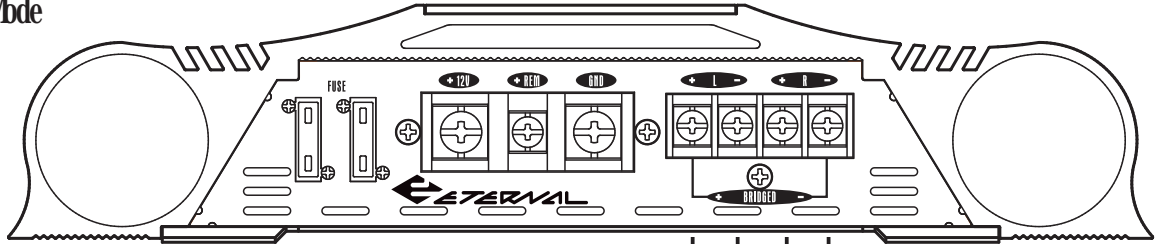

PLA2170
 PLA2270
 PLA2370
 PLA2470
 PLA2570

24

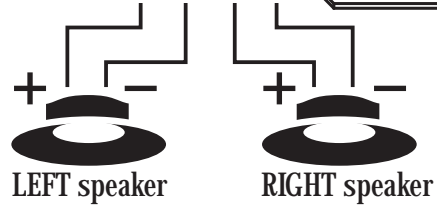

Bridged Mono Output Mode

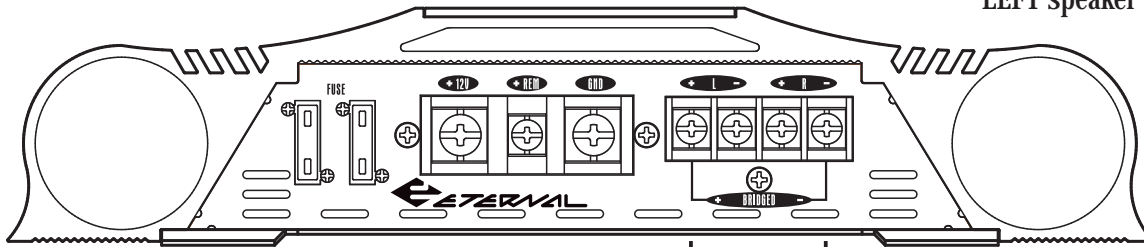

PYLE

speaker connections

4 ch amps PLA4170. PLA4270. PLA4370

ETERNAL

4 CH Output Mode

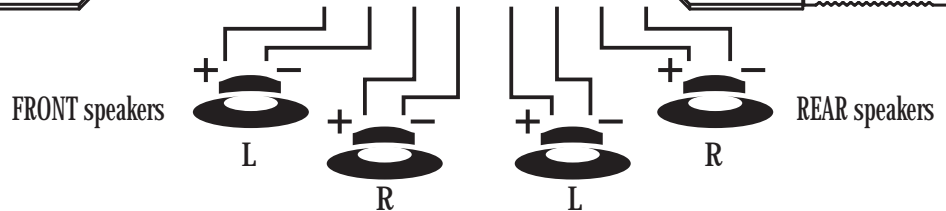
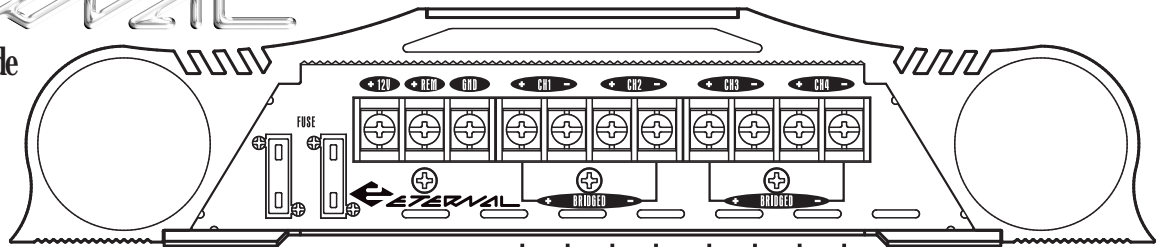

Bridged Dual Mono Output Mode

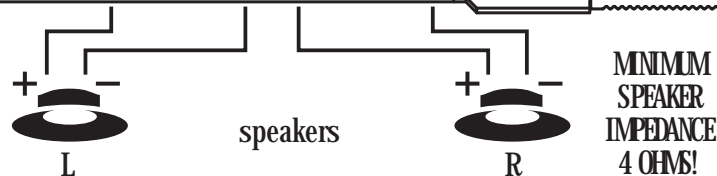
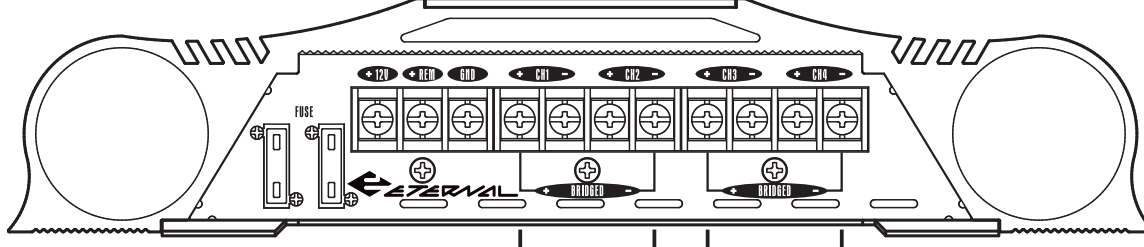

PLA4170
 PLA4270
 PLA4370

25

PYLE

speaker connections 4 ch amp PLA4170, PLA4270, PLA4370

ETERNAL

2 CH Stereo Output Mode with Mono Bridged Subwoofer Output

PLA4170
PLA4270
PLA4370

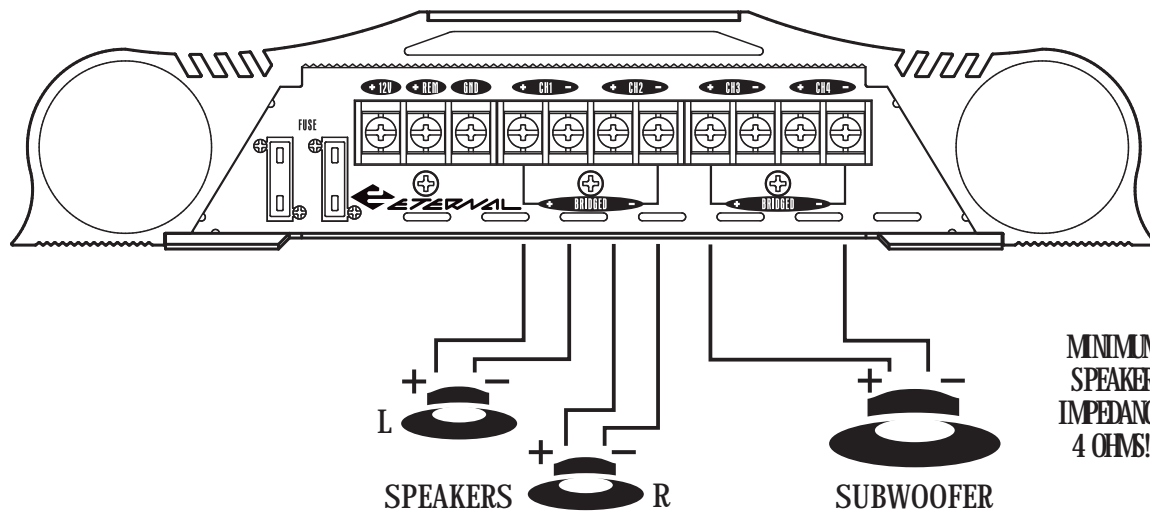

26

PYLE

mounting and installation

ETERNAL

mounting

Your new Pyle ETERNAL Series amplifier comes complete with all required mounting hardware. When determining a suitable location in your vehicle for the amp, please remember that it is a high-power electronic device capable of generating high heat.

For this reason, always choose a location in your vehicle which has low vibration, adequate ventilation, a minimum of dust, and no moisture. Be sure to mount the amp in such a manner as to allow reasonable airflow over the cooling fins.

Mark the location for the mounting screw holes by positioning the amp where you wish to install it and use a scribe (or one of the mounting screws) inserted in each of the mounting holes to mark the mounting surface. If the mounting surface is carpeted, measure the hole centers and mark with a felt tip pen.

Before attempting to drill the mounting holes, take note of any wires, lines or other devices in your vehicle which may be located behind the mounting surface! Then drill pilot holes in the mounting surface for the mounting screws and insert them. Tighten the screws securely.

27

wiring tips

When making electrical connections to your amplifier, please observe the following:

- Use at least 8 gauge wire for power and ground connections.
- Wire the amplifier directly to the car battery.
- For the ground connection, use the shortest possible wire to a good chassis ground point.
- Wire the Remote connection to the auto start lead of your head unit, equalizer or power antenna.

fuses

About power fuses:

Pyle ETERNAL Series amplifiers feature built-in fuse systems. These fuses protect both the amplifier and the electrical system in your vehicle from fault conditions. If you ever need to replace the fuse in your Pyle ETERNAL Series amp, use a fuse of exactly the same type and rating. A different type or rating of fuse may result in damage or fire.



troubleshooting

protection circuitry

The built-in protection circuitry in the Pyle Eternal amplifiers will disable the amplifier if it senses an input overload, a speaker short circuit, or extreme temperature conditions.

When the protection circuit is activated by any of these conditions, the Protection LED will be illuminated.

If this occurs, carefully inspect the system to determine the source of the problem.

- If the shutdown was a result of a thermal overload condition, allow the amplifier to cool down before attempting to restart it.
- If the shutdown was a result of an input overload, or speaker short circuit, be sure to correct the condition before restarting.

The amplifier can be restarted by turning the remote power OFF and then ON again.

No output.

Confirm that all terminal strip connections are secure and tight.

Check both in-line and built-in fuses. Both the +12V and the Remote terminals must have +12v referenced to chassis ground.

Confirm that the audio signal source (car radio, equalizer, etc.) is connected and is supplying output signal. To check if the amp is supplying signal, unplug the cables from the signal source (but leave them plugged into the amp). Briefly tap the center pin of each of the disconnected RCA plugs with your finger. This should produce a noise (feedback) in your speakers.

Only one channel works.

Confirm that all terminal strip connections are secure and tight.

Check the Balance control on the head unit (or other source) to verify that it is set to its midpoint.

28

If you are using the Low Level RCA input, reverse the input plugs at the amplifier (i.e., switch the L with the R). If the channels which is silent switches to the other side, the problem is either in the head unit/other source or the connecting cables.

Weak output.

Readjust the Input Level Control(s) to better suit the input signal.

Noise in the audio.

If the noise is a "whine" whose pitch follows the engine speed, confirm that the amplifier and any other signal sources (head unit, etc.) are properly grounded.

If the noise is a "clicking" or "popping" noise whose rate follows the engine speed, this usually means that the vehicle is equipped with resistor spark plugs and wires, or that the ignition is in need of service.

Check the routing of the speaker and input wires to make sure they are not adjacent to wires which interconnect lights and other accessories.

If the above steps fail to improve or clear noise interference, the system should be checked by a professional mobile audio installer.



notes

precautions

Do not operate the amplifier when it is unmounted. Attach all audio system components securely within the automobile to prevent damage, especially in an accident.

Do not mount this amplifier so that the wire connections are unprotected, or in a pinched condition, or likely to be damaged by nearby objects.

Before making or breaking power connections in your system, disconnect the vehicle battery. Confirm that your head unit or other equipment is turned off while connecting the input jacks and speaker terminals.

If you need to replace the power fuse, do so only with a fuse identical to that supplied with the amplifier. Using a fuse of a different type or rating may result in damage that isn't covered in the manufacturer's warranty.

29



PLA4170

High Performance 1000 Watt 4 Channel
Bridgeable MOSFET Amplifier

- 250 Watts x 4 Output.
- 500 W x 2 Bridged Output (250 W x 2 + 500 W x 1)
- Dual Variable Hi/Lo Electronic Crossover Network
- Dual Variable Bass Boost (0 - +18 dB @ 60Hz)
- Variable Input Level (Gain) Control
- Remote Turn On/Off
- Gold Plated RCA Inputs
- High Level MOLEX Inputs
- Power ON LED Indicator
- LED Protection Indicator
- S/N Ratio: > 95 dB
- THD: <0.04%
- Thermal Protection
- Overload Protection
- Short Circuit Protection
- Anti-Thump Turn-On
- Tri-Mode Configurable

PLA4270

High Performance 1600 Watt 4 Channel
Bridgeable MOSFET Amplifier

- 400 Watts x 4 Output
- 800 Watts x 2 Bridged Output (400 W x 2 + 800 W x 1)
- Dual Variable Hi/Lo Electronic Crossover Network
- Dual Variable Bass Boost (0 - +18 dB @ 60Hz)
- Variable Input Level (Gain) Control
- Remote Turn On/Off
- Gold Plated RCA Inputs
- High Level MOLEX Input
- Power ON LED Indicator
- LED Protection Indicator
- Remote Bass Boost
- S/N Ratio: > 95 dB
- THD: <0.04%
- Thermal Protection
- Overload Protection
- Short Circuit Protection
- Anti-Thump Turn-On



PLA4370

High Performance 2000 Watt 4 Channel
Bridgeable MOSFET Amplifier

- 500 Watts x 4 Output
- 1000 Watts x 2 Bridged Output (500 W x 2 + 1000 W x 1)
- Dual Variable Hi/Lo Electronic Crossover Network
- Dual Variable Bass Boost (0 - +18 dB @ 60Hz)
- Variable Input Level (Gain) Control
- Remote Turn On/Off
- Gold Plated RCA Inputs
- High Level MOLEX Input
- Power ON LED Indicator
- LED Protection Indicator
- Remote Bass Boost
- S/N Ratio: > 95 dB
- THD: <0.04%
- Thermal Protection
- Overload Protection
- Short Circuit Protection
- Anti-Thump Turn-On

Free Manuals Download Website

<http://myh66.com>

<http://usermanuals.us>

<http://www.somanuals.com>

<http://www.4manuals.cc>

<http://www.manual-lib.com>

<http://www.404manual.com>

<http://www.luxmanual.com>

<http://aubethermostatmanual.com>

Golf course search by state

<http://golfingnear.com>

Email search by domain

<http://emailbydomain.com>

Auto manuals search

<http://auto.somanuals.com>

TV manuals search

<http://tv.somanuals.com>