

OWNER'S MANUAL —
Please read before using this equipment.

14-1132

Your RadioShack Voice-Activated Cassette Recorder provides time-tested recording convenience in an affordable package. The recorder's voice-activation feature lets you record only when there is sound, providing hands-free operation while recording. The built-in microphone is sensitive enough for the boardroom, a seminar, or a lecture hall. And your recorder is small enough to fit in your briefcase or purse, so it can go wherever you go.

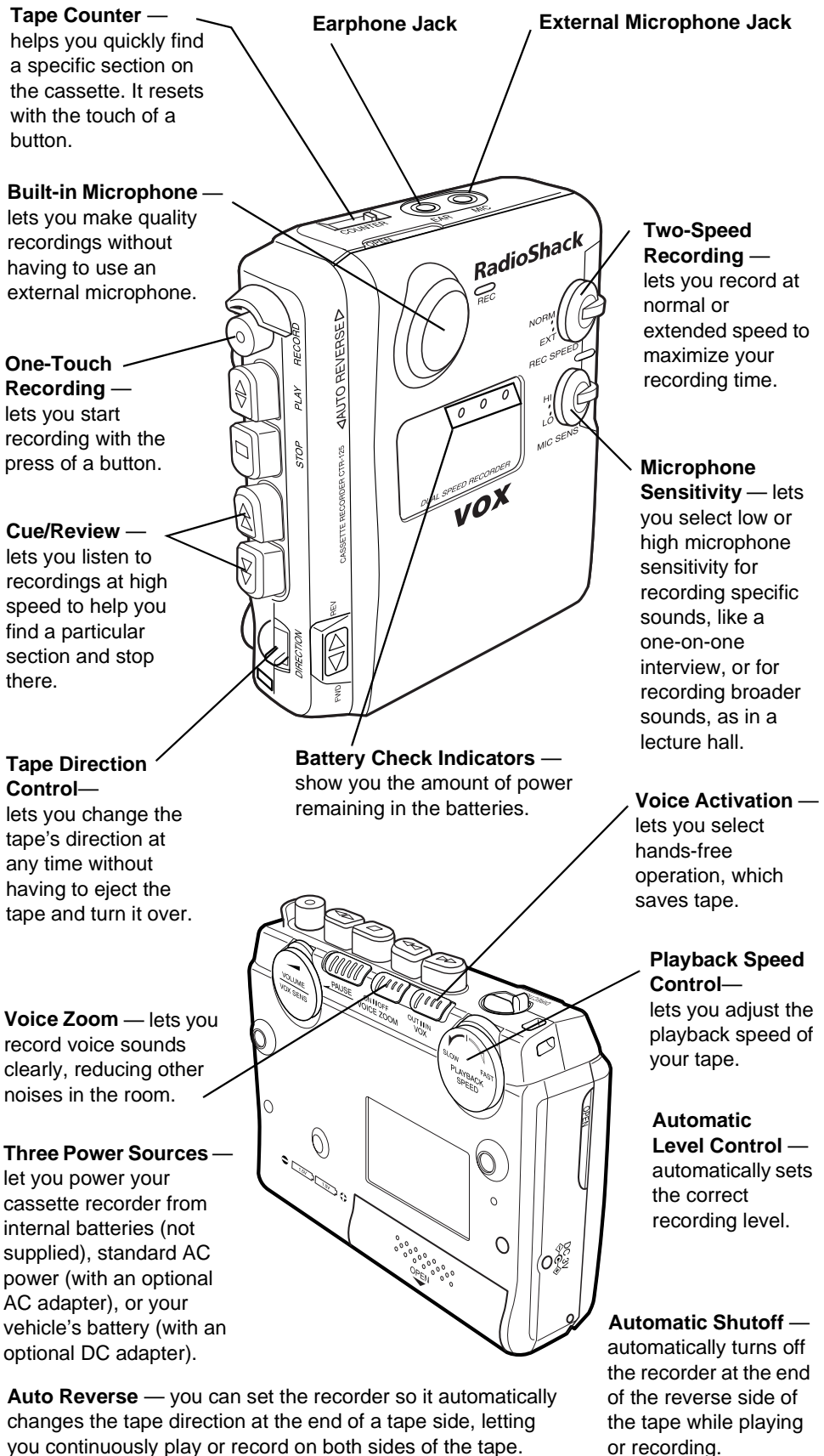

Tape Counter — helps you quickly find a specific section on the cassette. It resets with the touch of a button.

Built-in Microphone — lets you make quality recordings without having to use an external microphone.

One-Touch Recording — lets you start recording with the press of a button.

Cue/Review — lets you listen to recordings at high speed to help you find a particular section and stop there.

Tape Direction Control — lets you change the tape's direction at any time without having to eject the tape and turn it over.

Voice Zoom — lets you record voice sounds clearly, reducing other noises in the room.

Three Power Sources — let you power your cassette recorder from internal batteries (not supplied), standard AC power (with an optional AC adapter), or your vehicle's battery (with an optional DC adapter).

Auto Reverse — you can set the recorder so it automatically changes the tape direction at the end of a tape side, letting you continuously play or record on both sides of the tape.

Earphone Jack

External Microphone Jack

Two-Speed Recording — lets you record at normal or extended speed to maximize your recording time.

Microphone Sensitivity — lets you select low or high microphone sensitivity for recording specific sounds, like a one-on-one interview, or for recording broader sounds, as in a lecture hall.

Battery Check Indicators — show you the amount of power remaining in the batteries.

Voice Activation — lets you select hands-free operation, which saves tape.

Playback Speed Control — lets you adjust the playback speed of your tape.

Automatic Level Control — automatically sets the correct recording level.

Automatic Shutoff — automatically turns off the recorder at the end of the reverse side of the tape while playing or recording.

! IMPORTANT !

If an icon appears at the end of a paragraph, go to the box on that page with the corresponding icon for pertinent information.

— Warning — Important — Note — Caution — Hint



WARNING

Dispose of old batteries promptly and properly. Do not burn or bury them.

CAUTION

- Use only fresh batteries of the required size and recommended type.
- Do not mix old and new batteries, different types of batteries (standard, alkaline, or rechargeable), or rechargeable batteries of different capacities.
- If you do not plan to use the recorder with batteries for a month or more, remove the batteries. Batteries can leak chemicals that can destroy electronic parts.



You must use a Class 2 power source that supplies 3V DC and delivers at least 400 mA.

Its center tip must be set to positive and its plug must fit the recorder's DC 3V jack. Using an adapter that does not meet these specifications could damage the recorder or the adapter.

- Always connect the AC or DC adapter to the recorder before you connect it to AC power or the power source. When you finish, disconnect the adapter from AC power or the power source before you disconnect it from the recorder.

! IMPORTANT !

The EPA certified RBRC[®] Battery Recycling Seal on the nickel-cadmium (Ni-Cd) battery indicates

RadioShack is voluntarily participating in an industry program to collect and recycle these batteries at the end of their useful life, when taken out of service in the United States or Canada. The RBRC program provides a convenient alter-native to placing used Ni-Cd batteries into the trash or the municipal waste stream, which may be illegal in your area. Please call 1-800-THE-SHACK (1-800-843-7422) for information on Ni-Cd battery recycling and disposal bans/restrictions in your area. RadioShack's involvement in this program is part of the company's commitment to preserving our environment and conserving our natural resources.



NOTE

Connecting Power

Connecting an AC or DC adapter automatically disconnects internal batteries.

Connecting an Earphone/ External Microphone/ Wrist Strap

- You can also use an earphone during recording to listen to what the recorder is picking up through the internal or an external microphone. (See "Operation" on Page 3)
- Connecting an external microphone automatically disconnects the built-in microphone.
- Your local RadioShack store carries a wide selection of earphones and microphones.

PREPARATION

Connecting Power

You can power your recorder using internal batteries (not supplied), AC power (with an optional 3V, 400 mA AC adapter), or vehicle battery power (with an optional 3V, 400 mA DC adapter).

① Set the adapter's voltage switch to 3V.

④ Plug the AC adapter into a standard AC outlet or the DC adapter into your vehicle's cigarette lighter socket.

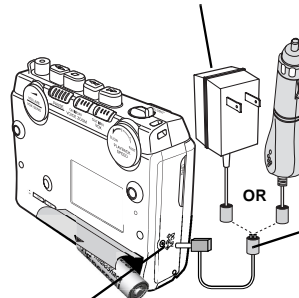

② Insert the Adaptaplug into the adapter's cord, with the tip set to positive.

③ Insert the plug into the recorder's DC 3V jack.

- lights when the batteries are full.
- lights when the batteries are medium
- lights when the batteries are low. Replace or recharge both batteries.

Size A Adaptaplug (not supplied)

Connecting an Earphone/External Microphone/Wrist Strap

You can use an optional earphone with a 1/8-inch (3.5-mm) plug to listen to a tape in privacy.

You can connect an external microphone (not supplied) with a 1/8-inch (3.5-mm) plug to the recorder's MIC jack.

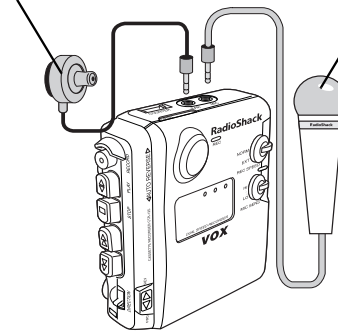

Attach the supplied wrist strap to the recorder to make it easier to carry and to reduce the risk of accidentally dropping it.

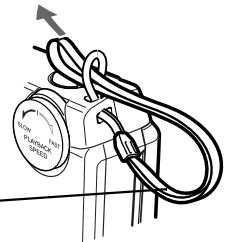

Loading a Tape

Use only normal bias (Type I) tapes of less than 90 minutes in this recorder. If you record on metal or high-bias tapes, the recorded sound will not erase properly. We do not recommend using tapes 90 minutes or longer because they are thin and can easily tangle.

Take up any slack in the tape by turning the cassette's hub with a pencil. Do not touch the exposed tape.

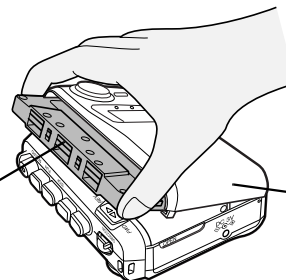

Open the cassette compartment door by pulling it up.

Insert a cassette into the door's tape guides with the cassette's open edge facing up, then close the door.

OPERATION

Playing a Tape

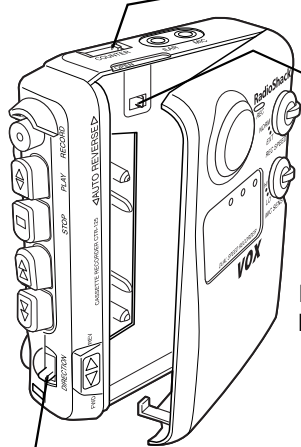

Use the tape counter to keep track of the tape position during recording or playback. Before playing a tape, press the tape counter reset button to set the counter to 000.

Set the auto reverse switch inside the cassette compartment to (one-time playback) or (continuous) playback. One-time playback plays one side of the tape to its end, then automatically reverses the tape's playback direction, plays the reverse side of the tape, then automatically stops.

Insert a tape then press **PLAY**. The button locks down and the tape plays.

To stop the tape, press **STOP**.

To stop play momentarily, slide **PAUSE** in the direction of the arrow. Slide **PAUSE** to the other position to resume play.

Adjust **VOLUME** to the desired listening level.

Fast forward

Rewind

Switch **DIRECTION** to **FWD** to play the side of the cassette facing out, or to **REV** to play the side facing in.

Turn **PLAYBACK SPEED** toward **FAST** to play the tape more quickly or toward **SLOW** to play it more slowly.

Recording

Use the built-in microphone or an optional external microphone to record.

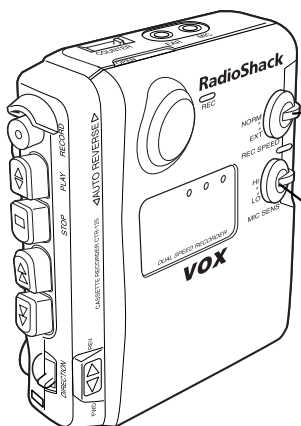

Set **REC SPEED** to **NORM** for normal recording or to **EXT** for extended recording (twice the normal recording time). When **REC SPEED** is set to **EXT**, the recorder puts the recording in half the space used during normal speed.

Set **MIC SENS** to **LO** (low) when the sound source is nearby, or to **HI** (high) when the sound source is far away.

Press **RECORD** when you want to begin recording. **RECORD** and **PLAY** automatically lock down. If **VOX** is set to **OUT**, recording begins immediately. If **VOX** is set to **IN**, recording begins when the recorder picks up sound.

If you set **VOX** to **IN**, adjust **VOX SENS** to set the sound level at which recording begins. When you adjust **VOX SENS** higher, softer sounds start **VOX** recording. When you adjust **VOX SENS** lower, louder sounds start **VOX** recording.

Slide **VOICE ZOOM** to **ON** to record specific voices without background interference. The recorder cuts off higher and lower frequency signals (background noise) and enhances the mid-range.

Set **VOX** to **OUT** to manually start and stop recording, or to **IN** to use voice-activated recording. When **VOX** is set to **IN**, recording begins when the recorder picks up sound and stops a few seconds after the sound stops.

To stop recording before it automatically stops, press **STOP**.

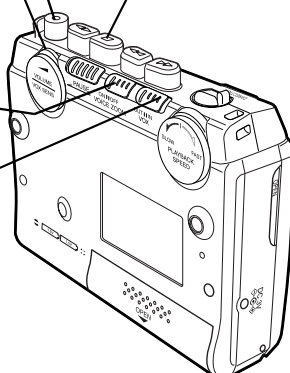

Listening Safely

To protect your hearing, follow these guidelines when you use an earphone.

- Set the volume to the lowest setting before you begin listening. After you begin listening, adjust the volume to a comfortable level.
- Do not listen at extremely high volume levels. Extended high-volume listening can lead to permanent hearing loss.
- Once you set the volume, do not increase it. Over time, your ears adapt to the volume level, so a volume level that does not cause discomfort might still damage your hearing.

Traffic Safety

Do not wear an earphone while operating a motor vehicle or riding a bicycle. This can create a traffic hazard and could be illegal in some areas.

Even though some earphones let you hear some outside sounds when listening at normal volume levels, they still can present a traffic hazard.

CAUTION

Recording

If you load a cassette with the erase-protection tabs broken off, do not try to force down **RECORD**. This can damage the recording mechanism.

NOTE

Playing a Tape

- If you set **DIRECTION** to **REV**, the recorder plays only the reverse side and stops at the end of that side.
- If you move **DIRECTION** from **REV** to **FWD** during playback, the recorder stops.
- Continuous playback: plays both sides of the tape continuously until you press **STOP**.
- Set **REC SPEED** to **NORM** for tapes that have been prerecorded on other recorders or recorded with the normal record setting on this recorder. Or set **REC SPEED** to **EXT** for tapes that have been recorded with the extended record setting on this recorder.

Recording

- The recorder records on one side of the tape, automatically reverses the tape's direction, records on the reverse side of the tape, then automatically stops.
- You can use an earphone (not supplied) to monitor a recording in progress.
- To pause recording, slide **PAUSE** in the direction of the arrow. To resume recording, slide **PAUSE** to the other position.
- Voice-activated recording saves power and tape if there are long or frequent pauses in the material you are recording.
- Tapes recorded at **EXT** can play only on this recorder or on another recorder that has the extended recording feature.

CAUTION

Preventing Accidental Erasure

Removing the erase-protection tabs does not prevent a bulk tape eraser from erasing a cassette tape.

Restoring Tape Tension and Sound Quality

Be careful not to damage the cassette when tapping it. Do not touch the exposed tape or allow any sharp object near the cassette.

NOTE

Using Fast Forward and Rewind

- You can also rewind or fast-forward during playback to help you locate a specific portion of the tape (for example, if you are listening for a particular speech, statement or other audio cue). While holding it down, you hear the tape at a faster speed. To return to normal playback, release the button.
- The recorder does not automatically stop when it reaches the end of the tape. To protect the tape after the tape has fully wound to either end, press **STOP** to release fast-forward or rewind.

Erasing Tapes

If you use metal or high-bias type tape, the recorded sound may not be erased properly.

CLEANING THE TAPE-HANDLING PARTS

Dirt, dust, or particles from the tape's coating can accumulate on the tape heads and other parts the tape touches. This can greatly reduce the performance of the recorder. After every 20 hours of operation, follow these steps to clean the tape-handling parts or use a RadioShack cassette deck cleaning kit.

1. Remove the batteries and disconnect any other power source.
2. Open the cassette compartment door and press **PLAY** to expose the tape-handling parts.
3. Use a cotton swab dipped in denatured alcohol or tape head cleaning solution to clean the record/playback head, pinch rollers, tape guides, and capstans.
4. When you finish cleaning, press **STOP** and close the cassette compartment door. Then reconnect power.

ERASING TAPES

If you record on a previously recorded tape, you replace the old recording with the new one. If you need to quickly erase an entire tape, you might prefer to use a bulk eraser (available at your local RadioShack store).

PREVENTING ACCIDENTAL ERASURE

Cassettes have two erase-protection tabs - one for each side. When a tab is in place, you can record on that side.

To prevent accidental erasure of a tape recording, use a screwdriver to remove one or both of the cassette tape's erase-protection tabs. This prevents **RECORD** from being pressed. If you later decide to record on a tape side after you have removed its erase-protection tab, place a piece of strong plastic tape over that side's erase-protection hole. Be sure you cover only the hole originally covered by the erase-protection tab.

RESTORING TAPE TENSION AND SOUND QUALITY

After you play a cassette tape several times, the tape might become tightly wound on the reels. This can cause playback sound quality to deteriorate. To restore the sound quality, fast-forward the tape from the beginning to the end of one side, then completely rewind it. Then loosen the tape reels by gently tapping each side of the cassette's outer shell on a flat surface.

CARE

Keep the recorder dry; if it gets wet, wipe it dry immediately. Use and store the recorder only in normal temperature environments. Handle the recorder carefully; do not drop it. Keep the recorder away from dust and dirt, and wipe it with a damp cloth occasionally to keep it looking new.

Limited Ninety-Day Warranty

This product is warranted by RadioShack against manufacturing defects in material and workmanship under normal use for ninety (90) days from the date of purchase from RadioShack company-owned stores and authorized RadioShack franchisees and dealers. EXCEPT AS PROVIDED HEREIN, RadioShack MAKES NO EXPRESS WARRANTIES AND ANY IMPLIED WARRANTIES, INCLUDING THOSE OF MERCHANTABILITY AND FITNESS FOR A PARTICULAR PURPOSE, ARE LIMITED IN DURATION TO THE DURATION OF THE WRITTEN LIMITED WARRANTIES CONTAINED HEREIN. EXCEPT AS PROVIDED HEREIN, RadioShack SHALL HAVE NO LIABILITY OR RESPONSIBILITY TO CUSTOMER OR ANY OTHER PERSON OR ENTITY WITH RESPECT TO ANY LIABILITY, LOSS OR DAMAGE CAUSED DIRECTLY OR INDIRECTLY BY USE OR PERFORMANCE OF THE PRODUCT OR ARISING OUT OF ANY BREACH OF THIS WARRANTY, INCLUDING, BUT NOT LIMITED TO, ANY DAMAGES RESULTING FROM INCONVENIENCE, LOSS OF TIME, DATA, PROPERTY, REVENUE, OR PROFIT OR ANY INDIRECT, SPECIAL, INCIDENTAL, OR CONSEQUENTIAL DAMAGES, EVEN IF RadioShack HAS BEEN ADVISED OF THE POSSIBILITY OF SUCH DAMAGES.

Some states do not allow limitations on how long an implied warranty lasts or the exclusion or limitation of incidental or consequential damages, so the above limitations or exclusions may not apply to you.

In the event of a product defect during the warranty period, take the product and the RadioShack sales receipt as proof of purchase date to any RadioShack store. RadioShack will, at its option, unless otherwise provided by law: (a) correct the defect by product repair without charge for parts and labor; (b) replace the product with one of the same or similar design; or (c) refund the purchase price. All replaced parts and products, and products on which a refund is made, become the property of RadioShack. New or reconditioned parts and products may be used in the performance of warranty service. Repaired or replaced parts and products are warranted for the remainder of the original warranty period. You will be charged for repair or replacement of the product made after the expiration of the warranty period.

This warranty does not cover: (a) damage or failure caused by or attributable to acts of God, abuse, accident, misuse, improper or abnormal usage, failure to follow instructions, improper installation or maintenance, alteration, lightning or other incidence of excess voltage or current; (b) any repairs other than those provided by a RadioShack Authorized Service Facility; (c) consumables such as fuses or batteries; (d) cosmetic damage; (e) transportation, shipping or insurance costs; or (f) costs of product removal, installation, set-up service adjustment or reinstallation.

This warranty gives you specific legal rights, and you may also have other rights which vary from state to state.
RadioShack Customer Relations, 200 Taylor Street, 6th Floor, Fort Worth, TX 76102

12/99

SPECIFICATIONS

Cassette Deck

Tape System 2-track, monophonic cassette
Tape Speed 1 7/8 ips (4.8 cm/s)
Wow and Flutter (RMS) 0.6%
Frequency Response 250 Hz to 8 kHz (JEITA)
S/N Ratio 33 dB with VOLUME maximum
(-10 dB)

Erasing System DC
Recording System DC Bias
Tape Type Normal Bias (Type I)

Power Requirement

Batteries 2 AA Batteries
AC 120 Volts with optional AC Adapter
DC 12 Volts DC with optional DC Adapter
Typical Cassette Playing time
with AA Alkaline Batteries
About 12 Hours with Headphones
About 6 Hours with Speakers

General

Power Output 15 mW/Channel at 32 ohms
Dimensions (HWD) 4¹/₂ x 3⁵/₁₆ x 1³/₈ inches
(113.4 x 84 x 35.1 mm)
(excluding the projecting parts and controls)
Weight (without battery) 7.1 oz (200 g)

Specifications are typical; individual units might vary. Specifications are subject to change and improvement without notice.

Free Manuals Download Website

<http://myh66.com>

<http://usermanuals.us>

<http://www.somanuals.com>

<http://www.4manuals.cc>

<http://www.manual-lib.com>

<http://www.404manual.com>

<http://www.luxmanual.com>

<http://aubethermostatmanual.com>

Golf course search by state

<http://golfingnear.com>

Email search by domain

<http://emailbydomain.com>

Auto manuals search

<http://auto.somanuals.com>

TV manuals search

<http://tv.somanuals.com>