





SCP-107

AM/FM Digital Tune Stereo Cassette
Player



Owner's Manual
Please read before using this equipment.

WARNING: To reduce the risk of fire or shock hazard, do not expose this product to rain or moisture.

	CAUTION RISK OF ELECTRIC SHOCK. DO NOT OPEN.	
CAUTION: TO REDUCE THE RISK OF ELECTRIC SHOCK, DO NOT REMOVE COVER OR BACK. NO USER-SERVICEABLE PARTS INSIDE. REFER SERVICING TO QUALIFIED PERSONNEL.		



This symbol is intended to alert you to the presence of uninsulated dangerous voltage within the product's enclosure that might be of sufficient magnitude to constitute a risk of electric shock. Do not open the product's case.



This symbol is intended to inform you that important operating and maintenance instructions are included in the literature accompanying this product.

© 2000 Tandy Corporation. All Rights Reserved.
RadioShack and RadioShack.com are trademarks used by Tandy Corporation.

Contents

Features	4
The FCC Wants You to Know	6
Preparation	7
Connecting Power	7
Using Batteries	7
Using AC Power	10
Using Vehicle Battery Power	11
Using the Belt Clip	13
Connecting Headphones or Speakers	14
Listening Safely	14
Traffic Safety	15
Setting the Frequency Ranges and Steps	15
Using the Radio	18
Manual Tuning	20
Memory Tuning	20
Storing Stations Automatically (Only for AM and FM)	20
Storing Stations Manually	21
Selecting Stored Stations	22
Using Hold	23
Using the Tape Player	24
Loading a Cassette Tape	24
Playing a Tape	25
Using Reverse Mode	26
Using Fast-Forward and Rewind	27

Tape Tips 28
Restoring Tape Tension and
Sound Quality 28
Using the Sleep Timer 28

Playing the Games 30
Playing the Slot Machine Game 31
Scoring 32
Playing the Number Game 32
Scoring 33
Exiting the Game Mode 33

Care 34
Cleaning the Tape-Handling Parts .. 35
Resetting the Cassette Player 36

Specifications 37

▣ **Features**

Your RadioShack Digital AM/FM Stereo Cassette Player delivers excellent stereo sound and is portable, so you can listen to cassette tapes or AM/FM radio almost anywhere.

Important: To listen to your cassette player, you need a pair of headphones or amplified speakers (not supplied) with a 1/8-inch (3.5 mm) mini-plug. Your local RadioShack store sells a wide variety of headphones and speakers.



AM/FM Digital Tuning — gives you precise tuning and drift-free reception.



TV Band — lets you tune to VHF (channel 2–13) TV audio frequencies.

Two Auto Reverse Playback Options — you can play both sides of your tape once without turning the tape over or enjoy continuous play.

30-Station Memory — lets you store up to 30 of your favorite radio stations and TV audio frequencies for quick tuning.

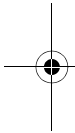

Game Function — lets you enjoy a challenging slot machine or number game anytime, anywhere.

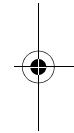

Extended Bass — for a powerful, heavy bass sound.

Sleep Timer — lets you set the cassette player to turn off after a specified time, so you can fall asleep as you listen to the radio or a cassette tape.

Belt Clip — lets you attach the cassette player to your belt for hands-free transport when you are on the go.

Three Power Options — give you the choice of using internal batteries (not sup-

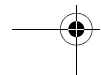
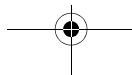



plied), standard AC power (with an optional AC adapter) or a vehicle battery (with an optional DC adapter) to power your cassette player.



Slim Design — lets you carry the cassette player almost anywhere.

THE FCC WANTS YOU TO KNOW

Note: Modifications or adjustments to this product which are not expressly approved by the manufacturer could void the user's authority to operate this product.

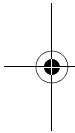

This device complies with Part 15 of the *FCC Rules*. Operation is subject to the following two conditions: (1) this device may not cause harmful interference.

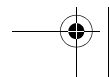
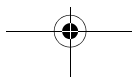
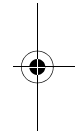

Preparation

CONNECTING POWER

You can power your cassette player from:

- internal batteries (not supplied)
- AC power (using an optional AC adapter)
- your vehicle's battery (using an optional DC adapter)

Note: Connecting an adapter automatically disconnects internal batteries.

Using Batteries

Your cassette player uses two AA batteries (not supplied) for power. For the best performance and longest life, we recommend RadioShack alkaline batteries.

You can also use rechargeable nickel-cadmium batteries to power your cassette player. Use a battery charger (available at your local RadioShack store) to recharge nickel-cadmium batteries.

Cautions:

- Use only fresh batteries of the required size and recommended type.
- Do not mix old and new batteries, different types of batteries (standard, alkaline, or rechargeable), or rechargeable batteries of different capacities.

Note: While you replace the batteries, the cassette player retains the preset station frequencies you stored for about 1 minute. To prevent the frequencies from being erased, replace the batteries within 1 minute.

To install batteries, follow these steps.

1. Press down and pull the battery compartment cover in the direction of the arrow marked on the cover. Lift open the cover.

Caution: The battery compartment cover is hinged. Do not try to remove it.

2. Place the batteries in the compartment as indicated by the polarity symbols (+ and -) and battery placement

drawings marked on the compartment cover.

3. Replace the cover.

The cassette player's battery indicator shows the amount of battery power remaining. The indicator consists of three sections. The more sections that appear, the higher the battery power.

If the indicator blinks or the cassette player stops operating properly, replace or recharge the batteries.

Warning: Dispose of old batteries promptly and properly. Do not burn or bury them.

Caution: If you do not plan to use the cassette player for a month or more, remove the batteries. Batteries can leak chemicals that destroy electronic parts.

Important: This cassette player can use nickel-cadmium rechargeable batteries. At the end of a nickel-cadmium battery's useful life, it must be recycled or disposed of properly. Contact your local, county, or state hazardous waste management authorities for information on re-



cycling or disposal programs in your area or call 1-800-822-8837. Some options that might be available are: municipal curbside collection, drop-off boxes at retailers such as your local RadioShack store, recycling collection centers, and mail-back programs.

Using AC Power

You can power the cassette player using a 3V, 250-mA regulated AC adapter and a size A Adaptaplug adapter (neither supplied). Both are available at your local RadioShack store.

Cautions:

- You must use a Class 2 power source that supplies regulated 3V DC and delivers at least 250 mA. Its center tip must be set to positive, and its plug must fit the cassette player's **DC 3V** jack. Using an adapter that does not meet these specifications could damage the cassette player or the adapter.
- Always connect the AC adapter to the cassette player before you connect it to AC power. When you finish, disconnect the adapter from AC power

before you disconnect it from the cassette player.

Follow these steps to connect the cassette player to AC power.

1. Set the adapter's voltage switch to 3V, if necessary.
2. Insert the Adaptaplug into the adapter's cord so it reads + TIP.
3. Insert the plug into the cassette player's **DC 3V** jack.
4. Plug the adapter into a standard AC outlet.

Using Vehicle Battery Power

You can power the cassette player from a vehicle's 12V power source (such as a cigarette-lighter socket) using a 3V, 250-mA regulated DC adapter and a size A Adaptaplug (neither supplied). Both are available at your local RadioShack store.

Cautions:

- You must use a power source that supplies regulated 3V DC and delivers at least 250 mA. Its center tip must be set to positive and its plug

must fit the cassette player's DC 3V jack. Using an adapter that does not meet these specifications could damage the cassette player or the adapter.

- Always plug the DC adapter to the cassette player before you connect it to the power source. When you finish, disconnect the adapter from the power source before you disconnect it from the cassette player.

Follow these steps to power the cassette player from your vehicle's battery.

1. Set the adapter's voltage switch to 3V, if necessary.
2. Insert the Adaptaplug into the adapter's cord, so it reads + TIP.
3. Insert the plug into the cassette player's DC 3V jack.
4. Plug the other end of the adapter into the vehicle's cigarette-lighter socket.

USING THE BELT CLIP

The supplied belt clip lets you keep your hands free while you listen to the cassette player.

Align the belt clip with the matching hole in the cassette player and turn the screw clockwise, then bend down the clip.

To remove the clip, turn the screw counterclockwise.

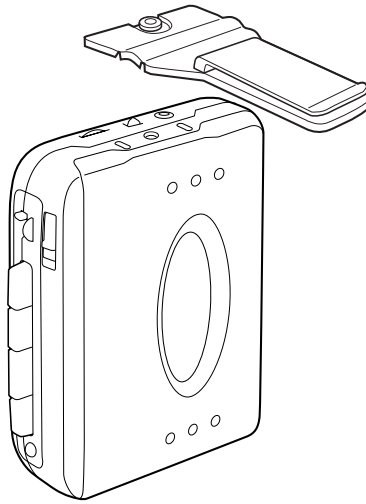

CONNECTING HEADPHONES OR SPEAKERS

To connect your headphones or amplified speaker system (not supplied) to the cassette player, insert the headphones' or amplified speaker system's $\frac{1}{8}$ -inch (3.5 mm) mini-plug into the cassette player's headphone jack.

Listening Safely

Follow these guidelines to protect your hearing when you use headphones.

- Set the volume to the lowest setting before you begin listening. After you begin listening, adjust the volume to a comfortable level.
- Do not listen at extremely high volume levels. Extended high-volume listening can lead to permanent hearing loss.
- Once you set the volume, do not increase it. Over time, your ears adapt to the volume level, so a volume level that does not cause discomfort might still damage your hearing.

Traffic Safety

Do not wear headphones while operating a motor vehicle or riding a bicycle. This can create a traffic hazard and could be illegal in some areas.

Even though some headphones let you hear some outside sounds when listening at normal volume levels, they still can present a traffic hazard.

SETTING THE FREQUENCY RANGES AND STEPS

The cassette player is preset to tune to frequencies in increments of 10 kHz (AM) and 0.2 MHz (FM) in the United States.

In Europe and some other parts of the world, AM and FM frequencies are broadcast in increments of 9 kHz (AM) and 0.05 MHz (FM). In Japan, AM and FM frequencies are broadcast in increments of 9 kHz (AM) and 0.1 MHz (FM). For proper tuning, set the frequency steps for AM and FM based on your location.

Note: Changing the frequency ranges and steps erases all stored stations.

Follow these steps to set the frequency ranges and steps.

1. Press **RADIO ON/OFF BAND** to turn on the radio.
2. Hold down both **AUTO PRESET** and **UP** for 3 seconds.

The tuner settings cycle in the following sequence:

US1 — US — JP — EU — US1

US1: North and South America with TV band
AM: 530 – 1,710 kHz (10 kHz step)
FM: 87.5 – 108.1 MHz (0.2 MHz step)
TV Audio: 2 – 13 channel
US: North and South America without TV band
AM: 530 – 1,710 kHz (10 kHz step)
FM1, FM2: 87.5 – 108.1 MHz (0.2 MHz step)
JP: Japan
AM: 531 – 1,629 kHz (9 kHz step)

FM1, FM2: 76 – 108 MHz (0.1 MHz step in 76 – 90 MHz, and 0.05 MHz step in 90 – 108 MHz)

EU: Europe and other areas

AM: 531 – 1,602 kHz (9 kHz step)

FM1, FM2: 87.5 – 108 MHz (0.05 MHz step)

Notes:

- To return to the factory preset frequency range and step directly, hold down the **TUNING UP** and **DOWN** buttons simultaneously for 3 seconds.
- In the US, JP and EU settings, the tuner band will change to AM, FM1 and FM2. FM1 and FM2 store stations in the same frequency range, but in different (separate) memory locations.

Using the Radio

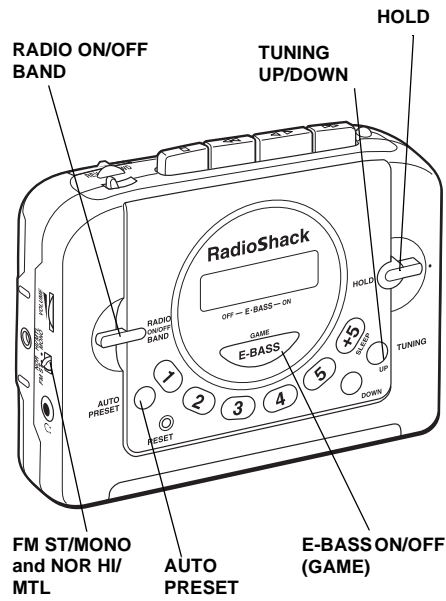

1. Repeatedly press **RADIO ON/OFF BAND** until the desired band appears (**AM**, **FM**, or **TV**).
2. To select stereo reception, set **FM ST/MONO** to **FM ST**. If the **FM** stereo signal is weak and distorted, set it to



MONO. The sound will be monaural, but the distortion will be reduced.



Notes:

- The AM antenna is built in. Position the cassette player for the best AM reception.
- For the best FM or TV reception, fully uncoil the headphones' or speakers' cord.

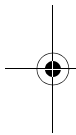

3. Use **TUNING UP** or **DOWN** to tune to the desired station using manual or memory tuning (see "Manual Tuning" on Page 20 or "Memory Tuning" on Page 20).

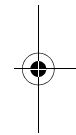

4. Adjust **VOLUME** to the desired listening level.

5. To emphasize the bass sounds, press **E-BASS** so that a bar appears above the **E-BASS-ON**. To turn it off, press **E-BASS** so that the bar appears above **E-BASS-OFF**.

6. To turn off the radio, repeatedly press **RADIO ON/OFF BAND** until the display is turned off.

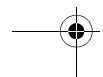
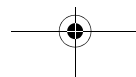

MANUAL TUNING

To manually tune the radio, repeatedly press **TUNING UP** or **DOWN** to reach the desired station.

For quicker tuning on AM and FM bands, hold down either **TUNING UP** or **DOWN** until the frequency on the display changes rapidly, then release the button. When a station is received, the frequency indicator stops automatically. However, it might not stop if the broadcast signal is weak.

MEMORY TUNING

You can store up to 10 stations each in the AM, FM, and TV band memories.

Storing Stations Automatically (Only for AM and FM)

1. Repeatedly press **RADIO ON/OFF BAND** until the desired band appears (**AM** or **FM**).
2. Hold **AUTO PRESET** for 1–2 seconds. Scanning starts with **PRESET** flashing.

Each time a station is received, scanning stops for 2 seconds, the tuned station is



stored, and scanning starts again. If you do not want the tuned station to be stored, press **AUTO PRESET** while tuning is paused.



Presetting is completed when 10 stations have been stored. Scanning stops on the 10th station.

Note: If the broadcasting signals are very weak, the stations cannot be preset automatically. Preset them manually.

Storing Stations Manually

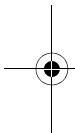

1. Repeatedly press **RADIO ON/OFF BAND** until the desired band appears (**AM**, **FM**, or **TV**).
2. Press **TUNING UP** or **DOWN** to reach the desired station.
3. Hold down one of the preset number buttons (**1–5**) for about 2 seconds. The selected preset number and **PRESET** appear and the cassette player stores the station.

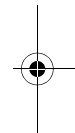

Note: To store stations in preset numbers 6–10, press **+5**, then hold down the appropriate number button for about 2 seconds. For example, to

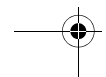
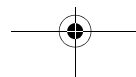

store a station in preset number 6, press **+5**, then hold down **1**.

Repeat Steps 1–3 to store more stations. To replace a station you stored, simply store a new station in that preset number.

Selecting Stored Stations

1. Repeatedly press **RADIO ON/OFF BAND** to select the desired band.
2. Press a preset number button (**1–5**) to select a stored station. To select preset numbers 6–10, press **+5** then the appropriate preset number button.

Notes:

- Do not hold down the preset number buttons for more than a second when you select a preset station. Otherwise, the station currently tuned in will be preset to that button.
- Since **+5** also activates the sleep timer, do not hold down **+5** for more than 2 seconds when you select a preset station. Otherwise, the cassette player will begin sleep timer set-up.



USING HOLD

HOLD locks the cassette player's radio function buttons and **E-BASS (GAME)** so you cannot accidentally change them. To lock the buttons, rotate **HOLD** down. **HOLD** flashes for several seconds, then appears steadily. To unlock the buttons, rotate **HOLD** up to the horizontal position.

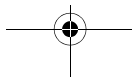
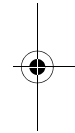
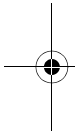

Using the Tape Player

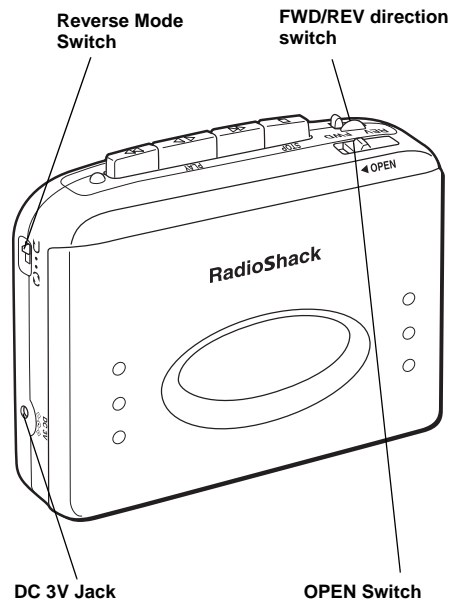

LOADING A CASSETTE TAPE

The cassette player uses normal bias, high-bias, and metal tapes.

Note: The cassette player comes with a block of foam to protect the cassette player's playback head during shipment. Remove the foam before loading a tape.

1. Take up any slack in the tape by turning the cassette's hub with a pencil. Do not touch the exposed tape.
2. Slide **OPEN** in the direction of the arrow and open the compartment door by pulling it toward you.
3. Insert a cassette into the door's tape guides with the cassette's open edge facing up and the desired side visible through the window.
4. Close the cassette compartment door.

PLAYING A TAPE

1. If the radio is on, turn it off by repeatedly pressing **RADIO ON/OFF BAND** until the display is turned off.
2. Slide **NOR HI/MTL** to **NOR** for Type I (normal bias) cassette tapes or to **HI/MTL** for Type II (high bias) and Type IV (metal) tapes.

3. Slide **FWD/REV** to **FWD** to play the side facing out, or to **REV** to play the reverse side.
4. Press **PLAY**. The battery indicator and **TAPE** appear and the tape begins to play.
5. Adjust **VOLUME** to a comfortable listening level.
6. To emphasize the bass sounds, press **E-BASS** until a bar appears above the **E-BASS-ON**. Press **E-BASS** until the bar appears above **E-BASS-OFF** to turn it off.
7. To stop the tape, press **STOP**.

USING REVERSE MODE

Set the reverse mode switch to choose the desired automatic reverse option:



One-Time Playback  — The cassette player plays one side of the tape, automatically reverses the tape's playback direction, plays the reverse side of the tape, then automatically stops.





Note: If you set **FWD/REV** to **REV**, the cassette player plays only the reverse side and stops at the end of that side. The cas-

sette player also stops when **FWD/REV** is changed from **REV** to **FWD**.

Continuous Playback  — The cassette player alternately plays each side of the tape until you press **STOP**.





USING FAST-FORWARD AND REWIND

While the tape is stopped, press  or  to rewind to fast-forward.

FWD/REV set to	To rewind, press	To fast-forward, press
FWD		
REV		

To stop the tape before it reaches the end, press  **STOP**.

Notes:

-  and  are not released at the end of the tape. Press  **STOP** to release them.
- To prevent tape damage, press  **STOP** before changing to radio mode.



TAPE TIPS

We do not recommend long-play cassette tapes such as C-120s because they are thin and can easily tangle.



Restoring Tape Tension and Sound Quality

After you play a cassette tape several times, the tape might become tightly wound on the reels. This can cause playback sound quality to deteriorate.

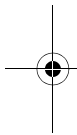

To restore the sound quality, fast-forward the tape from the beginning to the end of one side, then completely rewind it. Loosen the tape reels by gently tapping each side of the cassette's outer shell on a flat surface.

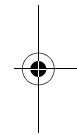

Caution: Be careful not to damage the cassette when tapping it. Do not touch the exposed tape or allow any sharp objects near the cassette.

USING THE SLEEP TIMER

You can set the cassette player to play up to 5 hours and 59 minutes, then automatically turn off. The cassette player must be on to set sleep timer.

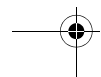
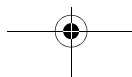



1. Hold down **SLEEP (+5)** until **SLEEP** flashes and a time appears.

- Note: If **SLEEP** disappears at any time during the sleep timer setting, you must start again from Step 1.

2. Within 3 seconds, repeatedly press **UP** to change the flashing digit. Press **DOWN** to change to the next digit. Repeat this step for each digit.

Or to use one of the preset sleep times, press one of the number buttons after holding down **SLEEP** until **SLEEP** flashes:

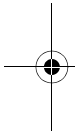

- Preset 1 – 15 minutes
- Preset 2 – 30 minutes
- Preset 3 – 45 minutes
- Preset 4 – 1 hour
- Preset 5 – 1 hour 30 minutes

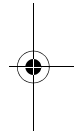

3. While **SLEEP** flashes, press **SLEEP** quickly to store your setting. **SLEEP** will then appear steadily.

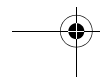
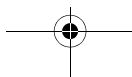

Notes:

- When the cassette player turns off after the sleep time runs out, **PLAY** is not released. Press **STOP** to prevent tape damage.
- When the cassette player turns off after the preset time, the sleep timer returns to 0:00.

To check the remaining time until the cassette player turns off, press **SLEEP** until the time appears. The remaining time appears for about 5 seconds, then the display returns to the last selected function.

To cancel the sleep timer, press **SLEEP** until the remaining time appears. While the time is shown, hold down **UP** and **DOWN** at the same time for more than 2 seconds to clear the remaining time. When 0:00 appears, press **SLEEP** while **SLEEP** flashes. **SLEEP** will disappear.

Playing the Games

Your cassette player has a slot machine game and a number game. You can play



either game in the standby, tuner, or tape mode.



Notes:

- You can switch from one game to another anytime during the game by pressing **GAME** once.
- While playing the game, all the buttons on the radio are disabled except those used to play the game, **RESET**, and **HOLD**.

PLAYING THE SLOT MACHINE GAME

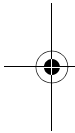

Game 1 is a slot machine game. You have 20 points when you start playing. To select the slot machine game, hold down **GAME** for about 3 seconds, until **000** and **1** appear.

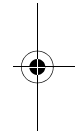

1. Press **+5** once to start the game. The numbers on the display change.
2. Repeatedly press **+5** to stop the numbers. The numbers stop one by one (from left to right).

If you do not press **+5** to stop the numbers, each digit automatically stops after a few seconds.

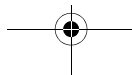



When all the digits have stopped, your score appears. To continue playing, repeat from Step 1.



Scoring

If **777** appears, you get 50 points and all the bar indicators flash.

If all the digits are the same but not **777** (such as **888**, **333**, and so on), you get 20 points and two bars flash.

If all the digits are different or only two digits are the same, you lose 1 point.

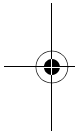

You win the game when your score reaches 999 points.

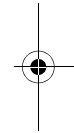

You lose the game when your score falls to 0 points.

PLAYING THE NUMBER GAME

The objective of Game 2 is to clear the number shown by pressing the same number, using the number buttons.

To select the number game, hold down **GAME** for about 3 seconds until **000** and

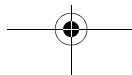



1 appear. Then press **GAME** again. **0000** and **2** appear.



1. Press **+5** once to start the game. Numbers from **1** to **5** appear, one at a time, at random.
2. As you see a number, press that button (**1–5**). If you press the correct button, two bar indicators flash. The more numbers you match, the sooner the next number disappears.

After one minute, the game ends automatically, all the bar indicators flash, and your score appears.

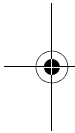

Scoring

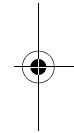

You get 1 point when you match a number. The maximum score is 50 points.

EXITING THE GAME MODE

The cassette player automatically exits the game mode if you stop playing for about 5 minutes. To exit the game mode sooner, hold down **GAME** for about 3 seconds. **bYE** flashes.

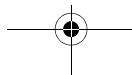

Care

To enjoy your cassette player for a long time:

- Keep the cassette player dry. If it gets wet, wipe it dry immediately.
- Use and store the cassette player only in normal temperature environments.
- Handle the cassette player gently and carefully. Do not drop it.
- Keep the cassette player away from dust and dirt.
- Wipe the cassette player with a damp cloth occasionally to keep it looking new.

Modifying or tampering with the cassette player's internal components can cause a malfunction and might invalidate its warranty and void your FCC authorization to operate it. If your cassette player is not performing as it should, take it to your local RadioShack store for assistance.

CLEANING THE TAPE-HANDLING PARTS

Dirt, dust, or particles of the tape's coating can accumulate on the tape head and other parts the tape touches. This can greatly reduce the performance of the cassette player. After every 20 hours of tape player operation, follow these steps to clean the tape-handling parts or use a RadioShack cassette deck cleaning kit.

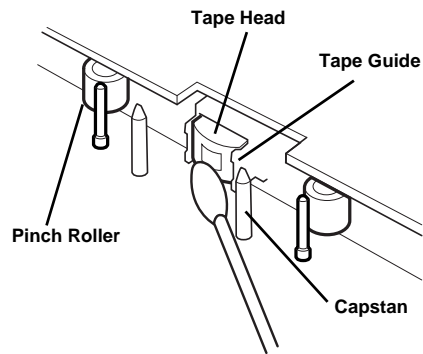

1. Remove the batteries and disconnect any other power source.
2. Open the cassette compartment door.
3. Press **PLAY** to expose the tape-handling parts.

4. Use a cotton swab dipped in denatured alcohol or tape head cleaning solution to clean the tape guides, playback head, pinch roller, and capstan.
5. When you finish cleaning, press **STOP** and close the cassette compartment door. Reconnect power.

RESETTING THE CASSETTE PLAYER

If the cassette player's display locks up or stops operating properly after you connect power, first replace the batteries with new ones. If the cassette player still does not operate properly, you must reset it. To reset the cassette player, use a pointed object such as a paper clip to press **RESET**.

Important: Resetting the cassette player clears all the settings you have stored. Reset the cassette player only when you are sure it is not working properly.

Specifications

RADIO

	FM	AM	TV
IF Rejection	65 dB	47 dB	75 dB
Image Rejection	22 dB	25 dB	20 dB
Signal-to-Noise (S/N) Ratio	50 dB	28 dB	35dB
Stereo Separation	20 dB at 1 kHz	—	—
Usable Sensitivity	16 dB μ V	55 dB μ V	20dB μ V

Frequency Range:

Reception Area US1 ... AM: 530–1,710 kHz
(10 kHz step)

FM: 87.5–108.1 MHz
(0.2 MHz step)

TV: channels 2–13

Reception Area US AM: 530–1,710 kHz
(10 kHz step)

FM: 87.5–108.1 MHz
(0.2 MHz step)

Reception Area JP AM: 531–1,629 kHz
(9 kHz step)
FM1, FM2: 76–108 MHz
(0.1 MHz step in 76–90 MHz)
(0.05 MHz step in 90–108 MHz)
Reception Area EU AM: 531–1,602 kHz
(9 kHz step)
Fm1, Fm2: 87.5–108 MHz
(0.05 MHz step)

TV Audio Reception

Channel	Frequency (MHz)
2	59.75
3	65.75
4	71.75
5	81.75
6	87.75
7	179.75
8	185.75
9	191.75
10	197.75
11	203.75
12	209.75
13	215.75

CASSETTE PLAYER

Cassette Mechanism Auto-stop
Wow and Flutter (WRMS) 0.3%

Signal-to-Noise Ratio 45 dB
Separation 30 dB
Frequency Response
(at -3 dB) 50-10000 Hz

GENERAL

Power Requirements .. DC 3V (2 AA Batteries)
DC Adapter (optional)
AC Adapter (optional)

Typical Radio Playing Time
with AA Alkaline Batteries About 39 Hours

Typical Cassette Playing Time
with AA Alkaline Batteries About 24 Hours

Headphones Output Impedance 32 Ohms

Dimensions (HWD) $4\frac{1}{2} \times 3\frac{3}{8} \times 1\frac{1}{4}$ Inches
(111.3 × 83 × 31.3 mm)
(excluding projecting parts and controls)

Weight (excluding batteries) 5 oz
(147 g)

Specifications are typical; individual units might vary. Specifications are subject to change and improvement without notice.

Limited Ninety-Day Warranty

This product is warranted by RadioShack against manufacturing defects in material and workmanship under normal use for ninety (90) days from the date of purchase from RadioShack company-owned stores and authorized RadioShack franchisees and dealers. EXCEPT AS PROVIDED HEREIN, RadioShack MAKES NO EXPRESS WARRANTIES AND ANY IMPLIED WARRANTIES, INCLUDING THOSE OF MERCHANTABILITY AND FITNESS FOR A PARTICULAR PURPOSE, ARE LIMITED IN DURATION TO THE DURATION OF THE WRITTEN LIMITED WARRANTIES CONTAINED HEREIN. EXCEPT AS PROVIDED HEREIN, RadioShack SHALL HAVE NO LIABILITY OR RESPONSIBILITY TO CUSTOMER OR ANY OTHER PERSON OR ENTITY WITH RESPECT TO ANY LIABILITY, LOSS OR DAMAGE CAUSED DIRECTLY OR INDIRECTLY BY USE OR PERFORMANCE OF THE PRODUCT OR ARISING OUT OF ANY BREACH OF THIS WARRANTY, INCLUDING, BUT NOT LIMITED TO, ANY DAMAGES RESULTING FROM INCONVENIENCE, LOSS OF TIME, DATA, PROPERTY, REVENUE, OR PROFIT OR ANY INDIRECT, SPECIAL, INCIDENTAL, OR CONSEQUENTIAL DAMAGES, EVEN IF RadioShack HAS BEEN ADVISED OF THE POSSIBILITY OF SUCH DAMAGES.

Some states do not allow limitations on how long an implied warranty lasts or the exclusion or limitation of incidental or consequential damages, so the above limitations or exclusions may not apply to you.

In the event of a product defect during the warranty period, take the product and the RadioShack sales receipt as proof of purchase date to any RadioShack store. RadioShack will, at its option, unless otherwise provided by law: (a) correct the defect by product repair without charge for parts and labor; (b) replace the product with one of the same or similar design; or (c) refund the purchase price. All replaced parts and products, and products on which a refund is made, become the property of RadioShack. New or reconditioned parts and products may be used in the performance of warranty service. Repaired or replaced parts and products are warranted for the remainder of the original warranty period. You will be charged for repair or replacement of the product made after the expiration of the warranty period. This warranty does not cover: (a) damage or failure caused by or attributable to acts of God, abuse, accident, misuse, improper or abnormal usage, failure to follow instructions, improper installation or maintenance, alteration, lightning or other incidence of excess voltage or current; (b) any repairs other than those provided by a RadioShack Authorized Service Facility; (c) consumables such as fuses or batteries; (d) cosmetic damage; (e) transportation, shipping or insurance costs; or (f) costs of product removal, installation, set-up service adjustment or reinstallation.

This warranty gives you specific legal rights, and you may also have other rights which vary from state to state.

RadioShack Customer Relations, 200 Taylor Street, 6th Floor, Fort Worth, TX 76102

We Service What We Sell 12/99

04A00
14-1250

8A-HRB-907-01
000207AKK-O-RS9
Printed in Indonesia

Free Manuals Download Website

<http://myh66.com>

<http://usermanuals.us>

<http://www.somanuals.com>

<http://www.4manuals.cc>

<http://www.manual-lib.com>

<http://www.404manual.com>

<http://www.luxmanual.com>

<http://aubethermostatmanual.com>

Golf course search by state

<http://golfingnear.com>

Email search by domain

<http://emailbydomain.com>

Auto manuals search

<http://auto.somanuals.com>

TV manuals search

<http://tv.somanuals.com>