



10-Inch B&W Single Channel Security Monitor

49-2514

OWNER'S MANUAL — Please read before using this equipment.

! IMPORTANT !

If an icon appears at the end of a paragraph, go to the side head box on that page with the corresponding icon for pertinent information.

-  — Signifies a **Warning**
-  — Signifies a **Caution**
-  — Signifies **Important** text

CONTENTS

Preparation	1
Connecting a Camera	2
Using a Video Surveillance Switchbox	2
Controls and Functions	3
Connections	4
Operation	6
Using the Alarm Mode	6
Using a VCR	6
VCR Recording	6
VCR Playback to the Monitor	7
Troubleshooting	7
Care	8
Service and Repair	8
Specifications	8

WARNING: To reduce the risk of fire or shock hazard, do not expose this product to rain or moisture.



CAUTION

RISK OF ELECTRIC SHOCK
DO NOT OPEN

CAUTION: TO REDUCE THE RISK OF ELECTRIC SHOCK, DO NOT REMOVE COVER OR BACK. NO USER-SERVICEABLE PARTS INSIDE. REFER SERVICING TO QUALIFIED PERSONNEL.



The lightning symbol is intended to alert you to the presence of uninsulated dangerous voltage within this product's enclosure that might be of sufficient magnitude to constitute a risk of electric shock. Do not open the product's case.



The exclamation symbol is intended to inform you that important operating and maintenance instructions are included in the literature accompanying this product.

Thank you for purchasing the RadioShack B&W 10-Inch 1-Channel Security Monitor. Your monitor is an important addition to your existing security system. It features flexible operation with many security oriented benefits.

10-Inch (Measured Diagonally) Monitor— provides a clear view for security detail.

800-Line Resolution — provides superior picture clarity.

Standard TV Controls — let you adjust sound and picture settings.

Built-in Alarm Mode and Melody Sound — lets you know when the camera's built-in passive infrared (PIR) sensor has detected movement.

VCR Connections — let you connect a VCR to record and play back all activity within the camera's view.

Two-Way Audio — lets you talk with someone near the camera.

PREPARATION

Before you install the monitor and any camera, carefully plan the location where you will route the connection cables. Keep the following in mind when planning the installation.

- This system is designed for indoor use only.
- Do not install any camera or monitor where it will be exposed to high humidity or rain.
- Select a location for the monitor that will not be blocked by objects or traffic. Make sure the selected location is not in direct sunlight with a direct light source that might make observing the monitor difficult.
- Do not route any of the connecting cables close to the power or telephone lines, transformers, or other electrical equipment that could interfere with your security system or with any nearby system or device.



RadioShack[®]

www.radioshack.comSM

© 2002 RadioShack Corporation.

All Rights Reserved.

RadioShack and RadioShack.com are trademarks used by RadioShack Corporation.

 **NOTES** 

- You cannot use the alarm function or talk with the person near the camera with this connection.
- To view any signal connected to the **V-IN/A-IN** jacks, you must press **VCR**, so the indicator lights. Press **VCR**, so the indicator goes out to switch back to the other camera view.

 **NOTE** 

Since the switchbox is connected to the **V-IN/A-IN** jacks, you must press **VCR**, so the indicator lights to view /listen to signals coming through the switchbox.

CONNECTING A CAMERA

Follow these steps to connect either the RadioShack Cat. No. 49-2515 or 49-2516 camera. Use the cable that comes with the camera to make the connections.

1. Connect the mini-DIN plug at one end of the 59-foot cable supplied with the camera to the **CAMERA IN** mini-DIN jack on the rear of the monitor.
2. Connect the other end of the cable to the mini-DIN jack at the end of the cable from the camera.
3. Plug the monitor's AC power cord into a standard AC outlet.

You can also connect an additional camera to the **V-IN/A-IN** jacks, as long as you do not use these jacks to connect a VCR.

1. Using the camera's supplied 6-inch adapter cable, connect the camera's Audio Out plug to the monitor's **A-IN** jack and the camera's Video Out plug to the monitor's **V-IN** jack.
2. Connect the camera's supplied AC adapter to the 6-inch adapter cable's **DC IN** barrel jack.
3. Connect the DIN plug on the other end of the cable to the camera's 59-foot cable and connect the long cable to the cable on the camera.

You can also use these jacks to connect other cameras which have video/audio output jacks.

USING A VIDEO SURVEILLANCE SWITCHBOX

You can also connect the monitor to the RadioShack Video Surveillance Switchbox (Cat. No. 49-2517). This switchbox has two camera inputs to automatically switch the view between two areas. You cannot use the talk and alarm functions of the monitor if connected to the switchbox. The switchbox has its own intercom and alarm controls, which you must use in this configuration.

CONTROLS AND FUNCTIONS

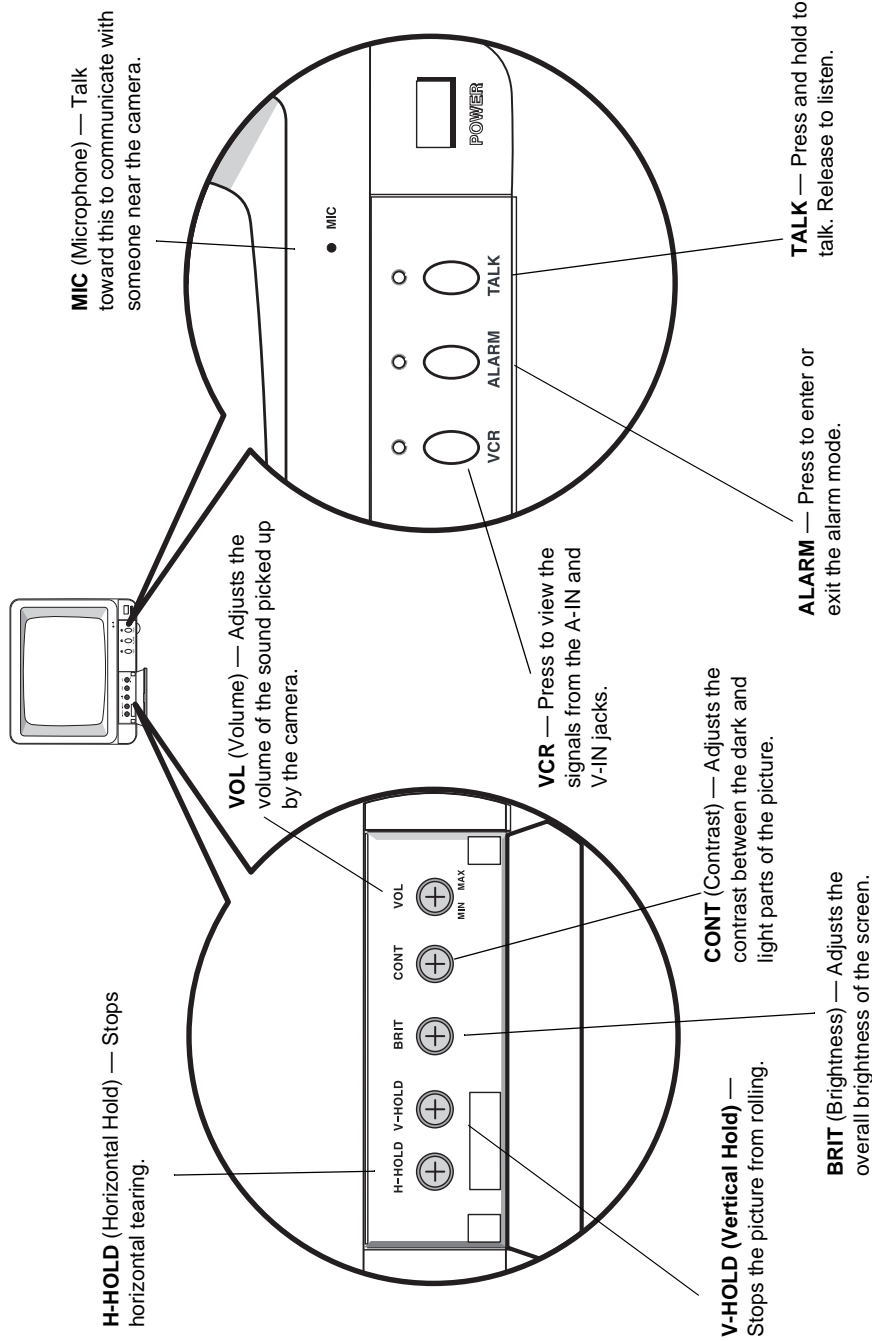

CONNECTIONS

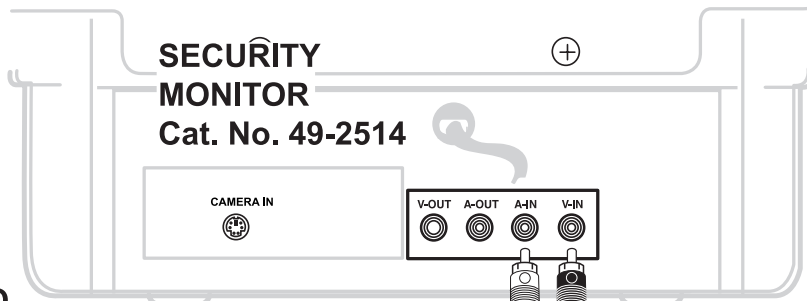
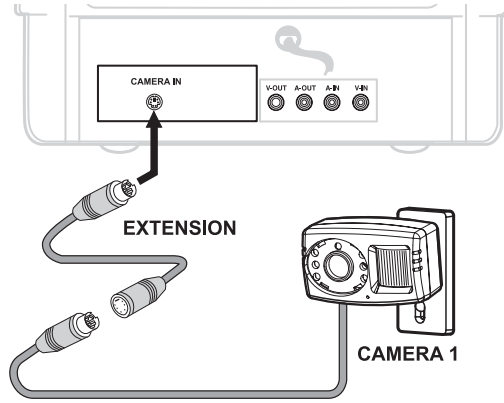

Connections

VIDEO SURVEILLANCE SWITCHBOX
Cat. No. 49-2517

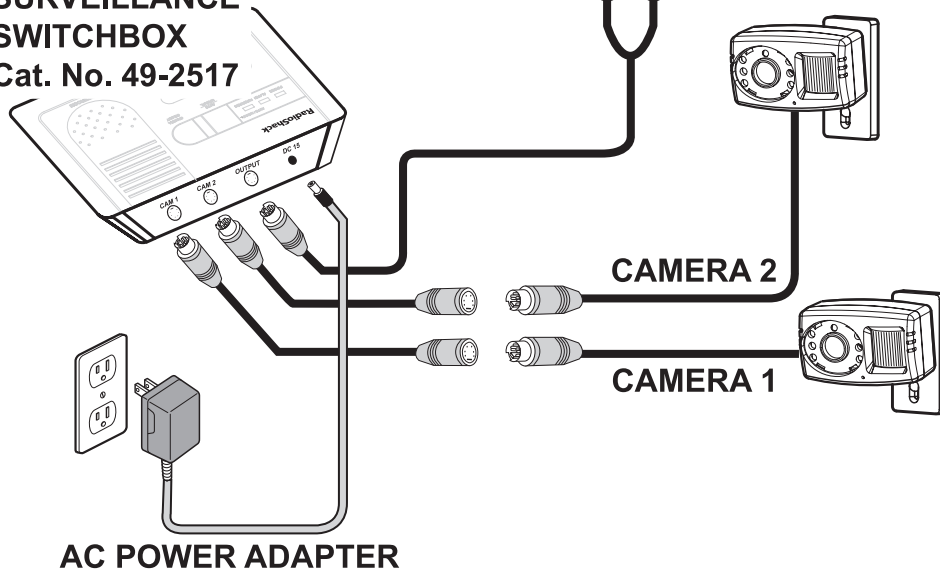

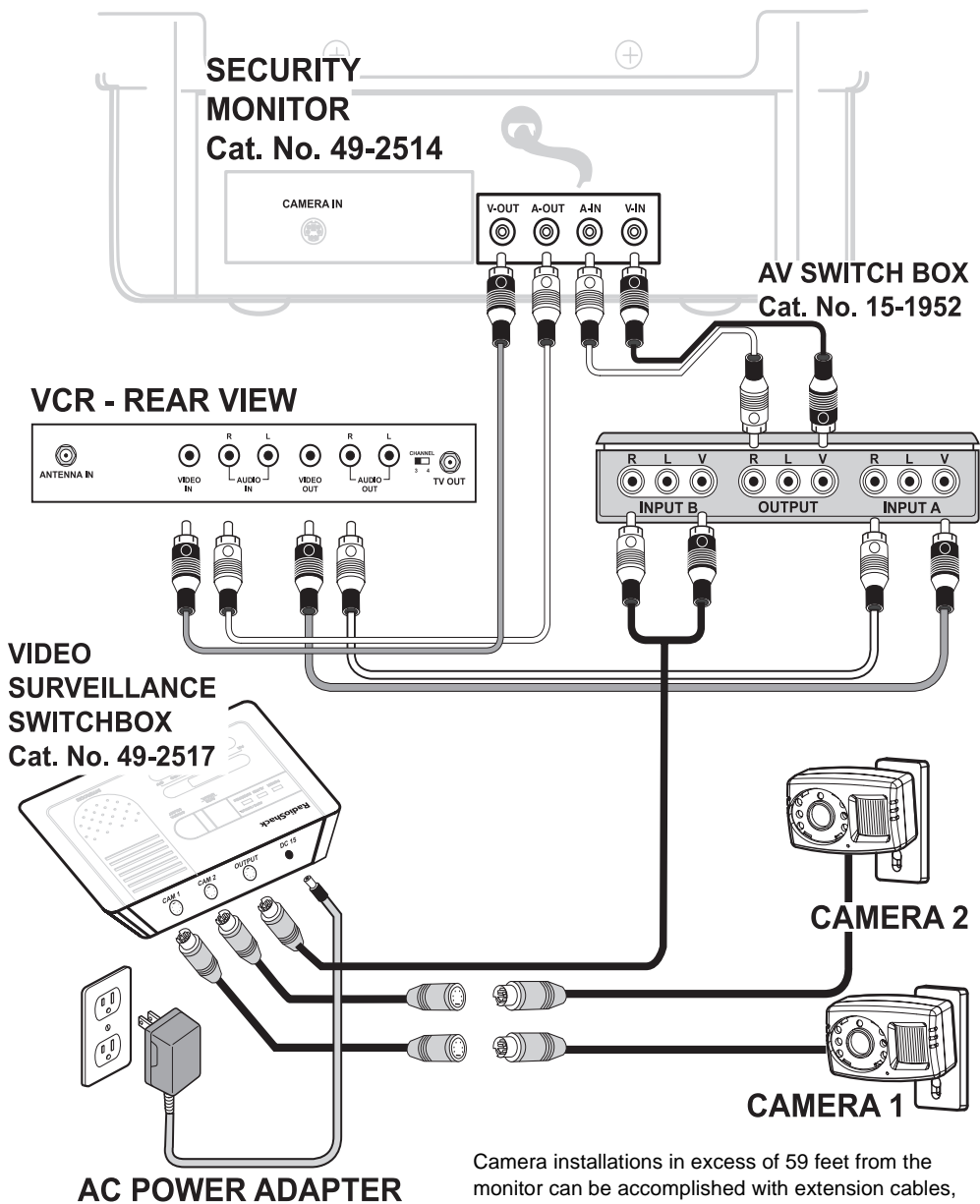

Connections

Camera installations in excess of 59 feet from the monitor can be accomplished with extension cables, such as catalog numbers 980-0646 (131-foot cable) or 980-0647 (196-foot cable). Both of these extension cables require an extension adapter (catalog number 980-0671.)

 **NOTES** 

If you connected a second camera to the **V-IN/A-IN** jacks, press **VCR** so the indicator lights to view the signal from the second camera.

 **NOTES** 

- The VCR records sound from the camera, but does not record your voice when you talk to a person near the camera or the alarm chime.
- With the 49-2516 camera, you can record the picture in color (although the monitor screen shows only black and white). To view the recording in color, you must connect a color TV/monitor to your VCR.

 **NOTES** 

- If your VCR has no provision for recording a separate external source, special accessories are available at your local store.
- In addition to standard VCRs, we recommend the use of time-lapse recorders, such as catalog number 980-0834.

OPERATION

Press **POWER** on the monitor. If the VCR indicator lights, press **VCR** so the indicator turns off to view the signals from camera.

To talk to someone near the camera, hold down **TALK** so the TALK indicator lights. Speak into **MIC** beneath the screen. Release **TALK** to listen.

USING THE ALARM MODE

Press **ALARM** so the ALARM indicator lights to enter the alarm mode. When the camera built-in PIR sensor detects any motion around the camera, the monitor sounds a chime. To exit the alarm mode, press **ALARM** again so the indicator turns off.

USING A VCR

You can connect a VCR equipped with separate audio and video input jacks to the monitor, then play back the recording on the monitor or a standard TV equipped with AV input jacks.

To record the sound and picture from your camera, connect the monitor's **V-OUT** and **A-OUT** jacks to the audio and video input jacks of your VCR using video-quality shielded cables (not supplied).

If you plan to play the recorded tape through the monitor, connect the monitor's **V-IN** and **A-IN** jacks to the VCR's audio and video output jacks using video-quality shielded cable (not supplied).

If you plan to use two cameras with the monitor and VCR, we recommend adding an A/V switchbox to avoid the need to unplug and reconnect cables during tape playback (see "Connections" on Page 4).

VCR RECORDING

1. Turn on the system and the VCR.
2. Load a blank video cassette, or one you want to record over, into the VCR.
3. Most VCRs either have a switch or are programmed to let you switch between a TV and another input source connected to the audio/video jacks. Use the available method to select the source connected to the audio/video input jacks.

4. Select the desired recording speed and other settings on your VCR.
5. Begin recording.

VCR PLAYBACK TO THE MONITOR

To view a recorded tape through the monitor, follow these steps.

1. Turn on the monitor and the VCR.
2. Press **VCR** on the monitor's front panel. The VCR indicator lights.
3. Begin playback on the VCR.

TROUBLESHOOTING

If your monitor is not working as it should, these suggestions might help you eliminate the problem. If the monitor still does not operate properly, take it to your local store for assistance.

No picture appears.

- Be sure the monitor's power is on.
- Check the connections between the camera and the monitor. Be sure audio and video cable connections are secure.
- Adjust **CONT**.

Image is not clear.

- Adjust **CONT**.
- Adjust **BRIT**.
- Adjust **V-HOLD** or **H-HOLD**.
- Be sure the selected camera is not pointed directly at a light source.

Cannot record to a VCR.

- Check the cable connections. Be sure audio and video cables are not reversed.
- Be sure the VCR is set to audio/video input and is set to record.
- Check the connections between the camera and the monitor.

Limited Ninety-Day Warranty

This product is warranted by RadioShack against manufacturing defects in material and workmanship under normal use for ninety (90) days from the date of purchase from RadioShack company-owned stores and authorized RadioShack franchisees and dealers. EXCEPT AS PROVIDED HEREIN, RadioShack MAKES NO EXPRESS WARRANTIES AND ANY IMPLIED WARRANTIES, INCLUDING THOSE OF MERCHANTABILITY AND FITNESS FOR A PARTICULAR PURPOSE, ARE LIMITED IN DURATION TO THE DURATION OF THE WRITTEN LIMITED WARRANTIES CONTAINED HEREIN. EXCEPT AS PROVIDED HEREIN, RadioShack SHALL HAVE NO LIABILITY OR RESPONSIBILITY TO CUSTOMER OR ANY OTHER PERSON OR ENTITY WITH RESPECT TO ANY LIABILITY, LOSS OR DAMAGE CAUSED DIRECTLY OR INDIRECTLY BY USE OR PERFORMANCE OF THE PRODUCT OR ARISING OUT OF ANY BREACH OF THIS WARRANTY, INCLUDING, BUT NOT LIMITED TO, ANY DAMAGES RESULTING FROM INCONVENIENCE, LOSS OF TIME, DATA, PROPERTY, REVENUE, OR PROFIT OR ANY INDIRECT, SPECIAL, INCIDENTAL, OR CONSEQUENTIAL DAMAGES, EVEN IF RadioShack HAS BEEN ADVISED OF THE POSSIBILITY OF SUCH DAMAGES.

Some states do not allow limitations on how long an implied warranty lasts or the exclusion or limitation of incidental or consequential damages, so the above limitations or exclusions may not apply to you.

In the event of a product defect during the warranty period, take the product and the RadioShack sales receipt as proof of purchase date to any RadioShack store. RadioShack will, at its option, unless otherwise provided by law: (a) correct the defect by product repair without charge for parts and labor; (b) replace the product with one of the same or similar design; or (c) refund the purchase price. All replaced parts and products, and products on which a refund is made, become the property of RadioShack. New or reconditioned parts and products may be used in the performance of warranty service. Repaired or replaced parts and products are warranted for the remainder of the original warranty period. You will be charged for repair or replacement of the product made after the expiration of the warranty period.

This warranty does not cover: (a) damage or failure caused by or attributable to acts of God, abuse, accident, misuse, improper or abnormal usage, failure to follow instructions, improper installation or maintenance, alteration, lightning or other incidence of excess voltage or current; (b) any repairs other than those provided by a RadioShack Authorized Service Facility; (c) consumables such as fuses or batteries; (d) cosmetic damage; (e) transportation, shipping or insurance costs; or (f) costs of product removal, installation, set-up service adjustment or reinstallation.

This warranty gives you specific legal rights, and you may also have other rights which vary from state to state.

RadioShack Customer Relations, 200 Taylor Street, 6th Floor, Fort Worth, TX 76102

12/99

Cannot play back using the monitor.

- Check the cable connections. Be sure the audio and video cables are not reversed.
- Be sure the VCR is set to play.

CARE

Keep the monitor dry; if it gets wet, wipe it dry immediately. Use and store the monitor only in normal temperature environments. Handle the monitor carefully; do not drop it. Keep the monitor away from dust and dirt, and wipe it with a damp cloth occasionally to keep it looking new.

SERVICE AND REPAIR

If your monitor is not performing as it should, take it to your local RadioShack store for assistance. Modifying or tampering with the monitor's internal components can cause a malfunction and might invalidate its warranty.

SPECIFICATIONS

Picture Tube.....	B&W 10-Inch tube with 90 deflection
Power Source	AC 120V, 60Hz
Power Consumption.....	Max. 30W
Resolution	More than 800 lines at center
TV System	EIA standard
Video-in.....	1V p-p composite at 75 ohm 1 DIN from camera, 1 phono from VCR
Audio-in.....	1 DIN from camera, 1 phono from VCR
Video-out.....	1 phono to VCR
Audio-out.....	1 DIN to camera, 1 phono to VCR
Alarm-in.....	1 DIN from camera
Operating Humidity	Under 90% RH
Dimensions (HWD)	9 x 10 1/8 x 9 7/8 inches (230 x 257 x 250 mm)
Weight.....	9.9 lbs (4.5 kg)

Specifications are typical; individual units might vary. Specifications are subject to change and improvement without any notice.

Free Manuals Download Website

<http://myh66.com>

<http://usermanuals.us>

<http://www.somanuals.com>

<http://www.4manuals.cc>

<http://www.manual-lib.com>

<http://www.404manual.com>

<http://www.luxmanual.com>

<http://aubethermostatmanual.com>

Golf course search by state

<http://golfingnear.com>

Email search by domain

<http://emailbydomain.com>

Auto manuals search

<http://auto.somanuals.com>

TV manuals search

<http://tv.somanuals.com>