

# Ford F-150

60-4335

OWNER'S MANUAL — Please read before using this equipment.

## CONTENTS

Attaching the Antennas .....	1
On the Truck .....	1
On the Transmitter .....	2
Installing Batteries .....	2
In the Transmitter .....	2
In the Truck .....	2
Recycling Ni-Cd Batteries .....	3
Driving the Truck .....	4
Adjusting the Trim Controls ..	5
Helpful Hints .....	5
Racing Two or More Vehicles Together .....	6
The FCC Wants You To Know ....	6
Care .....	7
Service and Repair .....	7

Thank you for purchasing a RadioShack Ford F-150. Your truck can make you a winner! With its proportional speed and precise steering, you can drive the truck almost anywhere. Built to  $\frac{1}{8}$  scale, it can reach speeds of up to 1,200 feet per minute and climb hills up to 45°.

**Four Frequencies** — let you race against other radio-controlled vehicles. Check your truck's box to see which frequency it uses.

**Supplied Box Wrench** — lets you easily remove and replace the truck's wheels. Be careful not to discard the wrench when you unpack the truck.

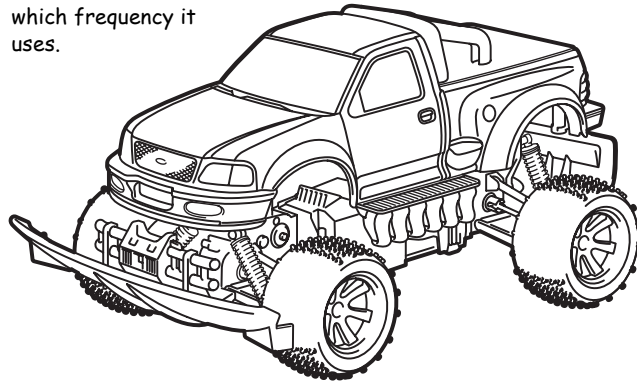

**Double Wishbone Front and Rear Suspension and High-Performance Tires** — give it good traction on almost any terrain. The front- and rear-wheel differential gears let you take smooth, sharp corners.

## ATTACHING THE ANTENNAS

### ON THE TRUCK

The antenna tube holds up the truck's antenna wire for the best reception and range. Route the antenna wire's loose end through the tube. Then insert the tube securely into the truck's antenna tube holder.

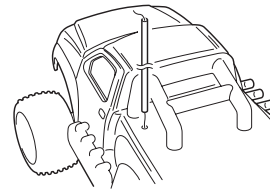

### IMPORTANT!

If an icon appears at the end of a paragraph, go to the box on that page with the corresponding icon for pertinent information.

- ⚠ — Warning
- ! — Important
- ⚡ — Caution
- 💡 — Hint
- 📝 — Note



**RadioShack**®

www.radioshack.com<sup>SM</sup>

© 2002 RadioShack Corporation.

All Rights Reserved.

RadioShack and RadioShack.com are trademarks used by RadioShack Corporation.

**⚠ WARNING ⚠**

Dispose of old batteries and the battery pack promptly and properly; do not burn or bury them.

**⚡ CAUTION ⚡**

- Use only fresh battery of the required size and recommended type.
- If you will not be using the truck for a week or more, remove the battery from the transmitter and the battery pack from the truck. Batteries can leak chemicals that can damage electronic parts.
- Never leave dead or weak batteries in the truck or transmitter.

## ON THE TRANSMITTER

Thread the antenna into the transmitter's antenna connector. Make sure the connection is tight.

## INSTALLING BATTERIES

You need one 9-volt battery for the transmitter, at least one 7.2-volt battery pack for the truck, and a battery pack charger (all available at your local RadioShack store or online at [www.radioshack.com](http://www.radioshack.com)). ⚠ ⚡

### IN THE TRANSMITTER

The transmitter requires one 9-volt battery. For the best performance and longest life, we recommend a RadioShack alkaline battery.

1. Slide the transmitter's **ON/OFF** switch to **OFF**.
2. Press down the battery compartment cover and slide it off in the direction of the arrow.
3. Put the battery in the compartment as indicated by the polarity symbols (+ and -) marked inside.
4. Replace the battery compartment cover.

If the transmitter's range decreases, replace the battery.

### IN THE TRUCK

Your truck requires a rechargeable 7.2-volt battery pack. Before you use the battery pack, you must charge it using a special battery charger. Follow the charger's instructions to charge the battery pack.

1. Slide the truck's **ON/OFF** switch under the truck to **OFF**.
2. Lift the battery compartment's tab and slide the cover in the direction of the arrow marked on it. Then lift off the cover.

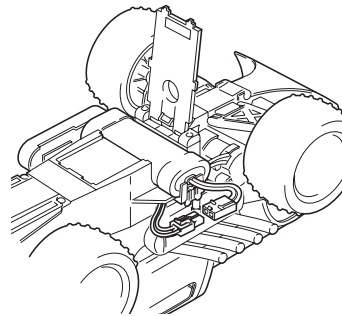

3. Place the battery pack between the compartment door and the body of the truck. The battery pack's connector must be on the same side as the truck's matching connector.
4. Attach the battery pack's connector to the truck's matching connector. Do not force them. They only fit together one way. ⚠️
5. Close the cover.

If the truck loses power or does not respond to the transmitter, recharge the battery pack.

To remove the battery pack, unplug the connectors and open the cover as described in Step 2. Then slide the pack toward the pack's connector and lift the other side of the battery pack. ⚠️ ⚡

To obtain the longest life from your truck, let the truck cool for at least 10 minutes before installing a new or newly charged battery pack.

### RECYCLING NI-Cd BATTERIES

The EPA certified RBRC® Battery Recycling Seal on the nickel-cadmium (Ni-Cd) battery indicates RadioShack is voluntarily participating in an industry program to collect and recycle these batteries at the end of their useful life, when taken out of service in the United States or Canada. The RBRC program provides a convenient alternative to placing used Ni-Cd batteries into the trash or the municipal waste stream, which may be illegal in your area. Please call 1-800-THE-SHACK (1-800-843-7422) for information on Ni-Cd battery recycling and disposal bans/restrictions in your area. RadioShack's involvement in this program is part of the company's commitment to preserving our environment and conserving our natural resources.



**⚠️ WARNING ⚠️**  
Do not touch the motor immediately after using the truck, as it might become hot during use.

**⚡ CAUTION ⚡**

- Be sure the connector and wires do not touch any of the truck's moving parts.
- Use only the recommended battery pack and charger.
- Do not charge or recharge the battery pack while it is in the truck.
- After you charge or recharge the battery pack, disconnect it from the charger. Overcharging the battery pack could damage it.
- When you disconnect the battery pack from the charger, do not pull on the connector's wires. You might damage the battery pack.
- Do not play with your truck in the street.

**📌 NOTE 📌**

- Occasionally, let the battery pack fully discharge before recharging it. Otherwise, the battery pack loses its ability to fully charge.
- To run your truck for extended periods of time, we suggest you purchase an extra battery pack. You can charge one while you use the other.

**CAUTION**

If the truck gets stuck under an object, immediately release the transmitter's control levers and retrieve the truck. When you finish playing with the truck, slide the **ON/OFF** switches on the truck and the transmitter to **OFF**.

**NOTE**

This truck can reach much higher speeds than most radio-controlled vehicles. Avoid high-impact collisions with people and objects.

## DRIVING THE TRUCK

1. Extend the transmitter's antenna to its full length.
2. Slide the **ON/OFF** switches on the transmitter and the truck to **ON**.

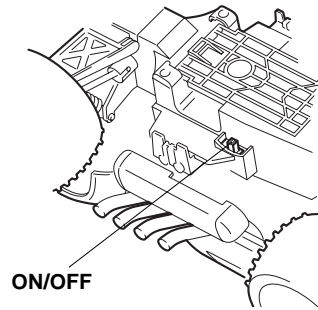
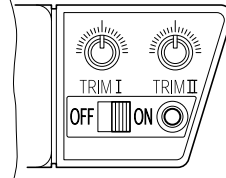

3. Hold the transmitter in your left hand. With your left index finger in the trigger mechanism and the controls facing you, use the transmitter's trigger and wheel to drive and steer the truck. **CAUTION**

### Steering Control Wheel

- Turn left to move left.
- Turn right to move right.
- Release to go straight. **CAUTION**

### Speed Control Trigger

- Pull the trigger left to move forward. Increasing the pull increases the truck's speed.
- Push the trigger right to move backward.
- Release to stop.

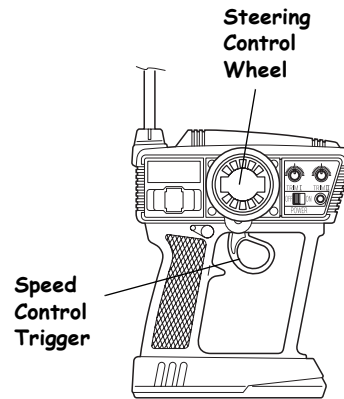

## ADJUSTING THE TRIM CONTROLS

The neutral trim control (TRIM II above the ON/OFF switch) lets you fine-tune the speed control so the truck stops completely when you release the speed control.

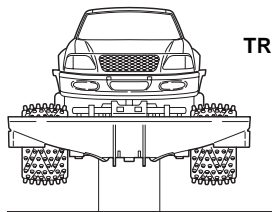
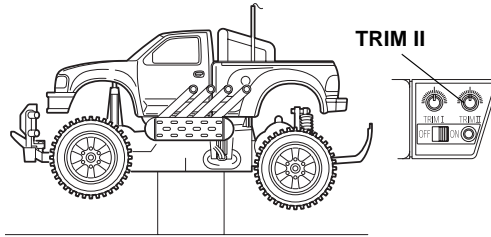

The steering trim control (TRIM I above the ON/OFF switch) lets you fine-tune the steering so the truck drives in a straight line when you set the steering control to its center position. ✓

steering control to its center position. ✓

1. Place the truck on a block or turn it over so the tires do not touch the ground. ✓
2. Slide the ON/OFF switches on the transmitter and truck to ON. vehicles. If the tires move, turn TRIM II until the tires stop. ✖
3. If the front tires angle left or right, turn TRIM I until they point directly forward.
4. When you finish the adjustment, slide the ON/OFF switches on the transmitter and the truck to OFF.

## HELPFUL HINTS

These hints can help you get the most enjoyment from your truck.

- If someone uses a CB nearby, it might interfere with control of the truck. If this happens, move the truck and transmitter away from the CB.
- If the truck moves slowly and you have installed a fully charged battery pack, check the wheel mechanisms for lint, thread, hair, truck or dust.

### NOTE

- Do not touch the tires while adjusting the trim controls.
- You might have to further fine-tune TRIM I after using the truck for a while.

### CAUTION

Never set TRIM II to make the truck continually move.

## RACING TWO OR MORE VEHICLES TOGETHER

The truck and other radio-controlled vehicles use specific frequencies to operate. Vehicles with different control frequencies can race together without interference. Vehicles with the same frequency cannot.

The following chart shows the available control frequencies for your truck, based on its ribbon color. If you buy more than one truck and you plan to race them, check the stickers on the boxes to be sure they are different band numbers/colors for different frequencies.

Band	Frequency	Ribbon Color
1	26.995MHz	Brown
2	27.045MHz	Red
3	27.095MHz	Orange
5	27.195MHz	Green

## THE FCC WANTS YOU TO KNOW

Your truck or transmitter might cause TV or radio interference even when it is operating properly. To determine whether your truck or transmitter is causing the interference, turn off your truck and the transmitter. If the interference goes away, your truck or transmitter is causing it. Try to eliminate the interference by:

- moving your truck and transmitter away from the TV or radio.
- Contacting your local RadioShack store for help.

If you cannot eliminate the interference, the FCC requires that you stop using your truck.

## CARE

Keep the truck dry; if it gets wet, wipe it dry immediately. Use and store the truck only in normal temperature environments. Handle the truck carefully; do not drop it. Keep the truck away from dust and dirt, and wipe it with a damp cloth occasionally to keep it looking new.

## SERVICE AND REPAIR

If your truck is not performing as it should, take it to your local RadioShack store for assistance. Modifying or tampering with the truck's internal components can cause a malfunction and might invalidate its warranty and void your FCC authorization to operate it.

### Limited Ninety-Day Warranty

This product is warranted by RadioShack against manufacturing defects in material and workmanship under normal use for ninety (90) days from the date of purchase from RadioShack company-owned stores and authorized RadioShack franchisees and dealers. EXCEPT AS PROVIDED HEREIN, RadioShack MAKES NO EXPRESS WARRANTIES AND ANY IMPLIED WARRANTIES, INCLUDING THOSE OF MERCHANTABILITY AND FITNESS FOR A PARTICULAR PURPOSE, ARE LIMITED IN DURATION TO THE DURATION OF THE WRITTEN LIMITED WARRANTIES CONTAINED HEREIN. EXCEPT AS PROVIDED HEREIN, RadioShack SHALL HAVE NO LIABILITY OR RESPONSIBILITY TO CUSTOMER OR ANY OTHER PERSON OR ENTITY WITH RESPECT TO ANY LIABILITY, LOSS OR DAMAGE CAUSED DIRECTLY OR INDIRECTLY BY USE OR PERFORMANCE OF THE PRODUCT OR ARISING OUT OF ANY BREACH OF THIS WARRANTY, INCLUDING, BUT NOT LIMITED TO, ANY DAMAGES RESULTING FROM INCONVENIENCE, LOSS OF TIME, DATA, PROPERTY, REVENUE, OR PROFIT OR ANY INDIRECT, SPECIAL, INCIDENTAL, OR CONSEQUENTIAL DAMAGES, EVEN IF RadioShack HAS BEEN ADVISED OF THE POSSIBILITY OF SUCH DAMAGES.

Some states do not allow limitations on how long an implied warranty lasts or the exclusion or limitation of incidental or consequential damages, so the above limitations or exclusions may not apply to you.

In the event of a product defect during the warranty period, take the product and the RadioShack sales receipt as proof of purchase date to any RadioShack store. RadioShack will, at its option, unless otherwise provided by law: (a) correct the defect by product repair without charge for parts and labor; (b) replace the product with one of the same or similar design; or (c) refund the purchase price. All replaced parts and products, and products on which a refund is made, become the property of RadioShack. New or reconditioned parts and products may be used in the performance of warranty service. Repaired or replaced parts and products are warranted for the remainder of the original warranty period. You will be charged for repair or replacement of the product made after the expiration of the warranty period.

This warranty does not cover: (a) damage or failure caused by or attributable to acts of God, abuse, accident, misuse, improper or abnormal usage, failure to follow instructions, improper installation or maintenance, alteration, lightning or other incidence of excess voltage or current; (b) any repairs other than those provided by a RadioShack Authorized Service Facility; (c) consumables such as fuses or batteries; (d) cosmetic damage; (e) transportation, shipping or insurance costs; or (f) costs of product removal, installation, set-up service adjustment or reinstallation.

This warranty gives you specific legal rights, and you may also have other rights which vary from state to state.

RadioShack Customer Relations, 200 Taylor Street, 6th Floor, Fort Worth, TX 76102

12/99



## Free Manuals Download Website

<http://myh66.com>

<http://usermanuals.us>

<http://www.somanuals.com>

<http://www.4manuals.cc>

<http://www.manual-lib.com>

<http://www.404manual.com>

<http://www.luxmanual.com>

<http://aubethermostatmanual.com>

Golf course search by state

<http://golfingnear.com>

Email search by domain

<http://emailbydomain.com>

Auto manuals search

<http://auto.somanuals.com>

TV manuals search

<http://tv.somanuals.com>