

RadioShack[®]

www.radioshack.comSM

AM/FM/CD/Cassette Portable

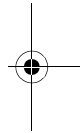

Owner's Manual
Please read before using this equipment.

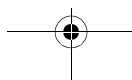

□ Features

Your RadioShack AM/FM/CD/Cassette Portable is an all-in-one music system with a AM/FM stereo radio, a cassette recorder, and a top-loading CD player. It is small and portable so you can take it anywhere, indoors or out. Anywhere you go, at work or play, you can listen to the radio, prerecorded cassette tapes, or compact discs.

Dual 3¹/₂-inch Speakers — provide quality stereo sound.

Programmed Play — lets you program the system to play up to 16 tracks in any order you choose, and even program the same track to play more than once.

Tone Control — lets you set the balance between high and low tones.

Headphone Jack — lets you connect a pair of headphones or stereo earphones for private listening.

Automatic Stop — protects the tape and tape-handling parts by automatically stopping the tape when it reaches the end.

Dual-Source Recording — lets you record from the CD player or radio.

Automatic Level Control — automatically adjusts the recording level.

Automatic Search Music System — lets you quickly locate and play any track on a CD.

Repeat Play — lets you continuously repeat a single track, all tracks on a CD, or an entire programmed sequence of tracks.

Two Power Options — you can use standard AC power (with the supplied AC power

cord) or internal batteries (not supplied) to power the player.

Important: Most material on compact discs and prerecorded tapes is copyrighted. Unauthorized duplication of copyrighted material is a violation of the copyright laws of most countries and such duplication may result in fines and/or imprisonment. Note, however, that in the United States, it is not a violation of U.S. copyright laws for a consumer to use musical recordings for noncommercial (personal) use.

CDs that can be played on this CD player have this mark on them:



The CD player's advanced technology makes it simple to operate. But, be sure you read this Owner's Manual completely so you can take advantage of all its advanced features.



This CD player is made and tested to meet exacting safety standards. It meets FCC requirements and complies with safety performance standards of the U.S. Department of Health and Human Services.

Warnings:

- This CD player employs a laser light beam. Only a qualified service person should remove the cover or attempt to service this device, due to possible eye injury.
- The use of controls, adjustments, or procedures other than those specified

herein might result in hazardous radiation exposure.

WARNING: To reduce the risk of fire or shock hazard, do not expose this product to rain or moisture.

	CAUTION RISK OF ELECTRIC SHOCK. DO NOT OPEN.	
CAUTION: TO REDUCE THE RISK OF ELECTRIC SHOCK, DO NOT REMOVE COVER OR BACK. NO USER-SERVICEABLE PARTS INSIDE. REFER SERVICING TO QUALIFIED PERSONNEL.		



This symbol is intended to alert you to the presence of uninsulated dangerous voltage within the product's enclosure that might be of sufficient magnitude to constitute a risk of electric shock. Do not open the product's case.



This symbol is intended to inform you that important operating and maintenance instructions are included in the literature accompanying this product.

THE FCC WANTS YOU TO KNOW

This equipment complies with the limits for a Class B digital device as specified in Part 15 of *FCC Rules*. These limits provide reasonable protection against radio and TV interference in a residential area. However, your equipment might cause TV or radio interference even when it is operating properly. To eliminate interference, you can try one or more of the following corrective measures:

- reorient or relocate the receiving antenna
- increase the distance between the equipment and the radio or TV
- use outlets on different electrical circuits for the equipment and the radio or TV

Consult your local RadioShack store if the problem still exists.

□ A Quick Look at Your System

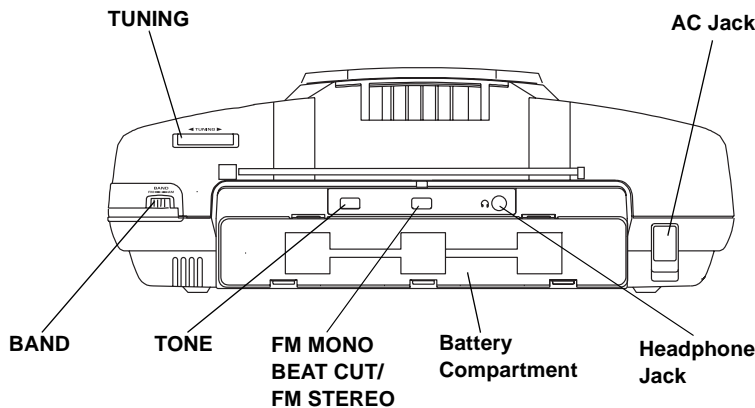

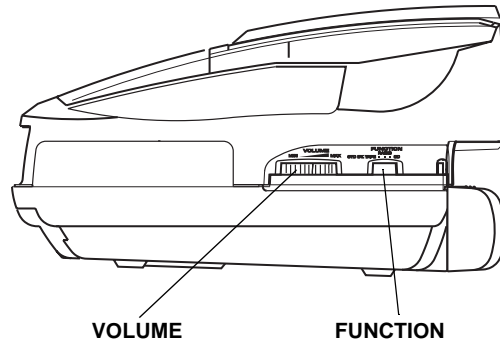

□ Preparation

CONNECTING POWER

You can power your system from either of these sources:

- standard AC power, using the supplied AC power cord
- internal battery power, using eight C batteries (not supplied)

CONNECTING AC POWER

Plug the supplied AC power cord into the AC jack on the back of the system, then plug the other end into a standard AC outlet.

Cautions:

- Always connect the AC power cord to the system before you connect it to AC power. When you finish, disconnect the power cord from AC power before you disconnect it from the system.
- Both ends of your system's power cord are designed to fit only one way. If you have difficulty connecting the power cord to the AC jack or the plug into the outlet, do not force it! Turn the power cord and try again.

Connecting the power cord to the system automatically disconnects the internal batteries.

INSTALLING BATTERIES

You can power your system with eight C batteries. For the best performance and longest life, we recommend RadioShack alkaline batteries.

Cautions:

- Use only fresh batteries of the required size and recommended type.
- Do not mix old and new batteries, different types of batteries (standard, alkaline, or rechargeable), or rechargeable batteries of different capacities.

Follow these steps to install batteries into the system.

1. Press down the tabs on the battery compartment cover, and pull the cover to remove it.
2. Place the batteries in the compartment as indicated by the polarity symbols (+ and -) marked outside the compartment.



3. Replace the cover.

When your system's sound weakens or distorts, replace the batteries.

Cautions:

- Dispose of old batteries promptly and properly. Do not burn or bury them.
- If you do not plan to use the system with batteries for a month or more, or if you plan to use only AC power, remove the batteries. Batteries can leak chemicals that can destroy electronic parts.

USING HEADPHONES/ EARPHONES

For private listening, you can connect stereo headphones (not supplied) or an earphone with a 1/8-inch (3.5-mm) plug into the  jack. Your local RadioShack store carries a wide selection of stereo headphones and earphones.

Note: Connecting headphones or an earphone automatically disconnects the built-in speaker.

Listening Safely

To protect your hearing, follow these guidelines when you use headphones or earphones.

- Set the volume to the lowest setting before you begin listening. After you begin listening, adjust the volume to a comfortable level.
- Do not listen at extremely high volume levels. Extended high-volume listening can lead to permanent hearing loss.
- Once you set the volume, do not increase it. Over time, your ears adapt to the volume level, so a volume level that does not cause discomfort might still damage your hearing.

USING THE CARRYING HANDLE

For easy carrying, pull out the portable handle under the cassette deck. When you finish, replace it.

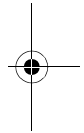
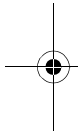

Radio Operation

1. Set **FUNCTION** to **RADIO**.
2. Slide **BAND** to **AM** or **FM**. Set **FM MONO BEAT CUT/FM STEREO** to **FM STEREO** for FM stereo sound or to **FM MONO** for monaural sound. When **FM MONO BEAT CUT/FM STEREO** is set to **FM STEREO**, the FM ST./PROG indicator lights.
3. Adjust **TUNING** to the desired station.

Notes:

- For the best FM reception, fully extend the telescoping antenna and

swivel it to the position that produces the best reception. For the best AM reception, rotate the system to position the built-in AM antenna.

- If FM stereo reception gets weak while **FM MONO BEAT CUT/FM STEREO** is set to **FM STEREO**, set **FM MONO BEAT CUT/FM STEREO** to **FM MONO**. The sound is no longer in stereo, but reception should improve.
4. Adjust **VOLUME** to a comfortable level.

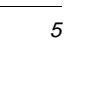
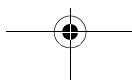

5. Slide **TONE** to **HIGH** to emphasize the treble sounds or to **LOW** to emphasize the bass sounds.

6. To turn off the radio, set **FUNCTION** to **STD BY.TAPE**.

□ **CD Player Operation**

LOADING AND PLAYING A CD

1. Set **FUNCTION** to **CD**. -- flashes on the display, then 00 appears.
2. Open the CD door by lifting the tab on the left of the door. Place a CD in the center with label facing up, press it down over the hub to secure it, and then close the door. -- flashes for a couple of seconds, then the total number of tracks appears on the display.
3. Press ►|| to play all the tracks in order, starting with Track 1. The current track number appears on the display and the play/pause indicator (the dot to the right of the track number) lights.

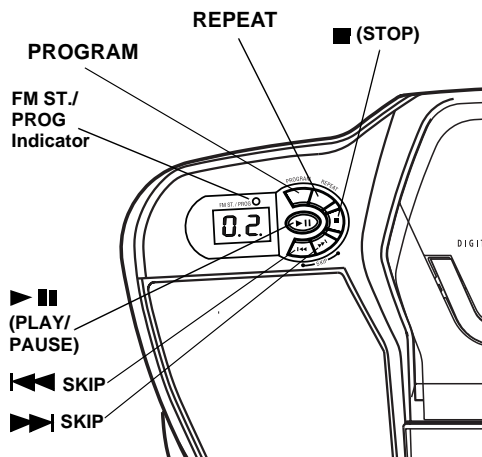

4. To temporarily pause the CD, press ►|| and the play/pause indicator flashes. To resume play, press ►|| again.

5. Adjust **VOLUME** to a comfortable level. Adjust **TONE** to **HIGH** to emphasize treble sounds or to **LOW** to emphasize bass sounds.
6. The CD stops after playing the last track. To stop play sooner, press ■. Wait a few seconds for the CD to stop turning, then open the CD door and remove the CD.

USING AUTOMATIC SEARCH MUSIC SYSTEM

The automatic search music system lets you quickly locate the beginning of any track on the CD, including the current track.

If the CD is playing:

- Press ◀◀ once to return the beginning of the current track
- Press ◀◀ twice to return the beginning of the previous track
- Press ▶▶ to skip to the beginning of the next track

If the CD is stopped, repeatedly press or hold down ◀◀ or ▶▶ until the display shows the desired track number, then press ►||. The CD player starts playing the selected track.

To search backward or forward within a track while the CD is playing, hold down either ◀◀ or ▶▶. You hear the track play rapidly and at a lower volume. Release the button to resume normal play.

USING REPEAT PLAY

The system lets you continuously repeat a single track, all tracks on a CD, or an entire programmed sequence of tracks.

To continuously repeat a single track, press **REPEAT** once so the repeat indicator in front of the right digit of the track number flashes.

To continuously repeat all tracks on the CD, press **REPEAT** twice so the repeat indicator in front of the track number lights.

To continuously repeat an entire programmed sequence, first program the tracks you want to play (see "Programming Tracks"), press **▶||** then **REPEAT** twice, so the repeat indicator lights.

To cancel repeat play during play, repeatedly press **REPEAT** until the indicator turns off. The CD player resumes normal play.

The repeat indicator remains lit after **■** is pressed. To cancel repeat play when the CD is stopped, press **■** again or **REPEAT** once.

PROGRAMMING TRACKS

You can program the system to play up to 16 tracks in any order you choose, and you can program the same track to play more than once.

Storing/Playing a Programmed Sequence

1. With a CD loaded but not playing, press **PROGRAM**. **Pr** flashes on the display and the FM ST./PROG indicator flashes.
2. Repeatedly press **SKIP ◀◀** or **SKIP ▶▶** until the desired track number appears.
3. To store the selected track, press **PROGRAM**. **Pr** flashes on the display and the FM ST./PROG indicator flashes.

4. Repeat Steps 2–3 to store up to 16 tracks.

Note: If you try to store more than 16 tracks, the 17th track is not stored and **Pr** flashes on the display.

5. Press **▶||** to play the programmed tracks. The first programmed track number appears and the play/pause indicator and the FM ST./PROG indicator lights. The CD begins to play starting with the first programmed track.

Reviewing a Programmed Sequence

To review a programmed sequence, with play stopped, press **PROGRAM** once (if you have stored all the tracks in the sequence). Otherwise, press **PROGRAM** twice. The FM ST./PROG indicator flashes and the track number of each stored track appears.

Erasing a Programmed Sequence

You can do any of the following to erase a programmed sequence:

- Set **FUNCTION** to **STD BY.TAPE** or **RADIO**.
- Open the CD door with play stopped.
- Press **■** with play stopped.

CD AND CD PLAYER TIPS

Even though a compact disc is durable, treat the CD surface with care.

- Do not write on either side of the CD, particularly the non-label side. Signals are read from the non-label side.
- Do not store CDs in high temperature, high-humidity locations. They might warp.
- Keep CDs dry. A water drop can act as a lens and affect the laser beam's focus.

- Always handle a CD by the edges to avoid fingerprints and always keep it in its protective case or sleeve when it is not in use. Fingerprints and scratches on the CD's surface can prevent the laser beam from correctly reading the digital information. If the CD gets scratched, use RadioShack Scratch 'n Fix to repair the disc.

If the radio is subjected to a sudden shock or jolt during play, the CD's rotation speed might be briefly interrupted. This is not a malfunction.

Cautions:

- To avoid damaging the CD player, do not place anything but a CD in the CD compartment.
- Remove any loaded CD from the CD compartment before moving the system to avoid damaging the CD.
- Moving the radio suddenly from a cold place to a warmer one can cause moisture to form on the CD player's pickup lens and disrupt operation. If this happens, unplug the radio, then wait about an hour before plugging it back in and playing a CD.

□ **Cassette Deck Operation**

LOADING AND PLAYING A TAPE

1. Slide **FUNCTION** to **STD BY.TAPE**.
2. Press **■▲** to open the cassette door. Load a cassette tape into the guides on the door with the side you want to play facing up and the exposed tape edge facing you. Close the door.

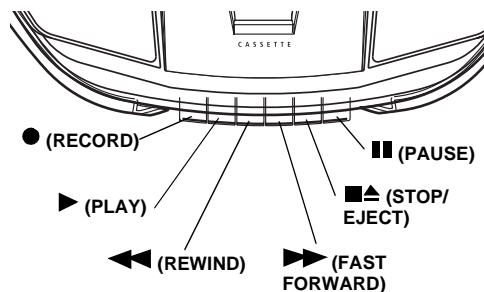

3. Press **▶** to play the tape.

Note: To temporarily pause play, press **||**. Press **||** again to resume play.

4. Adjust **VOLUME** to a comfortable level. Adjust **TONE** to **HIGH** to increase treble sounds or to **LOW** to increase bass sounds.
5. The cassette deck automatically stops the tape when it reaches the end. To stop it sooner, press **■▲**.

To fast forward when the tape is stopped, press **▶▶**, or rewind by pressing **◀◀**.

RECORDING

Notes:

- The system's Automatic Level Control (ALC) automatically adjusts the recording level. **VOLUME** has no effect on recording.
- Tape quality greatly affects the quality of the recording. We recommend regular length (60- or 90-minutes) cassette tapes. We do not recommend long-play cassette tapes such as C-120s because they are thin and can tangle easily. For

low-noise, wide-range recordings, use normal bias tape.

- Before you load a cassette tape for recording, turn the cassette's hub with your finger or a pencil to move the tape past its leader.
- Before recording, be sure the erase protection tabs are in place on the cassette tape you are using to record. See "Preventing Accidental Erasure" on Page 10.
- If you try to record on a tape that has had its erase protection tabs removed, you cannot press ●. Do not force it, as this can damage the mechanism.

Recording from the CD Player

1. Set **FUNCTION** to **CD**.
2. Load the cassette you want to record on into the cassette compartment. Load a CD into the CD compartment.
3. If you want to begin recording on a different track besides the first, press **SKIP** ►► on the CD player until the desired track number appears, then press ►►. The cassette deck starts recording and the CD starts to play the first track or the track you selected.

Notes:

- To temporarily pause recording, press ►► on the cassette deck. Press ►► again to resume recording.
 - If you also want to pause the CD player, press ►►. Press ►► again to resume playing the CD.
 - If you hold down **SKIP** ◀◀ or ►► to search within a track during recording, the cassette deck will record the sound.
4. To stop recording before the tape reaches the end, press ►▲ on the cassette deck.

5. To stop the CD player before it automatically stops, press ■ on the CD player.

Recording from the Radio

1. Follow Steps 1–4 in "Radio Operation" on Page 5.
2. Insert a blank cassette tape, or one you want to record over, into the cassette compartment.
3. Press ● on the cassette deck. The cassette deck starts recording from the radio.

Notes:

- To temporarily pause recording, press ►► on the cassette deck. Press ►► again to resume recording.
 - To reduce a whistling sound (called an *AM beat*) heard during a recording from an AM broadcast, slide **BEAT CUT** to the position that produces the best quality recording.
4. To stop recording before the tape reaches the end, press ►▲ on the cassette deck.

TAPE TIPS

Erasing a Cassette Tape

To erase a previously recorded tape, simply record over it. To erase an entire side of a cassette tape, set **FUNCTION** to **CD** and do not load a CD. Then start recording and let the tape record to the end. Or, set **FUNCTION** to **TAPE** and press ●.

To quickly erase both sides of a cassette tape, use a bulk tape eraser, available at your local RadioShack store.



Preventing Accidental Erasure

Cassette tapes have two erase-protection tabs — one for each side. To protect a recording from being accidentally recorded over or erased, use a screwdriver to remove one or both erase-protection tabs.

If you want to record on a tape's side after you have removed the erase-protection tab, place a piece of strong plastic tape over that side's erase-protection hole. Be sure you cover only the hole originally covered by the erase-protection tab.

Note: Removing erase-protection tabs does not prevent a bulk eraser from erasing a cassette tape.

Restoring Tape Tension and Sound Quality

After you play a cassette tape several times, the tape might become tightly wound on the reels. This can cause playback sound quality to deteriorate.

To restore the sound quality, fast-forward the tape from the beginning to the end of one side, then completely rewind it. Then loosen the tape reels by gently tapping each edge of the cassette on a flat surface.

Caution: Be careful not to damage the cassette when tapping it. Do not touch the exposed tape or allow any sharp objects near the cassette.

Care and Maintenance

To enjoy your AM/FM/CD/Cassette Portable for a long time:

- Keep the system dry. If it gets wet, wipe it dry immediately.
- Use and store the system only in normal temperature environments.
- Handle the system gently and carefully. Do not drop it.
- Keep the system away from dust and dirt.
- Wipe the system with a damp cloth occasionally to keep it looking new.

Modifying or tampering with the system's internal components can cause a malfunction and might invalidate its warranty. If your system is not performing as it should, take it to your local RadioShack store for assistance.

CLEANING THE TAPE-HANDLING PARTS

Dirt, dust or particles of the tape's coating can accumulate on the tape heads and other parts that the tape touches. This can greatly reduce the performance of the cassette player. After every 20 hours of tape player operation, use a RadioShack cassette deck cleaning kit to clean the tape heads.

Your local RadioShack store sells a complete line of cassette deck cleaning supplies.

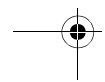
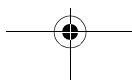

□ Specifications

GENERAL

Power Supply	120V AC 60 Hz or eight C batteries
Tuning Range	AM 530 through 1710 kHz FM 88 through 108 MHz
Speaker size	3 ¹ / ₂ inch (88.9 mm)
Dimensions (HWD)	5 ⁹ / ₁₆ × 14 ⁷ / ₈ × 10 ³ / ₈ Inches (141.3 × 377.8 × 263.5 mm)
Weight	81.13 oz (2.3 kg)
Included Accessories	AC power cord

CD PLAYER

Number of Programmable Tracks	16
Frequency Response	100 Hz – 20 kHz ±1 dB
Flat	BPFA=70
Dynamic Range	80 dB
Signal-to-Noise	60 dB
Distortion (measured at .12%).....	0.05%
Channel Separation:	
1 kHz	50 dB
20 kHz	35 dB

CASSETTE DECK

Wow and Flutter:	
Limit3%
Measured09 – .19%
Frequency Response, Limit:	
R/P	200 Hz ±4/-3 dB, 7 kHz ±3 dB
P/B	125 Hz ±4 dB, 6.3 kHz ±6 dB
Frequency Response, Measured:	
R/P	-0.5/0 dB, -1/-2 dB
P/B	-0.3/+0.1 dB, -1.3/-1.2 dB
Recording System	AC Bias
Erase System	Magnet
Power Output	1.2W

Specifications are typical; individual systems might vary. Specifications are subject to change and improvement without notice.

Limited Ninety-Day Warranty

This product is warranted by RadioShack against manufacturing defects in material and workmanship under normal use for ninety (90) days from the date of purchase from RadioShack company-owned stores and authorized RadioShack franchisees and dealers. EXCEPT AS PROVIDED HEREIN, RadioShack MAKES NO EXPRESS WARRANTIES AND ANY IMPLIED WARRANTIES, INCLUDING THOSE OF MERCHANTABILITY AND FITNESS FOR A PARTICULAR PURPOSE, ARE LIMITED IN DURATION TO THE DURATION OF THE WRITTEN LIMITED WARRANTIES CONTAINED HEREIN. EXCEPT AS PROVIDED HEREIN, RadioShack SHALL HAVE NO LIABILITY OR RESPONSIBILITY TO CUSTOMER OR ANY OTHER PERSON OR ENTITY WITH RESPECT TO ANY LIABILITY, LOSS OR DAMAGE CAUSED DIRECTLY OR INDIRECTLY BY USE OR PERFORMANCE OF THE PRODUCT OR ARISING OUT OF ANY BREACH OF THIS WARRANTY, INCLUDING, BUT NOT LIMITED TO, ANY DAMAGES RESULTING FROM INCONVENIENCE, LOSS OF TIME, DATA, PROPERTY, REVENUE, OR PROFIT OR ANY INDIRECT, SPECIAL, INCIDENTAL, OR CONSEQUENTIAL DAMAGES, EVEN IF RadioShack HAS BEEN ADVISED OF THE POSSIBILITY OF SUCH DAMAGES.

Some states do not allow limitations on how long an implied warranty lasts or the exclusion or limitation of incidental or consequential damages, so the above limitations or exclusions may not apply to you.

In the event of a product defect during the warranty period, take the product and the RadioShack sales receipt as proof of purchase date to any RadioShack store. RadioShack will, at its option, unless otherwise provided by law: (a) correct the defect by product repair without charge for parts and labor; (b) replace the product with one of the same or similar design; or (c) refund the purchase price. All replaced parts and products, and products on which a refund is made, become the property of RadioShack. New or reconditioned parts and products may be used in the performance of warranty service. Repaired or replaced parts and products are warranted for the remainder of the original warranty period. You will be charged for repair or replacement of the product made after the expiration of the warranty period.

This warranty does not cover: (a) damage or failure caused by or attributable to acts of God, abuse, accident, misuse, improper or abnormal usage, failure to follow instructions, improper installation or maintenance, alteration, lightning or other incidence of excess voltage or current; (b) any repairs other than those provided by a RadioShack Authorized Service Facility; (c) consumables such as fuses or batteries; (d) cosmetic damage; (e) transportation, shipping or insurance costs; or (f) costs of product removal, installation, set-up service adjustment or reinstallation.

This warranty gives you specific legal rights, and you may also have other rights which vary from state to state.

RadioShack Customer Relations, 200 Taylor Street, 6th Floor, Fort Worth, TX 76102

We Service What We Sell

12/99

RadioShack Corporation
Fort Worth, Texas 76102

14-518
10A00
Printed in China

Free Manuals Download Website

<http://myh66.com>

<http://usermanuals.us>

<http://www.somanuals.com>

<http://www.4manuals.cc>

<http://www.manual-lib.com>

<http://www.404manual.com>

<http://www.luxmanual.com>

<http://aubethermostatmanual.com>

Golf course search by state

<http://golfingnear.com>

Email search by domain

<http://emailbydomain.com>

Auto manuals search

<http://auto.somanuals.com>

TV manuals search

<http://tv.somanuals.com>