

Micro Hi-Fi Component System

Operating Instructions

Owner's Record

The model and serial numbers are located on the rear of the unit. Record the serial number in the space provided below. Refer to them whenever you call upon your Sony dealer regarding this product.

Model No. _____ Serial No. _____



*CMT-CP555
CMT-CPX22*

WARNING

To prevent fire or shock hazard, do not expose the unit to rain or moisture.

To prevent fire, do not cover the ventilation of the apparatus with news papers, table-cloths, curtains, etc. And don't place lighted candles on the apparatus.

To prevent fire or shock hazard, do not place objects filled with liquids, such as vases, on the apparatus.

Do not install the appliance in a confined space, such as a bookcase or built-in cabinet.

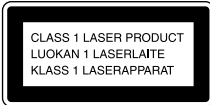

This appliance is classified as a CLASS 1 LASER product. This marking is located on the rear exterior.



Don't throw away the battery with general house waste, dispose of it correctly as chemical waste.

NOTICE FOR THE CUSTOMERS IN THE U.S.A.

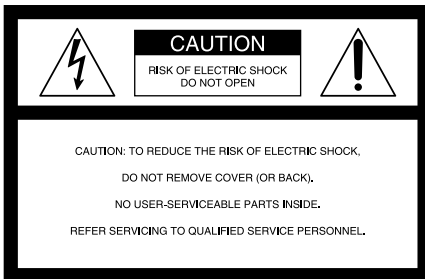

This symbol is intended to alert the user to the presence of uninsulated "dangerous voltage" within the product's enclosure that may be of sufficient magnitude to constitute a risk of electric shock to persons.



This symbol is intended to alert the user to the presence of important operating and maintenance (servicing) instructions in the literature accompanying the appliance.

CAUTION

The use of optical instruments with this product will increase eye hazard.

As the laser beam used in this CD player is harmful to eyes, do not attempt to disassemble the cabinet. Refer servicing to qualified personnel only.

WARNING

This equipment has been tested and found to comply with the limits for a Class B digital device, pursuant to Part 15 of the FCC Rules. These limits are designed to provide reasonable protection against harmful interference in a residential installation. This equipment generates, uses, and can radiate radio frequency energy and, if not installed and used in accordance with the instructions, may cause harmful interference to radio communications. However, there is no guarantee that interference will not occur in a particular installation. If this equipment does cause harmful interference to radio or television reception, which can be determined by turning the equipment off and on, the user is encouraged to try to correct the interference by one or more of the following measures:

- Reorient or relocate the receiving antenna.
- Increase the separation between the equipment and receiver.
- Connect the equipment into an outlet on a circuit different from that to which the receiver is connected.
- Consult the dealer or an experienced radio/TV technician for help.

CAUTION

You are cautioned that any changes or modifications not expressly approved in this manual could void your authority to operate this equipment.

Note to CATV system installer:

This reminder is provided to call the CATV system installer's attention to Article 820-40 of the NEC that provides guidelines for proper grounding and, in particular, specifies that the cable ground shall be connected to the grounding system of the building, as close to the point of cable entry as practical.

CAUTION

The use of optical instruments with this product will increase eye hazard.

Except for European model



ENERGY STAR[®] is a U.S. registered mark. As an ENERGY STAR[®] partner, Sony Corporation has determined that this product meets the ENERGY STAR[®] guidelines for energy efficiency.

Table of Contents

How to use this manual.....	4
Playable discs.....	4

Getting Started

Hooking up the system.....	6
Setting the clock.....	8

CD/MP3 – Play

Loading a disc.....	9
Playing a disc.....	9
— Normal Play/Shuffle Play	
Playing repeatedly.....	11
— Repeat Play	
Creating your own program.....	11
— Program Play	

Tuner

Presetting radio stations.....	12
Listening to the radio.....	14
— Preset Tuning	
— Manual Tuning	
Using the Radio Data System (RDS)....	15
(European model only)	

Tape – Play

Loading a tape.....	16
Playing a tape.....	16

Tape – Recording

Recording your favorite CD tracks on a tape.....	17
— CD-TAPE Synchro Recording	
Recording on a tape manually.....	18
— Manual Recording	

Sound Adjustment

Adjusting the sound.....	19
--------------------------	----

Timer

Falling asleep to music.....	20
— Sleep Timer	
Waking up to music.....	21
— Play Timer	
Timer recording radio programs.....	22
— Rec Timer	

Display

Turning off the display.....	23
— Power Saving Mode	
Adjusting the brightness of the display back light.....	23
Viewing information about the disc in the display.....	24

Optional Components

Hooking up optional components.....	25
Listening to audio from a connected component.....	26
Recording on a connected component.....	26

Troubleshooting

Problems and remedies.....	27
Messages.....	30

Additional Information

Precautions.....	31
Specifications.....	32
List of button locations and reference pages.....	35





How to use this manual

This manual mainly explains operations using the remote, but the same operations can also be performed using the buttons on the unit having the same or similar names.

Playable discs

You can play back the following discs on this system. Other discs cannot be played back.

List of playable discs

Format of discs	Disc logo
Audio CDs	
CD-R/CD-RW (audio data/MP3 files)	   

Discs that this system cannot play

- CD-ROMs
- CD-Rs/CD-RWs other than those recorded in the following formats:
 - music CD format
 - MP3 format that conforms to ISO9660¹⁾ Level 1/Level 2, Joliet or Multi Session²⁾
- A disc that has a non-standard shape (e.g., card, heart).
- A disc with paper or stickers on it.
- A disc that has the adhesive, cellophane tape, or a sticker still left on it.
- Data part of CD-Extras³⁾
- Data track of Mixed CDs⁴⁾

1) ISO9660 Format

The most common international standard for the logical format of files and folders on a CD-ROM. There are several specification levels. In Level 1, file names must be in the 8.3 format (no more than eight characters in the name, no more than three characters in the extension “.MP3”) and in capital letters. Folder names can be no longer than eight characters. There can be no more than eight nested folder levels. Level 2 specifications allow file names and folder names up to 31 characters long. Each folder can have up to 8 trees.

For Joliet in the expansion format (file and folder names can have up to 64 characters) make sure of the contents of the writing software, etc.

2) Multi Session

This is a recording method that enables adding of data using the Track-At-Once method.

Conventional CDs begin at a CD control area called the Lead-in and end at an area called Lead-out. A Multi Session CD is a CD having multiple sessions, with each segment from Lead-in to Lead-out regarded as a single session.

3) CD-Extra: This format records audio (audio CD data) on the tracks in session 1 and data on the tracks in session 2.

4) Mixed CD: This format records data on the first track and audio (audio CD data) on the second and subsequent tracks of a session.

Notes on CD-R and CD-RW

- Some CD-Rs or CD-RWs cannot be played on this system depending upon the recording quality or physical condition of the disc, or the characteristics of the recording device. Furthermore, the disc will not play if it has not been correctly finalized. For more information, see the operating instructions for the recording device.
- Discs recorded on CD-R/CD-RW drives may not be played back because of scratches, dirt, recording condition or the driver's characteristics.
- CD-R and CD-RW discs recorded in multi-session that have not ended by "closing the session" are not supported.
- The system may be unable to play MP3 format files that do not have the ".MP3" extension.
- Attempting to play non-MP3 format files that have the ".MP3" extension may result in noise or malfunction.
- With formats other than ISO9660 level 1 and 2, folder names or file names may not be displayed correctly.
- The following discs take a longer time to start playback.
 - a disc recorded with complicated tree structure.
 - a disc recorded in Multi Session.
 - a disc to which data can be added (non-finalized disc).

Music discs encoded with copyright protection technologies

This product is designed to playback discs that conform to the Compact Disc (CD) standard. Recently, various music discs encoded with copyright protection technologies are marketed by some record companies. Please be aware that among those discs, there are some that do not conform to the CD standard and may not be playable by this product.

Cautions when playing a disc that is recorded in Multi Session

- If the disc begins with a CD-DA session, it is recognized as a CD-DA (audio) disc, and playback continues until an MP3 session is encountered.
- If the disc begins with an MP3 session, it is recognized as an MP3 disc, and playback continues until a CD-DA (audio) session is encountered.
- The playback range of an MP3 disc is determined by the tree structure of files produced by analyzing of the disc.
- A disc with a mixed CD format will be recognized as a CD-DA (audio) disc.

Getting Started

Hooking up the system

Perform the following procedures **1** to **4** to hook up your system using the supplied cords and accessories. CMT-CPX22 is used for illustration purpose.

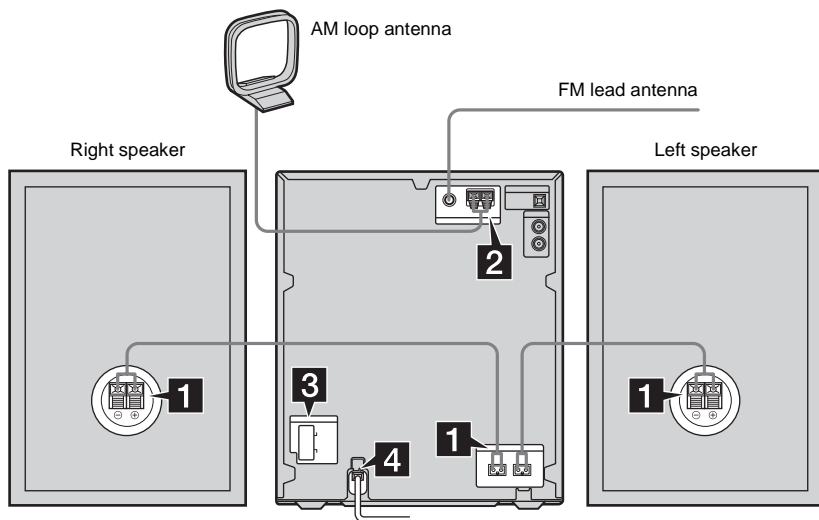

1 Connect the speakers.

Connect the right and left speaker cords to the SPEAKER terminals on the unit and to the terminals on the speakers (CMT-CPX22 only) as shown below.

Main Unit

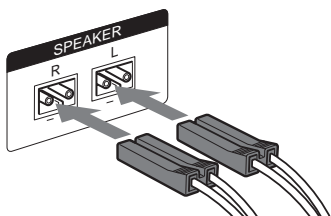

Speakers (CMT-CPX22 only)

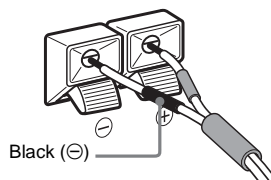

2 Connect the FM and AM antennas.

Set up the AM loop antenna, then connect it.

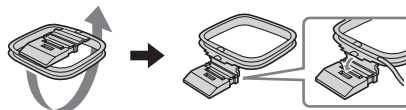

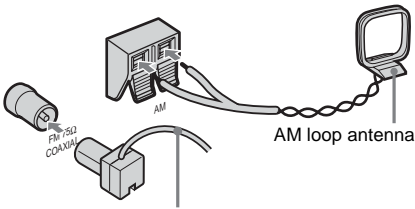

Extend the FM lead antenna horizontally

Note

Keep the antennas away from the speaker cords.

- 3 For models with a voltage selector, set VOLTAGE SELECTOR to the local power line voltage.**

Refer to the print on your system's VOLTAGE SELECTOR for available settings.

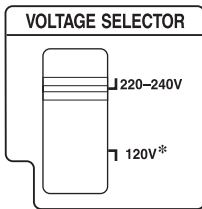

* Saudi Arabian model: 120 – 127 V

- 4 Connect the power cord to a wall outlet.**

The demonstration appears in the display. When you press I/⏻, the system turns on and the demonstration automatically ends. If the plug does not fit the wall socket, detach the supplied plug adaptor (only for models equipped with an adaptor).

Inserting two R6 (size AA) batteries into the remote

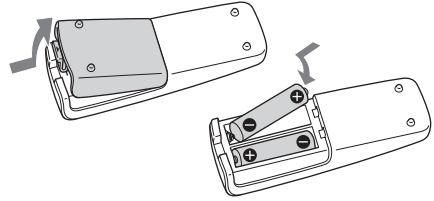

Note

If you do not use the remote for a long period of time, remove the batteries to avoid possible damage from battery leakage and corrosion.

Tip

With normal use, the batteries should last for about six months. When the remote no longer operates the system, replace both batteries with new ones.

Attaching the speaker pads

Attach the supplied speaker pads to the bottom of the speakers to stabilize the speakers and prevent them from slipping.

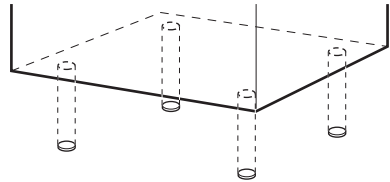

When carrying this system

Perform the following procedure to protect the CD mechanism.

Use buttons on the unit for the operation.

- 1 Make sure that all discs are removed from the system.
- 2 Press CD.
- 3 Hold down ■ and then press CD until "LOCK" appears.
- 4 Unplug the power cord.

Setting the clock

Use buttons on the remote for the operation.

- 1** Press I/⏻ to turn on the unit.
- 2** Press CLOCK/TIMER SET.
- 3** Press I◀◀ or ▶▶I repeatedly to set the hour.
- 4** Press ENTER.
- 5** Press I◀◀ or ▶▶I repeatedly to set the minute.
- 6** Press ENTER.

The clock starts working.

To adjust the clock

- 1** Press CLOCK/TIMER SET.
- 2** Press I◀◀ or ▶▶I repeatedly to select "CLOCK SET?", then press ENTER.
- 3** Do the same procedures as step 3 to 6 above.

Note

The clock is not displayed in Power Saving Mode.

Loading a disc

Use buttons on the unit for the operation.

1 Press DISC 1 – 5 to select the disc tray.

When no disc is in the disc tray you selected, “No Disc” appears. Perform step 2 while “DISC-1” (eg., 2 – 5) flashes.

2 Press CD ▲.

3 Place a disc with the label side up on the disc tray.

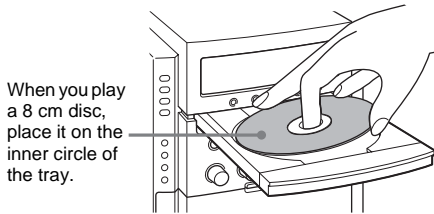

When you play a 8 cm disc, place it on the inner circle of the tray.

4 Press CD ▲ again to close the disc tray.

Notes

- Do not use a disc with tape, seals or paste on it as this may cause malfunction.
- Do not forcibly press the disc tray closed with your finger, as this may cause malfunction.

Playing a disc

— Normal Play/Shuffle Play

This system lets you play audio CDs and discs with MP3 audio tracks.

Example: When a disc is loaded

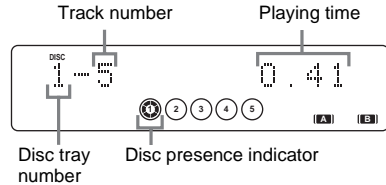

1 Press CD (or FUNCTION repeatedly) to switch the function to CD.

2 Press PLAY MODE repeatedly in stop mode until the mode you want appears in the display.

Select	To play
ALL DISCS (Normal Play)	All discs in the disc tray continuously.
1DISC (Normal Play)	The tracks on the disc you have selected in original order.
ALBM (Normal Play)	All MP3 audio tracks in the album on the disc you have selected in original order. When playing a non-MP3 disc, Album Play performs the same operation as 1DISC Play.
ALL DISCS SHUF (Shuffle Play)	The tracks on all discs in random order.
1DISC SHUF (Shuffle Play)	The tracks on the disc you have selected in random order.
ALBM SHUF (Shuffle Play)	The MP3 audio tracks in the album on the disc you have selected in random order. When playing a non-MP3 disc, Album Shuffle Play performs the same operation as 1DISC SHUF Play.
PGM (Program Play)	The tracks on the disc in the order you want them to be played (see “Creating your own program” on page 11).

continued

3 Press ► (or ◀► on the unit).

Other operations

To	Do this
Stop play	Press ■.
Pause	Press ■■. Press again to resume play.
Select a track	Press ◀◀ or ▶▶ repeatedly.
Select an album of MP3*	Press ALBUM – or + repeatedly after step 2.
Find a point in a track	Keep pressing ◀◀ or ▶▶ during playback and release it at the desired point.
Select a disc in stop mode	Press DISC SKIP (or DISC 1 – 5 on the unit).
Switch to CD function from another source	Press DISC 1 – 5 on the unit (Automatic Source Selection).
Remove a disc	Press DISC 1 – 5 on the unit, then press CD ▲ on the unit.

* You may not be able to search between multiple files. Also, the time may not be displayed correctly for some files.

Notes

- You cannot change the play mode during playback.
- Some time may be needed to start playback of discs recorded in complex configurations such as many layers.
- When the disc is inserted, the player reads all the tracks on that disc. If there are many albums or non-MP3 audio tracks on the disc, it may take a long time for play to begin or for the next MP3 audio track to start play.
- Do not save unnecessary albums or tracks other than MP3 ones in the disc to be used for MP3 listening. We recommend that you do not save other types of tracks or unnecessary albums on a disc that has MP3 audio tracks.
- An album that does not include an MP3 audio track is skipped.
- Maximum album number: 150 (including root folder)
- The maximum number of MP3 audio tracks and albums that can be contained on a single disc is 300.
- Playback is possible up to 8 levels.
- MP3 audio tracks are played back in the order that they are recorded on the disc.
- Depending on the encoding/writing software, recording device, or the recording media used at the time an MP3 audio track is recorded, you may encounter such problems as disabled playback, sound interruptions, and noise.

Tip

When disc access takes a long time, set “CD POWER ON” by CD power manage function (page 13).

Playing repeatedly

— Repeat Play

You can play all the tracks or a single track on a disc repeatedly.

Press REPEAT repeatedly during playback until “REP” or “REP1” appears.

REP: For all the tracks on a disc, or all the MP3 audio tracks in an album up to five times.

REP1: For a single track only.

To cancel Repeat Play

Press REPEAT repeatedly until both “REP” and “REP1” disappear.

Notes

- You cannot select “REP” and “ALL DISCS SHUF” at the same time.
- When you select “REP1”, that track is repeated endlessly until “REP1” is canceled.

Creating your own program

— Program Play

You can make a program of up to 25 steps from all the discs in the order you want to play them. You can synchro record the programmed tracks onto a cassette tape (page 17).

1 Press CD (or FUNCTION repeatedly) to switch the function to CD.

2 Press PLAY MODE in stop mode repeatedly until “PGM” appears.

3 Press DISC SKIP (or DISC 1 – 5 on the unit) to select a disc.

To program all the tracks on a disc at once, proceed to step 5 with “AL” displayed.

4 Press ◀◀ or ▶▶ repeatedly until the desired track number appears.

When programming the MP3 audio tracks, press ALBUM – or + to select album, then press ◀◀ or ▶▶ repeatedly until the desired track number appears.

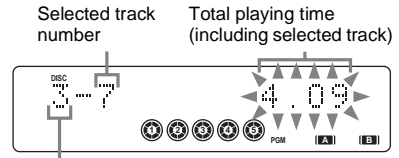

Disc tray number

5 Press ENTER.

The track is programmed.

The program step number appears, followed by the total playing time.

6 Program additional discs or tracks.

To program	Repeat steps
Other discs	3 and 5
Other tracks on the same disc	4 and 5
Other tracks on other discs	3 to 5

7 Press ▶ (or ◀▶ on the unit).

Program Play starts.

continued

Other operations

To	Do this
Cancel Program Play	Press PLAY MODE repeatedly in stop mode until "PGM" disappears.
Clear a track from the end	Press CLEAR in stop mode.

Tips

- The program you made remains after Program Play finishes. To play the same program again, press CD (or FUNCTION repeatedly) to switch the function to CD, then press ► (or ◀◀ on the unit). However, the program is cleared when you open the disc tray.
- "--:--" appears when the total CD program time exceeds 100 minutes, or when you select a CD track whose number is 21 or over, or when you select an MP3 audio track.

Tuner

Presetting radio stations

You can preset up to 20 FM stations and 10 AM stations. You can then tune in any of those stations simply by selecting the corresponding preset number.

Automatic tuning preset

You can automatically tune in all of the stations that can be received in your area and then store the radio frequency of the desired stations.

- 1 Press TUNER BAND (or FUNCTION repeatedly) to switch the function to tuner.**
- 2 Press TUNER BAND repeatedly to select "FM" or "AM".**
- 3 Press TUNING MODE repeatedly until "AUTO" appears in the display.**
- 4 Press – or + (or TUNING – or + on the unit).**

The frequency changes as the system scans for a station. Scanning stops automatically when a station is tuned in. At that time, "TUNED" and "ST" (for stereo program only) appear.

If "TUNED" does not appear and the scanning does not stop

Set the frequency of the desired radio station as described in "Manual tuning preset" (page 13).

- 5 Press TUNER MEMORY.**

The preset number flashes. Perform steps 6 and 7 while the preset number flashes.

Preset number



- 6** Press **-** or **+** (or **TUNING -** or **+** on the unit) repeatedly to select the desired preset number.
- 7** Press **ENTER**.
- 8** Repeat steps 2 through 7 to store other stations.

Tip

Press **TUNING MODE** to stop scanning.

Manual tuning preset

You can manually tune in and store the radio frequency of the desired stations.

- 1** Press **TUNER BAND** (or **FUNCTION** repeatedly) to switch the function to tuner.
- 2** Press **TUNER BAND** repeatedly to select **"FM"** or **"AM"**.
- 3** Press **TUNING MODE** repeatedly until **"AUTO"** and **"PRESET"** disappear from the display.
- 4** Press **-** or **+** (or **TUNING -** or **+** on the unit) repeatedly to tune in the desired station.
- 5** Press **TUNER MEMORY**.
- 6** Press **-** or **+** (or **TUNING -** or **+** on the unit) repeatedly to select the desired preset number.
- 7** Press **ENTER**.
- 8** Repeat steps 2 through 7 to store other stations.

Other operations

To	Do this
Tune in a station with a weak signal	Follow the procedure described in "Manual tuning preset" (page 13).
Set another station to the existing preset number	After step 5, press - or + (or TUNING - or + on the unit) repeatedly to select the preset number you want to store the station.

To improve tuner reception

When tuner reception is poor, set CD player power off by CD power manage function. CD power is factory set to on. Use buttons on the unit for the operation.

- 1** Press **CD**.
- 2** Press **I/⏻** to turn off the system.
- 3** Press **I/⏻** while holding **■**.
"CD POWER OFF" appears.

To set CD power on

Repeat the procedure above and "CD POWER ON" appears.

Notes

- When "CD POWER OFF" is selected, disc access time is increased.
- You cannot change the setting in Power Saving Mode (page 23).

To change the AM tuning interval (except for European, Russian and Saudi Arabian models)

The AM tuning interval is factory-preset to 9 kHz (or 10 kHz for some areas). To change the AM tuning interval, tune in any AM station first, then turn off the system. While holding **■**, press **I/⏻** on the unit. When you change the interval, all the AM preset stations are erased. To reset the interval, repeat the same procedure.

Note

You cannot change the AM tuning interval in Power Saving Mode (page 23).

Tips

- The preset stations are retained for about half a day even if you disconnect the power cord or if a power failure occurs.
- To improve broadcast reception, adjust the supplied antennas, or connect a commercially available external antenna.

Listening to the radio

You can listen to a radio station either by selecting a preset station, or by manually tuning in the station.

Listening to a preset station

— *Preset Tuning*

Preset radio stations in the tuner's memory first (see "Presetting radio stations" on page 12).

- 1 Press TUNER BAND (or FUNCTION repeatedly) to switch the function to tuner.**
- 2 Press TUNER BAND repeatedly to select "FM" or "AM".**
- 3 Press TUNING MODE repeatedly until "PRESET" appears in the display.**
- 4 Press – or + (or TUNING – or + on the unit) repeatedly to select the desired preset station.**

Listening to non-preset radio station

— *Manual Tuning*

- 1 Press TUNER BAND (or FUNCTION repeatedly) to switch the function to tuner.**
- 2 Press TUNER BAND repeatedly to select "FM" or "AM".**
- 3 Press TUNING MODE repeatedly until "AUTO" and "PRESET" disappear from the display.**
- 4 Press – or + (or TUNING – or + on the unit) repeatedly to tune in the desired station.**

Note

When switching to CD function from tuner, a longer time may be required to access the disc. In this case, set "CD POWER ON" by CD power manage function (page 13).

Tips

- To improve broadcast reception, adjust the supplied antennas, or connect a commercially available external antenna.
- When an FM stereo program has static noise, press FM MODE repeatedly until "MONO" appears. There will be no stereo effect, but the reception will improve.
- Press TUNING MODE repeatedly until "AUTO" appears in step 3 above, then press – or + (or TUNING – or + on the unit). The frequency indication changes and scanning stops when the system tunes in a station (Automatic Tuning).
- To record the radio programs, use manual recording (page 18).

Using the Radio Data System (RDS)

(European model only)

What is the Radio Data System?

Radio Data System (RDS) is a broadcasting service that allows radio stations to send additional information along with the regular program signal. RDS is available only on FM stations.*

Note

RDS may not work properly if the station you are tuned in is not transmitting the RDS signal properly or if the signal is weak.

* Not all FM stations provide RDS service, nor do they provide the same types of services. If you are not familiar with the RDS system, check with your local radio stations for details on RDS services in your area.

Receiving RDS broadcasts

Simply select a station from the FM band.

When you tune in a station that provides RDS services, the station name appears in the display.

To check the RDS information

Each time you press DISPLAY, the display changes cyclically as follows:

Station name* → Frequency → Program type*
→ Clock display → Bass level → Treble level

* If the RDS broadcast is not properly received, the station name or the program type may not appear in the display.

Tape – Play

Loading a tape

- 1 Press **A TAPE** \blacktriangle or **TAPE** \blacktriangle **B** on the unit.
- 2 Load a recorded/recordable tape into the cassette holder.

With the side you want to play/record facing towards you.

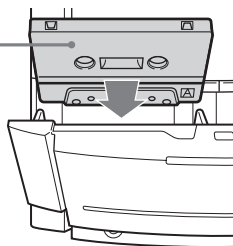

Playing a tape

You can use TYPE I (normal) tape.

- 1 Load a tape.
- 2 Press **TAPE** (or **FUNCTION** repeatedly) or **TAPE A/B** on the unit to switch the function to **TAPE**.
- 3 Press **TAPE** (or **TAPE A/B** on the unit) repeatedly to select deck **A** or **B**.
- 4 Press **PLAY MODE** repeatedly to select “ \rightleftarrows ” to play one side. Select “ \rightleftarrows ”^{*} to play both sides. Select “**RELAY**” (Relay Play)^{*} to play both decks in succession.
- 5 Press \blacktriangleright (or \blacktriangleleft) on the unit.

The tape starts playing. Press the button again to play the reverse side.

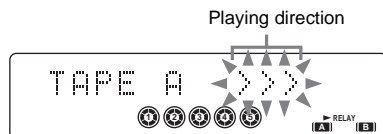

* Relay play always follow this cyclic sequence:
Deck A (front side) → Deck A (reverse side)
→ Deck B (front side) → Deck B (reverse side)

For CMT-CP555, deck A does not play the reverse side.

Other operations

To	Do this
Play the reverse side*	Press \blacktriangleright (or \blacktriangleleft) on the unit again during play.
Stop play	Press \blacksquare .
Pause	Press \mathbb{I} . Press again to resume play.
Fast-forward or rewind	Press \blacktriangleleft or \blacktriangleright in stop mode.
Remove a tape	Press A TAPE \blacktriangle or TAPE \blacktriangle B on the unit.

* For CMT-CP555, deck A does not play the reverse side.

Searching for the beginning of the current or the previous or the next track (AMS)*

To go forward

Press ►► during play.

Each time you press the button, the search direction, + (forward), and number of tracks being skipped (1 to 9) appear.

To go back

Press ◀◀ during playback.

Each time you press the button, the search direction, – (back), and number of tracks being skipped (1 to 9) appear.

* AMS (Automatic Music Sensor)

Note

The AMS function may not operate correctly under the following circumstances:

- When the unrecorded space between songs is less than 4 seconds long.
- When the system is placed near a television.

Tips

- If you select “◀↔▶” or “RELAY”*, the deck stops automatically after repeating the sequence five times.
- When a tape is inserted, corresponding forward (▶) / reverse (◀) indicators light.

* For CMT-CP555, deck A does not play the reverse side.

Tape – Recording

Recording your favorite CD tracks on a tape

— CD-TAPE Synchro Recording

You can record a whole CD on a tape. You can use TYPE I (normal) tape. The recording level is adjusted automatically. Use buttons on the unit for the operation.

- 1 Load a recordable tape into deck B.**
- 2 Press TAPE A/B to select deck B, then press ◀▶ repeatedly to select recording side. And press ■ to stop playback.**
- 3 Press PLAY MODE on the remote repeatedly to select “↔” to record on one side. Select “◀↔▶” (or “RELAY”) to record on both sides.**
- 4 Press CD and load a disc you want to record.**
When you want to record an album from an MP3 disc, be sure to press ALBUM – or + to select the desired album before proceeding.
- 5 Press CD SYNC.**
Deck B stands by for recording. “REC” flashes.
- 6 Press ● START.**
Recording starts.

To stop recording

Press ■.

To record a disc by specifying track order

You can record only your favorite CD tracks using Program Play. Between steps 4 and 5, perform steps 2 to 6 of “Creating your own program” (page 11).

Tips

- When you record on both sides, be sure to start from the front side. If you start from the reverse side, recording stops at the end of the reverse side.
- If you select both sides recording and the tape reaches the end of the front side part-way through a track, the entire track is recorded again from the beginning of the reverse side.

Recording on a tape manually

— Manual Recording

You can record just the portions you like from a CD, tape or radio program on a tape.

You can also record from connected components (see “Hooking up optional components” on page 25).

Use buttons on the unit for the operation.

- 1 Load a recordable tape into deck B.**
- 2 Press TAPE A/B to select deck B, then press ◀▶ repeatedly to select recording side. And press ■ to stop playback.**
- 3 Press PLAY MODE on the remote repeatedly to select “↔” to record on one side. Select “↔↔” (or “RELAY”) to record on both sides.**
- 4 Press one of the following buttons to select the desired source to record.**
 - CD: To record from this system’s CD player.
 - TAPE A/B: To record from this system’s tape deck A.
 - TUNER/BAND: To record from this system’s tuner.
 - VIDEO/MD: To record from the optional component connected to the VIDEO/MD IN jacks.
- 5 Press ● START.**

Deck B stands by for recording.
“REC” flashes.
- 6 Press ● START, then start playing the desired source to record.**

Recording starts.

Other operations

To	Do this
Stop recording	Press ■.
Pause recording	Press ● START on the unit.

Notes

- You cannot listen to other sources while recording.
- If TAPE B is selected in step 4, silence is recorded.

Tips

- For recording from the tuner:
If noise is heard while recording from the tuner, move the respective antenna to reduce the noise.
- When you record on both sides, be sure to start from the front side. If you start from the reverse side, recording stops at the end of the reverse side.

Sound Adjustment

Adjusting the sound

Generating a more dynamic sound (Dynamic Sound Generator X-tra)

Press DSGX on the unit.

Each time you press the button, the display changes as follows:

DSGX ON ↔ DSGX OFF

Generating a more attractive sound (MP3 BOOSTER)

You can enjoy a more attractive sound when playing MP3 audio tracks.

1 Press CD (or FUNCTION repeatedly) to switch the function to CD.

2 Hold DSGX on the unit for 2 seconds.

Each time you hold the button for 2 seconds, the display changes as follows:

BOOSTER ON ↔ BOOSTER OFF

Adjusting the bass and treble

You can adjust the bass and treble to enjoy more powerful sound.

1 Press EQ repeatedly to select “BASS” or “TREBLE”.

Each time you press the button, the display changes as follows:

BASS ↔ TREBLE

2 Press ◀◀ or ▶▶ repeatedly to adjust the level while “BASS” or “TREBLE” appears.

To adjust the bass on the unit

Turn BASS control.

To adjust the treble on the unit

Turn TREBLE control.

To exit the bass and treble settings

If you do not perform any operations for 4 seconds, the display automatically returns to the original display.

Timer

Falling asleep to music

— *Sleep Timer*

You can set the system to turn off after a certain time, so that you can fall asleep to music.

Press SLEEP.

Each time you press the button, the minute display (the turn-off time) changes cyclically as follows:

AUTO* → 90min → 80min → ... → 10min
→ OFF

* The system automatically turns off in 100 minutes or after the current disc or tape finishes playing.

Other operations

To	Press
Check the remaining time*	SLEEP once.
Change the time to turn off	SLEEP repeatedly to select the time you want.
Cancel the Sleep Timer Function	SLEEP repeatedly until "OFF" appears.

* You cannot check the remaining time if you select "AUTO".

Tip

You can use the Sleep Timer, even if you have not set the clock.

Waking up to music

— Play Timer

You can wake up to music at a preset time. Make sure you have set the clock (see “Setting the clock” on page 8).

Use buttons on the remote for the operation.

- 1 Prepare the sound source you want to play.**
 - CD: Load a disc. To start from a specific track, make a program (see “Creating your own program” on page 11).
 - Tape: Load a tape (see “Playing a tape” on page 16).
 - Tuner: Tune in the preset radio station (see “Listening to the radio” on page 14).
- 2 Press VOLUME +/- to adjust the volume.**
- 3 Press CLOCK/TIMER SET.**
- 4 Press ◀◀ or ▶▶ repeatedly to select “PLAY SET?”, then press ENTER.**
“ON” appears and the hour indication flashes.
- 5 Set the time to start playing.**
Press ◀◀ or ▶▶ repeatedly to set the hour, then press ENTER.
The minute indication flashes.
Press ◀◀ or ▶▶ repeatedly to set the minute, then press ENTER.
- 6 Set the time to stop playing following the same procedure as step 5.**
- 7 Press ◀◀ or ▶▶ repeatedly until the desired sound source appears.**
Each time you press the button, the display changes cyclically as follows:

- 8 Press ENTER.**
The start time, the stop time and the sound source appear in turn, then the original display returns.
- 9 Press I/⏻ to turn off the system.**

Other operations

To	Do this
Check the setting	<ol style="list-style-type: none">1 Press CLOCK/TIMER SELECT.2 Press ◀◀ or ▶▶ repeatedly until “PLAY SELECT?” appears, then press ENTER.
Change the setting	Start over from step 1.
Cancel the timer	<ol style="list-style-type: none">1 Press CLOCK/TIMER SELECT.2 Press ◀◀ or ▶▶ repeatedly until “TIMER OFF?” appears, then press ENTER.

Notes

- You cannot activate the Play Timer and the Rec Timer at the same time.
- If you use the Play Timer and the Sleep Timer at the same time, the Sleep Timer has priority.
- Do not operate the system from the time the system turns on until the play starts (about 15 seconds before the preset time).
- If the system is on about 15 seconds before the preset time, the Play Timer will not be activated.
- You cannot use the optional component connected to VIDEO/MD IN jacks as the sound source for Play Timer.

Timer recording radio programs

— Rec Timer

You can record a preset radio station from a specified time.

To timer record, you must first preset the radio station (see “Presetting radio stations” on page 12) and set the clock (see “Setting the clock” on page 8).

Use buttons on the remote for the operation.

- 1 Tune in the preset radio station (see “Listening to a preset station” on page 14).**
- 2 Press CLOCK/TIMER SET.**
“PLAY SET?” appears.
- 3 Press ◀◀ or ▶▶ repeatedly to select “REC SET?”, then press ENTER.**
“ON” appears and the hour indication flashes.
- 4 Set the time to start recording.**
Press ◀◀ or ▶▶ repeatedly to set the hour, then press ENTER.
The minute indication flashes.
Press ◀◀ or ▶▶ repeatedly to set the minute, then press ENTER.
- 5 Set the time to stop recording following the same procedure as step 4.**
The start time, the stop time, and the preset radio station to be recorded (e.g., “TUNER FM 5”) appear in turn, before the original display returns.
- 6 Load a recordable tape into deck B.**
- 7 Press TAPE to switch the function to TAPE.**
- 8 Press PLAY MODE repeatedly until ⇄ appears to record on one side or ⇄ (or ⇄⇄) to record on both sides.**

- 9 Press ◀▶ on the unit repeatedly to select recording side.**

If you select both sides recording or front side recording, press ◀▶ to light up the >>> indicator. If you record on the reverse side, press ◀▶ again to light up the <<< indicator.

- 10 Press I/⏻ to turn off the system.**

Other operations

To	Do this
Check the setting	<ol style="list-style-type: none">1 Press CLOCK/TIMER SELECT.2 Press ◀◀ or ▶▶ repeatedly until “REC SELECT?” appears, then press ENTER.
Change the setting	Start over from step 1.
Cancel the timer	<ol style="list-style-type: none">1 Press CLOCK/TIMER SELECT.2 Press ◀◀ or ▶▶ repeatedly until “TIMER OFF?” appears, then press ENTER.

Notes

- You cannot activate the Play Timer and the Rec Timer at the same time.
- If you use the the Rec Timer and the Sleep Timer at the same time, the Sleep Timer has priority.
- Do not operate the system from the time the system turns on until the recording starts (about 15 seconds before the preset time).
- If the system is on about 15 seconds before the preset time, the Rec Timer will not be activated.
- The volume is reduced to minimum during recording.

Turning off the display

— Power Saving Mode

The demonstration display (display window and buttons lighting and flashing even when the system power is off) and the clock display can be turned off to minimize the amount of power consumed during standby (Power Saving Mode).

Press DISPLAY repeatedly while the system is off until the demonstration display or the clock display disappears.

To cancel Power Saving Mode

Press DISPLAY while the system is off. Each time you press the button, the display switches cyclically as follows:

Demonstration display → Clock display* → No display (Power Saving Mode)

* “--:--” appears if you have not set the clock.

Note

You cannot perform the following operations in Power Saving Mode.

- setting the clock
- changing the AM tuning interval (except for European, Russian and Saudi Arabian models)
- turning on the system by pressing the function buttons
- changing the CD power manage function

Tips

- I/⏻ indicator lights up even in Power Saving Mode.
- The timer continues to operate in Power Saving Mode.

Adjusting the brightness of the display back light

Press DIMMER on the unit repeatedly to select the desired setting while the system is on.

The display changes cyclically as follows:
DIMMER OFF → DIMMER 1 → DIMMER 2 → DIMMER 3*

* DIMMER 3 is the darkest.

Viewing information about the disc in the display

You can check the playing time and remaining time of the current track or that of the disc.

When a CD-TEXT disc or a disc with MP3 audio tracks is loaded, you can also check the information recorded on disc, such as the titles. When the unit detects CD-TEXT discs, the “CD TEXT” indication appears in the display.

When the unit detects MP3 discs, the “MP3” indication appears in the display.

Checking the remaining time and titles (CD/MP3)

Press DISPLAY during Normal Play.

Each time you press the button, the display changes cyclically as follows:

Current track number and elapsed playing time

→ Current track number and remaining time or

“_ _ _ _”¹⁾ → Remaining time of the disc or

“_ _ _ _”¹⁾ → Track title (CD-TEXT disc or disc with MP3 audio tracks²⁾ only) → Album name

(disc with MP3 audio tracks only) → Clock display (for eight seconds) →

Bass level (for eight seconds) → Treble level (for eight seconds)

¹⁾ For discs with MP3 audio tracks

²⁾ When you play back a track with an ID3 tag ver. 1 or ver. 2, the ID3 tag appears. The ID3 tag displays only the track title information.

Checking the total playing time and titles (CD/MP3)

Press DISPLAY in stop mode.

Each time you press the button, the display changes cyclically as follows:

■ When a CD/MP3 is in Normal Play mode

TOC display¹⁾ or total album number of the disc²⁾ or total track number of the current album³⁾ → Disc title⁴⁾ or volume label⁵⁾ or album name⁵⁾ → Clock display (for eight seconds) → Bass level (for eight seconds) → Treble level (for eight seconds)

¹⁾ TOC = Table of Contents; displays total number of tracks on the disc, and total playing time of the disc

²⁾ For discs with MP3 audio tracks in Normal play or SHUF mode

³⁾ For discs with MP3 audio tracks in ALBM or ALBM SHUF mode

⁴⁾ For discs with CD-TEXT

⁵⁾ For discs with MP3 audio tracks, album titles or volume label may not be displayed depending on the play mode

Depending on the disc, some CD-TEXT information may not appear.

■ When a CD/MP3 is in Program Play mode

The last track number of the program and the total playing time → Total track number of the program (for eight seconds) → Disc title¹⁾ or volume label²⁾ → Clock display (for eight seconds) → Bass level (for eight seconds) → Treble level (for eight seconds)

¹⁾ For discs with CD-TEXT

²⁾ For discs with MP3 audio tracks

Checking the station name (TUNER)

Press DISPLAY while listening to the radio.

Each time you press the button, the display changes cyclically as follows:

Station name → Frequency → Clock display (for eight seconds) → Bass level (for eight seconds) → Treble level (for eight seconds)

Hooking up optional components

To enhance your system, you can connect optional components. Refer to the operating instructions provided with each component.

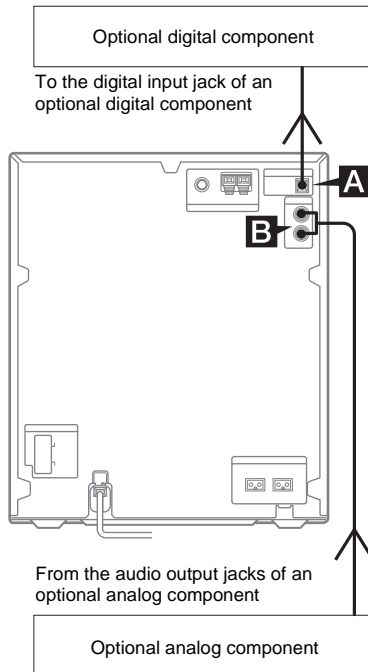

A DIGITAL (OPTICAL) OUT jack

Use a digital optical cable (square, not supplied) to connect an optional component (such as an MD deck) to this jack. You can then record digital audio from this system.

Note

There is no digital audio output from this jack during playback of MP3 audio tracks.

B VIDEO/MD IN jacks

Use audio cords (not supplied) to connect an optional analog component (MD deck or VCR, etc.) to these jacks. You can then listen to the sound from the component.

Listening to audio from a connected component

- 1 Connect the audio cords.**
See “Hooking up optional components” on page 25.
- 2 Press VIDEO/MD on the unit to switch the function to VIDEO or MD.**
Start playing the connected component.

Note

If the sound is distorted or too loud when “VIDEO” is selected or you want to switch back to “MD”, repeat the operation described above to switch to “MD”.

Tip

If you cannot select “MD” by pressing VIDEO/MD repeatedly, hold down VIDEO/MD and then press I/⏻ while the power is on. The function will change from “VIDEO” to “MD”, and “MD” will appear in the display. To change back to “VIDEO”, repeat the same procedure.

Recording on a connected component

Making a digital recording

- 1 Connect the digital optical cord.**
- 2 Start recording.**
Refer to the operating instructions of the connected component.

Note

You can digitally record from the discs only. However, you cannot record from copy prohibited discs and MP3 audio tracks.

Problems and remedies

Should you encounter a problem with your system, do the following:

- 1 Make sure the power cord and speaker cords are correctly and firmly connected.
- 2 Find your problem in the troubleshooting checklist below and take the indicated corrective action.

If the problem persists after doing all of the above, consult your nearest Sony dealer.

When the I/⏻ indicator flashes

Immediately unplug the power cord and check the following items.

- If your system has a voltage selector, is the voltage selector set to the correct voltage? Check the voltage for your region, then make sure the voltage selector is set correctly.
- Are the + and – speaker cords short-circuited?
- Are you using the supplied speakers?
- Is anything blocking the ventilation holes on the rear of the system?

Check all the above items and fix any problems found. **After I/⏻ indicator stops flashing**, reconnect the power cord and turn on the system. If the indicator still flashes, or if the cause of the problem cannot be found even after checking all the above items, consult your nearest Sony dealer.

General

The display starts flashing as soon as you plug in the power cord even though you have not turned on the system (see step 4 of “Hooking up the system” (page 6)).

- Press I/⏻ while the system is off. The demonstration disappears.

“-:- -” appears in the display.

- A power interruption has occurred. Set the clock (page 8) and timer settings (pages 21 and 22) again.

The clock setting/radio presetting/timer is canceled.

- Redo the following:
 - “Setting the clock” (page 8)
 - “Presetting radio stations” (page 12)
 - “Check the setting” (pages 21 and 22)
 - “Timer recording radio programs” (page 22)

There is no sound.

- If your system has a voltage selector, make sure the voltage selector is set to the correct voltage.
- Press VOLUME + or turn VOLUME control on the unit clockwise.
- Make sure the headphones are not connected.
- Check the speaker connections (page 6).
- There is no audio output during Rec Timer.

Sound comes from one channel, or unbalanced left and right volume.

- Place the speakers as symmetrically as possible.
- Connect the supplied speakers.

There is severe hum or noise.

- Move the system away from the source of noise.
- Connect the system to a different wall outlet.
- Install a noise filter (commercially available) to the power cord.

The timer cannot be set.

- Set the clock again (page 8).

The timer does not function.

- Check the timer setting and set the correct time (pages 21 and 22).
- Cancel the Sleep Timer Function (page 20).

The remote does not function.

- Remove the obstacle.
- Move the remote closer to the system.
- Point the remote at the system's sensor.
- Replace the batteries (R6/size AA).
- Locate the system away from the fluorescent light.

The system can not be turned on even though you have pressed I/⏻.

- Make sure the power cord is connected to wall outlet.

The color irregularity on a TV screen persists.

- Turn off the TV set once, then turn it on after 15 to 30 minutes. If the color irregularity still persists, place the speakers farther away from the TV set.

CD/MP3 player

The disc tray does not open and "LOCKED" appears.

- Contact your Sony dealer or local authorized Sony service facility.

The disc tray does not close.

- Place the disc correctly in the center of the tray.
- Always close the tray by pressing CD ▲ on the unit. Trying to press the tray closed with your fingers may cause problems with the player.

The disc does not eject.

- You cannot eject the disc during CD Synchro Recording. Press ■ to cancel the CD Synchro Recording, then press CD ▲ on the unit to eject the disc.
- Consult your nearest Sony dealer.

Play does not start.

- Check whether a disc is loaded. The disc indicator lights up when a disc is loaded.
- Wipe the disc clean (page 31).
- Replace the disc.
- Place the disc that this system can play.
- Place the disc correctly in the center of the tray.
- Place the disc in the tray with the label side up.
- Remove the disc and wipe away the moisture on the disc, then leave the system turned on for a few hours until the moisture evaporates.
- Press ► to start play.

Disc access takes a long time.

- Set "CD POWER ON" by CD power manage function (page 13).

The sound skips.

- Wipe the disc clean (page 31).
- Replace the disc.
- Try moving the system to a place without vibration (e.g., on top of a stable stand).
- Try moving the speakers away from the system, or placing them on separate stands. When you listen to a track with bass sounds at high volume, the speaker vibration may cause the sound to skip.

Play does not start from the first track.

- Press PLAY MODE repeatedly until both "PGM" and "SHUF" disappear to return to Normal Play.

MP3 audio track cannot be played back.

- Recording was not performed according to the ISO9660 level 1 or level 2 format, or Joliet in the expansion format.
- The MP3 audio track does not have the extension ".MP3".
- The data is not stored in MP3 format.
- Discs containing files other than MPEG 1, 2, 2.5 Audio Layer-3 files cannot be played.

MP3 audio tracks take longer to play back than others.

- After the system reads all tracks on the discs, playback may take more time than usual if:
 - the number of albums or tracks on the disc is very large.
 - the album and track organization structure is very complex.

The album title, track title and ID3 tag do not appear correctly.

- Use a disc that conforms with ISO9660 level 1, level 2, or Joliet in the expansion format.
- The disc ID3 tag is not ver. 1 or ver. 2.

Tuner

Severe hum or noise/stations cannot be received.

- Set the proper band and frequency (page 12).
- Connect the antenna properly (page 6).
- Find a place and an orientation that provide good reception, then set up the antenna again. If you cannot obtain good reception, we recommend you connect a commercially available external antenna.
- The supplied FM lead antenna receives signals along its entire length, so make sure you extend it fully.
- Locate the antennas as far away from the speaker cords as possible.
- Consult your nearest Sony dealer if the supplied AM antenna has come off the plastic stand.
- Try turning off surrounding electrical equipment.
- Set “CD POWER OFF” by CD power manage function (page 13).

A stereo FM program cannot be received in stereo.

- Press FM MODE until “MONO” disappears.

Tape deck

After pressing ◀▶, there is a mechanical noise, “Eject” appears in the display, and the unit enters standby mode automatically.

- Insert the cassette correctly.

The tape does not record or play, or there is a decrease in sound level.

- The heads are dirty. Clean them (page 32).
- The record/playback heads are magnetized. Demagnetize them (page 32).

The tape does not erase completely.

- The record/playback heads are magnetized. Demagnetize them (page 32).

There is excessive wow or flutter, or the sound drops out.

- The capstans in the tape deck are dirty. Clean them (page 32).

Noise increases or the high frequencies are erased.

- The record/playback heads are magnetized. Demagnetize them (page 32).

The tape does not record.

- No cassette is loaded. Load a cassette.
 - The tab has been removed from the cassette. Cover the broken tab with adhesive tape (page 32).
 - The tape has wound to the end.
-

Optional components

There is no sound.

- Refer to General item “The clock setting/radio presetting/timer is canceled.” (page 27) and check the condition of the system.
- Connect the component properly (page 25) while checking:
 - if the cords are connected properly.
 - if the cord plugs are firmly inserted all the way.
- Turn on the connected component.
- Refer to the operating instructions supplied with the connected component and start playing.
- Press FUNCTION repeatedly to select “MD” or “VIDEO” (page 26).

The sound is distorted.

- Set the volume of the connected component lower.
-

If the system still does not operate properly after performing the above measures, reset the system as follows:

- 1 Disconnect the power cord.
- 2 Reconnect the power cord.
- 3 Press I/⏻ to turn on the system.
- 4 Press ■, DIMMER and I/⏻ on the unit.

The system is reset to the factory settings. You should set the settings you made, such as the preset stations, clock, and timer.

Messages

One of the following messages may appear or flash in the display during operation.

CD/MP3

No Disc

There is no disc in the player.

OVER

You have reached the end of the disc while pressing **▶▶** during playback or pause.

Push STOP!

You pressed **PLAY MODE** during playback.

Step Full!

You tried to program 25 or more tracks (steps).

TAPE

No Tab

You cannot record the tape because the tab has been removed from the cassette.

No Tape

There is no tape in the tape deck.

Timer

OFF TIME NG!

The Play Timer or Rec Timer start and end times are set to the same time.

PUSH SELECT!

You tried to set the clock or timer during timer operation.

SET CLOCK!

You tried to select the timer with the clock not set.

SET TIMER!

You tried to select the timer with the timer not set.

Additional Information

Precautions

On operating voltage

Before operating the system, check that the operating voltage of your system is identical with the voltage of your local power supply.

On safety

- The unit is not disconnected from the AC power source (mains) as long as it is connected to the wall outlet, even if the unit itself has been turned off.
- Unplug the system from the wall outlet (mains) if it is not to be used for an extended period of time. To disconnect the power cord (mains lead), pull it out by the plug. Never pull the cord itself.
- Should any solid object or liquid fall into the system, unplug the system and have it checked by qualified personnel before operating it any further.
- AC power cord must be changed only at the qualified service shop.

On placement

- Do not place the system in an inclined position.
- Do not place the system in locations where it is;
 - Extremely hot or cold
 - Dusty or dirty
 - Very humid
 - Subject to vibrations
 - Subject to direct sunlight.
- Use caution when placing the unit or speakers on surfaces that have been specially treated (with wax, oil, polish, etc.) as staining or discoloration of the surface may result.

On heat buildup

- Although the system heats up during operation, this is not a malfunction.
- Place the system in a location with adequate ventilation to prevent heat build-up in the system.
- If you continuously use this system at a high volume, the cabinet temperature of the top, side and bottom rises considerably. To avoid burning yourself, do not touch the cabinet.
- To prevent a malfunction, do not cover the ventilation hole.

On the speaker system

This speaker system is not magnetically shielded and the picture on TV sets may become magnetically distorted. In such a case, turn off the power of the TV set once, and after 15 to 30 minutes turn it on again.

If there seems to be no improvement, locate the speaker system further away from the TV set.

On operation

- If the system is brought directly from a cold to a warm location, or is placed in a very damp room, moisture may condense on the lens inside the CD player. Should this occur, the system will not operate properly. Remove the disc and leave the system turned on for about an hour until the moisture evaporates.
- When you move the system, take out any disc.

If you have any questions or problems concerning your system, please consult your nearest Sony dealer.

Notes on discs

- Before playing, clean the disc with a cleaning cloth. Wipe the disc from the center out.
- Do not use solvents such as benzene, thinner, commercially available cleaners or anti-static spray intended for vinyl LPs.
- Do not expose the disc to direct sunlight or heat sources such as hot air ducts, nor leave it in a car parked in direct sunlight.
- Do not use discs encircled with a protection ring. This may cause a malfunction to the system.
- When using discs that have glue or similar tacky substance on the label side of the disc or that used a special ink when the label was printed, there is a chance that the disc or label may become attached to parts inside this unit. When this occurs, it may not be possible to remove the disc, and may also cause this unit to malfunction. Be sure to check that the label side of the disc is not sticky before using. The following types of disc should not be used:
 - Rental or used discs with attached seals where the glue extends beyond the seal. The perimeter of the seal on the disc is tacky.
 - Discs that have labels printed using a special ink that feels tacky when touched.
- Discs with non-standard shapes (e.g., heart, square, star) cannot be played on this unit. Attempting to do so may damage the unit. Do not use such discs.

Cleaning the cabinet

Clean the cabinet, panel and controls with a soft cloth slightly moistened with mild detergent solution. Do not use any type of abrasive pad, scouring powder or solvent such as thinner, benzene or alcohol.

To save a tape permanently

To prevent a tape from being accidentally recorded over, break off the cassette tab from side A or B as illustrated.

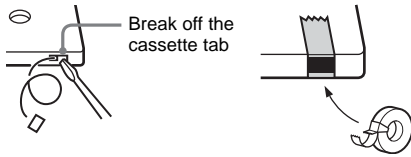

If you later want to reuse the tape for recording, cover the broken tab with adhesive tape.

Before placing a cassette in the tape deck

Take up any slack in the tape. Otherwise, the tape may get entangled in the parts of the tape deck and become damaged.

When using a tape longer than 90 minutes

The tape is very elastic. Do not change the tape operations such as play, stop, and fast-winding frequently. The tape may get entangled in the tape deck.

Cleaning the tape heads

Clean the tape heads after every 10 hours of use. Be sure to clean the tape heads before you start an important recording or after playing an old tape. Use a separately sold dry-type or wet-type cleaning cassette. For details, refer to the instructions of the cleaning cassette.

Demagnetizing the tape heads

Demagnetize the tape heads and the metal parts that have contact with the tape after every 20 to 30 hours of use with a separately sold demagnetizing cassette. For details, refer to the instructions of the demagnetizing cassette.

Specifications

Main unit

Amplifier section

For the U.S.A. model

AUDIO POWER SPECIFICATIONS

CMT-CPX22

POWER OUTPUT AND TOTAL HARMONIC DISTORTION:

With 4-ohm loads, both channels driven, from 120 – 10,000 Hz; rated 100 watts per channel minimum RMS power, with no more than 10% total harmonic distortion from 250 milliwatts to rated output.

Other models:

The following measured at AC 120 – 127/220 – 240 V, 50/60 Hz (Saudi Arabian model only)

The following measured at AC 230 V, 50/60 Hz (European and Russian models only)

The following measured at AC 120/220 – 240 V, 50/60 Hz (except for European, Russian and Saudi Arabian models)

The following measured at AC 220 V, 60 Hz (Korean model only)

CMT-CP555

DIN power output (rated): 55 + 55 watts
(6 ohms at 1 kHz, DIN)

Continuous RMS power output (reference):
75 + 75 watts
(6 ohms at 1 kHz, 10% THD)

CMT-CPX22

DIN power output (rated): 75 + 75 watts
(4 ohms at 1 kHz, DIN)

Continuous RMS power output (reference):
100 + 100 watts
(4 ohms at 1 kHz, 10% THD)

Inputs	
VIDEO/MD IN (phono jacks):	Sensitivity 250/450 mV, impedance 47 kilohms
Outputs	
DIGITAL (OPTICAL) OUT:	Optical Wavelength: 660 nm
PHONES (mini jack):	accepts headphones with an impedance of 8 ohms or more
SPEAKER:	Use only the supplied speakers SS-CP555S (CMT-CP555) SS-CPX22 (CMT-CPX22)

CD player section

System	Compact disc and digital audio system
Laser	Semiconductor laser ($\lambda=770 - 810$ nm) Emission duration: continuous
Frequency response	2 Hz – 20 kHz (± 0.5 dB)

Tape deck section

Recording system	4-track 2-channel stereo
Frequency response	50 – 13,000 Hz (± 3 dB), using Sony TYPE I cassettes
Wow and flutter	$\pm 0.15\%$ W. Peak (IEC) 0.1% W. RMS (NAB) $\pm 0.2\%$ W. Peak (DIN)

Tuner section

FM stereo, FM/AM superheterodyne tuner

FM tuner section

Tuning range	
U.S.A. model:	87.5 – 108.0 MHz (100-kHz step)
Russian model:	65.0 – 74.0 MHz (10-kHz step) (There is no stereo effect) 87.5 – 108.0 MHz (50-kHz step)
Other models:	87.5 – 108.0 MHz (50-kHz step)
Antenna	FM lead antenna
Antenna terminals	75 ohms unbalanced
Intermediate frequency	10.7 MHz

AM tuner section

Tuning range	
Pan-American model:	530 – 1,710 kHz (with the tuning interval set at 10 kHz) 531 – 1,710 kHz (with the tuning interval set at 9 kHz)
European, Russian and Saudi Arabian models:	531 – 1,602 kHz (with the tuning interval set at 9 kHz)
Other models:	531 – 1,602 kHz (with the tuning interval set at 9 kHz) 530 – 1,710 kHz (with the tuning interval set at 10 kHz)
Antenna	AM loop antenna
Antenna terminals	External antenna terminal
Intermediate frequency	450 kHz

Speaker

Front speaker SS-CP555S for CMT-CP555	
Speaker system	2-way, bass-reflex type
Speaker units	
Woofer:	15 cm dia., cone type
Tweeter:	2.5 cm dia., balanced- dome-type
Nominal impedance	6 ohms
Dimensions (w/h/d)	Approx. 173 × 275 × 265 mm
Mass	Approx. 3.0 kg net per speaker

Front speaker SS-CPX22 for CMT-CPX22	
Speaker system	2-way, bass-reflex type
Speaker units	
Woofer:	15 cm dia., cone type
Tweeter:	2.5 cm dia., soft-dome- type
Nominal impedance	4 ohms
Dimensions (w/h/d)	Approx. 173 × 275 × 265 mm
Mass	Approx. 3.9 kg net per speaker

General

Power requirements

U.S.A. model:	120 V AC, 60 Hz
European and Russian models:	230 V AC, 50/60 Hz
Korean model:	220 V AC, 60 Hz
Saudi Arabian model:	120 – 127 V or 220 – 240 V AC, 50/60 Hz Adjustable with voltage selector
Other models:	120 V, 220 – 240 V AC, 50/60 Hz Adjustable with voltage selector

Power consumption

U.S.A. model:	
CMT-CPX22	65 watts
European and Russian models:	
CMT-CP555	110 watts 0.3 watts (in Power Saving mode)
CMT-CPX22	65 watts 0.3 watts (in Power Saving mode)

Other models:

CMT-CP555	115 watts
CMT-CPX22	65 watts

Dimensions (w/h/d) incl. projecting parts and controls

Amplifier/Tuner/Tape/CD section:	
	Approx. 230 × 292 × 355 mm

Mass

Amplifier/Tuner/Tape/CD section:	
CMT-CP555	Approx. 6.5 kg
CMT-CPX22	Approx. 6.1 kg
Supplied accessories	Remote Commander (1) Size AA (R6) batteries (2) AM loop antenna (1) FM lead antenna (1) Speaker pads (8) Speaker cords (CMT-CPX22 only) (2)

Design and specifications are subject to change without notice.

Remote control

ALPHABETICAL ORDER

A - E

ALBUM - **13** (10, 11, 17)
 ALBUM + **11** (10, 11, 17)
 CD **18** (9, 11, 19)
 CLEAR **15** (12)
 CLOCK/TIMER SELECT **2**
 (21, 22)
 CLOCK/TIMER SET **3** (8, 21,
 22)
 DISC SKIP **10** (10, 11)
 DISPLAY **21** (15, 23, 24)
 ENTER **9** (8, 11, 13, 21, 22)
 EQ **14** (19)

F - Z

FM MODE **4** (14)
 FUNCTION **6** (9, 11, 12, 14, 16,
 19)
 PLAY MODE **20** (9, 11, 16, 17,
 18, 22)
 REPEAT **4** (11)
 SLEEP **22** (20)
 TAPE **17** (16)
 TUNER BAND **5** (12, 14)
 TUNER MEMORY **19** (12)
 TUNING MODE **20** (12, 14)
 VOLUME +/- **12** (21)

BUTTON DESCRIPTIONS

I/⏻ (power) **1** (7, 21)
 ◀▶ (rewind/fast forward)
7 (10, 16)
 ▶ (play) **8** (10, 16)
 || (pause) **8** (10, 16)
 ■ (stop) **8** (10, 16)
 ◀▶/▶ (go back/go forward)
16 (8, 10, 17, 19, 21)
 -/+ (tuning) **12** (12)

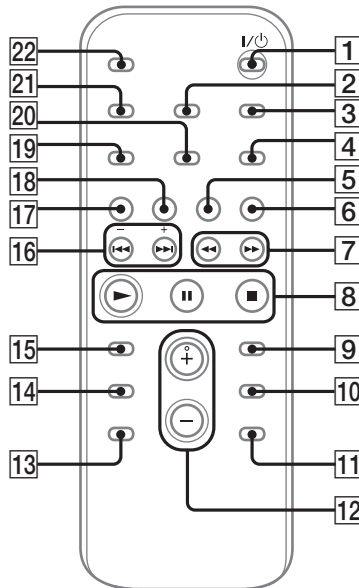

Free Manuals Download Website

<http://myh66.com>

<http://usermanuals.us>

<http://www.somanuals.com>

<http://www.4manuals.cc>

<http://www.manual-lib.com>

<http://www.404manual.com>

<http://www.luxmanual.com>

<http://aubethermostatmanual.com>

Golf course search by state

<http://golfingnear.com>

Email search by domain

<http://emailbydomain.com>

Auto manuals search

<http://auto.somanuals.com>

TV manuals search

<http://tv.somanuals.com>