

Mini Hi-Fi Component System

Operating Instructions

Owner's Record

The model and serial numbers are located on the rear panel. Record the serial number in the space provided below. Refer to them whenever you call upon your Sony dealer regarding this product.

Model No. _____ Serial No. _____



MHC-RXD3 / GRX20

WARNING

To prevent fire or shock hazard, do not expose the unit to rain or moisture.

To avoid electrical shock, do not open the cabinet. Refer servicing to qualified personnel only.

Do not install the appliance in a confined space, such as a bookcase or built-in cabinet.



This appliance is classified as a CLASS 1 LASER product. The CLASS 1 LASER PRODUCT MARKING is located on the rear exterior.

NOTICE FOR THE CUSTOMERS IN THE U.S.A.

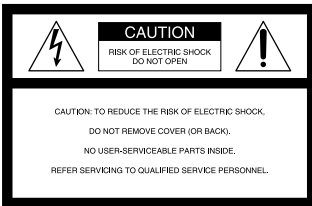

This symbol is intended to alert the user to the presence of uninsulated “dangerous voltage” within the product’s enclosure that may be of sufficient magnitude to constitute a risk of electric shock to persons.



This symbol is intended to alert the user to the presence of important operating and maintenance (servicing) instructions in the literature accompanying the appliance.

CAUTION

The use of optical instruments with this product will increase eye hazard.

INFORMATION

This equipment has been tested and found to comply with the limits for a Class B digital device, pursuant to Part 15 of the FCC Rules. These limits are designed to provide reasonable protection against harmful interference in a residential installation. This equipment generates, uses, and can radiate radio frequency energy and, if not installed and used in accordance with the instructions, may cause harmful interference to radio communications. However, there is no guarantee that interference will not occur in a particular installation. If this equipment does cause harmful interference to radio or television reception, which can be determined by turning the equipment off and on, the user is encouraged to try to correct the interference by one or more of the following measures:

- Reorient or relocate the receiving antenna.
- Increase the separation between the equipment and receiver.
- Connect the equipment into an outlet on a circuit different from that to which the receiver is connected.
- Consult the dealer or an experienced radio/TV technician for help.

CAUTION

You are cautioned that any changes or modifications not expressly approved in this manual could void your authority to operate this equipment.

Note on CATV system installer:

This reminder is provided to call CATV system installer’s attention to Article 820–40 of the NEC that provides guidelines for proper grounding and, in particular, specifies that the cable ground shall be connected to the grounding system of the building, as close to the point of cable entry as practical.

NOTICE FOR THE CUSTOMERS IN CANADA

CAUTION:

TO PREVENT ELECTRIC SHOCK, DO NOT USE THIS POLARIZED AC PLUG WITH AN EXTENSION CORD, RECEPTACLE OR OTHER OUTLET UNLESS THE BLADES CAN BE FULLY INSERTED TO PREVENT BLADE EXPOSURE.

Table of Contents

Getting Started

Step 1: Hooking up the system	4
Step 2: Setting the time	6
Step 3: Presetting radio stations	7
Connecting optional AV components	8
Connecting outdoor antennas	9

Basic Operations

Playing a CD	10
Recording a CD	12
Listening to the radio	13
Recording from the radio	14
Playing a tape	15
Recording from a tape	17

The CD Player

Using the CD display	18
Playing the CD tracks repeatedly	18
Playing the CD tracks in random order	19
Programming the CD tracks	20

The Tape Deck

Recording on a tape manually	22
Recording CDs by specifying the track order	23

Sound Adjustment

Adjusting the sound	25
Selecting the audio emphasis	25

Other Features

Falling asleep to music	26
Waking up to music	27
Timer-recording radio programs	28

Additional Information

Precautions	30
Troubleshooting	31
Specifications	34
Index	back cover

Step 1: Hooking up the system

Do the following procedure **1** to **5** to hook up your system using the supplied cords and accessories.

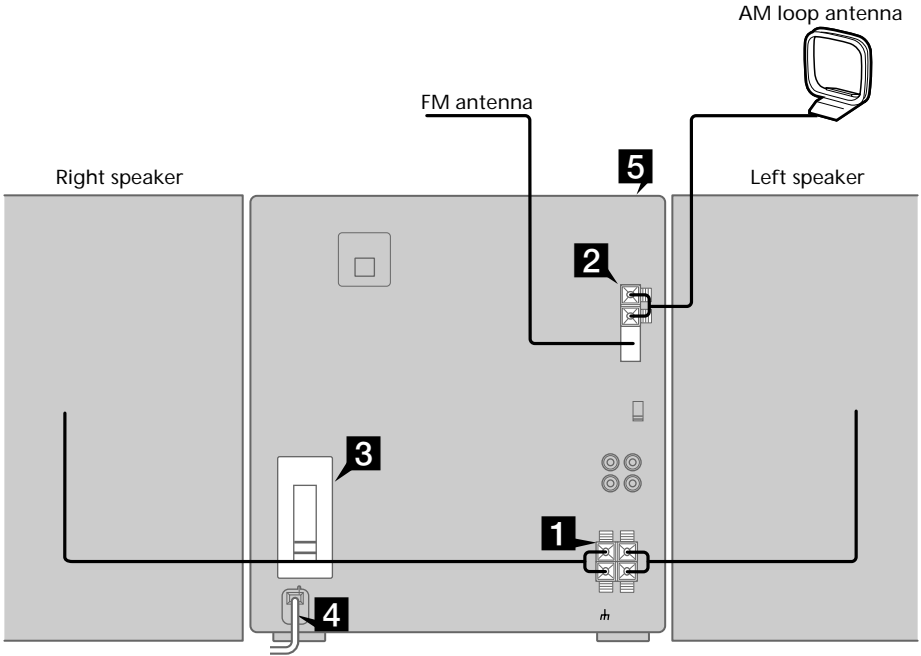

1 Connect the speakers.

Connect the speaker cords to the SPEAKER jacks of the same color. Keep the speaker cords away from the antennas to prevent noise.

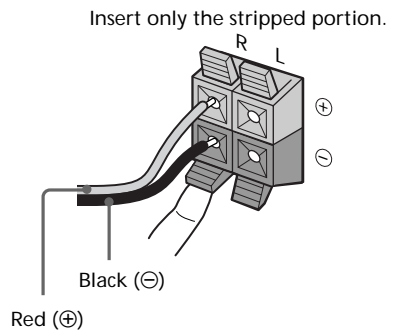

Note

The type of supplied speakers varies according to the model you purchased (see “Specifications” on page 34).

- 2** Connect the FM/AM antennas.
Set up the AM loop antenna, then connect it.

Jack type ①

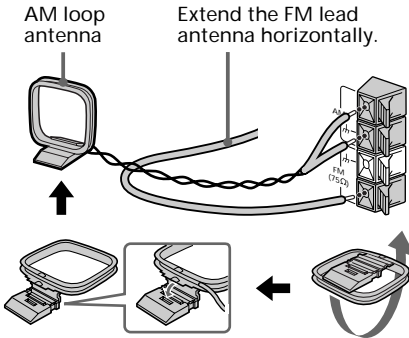

Jack type ②

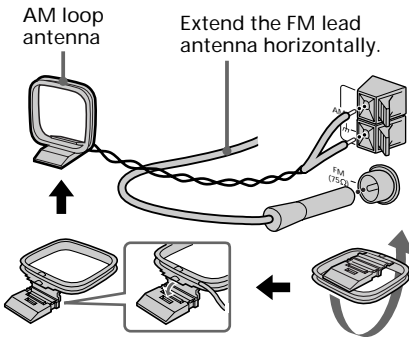

- 3** Set **VOLTAGE SELECTOR** to the position of your local power line voltage (for models with a voltage selector).

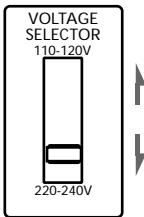

- 4** Connect the power cord to a wall outlet.
The demonstration appears in the display.

If the plug on this unit does not fit your wall outlet, attach the supplied plug adaptor (for Asian model).

- 5** Deactivate the demonstration mode by pressing **DISPLAY/DEMO** when the system is turned off.
The demonstration mode is also deactivated when you set the time.

Inserting two size AAA (R03) batteries into the remote

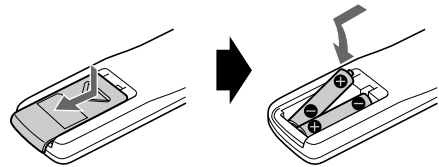

Tip

With normal use, the batteries should last for about six months. When the remote no longer operates the system, replace both batteries with new ones.

Note

If you do not use the remote for a long period of time, remove the batteries to avoid possible damage from battery leakage.

Step 2: Setting the time

You must set the time before using the timer functions.

You can set the time while the system is off. For European models, the clock is on a 24-hour system.

For other models, the clock is on a 12-hour (AM/PM) system.

The 12-hour system model is used for illustration purpose.

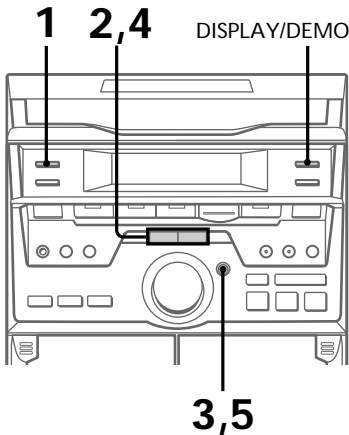

-
- 1 Press **CLOCK/TIMER SET**.
The hour indication flashes.



-
- 2 Press **◀▶** or **▶▶** repeatedly to set the hour.



-
- 3 Press **ENTER/NEXT**.
The minute indication flashes.

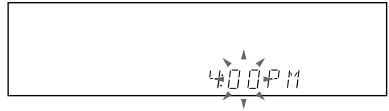

-
- 4 Press **◀▶** or **▶▶** repeatedly to set the minute.

-
- 5 Press **ENTER/NEXT**.
The clock starts working.
-

To change the preset time

You can also change the time while the system is on.

- 1 Press **CLOCK/TIMER SET**.
- 2 Press **◀▶** or **▶▶** repeatedly until "SET CLOCK" appears, then press **ENTER/NEXT**.
- 3 Repeat steps 2 to 5 in "Setting the time".

Tips

- If you've made a mistake, start over from step 1.
- Setting the time deactivates the demonstration mode.

If you want to display the demonstration mode, press **DISPLAY/DEMO** when the system is off.

Step 3: Presetting radio stations

You can preset up to 30 stations, 20 for FM and 10 for AM.

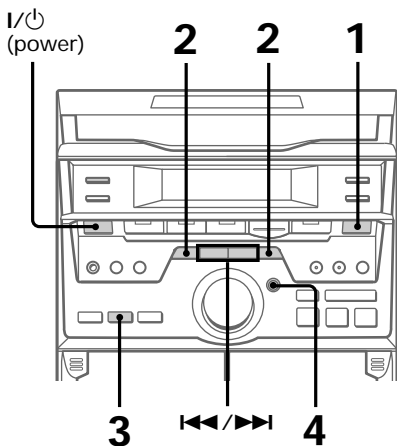

1 Press TUNER/BAND repeatedly until the band you want appears in the display.

Every time you press this button, the band changes as follows:
FM ↔ AM

2 Press and hold - or + until the frequency indication starts to change automatically, then release it.

Scanning stops when the system tunes in a station. "TUNED" and "STEREO" (for a stereo program) appear.

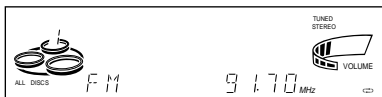

3 Press TUNER MEMORY.
A preset number flashes in the display.

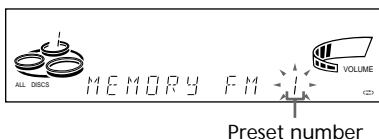

4 Press ENTER/NEXT.
The station is stored.

5 Repeat steps 1 to 4 to store other stations.

To tune in a station with a weak signal

When the desired station is skipped during automatic tuning, press - or + repeatedly in step 2 to tune in the station manually.

To set another station to the exist preset number

Start over from step 1. After step 3, press ◀◀ or ▶▶ repeatedly to select the preset number you want to store the station.

Step 3: Presetting radio stations (continued)

To erase a preset number

- 1 Press and hold TUNER MEMORY until the preset number flashes in the display.
- 2 Press ◀◀ or ▶▶ repeatedly to select the preset number you want to erase.
If you want to erase all preset numbers, select "ALL ERASE".
- 3 Press ENTER/NEXT.

When you erase a preset number, the total number of preset stations decreases by one. You can add a new preset number after the last preset number.

To change the AM tuning interval (for models with the AM TUNING STEP switch on the rear panel)

The AM tuning interval is factory-preset to 9 kHz (10 kHz in some areas). To change the AM tuning interval, turn off the system and set the AM TUNING STEP switch on the rear panel to 10 kHz (or 9 kHz). Then turn the system back on. When you change the interval, all the preset stations will be erased.

Tip

The preset stations are retained for half a day even if you unplug the power cord or if a power failure occurs.

Connecting optional AV components

To enhance your system, you can connect optional components. Refer to the instructions of each component.

Connecting audio components

Select one of the following two connections, depending on the equipment to be connected and method of recording.

Connecting an MD deck for digital recording

You can record from CD into the MD deck digitally by connecting an optical cable (not supplied).

To the DIGITAL IN connector
of the MD deck

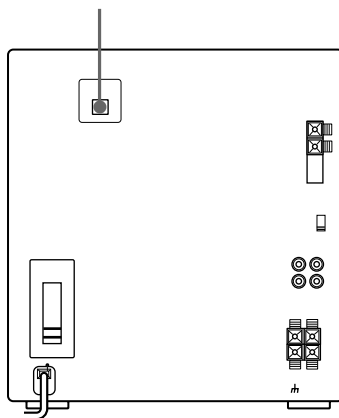

Connecting an MD deck for analog recording

Make sure to match the color of the plugs and the connectors. To listen to the sound of the connected MD deck, press FUNCTION repeatedly until "MD" appears.

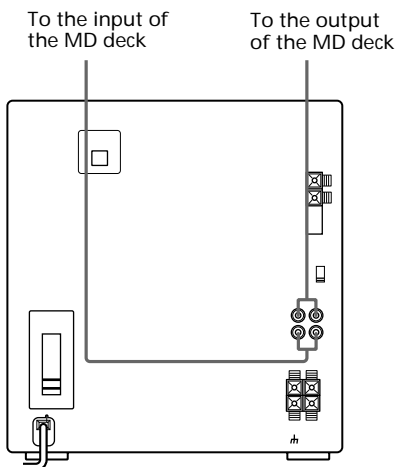

Connecting outdoor antennas

Connect the outdoor antenna to improve the reception.

FM antenna

Connect the optional FM outdoor antenna. You can also use the TV antenna instead.

Jack type ①

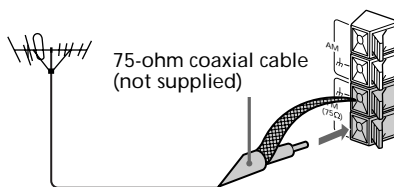

Jack type ②

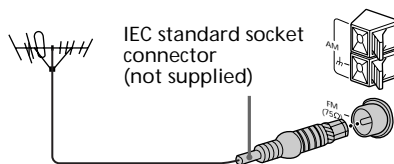

Connecting outdoor antennas (continued)

AM antenna

Connect a 6- to 15- meter (20- to 50- feet) insulated wire to the AM antenna terminal. Leave the supplied AM loop antenna connected.

Jack type A

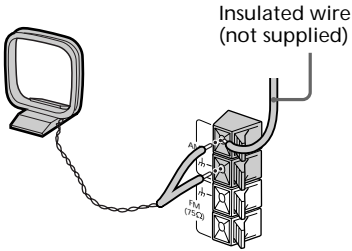

Jack type B

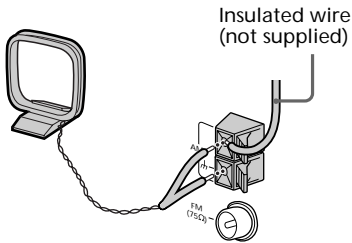

Playing a CD

— Normal play

You can play up to three CDs in a row.

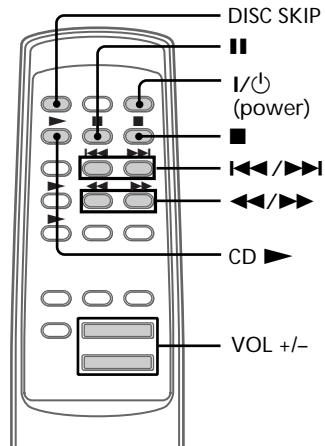
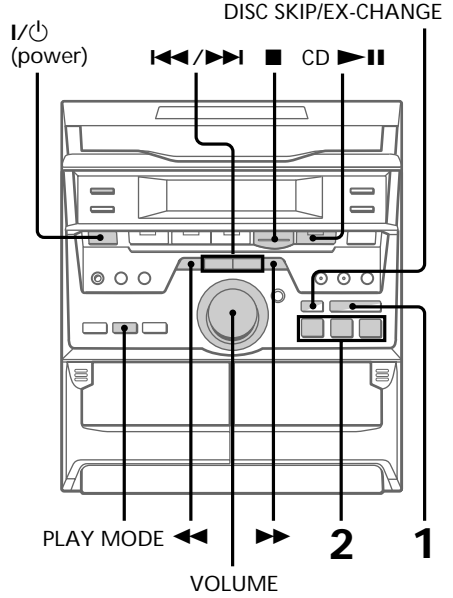

- 1** Press **▲ OPEN/CLOSE** and place up to two CDs on the disc tray. If a disc is not placed properly, it will not be recognized.

With the label side up. When you play a single CD, place it on the inner circle of the tray.



To insert a third disc, press **DISC SKIP/EX-CHANGE** to rotate the disc tray.

- 2** Press one of the **DISC 1 – 3** buttons. The disc tray closes and play starts. If you press **CD ►||** (or **CD ►** on the remote) when the disc tray is closed, play starts from the CD loaded on the disc tray whose number is displayed.

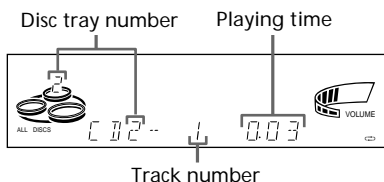

To	Do this
Stop play	Press ■ .
Pause	Press CD ► (or on the remote). Press again to resume play.
Go to the next track or go back to the start of the current track	During play or pause, press ►► (to go forward) or ◄◄ (to go back).
Find a point in a track	Press and hold down ►► or ◄◄ during play and release it at the desired point.
Select a CD in stop mode	Press DISC 1 – 3 or DISC SKIP/EX-CHANGE .
Play only the CD you have selected	Press PLAY MODE repeatedly until "1 DISC" appears.
Play all CDs	Press PLAY MODE repeatedly until "ALL DISCS" appears.
Remove the CD	Press ▲ OPEN/CLOSE .
Exchange other CDs while playing	Press DISC SKIP/EX-CHANGE .
Adjust the volume	Turn VOLUME (or press VOL +/- on the remote).

Tips

- Pressing **CD ►||** when the system is off automatically turns the system on and starts CD playback if there is a CD in the tray (One Touch Play).
- You can switch from another source to the CD player and start playing a CD just by pressing **CD ►||** or **DISC 1 – 3** (Automatic Source Selection).
- If there is no CD in the player, "CD NO DISC" appears in the display.

Recording a CD

— CD Synchro Recording

The CD SYNC button lets you record from a CD to a tape easily. You can use a TYPE I (normal) tape.

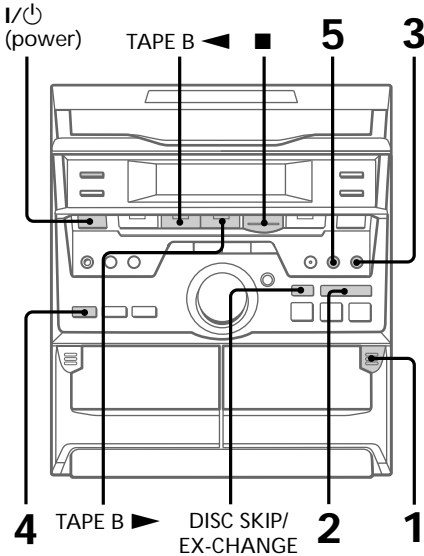

- 1 Press and insert a blank tape into deck B.

With the side you want to record facing forward

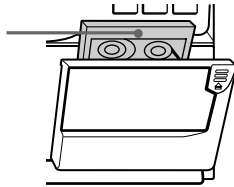

- 2 Press OPEN/CLOSE and place a CD.
Then press again to close the disc tray.
If the disc number you want to record is not displayed, press DISC SKIP/EX-CHANGE repeatedly so that it appears.

With the label side up. When you play a single CD, place it on the inner circle of the tray.



- 3 Press CD SYNC.
Deck B stands by for recording and the CD player stands by for playback. The indicator on TAPE B (for front side) lights up.
- 4 Press DIRECTION repeatedly to select to record on one side.
Select (or RELAY) to record on both sides.
- 5 Press PAUSE.
Recording starts.

To stop recording

Press .

Tips

- If you want to record from the reverse side, press TAPE B to light its indicator after pressing CD SYNC in step 3.
- When you record on both sides, be sure to start from the front side. If you start from the reverse side, recording stops at the end of the reverse side.

Note

You cannot listen to other sources while recording.

Listening to the radio

-- Preset Tuning

Preset radio stations in the tuner's memory first (see "Step 3: Presetting radio stations" on page 7).

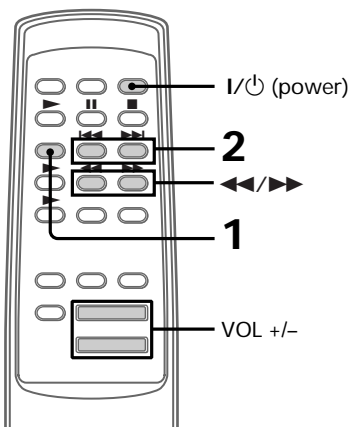
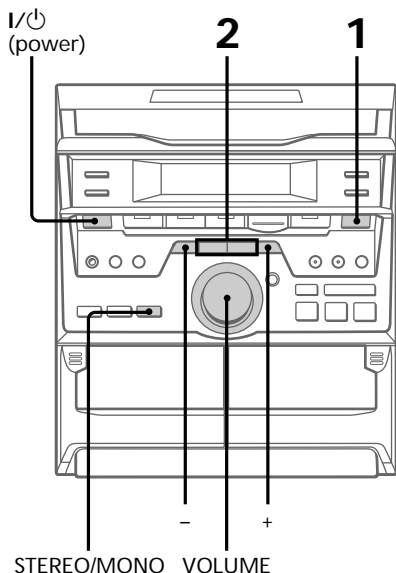

- 1 Press TUNER/BAND repeatedly until the band you want appears in the display.

Every time you press this button, the band changes as follows:
FM ↔ AM

- 2 Press ⏪ or ⏩ repeatedly to tune in the desired preset station. Press ⏪ for lower preset numbers. Press ⏩ for higher preset numbers.

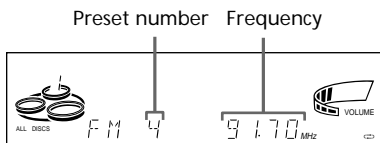

To	Do this
Turn off the radio	Press I/⏻ (power).
Adjust the volume	Turn VOLUME (or press VOL +/- on the remote).

To listen to non-preset radio stations

Automatic tuning

Press and hold - or + (⏪/⏩ on the remote) in step 2 until the frequency indication starts to change, then release it.

Manual tuning

Press - or + (⏪/⏩ on the remote) repeatedly in step 2 to tune in the station.

Tips

- Pressing TUNER/BAND when the system is off automatically turns the system on and tunes in the last received station (One Touch Play).
- You can switch from another source to the radio just by pressing TUNER/BAND (Automatic Source Selection).
- When an FM program is noisy, press STEREO/MONO so that “MONO” appears in the display. There will be no stereo effect, but the reception will improve. Press the button again to restore the stereo effect.
- To improve broadcast reception, reorient the supplied antennas.

Recording from the radio

You can record the radio program on a tape by calling up a preset station. You can use a TYPE I (normal) tape.

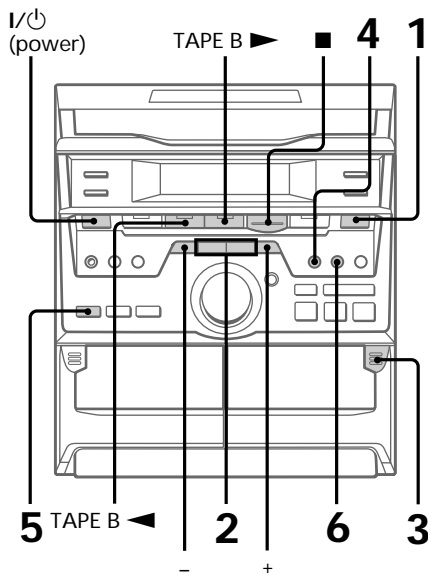

1 Press TUNER/BAND to select the band you want.

2 Press ◀◀ or ▶▶ repeatedly to tune in the desired preset station. Press ◀◀ for lower preset numbers. Press ▶▶ for higher preset numbers.

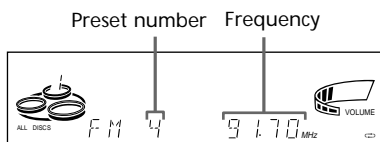

3 Press and insert a blank tape into deck B.

With the side you want to record facing forward

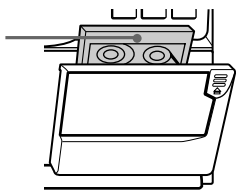

4 Press REC.
Deck B stands by for recording.
The indicator on TAPE B (for front side) lights up.

5 Press DIRECTION repeatedly to select to record on one side.
Select (or RELAY) to record on both sides.

6 Press PAUSE.
Recording starts.

To stop recording

Press .

Tips

- If you want to record from the reverse side, press TAPE B to light its indicator after pressing REC in step 4.
- When you record on both sides, be sure to start from the front side. If you start from the reverse side, recording stops at the end of the reverse side.
- To record non-preset stations, use - and + (/) on the remote) in step 2 to tune in the desired station.
- If noise is heard while recording from the radio, move the respective antenna to reduce the noise.

Playing a tape

You can use a TYPE I (normal) tape. To select either deck A or B, press DECK A or DECK B on the remote.

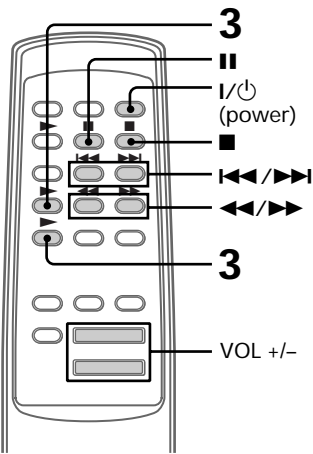
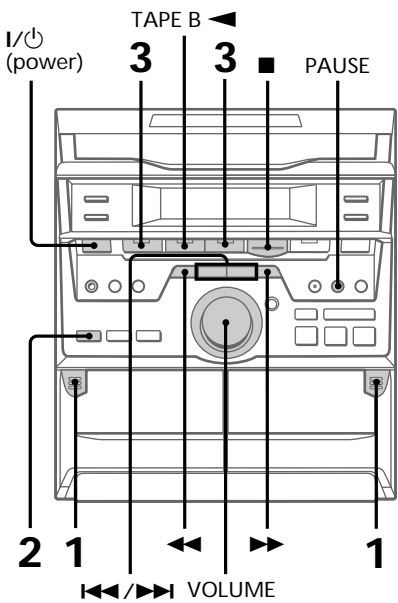

continued

Playing a tape (continued)

- 1 Press $\hat{=}$ and insert a recorded tape in deck A or B.

You can play the reverse side only on deck B.

If you use only deck A, go to step 3.

With the side you want to play facing forward

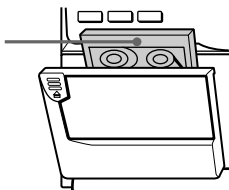

- 2 Press DIRECTION repeatedly to select \rightleftarrows to play one side. Select \leftrightarrow * to play both sides.

To play both decks in succession, select RELAY (relay play).**

- 3 Press TAPE A \blacktriangleright or TAPE B \blacktriangleright (DECK A \blacktriangleright or DECK B \blacktriangleright on the remote).

Press TAPE B \blacktriangleleft (DECK B \blacktriangleright again on the remote) to play the reverse side.

The tape starts playing.

* The deck stops automatically after repeating the sequence five times (Deck B only).

**To enjoy relay play, the tape in deck A must be always on the front side.

If the tape in deck A is on the reverse side, only the tape in deck B repeats playing both sides.

To	Do this
Stop play	Press \blacksquare .
Pause	Press PAUSE (or \mathbb{I} on the remote). Press again to resume play.
Fast-forward	Press $\blacktriangleright\blacktriangleright$.
Rewind	Press $\blacktriangleleft\blacktriangleleft$.
Remove the cassette	Press $\hat{=}$.
Adjust the volume	Turn VOLUME (or press VOL +/- on the remote).

Tips

- Pressing TAPE A \blacktriangleright , TAPE B \blacktriangleright or TAPE B \blacktriangleleft when the system is off automatically turns the system on and starts tape playback if there is a tape in the deck (One Touch Play).
- You can switch from another source to the tape deck just by pressing TAPE A \blacktriangleright , TAPE B \blacktriangleright or TAPE B \blacktriangleleft (Automatic Source Selection).

Searching for the start of the current or the next track (AMS*)

To go forward

Press $\blacktriangleright\blacktriangleright\blacktriangleright$ during play when the \blacktriangleright indicator is lit. "TAPE A (or TAPE B) >>> +1" appears.

Press $\blacktriangleleft\blacktriangleleft\blacktriangleleft$ during play when the \blacktriangleleft indicator is lit. "TAPE B <<< +1" appears.

To go back

Press $\blacktriangleleft\blacktriangleleft\blacktriangleleft$ during play when the \blacktriangleright indicator is lit. "TAPE A (or TAPE B) <<< -1" appears.

Press $\blacktriangleright\blacktriangleright\blacktriangleright$ ** during play when the \blacktriangleleft indicator is lit. "TAPE B >>> -1" appears.

* Automatic Music Sensor

**Deck B only

Note

The AMS function may not operate correctly under the following circumstances:

- When the unrecorded space between songs is less than 4 seconds long.
- If completely different information is recorded on the left and right channels.
- When there are continuous sections of extremely low level or low frequency sound (like those of a baritone sax).
- When the system is placed near a television. (In this case, move the system farther away from the television or turn off the television.)

Recording from a tape

You can use a TYPE I (normal) tape.

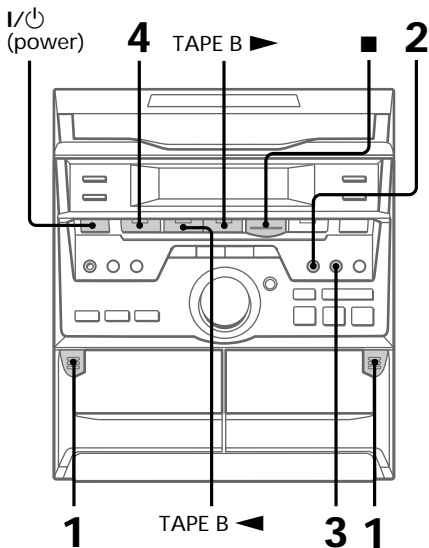

3 Press PAUSE.
Recording starts.

4 Press TAPE A >.

To stop recording

Press ■.

Tip

If you want to record from the reverse side, press TAPE B < to light its indicator after pressing REC in step 2.

1 Press  and insert a recorded tape in deck A and a blank tape in deck B.

With the side you want to play/record facing forward

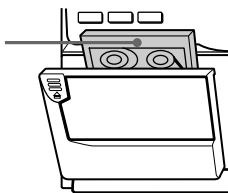

2 Press REC.
Deck B stands by for recording.
The indicator on TAPE B > (for front side) lights up.

Using the CD display

You can check the remaining time of the current track.

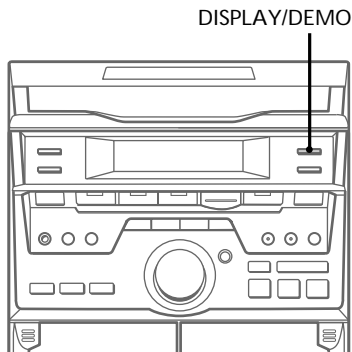

➔ Press DISPLAY/DEMO during playback.

Each time you press the button during normal playback, the display changes as follows:

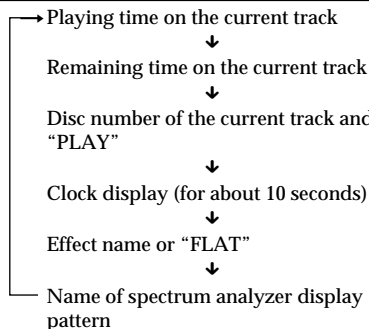

Tip

The total playing time and the number of tracks on a CD are displayed in stop mode.

If you press DISPLAY/DEMO in stop mode, the clock display appears for about 10 seconds, then the display returns to the previous indication.

Playing the CD tracks repeatedly

-- Repeat Play

This function lets you repeat a single CD or all CDs in normal play, Shuffle Play and Program Play.

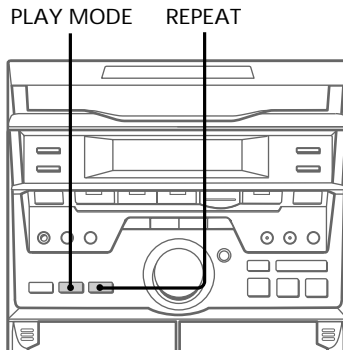

➔ Press REPEAT during playback until "REPEAT" appears in the display.

Repeat Play starts. Do the following procedure to change the repeat mode.

To repeat	Press
All the tracks on the current CD	PLAY MODE repeatedly until "1 DISC" appears in the display.
All the tracks on all CDs	PLAY MODE repeatedly until "ALL DISCS" appears in the display.
Only one track	REPEAT repeatedly until "REPEAT 1" appears in the display while playing the track you want to repeat.

To cancel Repeat Play

Press REPEAT so that "REPEAT" or "REPEAT 1" disappears from the display.

Playing the CD tracks in random order

— Shuffle Play

You can play all the tracks on one CD or all the CDs in random order.

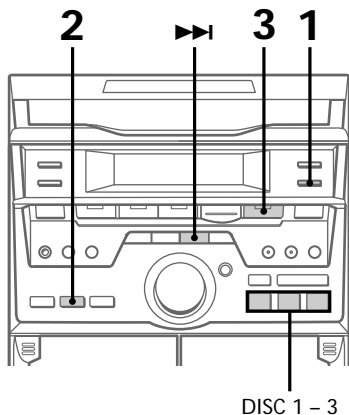

1 Press FUNCTION repeatedly until “CD” appears in the display, then place CDs on the disc tray.

2 Press PLAY MODE repeatedly until “1 DISC SHUFFLE” or “ALL DISCS SHUFFLE” appears in the display. “ALL DISCS” shuffles all the CDs in the player. “1 DISC” shuffles the CD whose disc tray number is displayed.

3 Press CD ►||. “” appears and then all the tracks play in random order.

To cancel Shuffle Play

Press PLAY MODE repeatedly until “SHUFFLE” or “PROGRAM” disappears from the display. The tracks continue playing in their original order.

To select a desired CD

Press DISC 1 - 3.

Tips

- You can start Shuffle Play during normal play by pressing PLAY MODE repeatedly to select “SHUFFLE”.
- To skip a track, press ►|.

Programming the CD tracks

— Program Play

You can make a program of up to 32 tracks from all the CDs in the order you want them to be played.

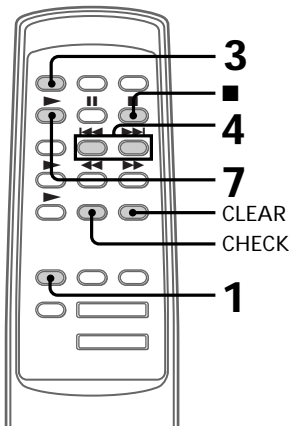
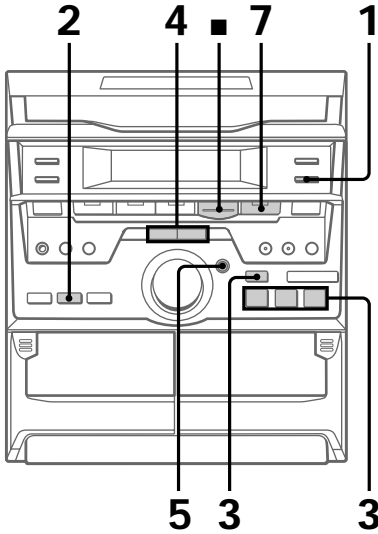

- 1 Press FUNCTION repeatedly until “CD” appears in the display, then place CDs on the disc tray.
- 2 Press PLAY MODE repeatedly until “PROGRAM” appears in the display.
- 3 Press one of the DISC 1 – 3 buttons or DISC SKIP/EX-CHANGE repeatedly to select a CD.
- 4 Press ◀◀ or ▶▶ repeatedly until the desired track appears in the display.

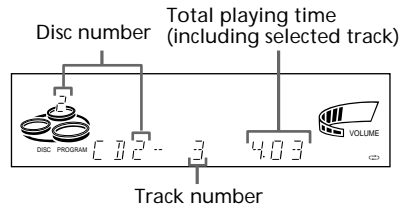

- 5 Press ENTER/NEXT. The track is programmed and the program step number appears.

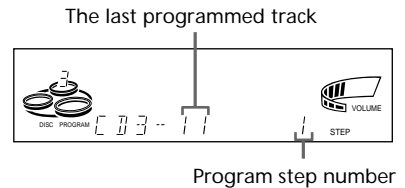

6 To program additional tracks, repeat steps 3 to 5.
Skip step 3 to select tracks from the same disc.

7 Press CD ►|| (or CD ► on the remote).
All the tracks play in the order you selected.

To cancel Program Play

Press PLAY MODE repeatedly until "PROGRAM" or "SHUFFLE" disappears from the display.

To	Press
Check the program	CHECK on the remote repeatedly. After the last track, "CHECK END" appears.
Clear a track from the end	CLEAR on the remote in stop mode.
Clear a specific track	CHECK on the remote repeatedly until the number of the track to be erased appears, then press CLEAR.
Add a track to the program	1 Select a disc tray with a DISC 1 - 3 button. 2 Select the track by pressing ◀◀ or ▶▶ repeatedly. 3 Press ENTER/NEXT.
Clear the entire program	■ once in stop mode or twice while playing.

Tips

- The program you made remains in the CD player even after it has been played back. Press CD ►|| to play the same program again.
- If "--:--" appears instead of the total playing time during programming, this means:
 - you have programmed a track number which exceeds 20, or
 - the total playing time has exceeded 100 minutes.

Recording on a tape manually

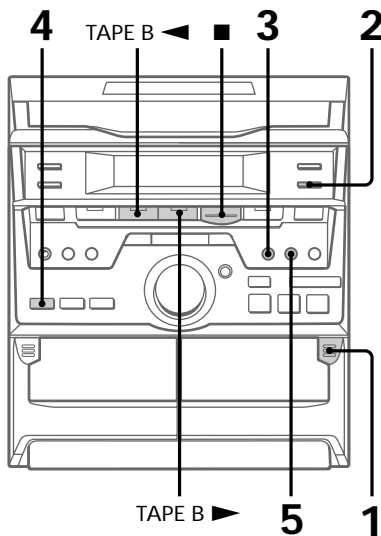

You can record from CD, tape, or radio as you like. For example, you can record just the songs you want or record from the middle of the tape.



1 Press  and insert a blank tape into deck B.

2 Press FUNCTION repeatedly until the source you want to record (e.g., CD) appears.

3 Press REC.
Deck B stands by for recording.
The indicator on TAPE B ▶ (for front side) lights up.

4 Press DIRECTION repeatedly to select  to record on one side.
Select  (or RELAY) to record on both sides.

5 Press PAUSE.
Recording starts.

6 Start playing the source to be recorded.

To	Press
Stop recording	
Pause recording	PAUSE.

Tip

If you want to record from the reverse side, press TAPE B ◀ to light its indicator after pressing REC in step 3.

Recording CDs by specifying the track order

— Program Edit

You can record tracks from all the CDs in the order you want. When programming, make sure the playing times for each side do not exceed the length of one side of the tape.

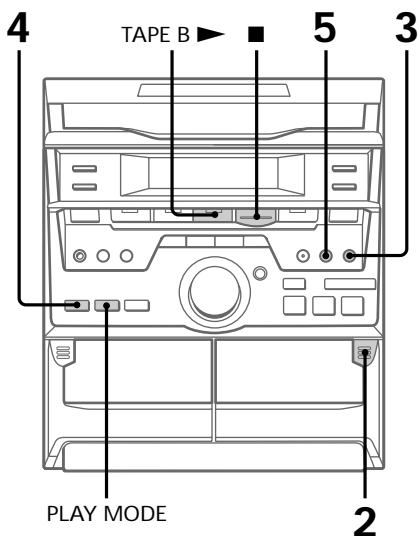

- 1 Follow steps 1 to 6 in “Programming the CD tracks” (see page 20).
- 2 Press and insert a blank tape into deck B.
- 3 Press CD SYNC.
Deck B stands by for recording and the CD player stands by for playback.
The indicator on TAPE B (for front side) lights up.
- 4 Press DIRECTION repeatedly to select to record on one side.
Select (or RELAY) to record on both sides.
- 5 Press PAUSE.
Recording starts.

To stop recording

Press .

To cancel Program Edit

Press PLAY MODE repeatedly until “PROGRAM” or “SHUFFLE” disappears from the display.

Recording CDs by specifying the track order (continued)

Selecting tape length automatically

— Tape Select Edit

You can check the most suitable tape length for recording a CD. Note that you cannot use Tape Select Edit for discs containing over 20 tracks.

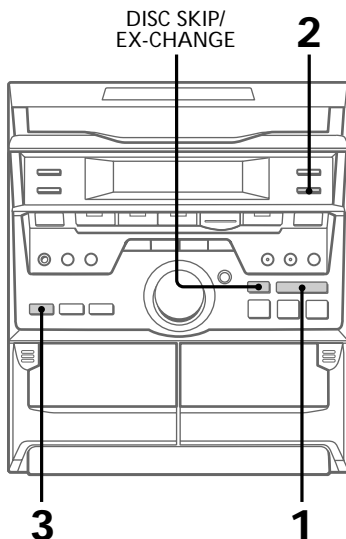

- 1** Place a CD on the disc tray.
If the disc number you want to record is not displayed, press DISC SKIP/EX-CHANGE repeatedly so that it appears.

- 2** Press FUNCTION repeatedly until “CD” appears in the display.

- 3** Press EDIT once so that “EDIT” flashes.

The required tape length for the currently selected CD appears, followed by the total playing time for sides A and B respectively.

Note

You cannot use this function after programming. In order to use this function, you must first erase the program (see “Clear the entire program” in the table on page 21).

Adjusting the sound

You can reinforce the bass and listen with headphones.

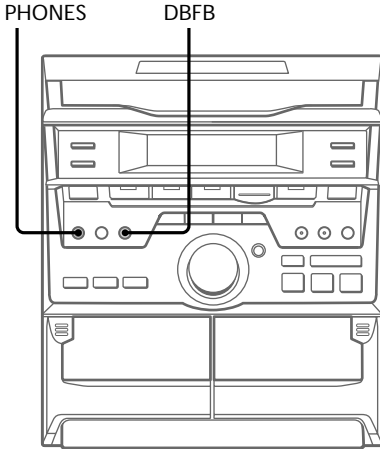

To reinforce bass (DBFB)

Press DBFB*.

"DBFB  " appears in the display.

To cancel DBFB, press DBFB so that "DBFB  " disappears from the display.

* DBFB = Dynamic Bass Feedback

To listen through the headphones

Connect the headphones to PHONES jack. No sound will come from the speakers.

Selecting the audio emphasis

The audio emphasis menu lets you select the sound characteristic according to the sound you are listening to.

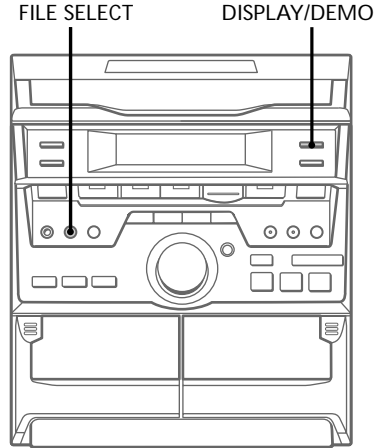

➔ Press FILE SELECT repeatedly until the effect (ROCK, POP or DANCE) you desire appears in the display.

To cancel the effect

Press FILE SELECT repeatedly until "FLAT" appears in the display.

Selecting the audio emphasis (continued)

To change the spectrum analyzer display

Press DISPLAY/DEMO repeatedly to select one of the displays below.

Pattern ①



(Changes with music)

Pattern ②



Note

The spectrum analyzer display changes each time you cycle through the information display (i.e., function → clock → effect).

Falling asleep to music

— Sleep Timer

You can let the system turn off at the preset time, so you can sleep to the music. You can preset the time to be turned off by 10 minutes.

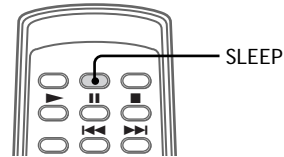

➔ Press SLEEP.

Every time you press the button, the minute display (the turn-off time) changes as follows:

AUTO → 90min → 80min → 70min
→ ... → 10min → OFF → AUTO ...

When you choose “AUTO”

The system turns off when the current CD or tape finishes playback (for up to 100 minutes).

To check the remaining time

Press SLEEP once.

To change the time to turn off

Select the time you want by pressing SLEEP.

To cancel the Sleep Timer function

Press SLEEP repeatedly until “OFF” appears.

Waking up to music

— Daily Timer

You can wake up to music at a preset time every day. Make sure you have set the clock (see “Step 2: Setting the time” on page 6). The 12-hour system model is used for illustration purpose.

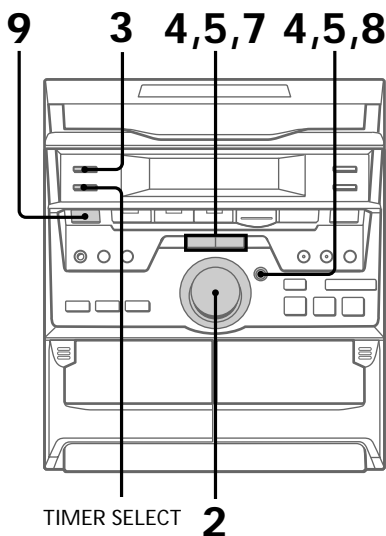

1 Prepare the music source you want to play.

- CD: Place a CD. To start from a specific track, make a program (see “Programming the CD tracks” on page 20).
- Tape: Insert a tape with the side you want to play facing forward.
- Radio: Tune in the preset station you want (see “Step 3: Presetting radio stations” on page 7).

2 Turn VOLUME to adjust the volume.

3 Press CLOCK/TIMER SET. “SET (DAILY)” appears.



4 Press ◀◀ or ▶▶ to select DAILY 1 or 2, then press ENTER/NEXT. “ON” appears and the hour digits flash in the display.



5 Set the time to start playback. Press ◀◀ or ▶▶ repeatedly to set the hour, then press ENTER/NEXT. The minute indication starts flashing.

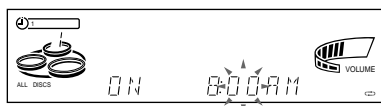

Press ◀◀ or ▶▶ repeatedly to set the minute, then press ENTER/NEXT. “OFF” appears and the hour indication flashes again.

6 Set the time to stop playback following the above procedure.

- 7** Press ◀◀ or ▶▶ repeatedly until the music source you want appears.

The indications change as follows:

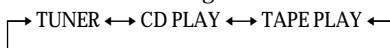

- 8** Press ENTER/NEXT.

The type of timer (“DAILY1” or “DAILY2”) appears, followed by the start time, the stop time and the music source, then the original display appears.

- 9** Turn off the system.

To check the setting

Press TIMER SELECT and press ◀◀ or ▶▶ to select the respective mode (“DAILY1” or “DAILY2”), then press ENTER/NEXT.

To change the setting, start over from step 1.

To cancel the timer operation

Press TIMER SELECT and press ◀◀ or ▶▶ to select “TIMER OFF”, then press ENTER/NEXT.

Tip

The system turns on 15 seconds before the preset time.

Notes

- You cannot set the timer if the timer on and off times are the same.
- When you set the Sleep Timer, the Daily Timer will not turn on the system until the Sleep Timer turns it off.
- You cannot activate the Daily Timer and Timer-recording at the same time.

Timer-recording radio programs

To timer-record, you must preset the radio station (see “Step 3: Presetting radio stations” on page 7) and set the clock (see “Step 2: Setting the time” on page 6) beforehand.

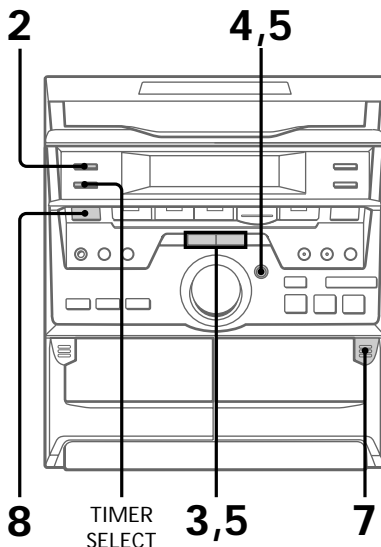

- 1** Tune in the preset radio station (see “Listening to the radio” on page 13).

- 2** Press CLOCK/TIMER SET.
“SET (DAILY1)” appears.

- 3** Press ◀◀ or ▶▶ until “SET REC” appears.



4 Press ENTER/NEXT.

“ON” appears and the hour digits flash in the display.

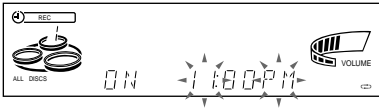

5 Set the time to start recording.

Press ◀ or ▶ repeatedly to set the hour, then press ENTER/NEXT.

The minute indication starts flashing.

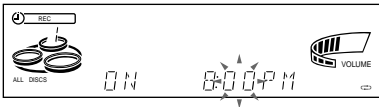

Press ◀ or ▶ repeatedly to set the minute, then press ENTER/NEXT.

“OFF” appears and the hour indication flashes again.

6 Set the time to stop recording following the above procedure.

The type of timer (“REC”) appears, followed by the start time, the stop time and the preset station number, then the original display appears.

7 Press and insert a blank tape into deck B.

8 Turn off the system.

When the recording starts, the volume level is set to the minimum.

To check the setting

Press TIMER SELECT and press ◀ or ▶ to select “TUNER REC”, then press ENTER/NEXT.

To change the setting, start over from step 1.

To cancel the timer operation

Press TIMER SELECT and press ◀ or ▶ to select “TIMER OFF”, then press ENTER/NEXT.

Notes

- If the system is on at the preset time, the recording will not be made.
- You cannot set the timer if the timer on and off times are the same.
- When you set the Sleep Timer, the Timer-recording will not turn on the system until the Sleep Timer turns it off.
- You cannot activate the Timer-recording and Daily Timer at the same time.

Precautions

On operating voltage

Before operating the system, check that the operating voltage of your system is identical with the voltage of your local power supply.

On safety

- The system is not disconnected from the AC power source (mains) as long as it is connected to the wall outlet, even if the system itself has been turned off.
- Unplug the system from the wall outlet (mains) if it is not to be used for an extended period of time. To disconnect the cord (mains lead), pull it out by the plug. Never pull the cord itself.
- Should any solid object or liquid fall into the system, unplug the system and have it checked by qualified personnel before operating it any further.
- The AC power cord must be changed only at the qualified service shop.

On placement

- Place the system in a location with adequate ventilation to prevent heat build-up in the system.
- Do not place the system in an inclined position.
- Do not place the system in locations where it is;
 - Extremely hot or cold
 - Dusty or dirty
 - Very humid
 - Vibrating
 - Subject to direct sunlight

On operation

- If the system is brought directly from a cold to a warm location, or is placed in a very damp room, moisture may condense on the lens inside the CD player. Should this occur, the system will not operate properly. Remove the CD and leave the system turned on for about an hour until the moisture evaporates.
- When you move the system, take out any discs.

If you have any questions or problems concerning your system, please consult your nearest Sony dealer.

Notes on CDs

- Before playing, clean the CD with a cleaning cloth. Wipe the CD from the center out.
- Do not use solvents such as benzene, thinner, commercially available cleaners or anti-static spray intended for vinyl LPs.
- Do not expose the CD to direct sunlight or heat sources such as hot air ducts, nor leave it in a car parked in direct sunlight.

Cleaning the cabinet

Use a soft cloth slightly moistened with mild detergent solution.

To save a tape permanently

To prevent a tape from being accidentally recorded over, break off the cassette tab from side A or B as illustrated.

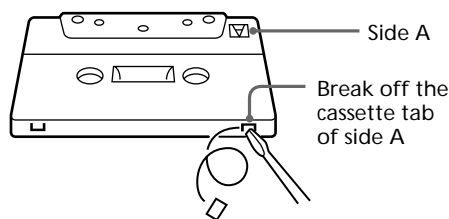
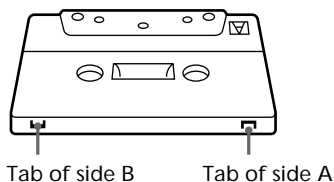

If you later want to reuse the tape for recording, cover the broken tab with adhesive tape.

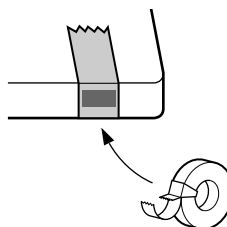

Before placing a cassette in the tape deck

Take up any slack in the tape. Otherwise the tape may get entangled in the parts of the tape deck and become damaged.

When using a tape longer than 90 minutes

The tape is very elastic. Do not change the tape operations such as play, stop, and fast-winding etc. frequently. The tape may get entangled in the tape deck.

Cleaning the tape heads

Clean the tape heads after every 10 hours of use. When the tape heads become dirty

- the sound is distorted
- there is a decrease in sound level
- the sound drops out
- the tape does not erase completely
- the tape does not record.

Make sure to clean the tape heads before you start an important recording or after playing an old tape. Use separately sold dry-type or wet-type cleaning cassette. For details, refer to the instructions of the cleaning cassette.

Demagnetizing the tape heads

Demagnetize the tape heads and the metal parts that have contact with the tape every 20 to 30 hours of use with a separately sold demagnetizing cassette. For details, refer to the instructions of the demagnetizing cassette.

Troubleshooting

If you run into any problem using this system, use the following check list. First, check that the power cord is connected firmly and the speakers are connected correctly and firmly. Should any problem persist, consult your nearest Sony dealer.

General

The display starts flashing as soon as you plug in the power cord even though you haven't turned on the system (demonstration mode).

- Press DISPLAY/DEMO when the system is turned off.

The demonstration mode appears automatically the first time you plug in the power cord. If there is a power outage lasting longer than half a day, redo the following:

- Clock setting (see "Step 2: Setting the time" on page 6)
- Preset stations (see "Step 3: Presetting radio stations" on page 7)
- Timer settings (see "Waking up to music" on page 27 and "Timer-recording radio programs" on page 28)

There is no sound.

- Turn VOLUME clockwise.
- The headphones are connected.
- Insert only the stripped portion of the speaker cord into the SPEAKER jack. Inserting the vinyl portion of the speaker cord will obstruct the speaker connections.

Troubleshooting (continued)

There is severe hum or noise.

- A TV or VCR is placed too close to the system. Move the system away from the TV or VCR.
-

"0:00" (or "12:00AM") flashes in the display.

- A power failure occurred. Set the clock and timer settings again.
-

The timer does not function.

- Set the clock correctly.
-

"DAILY1", "DAILY2" and "REC" do not appear when you press the TIMER SELECT button.

- Set the timer correctly.
 - Set the clock.
-

The remote does not function.

- There is an obstacle between the remote and the system.
 - The remote is not pointing in the direction of the system's sensor.
 - The batteries have run down. Replace the batteries.
-

There is acoustic feedback.

- Decrease the volume level.
-

The color irregularity on a TV screen persists.

- Place the speakers farther away from the TV set.
-

Speakers

Sound comes from one channel or unbalanced left and right volume.

- Check the speaker connection and speaker placement.
-

CD Player

The CD tray does not close.

- The CD is not placed properly.
-

The CD will not play.

- The CD is not lying flat in the disc tray.
 - The CD is dirty.
 - The CD is inserted label side down.
 - Moisture condensation has built up. Remove the CD and leave the system turned on for about an hour until the moisture evaporates.
-

Play does not start from the first track.

- The player is in Program or Shuffle Play mode. Press PLAY MODE repeatedly until "PROGRAM" or "SHUFFLE" disappears.
-

"OVER" is displayed.

- You have reached the end of the CD. Press and hold ◀◀ to return.
-

Tape Deck

The tape does not record.

- No tape in the cassette holder.
- The tab has been removed from the cassette (see “To save a tape permanently” on page 30).
- The tape has reeled to the end.

The tape does not record nor play or there is a decrease in sound level.

- The heads are dirty. Clean them (see “Cleaning the tape heads” on page 31).
- The record/playback heads are magnetized. Demagnetize them (see “Demagnetizing the tape heads” on page 31).

The tape does not erase completely.

- The record/playback heads are magnetized. Demagnetize them (see “Demagnetizing the tape heads” on page 31).

There is excessive wow or flutter, or the sound drops out.

- The capstans or pinch rollers are dirty. Clean them (see “Cleaning the tape heads” on page 31).

Noise increases or the high frequencies are erased.

- The record/playback heads are magnetized. Demagnetize them (see “Demagnetizing the tape heads” on page 31).
-

Tuner

Severe hum or noise (“TUNED” or “STEREO” flashes in the display).

- Adjust the antenna.
- The signal strength is too weak. Connect the external antenna.

A stereo FM program cannot be received in stereo.

- Press STEREO/MONO so that “STEREO” appears.
-

If other troubles not described above occur, reset the system as follows:

- 1 Unplug the power cord.
- 2 Plug the power cord back in.

The system is reset to the factory settings. All the settings you made, such as the preset stations, clock, and timer are cleared. You should set them again.

Specifications

AUDIO POWER SPECIFICATIONS: (U.S.A. model only)

POWER OUTPUT AND TOTAL HARMONIC DISTORTION:

with 6 ohm loads both channels driven, from
70 – 20,000 Hz; rated 50 watts per channel
minimum RMS power, with no more than
0.9% total harmonic distortion from
250 milliwatts to rated output.

Amplifier section

North American model

Continuous RMS power output

60 watts + 60 watts
(6 ohms at 1 kHz,
10% THD)

European model

DIN power output (Rated)

40 watts + 40 watts
(6 ohms at 1 kHz, DIN)

Continuous RMS power output (Reference)

50 watts + 50 watts
(6 ohms at 1 kHz,
10% THD)

Music power output (Reference)

100 watts + 100 watts
(6 ohms at 1 kHz,
10% THD)

Other models

The following measured at AC 110, 220 V 60 Hz;

DIN power output (Rated)

45 watts + 45 watts
(6 ohms at 1 kHz, DIN)

Continuous RMS power output (Reference)

50 watts + 50 watts
(6 ohms at 1 kHz,
10% THD)

The following measured at AC 120, 240 V 60 Hz;

DIN power output (Rated)

50 watts + 50 watts
(6 ohms at 1 kHz, DIN)

Continuous RMS power output (Reference)

60 watts + 60 watts
(6 ohms at 1 kHz,
10% THD)

Inputs

MD IN (phono jacks): voltage 450 mV,
impedance 47 kilohms

Outputs

MD OUT (phono jacks):
voltage 250 mV
impedance 1 kilohm

PHONES (stereo phone jack):
accepts headphones of
8 ohms or more.

SPEAKER:
accepts impedance of 6 to
16 ohms

CD player section

System Compact disc and digital
audio system

Laser Semiconductor laser
($\lambda = 780$ nm)

Laser output Emission duration:
continuous

Max. 44.6 μ W*

* This output is the value
measured at a distance of
200 mm from the
objective lens surface on
the Optical Pick-up Block
with 7 mm aperture.

Frequency response 20 Hz – 20 kHz (± 0.5 dB)

Wavelength 780 – 790 nm

DIGITAL OUT (OPTICAL)

(Square optical connector jack, rear panel)

Wavelength 600 nm

Output Level –18 dBm

Tape deck section

Recording system 4-track 2-channel stereo

Frequency response 40 – 13,000 Hz (± 3 dB),
using Sony TYPE I
cassette

Wow and flutter $\pm 0.15\%$ W.Peak (IEC)

0.1% W.RMS (NAB)

$\pm 0.2\%$ W.Peak (DIN)

Tuner section

FM stereo, FM/AM superheterodyne tuner

FM tuner section

Tuning range 87.5 – 108.0 MHz
Antenna FM lead antenna
Antenna terminals 75 ohm unbalanced
Intermediate frequency 10.7 MHz

AM tuner section

Tuning range 531 – 1,602 kHz
(with AM tuning interval set at 9 kHz)
530 – 1,710 kHz
(with AM tuning interval set at 10 kHz)
Antenna AM loop antenna
Antenna terminals External antenna terminal
Intermediate frequency 450 kHz

Speaker

North American model

Speaker system 2-way, bass-reflex type
Speaker units
Woofers: 13 cm, cone type
Tweeters: 5 cm, cone type
Nominal impedance 6 ohms
Dimensions (w/h/d) Approx.
220 x 320 x 221 mm
(8³/₄ x 12⁵/₈ x 8³/₄ in)
Mass Approx. 3.3 kg (7 lb 4 oz.)
net per speaker

European model

Speaker system 2-way, bass-reflex type
Speaker units
Woofers: 13 cm, cone type
Tweeters: 5 cm, cone type
Nominal impedance 6 ohms
Dimensions (w/h/d) Approx.
220 x 320 x 243 mm
(8³/₄ x 12⁵/₈ x 9⁵/₈ in)
Mass Approx. 3.5 kg (7 lb
11 oz.) net per speaker

Other models

Speaker system 2-way, bass-reflex type
Speaker units
Woofers: 13 cm, cone type
Tweeters: 5 cm, cone type
Nominal impedance 6 ohms
Dimensions (w/h/d) Approx.
220 x 320 x 243 mm
(8³/₄ x 12⁵/₈ x 9⁵/₈ in)
Mass Approx. 3.5kg (7 lb
11 oz.) net per speaker

General

Power requirements

European model: 230 V AC, 50/60 Hz
North American model:
120 V AC, 60 Hz
Mexican model: 120 V AC, 50/60 Hz
Australian model: 240 V AC, 50/60 Hz
Other models: 110 – 120 V or 220 – 240 V
AC,
50/60 Hz (adjustable
with voltage selector)

Power consumption

European and North American models:
105 watts
Other models: 115 watts

Dimensions (w/h/d) incl. projecting parts and controls
Approx.
220 x 320 x 400 mm
(11¹/₈ x 12⁵/₈ x
15³/₄ in)

Mass

North American model:
Approx. 9 kg
(19 lb 13 oz.)

Other models:
Approx. 9.2 kg
(20 lb 5 oz.)

Supplied accessories: AM loop antenna (1)
FM lead antenna (1)
Remote (1)
Plug adaptor (for Asian
model) (1)

Design and specifications are subject to change
without notice.

Index

A

- Adjusting
 - the sound 25
 - the volume 11, 13, 16
- Antennas 5, 9
- Automatic Source Selection 11, 14, 16

B

- Batteries 5

C

- CD player 10, 12, 18
- CD Synchro Recording 12
- Clock setting 6
- Connecting. *See* Hooking up

D

- Daily Timer 27
- Display 6, 7, 11, 13, 18, 26

E, F, G

- Edit 23, 24

H, I, J, K, L, M

- Hooking up
 - optional components 8
 - the antennas 5, 9
 - the power 5
 - the system 4

N

- Normal Play 10

O

- One Touch Play 11, 14, 16

P, Q

- Playing
 - a CD 10
 - a preset radio station 13
 - a tape 15
 - tracks in random order (Shuffle Play) 19
 - tracks in the desired order (Program Play) 20
 - tracks repeatedly (Repeat Play) 18
- Precautions 30
- Presetting radio stations 7
- Preset tuning 13
- Program Edit 23
- Program Play 20
- Protecting recordings 30

R

- Radio stations
 - presetting 7
 - tuning in 13
- Recording
 - a CD 12
 - a radio program 14
 - a tape 17
 - CD by specifying the track order 23
 - selecting tape length automatically 24
 - timer recording 28
- Repeat Play 18
- Resetting the system 33

S

- Saving recordings 30
- Selecting the audio emphasis 25
- Setting the time 6
- Shuffle Play 19
- Sleep Timer 26
- Sound adjustment 25
- Speakers 4

T, U, V, W, X, Y, Z

- Tape Select Edit 24
- Timer
 - falling asleep to music 26
 - timer recording 28
 - waking up to music 27
- Troubleshooting 31
- Tuner 13, 14
- Tuning interval 8, 35

Free Manuals Download Website

<http://myh66.com>

<http://usermanuals.us>

<http://www.somanuals.com>

<http://www.4manuals.cc>

<http://www.manual-lib.com>

<http://www.404manual.com>

<http://www.luxmanual.com>

<http://aubethermostatmanual.com>

Golf course search by state

<http://golfingnear.com>

Email search by domain

<http://emailbydomain.com>

Auto manuals search

<http://auto.somanuals.com>

TV manuals search

<http://tv.somanuals.com>