

ELECTROMAGNETIC FLOWMETER DETECTOR

MODEL LF414

INSTRUCTION MANUAL

TOSHIBA CORPORATION**NOTES**

Before using the equipment, please read this manual carefully and understand the contents, and then use the equipment correctly.

- **NEVER attempt to operate the equipment in any ways that are not described in this instruction manual.**
- **After reading this manual, store it with care in a place where it can be referred to whenever needed.**
- **Please be sure that this manual is delivered to the personnel who will use this product.**

NOTICE

We thank you very much for your purchase of our LF414 series electromagnetic flowmeter detector.

Integral type LF414/LF600F, LF414/LF610F, LF414/LF620F

Separate type detector LF414

This instruction manual describes the notes on using an electromagnetic flowmeter detector, installation, configuration and maintenance. It is intended for the personnel in charge of installation, operation and maintenance.

To use this product properly and safely, read this manual (6F8A0870) carefully before using this product. After reading this manual, store it in a place where it can be referred to whenever needed. This manual uses the following markers to identify the integral type or separate type when it describes items specific to the integrated type or separate type. Items without this marker are common items to the integral type and separate type.

Integral type LF414/LF600F, LF414/LF610F, LF414/LF620F: Integral

Separate type detector LF414: Separate

Toshiba LF414 electromagnetic flowmeter detectors can be used in combination with various types of electromagnetic flowmeter converters (LF600F, LF610F, LF620F, LF602F, LF612F, LF622F).

For the notes on usage, connecting, wiring, installation, configuration and maintenance of the combined converter, check the model number of the combined converter and read the instruction manual of the relevant converter.

About Safety Precautions

Read the **Safety Precautions** described at the front carefully and understand the contents before using this product.

The “**Safely symbols**” used in the “**Safety Precautions**” are shown in a location such as in the margin to the left of the corresponding commentary in the main text.

NOTES

- 1. The reproduction of the contents of this Manual in any form, whether wholly or in part, is not permitted without explicit prior consent and approval.**
- 2. The information contained in this Manual is subject to change or review without prior notice.**
- 3. Be sure to follow all safety, operating and handling precautions described in this Manual and the regulations in force in the country in which this product is to be used.**

7th Edition May, 2011



First Edition September, 2005

SAFETY PRECAUTIONS

Safety signs and labels affixed to the product and/or described in this manual give important information for using the product safely. They help prevent damage to property and obviate hazards for persons using the product. Make yourself familiar with signal words and symbols used for safety signs and labels. Then read the safety precautions that follow to prevent an accident involving personal injury, death or damage to property.



Explanation of signal words

The signal word or words are used to designate a degree or level of hazard seriousness. The signal words used for the product described in this manual are WARNING and CAUTION.

 WARNING	Indicates a potentially hazardous situation which, if not avoided, could result in death or serious injury.
 CAUTION	Indicates a potentially hazardous situation which, if not avoided, may result in minor to moderate injuries or in property damage.







Safety symbols

The following symbols are used in safety signs and labels affixed to a product and/or in the manual for giving safety instructions.

	Indicates an action that is prohibited. Simply DON'T do this action. The prohibited action is indicated by a picture or text inside or next to the circle
	Indicates an action that is mandatory. DO this action. The mandatory action is indicated by a picture or text inside or next to the circle.
	Indicates a potential hazard. The potentially hazardous situation is indicated by a picture or text inside or next to the triangle.











SAFETY PRECAUTIONS

Safety Precautions for Installation and Wiring

 WARNING	
<p>■ Do not disconnect while circuit is live unless location is known to be nonhazardous.</p> <p> DON'T</p>	<p>Live part of electric circuit or a high temperature department can cause explosion.</p>
<p>■ Do not modify or disassemble the enclosure.</p> <p> DON'T</p>	<p>Strength degradation and defects of enclosure can cause explosion.</p>
<p>■ Do not use parts of other products.</p> <p> DON'T</p>	<p>Protective performance degradation for hazardous location can cause explosion.</p>
<p>■ Do not touch live circuits until assembly of all components is not over.</p> <p> DON'T</p>	<p>Protective performance degradation for hazardous location can cause explosion.</p>
<p>■ Install per the National Electrical Code for the US (NEC, ANSI/NFPA 70) and the Canadian Electrical code for Canada (CEC, CAN/CSA-C22.1) and the drawing 3S8A2532, 3S8A2676 and 3S8A2677 (Refer to Appendix 1.).</p> <p> DO</p>	<p>Unsuitable conduit connections for hazardous location can cause explosion.</p>







SAFETY PRECAUTIONS (continued)

Safety Precautions for Installation and Wiring

 CAUTION	
<p>■ Install a switch and fuse to isolate the LF414/LF600F, LF414/LF610F, LF414/LF620F and LF414 from mains power.</p> <p> Power supply from mains power can cause electric shock or circuit break-down.</p> <p>DO</p>	<p>■ Use an appropriate device to carry and install the LF414/LF600F, LF414/LF610F, LF414/LF620F and LF414.</p> <p> If this product falls to the ground, injury, or malfunction of or damage to the product, can be caused.</p> <p>DO</p>
<p>■ Turn off mains power before conducting wiring work.</p> <p> Wiring while power is applied can cause electric shock.</p> <p>DO</p>	<p>■ Do not modify or disassemble the LF414/LF600F, LF414/LF610F, LF414/LF620F and LF414 unnecessarily.</p> <p> Modifying or disassembling this product can cause electric shock, malfunction of or damage to this product.</p> <p>DON'T</p>
<p>■ Turn off mains power before working on pipes.</p> <p> Working on pipes while power is applied can cause electric shock.</p> <p>DO</p>	<p>■ Ground the LF414/LF600F, LF414/LF610F, LF414/LF620F and LF414 independently from power equipment. (100 ohm or less ground resistance)</p> <p> Operating this product without grounding can cause electric shock or malfunction.</p> <p>DO</p>
<p>■ Do not conduct wiring work with bare hands.</p> <p> Remaining electric charge even if power is turned off can still cause electric shock.</p> <p>DON'T</p>	<p>Use crimped terminal lugs for the terminal board and GND terminal.</p> <p> Loose connections can cause electric shock, fire from excessive current or system malfunction.</p> <p>DO</p>
<p>■ Do not work on piping and wiring with wet hands.</p> <p> Wet hands may result in electric shock.</p> <p>DON'T</p>	
<p> The label shown left is placed near the terminal board for power supply on the converter. (A black border and symbol on yellow triangle) Be alert to electric shock.</p>	

SAFETY PRECAUTIONS (continued)

Safety Precautions for Maintenance and Inspection

 CAUTION	
<p>■ Do not conduct wiring work with wet hands.</p> <div style="display: flex; align-items: center; margin-top: 10px;">  <div style="margin-left: 10px;"> <p>Wet hands may result in electric shock.</p> <p>DON'T</p> </div> </div>	<p>■ Do not conduct wiring work when power is applied.</p> <div style="display: flex; align-items: center; margin-top: 10px;">  <div style="margin-left: 10px;"> <p>Wiring while power is applied can cause electric shock.</p> <p>DON'T</p> </div> </div>
<p>■ Do not use a fuse other than the one specified.</p> <div style="display: flex; align-items: center; margin-top: 10px;">  <div style="margin-left: 10px;"> <p>Using a fuse other than the one specified can cause system failure, damage or malfunction.</p> <p>DON'T</p> </div> </div>	<p>■ Do not touch the LF414/LF600F, LF414/LF610F, LF414/LF620F and LF414 main body when high temperature fluid is being measured.</p> <div style="display: flex; align-items: center; margin-top: 10px;">  <div style="margin-left: 10px;"> <p>The fluid raises the main body temperature and can cause burns when touched.</p> <p>DON'T</p> </div> </div>
<div style="display: flex; align-items: center; margin-top: 10px;">  <div style="margin-left: 10px;"> <p>The label shown left is placed near the terminal board for power input of the converter. (A black border and symbol on yellow triangle) Be alert to electric shock.</p> </div> </div>	

Usage limitation

This product is **not manufactured for applying to a system requiring safety directly involved human life as follows**. Please contact your nearest Toshiba representative if there is a possibility of using this product for such use.

- **Main control systems of nuclear power plants, safety protection systems in nuclear facilities or other important systems requiring safety**
- **Medical control systems relating to life support**

Warranty and Limitation of Liability

Toshiba does not accept liability for any damage or loss, material or personal, caused as a direct or indirect result of the operation of this product in connection with, or due to, the occurrence of any event of force majeure (including fire or earthquake) or the misuse of this product, whether intentional or accidental.

Handling Precautions

To obtain the optimum performance from the LF600F, LF610F, LF620F, LF602F, LF612F and LF622F converter for years of continuous operation, observe the following precautions.

(1) **Do not store or install** the flowmeter in:

- **Places where there is direct sunlight.**
- Places where there is snow and ice
Infrared switches may not function correctly.
- Places where **excessive vibration or mechanical shock** occurs.
- Places where **high temperature or high humidity** conditions obtain.
- Places where **corrosive atmospheres** exist.
- Places **submerged under water.**
- Places **where there is a sloped floor.** To put the flowmeter temporarily on the floor, **place it carefully with something, such as a block, to support it so that the flowmeter will not topple over.**
- **Places where there is following factors.**
 - Factors to impede infrared switch to operate properly
 - Intense light such as direct sunlight and reflected sunlight by window glass or metal plate
 - Place where brightness changes suddenly such as ON/OFF of lighting
 - Dense smoke or steam near the control panel
 - Those attached on the control panel such as rain (dew drop), snow, ice, mud and oil, and haze due to their attachment
 - Light reflecting object near the control panel, or reflecting object such as metal plate placed opposing to the control panel

When any of above factors is considered, take a measure for the proper operation of infrared switch such as to place a cover or to secure a space for at least a person to stand in front of the control panel.

When unable to avoid above factors, operate the EMF converter removing the factor by covering the control panel by hand so that light does not shine on it, by cleaning those attached on the control panel, or by standing in-between the reflecting object and the control panel to block the light.

(2) Wire cables **correctly and securely.**

Be sure to ground at the converter side (**grounding resistance 100Ω or less**).

Avoid a common ground **used with other equipment** where earth current may flow. An **independent ground** is preferable

(3) Select cable paths away from electrical equipment (motors, transformers, or radio transmitters), which causes electromagnetic or electrostatic interference.

(4) The apparatus should not be provided with the cable connections.

Please prepare yourself for the cable connections which could be used in Division2 hazardous locations.

The cable lead-in section must be tightened securely to keep air tightness.

Handling Precautions (continued)

- (5) If the inside of the converter and detector's terminal box are wetted or humidified, it may cause insulation deterioration, which can result in **fault or noise occurrence**. So do not conduct **wiring in the open air on rainy days**.
Also, be careful not to wet down the converter and detector's terminal box even in the case of indoor wiring, and complete wiring work in a short period of time.
- (6) **Observe the following precautions when you open the converter housing cover:**
- **Do not open the cover in the open air unprotected against rain or wind.** This can cause **electric shock** or cause **damage to the flowmeter electronics**.
 - **Do not open the cover under high ambient temperature or high humidity conditions or in corrosive atmospheres.** This can cause **deterioration of system accuracy** or cause **damage to the flowmeter electronics**.
- (7) Since a varistor is built in converter, **do not conduct a withstand voltage test for the converter**.
In addition, the voltage for checking the insulation of the converter must be **250VDC or lower**.
- (8) This product may cause **interference to radio and television sets** if they are used near the installation site. **Use metal conduits etc. for cables to prevent this interference**.
- (9) Radio transmitters such as transceivers or cellular phones may cause interference to the flowmeter if they are used near the installation site. Observe the following precautions when using them:
- **Close a transmitter cover** before using a transceiver.
 - Do not use a transceiver whose output power is more than **5 W**.
 - Move the antenna of a transceiver or a cellular phone **at least 50 cm** away from the flowmeter and signal cables when using it.
 - **Do not use a radio transmitter or a cellular phone near the flowmeter** while it is operating online. The transmitter or cellular phone's output impulse noise may interfere with the flowmeter.
 - **Do not install a radio transmitter antenna** near the flowmeter and signal cables.
- (10) For reasons of flowmeter failure, inappropriate parameters, unsuitable cable connections or poor installation conditions, the flowmeter may not operate properly. To prevent any of these problems causing a system failure, **it is recommended that you have preventive measures designed and installed on the flowmeter signal receiving side**.
- (11) **For installation and connection of the converter, check the model number of converter and read the instruction manual of the relevant converter.**

* We assume no responsibility for nonconformity caused by violation of precautions described in this manual or used in violation of the installation method and the operation method stipulated in a relevant ordinance or other regulations.

Table of Contents

SAFETY PRECAUTIONS	2
Handling Precautions	6
1. Product Inspection and Storage	9
1.1 Product Inspection	9
1.2 Storage	9
2. Overview	10
3. Names of Parts	11
4. Installation	24
4.1 Notes on Selecting the Installation Location	25
4.2 Mounting Procedure	25
4.3 Piping Connections	29
4.4 Grounding	32
5. Wiring	34
5.1 Cables	36
5.2 External Device Connections and Grounding	37
5.3 Notes on Wiring	37
5.4 Wiring	38
6. Operation	41
7. Maintenance and Troubleshooting	42
7.1 Maintenance	43
7.2 Troubleshooting	44
8. Principle of Operation	47
9. Specifications	48
9.1 Flowmeter Specifications	48
9.2 Type Specification Code	52
10. Outline Dimensions	54
Appendix 1 (A system block diagram)	60

1. Product Inspection and Storage

1.1 Product Inspection

LF414 series electromagnetic flowmeter is shipped in a cardboard container filled with shock-absorbing materials. Open the package carefully and check as follows:

- Make sure the following items are included in the package.

For the **integral type** (when a converter and detector are united)

Integral	Electromagnetic flowmeter main unit ----- 1 unit
	Instruction manual-----One each for the converter and detector

For the separate type (when a converter and detector are separated)

Separate	Electromagnetic flowmeter converter----- 1 unit
	Electromagnetic flowmeter detector ----- 1 unit
	Instruction manual-----Once each for the converter and detector

- Inspect the flowmeter for indications of **damage** that may have occurred during shipment.
- Make sure the type and specifications of the flowmeter are in accordance with the **ordered specifications**.

If you cannot find the items listed above or any problem exists, contact your nearest Toshiba representative.

1.2 Storage

To store the electromagnetic flowmeter after opening the package, select a storing place as follows and keep it under the conditions described below:

CAUTION

- (1) Avoid places where there is **direct sunlight, rain or wind**.
- (2) Store the product in a well-ventilated place. Avoid places of **extremely high humidity** or **extremely high or low temperature**. The following environment is recommended:
 - **Humidity range: 10 to 90% RH (no condensation)**
 - **Storage temperature: -25 to +65° C**
- (3) Avoid places where **vibrations or mechanical shock occur**.
- (4) If the cover of the converter is left open while being stored, gradual deterioration of circuit isolation can be caused. Therefore **don't open the cover** until it is connected with wires.
- (5) To put the flowmeter temporarily on the floor, **place it carefully with something, such as block orstopper, to support it so that the flowmeter will not topple over**.

2. Overview

The LF414/LF600F, LF414/LF610F, LF414/LF620F and LF414 electromagnetic flowmeter can be used in the following hazardous (classified) locations.

Class I, Division 2, Groups A, B, C and D,
Class I, Division 2, Groups E, F and G
Class II

This product is a converter used for electromagnetic flowmeters that measure the volumetric flow rate of conductive fluid using Faraday's law of electromagnetic induction.

You can bring out the functions of the converter when you place it in the converter housing you prepare and use it in combination with a fluid rate measurement detector.

The converter sends out a signal to drive the detector excitation coil, which generates a magnetic field inside the detector. The converter receives the signal electromotive force obtained by the detector. The signal electromotive force is proportional to the generated flow rate in the fluid using Faraday's law of electromagnetic induction. After carrying out its operation, the converter converts the signal electromotive force to an analog signal output and displays the status, as a flow rate value.

Features

With a **linear relationship between the flow rate and output signal**, the electromagnetic flowmeter is used as an easy-to-read indicator. In addition to this feature, it has the following outstanding features:

- (1) Wide flow velocity range setting, such as a flow velocity range of 0 to 0.3 ft/s and 0 to 32.8 ft/s (0 to 0.1 and 0 to 10m/s) is achieved.
- (2) **The unique Noise Sentry filter circuit** enables you to obtain **stable output automatically**.
- (3) Full graphic LCD that enables display of a large amount of information
With a large amount of a maximum of 14 characters x 8 lines, you can easily set up various displays including bar graphs and alarm indications.
The backlight display allows you to read the indicator easily.
- (4) Use of infrared switches
Use of infrared switches allows you to perform various operations, without opening the converter housing cover.
- (5) **Intelligent functions**
The widely used **HART protocol communications system** is used as a standard feature.
This product supports **PROFIBUS^{*2} communication** (optionally available).

* 1 HART protocol: "HART" stands for Highway Addressable Remote Transducer and is a communication protocol recommended by HCF (HART communication Foundation) for industrial sensors.

* 2 PROFIBUS: PROFIBUS, which stands for PROCESS FIELDBUS, is a field bus that is approved by international standard IEC61158. The electromagnetic flowmeter supports PROFIBUS PA for process automation.

3. Names of Parts

IMPORTANT

The apparatus should not be provided with the cable connections.
Please prepare yourself for the cable connections which could be used in Division2 hazardous locations.

3.1 Appearance

3.1.1 Appearance of LF414/LF600F, LF414/LF610F

Integral (1) Meter size of 1/2 inch (15mm)

For the detail of the converter, check the LF600F, LF610F converter's instruction manual.

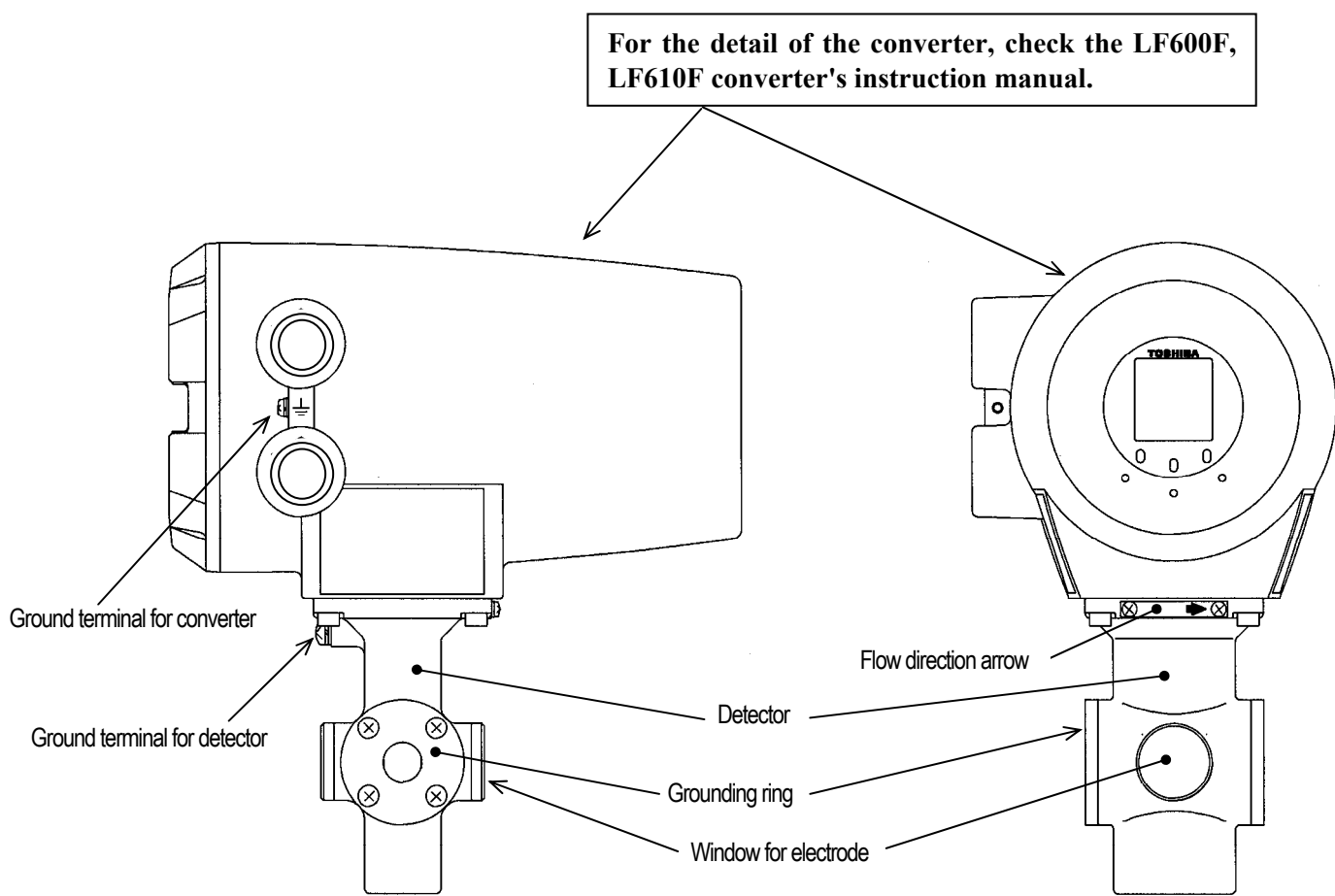

**Figure 3.1.1 Appearance of LF414/LF600F, LF610F
Meter size 1/2inch(15mm)**

(2) Meter size of 1 inch (25mm)

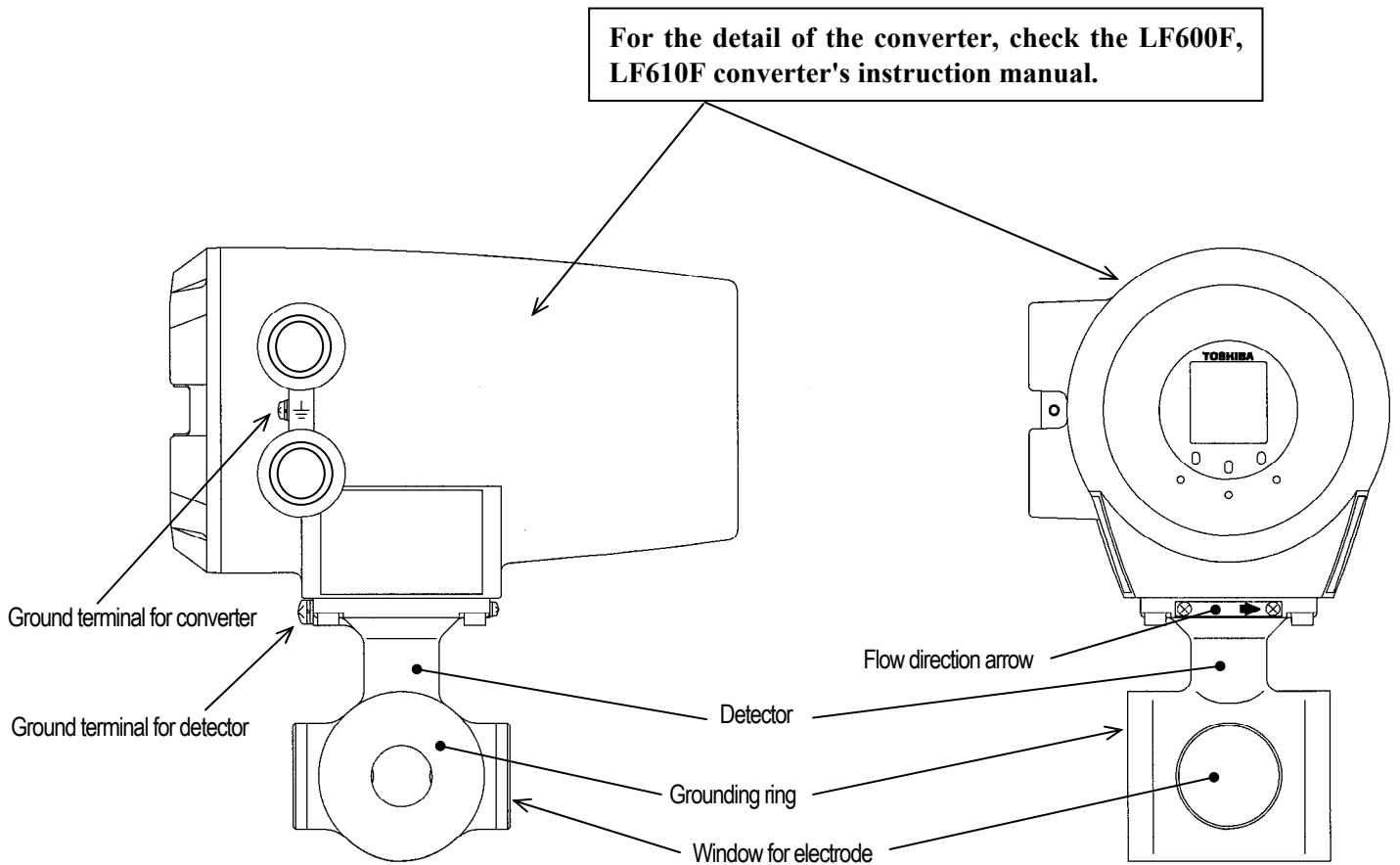

**Figure 3.1.2 Appearance of LF414/LF600F, LF610F
Meter size 1 inch(25mm)**

(3) Meter size of 1 1/2 to 4 inch (40 to 100mm)

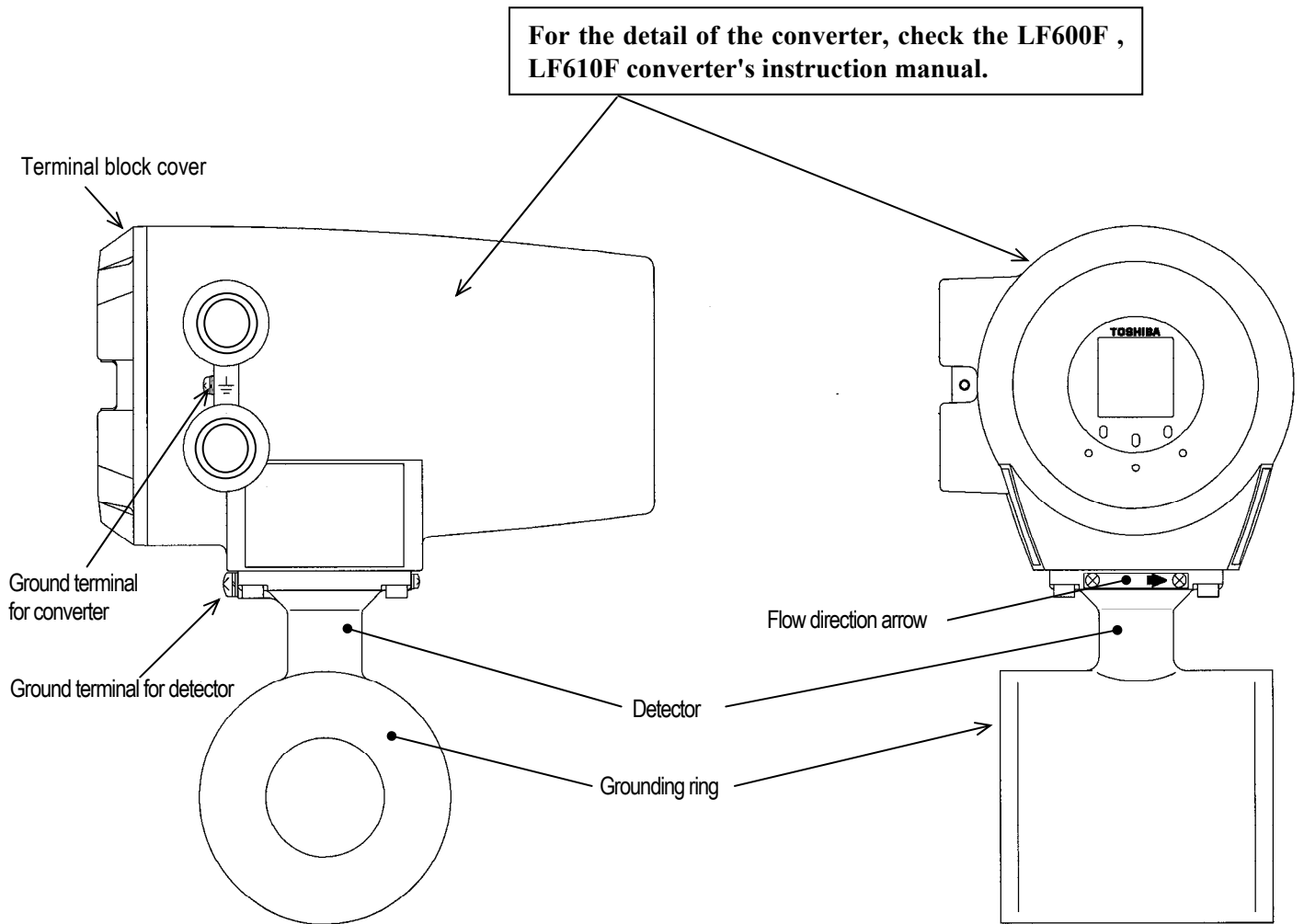

**Figure 3.1.3 Appearance of LF414/LF600F, LF610F
Meter size 1 1/2 to 4 inch (40 to 100mm)**

(4) Meter size of 6 and 8 inch (150 and 200mm)

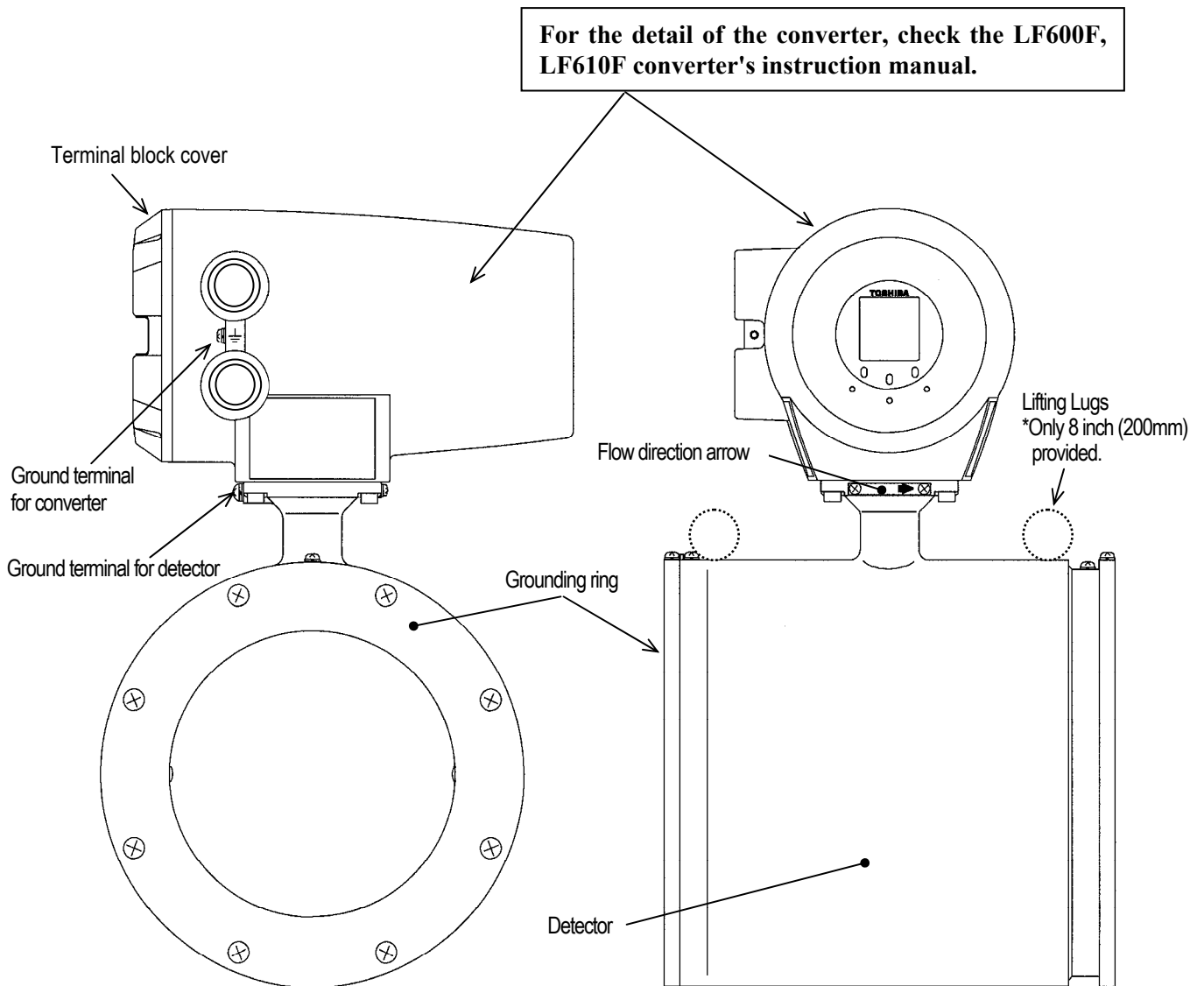
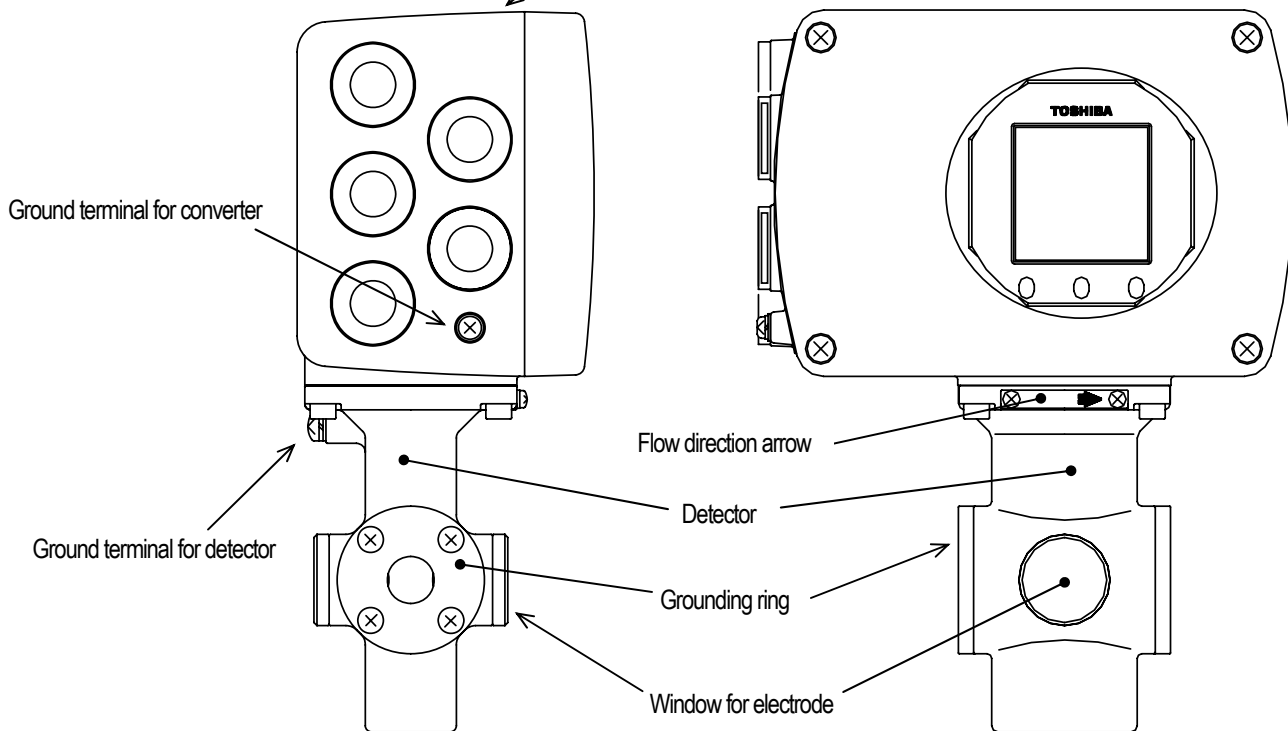

**Figure 3.1.4 Appearance of LF414/LF600F, LF610F
Meter size 6 and 8 inch(150 and 200mm)**

3.1.2 Appearance of LF414/LF620F

Integral (1) Meter size of 1/2 inch (15mm)

For the detail of the converter, check the LF620F converter's instruction manual.



**Figure 3.1.5 Appearance of LF414/LF620F
Meter size 1/2inch(15mm)**

(2) Meter size of 1 inch (25mm)

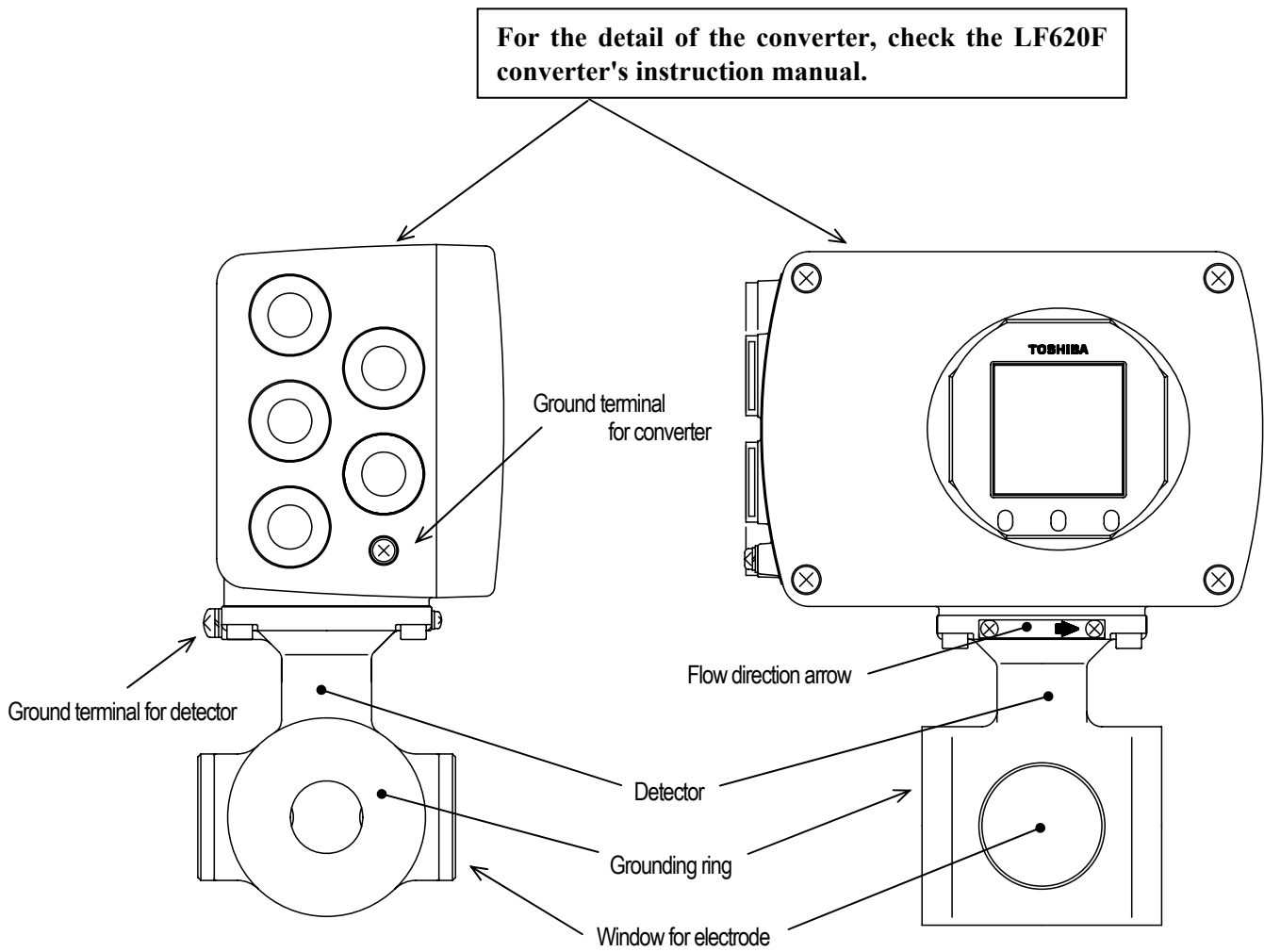

**Figure 3.1.6 Appearance of LF414/LF620F
Meter size 1 inch(25mm)**

(3) Meter size of 1 1/2 to 4 inch (40 to 100mm)

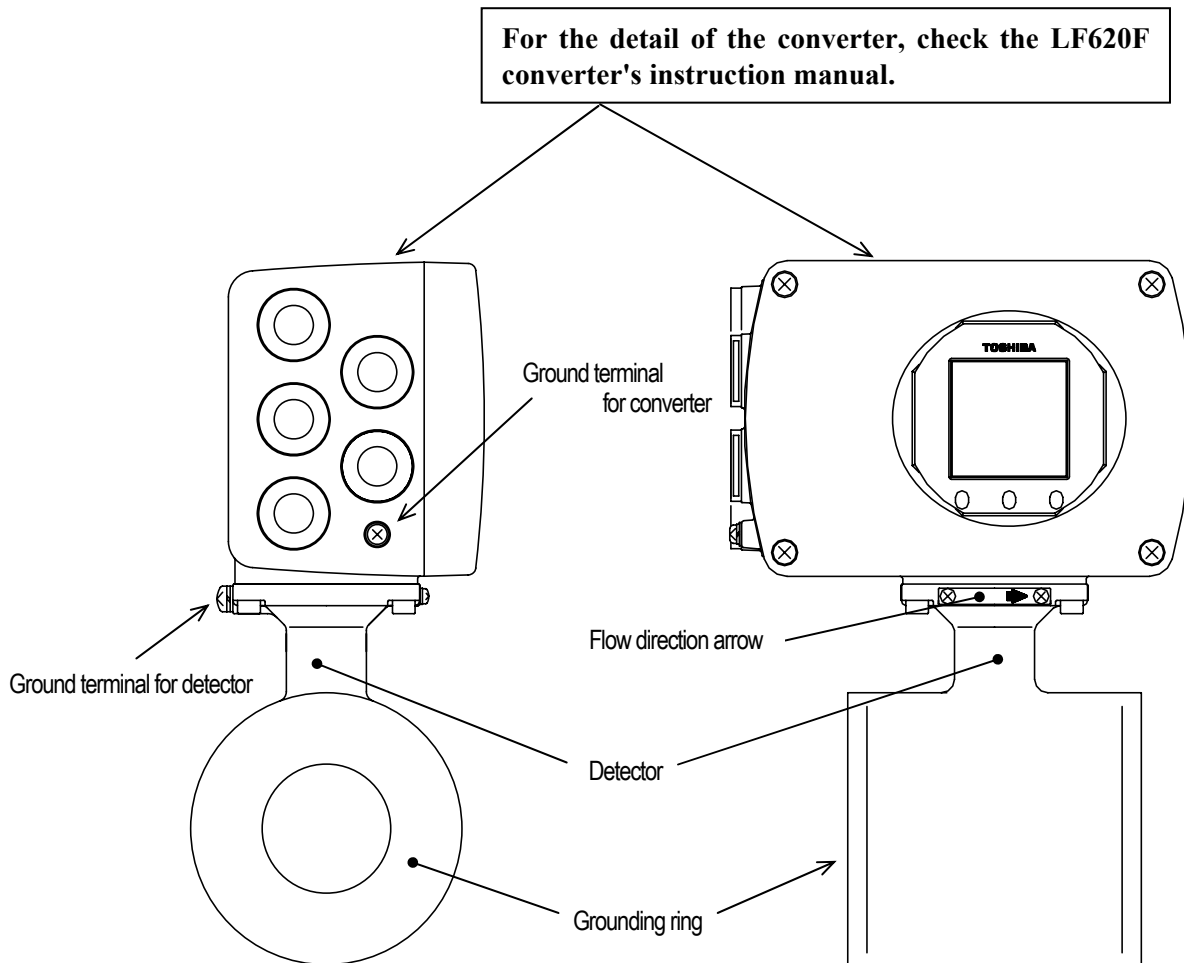

**Figure 3.1.7 Appearance of LF414/LF620F
Meter size 1 1/2 to 4 inch (40 to 100mm)**

(4) Meter size of 6 and 8 inch (150 and 200mm)

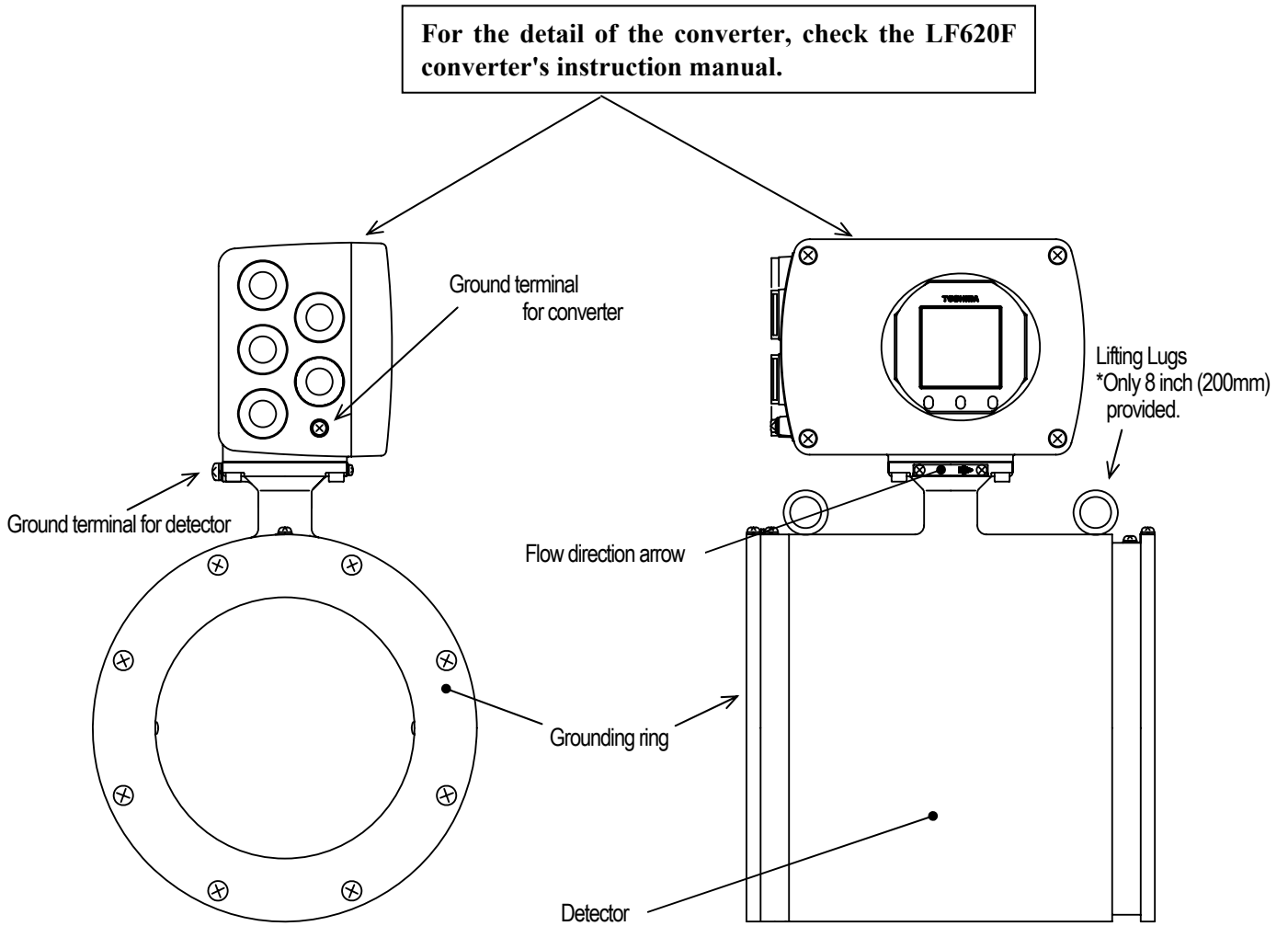

**Figure 3.1.8 Appearance of LF414/LF620F
Meter size 6 and 8 inch (150 and 200mm)**

3.1.3 Appearance of LF414

Separate (1) Meter size of 1/2 inch (15mm)

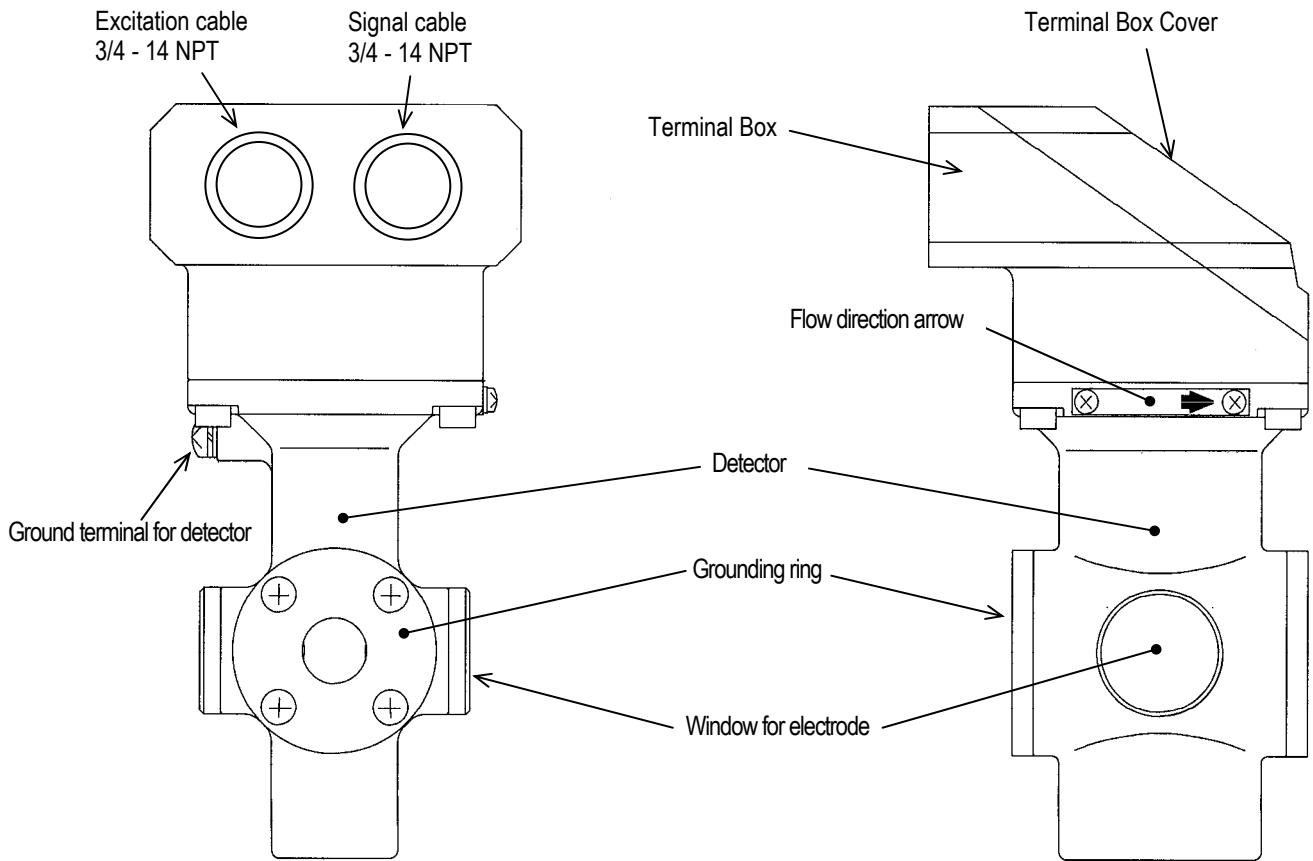

**Figure 3.1.9 Appearance of LF414
Meter size 1/2inch(15mm)**

(2) Meter size of 1inch (25mm)

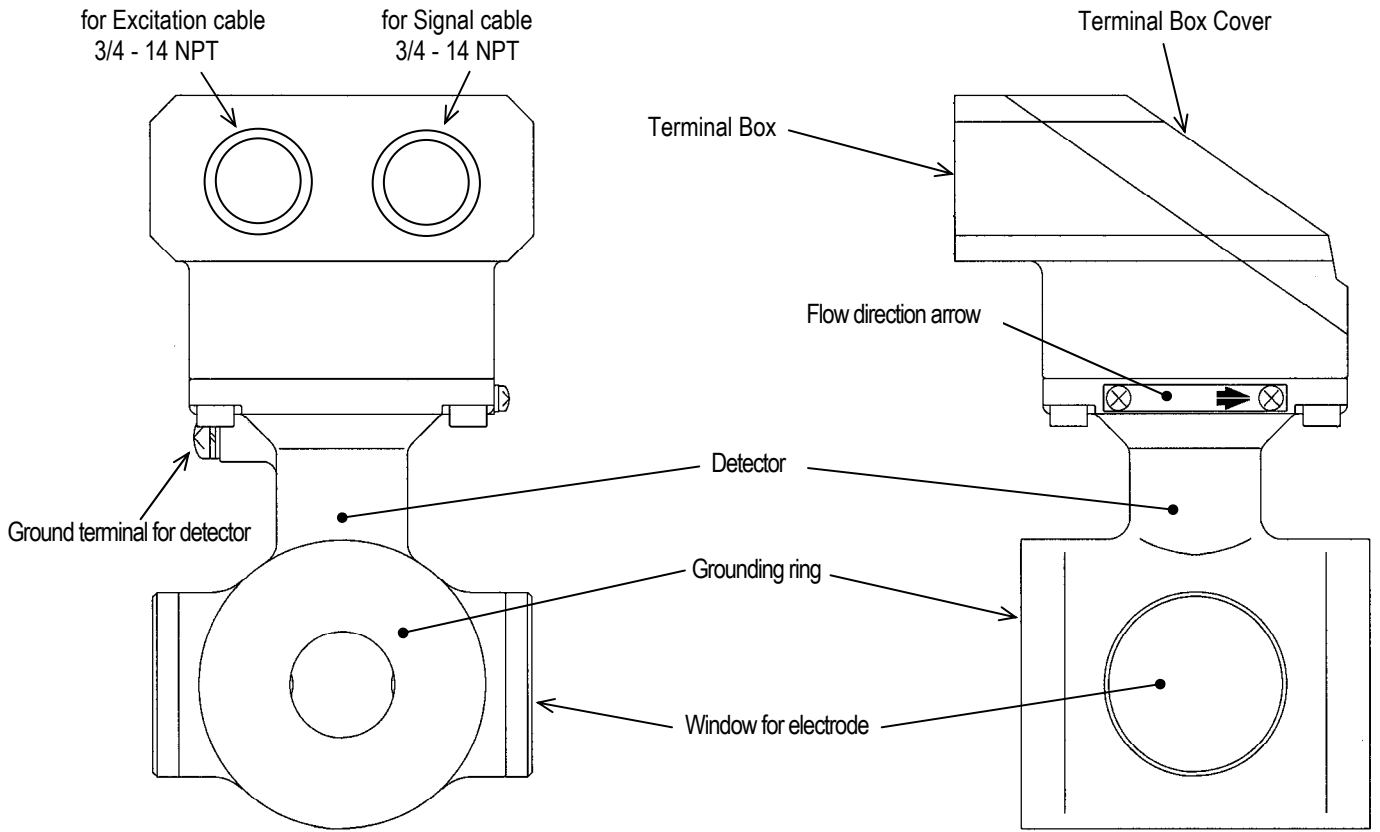

**Figure 3.1.10 Appearance of LF414
Meter size 1 inch(25mm)**

(3) Meter size of 1 1/2 to 4 inch (40 to 100mm)

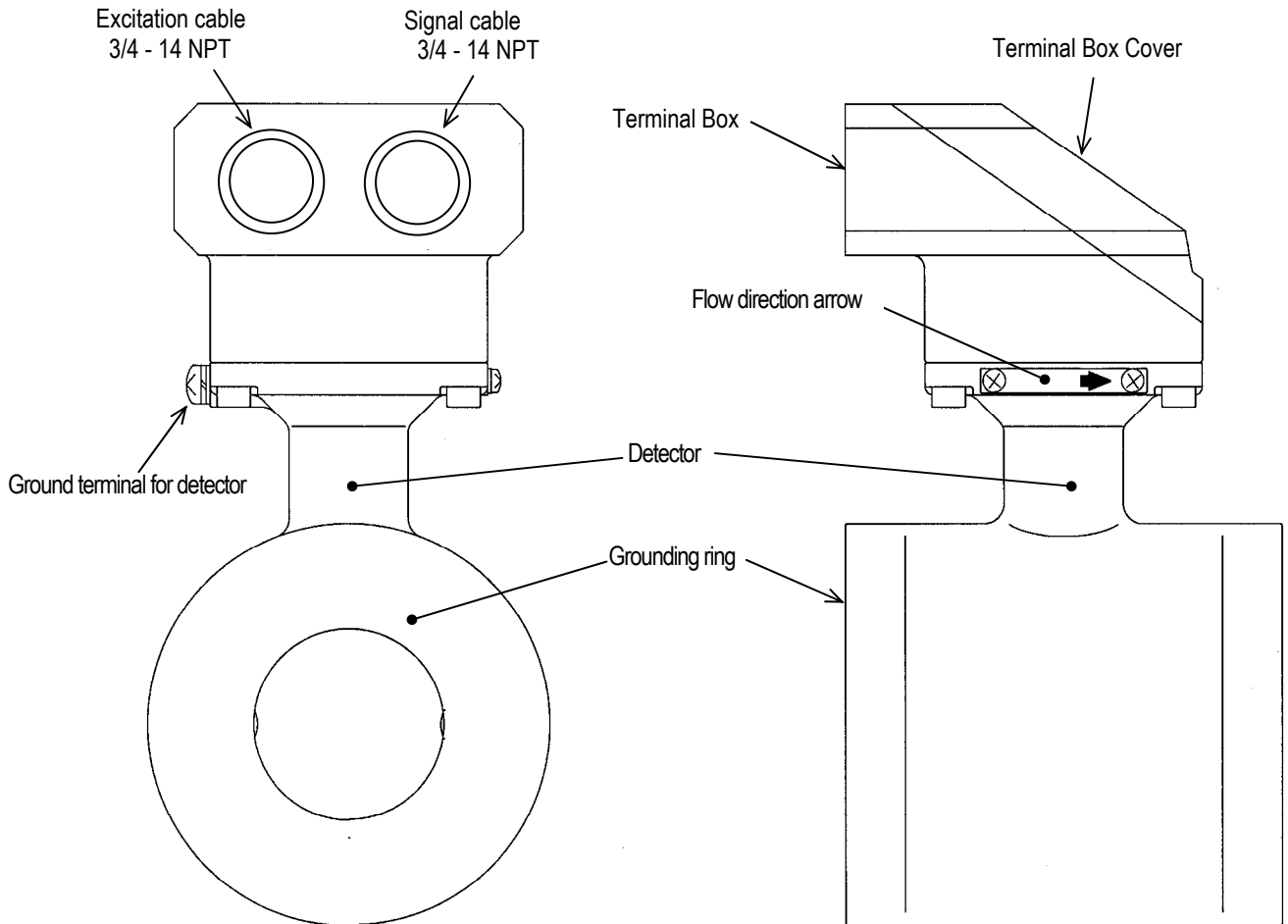

**Figure 3.1.11 Appearance of LF414
Meter size 1 1/2 to 4 inch (40 to 100mm)**

(4) Meter size of 6 and 8 inch (150 and 200mm)

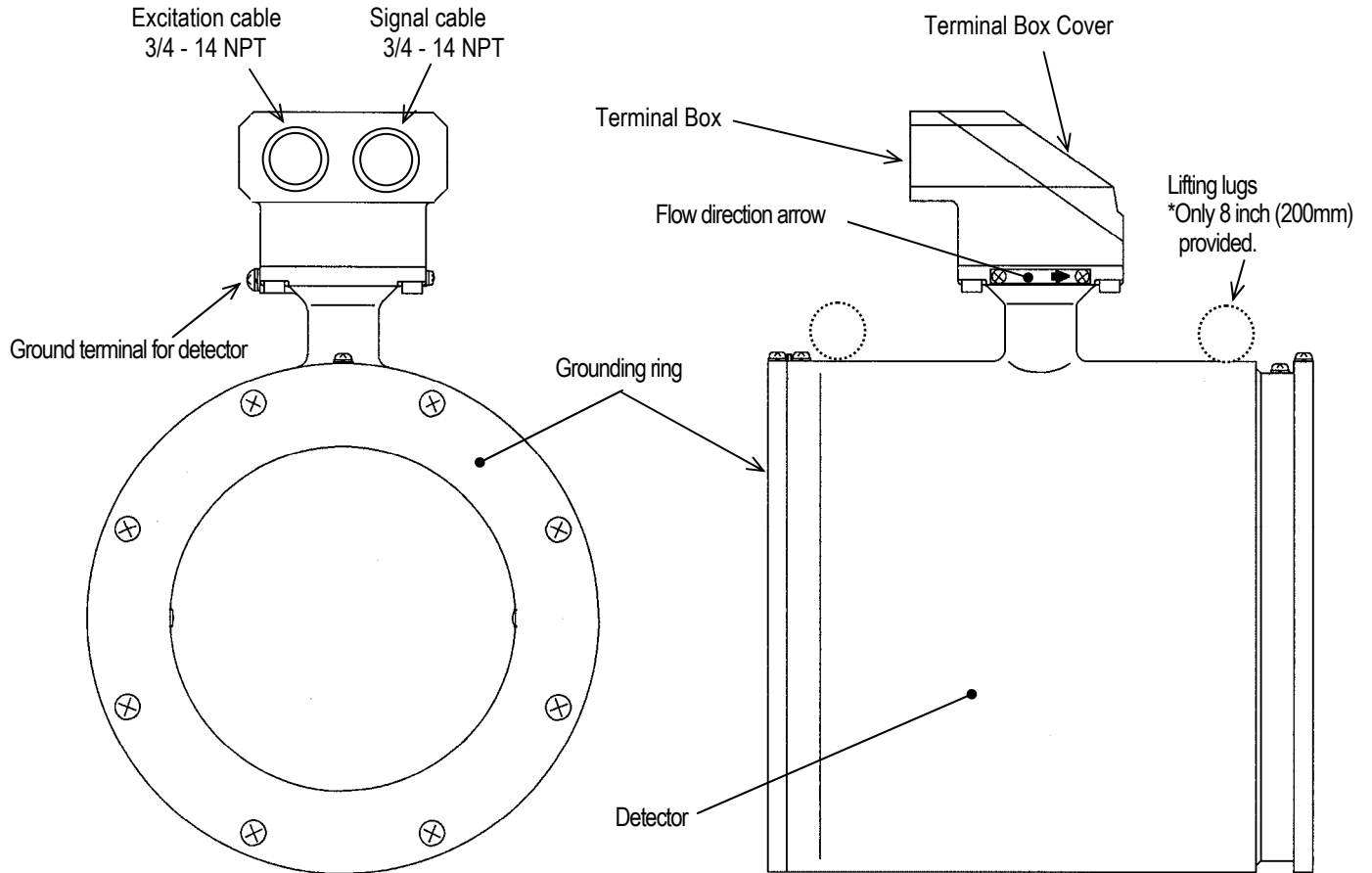

**Figure 3.1.12 Appearance of LF414
Meter size 6 and 8 inch(150 and 200mm)**

3.2 Construction of the terminal blocks

3.2.1 Terminal Block Construction of LF414/LF600F, LF414/LF610F and LF414/LF620F Type

Integral

For details of the converter, check the LF600F, LF610F and LF620F converter's instruction manual.

3.2.2 Terminal Block Construction of LF414 Type

Separate

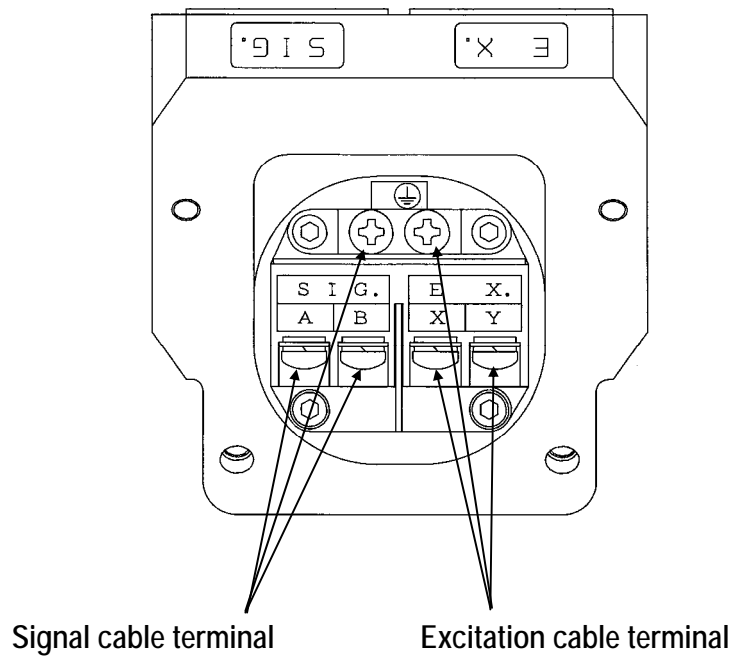













Figure 3.2 Terminal Block of LF414

4. Installation

Safety Precautions for Installation

 WARNING	
<p>■ Do not live active circuits under environment of explosive atmospheres.</p> <p> DON'T</p>	<p>Live part of electric circuit or a high temperature department can cause explosion.</p>
<p>■ Do not use parts of other products.</p> <p> DON'T</p>	<p>Protective performance degradation for hazardous location can cause explosion.</p>
<p>■ Do not active live circuits While assembly of all components is not over.</p> <p> DON'T</p>	<p>Protective performance degradation for hazardous location can cause explosion.</p>
<p>■ Install per the National Electrical Code for the US (NEC, ANSI/NFPA 70) and the Canadian Electrical code for Canada (CEC, CAN/CSA-C22.1) and the drawing 3S8A2532, 3S8A2676 and 3S8A2677 (Refer to Appendix 1).</p>	
<p> DO</p>	<p>Unsuitable conduit connections for hazardous location can cause explosion.</p>

 CAUTION	
<p>■ Ground the LF414/LF600, LF414/LF610F, LF414/LF620F and LF414 independently from power equipment. (100 ohm or less ground resistance)</p> <p> DO</p>	<p>■ Use an appropriate device to carry and install the LF414/LF600, LF414/LF610F, LF414/LF620F and LF414.</p> <p> DO</p>
<p>■ Install a switch and fuse to isolate the LF414/LF600F, LF414/LF610F, LF414/LF620F and LF414 from mains power.</p> <p> DO</p>	<p>■ Do not modify or disassemble the LF414/LF600F, LF414/LF610F, LF414/LF620F and LF414 unnecessarily.</p> <p> DON'T</p>
<p>■ Do not work on piping and wiring with wet hands.</p> <p> DON'T</p>	<p></p> <p>The label shown left is placed near the terminal board for power supply to the converter. Be alert to electric shock</p>

4.1 Notes on Selecting the Installation Location

1. Avoid places within the immediate proximity of equipment producing electrical interference (such as **motors, transformers, radio transmitters, electrolytic cells, or other equipment causing electromagnetic or electrostatic interference**).
2. **Avoid places where excessive pipe vibration occurs.**
3. Avoid places where fluid is pumped in a pulsating manner.
4. Avoid places where there is **direct sunlight**. If this is unavoidable, use an appropriate **shade**
5. Avoid places where **corrosive atmospheres or high humidity conditions** occur.
6. Avoid places where **there may be limited access such as pipes installed next to high ceilings or constricted areas** where clearance for installation or maintenance work is not provided.
7. Design piping so that the detector pipe is always filled with fluid, whether the fluid is flowing or not.
8. The detector has no adjustable piping mechanism. Install an adjustable short pipe where needed.
9. Chemical injections should be conducted on the downstream side of the flowmeter.
10. The maximum length of the cable that connects **the detector and converter is 300m**. Select the converter installation location so that the distance between the detector and converter does not exceed 300m.

Separate

4.2 Mounting Procedure

4.2.1 Pipe checks

(1) Before installing pipes, check for any leaning, misplacement or eccentricity as illustrated in Figure 4.1.

An attempt to unreasonably connect pipes that are inclined may lead to a detector breakdown or fluid leakage. Connecting pipes in an eccentric state may also cause wear and tear of linings and grounding rings, as well as measurement errors.

Before installing pipes, make sure to flush the interior of the pipes to remove deposited material..

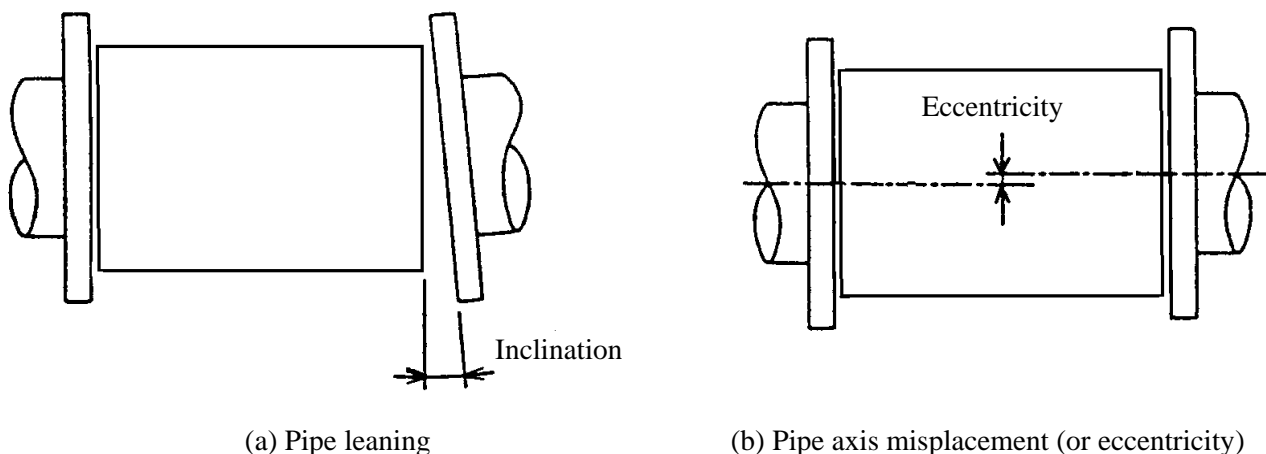

Figure 4.1 Pipe leaning and axis misplacement

(2) Preventing an Empty Pipe Condition

Fix the relevant pipes installed on both sides of the detector by attaching fittings, etc. to support the pipe. By supporting the pipes, not only the pipe vibration is reduced but also the damage to the pipes by the electromagnetic flowmeter's weight and the fluid mass (see Figures 4.2 and 4.3).

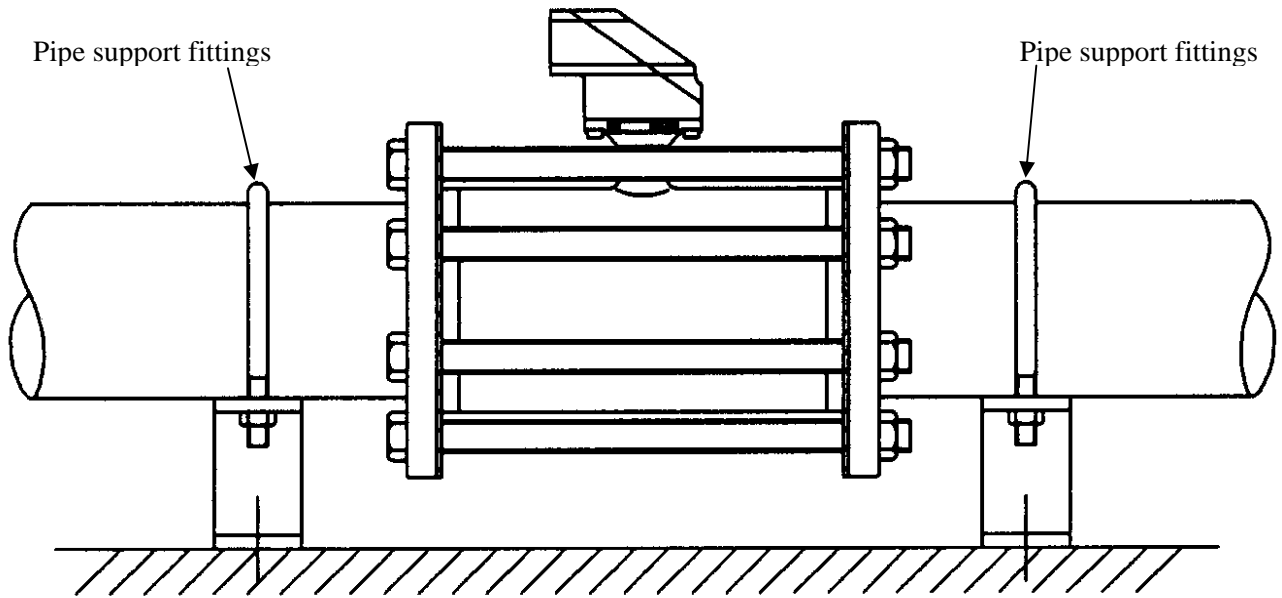

Figure 4.2 Example of Pipe Fixing Procedure

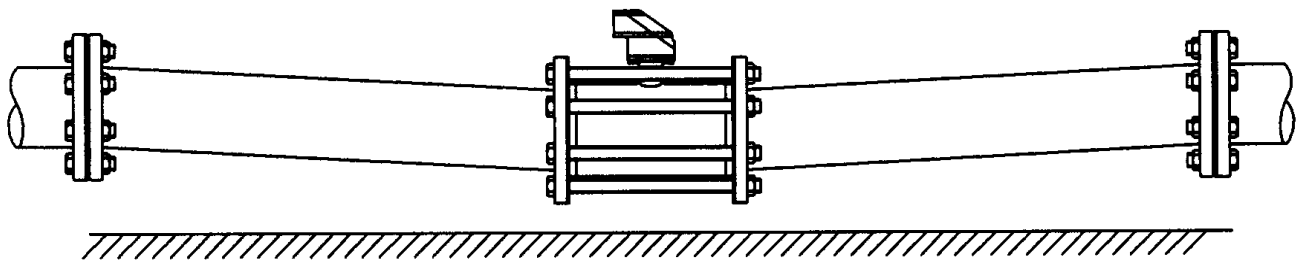

Figure 4.3 Model Diagram of Unsupported Pipes

4.2.2 Installation Procedure

To mount the LF414, place it between the upstream and downstream pipe flanges and tighten it with flange bolts and nuts. See Figure 4.4 and follow the procedure below:

1. Insert two lower mounting bolts through the clearance holes in the upstream (or downstream) pipe flange.
2. Install a packing next to the upstream (or downstream) flange face and the other packing next to the downstream (or upstream) pipe flange. The two mounting bolts can now be guided through the clearance holes in the downstream packing and flange.
3. Place the LF414 flowmeter detector between the two flange packings, with the flowmeter detector body above the two bolts. The flowmeter must be oriented in accordance with the flow direction arrow.
4. Install the two upper mounting bolts through the clearance holes in the upstream and downstream packings and flanges. Then install the remaining mounting bolts depending on the flange pattern used.
5. Thread nuts on both ends of the 4 (or more) mounting bolts, finger tight. **(See Table 4.1 Bolt length and tightening torque)**
6. While centering the flowmeter with the longitudinal axis of the pipeline, tighten the nuts with a wrench diagonally across in even increments. **(See Table 4.1 Bolt length and tightening torque)**

Note that the flowmeter detector pipe axis must be aligned with the pipeline axis on both upstream and downstream sides. This is essential to have stable characteristics of flow measurement (especially for flowmeters with meter sizes of 50 mm or less).

IMPORTANT

When high-temperature fluid is being measured, radiant heat from the detector pipe surface and adjoining pipes may cause the ambient temperature of the converter to go above 60 °C. If the ambient temperature goes above 60° C, try to lower the temperature by measures such as wrapping heat-insulating materials over the detector pipe and adjoining pipes.

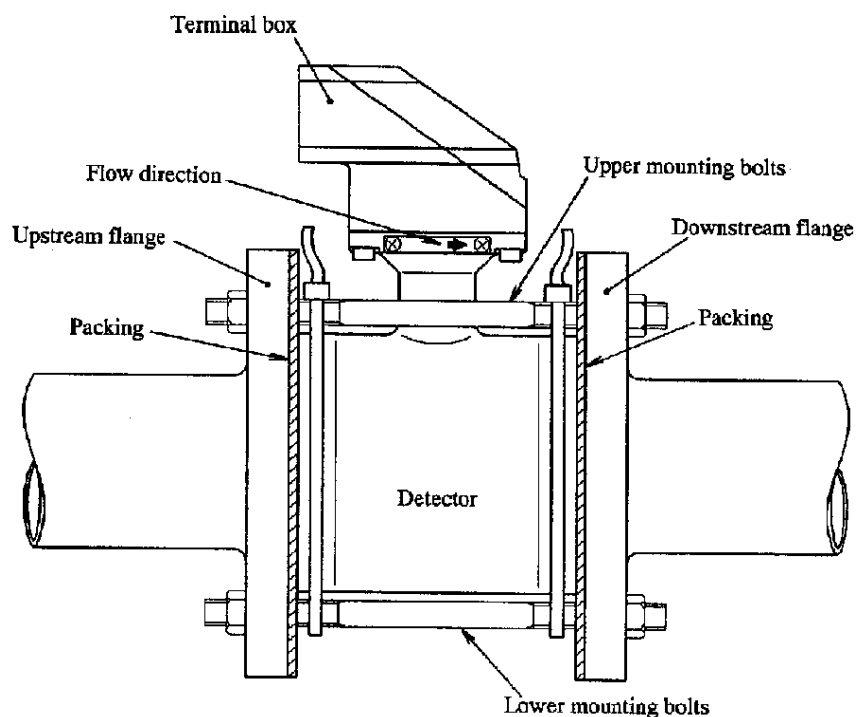

Figure 4.4 LF414 flowmeter detector piping connections

Table 4.1 Bolt length and Nut tightening torque

Meter size		ASME B 16.5 class 150				ASME B 16.5 class 300			
		Through Bolts			Tightening torque [N·m]	Through Bolts			Tightening torque [N·m]
		P.C.S	Dia-meter	Length [mm]		P.C.S	Dia-meter	Length [mm]	
15mm	1/2"	4	1/2"	150	12 to 15	4	1/2"	155	25 to 31
25mm	1"	4	1/2"	170	21 to 26	4	5/8"	180	53 to 66
40mm	1 1/2"	4	1/2"	195	32 to 40	4	3/4"	215	96 to 120
50mm	2"	4	5/8"	215	52 to 65	8	5/8"	220	52 to 65
80mm	3"	4	5/8"	225	71 to 88	8	3/4"	240	85 to 106
100mm	4"	8	5/8"	235	52 to 65	8	3/4"	255	125 to 156
150mm	6"	8	3/4"	355	104 to 130	12	3/4"	375	138 to 173
200mm	8"	8	3/4"	430	146 to 183	12	7/8"	460	227 to 284

Meter size		EN 1092-1 PN 10/16				JIS B 2220 10K			
		Through Bolts			Tightening torque [N·m]	Through Bolts			Tightening torque [N·m]
		P.C.S	Dia-meter	Length [mm]		P.C.S	Dia-meter	Length [mm]	
15mm		4	M12	150	16 to 19	4	M12	150	10 to 13
25mm		4	M12	165	27 to 34	4	M16	170	22 to 28
40mm		4	M16	190	58 to 72	4	M16	190	32 to 40
50mm		4	M16	205	78 to 98	4	M16	200	43 to 53
80mm		8	M16	210	54 to 67	8	M16	210	27 to 34
100mm		8	M16	220	79 to 99	8	M16	215	37 to 46
150mm		8	M20	340	164 to 205	8	M20	340	70 to 88
200mm EN 1092-1 PN 10		8	M20	410	146 to 183	12	M20	410	60 to 75
200mm EN 1092-1 PN 16		12	M20	410	156 to 195				

4.3 Piping Connections

(1a) Ideal Upstream Straight Pipe Length Installation Requirements

If various joints are used upstream of the detector outlet, the straight pipe length as shown in Table 4.2 is required.

Table 4.2 Required straight pipe length on the upstream side

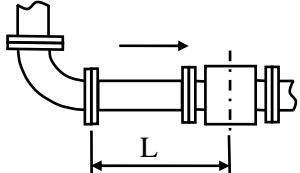
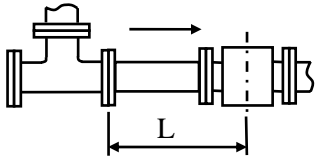
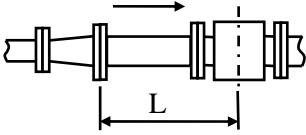
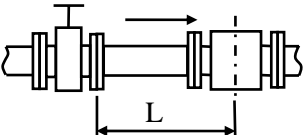
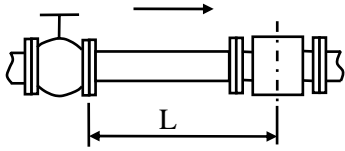
L=5D	L=10D
<p>(1) 90 ° bent</p>  <p>(2) Tee</p>  <p>(3) Diffuser</p>  <p>(4) Fully opened sluice valve</p> 	<p>(5) Other valves (not fully opened)</p> 

L: Required straight pipe length—straight pipe length plus half length of the detector.

D: Nominal bore size (diameter)

NOTES

The length of a reducer, if connected, can be counted as a part of the straight pipe length.

No straight pipe length is needed on the downstream side. If a butterfly valve is installed downstream of the detector, do not let the valve plate protrude into the pipe of the detector

(1b) Optional “Mount Anywhere” Installation

Mount-Anywhere Technology:

With Toshiba’s unique magnetic field distribution technology, the meter is highly immune to upstream flow disturbances. A minimum of 1D (diameter) length of upstream straight pipe from the flange is required to maintain the performance specification.

NOTE

The test results were obtained and demonstrated at Toshiba’s flow calibration facility, Fuchu Japan.

(2) Pipe Orientation

The detector may be installed in horizontal, vertical or sloping pipe runs as shown in Figure 4.5. However, except for horizontal installation, fluid should flow from lower to upper directions. If no air bubble, vertical down flow application are acceptable under pressured piping conditions. See Figure 4.5.

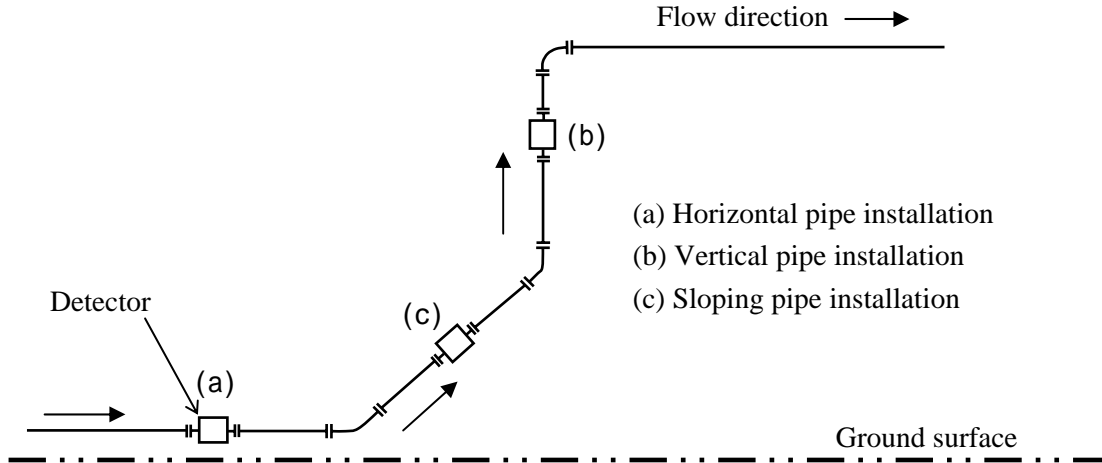

Figure 4.5 Detector Piping Orientation

The electrodes should be positioned horizontally relative to the ground surface in any piping installation. See Figure 4.6.

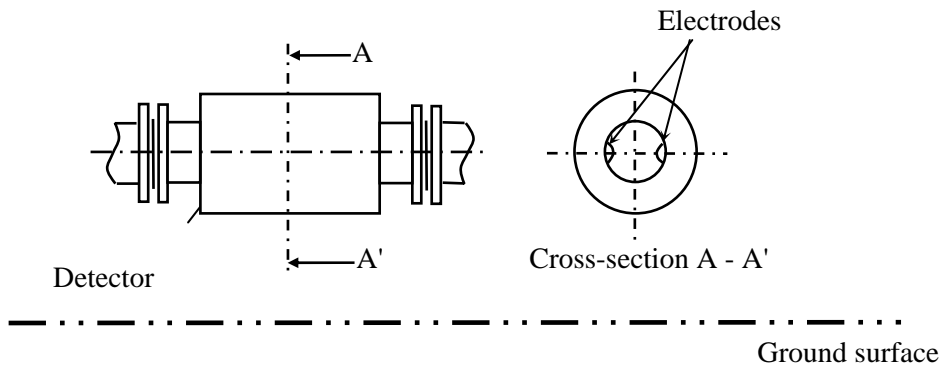

Figure 4.6 Installation position of the detector

(3) Flow Direction

Install the detector in accordance with the flow direction arrow on the detector. See Figure 4.7.

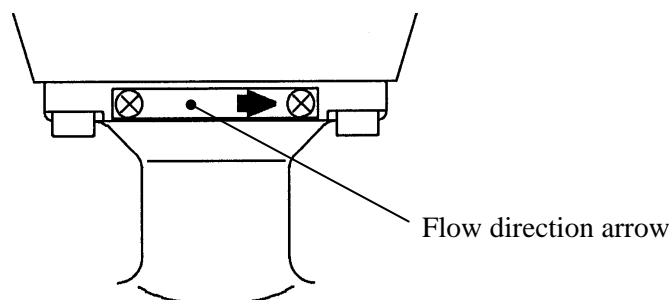

Figure 4.7 Flow direction arrow on the detector

(4) Preventing an Empty Pipe Condition

Design an upright pipe run (Figure 4.8) or sufficient head pressure (Fig. 4.9) at the downstream detector outlet if there is a possibility of the detector pipe becoming emptied.

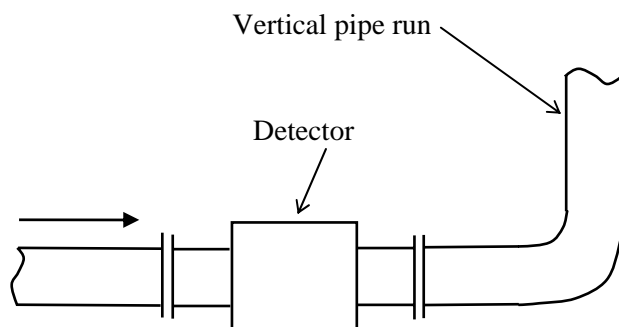

Figure 4.8 Detector with an upright pipe run at downstream outlet

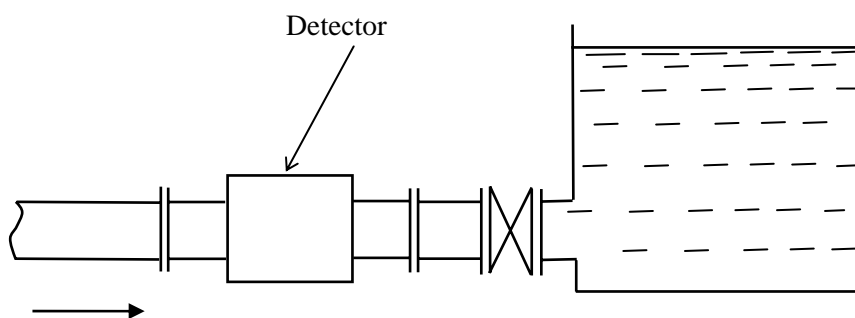





Figure 4.9 Detector with sufficient head pressure at downstream outlet

4.4 Grounding

 CAUTION	
<p>■ Do not wire cables and replace parts when power is supplied.</p> <p> Wiring work and replacing parts in the power-on state may cause electric shock.</p> <p>DON'T</p>	<p>■ Do not work on piping and wiring with wet hands.</p> <p> Wet hands may result in electric shock.</p> <p>DON'T</p>

(1) Grounding of the LF414/LF620F type

Integral

Ground as shown in Figure 4.10. Make the grounding wire as short as possible. Use **grounding wire material of IV wire 5.5mm² or more**. Do not share a grounding wire with other instruments where grounding current may flow. (An independent grounding is preferable.)

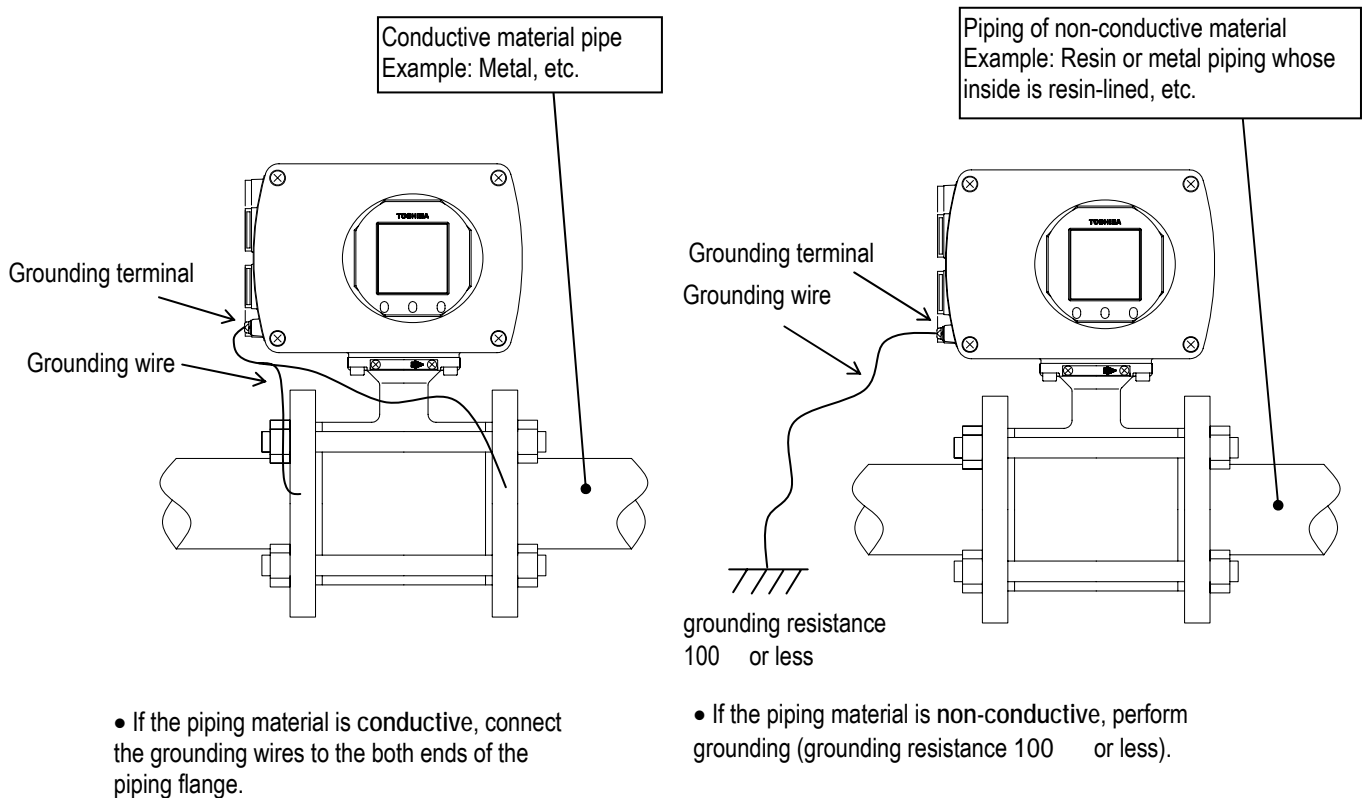

- If the piping material is **conductive**, connect the grounding wires to the both ends of the piping flange.

- If the piping material is **non-conductive**, perform grounding (grounding resistance 100 or less).

Figure 4.10 Grounding the LF414/LF620F Type

(2) Grounding of the LF414 type

Separate

Ground the external grounding terminal of the detector and the FG terminal of the converter (or external grounding terminal of the converter) securely (**grounding resistance 100 Ω or lower**). Use grounding wire material of **IV wire 5.5mm² or more**. **Do not share a grounding wire with other instruments where grounding current may flow. (An independent grounding is preferable.)**

If it is difficult to perform grounding work at the detector side because of a pit installation or other reasons, use a 3-core cable for the excitation cable and connect the E terminal of the detector to the E terminal of the converter. (The E terminal of the converter is internally connected with the FG terminal and the converter case.)

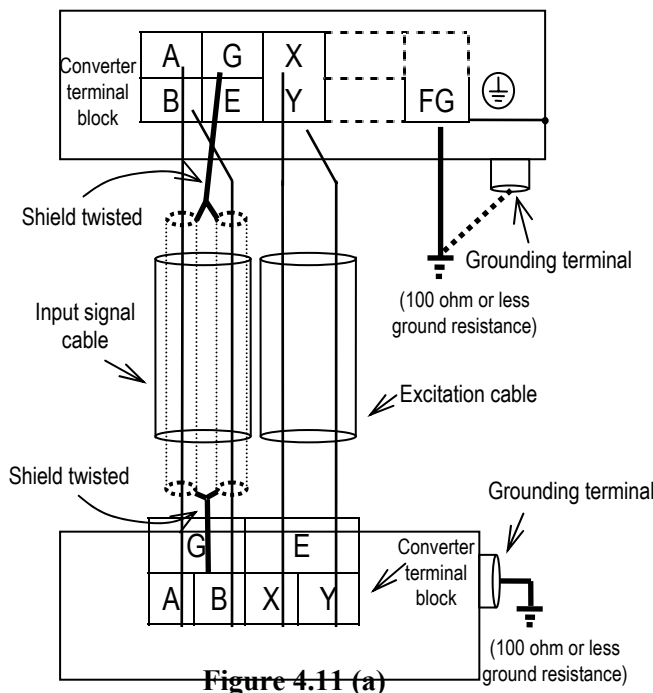

Figure 4.11 (a)

Wiring between Detector and Converter (For grounding the detector, see Figure 4.12 below.)

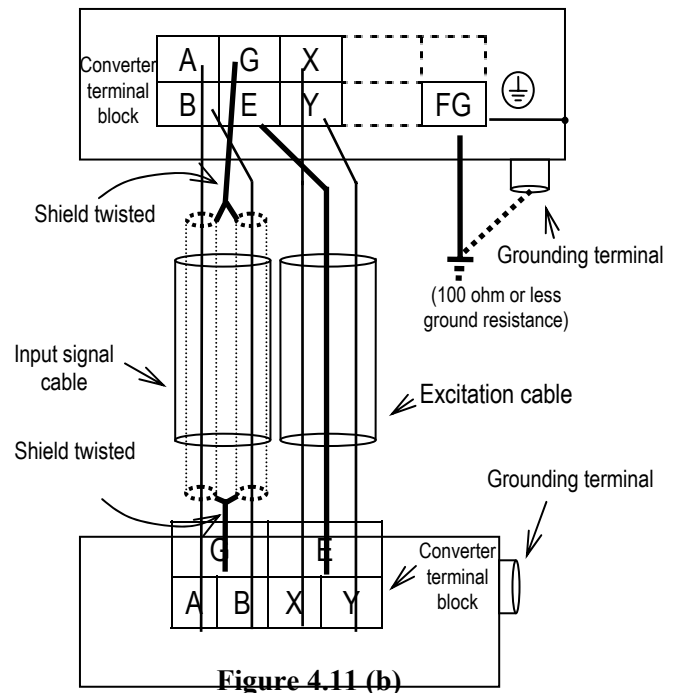
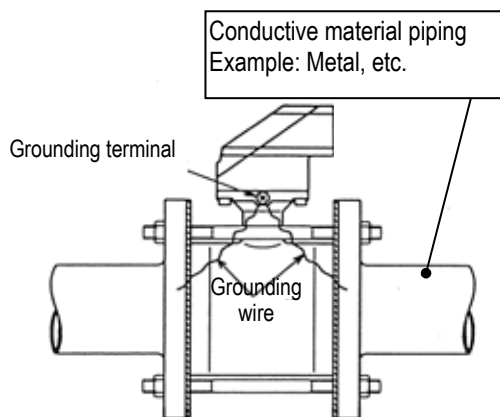
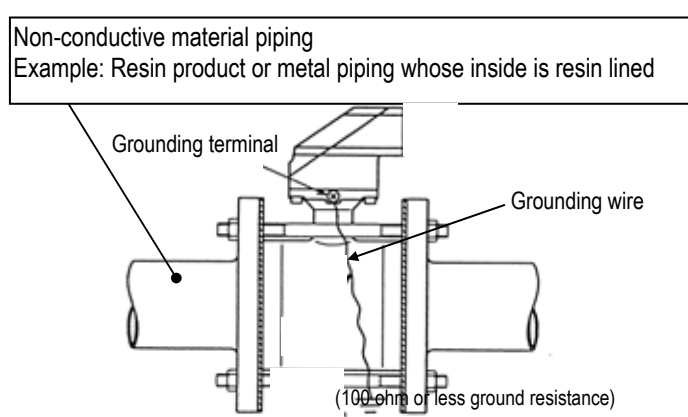

Figure 4.11 (b)

Wiring between Detector and Converter (when grounding of the detector is difficult)



- If the piping material is conductive, connect the grounding wires to the both ends of the piping flange.















- If the piping material is non-conductive, perform grounding resistance 100Ω or less.

Figure 4.12 Grounding the LF414 Type Detector

5.Wiring

Safety Precautions for Wiring

 WARNING	
<p>■ DO NOT DISCONNECT WHILE CIRCUIT IS LIVE UNLESS LOCATION IS KNOWN TO BE NONHAZARDOUS.</p> <p> DON'T</p>	<p>Live part of electric circuit or a high temperature department can cause explosion.</p>
<p>■ Do not active live circuits While assembly of all components is not over.</p> <p> DON'T</p>	<p>Protective performance degradation for hazardous location can cause explosion.</p>
<p>■ Install per the National Electrical Code for the US (NEC, ANSI/NFPA 70) and the Canadian Electrical code for Canada (CEC, CAN/CSA-C22.1) and the drawing 3S8A2532, 3S8A2676 and 3S8A2677 (Refer to Appendix 1).</p> <p> DO</p>	<p>Unsuitable conduit connections for hazardous location can cause explosion.</p>

 CAUTION	
<p>■ Install a switch and fuse to isolate the LF414/LF600F, LF414/LF610F, LF414/LF620F and LF414 from mains power.</p> <p> Power supply from mains power can cause electric shock or circuit break-down.</p> <p>DO</p>	<p>■ Turn off mains power before conducting wiring work.</p> <p> Wiring while power is applied can cause electric shock.</p> <p>DO</p>
<p>■ Do not work on piping and wiring with wet hands.</p> <p> Wet hands may result in electric shock</p> <p>DON'T</p>	<p>■ Ground the LF600F, LF610 and LF620 independently from power equipment. (100 ohm or less ground resistance)</p> <p> Operating this product without grounding can cause electric shock or malfunction.</p> <p>DO</p>
<p>■ Do not conduct wiring work with bare hands.</p> <p> Remaining electric charge even if power is turned off can still cause electric shock.</p> <p>DON'T</p>	<p>■ For the power supply wiring and grounding wiring, use crimping terminals with insulated sleeve.</p> <p> There is a risk of electric shock due to drop-off or loosing, and a risk of fire and equipment trouble due to heat generation.</p> <p>DO</p>
<p>Do not modify or disassemble the LF600F, LF610F, LF620F, LF602F, LF612F and LF622F unnecessarily.</p> <p> Modifying or disassembling this product can cause electric shock, malfunction of or damage to this product.</p> <p>DON'T</p>	<p> The label shown left is placed near the power supply terminal on the converter. Be alert to electric shock.</p>

Flowmeter accuracy may be affected by the way wiring is executed. Proceed with correct wiring taking the precautions in following pages.

Notes on wiring

⚠ CAUTION

- (1) Select the cable runs **away from electrical equipment (motors, transformers, or radio transmitters) which causes electromagnetic or electrostatic interference.**
- (2) Deterioration of flowmeter circuit insulation occurs if the converter interior or cable ends get wet or humidified. This in turn causes **malfunction of flowmeter or noise problems.** **Avoid a rainy day if the flowmeter is to be installed outdoors.** Even indoors, prevent water from splashing over the flowmeter. Try to finish the wiring as quickly as possible
- (3) The converter has an arrestor installed inside. Therefore, **do not conduct a withstand voltage test for the converter.** To check the insulation of the converter, use a voltage of **250Vdc or less.**
- (4) After wiring, be sure to install the terminal block protection cover.
- (5) Because the excitation cable and flow rate signal cable transmit very delicate signals, pass each of them separately through a thick steel conduit tube, keep them away from the large current wiring as far as possible, and do not install them in parallel.

Separate

5.1 Cables

Use the kind of cables shown in Table 5.1 to wire the converter.

Table 5.1 Installation Cables

Name	Cable name	Nominal cross-sectional area	Finished outer diameter	Description
Power cable	3-core vinyl sheathed cable or 2-core vinyl sheathed cable	2 mm ²	11~13mm	CVV JIS C 3401 or equivalent
Output signal cable	The number of conductors the cable contains differs depending on the specification of the output signal cable. Use a shielded cable of finished outer diameter 11 to 13mm and nominal cross-sectional area 1.25mm ² .			CVV-S JIS -258-C or equivalent
Flow rate signal cable	2-core shielded chloroprene cabtyre cable (Rubber covered cable)	0.75 mm ²	11~13mm	2PNCT-S JIS C 3327 or equivalent
Excitation cable	3-core chloroprene cabtyre cable (Rubber covered cable)	2 mm ² 1.25 m ²	11~13mm	2PNCT JIS C 3327 or equivalent

Separate

Separate

5.2 External Device Connections and Grounding

For the notes on connecting, wiring and installation of the combined converter, check the model number of the combined converter and read the instruction manual of the relevant converter.

5.3 Notes on Wiring

5.3.1 Notes on Instrumentation-Converter Wiring

To avoid 2-point grounding, **ground the shield of output cable basically at the receiving side.**

Use a grounding wire of IV wire 5.5mm² or more. The size of the external grounding terminal screws is M4.

Do not share a grounding wire with other instruments where grounding current may flow. (An independent grounding is preferable.)

Power cable

When a 3-core cable is used: **Ground with the FG terminal.**

When a 2-core cable is used: Use an external grounding terminal and make the cable as short as possible.

5.3.2 Notes on Wiring of the Separate type (LF414)

Separate

The detector is shipped with a flow rate signal cable and excitation cable. Be sure to use those cables coming with the detector.

Note: When the cable length exceeds 300m, cables may not be supplied. Check whether the cable is supplied with the specs.

The allowable cable length between the detector and converter varies depending on the conductivity of the operating fluid. **Refer to the instruction manual of the combined detector.**

When connecting with the detector, wire the cables in the order of the excitation cable and flow rate signal cable.

Because the input cables transmit very delicate signals, pass the excitation cable and input signal cable **separately through a thick steel conduit tube, keep them away from the large current wiring as far as possible, and do not install them in parallel.**

When replacing the flow rate signal cable and excitation cable, also refer to the instruction manual of the relevant detector. Order the detector terminal box cover packing from Toshiba.

5.4 Wiring

5.4.1 Terminal Treatment of Cables

Follow the procedures below to treat the terminals (at the converter side) of various cables and install the cables to the terminal block. Use appropriate cables based on the description in Section 5.1 "Cables." Crimp a **round type insulated crimp-type terminal** to the end of the cables.

(1) Power cable, current output cable, digital I/O cables

The necessary cables should be ordered from the person responsible for the installation. Strip the sheath of each conductor as shown in Figure 5.1 and attach a crimping terminal with insulated sleeve to it. The size of the crimping terminal is as follows:

M4: Integral type LF600F and LF610F

M3.5: Integral type LF620F, Separate type LF602F, LF612F and LF622F

- Connect the power cable to terminal blocks L1 and L2.
- Connect the current output cable to terminal blocks + and -.
- Connect the digital I/O cable to terminal blocks D1, D01, D02 and COM, as required.

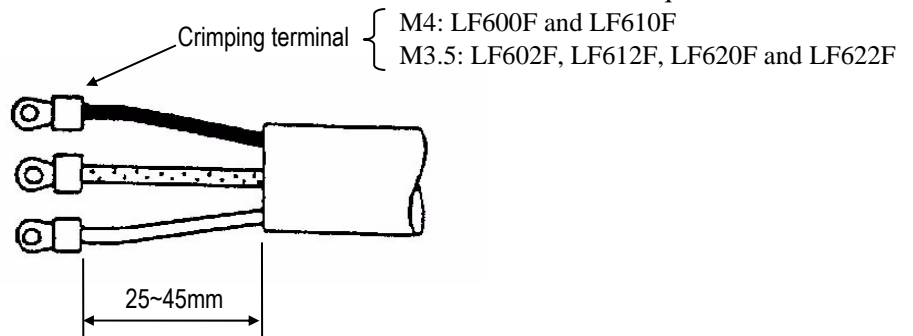

Figure 5.1 Terminal Treatment of Power Cable, Current Output Cable and Digital I/O cable

Separate

(2) Excitation cable

Strip the sheath from the end of each conductor as shown in Figure 5.2, attach an M3.5 crimping terminal with insulated sleeve, and connect it to the terminal blocks X and Y. Connect the red conductor to terminal block E.

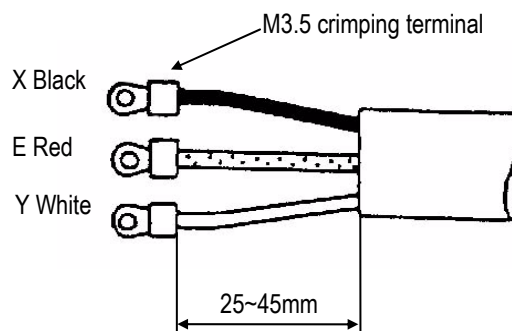

Figure 5.2 Terminal Treatment of Excitation Cable

(3) Connecting the input signal cable

Separate

Strip the sheath from the end of each conductor of a 2-core individually shielded cable as shown in Figure 5.4. Twist those shields and cover them with a thermal contraction tube or vinyl tube not to make contact with the case or core wires. Then attach an M3.5 crimping terminal with insulated sleeve as shown in Figure 5.3. Connect a crimping terminal to the A and B terminals on the terminal block and connect to each G terminal of the detector and converter.

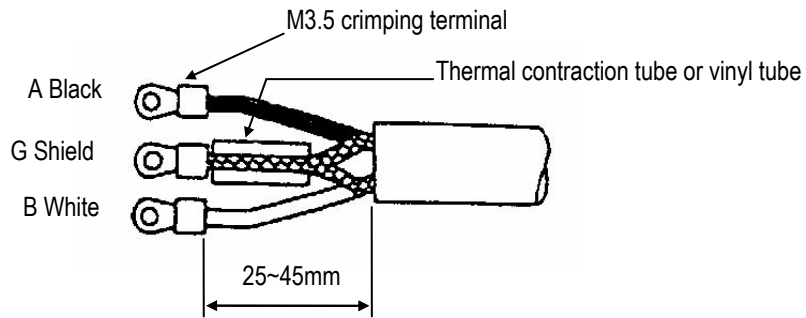
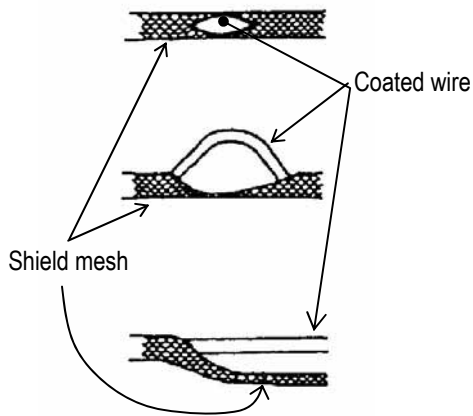

Figure 5.3 Terminal Treatment of Flow Rate Signal Cable

Notes on signal cable shield processing work

When stripping an external sheath, intermediate and insulated sheath, be careful not to scratch or cut the internal conductors and shield mesh. Do not disjoint the shield mesh but treat it as shown in Figure 5.9.



- a. Open the shield mesh with a pencil or the like.
- b. Pull out the internal coated wires from the hole of the shielded mesh.
- c. Pull out all internal coated wires and extend the shield mesh wire.

Figure 5.4 Treating the Signal Cable Shield Mesh

5.4.2 Cable Connection

Connect and install the terminal-treated cables to the terminal block.

*Connect the cables to the terminal block securely. A loose connection may cause incorrect measurement. After connecting a cable, try to pull it to check whether it has been connected securely.

Referring to **combined converter's manuals of "Connections and Grounding"**, connect each cable to the terminal block. **Tighten the screws of the terminal block tightly to ensure a secure connection.** A loose connection may cause incorrect measurement. **After connecting a cable, try to pull it to see whether it has been connected securely.**

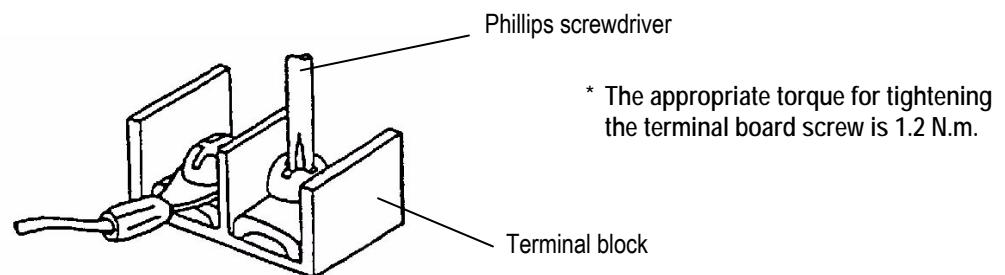





Figure 5.5 Connecting a Cable to Terminal Block

6. Operation

 CAUTION	
<ul style="list-style-type: none"> ■ Do not touch the terminal board when power is supplied. <div style="display: flex; align-items: center;">  <p>Touching the terminal board when power is supplied can cause electric shock.</p> </div> <p>DON'T</p>	<ul style="list-style-type: none"> ■ Do not touch the main body when high temperature fluid is being measured. <div style="display: flex; align-items: center;">  <p>The fluid raises the main body temperature and can cause burns.</p> </div> <p>DON'T</p>

Preparatory check

Follow the procedure described below to prepare before starting the flow measurement (described with regard to the entire flowmeter).

System Check

Check the items listed below

- Check **the wiring between the converter and related instruments.**
- Make sure **all the bolts of connection flanges on which the flowmeter** is mounted securely tightened.
- Make sure **the direction of flow arrow** is in accordance with actual flow.
- Make sure the flowmeter is **grounded** with 100 ohm or less ground resistance.
- Make sure the **housing covers** are securely tightened.

Placing System On-Stream

- **Let the fluid go through** the detector pipe. (Note 1)
- When the detector is filled with the fluid, **stop** the fluid and keep it still in the detector pipe.

Supplying Electric Power

- Make sure the **power supply** is as specified.

Checking Converter Parameters

- Check the configuration parameter settings. **Refer to combined converter's manual.**

Zero Adjustment

- Wait for 30 minutes to warm up the flowmeter. Then making sure the fluid holds still in the detector pipe, starts the **zero adjustment**. Refer to **combined converter's manual**.







On-line measurement



- After checking the items and conducting the zero adjustment as listed above, let the fluid go through the detector pipe. Output (4–20 mA dc) directly proportional to the flow rate can be obtained.

Note 1: If the detector pipe is not filled with the fluid to be measured, the flow rate will be indefinite and unable to be measured. Before using the flowmeter, be sure to fill the detector pipe the fluid to be measured.

7. Maintenance and Troubleshooting

Safety precaution for Maintenance and Troubleshooting

 WARNING	
<p>■ Do not disconnect while circuit is live unless location is known to be nonhazardous.</p> <p> DON'T</p>	<p>Live part of electric circuit or a high temperature department can cause explosion.</p>
<p>■ Do not modify or disassemble the enclosure.</p> <p> DON'T</p>	<p>Strength degradation and defects of enclosure can cause explosion.</p>
<p>■ Do not use parts of other products.</p> <p> DON'T</p>	<p>Protective performance degradation for hazardous location can cause explosion.</p>
<p>■ Do not live circuits While assembly of all components is not over.</p> <p> DON'T</p>	<p>Protective performance degradation for hazardous location can cause explosion.</p>
<p>■ Install per the National Electrical Code for the US (NEC, ANSI/NFPA 70) and the Canadian Electrical code for Canada (CEC, CAN/CSA-C22.1) and the drawing 3S8A2532, 3S8A2676 and 3S8A2677 (Refer to Appendix 1).</p>	
<p> DO</p>	<p>Unsuitable conduit connections for hazardous location can cause explosion.</p>

 CAUTION	
<p>■ Do not conduct wiring work when power is applied.</p> <p> DON'T</p>	<p>Wiring while power is applied can cause electric shock.</p>
<p>■ Do not touch the LF414/LF600F, LF414/LF610F, LF414/LF620F and LF414 main body when high temperature fluid is being measured.</p> <p> DON'T</p>	<p>The fluid raises the main body temperature and can cause burns.</p>

7.1 Maintenance

■ Cleaning

■ Adhesion might be created in the detector over a long period of time when used on certain materials.

Try to confirm whether to cause the adhesion in the detector pipe when the phenomenon is seen, and an abnormality (ex. decreasing indication, etc.) is confirmed.

Please clean with a soft brush etc. and remove any unnecessary build up inside the meter. When using it in the line to which such a phenomenon occurs easily, it is recommended that the detector pipe be cleaned regularly.

Use new gaskets when reinstalling the flowmeter detector in the pipeline.

■ Mag-Prover Built-In Calibrator

The converter has a built-in reference signal calibration and verification circuit that allows you to re-verify the original magmeter flow lab calibration without the need for external devices. **This reference signal can be used to check the zero and span of the converter for the purpose of instrumentation maintenance or periodical inspection. Refer to combined converter's manual.**

■ Operative life

The operative life of this flowmeter is **10 years** from the date of shipment.

The life of the flowmeter differs depending on the environmental conditions and the way it was used. To extend the life of the flowmeter, **inspect the flowmeter periodically and clean or replace components** if necessary.

■ Product disposal

The electromagnetic flowmeter must be disposed of, according to the rules and regulations of your local government.

Especially if you dispose of electrolytic capacitors to replace parts, have it done by an agency which is licensed to handle industry waste materials.

■ Check/Replacement of the display unit

Integral

When characters displayed on the LCD display become thin or blots come out, please adjust the setting of LCD's display density. If the display is still not improved, the display unit comes to **the end of its life. Please replace the display unit with a new one.** In order to use the display unit stably for a long time, it is preferable to replace it early. For inspection and replacement, **please contact your nearest Toshiba representative.**

■ Power supply unit (also used for excitation board)

Integral

Electronic components **deteriorate faster when the ambient temperature is high.** The life of the power supply unit in the converter is **9 to 10 years** if the ambient temperature is 40°C, and **5 to 6 years** if it is 50° C. To extend the life of the flowmeter, we recommend you **replace the power supply unit early.**

Contact your nearest Toshiba representative for a flowmeter inspection or unit replacement.

7.2 Troubleshooting

If a problem occurs while using the LF414/LF600F, LF414/LF610F, LF414/LF620F and LF414, follow the flowcharts described below.

You may find a way to solve the problem. The flowcharts are based on three symptoms (1) to (3).

If you cannot solve the problem, contact your nearest Toshiba representative.

7.2.1 Flow rate is not indicated

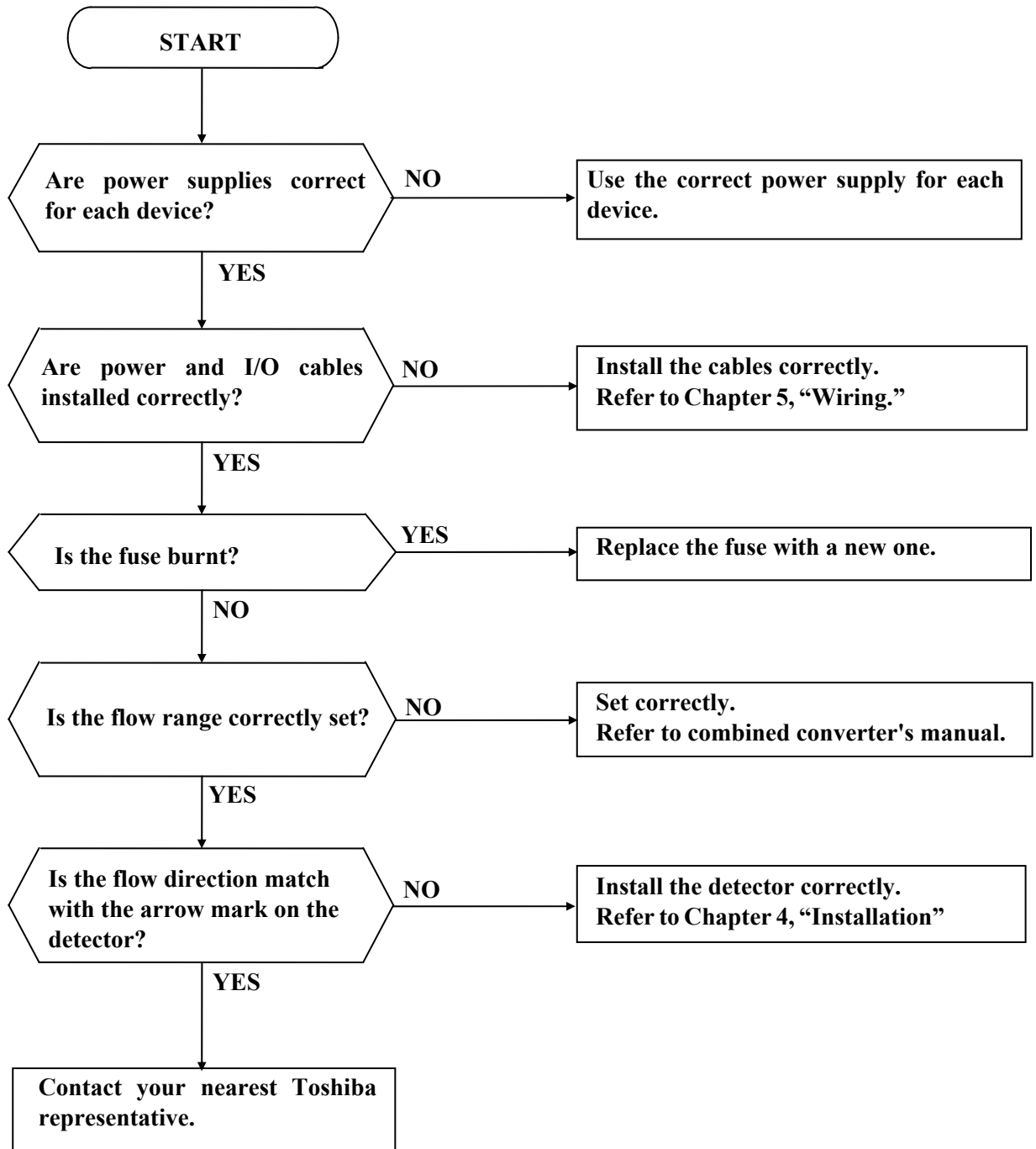

7.2.2 Flow rate indicated is not correct

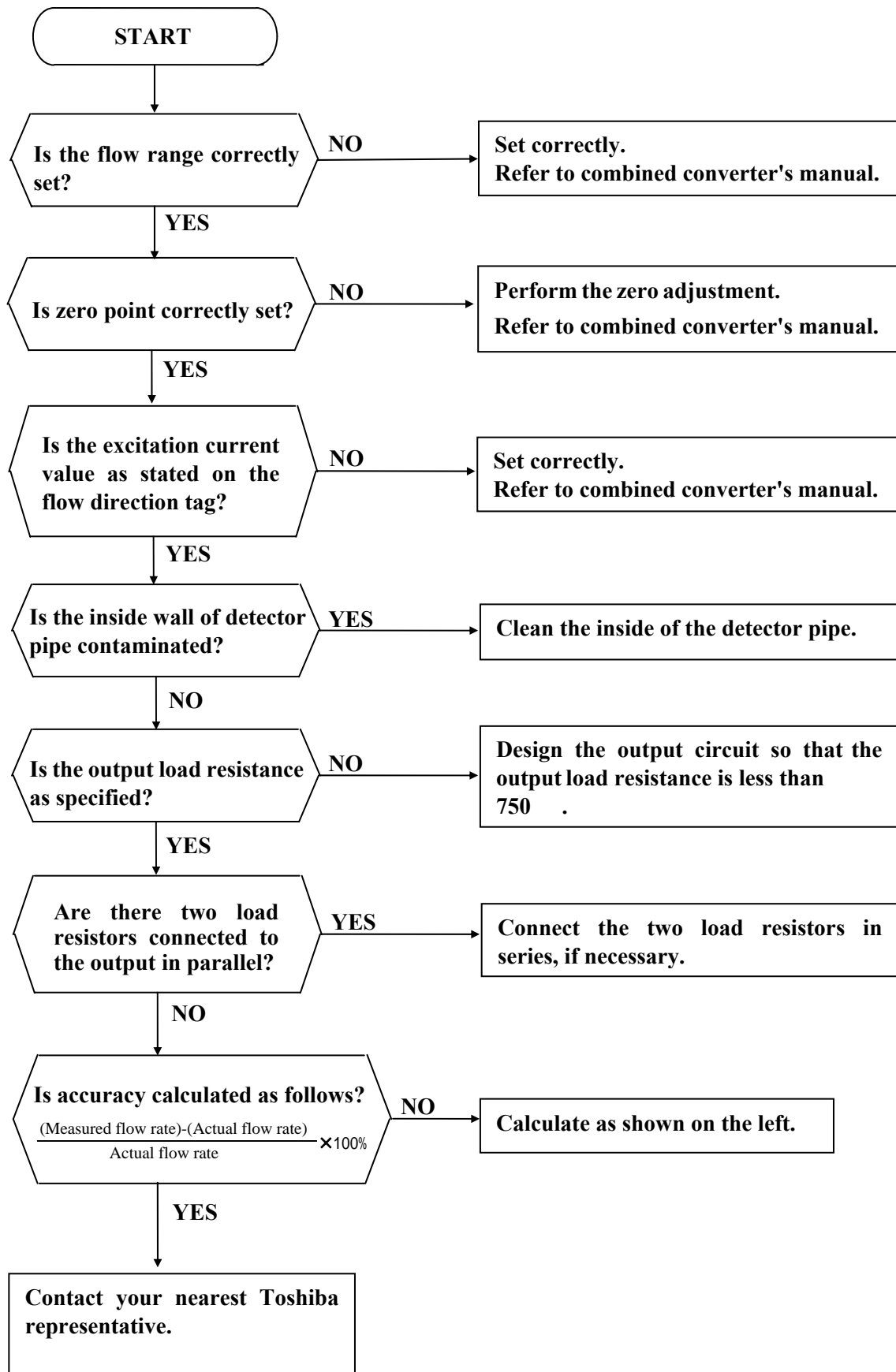

7.2.3 Flow rate indication is not stable

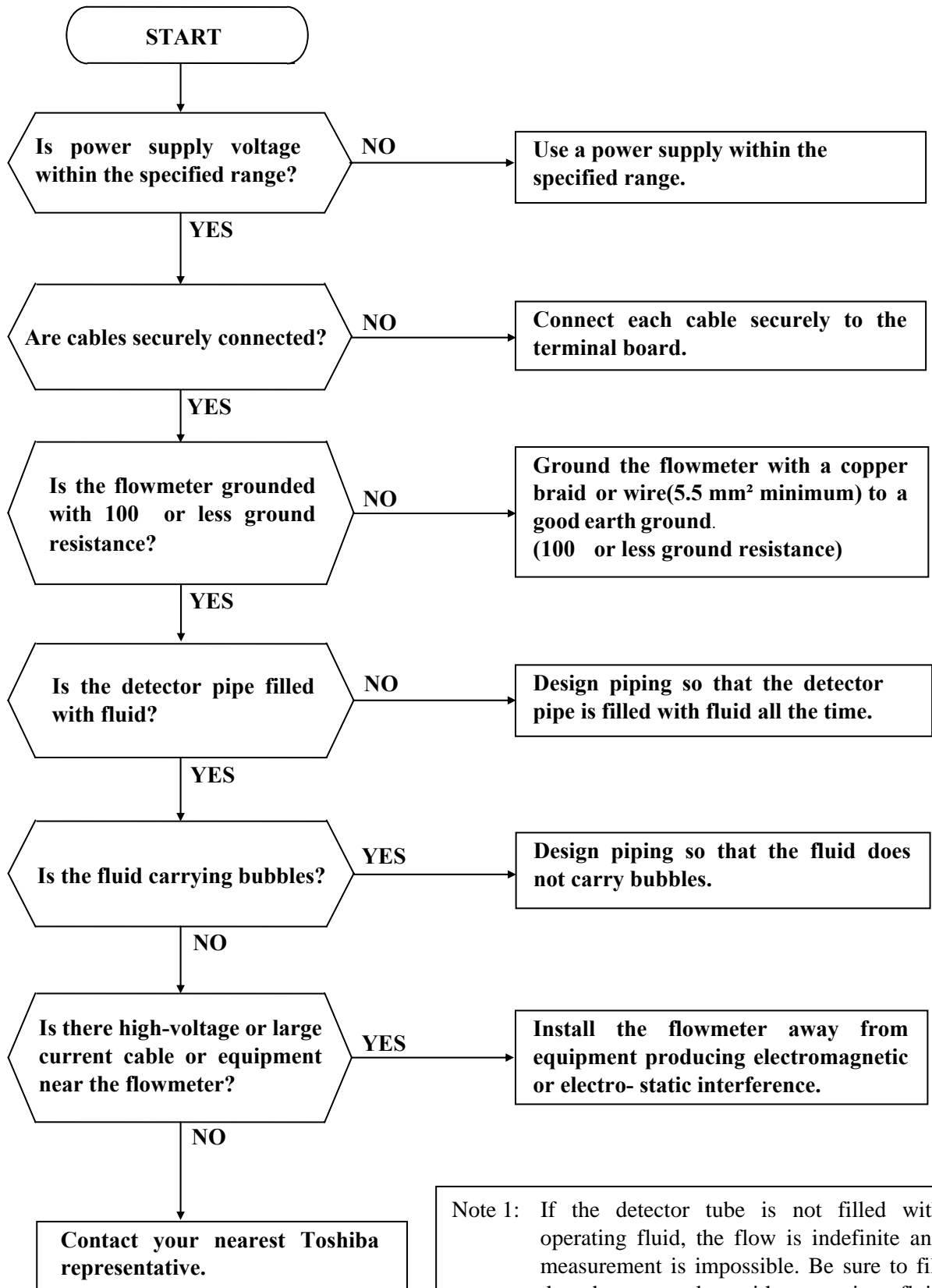

Note 1: If the detector tube is not filled with operating fluid, the flow is indefinite and measurement is impossible. Be sure to fill the detector tube with operating fluid before starting measurement.

8. Principle of Operation

The operating principle of the electromagnetic flowmeter is based on Faraday's Law of electromagnetic induction and it is designed to measure the volumetric flow rate of fluid. An insulated pipe of diameter D is placed vertically to the direction of a magnetic field with flux density B (see Figure 8.1). When an electrically conductive fluid flows in the pipe, an electrode voltage E is induced between a pair of electrodes placed at right angles to the direction of magnetic field. The electrode voltage E is directly proportional to the average fluid velocity V .

The following expression is applicable to the voltage.

$$E = K \times B \times D \times V \text{ [V] (Eq. 8.1)}$$

Volumetric flow rate Q [m^3/s] is:

$$Q = \frac{\pi \times D^2}{4} \times V \text{(Eq. 8.2)}$$

Using the Equation 14.1 and 14.2

$$E = K \times B \times D \times \frac{4}{\pi \times D^2} \times Q$$

$$E = \frac{4 \times K \times B}{\pi \times D} \times Q \text{(Eq. 8.3)}$$

Therefore, volumetric flow rate is directly proportional to the induced voltage.

E = induced electrode voltage [V]

K = constant

B = magnetic flux density [T]

D = meter pipe diameter [m]

V = fluid velocity [m/s]

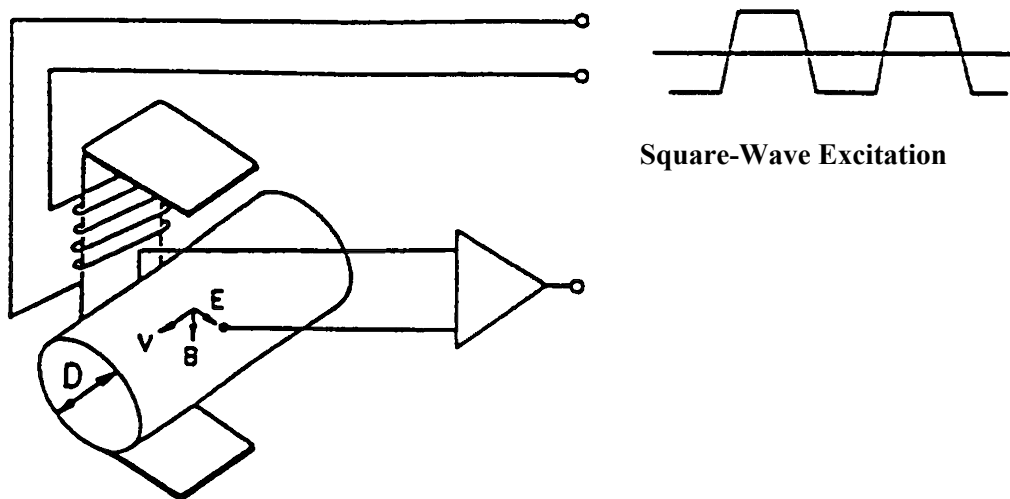

Figure 8.1 Principle of Operation

The LF414/LF600F, LF414/LF610F, LF414/LF620F and LF414 uses the square-wave excitation method, which provides long-term stable operation. With square-wave excitation, the LF414/LF600F, LF414/LF610F, LF414/LF620F and LF414 offers reliable measurement without being affected by electrostatic or electromagnetic interference, or electrochemical polarization between the electrodes and the fluid to be measured.

9. Specifications

The flowmeter specifications and the type specification code used when ordering the flowmeter are described in this chapter.

9.1 Specifications

Meter size: 1/2, 1, 1 1/2, 2, 3, 4, 6, 8 inch
(15, 25, 40, 50, 80, 100, 150, 200mm)

Measurement range in terms of flow velocity:

0 – 1.0 ft/s to 0 – 32.8 ft/s (0 – 0.3 m/s to 0 – 10 m/s).

0 – 0.3 ft/s to 0 – 1.0 ft/s (0 – 0.1 m/s to 0 – 0.3 m/s) range is available optionally.

System accuracy combined with TOSHIBA converter:

Accuracy: $\pm 0.2\%$ of Rate*

* This pulse output error result is established under standard operating conditions at Toshiba's flow calibration facility, Fuchu Japan. (NIST Traceable).

* Individual meter measurement error may vary up to $\pm 0.5\%$ of Rate at 1.64 ft/s (0.5m/s) or more and $\pm 0.3\%$ of rate ± 0.039 inch/s (1mm/s) at 1.64 ft/s (0.5m/s) or less.

* Current output: plus $\pm 8\mu\text{A}$ (0.05% of span.)

* Refer to individual calibration data for each individual meter's measurement error.

Fluid conductivity: 5 $\mu\text{S/cm}$ minimum

Fluid temperature: 14 to 356 °F (–10 to +180 °C) (Ceramic Tube detector)
(248 °F (120 °C) above is separate type)

14 to 248 °F (–10 to +120 °C) (Teflon PFA Lining detector)

Ambient temperature: –4 to 140°F (–20 to +60 °C)

Fluid pressure: –15 to 300psi, or –1.0 to 20 bar (–0.1 to 2.0MPa)

Heat shock resistance: for ceramic tube detector

Heating: T 302 °F / 0.5 s (150 °C / 0.5 s) **(Note)**

Cooling: T 212 °F / 0.5 s (100 °C / 0.5 s) **(Note)**

Note: Meaning that the ceramic tube detector withstands the shock of sudden heating (temperature difference 302 °F (150 °C) or less per 0.5 seconds) or sudden cooling (temperature difference 212 °F (100 °C) or less per 0.5 seconds).

Connection flange standard: See Table 9.3 Type Specification Code.

Principal materials

Case • • • • • Stainless steel : meter sizes 1" to 4" (25 to 100 mm)
Carbon steel : meter size 1/2", 6" and 8" (15 mm, 150mm, and 200mm)

Lining • • • • • Ceramic : standard for meter sizes 1/2" to 4" (15 to 100 mm)

Teflon PFA : standard for meter sizes 6" and 8" (150 mm, 200mm)

Electrodes • • • • • 316L stainless steel (standard)

Grounding rings • • 316 stainless steel (standard)

See Table 9.3 Type Specification Code for optional materials and other related information.

Coating: No coating
 (for meter sizes 1" to 4" (25 to 100 mm)),
 Phthalic acid resin coating, pearl-gray colored
 (standard for meter size 1/2", 6", 8" (15,150, 200mm))

Structure: IP67 and NEMA 4X Watertight (Standard)

Separate Cable connection port: 3/4-14NPT male screw for both signal cable and exciting cable

Separate Cable length: Allowable cable length between the converter and the detector varies with the electrical conductivity of fluid. See Figure 9.1

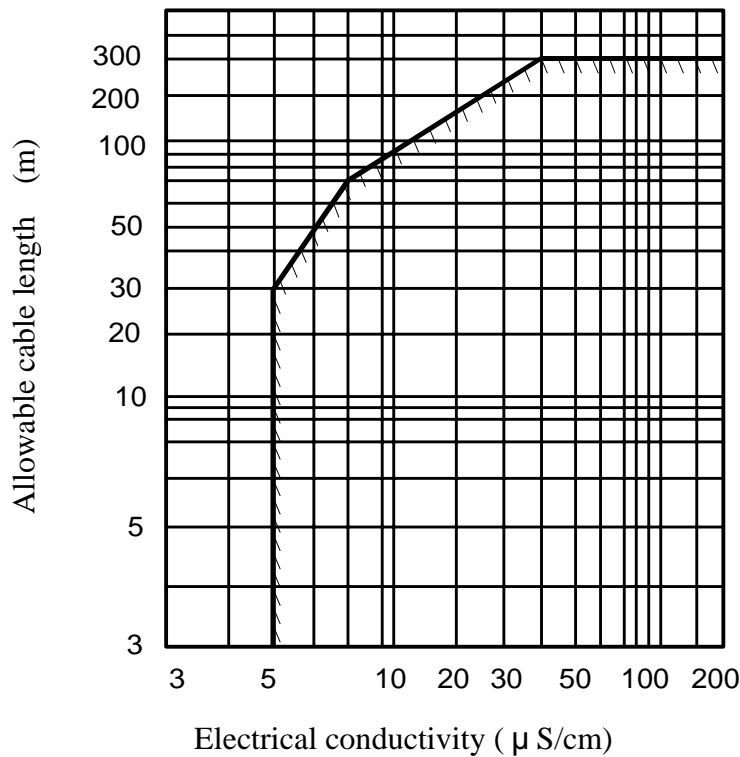

Figure 9.1 Electrical Conductivity vs. Cable Length

Flow and calibration velocity range:

It calibration by standard Range shown in the table below when Range is not specified.
 It calibration when there is specification by flowing quantity Range in which the customer is specified. Is this specification Range flowing quantity of Table 9.1. Please confirm becoming in the upper bound value from the flow velocity chart.

Table 9.1 Standard Flow Range

Meter size Inch (mm)	Standard flow range		
	Flow rate (gal/min)	Flow rate (m ³ /h)	Flow velocity (m/s)
1/2 (15)	25	2	3.144
1 (25)	75	6	3.395
1 1/2 (40)	175	15	3.316
2 (50)	300	25	3.537
3 (80)	650	60	3.316
4 (100)	1,000	100	3.537
6 (150)	2,500	200	3.144
8 (200)	4,500	300	2.653

Note: The unit of "gal/min" is not exchanged (converted) by "m³/h"

To select the meter size: See Table 9.2 to find meter sizes within the velocity of 0.3 to 32.8 ft/s (0.1 to 10m/s) for a specified full-scale (measuring range high limit) flow. Select one that has its full-scale velocity between 3.0 and 10 ft/s (1 and 3m/s).

Note: Make sure the full-scale flow rate used for the final planning stage stays within 32.8 ft/s (10m/s) in terms of flow velocity.

Table 9.2 Flow velocity vs. flow volume

Unit: gal/min

Size (inch)	Flow rate				
	0.3 ft/s	0.98 ft/s	3.0ft/s	10 ft/s	32.8 ft/s
1/2"	0.2778	0.8403	2.561	8.532	28.01
1"	0.7780	2.334	7.115	23.72	77.81
1 1/2"	1.991	5.975	18.210	60.71	199.2
2"	3.112	9.337	28.460	94.86	311.2
3"	7.965	23.90	72.850	242.8	796.7
4"	12.45	37.35	113.8	379.4	1,245
6"	28.01	84.03	256.1	853.8	2,801
8"	49.80	149.4	455.3	1,518	4,980

Unit: m3/h

Size (mm)	Flow rate				
	0.1m/s	0.3m/s	1m/s	3m/s	10m/s
15	0.0631	0.1908	0.6361	1.908	6.361
25	0.1767	0.5301	1.767	5.301	17.67
40	0.4523	1.357	4.523	13.57	45.23
50	0.7067	2.120	7.067	21.20	70.67
80	1.809	5.428	18.09	54.28	180.9
100	2.827	8.482	28.27	84.82	282.7
150	6.361	19.08	63.61	190.8	636.1
200	11.31	33.93	113.1	229.3	1,131

9.2 Type Specification Code

Table 9.3 Type Specification Code

Specification Code														Description	1/2" to 4"	6" and 8"	
1	2	3	4	5	6	7	8	9	10	11	12	13	14				
L	F	4													Electromagnetic Flowmeter		
			1												Style Wafer type		
				4											Area of use Division 2 Hazardous Location		
					D										Meter size 1/2" (15mm) 1" (25mm) 1-1/2" (40mm) 2" (50mm) 3" (80mm) 4" (100mm) 6" (150mm) 8" (200mm)		
					E										Mounting Structure Hazardous location cFMus, Division 2 approved Detector/Converter combined type Detector/Converter separate type		
					F												
					G										Connection flange standard ASME B 16.5 class 150 ASME B 16.5 class 300 EN 1092-1 PN10 EN 1092-1 PN16 JIS B 2220 10K JIS B 2220 16K JIS B 2220 20K		
					H												
					J										Electrode Material 316L stainless steel Ti (titanium) Pt-Ir (platinum/iridium) Ta (tantalum) Hastelloy C		
					K												
					L										Lining Material Alkali-resistant ceramic (alumina) (standard) Acid-resistant ceramic (alumina) Teflon PFA		
															Grounding Ring Material 316 stainless steel 316L stainless steel Ti (titanium) Ta (tantalum) Pt-Ir (platinum/iridium) Hastelloy C		
															Flow and calibration velocity range 1.0 to 32.8 ft/s (0.3 to 10 m/s) (standard range calibration) 1.0 to 32.8 ft/s (0.3 to 10 m/s) (specified range calibration) 0.3 to 32.8 ft/s (0.1 to 10 m/s) (specified range calibration)		
															Excitation and Signal Cables not provided 30m cable, provided other lengths, provided		
															Coating no coating (Standard for meter size 1" to 4") phthalic acid resin coating pearl-gray colored (Standard for meter size 1/2", 6" and 8") black tar epoxy resin, thickness 0.3 mm black tar epoxy resin, thickness 0.5 mm		

: Standard : Option - : Not available

Table 9.4 Type Specification Code (Exciting Cable and Signal Cable)

Model			Specification Code					Description
1	2	3	4	5	6	7	8	
A	C	C						Dedicated preformed cable
			A					Nominal cross-sectional area of Exciting cable (Note 1) 1.25 mm ²
			B					2 mm ²
				A				Nominal cross-sectional area of Signal cable (Note 2) 0.75 mm ²
								Cable length
					0	0	1	1 m
					0	0	2	2 m
					0	0	3	3 m
					0	0	4	4 m
					0	0	5	5 m
					0	0	6	6 m
					0	0	7	7 m
					0	0	8	8 m
					0	0	9	9 m
					0	1	0	10 m
					0	1	5	15 m
					0	2	0	20 m
					0	2	5	25 m
					0	3	0	30 m
					0	3	5	35 m
					0	4	0	40 m
					0	4	5	45 m
					0	5	0	50 m
					0	6	0	60 m
					3	0	0	300 m

From 1 to 10 meters (3.3 to 32.8 feet),
Cable can be ordered in 1 meter increments.

From 10 to 50 meters (32.8 to 164 feet),
cable can be ordered in 5 meters increments.

From 50 to 300 meters (164 to 984 feet),
cable can be ordered in 10 meters increments.

Notes:

- Exciting cable is a 3-wire chloroprene sheathed cable. For a nominal cross-sectional area of 1.25 mm², the overall diameter will be 12 mm (15/32 inch); for 2 mm², 13 mm(1/2 inch).
- Signal cable is a 2-wire shielded chloroprene sheathed cable with a nominal cross-sectional area of 0.75 mm² and an overall diameter of 12 mm (15/32 inch).
- Relation between exciting cable length and its nominal cross-sectional area and overall diameter is as follows.

Exciting cable length	Nominal cross-sectional area	Overall diameter
1 to 200 m	1.25 mm ²	12 mm
210 to 300 m	2 mm ²	13 mm

10. Outline Dimensions

10.1 Outline dimensions of LF414/LF600F, LF414/LF610F

Integral

(1) Meter size of 1/2 inch (15mm)

Unit : inch (mm)

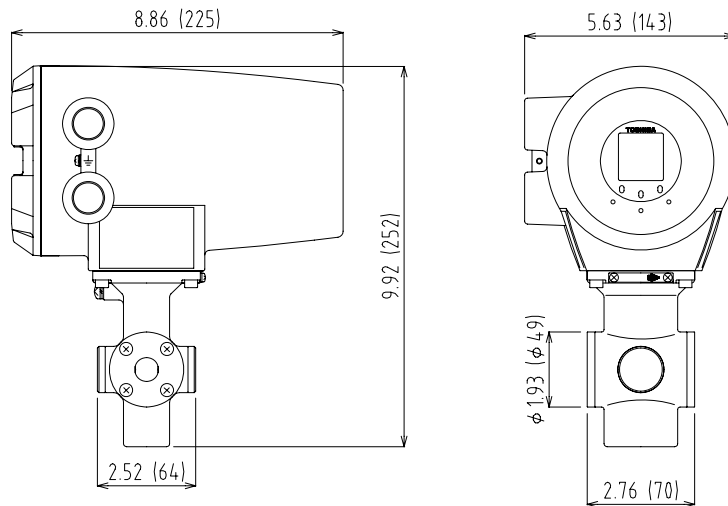

Waight : approx 11lb (5kg)

(2) Meter size of 1 inch (25mm)

Unit : inch (mm)

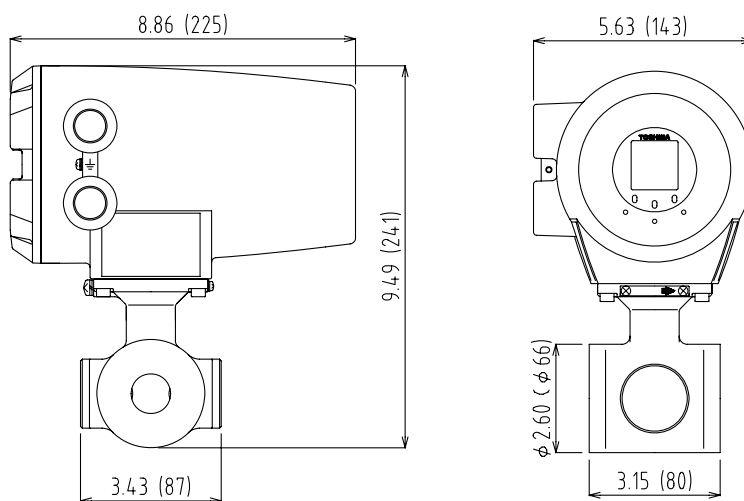

Waight : approx 11lb (5kg)

(3) Meter size of 1 1/2 to 8 inch (40 to 200mm)

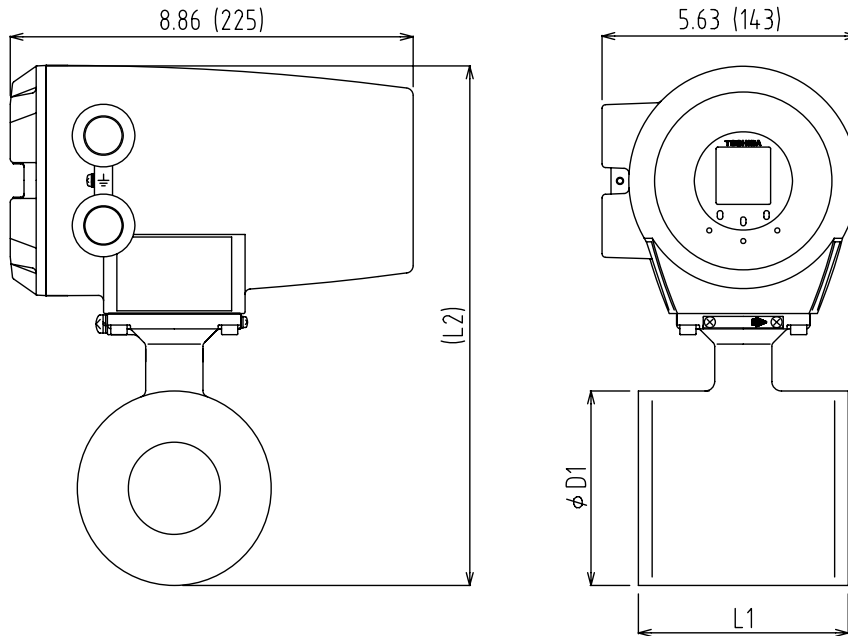

Unit : inch (mm)

Meter size inch (mm)	Overall length L1	Hight (L2)	Diamete of flange D1	Weight lb (kg)
1-1/2 (40)	3.94 (100)	10.39 (264)	3.35 (85)	approx 14 (6)
2 (50)	4.33 (110)	11.02 (280)	4.02 (102)	approx 16 (7)
3 (80)	4.33 (110)	12.05 (306)	5.00 (127)	approx 18 (8)
4 (100)	4.72 (120)	13.31 (338)	6.26 (159)	approx 22 (10)
6 (150)	9.06 (230)	16.02 (407)	8.50 (216)	approx 49 (22)
8 (200)	11.81 (300)	18.03 (458)	10.51 (267)	approx 79 (36)

10.2 Outline dimensions of LF414/LF620F

Integral

(1) Meter size of 1/2 inch (15mm)

Unit : inch (mm)

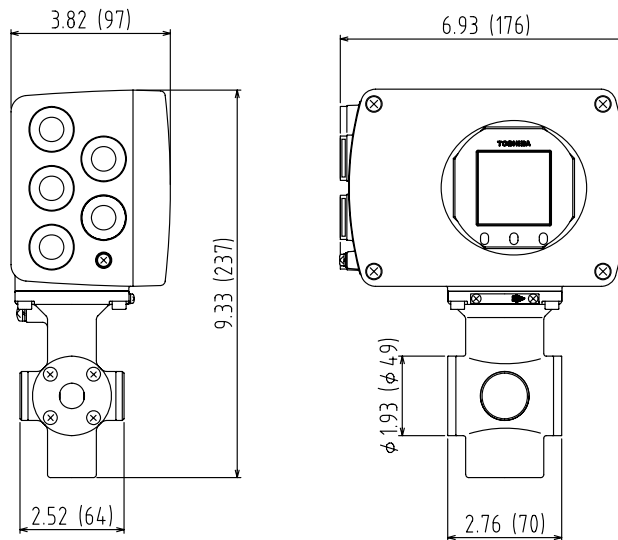

Waight : approx 9 lb (4kg)

(2) Meter size of 1 inch (25mm)

Unit : inch (mm)

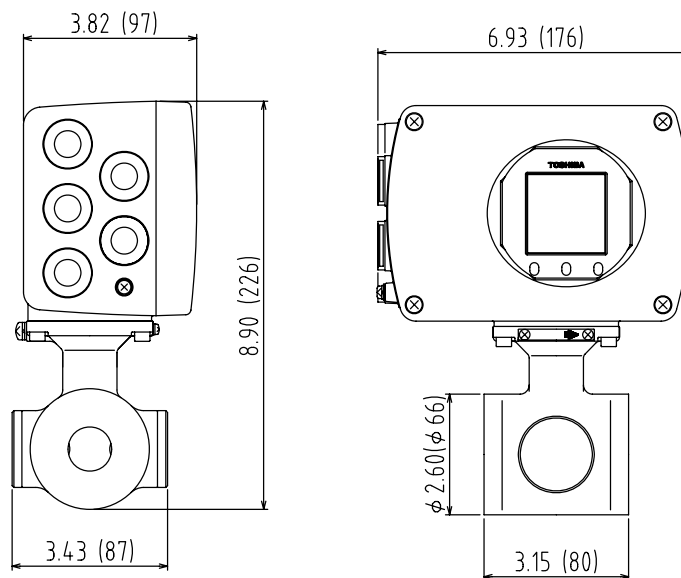

Waight : approx 9 lb (4kg)

(3) Meter size of 1 1/2 to 8 inch (40 to 200mm)

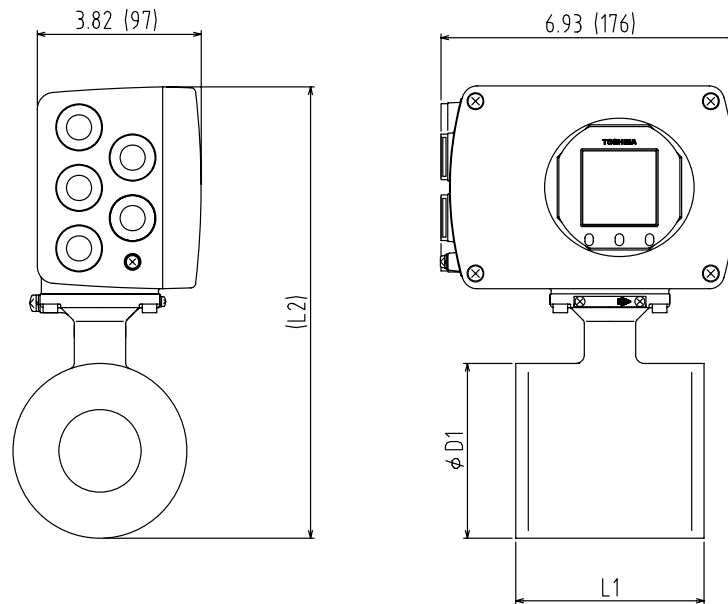

Unit : inch (mm)

Meter size inch (mm)	Overall length L1	Hight (L2)	Diamete of flange D1	Weight lb (kg)
1-1/2 (40)	3.94 (100)	9.80 (249)	3.35 (85)	approx 11 (5)
2 (50)	4.33 (110)	10.43 (265)	4.02 (102)	approx 14 (6)
3 (80)	4.33 (110)	11.46 (291)	5.00 (127)	approx 16 (7)
4 (100)	4.72 (120)	12.72 (323)	6.26 (159)	approx 20 (9)
6 (150)	9.06 (230)	15.43 (392)	8.50 (216)	approx 47 (21)
8 (200)	11.81 (300)	17.44 (443)	10.51 (267)	approx 77 (35)

10.3 Outline dimensions of LF414

Separate

(1) Meter size of 1/2 inch (15mm)

Unit : inch (mm)

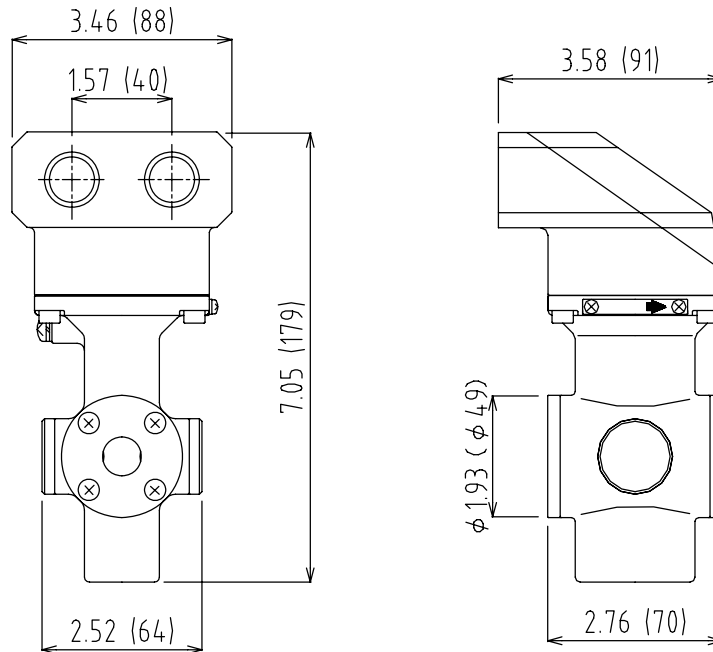

Waigt : approx 7 lb (3kg)

(2) Meter size of 1inch (25mm)

Unit : inch (mm)

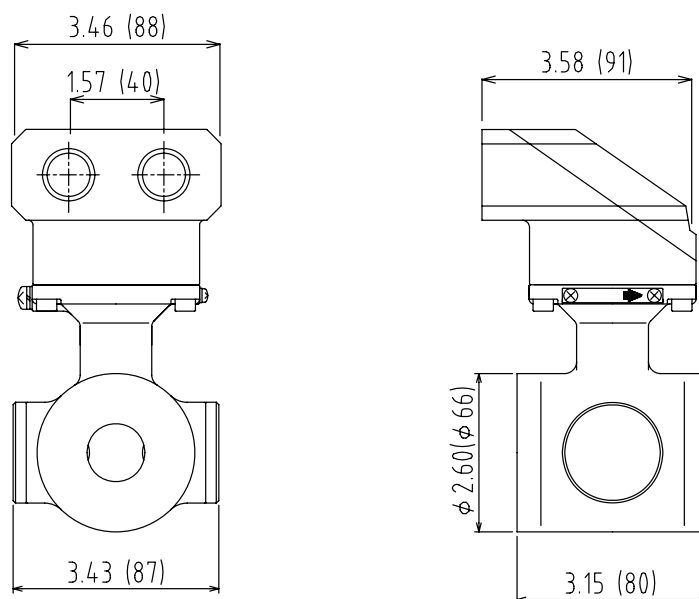

Waigt : approx 7 lb (3kg)

(3) Meter size of 1 1/2 to 8 inch (40 to 200mm)

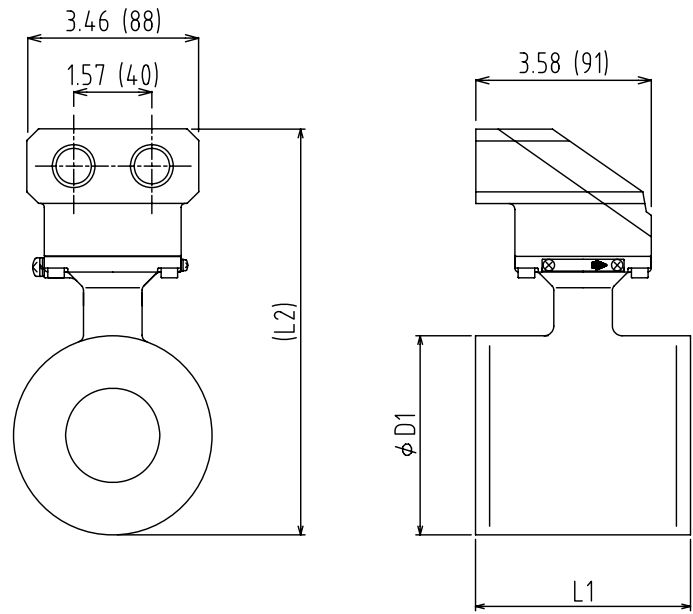

Unit : inch (mm)

Meter size inch (mm)	Overall length L1	Hight (L2)	Diamete of flange D1	Weight lb (kg)
1-1/2 (40)	3.94 (100)	7.48 (190.5)	3.35 (85)	approx 8 (4)
2 (50)	4.33 (110)	8.15 (207.1)	4.02 (102)	approx 10 (5)
3 (80)	4.33 (110)	9.13 (232.5)	5.00 (127)	approx 12 (6)
4 (100)	4.72 (120)	10.39 (264.5)	6.26 (159)	approx 18 (9)
6 (150)	9.06 (230)	13.15 (334.0)	8.50 (216)	approx 44 (21)
8 (200)	11.81 (300)	15.16 (385.0)	10.51 (267)	approx 66 (30)

Appendix 1

1-1 A system block diagram for LF414/LF600F, LF414/LF610F

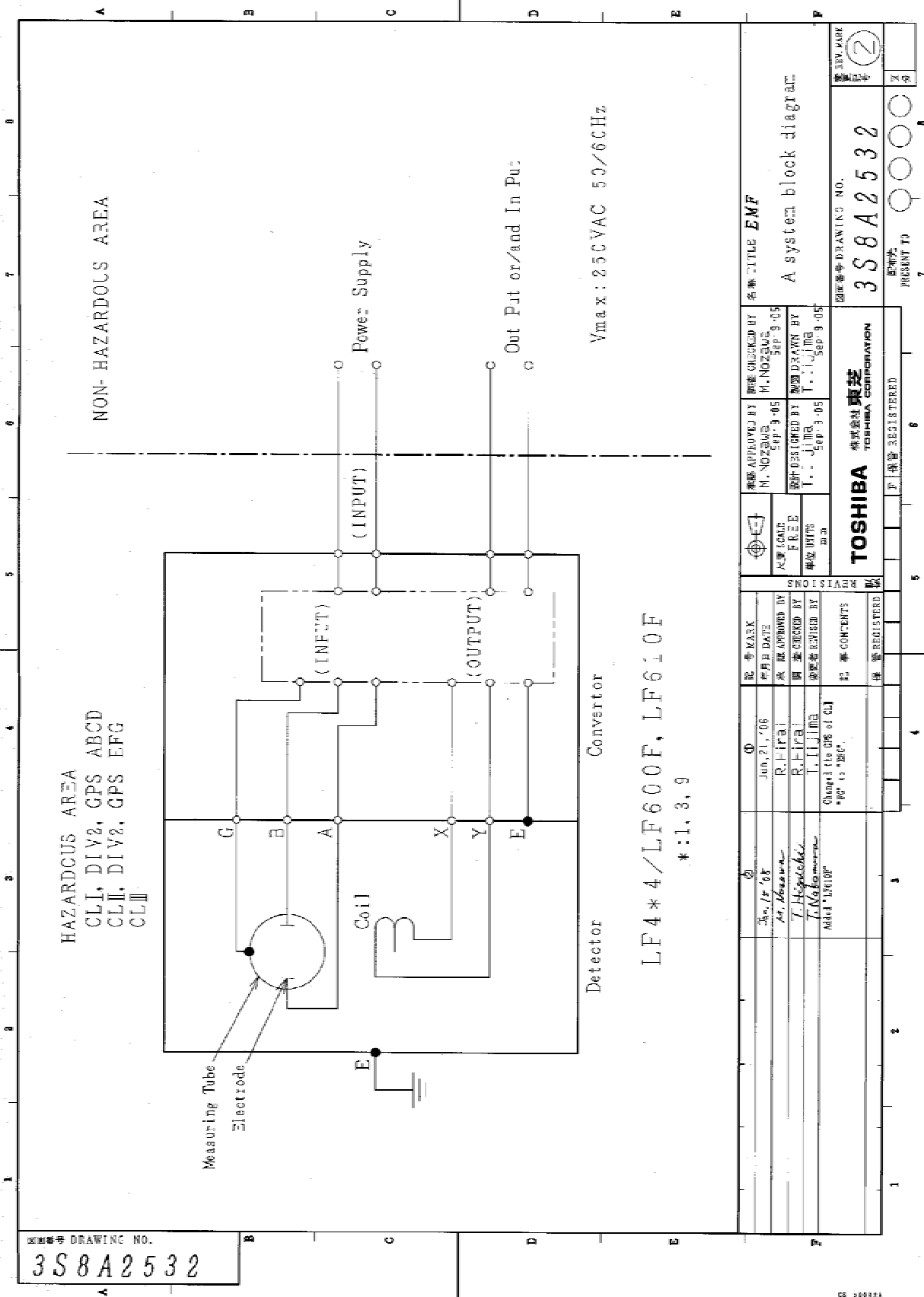

1-2 A system block diagram for LF414/LF620F

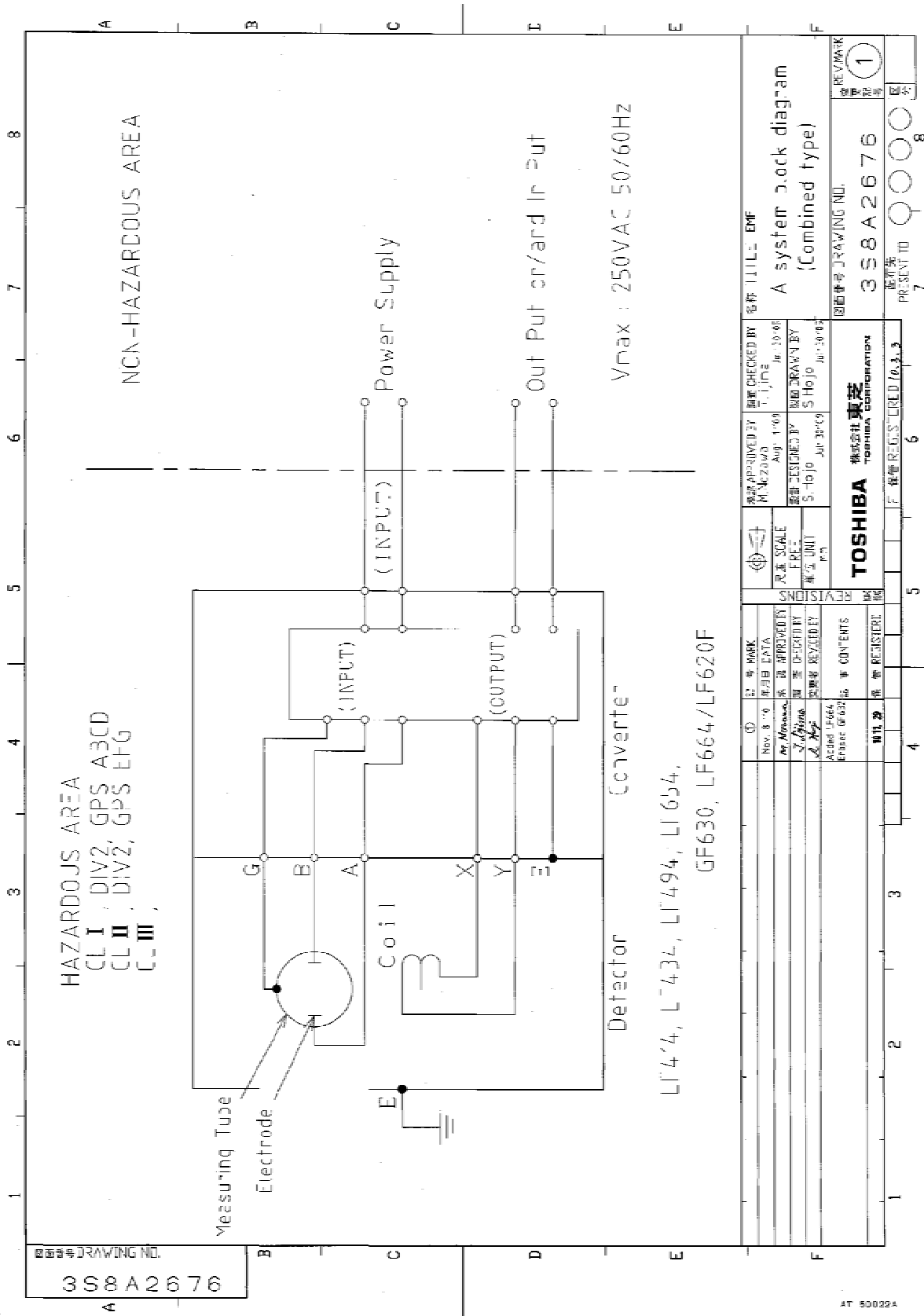

AT 500224

2-1 A system block diagram for LF414

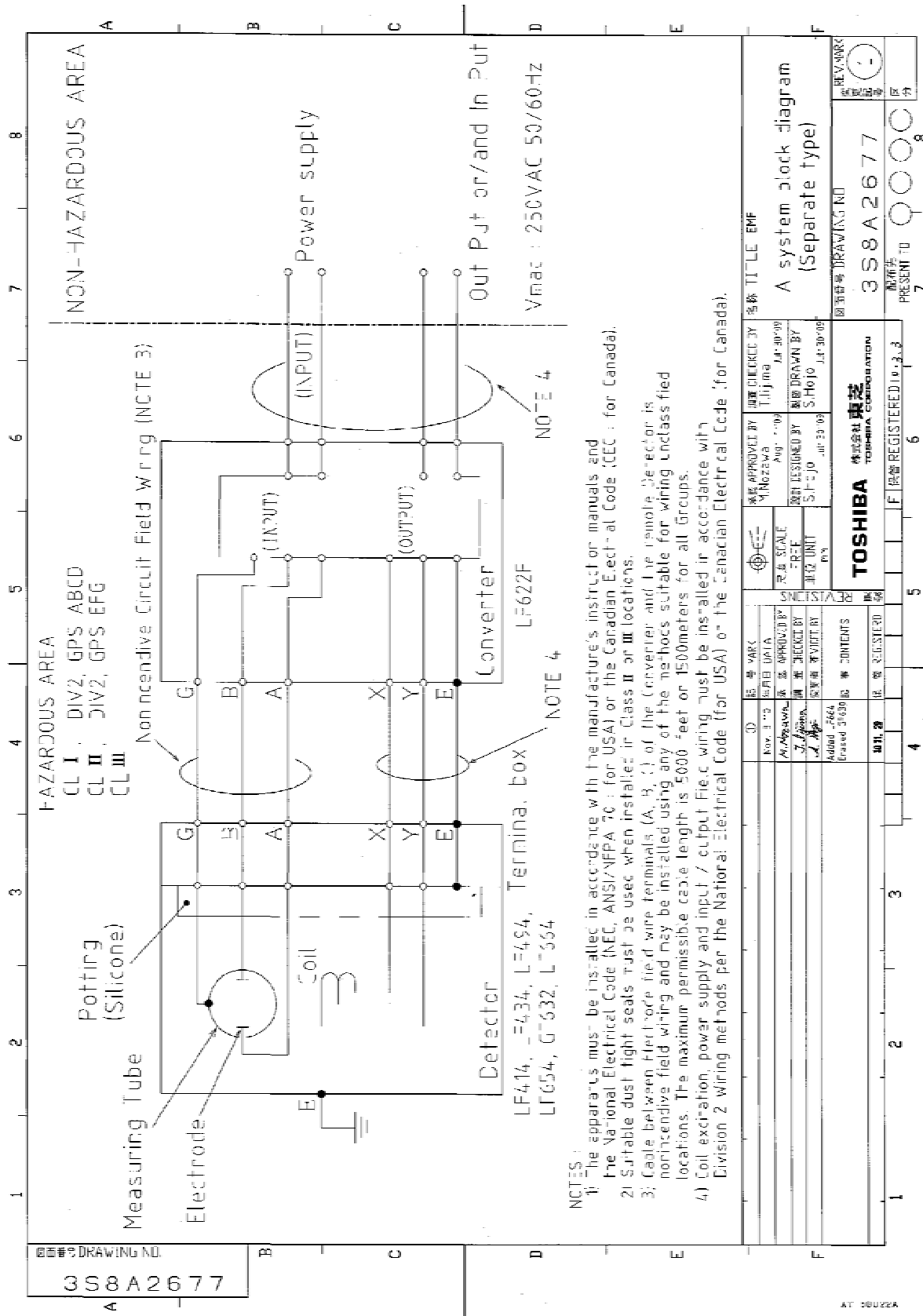

- NOTES:
- The apparatus must be installed in accordance with the manufacturer's instruction manuals and the National Electrical Code (NEC, ANSI/NFPA 70 : for USA) or the Canadian Electrical Code (CEC : for Canada).
 - Suitable dust tight seals must be used when installed in Class II or III locations.
 - Cable between Hart core field wire terminals (A, B, C) of the Converter and the remote Detector is noninductive field wiring and may be installed using any of the methods suitable for wiring Unclass field locations. The maximum permissible cable length is 5000 feet or 1500meters for all Groups.
 - Coil excitation, power supply and input / output Field wiring must be installed in accordance with Division 2 wiring methods per the National Electrical Code (for USA) or the Canadian Electrical Code (for Canada).

Write down the address and phone number of the distributor from which you purchased this product, the product code, SER.NO. and so on.

Distributor	Address _____
	Name _____
	Phone number () -
Product code	<u>LF</u> _____
SER.NO.	_____

TOSHIBA CORPORATION

Free Manuals Download Website

<http://myh66.com>

<http://usermanuals.us>

<http://www.somanuals.com>

<http://www.4manuals.cc>

<http://www.manual-lib.com>

<http://www.404manual.com>

<http://www.luxmanual.com>

<http://aubethermostatmanual.com>

Golf course search by state

<http://golfingnear.com>

Email search by domain

<http://emailbydomain.com>

Auto manuals search

<http://auto.somanuals.com>

TV manuals search

<http://tv.somanuals.com>