

G8000 SERIES

INSTALLATION and OPERATION MANUAL

480/480 V 80/100/125/150/225/300/500 kW



Document: 61001-002
April 2013

G8000 SERIES

INSTALLATION and OPERATION MANUAL

480/480 V 80/100/125/150/225/300/500 kW

Document: 61001-002

April 2013



The Toshiba products listed in this document are intended for usage in general electronics applications (computer, personal equipment, office equipment, measuring equipment, industrial robotics, domestic appliances, etc.). These Toshiba products are neither intended nor warranted for usage in equipment that requires extraordinarily high quality and/or reliability; nor are they intended to be used in equipment that, if a malfunction or failure occurs, may result in loss of human life or bodily injury (collectively referred to as "Unintended Usage"). Unintended Usage includes atomic energy control instruments, airplane or spaceship instruments, transportation instruments, traffic signal instruments, combustion control instruments, life support equipment, all types of safety devices, etc. Unintended Usage of Toshiba products listed in this document shall be made at the customer's own risk.

NOTICE

PLEASE INFORM TOSHIBA INTERNATIONAL CORPORATION OR AUTHORIZED REPRESENTATIVE IN CASE OF INCONSISTENCIES, OMISSIONS, OR QUESTIONS.

The instructions contained in this manual are not intended to cover all of the details or variations in equipment, nor to provide for every possible contingency concerning installation, operation, or maintenance. Should further information be required or if problems arise which are not covered sufficiently contact your Toshiba sales office.

The contents of this instruction manual shall not become a part of or modify any prior or existing agreement, commitment, or relationship. The sales contract contains the entire obligation of Toshiba International Corporation's UPS Division. The warranty contained in the contract between the parties is the sole warranty of Toshiba International Corporation's UPS Division and any statements contained herein DO NOT create new warranties or modify the existing warranty.

Any electrical or mechanical modifications to this equipment without prior written consent of Toshiba International Corporation will void all warranties and may void the UL/CUL listing. Unauthorized modifications can also result in personal injury, death, or destruction of the equipment.

QUALIFIED PERSONNEL ONLY

Qualified Personnel is one that has the skills and knowledge relating to the construction, installation, operation, and maintenance of the electrical equipment and has received safety training on the hazards involved (Refer to the latest edition of NFPA 70E for additional safety requirements).

UNINTERRUPTIBLE POWER SYSTEM (UPS)

Please complete the following information and retain for your records.

Unless otherwise specified, the warranty period for the UPS or UPS part is 12 months from the shipment date (see Toshiba International Corporation bill of lading).

Unless otherwise specified, the warranty period for a UPS battery is 36 months from the shipment date (see Toshiba International Corporation Bill of Lading for shipping date).

JOB NUMBER

MODEL NUMBER

SERIAL NUMBER

APPLICATION

SHIPMENT DATE

INSTALLATION DATE

INSPECTED BY

Purpose

This manual provides information on how to safely install and operate your Toshiba International Corporation power electronics product. This manual includes a section of general safety instructions that describes the warning labels and symbols that are used throughout the manual. Read the manual completely before installing, operating, or performing maintenance on this equipment.

This manual and the accompanying drawings should be considered a permanent part of the equipment and should be readily available for reference and review. Dimensions shown in the manual are in metric and/or the English customary equivalent.

Toshiba International Corporation reserves the right, without prior notice, to update information, make product changes, or discontinue any product or service identified in this publication.

Toshiba is a registered trademark of the Toshiba Corporation. All other product or trade references appearing in this manual are registered trademarks of their respective owners.

Toshiba International Corporation shall not be liable for direct, indirect, special, or consequential damages resulting from the use of the information contained within this manual.

This manual is copyrighted. No part of this manual may be photocopied or reproduced in any form without the prior written consent of Toshiba International Corporation.

© Copyright 2013 Toshiba International Corporation
All rights reserved.
Printed in the U.S.A.

Toshiba's Customer Support Center

Contact the Toshiba Customer Support Center for assistance with application information or for any problems that you may experience with your Uninterruptible Power System (UPS).

Toshiba Customer Support Center
8 a.m. to 5 p.m. (CST) - Monday through Friday
USA Toll Free (877) 867-8773
Tel (713) 466-0277
Fax (713) 896-5212

You may also contact Toshiba by writing to:

Toshiba International Corporation
13131 West Little York Road
Houston, Texas 77041-9990
Attn: UPS Product Manager

For further information on Toshiba's products and services, please visit our website at:

www.toshiba.com/ind

Table of Contents

| | | |
|-----------|--|-----------|
| 1 | Introduction..... | 1 |
| 2 | General Safety Instructions..... | 2 |
| 2.1 | Symbols | 2 |
| 2.2 | Signal Words..... | 3 |
| 2.3 | Qualified Personnel..... | 3 |
| 2.4 | Factory Authorized Personnel..... | 4 |
| 3 | Important Safety Instructions..... | 4 |
| 4 | Safety Precautions | 5 |
| 4.1 | Disclaimer | 5 |
| 4.2 | General Maintenance..... | 6 |
| 4.3 | Transporting/Unpacking..... | 6 |
| 4.4 | Inspection/Storage | 8 |
| 5 | Installation Precautions | 9 |
| 5.1 | Wiring/Connection..... | 13 |
| 6 | Warning Labels | 14 |
| 6.1 | Warning Label Locations..... | 15 |
| 7 | Weight and Dimensions | 18 |
| 8 | Transporting..... | 19 |
| 8.1 | Transporting By Crane | 20 |
| 8.2 | Transporting By Forklift..... | 21 |
| 9 | Storage/Operating Environment | 23 |
| 9.1 | Operating Precautions | 23 |
| 9.2 | Maintenance Precautions | 25 |
| 9.3 | Disposal | 26 |
| 10 | Installation..... | 27 |
| 10.1 | Unpacking | 28 |
| 10.2 | UPS Clearance | 28 |
| 10.3 | Anchor Bolts..... | 29 |
| 11 | UPS Wiring | 30 |
| 11.1 | 80/100/125 kVA Terminal Blocks and Power Cables..... | 32 |

| | | |
|-----------|--|-----------|
| 11.2 | 150, 225, 300, and 500 kVA Buss Strip Terminals and Power Cables | 34 |
| 11.3 | UPS Power Cable Conduit Landing Plates | 39 |
| 11.4 | External Breakers..... | 42 |
| 11.5 | Grounding Wire | 42 |
| 11.6 | Control Wires..... | 44 |
| 11.7 | Grounding Configuration | 45 |
| 12 | UPS Specifications..... | 49 |
| 12.1 | Specification Table | 49 |
| 12.2 | Typical Efficiency vs. Load | 52 |
| 13 | Operator Interface | 53 |
| 13.1 | Key-Switch and Buttons..... | 54 |
| 13.2 | LCD/LED Indicators | 55 |
| 13.3 | LCD Indicators | 56 |
| 13.4 | Normal Display..... | 57 |
| 13.5 | Fault Display | 59 |
| 13.6 | LCD Scroll..... | 60 |
| 14 | Operating the UPS..... | 61 |
| 14.1 | Operation Types..... | 62 |
| 14.2 | Pre-operational Check | 62 |
| 14.3 | Startup Procedures | 63 |
| 14.4 | Switch Power Supply (UPS to Bypass)..... | 65 |
| 14.5 | Stop..... | 66 |
| 14.6 | Complete Shutdown..... | 67 |
| 14.7 | Changing Between Float Charge and Equalize Charge | 68 |
| 14.8 | Changing to Float Charge from Protection Charge (If applicable) | 69 |
| 14.9 | Emergency Power Off (EPO)..... | 70 |
| 15 | Troubleshooting | 70 |
| 15.1 | Types of Errors..... | 70 |
| 15.2 | Faults and Warnings Data Screen | 71 |
| 15.3 | LCD Fault & Warning Displays..... | 72 |
| 15.4 | Fault Messages..... | 73 |
| 15.5 | LCD Scroll (w/ faults or warnings)..... | 75 |
| 15.6 | Restoring UPS Operation | 76 |

| | | |
|-------------------|--|------------|
| 16 | Periodic Maintenance/Parts Replacement | 77 |
| 16.1 | Scheduled Maintenance | 77 |
| 16.2 | Parts Replacement | 77 |
| Appendix A | - Installation Planning Guides | 79 |
| | 80kVA IPG..... | 79 |
| | 100kVA IPG..... | 82 |
| | 125kVA IPG..... | 85 |
| | 150kVA IPG..... | 88 |
| | 225kVA IPG..... | 91 |
| | 300kVA IPG..... | 94 |
| | 500kVA IPG..... | 97 |
| Appendix B | - Outline Drawings..... | 101 |
| Appendix C | - 500kVA Input- and Output- Cabinet Joining Instructions..... | 105 |

1 Introduction

This manual provides information on how to safely operate your G8000 Series Uninterruptible Power System (UPS). This manual includes a section of general safety instructions that describes the warning labels and symbols that are used throughout the manual. Read the manual completely before installing, operating, or performing maintenance on this equipment.

Qualified personnel should read this manual carefully before transporting, installing and wiring the UPS. In addition have a thorough understanding of the information provided in the chapters titled:

- General Safety Instructions
- Important Safety Instructions
- Safety Precautions
- Installation Precautions

Please read the G8000 Series Operation Manual for important instructions on operating the UPS. This manual and the accompanying drawings should be considered a permanent part of the equipment and should be readily available for reference and review. Dimensions shown in the manual are in metric and/or the English customary equivalent.

Keep the Installation Manual and the Operation Manual near the UPS for necessary reference.

SAVE THESE INSTRUCTIONS

2 General Safety Instructions

DO NOT attempt to transport, install, operate, maintain or dispose of this equipment until you have read and understood all of the product safety information provided in this manual.

2.1 Symbols

The symbols listed below are used throughout this manual. When symbols are used in this manual they will include important safety information that must be carefully followed.



Safety Alert Symbol indicates that a potential personal injury hazard exists.



Prohibited Symbol indicates **DO NOT** take action.



Mandatory Symbol indicates that the following instruction is required.



Ground Symbol indicates the location of the equipment grounding conductor.



Electrical - Voltage & Shock Hazard Symbol indicates parts inside may cause electric shock.



Explosion Hazard Symbol indicates parts may explode.

2.2 Signal Words

The signal words listed below are used throughout this manual. When the words DANGER, WARNING, CAUTION and ATTENTION are used in this manual they will include important safety information that must be carefully followed.



The word **DANGER** in capital letters preceded by the safety alert symbol indicates that an **imminently hazardous** situation exists, and if not avoided **will result in loss of life or serious injury to personnel**.



The word **WARNING** in capital letters preceded by the safety alert symbol indicates that a **potentially hazardous** situation exists, and if not avoided **may result in loss of life or serious injury to personnel**.



The word **CAUTION** in capital letters preceded by the safety alert symbol indicates that a **potentially hazardous** situation exists, and if not avoided **may result in minor or moderate injury**.



The word **NOTICE** in capital letters without the safety alert symbol indicates a **potentially hazardous** situation exists, and if not avoided **may result in equipment and property damage**.

2.3 Qualified Personnel

Installation, operation, and maintenance shall be performed by Qualified Personnel Only. A Qualified Person is one that has the skills and knowledge relating to the construction, installation, operation, and maintenance of the electrical equipment and has received safety training on the hazards involved (Refer to the latest edition of NFPA 70E for additional safety requirements).

Qualified Personnel shall:

- Have read the entire operation manual.
- Be familiar with the construction and function of the UPS, the equipment being driven, and the hazards involved.
- Be trained and authorized to safely energize, de-energize, ground, lockout/tagout circuits and equipment, and clear faults in accordance with established safety practices.
- Be trained in the proper care and use of protective equipment such as safety shoes, rubber gloves, hard hats, safety glasses, face shields, flash clothing, etc., in accordance with established safety practices.

- Be trained in rendering first aid.

For further information on workplace safety visit www.osha.gov.

2.4 Factory Authorized Personnel

Factory authorized personnel have been factory trained and certified to install, service, and repair the UPS. Contact the Toshiba Customer Support Center for assistance in locating the factory authorized personnel nearest you.

3 Important Safety Instructions

The following contains important instructions that should be followed during the installation, operation, and maintenance of the G8000 Series UPS.

Please refer to the battery manufacturer's instructions for details on operating, maintaining and/or replacing the batteries for each system. Keep unauthorized personnel from batteries. Only a certified service representative with battery experience should perform service on batteries.

CAUTION

Misuse of this equipment could result in personal injury and/or equipment damage. In no event will Toshiba Corporation be responsible or liable for either indirect or consequential damage or injury that may come from the use of this equipment.

The UPS system input and output is NOT equipped with an over-current protection device, or an output disconnection at the AC output. The user should provide circuit breakers between the UPS AC input (or Bypass input) and the power sources and between the UPS output and the critical load input. The minimum device ratings are listed in Table 3.1.

TABLE 3.1 UPS MINIMUM DEVICE RATINGS

| CAPACITY | RATED OUTPUT | INPUT BREAKER RATING | OUTPUT BREAKER RATING |
|----------|--------------|----------------------|-----------------------|
| 80 kVA | 480 V/277 V | 480 V – 150 A | 480 V – 125 A |
| 100 kVA | 480 V/277 V | 480 V – 200 A | 480 V – 150 A |
| 125 kVA | 480 V/277 V | 480 V – 200 A | 480 V – 200 A |
| 150 kVA | 480 V/277 V | 480 V – 300 A | 480 V – 250 A |
| 225 kVA | 480 V/277 V | 480 V – 400 A | 480 V – 350 A |
| 300 kVA | 480 V/277 V | 480 V – 600 A | 480 V – 500 A |
| 500 kVA | 480 V/277 V | 480 V – 800 A | 480 V – 800 A |

80/100/150/225/300 kVA Temperature restrictions: The maximum operating ambient temperature is 86 °F (30 °C) at 1.0 PF, and 104 °F (40 °C) at 0.8 PF. If the UPS is exposed to the same ambient temperature as the battery system, the maximum operating ambient temperature is 86 °F (30 °C) at 1.0 PF, 90 °F (32 °C) at 0.8 PF. Table 3.2 lists the nominal battery voltage.

TABLE 3.2 UPS NOMINAL BATTERY VOLTAGE

| CAPACITY | NOMINAL VOLTAGE | FLOAT VOLTAGE |
|----------|-----------------|---------------|
| 80 kVA | 360 Vdc | 405 V |
| 100 kVA | 360 Vdc | 405 V |
| 125 kVA | 360 Vdc | 405 V |
| 150 kVA | 360 Vdc | 405 V |
| 225 kVA | 360 Vdc | 405 V |
| 300 kVA | 360 Vdc | 405 V |
| 500 kVA | 480 Vdc | 540 V |

4 Safety Precautions

The Toshiba products listed in this document are intended for usage in general electronics applications (computer, personal equipment, office equipment, measuring equipment, industrial robotics, domestic appliances, etc.). These Toshiba products are neither intended nor warranted for use in equipment that, if a malfunction or failure occurs, may result in loss of human life or bodily injury (collectively referred to as “Unintended Usage”). Unintended Usage includes atomic energy control instruments, airplane or spaceship instruments, transportation instruments, traffic signal instruments, combustion control instruments, medical operating room or life support equipment, all types of safety devices, etc. Unintended Usage of Toshiba products listed in this document shall be made at the customer’s own risk.





The application of the UPS without special consideration for equipment that supports human safety and/or maintain public services may cause serious accidents.

4.1 Disclaimer



IN NO EVENT WILL TOSHIBA CORPORATION BE RESPONSIBLE OR LIABLE FOR EITHER INDIRECT OR CONSEQUENTIAL DAMAGE OR INJURY THAT MAY COME FROM THE MISUSE OF THIS EQUIPMENT. ANY MODIFICATIONS WITHOUT AUTHORIZATION BY TOSHIBA COULD RESULT IN PERSONAL INJURIES, DEATH OR DESTRUCTION OF THE UPS.

TOSHIBA RESERVES THE RIGHT TO MAKE CHANGES WITHOUT FURTHER NOTICE TO ANY PRODUCTS HEREIN TO IMPROVE RELIABILITY, FUNCTION OR DESIGN. TOSHIBA DOES NOT ASSUME ANY LIABILITY ARISING OUT OF THE APPLICATION OR USE OF ANY PRODUCT OR UPS DESCRIBED HEREIN; NEITHER DOES IT CONVEY ANY LICENSE UNDER ITS PATENT RIGHTS, NOR THE RIGHTS OF OTHERS.

4.2 General Maintenance

|  WARNING | |
|--|---|
|  | <p>DO NOT remove the rear/side panels, or any sheet metla not designed to be removed.</p> <p>Removing rear/side panels may result in electric shock, burns, personal injuries or UPS failure.</p> |
|  | <p>Keep the area around the UPS clean.</p> <p>Use a vacuum cleaner to clean the UPS.</p> |
|  | <p>Only factory authorized personnel sould perform internal general maintenance on the UPS.</p> |
|  | <p>Contact the authorized Toshiba Customer Support Center or an authorized Toshiba representative for informaton on proper disposal of UPS components.</p> <p>It is illegal to dispose of certain components without conforming to environmental regulations for indusrial/commercial waste.</p> |

4.3 Transporting/Unpacking

|  WARNING | |
|--|--|
| <p>When transporting the UPS by crane, follow the SPECIFIED WORK PROCEDURE. The suspension wire angle should be less than 60°.</p> <p>The UPS falling or overturning may cause crushing, trapping or other personal injuries.</p> <p><i>See Installation Manual: Chapter 8 - Transporting</i></p> | |
|  | <p>DO NOT tilt the UPS more than 10° from upright position.</p> <p>Tilting the UPS more than 10° may cause crushing, trapping or other personal injuries.</p> |





|  CAUTION | |
|--|--|
|  | <p>DO NOT transport, move, store, or place the UPS on its side. Forces due to heavy components inside may damage the UPS.</p> |
|  | <p>Avoid vibration or shock exceeding 0.5G. Failing to observe this precaution may cause damage to the UPS.</p> |
|  | <p>DO NOT allow the UPS to suffer shock or impact when unpacking. Tools used to remove packaging materials may cause damage to the UPS.</p> |
|  | <p>DO NOT push or pull on the sides of the packaging or the UPS to move it. Always use a crane, forklift, or pallet jack for transporting and positioning the UPS. Pushing/pulling on the sides of the unit to move it may result in damage to the UPS. See Figure 4.1 Exterior Handling label.</p> |

Fig. 4.1 Exterior Handling label



4.4 Inspection/Storage

Inspection

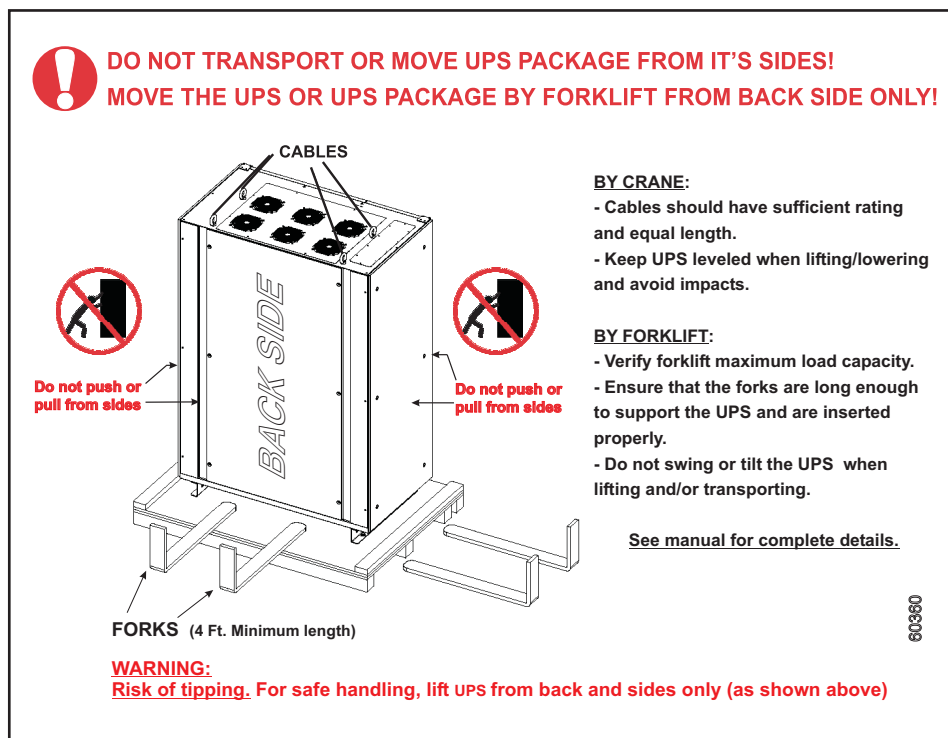
Upon receipt of the UPS, an inspection for shipping damage should be performed. Use caution when removing the unit from the pallet. Refer to labels or documentation attached to packing material.

Unpacking

Check the unit for loose, broken, bent or otherwise damaged parts. If damage has occurred during shipping, keep all original crating and packing materials for return to the shipping agent.

NOTE: The factory warranty does not apply to damage incurred during shipping!

Ensure that the rated capacity and the model number specified on the nameplate conform to the order specifications.

Storage

During periods of non-use, the following guidelines are recommended for storage.

Storage Preparation

- 1) Power up the UPS and allow it to operate with no load for 24 hours to fully charge the batteries.
- 2) Stop the unit.
- 3) Place the Main Circuit Breaker switch in the "OFF" position.







Storage Conditions



- For best results, store the UPS in the original shipping container and place on a wood or metal pallet
- Storage temperature range: -4 to 104 °F (-20 to 40 °C)
- The optimum storage temperature is 70 °F (21 °C). A higher ambient temperature will require recharging more frequently during storage

Avoid the following storage locations:

- Locations that are subject to extreme temperature changes or high humidity
- Locations that are subject to high levels of dust or metal particles
- Locations that are subject to excessive vibration
- Inclined floor surfaces

5 Installation Precautions

|  CAUTION | |
|--|---|
|  | <p>Install the UPS in a controlled environment.</p> <p>Improper storage and installation environment may deteriorate insulation, shorten component life and cause malfunctions.</p> <p><i>See Table 5.1 - UPS Installation Environment Standards</i></p> |
|  | <p>DO NOT tilt the UPS more than 10° from upright position.</p> <p>Tilting the UPS more than 10° may cause crushing, trapping or other personal injuries and cause physical damage to internal components.</p> |
|  WARNING | |
|  | <p>Keep the SPECIFIED CLEARANCE around the UPS.</p> <p>Inadequate space around the UPS makes it difficult to perform maintenance/inspections, will lead to insufficient ventilation, and/or cause malfunctions.</p> |
|  | <p>Install anchor bolts to secure the UPS to the installation floor.</p> <p>The UPS may fall during an earthquake if the anchor bolts are not installed and secured.</p> |
|  | <p>Only factory authorized personnel should relocate, modify, or replace parts in the UPS after initial installation.</p> <p>Electrical shock, injury or UPS failure may occur if non-authorized technicians attempt to modify or relocate the UPS.</p> <p>Please contact Toshiba Customer Support Center if you plan to move or make modifications to the UPS</p> |

| | |
|---|--|
|  | <p>DO NOT block air vents.</p> <p>Blocking the vents will increase the internal temperatures and may result in UPS failure or fire.</p> |
|  | <p>DO NOT install the UPS where water may fall on it.</p> <p>Water may cause electrical shock, personal injury or UPS failure.</p> |
|  | <p>DO NOT use floor wax that contains silicon in the UPS storage area and/or nearby rooms.</p> <p>Floor wax that contains silicon may cause static electricity.</p> |



| | |
|---|---|
|  WARNING | |
|  | <p>The UPS should be installed per local and/or national electric codes by qualified personnel.</p> <p>Faults or improper operation may occur if the UPS is not installed properly.</p> |
|  | <p>When an external maintenance bypass is installed for the UPS, before switching to external bypass, ensure that the UPS unit is switched to AC Bypass mode and the UPS control panel display verifies the unit is Bypass mode.</p> <p>Switching to the external bypass while the unit is in UPS mode may damage the UPS.</p> |

TABLE 5.1 - UPS INSTALLATION ENVIRONMENT STANDARDS

| Item | Environment standard | |
|--------------------------------|--|---|
| Installation Location | Indoors | |
| Ambient Temperature | Minimum operating temperature: 32 °F (0 °C). | |
| | Maximum operating temperature: 86 °F (30 °C) at 1.0 PF (UPS with/without battery system). | |
| | Maximum operating temperature: 90 °F (32 °C) at 0.8 PF (UPS with battery system). | |
| | Maximum operating temperature: 104 °F (40 °C) at 0.8 PF (UPS only). | |
| | Average 24-hour operating temperature: 86 °F (30 °C) at 1.0 PF and 41 – 95 °F (5 – 35 °C) at 0.8 PF. | |
| Relative Humidity | The relative humidity must be between 30 and 90% noncondensing due to temperature changes. | |
| Altitude | These specifications are for altitudes up to 3240 ft. (1000 m) above sea level. Consult with the factory to determine the derating factor for installations above 3240 ft. (1000 m). | |
| Vibration and Mechanical Shock | Installation environment must not have vibration frequencies 10 Hz – 20 Hz. | |
| | The acceleration due to vibrations less than 10 Hz must not exceed 0.5 G. | |
| | The acceleration due to vibrations 20 Hz – 50 Hz must not exceed 0.5 G. | |
| | The total amplitude due to vibrations 50 Hz – 100 Hz must not exceed 0.1 mm. | |
| Dust | Dust must not exceed normal atmospheric levels and must not include conductive particles, silicone or oils. | |
| Flammable Gas | No flammable and/or explosive gas. | |
| | Hydrogen sulfide (H ₂ S) | Less than or equal to 0.0001 PPM |
| | Sulfurous acid gas (SO ₂) | Less than or equal to 0.05 PPM |
| | Chlorine gas (Cl ₂) | Less than or equal to 0.002 PPM |
| | Ammonia gas (NH ₃) | Less than or equal to 0.1 PPM |
| | Nitrous acid gas (NO ₂) | Less than or equal to 0.02 PPM |
| | Nitrous oxides (NOx) | Less than or equal to 0.02 PPM |
| | Ozone (O ₃) | Less than or equal to 0.002 PPM |
| | Hydrochloric acid mist (HCl) | Less than or equal to 0.1 mg/m ³ |

Installation Precautions

- 1) Install the unit in a stable, level and upright position that is free of excessive vibration.
- 2) Install the unit where the ambient temperature is within the specified range.
- 3) DO NOT install the UPS in areas that are subject to high humidity.
- 4) DO NOT install the UPS in areas that allow exposure to direct sunlight.
- 5) DO NOT install the UPS in areas that allow exposure to high levels of airborne dust, metal particles, or flammable gases.
- 6) DO NOT install the UPS in areas near sources of electrical noise. Ensuring a proper earth ground will reduce the effects of electrical noise and will reduce the potential for electrical shock.

- 7) The UPS generates and can radiate radio-frequency energy during operation. Although RFI noise filters are installed inside of the unit, there is no guarantee that the UPS will not influence some sensitive devices that are operating near by. If such interference is experienced, the UPS should be installed further away from the affected equipment and/or powered from a different source than that of the installed equipment.
- 8) The user should provide over-current protection for hardwired UPS systems between the UPS output and the load input.
- 9) After ensuring that all power sources are turned “OFF” and isolated in accordance with established lockout/tagout procedures, connect the power source wiring of the correct voltage to the input terminals of the UPS.

NOTE: Ensure the input phasing is connected in clockwise rotation (CW). UPS internal circuitry is designed to disable further UPS operation if the input phasing is installed in counter-clockwise rotation (CCW).





- 10) Connect the output terminals of the UPS to the load (refer to NEC Article 300 - Wiring Methods and Article 310 - Conductors For General Wiring). Size the branch circuit conductors in accordance with NEC Table 310.16 as published 9/2007.

| | |
|--|---|
|  WARNING | |
|  | METAL CONDUIT IS NOT AN ACCEPTABLE GROUND. |

Conductor Routing and Grounding

- 1) Use separate metal conduits for routing the input power, output power, and control circuits.
- 2) Follow the wire size and tightening torque specifications.
- 3) Always ground the unit to reduce the potential for electrical shock and to help reduce electrical noise.
- 4) A separate ground cable should be run inside the conduit with the input power, output power, and control circuits.

5.1 Wiring/Connection

|  WARNING | |
|--|--|
|  | <p>Perform wiring and connections with correct polarity.</p> <p>Be careful when connecting the UPS to the battery system. A wrong connection may cause damage to the UPS, battery, or charger.</p> |
|  | <p>Connect ONLY one (1) ground wire to the earth ground terminal.</p> <p>A missing ground wire may cause an electrical shock hazard. Connecting to more than one ground may cause a ground loop.</p> <p><i>See Chapter 8 - UPS Wiring</i></p> |
|  | <p>DO NOT force, bend, or pull wires.</p> <p>DO NOT damage wire insulation.</p> <p>DO NOT place heavy objects on top of UPS.</p> |
|  | <p>Observe the above precautions when making wire connections or handling the wires. Failing to observe these precautions may damage the insulation of the wires or may cause a fire or an electric shock hazard.</p> |

| NOTICE | |
|---|--|
| <p>Follow the torque criteria for tightening screws.</p> <p>Loose connections may cause fire due to heating.</p> <p><i>See Chapter 11 - UPS Wiring</i></p> | |

6 Warning Labels

Below are representative warning labels and their location on the UPS. Exterior Handling labels shown in section 4.3, Transporting/Unpacking, are in the manual packet, and attached to the UPS shipping covering and shipping pallet.

NOTICE

Make sure all the warning labels are installed in the appropriate locations.

If a label is missing or illegible, contact Toshiba Customer Support Center or an authorized representative.

(A) 48082

DANGER

AC VOLTAGE

This UPS receives power from more than one source. Disconnect all AC sources before performing any service or testing inside this unit

48082

(B) 40308

DANGER

HAZARDOUS VOLTAGES

Hazardous voltages are used in the operation of this equipment and could cause severe personal injury or loss of life. The following precautions should be observed to reduce the risk of injury or death.

Only qualified technicians familiar with this equipment and the information supplied with it should be permitted to install and operate this equipment.

Installation of electrical equipment must be done in accordance with National Electrical Code and any other state or local codes. Proper grounding and conductor sizing must be installed for safe operation.

During operation, keep all covers in place and cabinet doors shut.

When performing visual inspections and maintenance, if possible, be sure the UPS is turned off and the incoming AC feed is turned off and locked out.

The UPS and Battery Cabinet will have hazardous voltages present even after the AC feed is turned off.

If it is necessary to make measurements with the power on, do not touch any electrical connection points. Remove all jewelry from wrists and fingers. Make sure test equipment is in good, safe operating condition.

While servicing, stand on some type of insulation, and be sure not to be grounded.

Follow the safety instructions given in the equipment manual carefully and observe all danger, warning and caution notices.

40308

(C) 56875 FOR 80, 100, 150, 225 KVA

USE COPPER CONDUCTORS ONLY!
REFER TO INSTRUCTION MANUAL FOR WIRE SIZE AND TIGHTENING TORQUE

| | | | | | | | | | | | | |
|----------|---|---|--------------|---|---|-----------|---|---|---------|----|----|----|
| 1 | 2 | 3 | 4 | 5 | 6 | 7 | 8 | 9 | 10 | 11 | 12 | 13 |
| U | V | W | U | V | W | N | U | V | W | N | - | + |
| 480 V | | | 480 V | | | 480 V | | | 400 V | | | |
| AC INPUT | | | BYPASS INPUT | | | AC OUTPUT | | | BATTERY | | | |

(C) 58708 FOR 300KVA

USE COPPER CONDUCTORS ONLY!
REFER TO INSTRUCTION MANUAL FOR WIRE SIZE AND TIGHTENING TORQUE

| | | | | | | | | | | | |
|----------|---|---|---------|---|--------------|---|---|-----------|----|----|----|
| 1 | 2 | 3 | 4 | 5 | 6 | 7 | 8 | 9 | 10 | 11 | 12 |
| U | V | W | - | + | U | V | W | N | U | V | W |
| 480 V | | | 400 V | | 480 V | | | 480 V | | | |
| AC INPUT | | | BATTERY | | BYPASS INPUT | | | AC OUTPUT | | | |

(D) 40830

WARNING

CRITICAL FUSE SIZING

Incorrect fuse replacement size may result in fire or inadequate equipment protection.

Replace only with same type and rating of fuse.

PN 40830

(E) 39561

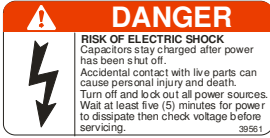

(F) 58705 SERIAL LABEL

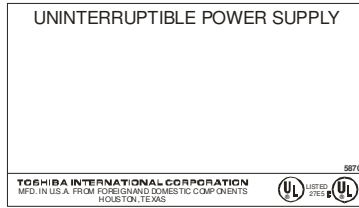

(G) 57055



(I) 40831

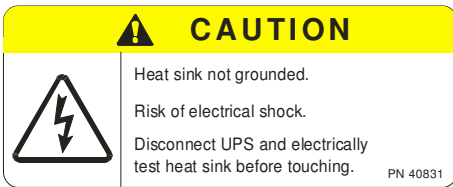

(J) 57053

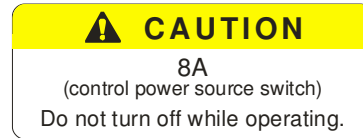

6.1 Warning Label Locations

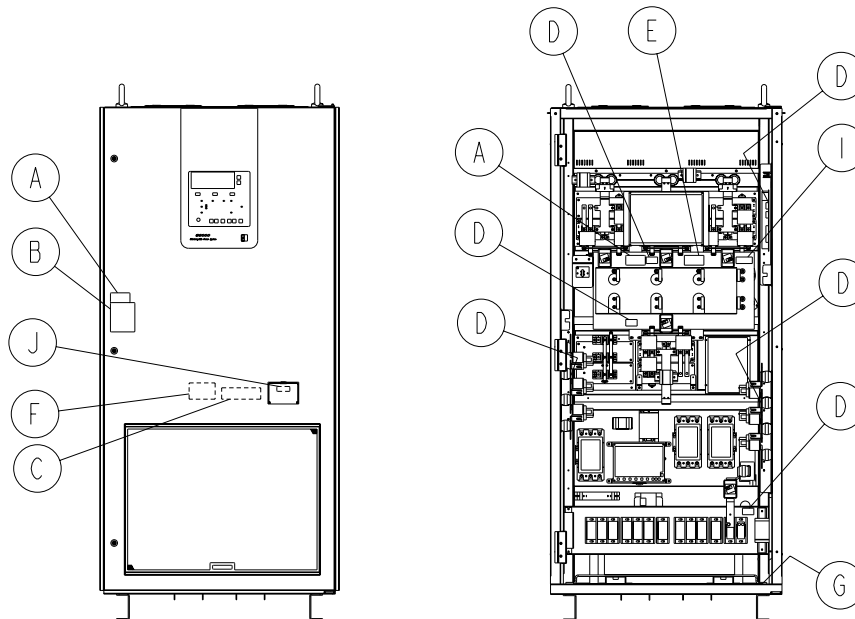

FIGURE 6.2 – 80/100/125 KVA UPS WARNING LABELS

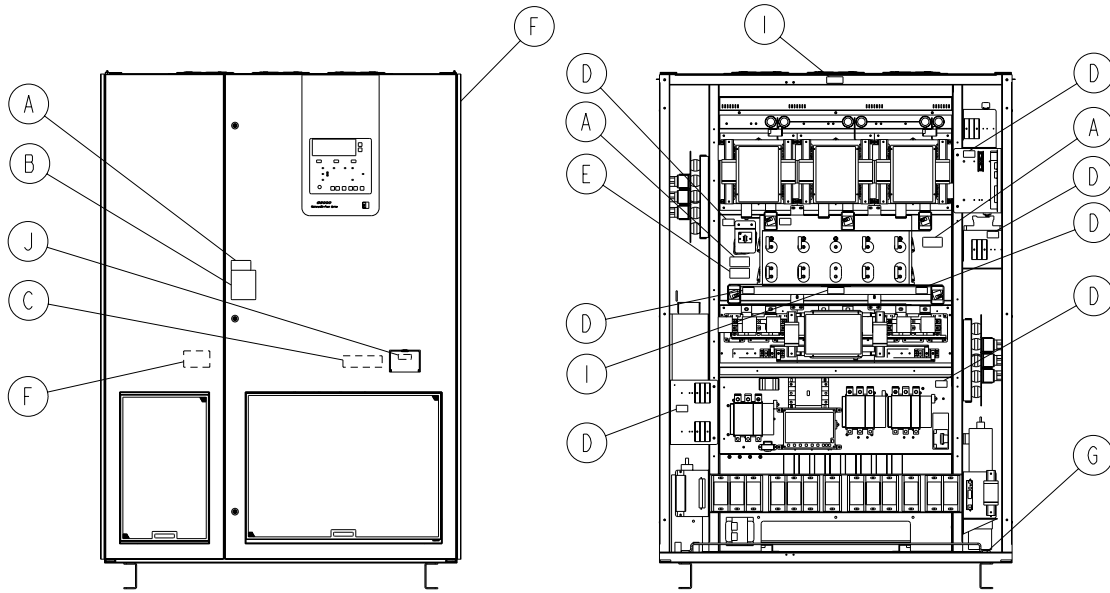

FIGURE 6.3 – 150/225 KVA UPS WARNING LABELS

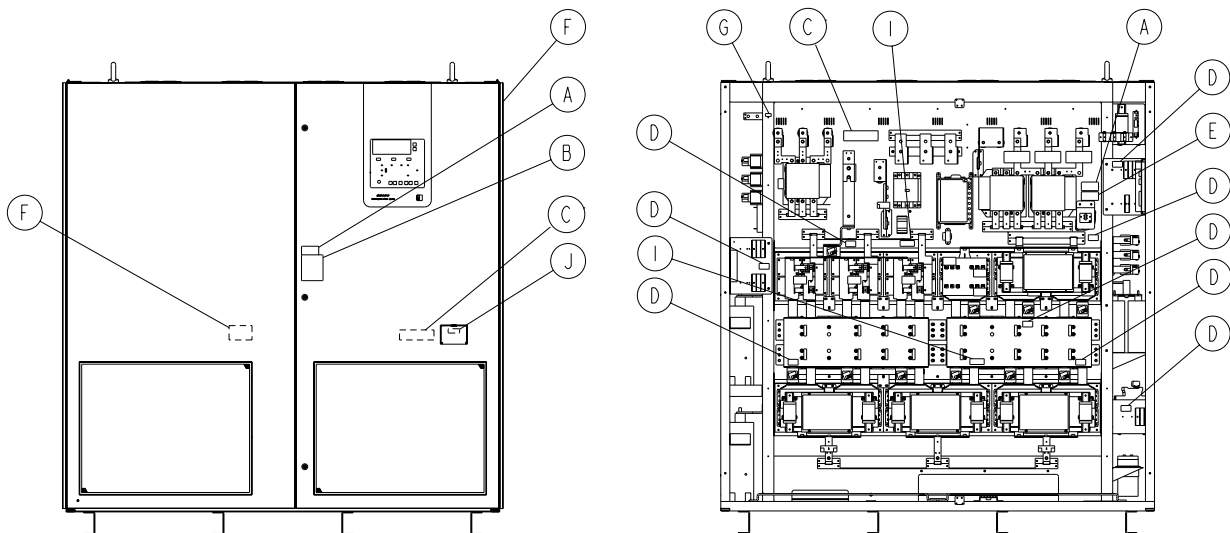

FIGURE 6.4 - 300 KVA UPS WARNING LABELS

**FINAL LAYOUT NOT AVAILABLE AT THIS TIME:
CONTACT THE FACTORY FOR ADDITIONAL
INFORMATION**

FIGURE 6.3 – 500 KVA UPS WARNING LABELS

7 Weight and Dimensions









Table 7.1 lists the unit and shipping weights for G8000 UPS models. See Appendix B for detailed outline and dimensions of all models.

TABLE 7.1 G8000 UPS UNIT AND SHIPPING WEIGHTS

| Model | Unit | Shipping |
|--------------------------|---------------------------------|----------------------------------|
| 80 kVA | 1390 lb. (630 kg) | 1440 lb. (652 kg) |
| 100 kVA | 1740 lb. (789 kg) | 1790 lb. (812 kg) |
| 125 kVA | 1740 lb. (789 kg) | 1790 lb. (812 kg) |
| 150 kVA | 2467 lb. (1119 kg) | 2556 lb. (1159 kg) |
| 225 kVA | 2980 lb. (1352 kg) | 3069 lb. (1392 kg) |
| 300 kVA | 4575 lb. (2075 kg) | 4725 lb. (2143 kg) |
| 500 kVA (Input Cabinet) | 1570 lb. (712 kg) ¹ | ~1620 lb. (735 kg) ¹ |
| 500 kVA (Output Cabinet) | 4950 lb. (2245 kg) ¹ | ~5100 lb. (2313 kg) ¹ |

1 - Weights are approximate.

8 Transporting

| | |
|--|--|
|  WARNING | |
| <p>When transporting the UPS by crane, follow the SPECIFIED WORK PROCEDURE. The suspension wire angle should be less than 60°.</p> <p>The UPS falling or overturning may cause crushing, trapping or other personal injuries.</p> | |
|  | <p>DO NOT tilt the UPS more than 10° from upright position.</p> <p>Tilting the UPS more than 10° may cause crushing, trapping or other personal injuries.</p> |
|  CAUTION | |
|  | <p>DO NOT transport, move, store, or place the UPS on its side.</p> <p>Excessive force applied from heavy components inside may damage the UPS.</p> |
|  | <p>Avoid vibration or shock exceeding 0.5G.</p> <p>Failing to observe this precaution may cause damage to the UPS.</p> |
|  | <p>DO NOT allow the UPS to suffer shock or impact when unpacking.</p> <p>Tools used to remove packaging materials may cause damage to the UPS.</p> |
|  | <p>DO NOT install the UPS where water may fall on it.</p> <p>Water may cause electrical shock, personal injury or UPS failure.</p> |
|  | <p>DO NOT push or pull on the sides of the packaging, or the UPS to move it. Always use a crane, forklift, or pallet jack for transporting and positioning the UPS.</p> <p>Pushing/pulling on the sides of the unit to move it may result in damage to the UPS. (See Figure 4.1 Exterior Handling label.)</p> |

The UPS may be packed in a crate for extra protection during transportation. Avoid impact or vibration against the UPS during transportation. DO NOT expose the UPS directly to water.

8.1 Transporting By Crane

Cables should have sufficient ratings and be of the same length. Make sure the suspension cables are hooked at eyebolts. See Figure 8.1. Keep the angle less than 60° between cables.

Refer to Chapter 7 - Weight and Dimension for UPS cabinet weight.

Keep UPS leveled when lifting. DO NOT swing or tilt the UPS. Minimize the impact when lowering the UPS to the floor. Figure 8.2 and 8.3 indicate unacceptable lifting.

Figure 8.4 and 8.5 show examples of acceptable and unacceptable operations.

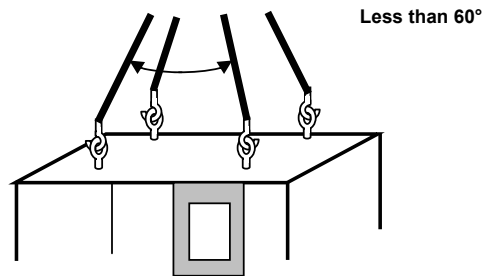

FIGURE 8.1 - CABLES AND EYEBOLTS TO LIFT THE UPS

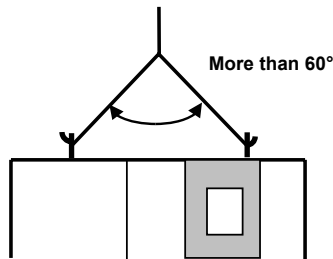

FIGURE 8.2 - ANGLE MORE THAN 60°

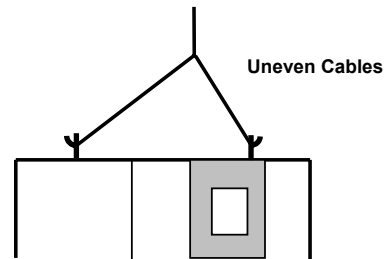

FIGURE 8.3 - UNEVEN CABLES

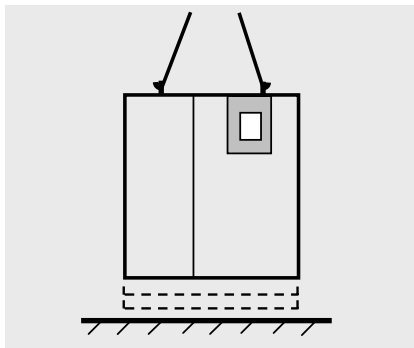

FIGURE 8.4 - ACCEPTABLE OPERATION

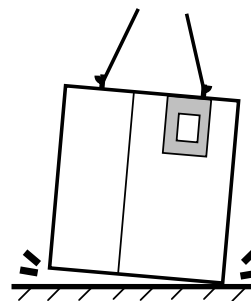

FIGURE 8.5 - UNACCEPTABLE OPERATION

8.2 Transporting By Forklift

Refer to Chapter 7 - Weight and Dimensions.

Verify forklift maximum load capacity and ensure that the forks are long enough to properly support the UPS. Insert the forks into the space shown in Figure 8.6. Spaces for the forks are provided underneath the UPS.

DO NOT swing or tilt UPS when lifting and/or transporting. Minimize the impact when lowering the UPS to the floor.

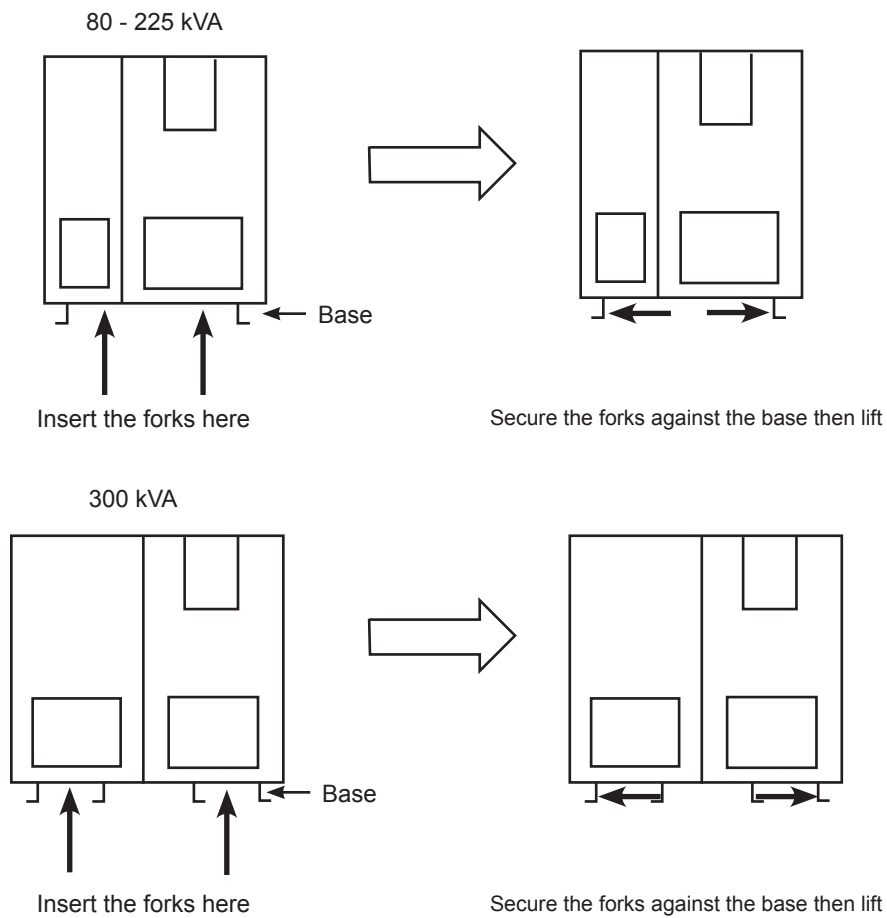

FIGURE 8.6 -TRANSPORTING 80-300 KVA UPS BY FORKLIFT

500 kVA
(Ships in two parts, Input
and Output Cabinets)

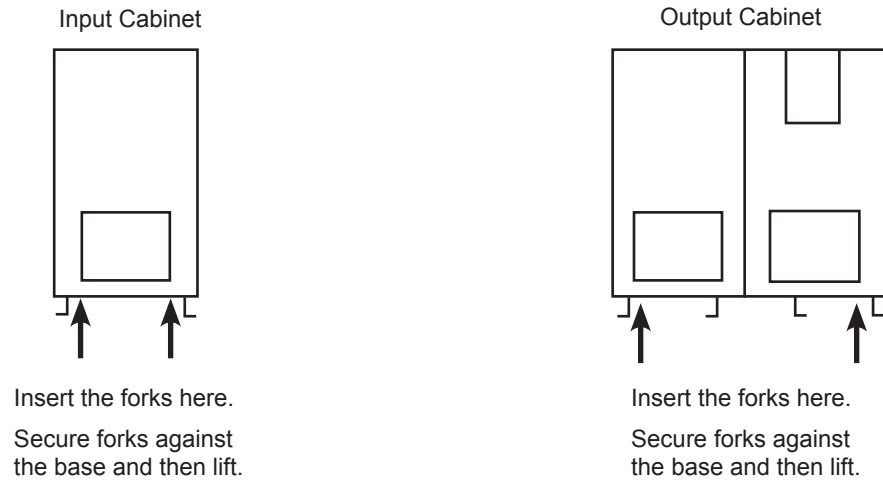

FIGURE 8.7 -TRANSPORTING 500 KVA UPS BY FORKLIFT
(See Appendix C for cabinet mating instructions)

9 Storage/Operating Environment

Observe the following when storing the UPS.

- Store UPS indoors.
- Maximum storage time for the UPS between powered operation cycles is three years. If the UPS has been stored for a period exceeding 36 months, contact your factory authorized representative of guidance in starting the unit.
- Temperature fluctuations should be minimized.
- The optimal storage temperature range is 68 – 77 °F (20 – 25° C).
- A maximum temperature range of 32 – 104 °F (0 – 40 °C) should be observed.
- The optimal relative humidity at the storage location should be between 50 – 60%.
- Humidity must not exceed 90%.
- Avoid locations where UPS may be exposed to corrosive gas.
- Avoid locations with dirt and/or dust.

TABLE 9.1 - UPS STORAGE/OPERATING ENVIRONMENT STANDARDS

| Item | Environment standard | |
|---------------------|---|---|
| Storage Location | Indoors | |
| Ambient Temperature | Minimum storage temperature: 32 °F (0 °C) | |
| | Maximum storage temperature: 104 °F (40 °C) | |
| Relative Humidity | The relative humidity must be between 30 and 90% and without condensation due to temperature changes. | |
| Altitude | This equipment is rated for installations up to 3240 ft. (1000m) above sea level. Consult with the factory to determine the derating factor for installations above 3240 ft. (1000m). | |
| Dust | Dust must not exceed normal atmospheric levels and must not include conductive particles, silicone or oils. | |
| Flammable Gas | No flammable and/or explosive gas. | |
| | Hydrogen sulfide (H ₂ S) | Less than or equal to 0.0001 PPM |
| | Sulfurous acid gas (SO ₂) | Less than or equal to 0.05 PPM |
| | Chlorine gas (Cl ₂) | Less than or equal to 0.002 PPM |
| | Ammonia gas (NH ₃) | Less than or equal to 0.1 PPM |
| | Nitrous acid gas (NO ₂) | Less than or equal to 0.02 PPM |
| | Nitrous oxides (NOx) | Less than or equal to 0.02 PPM |
| | Ozone (O ₃) | Less than or equal to 0.002 PPM |
| | Hydrochloric acid mist (HCl) | Less than or equal to 0.1 mg/m ³ |



9.1 Operating Precautions



Initial startup/comisioning of the UPS should be performed by factory authorized personnel.

- 1) The UPS should not be powered up until the entire operation manual has been read.
- 2) The voltage of the input power source must be within the rated input voltage range. The

input frequency range must be within the rated input frequency range.

- 3) The UPS should not be used with a load that has a rated input that is greater than the rated output of the UPS.
- 4) If using the UPS to provide power to motors that require high starting current or with motors that require a long starting time, call Toshiba support for guidance in over sizing the UPS for lock rotor current.
- 5) DO NOT insert metal objects or combustible materials in the ventilation slots of the UPS.
- 6) DO NOT place, hang, or paste any objects on the exterior surfaces of the UPS.
- 7) The capacitors in the UPS maintain a residual charge for a while after turning the UPS off. The required discharge time for each UPS typeform is provided via a cabinet label and a **CHARGE LED**. Wait for at least the minimum time indicated on the label and ensure that the **CHARGE LED** has gone out before opening the door of the UPS once the UPS power has been turned off.
- 8) DO NOT attempt to disassemble, modify, or repair the UPS. Call your Toshiba sales representative for repair information.
- 9) Turn the power on only after installing **ALL** of the covers.
- 10) DO NOT remove any covers of the UPS when power is on.
- 11) If the UPS should emit smoke or an unusual odor or sound, turn the power off immediately.
- 12) Warning signs should be placed on or near the load as a notification that the load is being powered by the UPS.
- 13) Additional warnings and notifications shall be posted at the equipment installation location as deemed required by **Qualified Personnel**.

|  WARNING | |
|--|---|
|  | <p>While operating in the inverter mode, placing the input breaker in the “OFF” position will switch the UPS to the battery backup mode.</p> <p>The output of the UPS will continue uninterrupted to the load. The unit must be in the bypass mode at the time that the breaker is placed in the “OFF” position for the UPS to shutdown power to the load.</p> |

|  CAUTION | |
|--|---|
|  | <p>After an Emergency Power Off (EPO), DO NOT reset the breaker until the UPS internal circuits have been fully discharged.</p> <p>The UPS could be damaged if the unit is not fully discharged before the breaker is reset.</p> |

9.2 Maintenance Precautions

All internal maintenance should be performed by factory authorized personnel.

- 1) Turn off, lockout, and tagout ALL power sources before connecting the power wiring to the equipment or when performing maintenance.
- 2) Hardwire type UPS units are not equipped with an over-current protection device, nor do they have an output disconnect for the AC output. A user-installed circuit breaker should be provided between the UPS output and the load input.
- 3) The maximum ambient operating temperature is 86 °F (30 °C) at 1.0 PF, and 104 °F (40 °C) at 0.8 PF.
- 4) Only factory authorized personnel should service the UPS. Contact Toshiba for the nearest authorized service center.
- 5) Battery servicing should be performed by factory authorized personnel only. Contact your nearest factory authorized service center for battery replacement.



Qualified Personnel ONLY!





Qualified Personnel have the skills and knowledge relating to the construction, installation, operation, and maintenance of the electrical equipment and has received safety training on the hazards involved (Refer to the latest edition of NFPA 70E for additional safety requirements).

Qualified Personnel shall:

- 1) Have read the entire operation manual.
- 2) Be trained and authorized to safely energize, de-energize, ground, lockout and tag circuits and equipment, and clear faults in accordance with established safety practices.
- 3) Be trained in the proper use and care of protective equipment such as safety shoes, rubber gloves, hard hats, safety glasses, face shields, flash clothing, etc., in accordance with established safety practices.
- 4) Be trained in rendering first aid.
- 5) Be knowledgeable of batteries and the required handling and maintenance precautions.

For further information on workplace safety visit www.osha.gov.

| | |
|--|--|
|  WARNING | |
|  | <p>Misuse of equipment could result in injury and equipment damage.</p> <p>In no event will Toshiba Corporation be responsible or liable for either indirect or consequential damage or injury that may result from the misuse of this equipment.</p> |

|  CAUTION | |
|--|--|
|  | <p>DO NOT dispose of the batteries in a fire. The batteries may explode.</p> |
|  | <p>DO NOT open or mutilate the batteries. Released electrolyte is harmful to the eyes and skin and could also be toxic.</p> |
|  DANGER | |
|  | <p>A battery can present a risk of electrical shock and high short circuit current.</p> |







9.3 Disposal

Please contact your local or state environmental agency for details on disposal of electrical components and packaging in your particular area.

It is illegal to dump lead-acid batteries in landfills or dispose of them improperly.

Please help protect the Earth by contacting the environmental protection agencies in your area, the battery manufacturer, or call Toshiba toll-free at (877) 867-8773 for more information about recycling batteries.

10 Installation

|  WARNING | |
|--|---|
|  | <p>Keep the SPECIFIED CLEARANCE around the UPS.</p> <p>Inadequate space around the UPS makes it difficult to perform maintenance/inspections, lead to insufficient ventilation, and/or will cause malfunctions.</p> <p><i>See Figure 10.1 - UPS Clearance</i></p> |
|  | <p>DO NOT tilt the UPS more than 10° from upright position.</p> <p>Tilting the UPS more than 10° may cause crushing, trapping or other personal injuries.</p> |
|  | <p>Install anchor bolts to secure the UPS to the installation floor.</p> <p>The UPS may fall during an earthquake if the anchor bolts are not installed and secured.</p> |
|  | <p>DO NOT transport, move, store, or place the UPS on its side.</p> <p>Forces due to heavy components inside may damage the UPS.</p> |
|  | <p>DO NOT allow the UPS to suffer shock or impact when unpacking.</p> <p>Tools used to remove packaging materials may cause damage to the UPS.</p> |
|  | <p>DO NOT push or pull on the sides of the packaging or the UPS to move it. Always use a crane, forklift, or pallet jack for transporting and positioning the UPS.</p> <p>Pushing/pulling on the sides of the unit to move it may result in damage to the UPS. See Figure 4.1 Exterior Handling label.</p> |

10.1 Unpacking

Unpack the UPS indoors on a paved floor. The UPS should be as close as possible to its final storage location. Overhead traveling cranes should be used to unpack any G8000 Series UPS. If an overhead traveling crane is not available, allow enough space for forklift operations to unpack the UPS crate. Then remove the crate.

Points to observe

- Retain all small articles during unpacking and installation.
- Make sure that exterior paint is not scratched and that the UPS cabinet is not damaged.
- DO NOT damage the UPS when using tools to remove packaging materials.
- If provided, DO NOT remove the plastic sheet cover, until installation.
- Do not remove the fan covers until UPS start up. The fan covers should be removed by factory authorized personnel. Packing materials should be disposed by the appropriate means.
- Immediately report any abnormalities to Toshiba Customer Support Center or an authorized representative.

10.2 UPS Clearance

Maintain the indicated clearance during installation. See Figure 10.1. Ensure that the front and top air vents are NOT blocked.

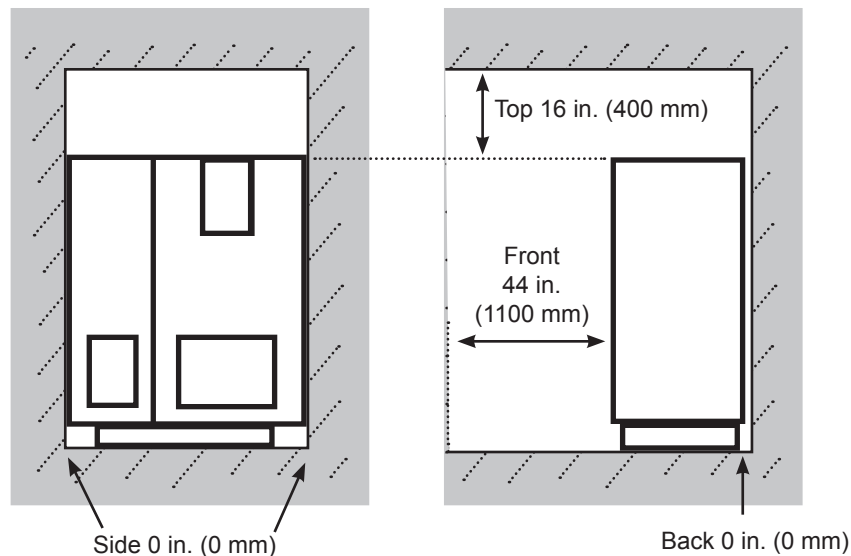

FIGURE 10.1 - UPS CLEARANCE

10.3 Anchor Bolts

Install the anchor bolts to secure the UPS on the floor. See Figure 10.2 for anchor bolt installation detail. Use 12mm (1/2") diameter anchor bolts. There are 16mm (5/8") diameter holes provided in the UPS base. See Figure 10.3 for the hole locations and dimensions for the specified UPS models.

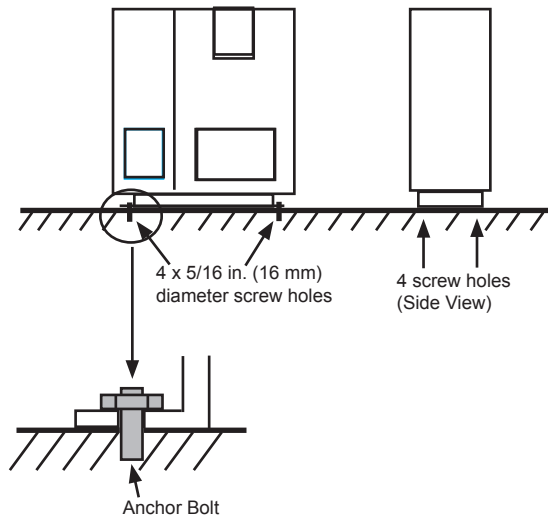

FIGURE 10.2
ANCHOR BOLT INSTALLATION DETAIL

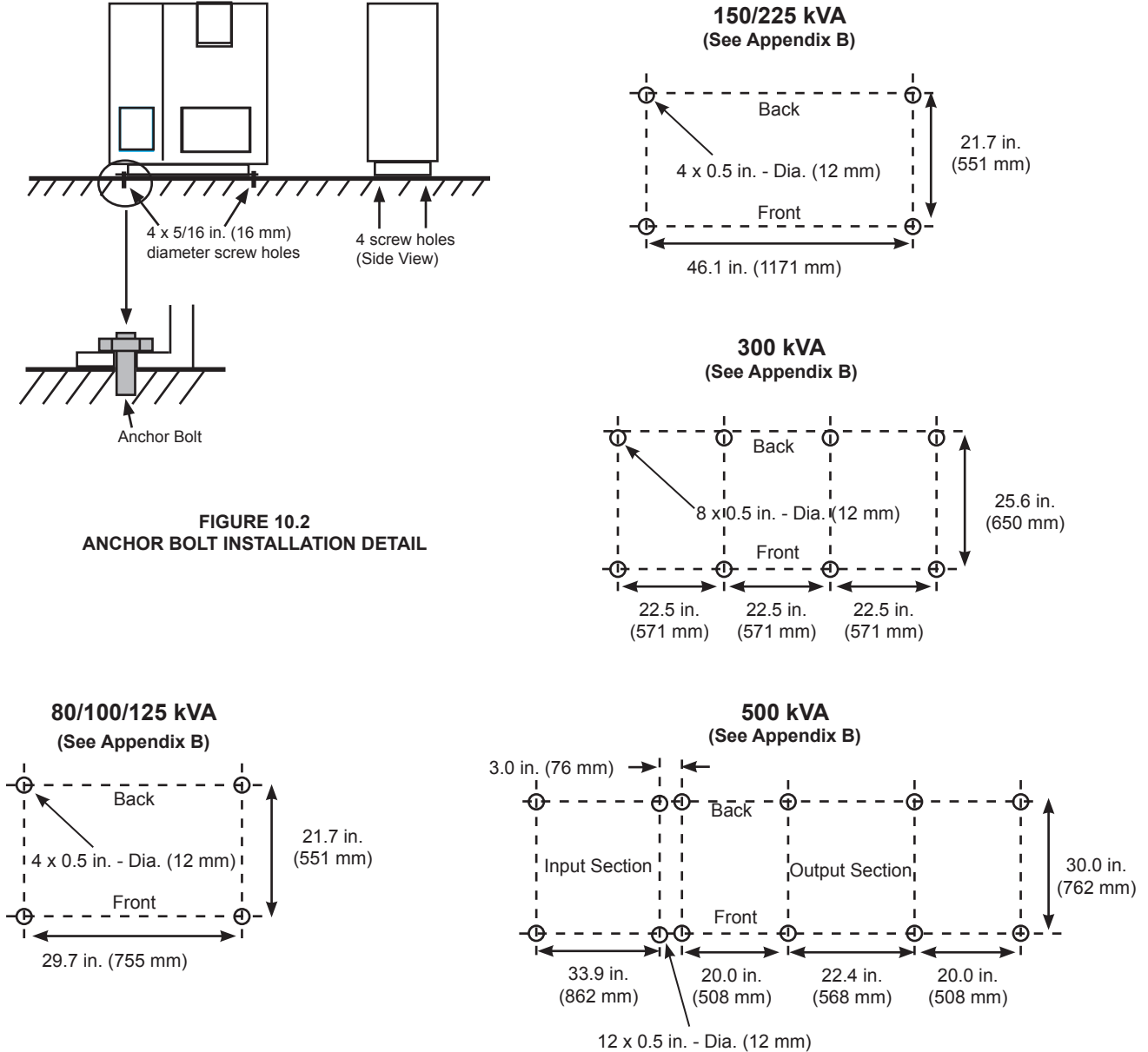

FIGURE 10.3
HOLE LOCATIONS/DIMENSIONS
ON BOTTOM OF UPS

11 UPS Wiring

Note: Always consult your local and NEC electrical codes for wiring, cabling, and circuit protection device requirements.

Figure 11.1 illustrates the external wiring of the single-input G8000 UPS. See corresponding section to each wiring term.

- Power cable connection at terminal blocks/buses and external breaker provision for the AC input/output, Bypass Input and DC input.
- Earth ground wire at grounding terminal.
- Control wire terminal TB1 (battery cabinet and bypass breaker)

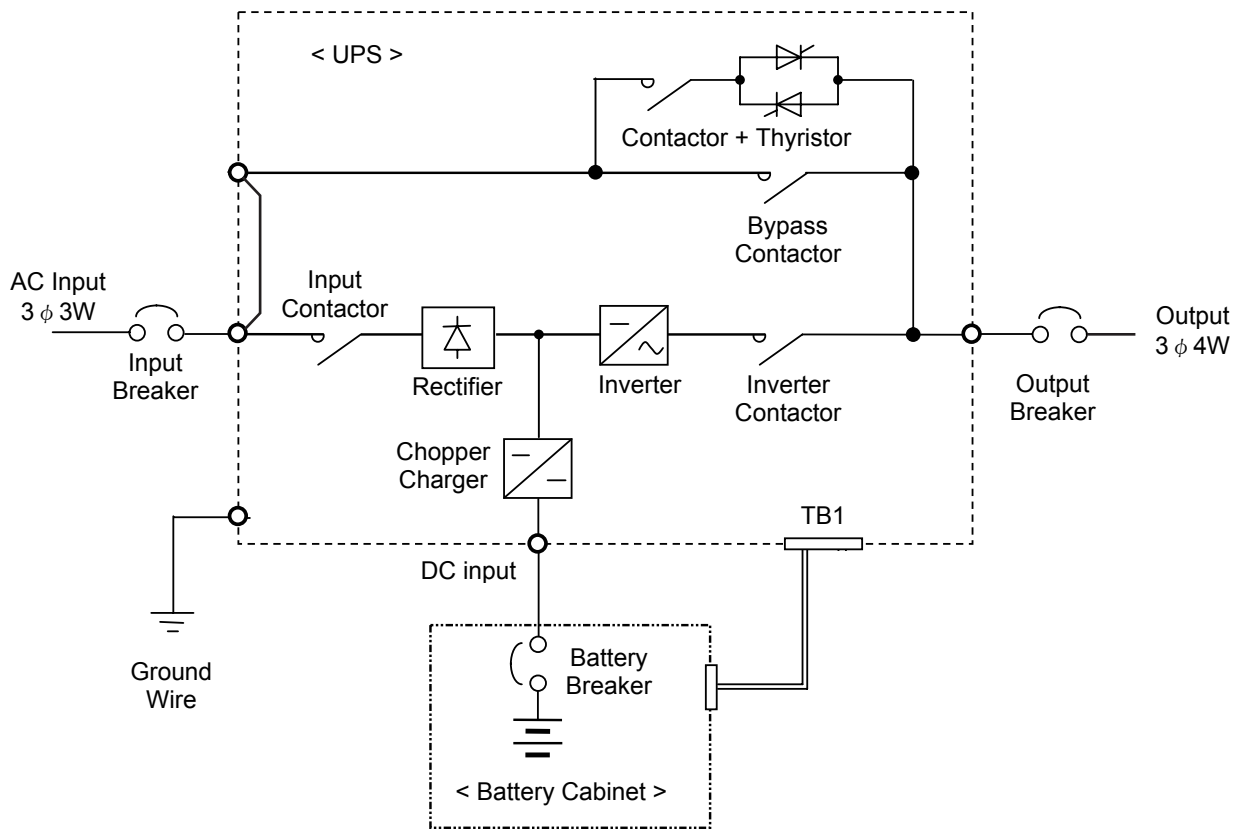

FIGURE 11.1 - SINGLE INPUT EXTERNAL WIRING DIAGRAM

An external maintenance bypass may be installed in parallel with the UPS to allow servicing of the G8000 while maintaining power to the UPS load. Contact the Toshiba Customer Service for further information.

Figure 11.2 illustrates the external wiring of the dual-input G8000 UPS. See corresponding section to each wiring term.

- Power cable connection at terminal blocks/buses and external breaker provision for the AC input/output, Bypass Input and DC input.
- Earth ground wire at grounding terminal.
- Control wire terminal TB1 (battery cabinet and bypass breaker)

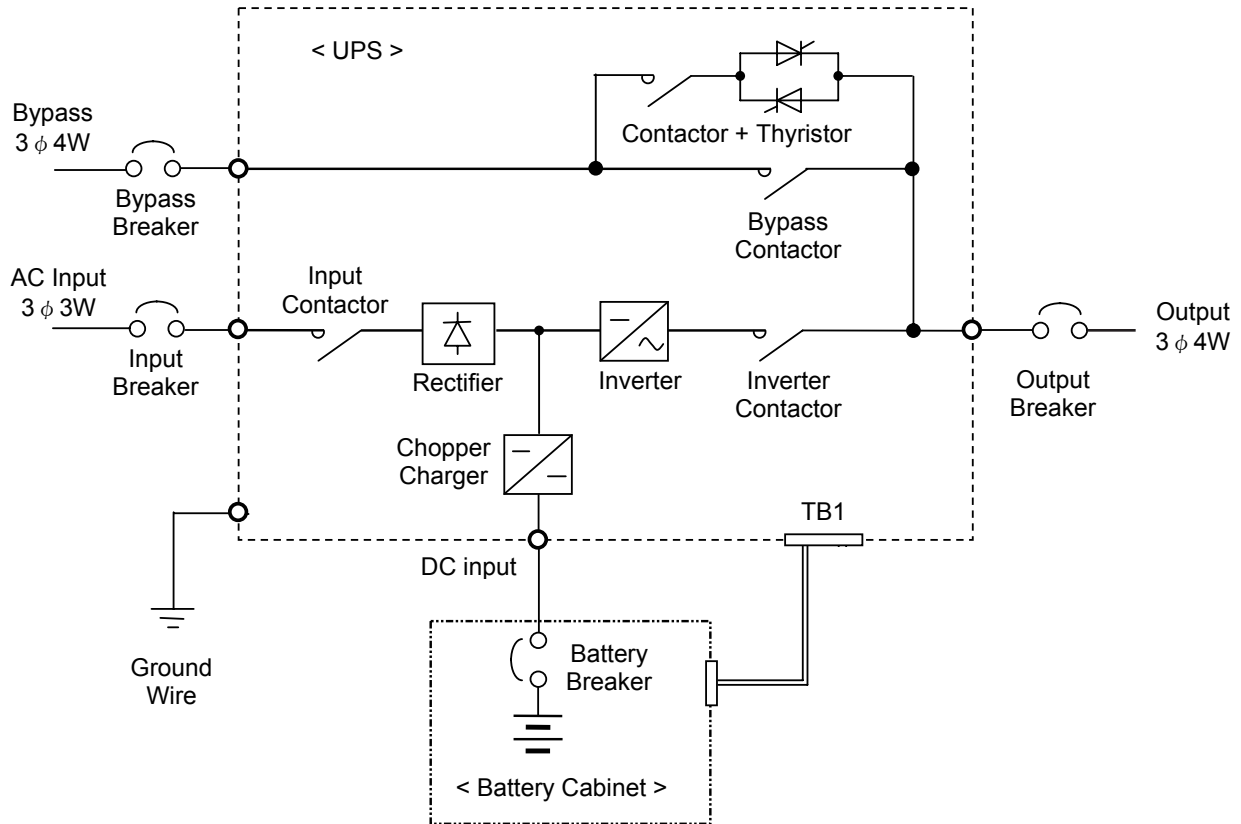

FIGURE 11.2 - DUAL INPUT EXTERNAL WIRING DIAGRAM

An external maintenance bypass may be installed in parallel with the UPS to allow servicing of the G8000 while maintaining power to the UPS load. Contact the Toshiba Customer Service for further information.

11.1 80/100/125 kVA Terminal Blocks and Power Cables

Note: Always consult your site specific, local, state, and NEC electrical codes for wiring, cabling, and circuit protection device requirements.

The terminal blocks for the 80/100/125 kVA UPS are shown in Figure 11.3.

Recommended external cable sizes for both 75 °C and 90 °C copper wire for a single battery string are listed in Table 11.1–11.2. For two or more battery strings consult with Toshiba Technical Support. Ensure that your installation adheres to local and NEC electrical codes.

Use only copper wires for external cables.

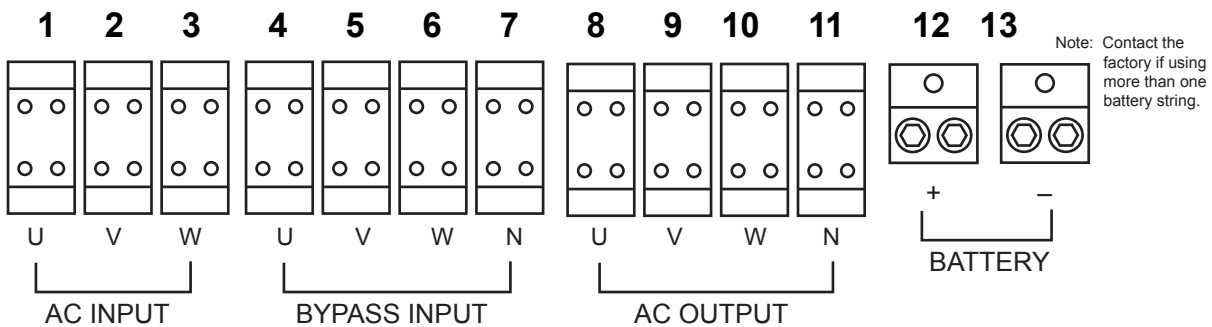

Cable Capacity of Terminal Blocks 1-11: 2 x #6 AWG to 2/0
Cable Capacity of Terminal Blocks 12-13: 2 x #6 AWG to 350 kcmil

FIGURE 11.3 - TERMINAL BLOCKS FOR 80/100/125 KVA UPS

TABLE 11.1 RECOMMENDED CABLE SIZE & TIGHTENING TORQUE FOR 80 KVA UPS

| Block Number | Cable Size (Min-Max) ² | | Tightening Torque |
|-------------------|-----------------------------------|-----------------------|------------------------|
| | 75 °C Copper Wire | 90 °C Copper Wire | |
| 1 | 1/0 – (2) 2/0 AWG | #1 – (2) 2/0 AWG | 50 in.-lb. (5.6 N•m) |
| 2 | 1/0 – (2) 2/0 AWG | #1 – (2) 2/0 AWG | 50 in.-lb. (5.6 N•m) |
| 3 | 1/0 – (2) 2/0 AWG | #1 – (2) 2/0 AWG | 50 in.-lb. (5.6 N•m) |
| 4 | 1/0 – (2) 2/0 AWG | #1 – (2) 2/0 AWG | 50 in.-lb. (5.6 N•m) |
| 5 | 1/0 – (2) 2/0 AWG | #1 – (2) 2/0 AWG | 50 in.-lb. (5.6 N•m) |
| 6 | 1/0 – (2) 2/0 AWG | #1 – (2) 2/0 AWG | 50 in.-lb. (5.6 N•m) |
| 7 ³ | (2) 1/0 – (2) 2/0 AWG | (2) #1 – (2) 2/0 AWG | 50 in.-lb. (5.6 N•m) |
| 8 | 1/0 – (2) 2/0 AWG | #1 – (2) 2/0 AWG | 50 in.-lb. (5.6 N•m) |
| 9 | 1/0 – (2) 2/0 AWG | #1 – (2) 2/0 AWG | 50 in.-lb. (5.6 N•m) |
| 10 | 1/0 – (2) 2/0 AWG | #1 – (2) 2/0 AWG | 50 in.-lb. (5.6 N•m) |
| 11 ³ | (2) 1/0 – (2) 2/0 AWG | (2) #1 – (2) 2/0 AWG | 50 in.-lb. (5.6 N•m) |
| 12 ^{1,2} | (2) 1/0 - (2) 3/0 AWG | (2) 2/0 - (2) 3/0 AWG | 325 in.-lb. (36.7 N•m) |
| 13 ^{1,2} | (2) 1/0 - (2) 3/0 AWG | (2) 2/0 - (2) 3/0 AWG | 325 in.-lb. (36.7 N•m) |

¹ One battery string. (Consult factory if using more than one battery string.)

² Maximum cable size for terminal lugs 1-11: (2) x #6 to #2 AWG; Battery Terminals 12-13: (2) x #6 AWG to 350 kcmil.

³ Cable sized for neutral current=1.7Xphase current. Size cable appropriate to actual load type: balanced, unbalanced, non-linear.

TABLE 11.2 RECOMMENDED CABLE SIZE & TIGHTENING TORQUE FOR 100 KVA UPS

| Block Number | Cable Size (Min-Max) ² | | Tightening Torque |
|-------------------|-----------------------------------|-----------------------|------------------------|
| | 75 °C Copper Wire | 90 °C Copper Wire | |
| 1 | (2) #3 – (2) 2/0 AWG | 2/0 – (2) 2/0 AWG | 50 in.-lb. (5.6 N•m) |
| 2 | (2) #3 – (2) 2/0 AWG | 2/0 – (2) 2/0 AWG | 50 in.-lb. (5.6 N•m) |
| 3 | (2) #3 – (2) 2/0 AWG | 2/0 – (2) 2/0 AWG | 50 in.-lb. (5.6 N•m) |
| 4 | (2) #1 – (2) 2/0 AWG | 2/0 – (2) 2/0 AWG | 50 in.-lb. (5.6 N•m) |
| 5 | (2) #1 – (2) 2/0 AWG | 2/0 – (2) 2/0 AWG | 50 in.-lb. (5.6 N•m) |
| 6 | (2) #1 – (2) 2/0 AWG | 2/0 – (2) 2/0 AWG | 50 in.-lb. (5.6 N•m) |
| 7 ³ | (2) 2/0 AWG | (2) 2/0 AWG | 50 in.-lb. (5.6 N•m) |
| 8 | (2) #1 – (2) 2/0 AWG | 2/0 – (2) 2/0 AWG | 50 in.-lb. (5.6 N•m) |
| 9 | (2) #1 – (2) 2/0 AWG | 2/0 – (2) 2/0 AWG | 50 in.-lb. (5.6 N•m) |
| 10 | (2) #1 – (2) 2/0 AWG | 2/0 – (2) 2/0 AWG | 50 in.-lb. (5.6 N•m) |
| 11 ³ | (2) 2/0 AWG | (2) 2/0 AWG | 50 in.-lb. (5.6 N•m) |
| 12 ^{1,2} | (2) 3/0 - (2) 4/0 AWG | (2) 2/0 - (2) 3/0 AWG | 325 in.-lb. (36.7 N•m) |
| 13 ^{1,2} | (2) 3/0 - (2) 4/0 AWG | (2) 2/0 - (2) 3/0 AWG | 325 in.-lb. (36.7 N•m) |

¹ One battery string. (Consult factory if using more than one battery string.)

² Maximum cable size for terminal lugs 1-11: 2 x 6 to 2/0 AWG; Battery Terminals 12-13: 2 x 6 AWG to 350 kcmil.

³ Cable sized for neutral current=1.7Xphase current. Size cable appropriate to actual load type: balanced, unbalanced, non-linear.

TABLE 11.2 RECOMMENDED CABLE SIZE & TIGHTENING TORQUE FOR 125 KVA UPS

| Block Number | Cable Size (Min-Max) ² | | Tightening Torque |
|-------------------|-----------------------------------|-----------------------|------------------------|
| | 75 °C Copper Wire | 90 °C Copper Wire | |
| 1 | (2) #3 – (2) 2/0 AWG | 2/0 – (2) 2/0 AWG | 50 in.-lb. (5.6 N•m) |
| 2 | (2) #3 – (2) 2/0 AWG | 2/0 – (2) 2/0 AWG | 50 in.-lb. (5.6 N•m) |
| 3 | (2) #3 – (2) 2/0 AWG | 2/0 – (2) 2/0 AWG | 50 in.-lb. (5.6 N•m) |
| 4 | (2) #3 – (2) 2/0 AWG | 2/0 – (2) 2/0 AWG | 50 in.-lb. (5.6 N•m) |
| 5 | (2) #3 – (2) 2/0 AWG | 2/0 – (2) 2/0 AWG | 50 in.-lb. (5.6 N•m) |
| 6 | (2) #3 – (2) 2/0 AWG | 2/0 – (2) 2/0 AWG | 50 in.-lb. (5.6 N•m) |
| 7 ³ | (2) 2/0 AWG | (2) 2/0 AWG | 50 in.-lb. (5.6 N•m) |
| 8 | (2) #3 – (2) 2/0 AWG | 2/0 – (2) 2/0 AWG | 50 in.-lb. (5.6 N•m) |
| 9 | (2) #3 – (2) 2/0 AWG | 2/0 – (2) 2/0 AWG | 50 in.-lb. (5.6 N•m) |
| 10 | (2) #3 – (2) 2/0 AWG | 2/0 – (2) 2/0 AWG | 50 in.-lb. (5.6 N•m) |
| 11 ³ | (2) 2/0 AWG | (2) 2/0 AWG | 50 in.-lb. (5.6 N•m) |
| 12 ^{1,2} | (2) 3/0 - (2) 4/0 AWG | (2) 2/0 - (2) 3/0 AWG | 325 in.-lb. (36.7 N•m) |
| 13 ^{1,2} | (2) 3/0 - (2) 4/0 AWG | (2) 2/0 - (2) 3/0 AWG | 325 in.-lb. (36.7 N•m) |

¹ One battery string. (Consult factory if using more than one battery string.)

² Maximum cable size for terminal lugs 1-11: 2 x 6 to 2/0 AWG; Battery Terminals 12-13: 2 x 6 AWG to 350 kcmil.

³ Cable sized for neutral current=1.7Xphase current. Size cable appropriate to actual load type: balanced, unbalanced, non-linear.

11.2 150, 225, 300, and 500 kVA Buss Strip Terminals and Power Cables

Note: Always consult your site specific, local, state, and NEC electrical codes for wiring, cabling, and circuit protection device requirements.

The 150, 225, 300 and 500 kVA UPS units have buss strip power terminals.

Figure 11.4 is a typical buss strip for a 150/225 kVA UPS.

Figure 11.5 shows the arrangement of the terminal buss strips for the 150 and 225 kVA UPS units. The terminal buss strips are located inside, at the bottom of the UPS. The dashed line on terminals 1–13 indicates the side view of the bolt holes. Use 1/2 inch bolts to attach the lugs.

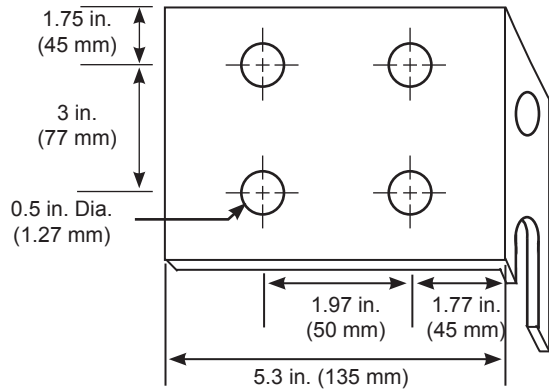
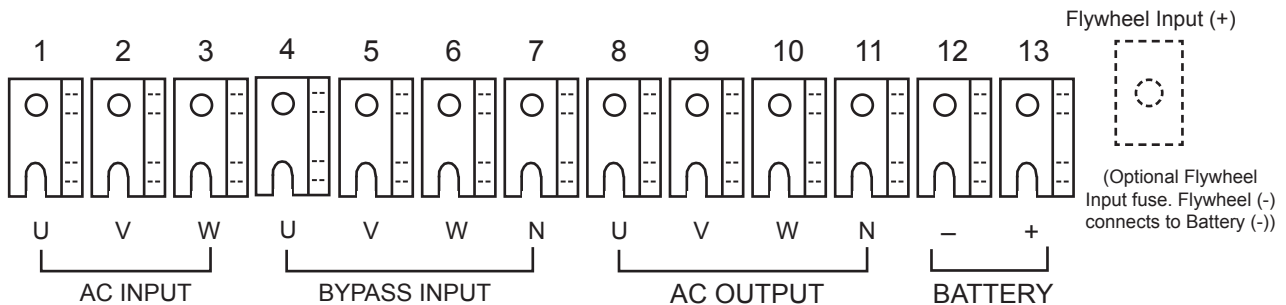

FIGURE 11.4 - TERMINAL BUS DETAIL



Note: Contact the factory if using more than one battery string, flywheel, or combination battery and flywheel.

FIGURE 11.5 - TERMINAL BUSS ARRANGEMENT FOR 150 AND 225 KVA UPS

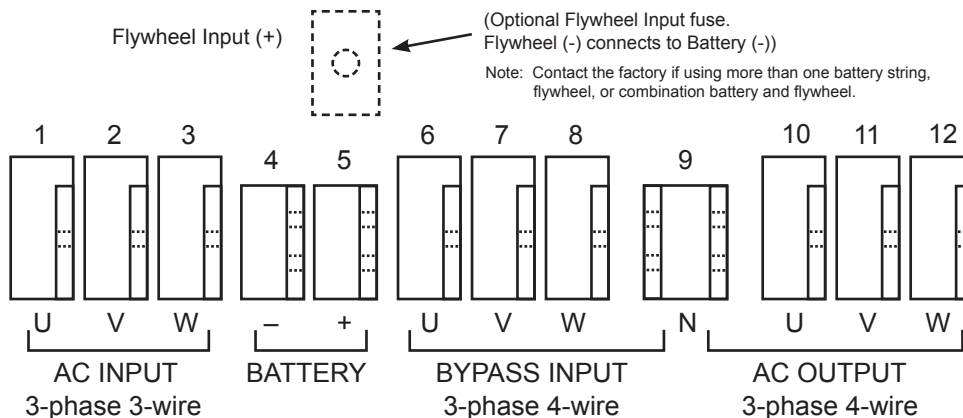

FIGURE 11.6 - TERMINAL BUSS ARRANGEMENT FOR 300 KVA UPS

Figure 11.7 shows the terminal mounting hole arrangement for the terminal buss strips for the 500 kVA UPS units.

Figure 11.8 shows the arrangement of the terminal buss strips for the 500 kVA UPS. The buss strips are located inside at the top of the unit. The dashed line on terminals 1–13 indicates the side view of the bolt holes. Use 1/2 inch bolts to attach the lugs.

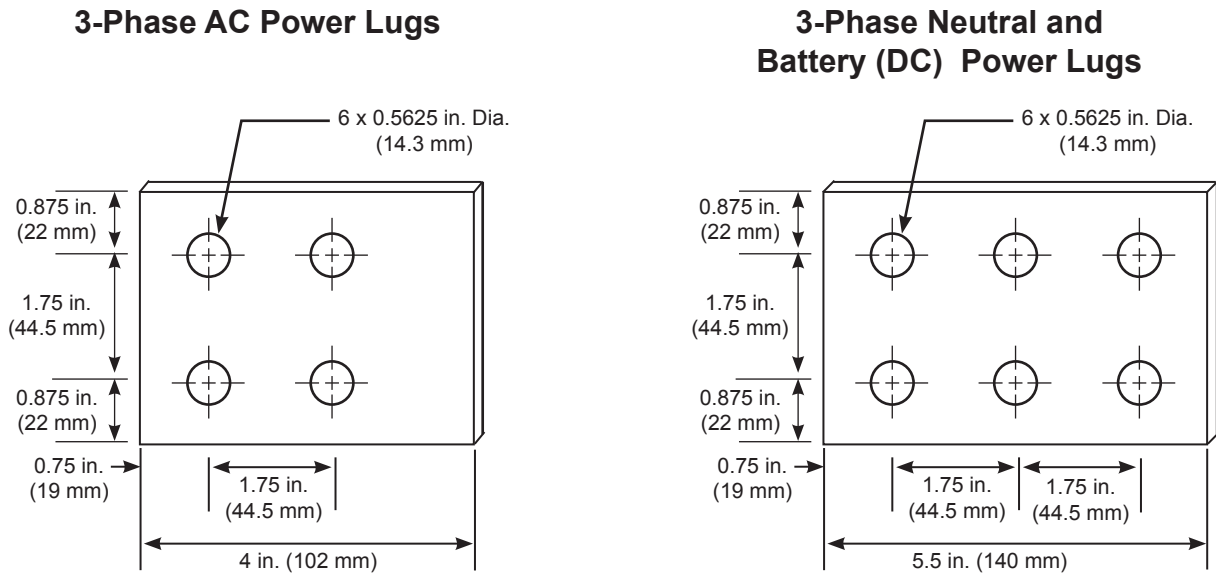

FIGURE 11.7 - TERMINAL BUSS DETAILS FOR 500KVA UPS

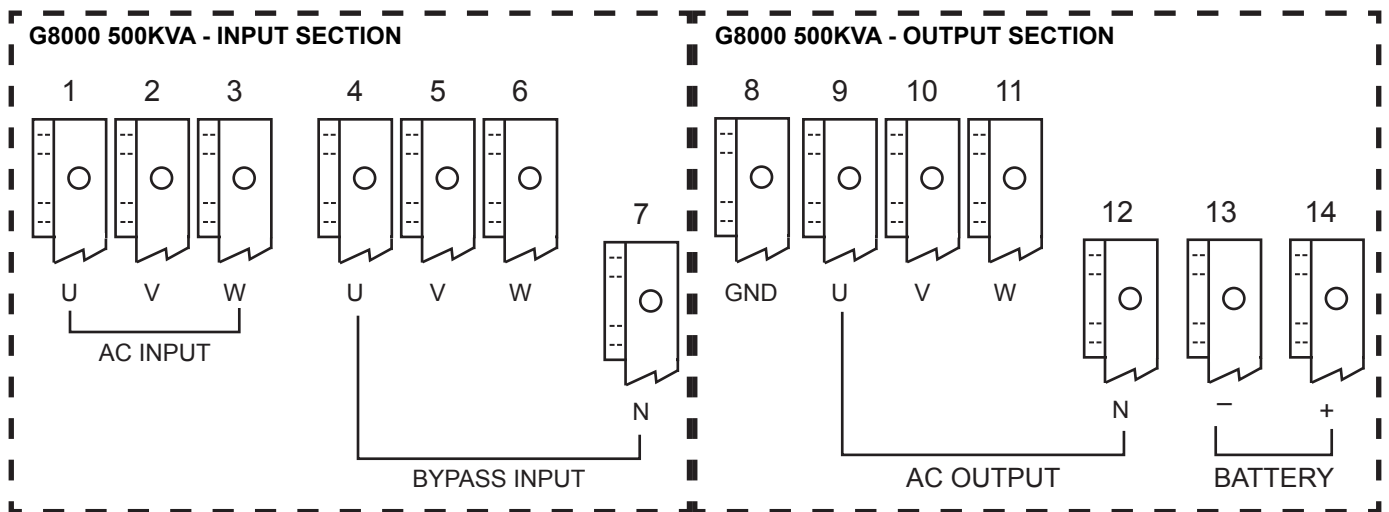

FIGURE 11.8 - TERMINAL BUSS ARRANGEMENT FOR 500 KVA UPS

For UPS' equipped with buss strip terminals for the A/C INPUT, BYPASS INPUT, A/C OUTPUT and BATTERY connections, Toshiba recommends using the compression lugs listed in Table 11.3, or their equivalent, for cable terminations to be mounted on the bus strips.

See Table 11.5 – Table 11.6 for recommended cable sizes for the 150, 225, 300 and 500 kVA UPS.

TABLE 11.3 RECOMMENDED CRIMP TYPE COMPRESSION LUGS FOR BUS STRIP TERMINALS

| Wire Size | Wire Strand Class | Recommendation | | Crimp tool Required Burndy type Y35 or Y46 | |
|-----------|-------------------|----------------|----------|---|-----------|
| | | Vendor | Cat. No. | Color Key | Die Index |
| 1/0 | B | Burndy | YA25 | Pink | 12 / 348 |
| | I | IlSCO | CRA-1/OL | Pink | 12 / 348 |
| | B | Burndy | YA25-LB | Black | 13 |
| 2/0 | B | Burndy | YA26 | Black | 13 |
| | I | IlSCO | CRA-2/OL | Black | 13 |
| | B | Burndy | YA27-LB | Orange | 14 / 101 |
| 3/0 | B | Burndy | YA-27 | Orange | 14 / 101 |
| | I | IlSCO | CRB-3/OL | Orange | 14 / 101 |
| | B | Burndy | YA28-LB | Purple | 15 |
| 4/0 | B | Burndy | YA28 | Purple | 15 |
| | I | IlSCO | CRB-4/OL | Purple | 15 |
| | B | Burndy | YA29-LB | Yellow | 16 |
| 300 MCM | B | Burndy | YA30 | White | 17 / 298 |
| | I | IlSCO | CRA-30OL | White | 17 / 298 |
| | B | Burndy | YA32-LB | Red | 18 / 324 |
| 350 MCM | B | Burndy | YA31L | Red | 18 |
| | I | IlSCO | CRA-350 | Red | 18 |
| 600 MCM | B | Burndy | YA36L | Green | 22 |
| | I | IlSCO | CRA-600 | Green | 22 |

**TABLE 11.4 RECOMMENDED CABLE SIZE AND FASTENER TORQUE FOR 150 KVA UNIT
(USE 75 °C Copper Wire)**

Recommended external cable sizes for both 75 °C and 90 °C copper wire for minimum battery configurations are listed in Table 11.4–11.7. For extended runtime battery strings configurations consult with Toshiba Technical Support. Ensure that your installation adheres to local and NEC electrical codes.

**TABLE 11.4 RECOMMENDED CABLE SIZE AND FASTENER TORQUE FOR 150 KVA UNIT
(USE 75 °C Copper Wire)**

| Block Number | Cable Size (Min-Max) | | Tightening Torque ² |
|---------------------------------|------------------------------|-------------------------------|--------------------------------|
| | 75 °C Copper Wire | 90 °C Copper Wire | |
| 1 | 300 kcmil – (2) #1 AWG | 250 kcmil – (2) #1 AWG | 540 in.-lb. (61 N•m) |
| 2 | 300 kcmil – (2) #1 AWG | 250 kcmil – (2) #1 AWG | 540 in.-lb. (61 N•m) |
| 3 | 300 kcmil – (2) #1 AWG | 250 kcmil – (2) #1 AWG | 540 in.-lb. (61 N•m) |
| 4 | 300 kcmil – (2) #1 AWG | 250 kcmil – (2) #1 AWG | 540 in.-lb. (61 N•m) |
| 5 | 300 kcmil – (2) #1 AWG | 250 kcmil – (2) #1 AWG | 540 in.-lb. (61 N•m) |
| 6 | 300 kcmil – (2) #1 AWG | 250 kcmil – (2) #1 AWG | 540 in.-lb. (61 N•m) |
| 7 ⁴ | (2) 300 kcmil – (6) #1 AWG | (2) 250 kcmil – (6) #1 AWG | 540 in.-lb. (61 N•m) |
| 8 | 300 kcmil – (2) #1 AWG | 250 kcmil – (2) #1 AWG | 540 in.-lb. (61 N•m) |
| 9 | 300 kcmil – (2) #1 AWG | 250 kcmil – (2) #1 AWG | 540 in.-lb. (61 N•m) |
| 10 | 300 kcmil – (2) #1 AWG | 250 kcmil – (2) #1 AWG | 540 in.-lb. (61 N•m) |
| 11 ⁴ | (2) 300 kcmil – (6) #1 AWG | (2) 250 kcmil – (6) #1 AWG | 540 in.-lb. (61 N•m) |
| 12 ¹ | (2) 300 kcmil– (2) 350 kcmil | (2) 250 kcmil – (2) 350 kcmil | 540 in.-lb. (61 N•m) |
| 13 ¹ | (2) 300 kcmil– (2) 350 kcmil | (2) 250 kcmil – (2) 350 kcmil | 540 in.-lb. (61 N•m) |
| Flywheel Input (+) ³ | (2) AWG 2/0 | (2) AWG 2/0 | 300 in.-lb. (33.9 N•m) |

¹ One battery string. (Consult factory if using more than one battery string.)

² Fastener torque specified for: 1/2 in. diameter grade 5 steel bolt.

³ Per flywheel unit

⁴ Cable sized for neutral current=1.7Xphase current. Size cable appropriate to actual load type: balanced, unbalanced, non-linear.

**TABLE 11.5 RECOMMENDED CABLE SIZE AND FASTENER TORQUE FOR 225 KVA UNIT
(USE 75 °C Copper Wire)**

| Block Number | Cable Size (Min-Max) | | Tightening Torque ² |
|---------------------------------|-------------------------|-------------------------|--------------------------------|
| | 75 °C Copper Wire | 90 °C Copper Wire | |
| 1 | (2) 3/0– (2) 4/0 AWG | (2) 2/0– (2) 3/0 AWG | 540 in.-lb. (61 N•m) |
| 2 | (2) 3/0– (2) 4/0 AWG | (2) 2/0– (2) 3/0 AWG | 540 in.-lb. (61 N•m) |
| 3 | (2) 3/0– (2) 4/0 AWG | (2) 2/0– (2) 3/0 AWG | 540 in.-lb. (61 N•m) |
| 4 | (2) 4/0– (2) 250 kcmil | (2) 3/0– (2) 4/0 AWG | 540 in.-lb. (61 N•m) |
| 5 | (2) 4/0– (2) 250 kcmil | (2) 3/0– (2) 4/0 AWG | 540 in.-lb. (61 N•m) |
| 6 | (2) 4/0– (2) 250 kcmil | (2) 3/0– (2) 4/0 AWG | 540 in.-lb. (61 N•m) |
| 7 ⁴ | (4) 4/0– (4) 250 kcmil | (4) 3/0 – (4) 4/0 AWG | 540 in.-lb. (61 N•m) |
| 8 | (2) 4/0– (2) 250 kcmil | (2) 3/0– (2) 4/0 AWG | 540 in.-lb. (61 N•m) |
| 9 | (2) 4/0– (2) 250 kcmil | (2) 3/0– (2) 4/0 AWG | 540 in.-lb. (61 N•m) |
| 10 | (2) 4/0– (2) 250 kcmil | (2) 3/0– (2) 4/0 AWG | 540 in.-lb. (61 N•m) |
| 11 ⁴ | (4) 4/0– (4) 250 kcmil | (4) 3/0 – (4) 4/0 AWG | 540 in.-lb. (61 N•m) |
| 12 ¹ | (4) 4/0 – (4) 250 kcmil | (3) 250 kcmil – (4) 3/0 | 540 in.-lb. (61 N•m) |
| 13 ¹ | (4) 4/0 – (4) 250 kcmil | (3) 250 kcmil – (4) 3/0 | 540 in.-lb. (61 N•m) |
| Flywheel Input (+) ³ | (2) AWG 2/0 | (2) AWG 2/0 | 300 in.-lb. (33.9 N•m) |

¹ One battery string. (Consult factory if using more than one battery string.)

² Fastener torque specified for: 1/2 in. diameter grade 5 steel bolt.

³ Per flywheel unit

⁴ Cable sized for neutral current=1.7Xphase current. Size cable appropriate to actual load type: balanced, unbalanced, non-linear.

TABLE 11.6 RECOMMENDED CABLE SIZE AND FASTENER TORQUE FOR 300 KVA UPS

| Bus Number | Cable Size (Min-Max) | | Tightening Torque ² |
|---------------------------------|-------------------------------|-------------------------------|--------------------------------|
| | 75 °C Copper Wire | 90 °C Copper Wire | |
| 1 | (2) 250 kcmil – (3) 2/0 | (2) 4/0 – (3) 1/0 | 540 in.-lb. (61 N•m) |
| 2 | (2) 250 kcmil – (3) 2/0 | (2) 4/0 – (3) 1/0 | 540 in.-lb. (61 N•m) |
| 3 | (2) 250 kcmil – (3) 2/0 | (2) 4/0 – (3) 1/0 | 540 in.-lb. (61 N•m) |
| 4 ¹ | (4) 300 kcmil – (4) 350 kcmil | (4) 300 kcmil – (4) 350 kcmil | 540 in.-lb. (61 N•m) |
| 5 ¹ | (4) 300 kcmil – (4) 350 kcmil | (4) 300 kcmil – (4) 350 kcmil | 540 in.-lb. (61 N•m) |
| 6 | (2) 300 kcmil – (3) 2/0 | (2) 250 kcmil – (3) 1/0 | 540 in.-lb. (61 N•m) |
| 7 | (2) 300 kcmil – (3) 2/0 | (2) 250 kcmil – (3) 1/0 | 540 in.-lb. (61 N•m) |
| 8 | (2) 300 kcmil – (3) 2/0 | (2) 250 kcmil – (3) 1/0 | 540 in.-lb. (61 N•m) |
| 9 ⁴ | (2) 300 kcmil – (3) 2/0 | (2) 250 kcmil – (3) 1/0 | 540 in.-lb. (61 N•m) |
| 10 | (2) 300 kcmil – (3) 2/0 | (2) 250 kcmil – (3) 1/0 | 540 in.-lb. (61 N•m) |
| 11 | (4) 300 kcmil – (4) 350 kcmil | (4) 250 kcmil – (4) 300 kcmil | 540 in.-lb. (61 N•m) |
| 12 | (4) 300 kcmil – (4) 350 kcmil | (4) 250 kcmil – (4) 300 kcmil | 540 in.-lb. (61 N•m) |
| Flywheel Input (+) ³ | (2) AWG 2/0 | (2) AWG 2/0 | 300 in.-lb. (33.9 N•m) |

¹ One battery string. (Consult factory if using more than one battery string.)

² Fastener torque specified for: 1/2 in. diameter grade 5 steel bolt.

³ Per flywheel unit

⁴ Cable sized for neutral current=1.7Xphase current. Size cable appropriate to actual load type: balanced, unbalanced, non-linear.

TABLE 11.7 RECOMMENDED CABLE SIZE AND FASTENER TORQUE FOR 500 KVA UPS

| Bus Number | Cable Size (Min-Max) | | Tightening Torque ¹ |
|-----------------|-------------------------------|-------------------------------|--------------------------------|
| | 75 °C Copper Wire | 90 °C Copper Wire | |
| 1 | (3) 250 kcmil – (3) 400 kcmil | (3) 4/0 kcmil – (3) 250 kcmil | 540 in.-lb. (61 N•m) |
| 2 | (3) 250 kcmil – (3) 400 kcmil | (3) 4/0 kcmil – (3) 250 kcmil | 540 in.-lb. (61 N•m) |
| 3 | (3) 250 kcmil – (3) 400 kcmil | (3) 4/0 kcmil – (3) 250 kcmil | 540 in.-lb. (61 N•m) |
| 4 | (3) 400 kcmil – (3) 500 kcmil | (4) 400 kcmil – (4) 500 kcmil | 540 in.-lb. (61 N•m) |
| 5 | (3) 400 kcmil – (3) 500 kcmil | (4) 400 kcmil – (4) 500 kcmil | 540 in.-lb. (61 N•m) |
| 6 | (3) 400 kcmil – (3) 500 kcmil | (3) 400 kcmil – (3) 500 kcmil | 540 in.-lb. (61 N•m) |
| 7 ² | (6) 400 kcmil – (6) 500 kcmil | (3) 400 kcmil – (3) 500 kcmil | 540 in.-lb. (61 N•m) |
| 8 ³ | 1/0 | 1/0 | 540 in.-lb. (61 N•m) |
| 9 | (3) 400 kcmil – (3) 500 kcmil | (3) 400 kcmil – (3) 500 kcmil | 540 in.-lb. (61 N•m) |
| 10 | (3) 400 kcmil – (3) 500 kcmil | (3) 400 kcmil – (3) 500 kcmil | 540 in.-lb. (61 N•m) |
| 11 | (3) 400 kcmil – (3) 500 kcmil | (3) 400 kcmil – (3) 500 kcmil | 540 in.-lb. (61 N•m) |
| 12 ² | (6) 400 kcmil – (6) 500 kcmil | (3) 400 kcmil – (3) 500 kcmil | 540 in.-lb. (61 N•m) |
| 13 | (3) 400 kcmil – (3) 500 kcmil | (3) 400 kcmil – (3) 500 kcmil | 540 in.-lb. (61 N•m) |
| 14 | (3) 400 kcmil – (3) 500 kcmil | (3) 400 kcmil – (3) 500 kcmil | 540 in.-lb. (61 N•m) |

¹ Fastener torque specified for: 1/2 in. diameter grade 5 steel bolt.

² Cable sized for neutral current=1.7Xphase current. Size cable appropriate to actual load type: balanced, unbalanced, non-linear.

³ Ground cables

11.3 UPS Power Cable Conduit Landing Plates

Cable conduit landing plates are provided at the bottom of the 80 kVA and 100 kVA UPS, at the top and bottom of the 150/225 kVA UPS (Older models of the G8000 150/225 kVA UPS do not come equipped with an upper conduit landing plate.), and at the top only of the 300/500kVA. The recommended conduit landing arrangements are illustrated in Figure 11.9 thru 11.13.

The five (5) holes must be punched during installation. The dashed rectangle indicates the UPS opening behind the conduit landing plates.

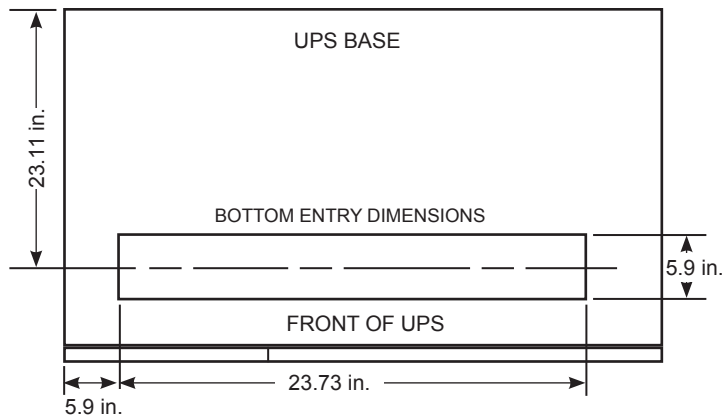
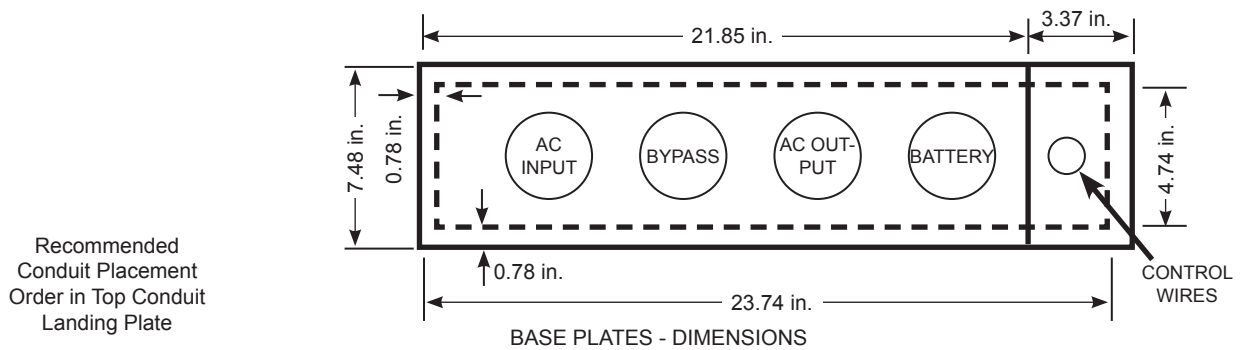

FIGURE 11.9 - BOTTOM CONDUIT LANDING PLATES FOR 80/100/125 KVA

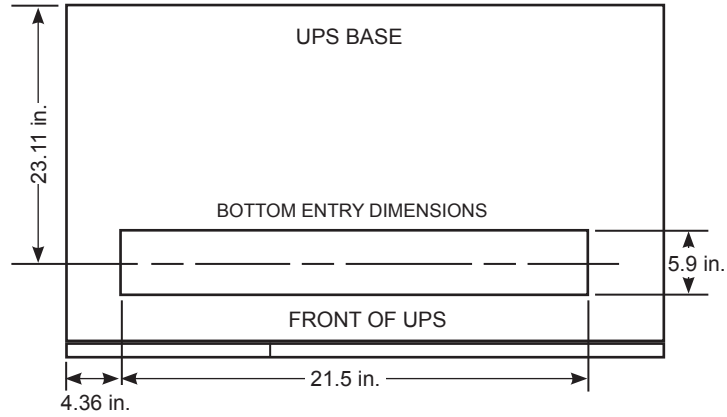
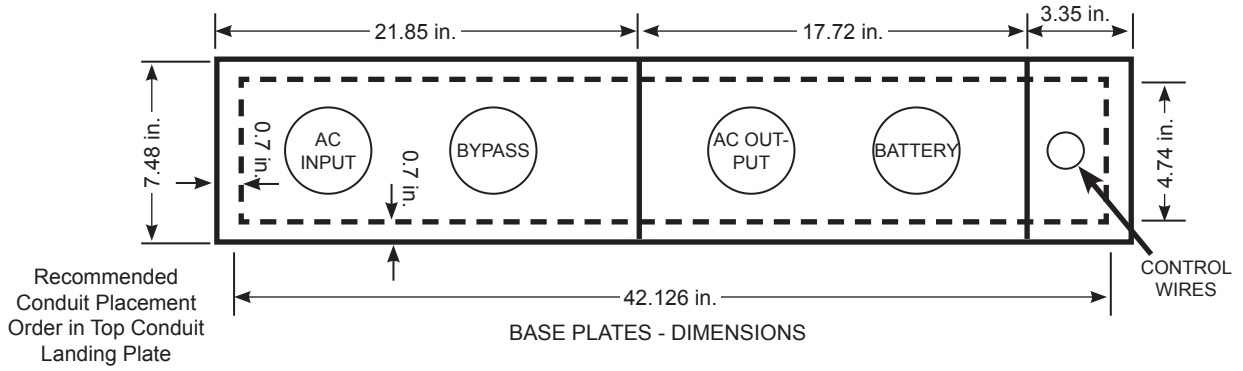

FIGURE 11.10 - BOTTOM CONDUIT LANDING PLATES 100 KVA (T80S3K10KK6XSNH); 150/225 KVA

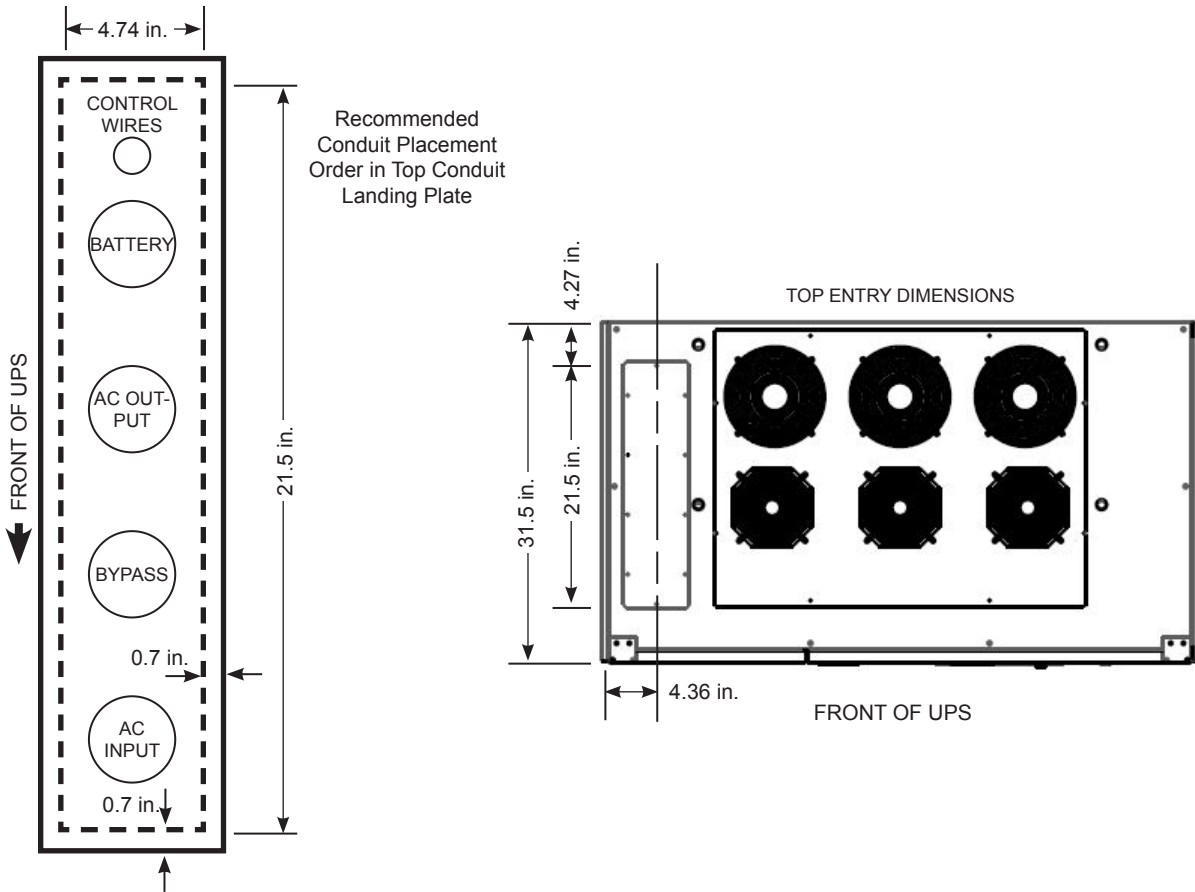

FIGURE 11.11 - TOP ACCESS CONDUIT LANDING PLATE (150 AND 225 KVA ONLY)

Figure 11.12 shows the four (4) cable landing plates provided at the top of the 300 kVA UPS. Seven (7) holes must be punched during installation. The dashed rectangle indicates the UPS opening behind the conduit landing plates.

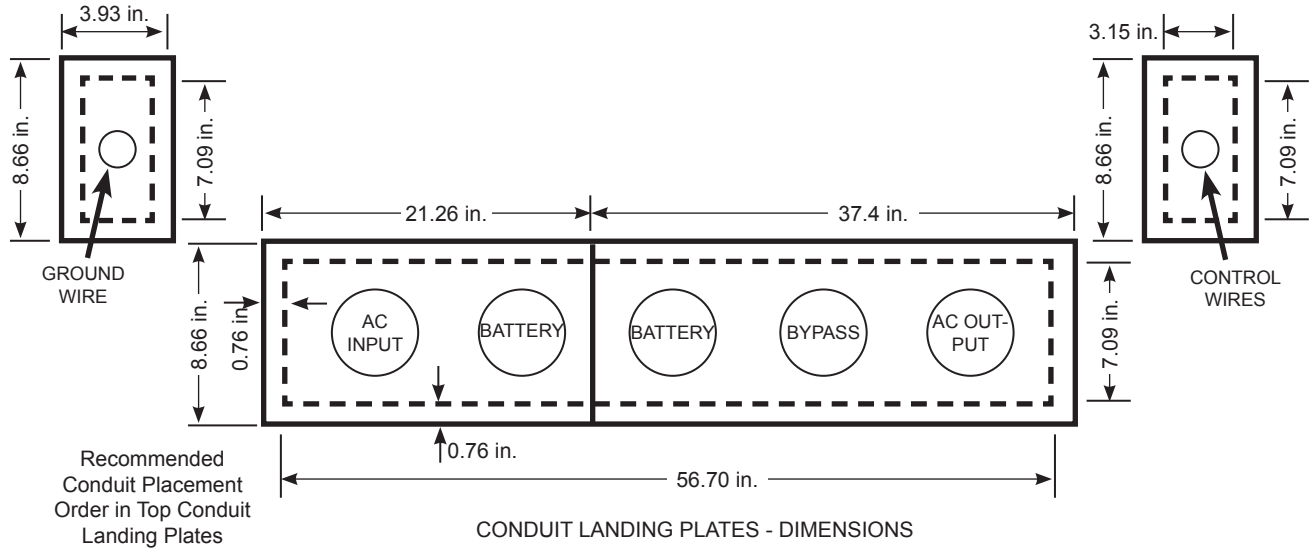

FIGURE 11.12 - TOP ACCESS CONDUIT LANDING PLATES (300 KVA)

Figure 11.13 shows the three (3) conduit landing plates provided at the top of the 500 kVA UPS. The dashed rectangle indicates the UPS opening behind the conduit landing plates.

Ensure that your installation adheres to local and NEC electrical codes.

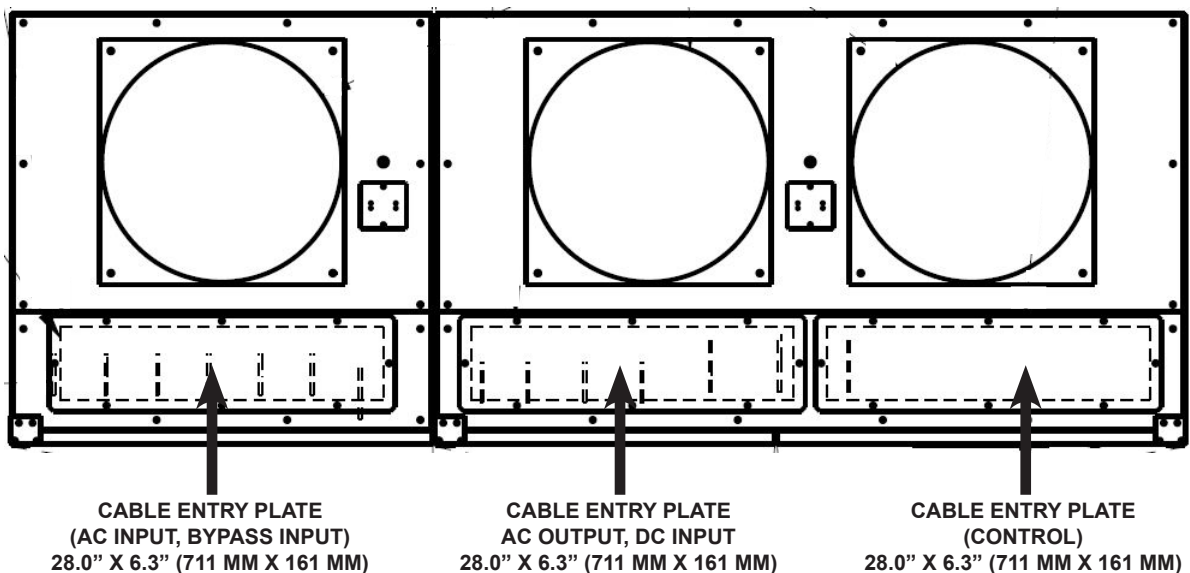

FIGURE 11.13 - TOP CONDUIT LANDING PLATES FOR THE 500 KVA UPS

11.4 External Breakers

The G8000 UPS units are not equipped with circuit breakers. Qualified personnel should provide the external breakers for the AC input/output, bypass input and DC input.

See Figure 11.1 – External Wiring Diagram, for the circuit position of the breakers.

Table 11.7 shows the G8000 UPS minimum external breaker rating for each capacity. The Bypass, AC Input, and AC Output require 3-pole breakers.

TABLE 11.7 UPS MINIMUM DEVICE RATINGS

| CAPACITY | RATED OUTPUT | INPUT BREAKER RATING | OUTPUT BREAKER RATING | DC INPUT BREAKER RATING |
|----------|--------------|----------------------|-----------------------|-------------------------|
| 80 kVA | 480 V/277 V | 480 V – 150 A | 480 V – 125 A | 500 VDC – 300A |
| 100 kVA | 480 V/277 V | 480 V – 200 A | 480 V – 150 A | 500 VDC – 350A |
| 125 kVA | 480 V/277 V | 480 V – 200 A | 480 V – 200 A | 500 VDC – 400A |
| 150 kVA | 480 V/277 V | 480 V – 300 A | 480 V – 250 A | 500 VDC – 600A |
| 225 kVA | 480 V/277 V | 480 V – 400 A | 480 V – 350 A | 500 VDC – 900A |
| 300 kVA | 480 V/277 V | 480 V – 600 A | 480 V – 500 A | 500 VDC – 1200A |
| 500 kVA | 480 V/277 V | 480 V – 800 A | 480 V – 800 A | 600 VDC – 1200A |

11.5 Grounding Wire

 **WARNING**



Be sure to ground the UPS as specified.

Using the UPS without a proper ground will deteriorate the insulation, cause leakage of currents and electric shock. The resistance to ground should be less than or equal to 10 ohms.

The 80/100/150/225kVA earth grounding bus' are located inside, at the bottom-front of the unit.

The 300 kVA earth grounding bus is located inside, at the top-left of the unit.

The 500 kVA earth grounding bus is located inside, at the bottom front of the units.

Use a AWG 2 (or 38 mm²) or larger cable for the grounding wire. Run the grounding wire through the opening at the bottom, or through a hole in the top conduit landing plate (if available). See Figure 11.12. Connect either the top or bottom earth ground bus, but not both, to the grounding wire.

The ground wire must have a crimp terminal with a 1/2 in. (12 mm) diameter bolt hole. The ground bus has 3/64 in. (13 mm) bolt hole. The connect the crimp terminal and ground bus together using a 7/16 in. (10 mm) diameter bolt.

G8000 - 80/100 kVA

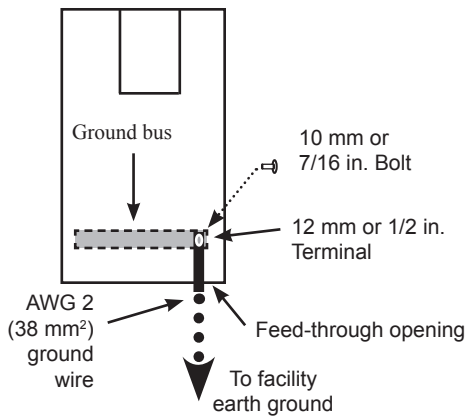

G8000 - 300 kVA

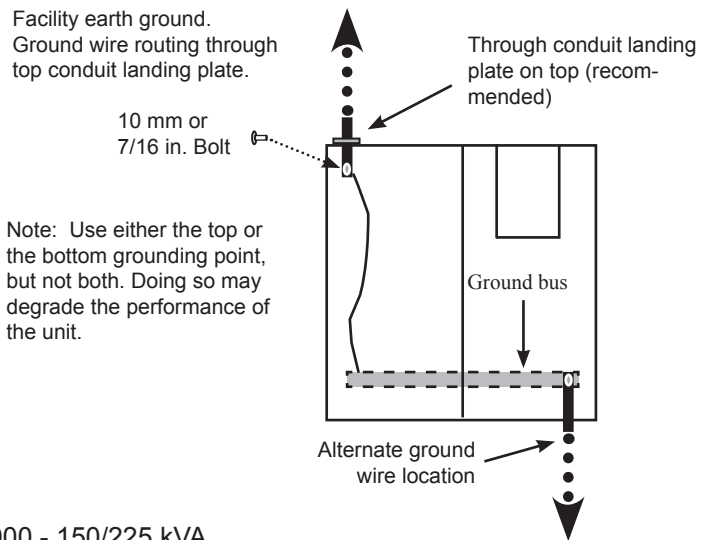

G8000 - 150/225 kVA

Facility earth ground.
Alternate ground wire routing
through top conduit landing
plate.

Note: Use either the top
or the bottom access for
the ground wire to connect
to the ground buss, but
use only one ground wire.

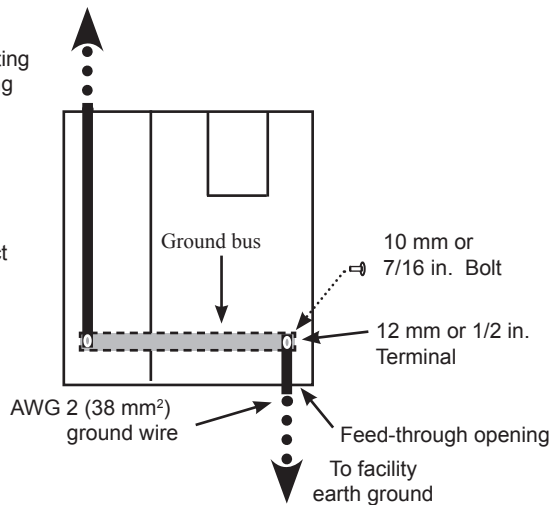

G8000 - 500 kVA

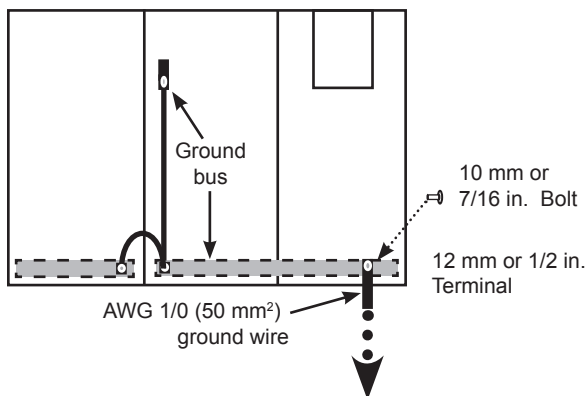

FIGURE 11.14 - EARTH GROUND WIRE CONNECTIONS

11.6 Control Wires

The control wires terminal layouts at TB1 (terminal bus 1) are shown below in Table 11.8.

TABLE 11.8 EXTERNAL CONNECTIONS

| No. | I/O | Signal Name | Operation |
|-----|--------|-------------------------|--|
| 1 | Output | Low Battery | Closed at Low Battery |
| 2 | Output | Backup Operation | Closed during Backup Operation |
| 3 | Output | Fault | Closed if Faults present |
| 4 | Output | Inverter Supply | Closed during Normal Operation |
| 5 | Output | Warning | Closed if Warnings present |
| 6 | Input | P24 Remote Run | Close to run UPS |
| 7 | Input | | |
| 8 | Input | P24 Remote Stop | Close to stop UPS |
| 9 | Input | | |
| 10 | Output | Bypass Supply | Close during Bypass Operation |
| 11 | Output | Output Signal Ground | (Ground for pin #1 – 5 & #10) |
| 12 | Input | P24 Battery Overheat | Battery's Overheat B-contact |
| 13 | Input | | |
| 14 | Output | 52C Trip Signal | Bypass Breaker Shunt Trip Signal by EPO |
| 15 | Output | | |
| 16 | Output | 72B Trip Signal | Battery Breaker shunt trip by EPO or Battery shutdown |
| 17 | Output | | |
| 18 | Output | 72B Aux. Contact | Battery breaker's Auxiliary A-contact |
| 19 | Output | | |
| 20 | | | |
| 21 | Output | External EPO | Ext EPO (Customer) N.O. Contacts |
| 22 | Output | | |

Note: All control wiring should be #18 AWG (0.823 mm²) or larger.

The UPS battery cabinet and bypass breaker should be wired as shown below in Figure 11.15.

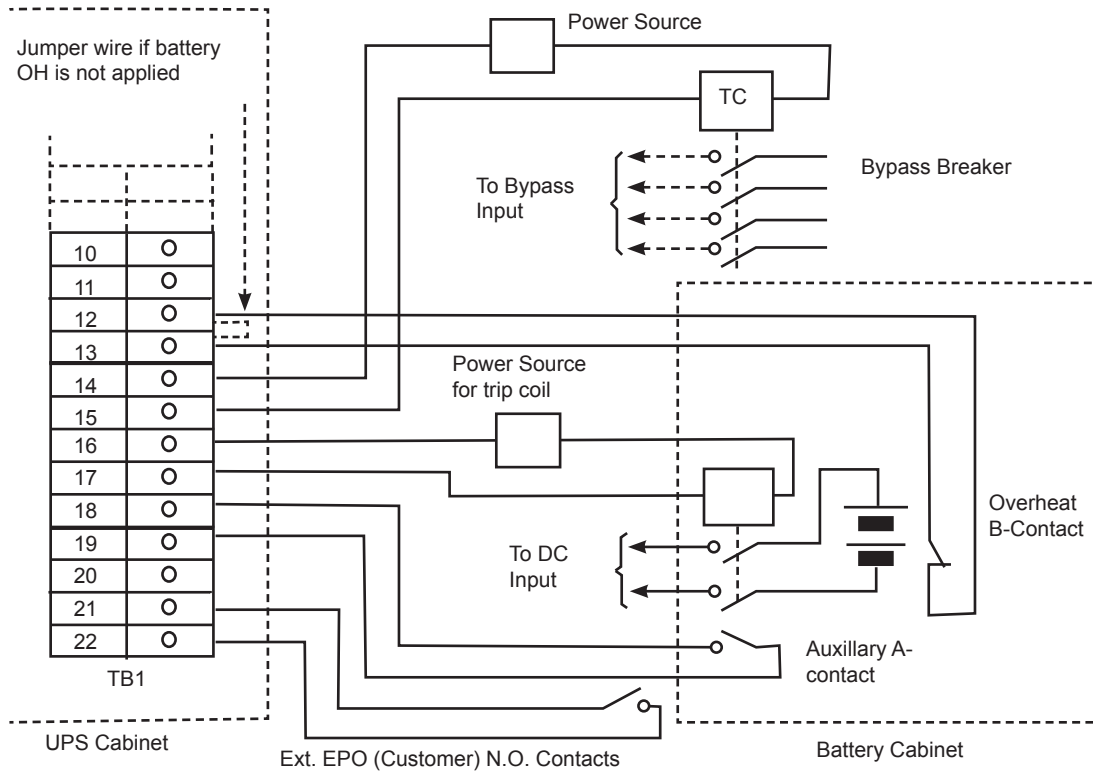

FIGURE 11.15 - CONNECTION BETWEEN UPS, BATTERY CABINET & BYPASS BREAKER

11.7 Grounding Configuration

This section describes the grounding configuration to be used with various AC service entrance configurations. Inadequate grounding will cause problems at start-up. Connections for the ground line and the neutral line must be made appropriately according to the system configuration.

11.7.1 Recommended configuration (for 4 wire input with Input Neutral grounded)

Figure 11.16 shows recommended grounding configuration when the input neutral is grounded.

The neutral line at the input source is usually grounded. The neutral terminal in the UPS cabinet should be disconnected from the ground bus. The neutral connection for the UPS bypass input should be grounded.

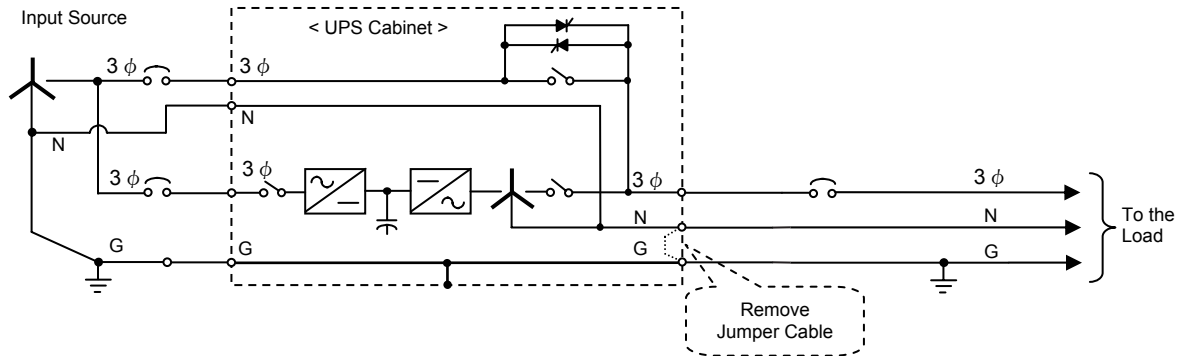

FIGURE 11.16 - GROUNDING CONFIGURATION WITH INPUT NEUTRAL GROUNDED

A 2 AWG (or 38 mm²) jumper cable is provided between the neutral terminal and ground bus in the UPS cabinet. The qualified personnel should remove the jumper cable in this configuration. The jumper cable location is illustrated below.

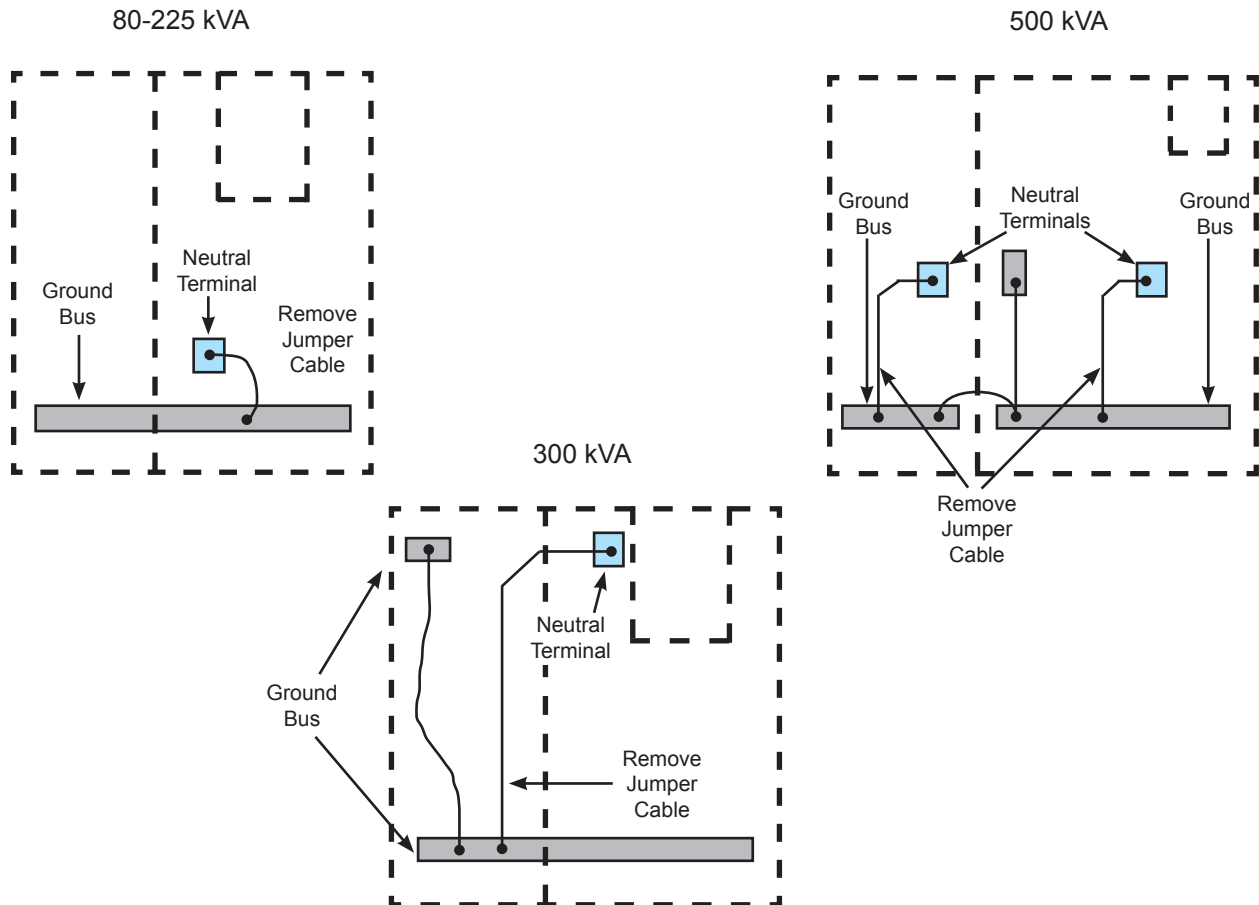

FIGURE 11.17 - JUMPER CABLE BETWEEN THE NEUTRAL TERMINAL & GROUND BUS

11.7.2 Grounding Configuration (without input neutral)

When the input source is wye-connected, the neutral line out to the bypass input should be left open. The UPS is grounded by connecting the neutral terminal to the ground bus with the internal jumper cable. See Figure 11.18.

The jumper cable should stay in place. See Figure 11.17 for the jumper cable location.

If a ground fault interrupter is installed, the UPS is likely to trip the interrupter during transferring to/from the bypass circuit. It is recommended that the ground fault interrupter be set to a minimum delay of 0.5 seconds.

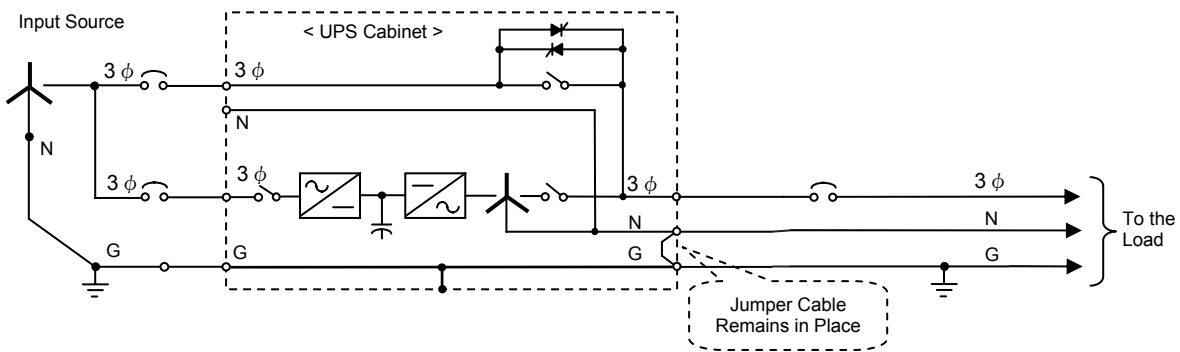

FIGURE 11.18 - GROUNDING CONFIGURATION WITHOUT INPUT NEUTRAL

11.7.3 Recommended Configuration (for delta-input)

If the input source is a delta-connection (3-phase 3-wire) without ground, the neutral terminal in the UPS cabinet must be connected to the ground bus with the internal jumper cable as shown in Figure 11.19.

The jumper cable should stay in place. See Figure 11.17 for the jumper cable location.

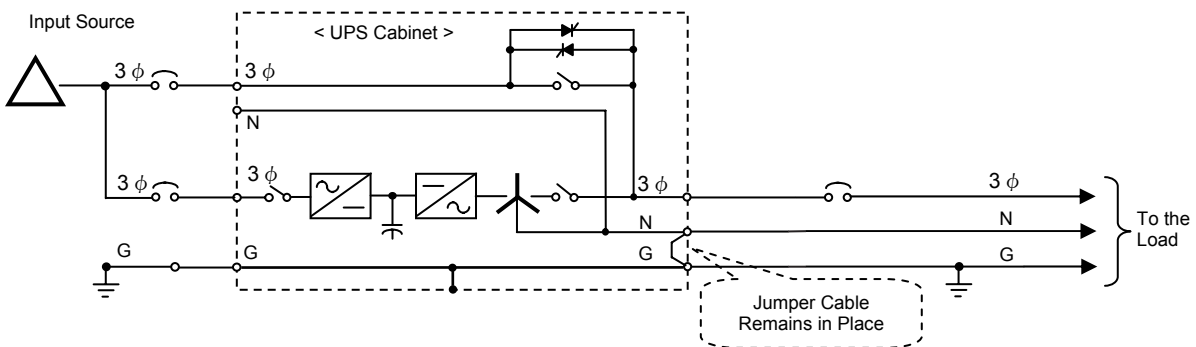

FIGURE 11.19 - GROUNDING CONFIGURATION FOR NON-GROUNDED DELTA-INPUT

11.7.4 Grounding Configuration (with corner-grounded delta-input)

If one phase of delta-input source is grounded (B-phase for example), the ground bus in the UPS cabinet should NOT be connected to the neutral terminal of UPS output.

The jumper cable should be removed see Figure 11.17 for the jumper cable location.

During normal operation the UPS output is floating relative to the ground. An isolation transformer is recommended at output distribution as shown in Figure 11.20.

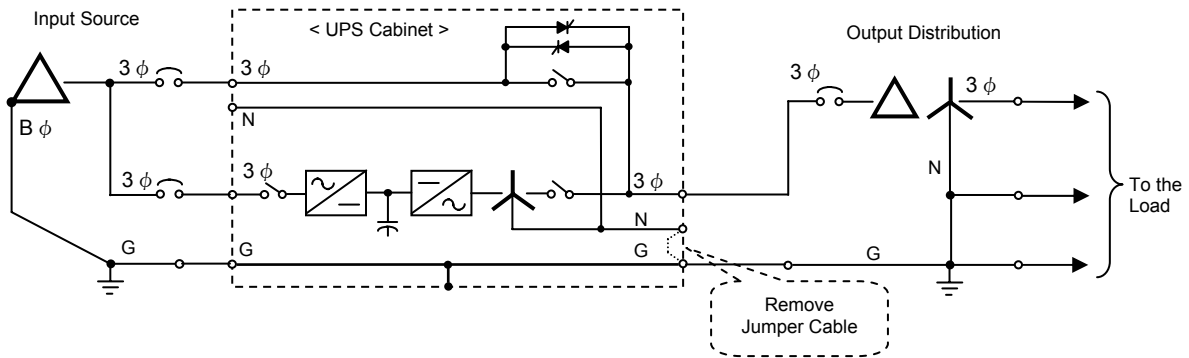

FIGURE 11.20 - GROUNDING CONFIGURATION WITH CORNER-GROUNDED DELTA-INPUT.

12 UPS Specifications

12.1 Specification Table

| G8000 Specifications | | | | | | | | |
|----------------------|--|---|----------------------|----------------------|----------------------|----------------------|----------------------|----------------------|
| Model Number | | T80S3K08 KK6XSxx | T80S3K10 KK6XSxx | T80S3K12 KK6XSxx | T80S3K15 KK6Xxx | T80S3K22 KK6XSxx | T80S3K30 KK6XSxx | T80S3K50 KK6XSxx |
| Input | Rated Output Capacity | 80 kVA / 80 kW | 100 kVA / 100 kW | 125 kVA / 100 kW | 150 kVA / 150 kW | 225 kVA / 225 kW | 300 kVA / 300 kW | 500 kVA / 450 kW |
| | Voltage | 480 VAC (+10% to -15%) | | | | | | |
| | Frequency | 60 Hz (+/-5%) | | | | | | |
| | Configuration | 3 Phase; 3 Wire + GND | | | | | | |
| | Input kVA Normal (Charging) | 89 kVA (100 kVA) | 111 kVA (122 kVA) | 112 kVA (123 kVA) | 163 kVA (174 kVA) | 247 kVA (258 kVA) | 329 kVA (340 kVA) | 484 kVA (505 kVA) |
| | Power Factor | > 0.99 PF Lagging | | | | | | |
| | Walk-in Function | EEPROM Upgrade | | | | | | |
| | Maximum Input Current Normal (Charging) | 107 A (120 A) | 134 A (147 A) | 135 A (148 A) | 196 A (209 A) | 297 A (311 A) | 396 A (409 A) | 582 A (608 A) |
| | Reflected THD | < 5% @ 100% Load < 6% @ 25% Load | | | | | | |
| Bypass | Configuration | 3-Phase; 4-Wire + Gnd | | | | | | |
| | Voltage | 480/277V (±10%) | | | | | | |
| | Frequency | 60 Hz (+/-5%) | | | | | | |
| | Bypass Overload Capacity | 1000% for 1 Cycle, 500% for 2 Cycle | | | | | | |
| Battery | Number of Cells | 180 | | | | | | 240 |
| | Type | Lead Acid (Contact factory for alternative options) | | | | | | |
| | DC Nominal | 360V | | | | | | 480V |
| | DC Minimum | 288V | | | | | | 408V |
| | Float Charge | 405V | | | | | | 540V |
| | Ripple Current (without batteries) | AC Ripple on DC Bus: < 0.2% of DC Voltage | | | | | | |
| | Back-up Time | Application Specific | | | | | | |
| | Max DC Charging Current | 30 A | 30 A | 30 A | 30 A | 30 A | 30 A | 45 A |
| | Max Discharge | 292 A | 359 A | 365 A | 533 A | 805 A | 1073 A | 1193 A |
| | Battery Capacity Required for Full Load Output | 88 kWB | 108 kWB | 110 kWB | 160 kWB | 242 kWB | 323 kWB | 478 kWB |

| G8000 Specifications | | | | | | | | |
|----------------------|-----------------------------|---|--|---|--|--|--|---------------------------------------|
| Model Number | T80S3K08 KK6XSxx | T80S3K10 KK6XSxx | T80S3K12 KK6XSxx | T80S3K15 KK6Xxx | T80S3K22 KK6XSxx | T80S3K30 KK6XSxx | T80S3K50 KK6XSxx | |
| Output | Voltage | 480Y/277V | | | | | | |
| | Configuration | 3-Phase; 4-Wire + Gnd | | | | | | |
| | Voltage Regulation | ±1% for 0-100%Balanced and Unbalanced Loads | | | | | ±2% for 0-100% Balanced and Unbalanced Loads | |
| | Voltage Adjustment Range | ±5% (in increments of 1V) | | | | | | |
| | Voltage Unbalance | ±3% for 100% Linear Loads ±5% for 100% Non-Linear Loads | | | | | | |
| | Crest Factor | 2 | | | | | | |
| | Transient Voltage Response | ±2% Max with a 100% Step Loads (without utilizing batteries) ±1.5% Max with Loss/Return AC input ±2% Max when load transfers To/From Bypass | | | | | | |
| | Transient Recovery Time | <50 ms | | | | | | |
| | Frequency | 60 Hz | | | | | | |
| | Frequency Synchronous Range | ±0.5 Hz, ±1 Hz, + 1.5Hz (Selectable) | | | | | | |
| | Frequency Slew Rate | 1 Hz/Sec | | | | | | |
| | Frequency Regulation | ± 0.01% in free running mode | | | | | | |
| | Current | 96 A | 120 A | 150 A | 180 A | 271 A | 361 A | 601 A |
| | Power Factor | 1.0 PF Lag: 32 - 86 °F (0 - 30 °C) 0.8 PF Lag: 86 - 104 °F (30 - 40 °C) | | 0.8 PF Lag: 32 - 104 °F (0 - 40 °C) | | 1.0 PF Lag: 32 - 86 °F (0 - 30 °C) 0.8 PF Lag: 86 - 104 °F (30 - 40 °C) | | 0.9 PF Lag 32 - 104 °F (0 - 40 °C) |
| | Overload Capacity | 125% for 10 Minutes, 150% for 60 Seconds | | 110% for 5 Minutes, 120% for 60 Seconds | | 125% for 10 Minutes, 150% for 60 Seconds | | |
| | Voltage THD | <3% Max with 100% Linear Load / 5% Max with 100% Non-Linear Load | | | | | | |
| Withstanding Rating | 65 kA (with optional fuse) | | | | | | | |
| Reliability | MTBF | Module only - 200,000 Hrs. / 3,000,000 Hrs. in Bypass | | | | | | |
| Environment | Cooling | Forced Air | | | | | | |
| | Paint Color | Sherwin Williams HHT2-7055, 079 Beige Texture | | | | | | |
| | Weight | 1740 lb. (789 kg) | 1740 lb. (789 kg) | 2467 lb. (1119kg) | 2980 lb. (1352 kg) | 4575 lb. (2075 kg) | 6520 lb. (2957 kg) | |
| | Weight (Shipping) | 1790 lb. (812 kg) | 1790 lb. (812 kg) | 2556 lb. (1159 kg) | 3069 lb. (1392 kg) | 4725 lb. (2143 kg) | -TBD- | |
| | Floor Loading | 210 Lbs/ft ² (1023 kg/m ²) | 210 Lbs/ft ² (1023 kg/m ²) | 203 Lbs/ft ² (990 kg/m ²) | 245 Lbs/ft ² (1196 kg/m ²) | 240 Lbs/ft ² (1173 kg/m ²) | 247 Lbs/ft ² (1204 kg/m ²) | |

| G8000 Specifications | | | | | | | | | |
|--------------------------------|---|---|---------------------|---------------------|----------------------|---------------------|------------------------|------------------------|--|
| Model Number | | T80S3K08 KK6XSxx | T80S3K10 KK6XSxx | T80S3K12 KK6XSxx | T80S3K15 KK6Xxx | T80S3K22 KK6XSxx | T80S3K30 KK6XSxx | T80S3K50 KK6XSxx | |
| Environment (cont.) | Dimension - Width | 36.8 in. (935 mm) | | | 55.1 in. (1400 mm) | | 76.8 in. 1951 mm) | 101.8 in. (2586 mm) | |
| | Depth | 32.5 in. (826 mm) | | | 31.8 in. (808 mm) | | 35.7 in. (907 mm) | 37.4 in. (945 mm) | |
| | Height | 79.2 in. (2012 mm) | | | | | 79.4 in. (2017 mm) | 79.7 in. (2024 mm) | |
| | Cable Access | Bottom Access | | | Top or Bottom Access | | Top Access | | |
| | Minimum Clearance | Top: 15.75" (400 mm) | | | | | | | |
| | | Front: 43 7/16" (1100 mm) | | | | | | 37 in. (940 mm) | |
| | Back/Left/Right Sides: Zero | | | | | | | | |
| | Enclosure | NEMA 1 | | | | | | | |
| | Heat Loss to be Removed @ Full Load | 28,321 BTUs/hr | 33,746 BTUs/hr | 37,281 BTUs/hr | 38,524 BTUs/hr | 67,667 BTUs/hr | 89,011 BTUs/hr | 110,262 BTUs/hr | |
| | Audible Noise | 65 dBA @ 1m Typical | | | 68 dBA @ 1m Typical | | 72 dBA @ 1m Typical | 78 dBA @ 1m Typical | |
| | Operating Temperature | 32°F to 86°F (0°C to 30°C) for 1.0PF 32°F to 104°F (0°C to 40°C) for 0.8 PF | | | | | | | |
| | Operating Humidity | 30% to 90% Non-Condensing | | | | | | | |
| Operating Altitude | 3200 ft. (1000 m) | | | | | | | | |
| Listings/Standards | UL 1778; UL 17025, cUL 22.2, No. 107.1; ANSI C62.41 (IEEE 587 Cat B) NFPA 70; OSHA; ISO 9001; IEC298 IP20 | | | | | | | | |
| Monitoring | Warranty | 3 Years Parts and Labor | | | | | | | |
| | Dry Contacts Included | Yes, for input and output signals | | | | | | | |
| | RS232 Port | Included | | | | | | | |
| | Intelligent Monitoring (Optional) | SNMP; Modbus RTU; Modbus TCP; BACNET, METASYS | | | | | | | |
| | Display | LCD Touch Panel for Local Monitoring, Operation and control | | | | | | | |
| EPO | Emergency Power Off | Included | | | | | | | |
| Configuration | Input Conv. | 6-diode Bridge Rectifier | | | | | | | |
| | Battery Cct | IGBT Chopper | | | | | | | |
| | Out. Inv. | IGBT Converter with PWM | | | | | | | |

12.2 Typical Efficiency vs. Load

| UPS | Efficiency at Percent Full Load* | | | |
|---------|----------------------------------|-------|-------|-------|
| | 25% | 50% | 75% | 100% |
| 80 kVA | 83.9% | 85.3% | 90.0% | 90.6% |
| 100 kVA | 86.4% | 90.1% | 91.2% | 91.0% |
| 125 kVA | 88.5% | 90.9% | 90.9% | 90.2% |
| 150 kVA | 86.9% | 91.7% | 92.3% | 93.3% |
| 225 kVA | 87.9% | 91.9% | 92.3% | 91.9% |
| 300 kVA | 88.8% | 91.6% | 92.2% | 92.8% |
| 500 kVA | 91.6% | 91.1% | 90.2% | 93.3% |

* Actual efficiency may differ due to manufacturing variations and input power quality.

13 Operator Interface

Table 13.1 shows the functions of the operating buttons on the graphic display panel.

NOTICE

Press an operating button for at least 0.5 seconds to change UPS modes. Press the reset button for at least 5 seconds to reset the UPS.

The UPS may not respond if the button press is too short.

TABLE 13.1 BUTTON AND INDICATOR FUNCTIONS (See fig. 13.1 and 13.2)

| # | Name | Function |
|----|---------------------|--|
| 1 | OPERATION LOCK | Enables/disables the buttons RUN, STOP, UPS, BYPASS, FLOAT/EQUAL, and RESET. |
| 2 | STOP BUTTON | Stops the UPS. Transfers to bypass power if available. |
| 3 | RUN BUTTON | Starts the UPS. Transfers the unit from bypass to UPS power. |
| 4 | FLOAT/EQUAL BUTTON | Changes recharge mode between float charge and equalize charge. |
| 5 | SCROLL UP BUTTON | Scrolls the LCD screens up. |
| 6 | SCROLL DOWN BUTTON | Scrolls the LCD screens down. |
| 7 | RESET BUTTON | Reset UPS faults and warnings shown on the LCD. (See Section 13.5) |
| 8 | UPS BUTTON | Transfers from bypass operation to normal operation. |
| 9 | BYPASS BUTTON | Transfers from normal operation to bypass operation. |
| 10 | EPO BUTTON | "ON" during Bypass Supply. |
| 11 | LCD DISPLAY | Displays the operational, status, and warning/fault messages. |
| 12 | UPS SUPPLY LED | "FLASHES" during START or STOP sequence "ON" when operating in inverter mode. |
| 13 | CONVERTER LED | "ON" after DC bus capacitors are fully charged through the converter. |
| 14 | AC INPUT LED | "ON" with nominal AC input. "FLASHES" with AC input under-voltage (85%). |
| 15 | FLOAT CHARGE LED | "ON" during float charge. |
| 16 | EQUALIZE CHARGE LED | "ON" during equalize charge or protection charge while battery OH contact open. |
| 17 | BATTERY LED | "ON" when battery is connected. (aux-contact on) |
| 18 | DISCHARGE LED | "ON" during battery discharge. |
| 19 | BYPASS INPUT LED | "ON" with nominal bypass input. "FLASHES" when bypass is under-voltage (85%). |
| 20 | WARNING LED | Normally "OFF". "ON" when warning displayed on LCD. "FLASHES" when AC input is abnormal. |
| 21 | FAULT LED | Normally "OFF". "ON" when faults occur. |
| 22 | INVERTER LED | Lamp "FLASHES" during START or STOP sequence. "ON" when inverter is operating. |
| 23 | UPS LED | "ON" when the inverter output is connected to the UPS output. |
| 24 | AC OUTPUT LED | "ON" with AC output connected to the bypass/inverter sources. |
| 25 | BYPASS LED | "ON" when the bypass power supplies the load |

13.1 Key-Switch and Buttons

The key-switch and operating buttons on the graphic display panel are shown in Figure 13.1. See the sections titled “Key-switch” and “Operating buttons” for each function.

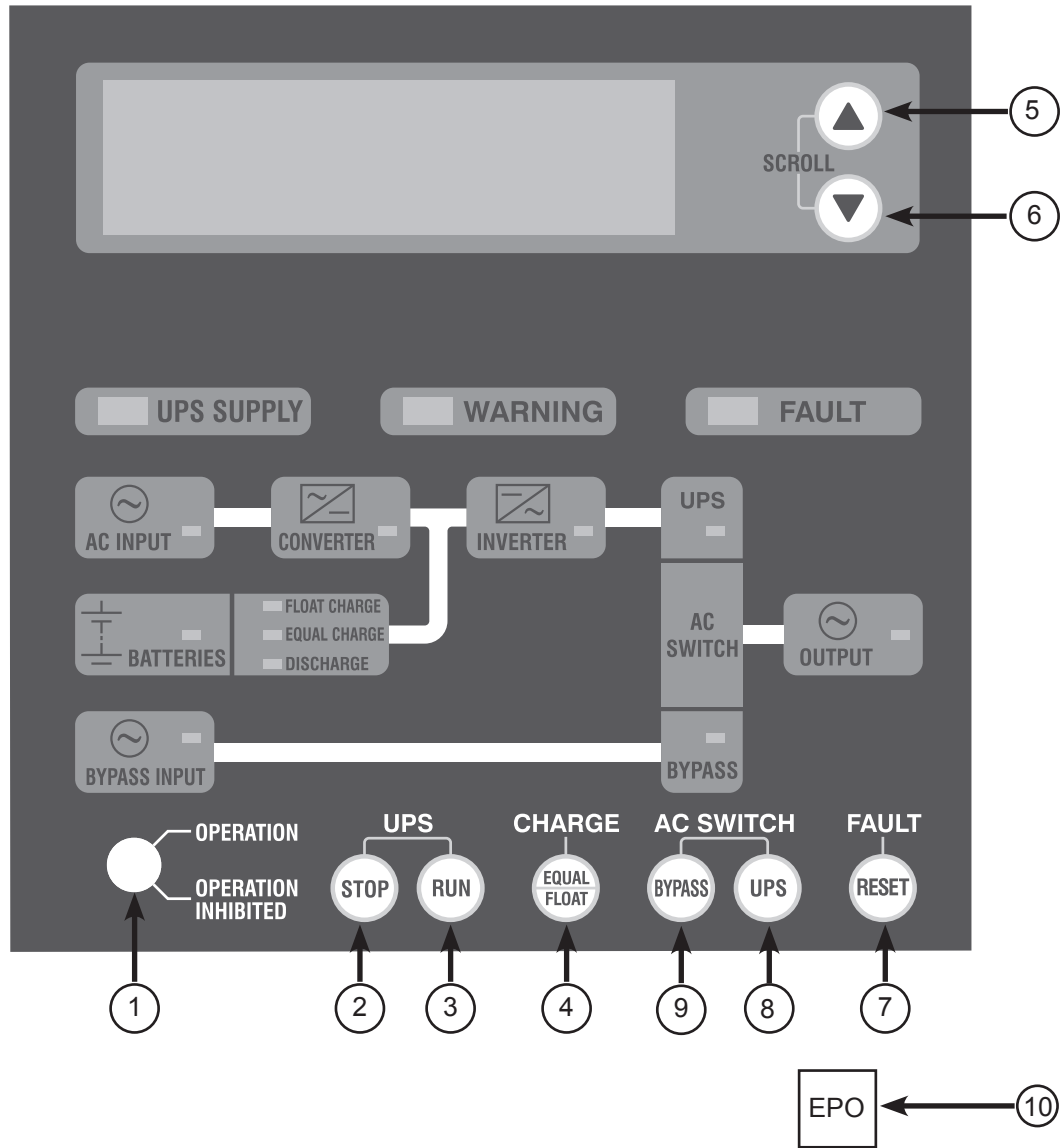

FIGURE 13.1 – GRAPHIC DISPLAY PANEL KEY-SWITCH/OPERATING BUTTONS

13.2 LCD/LED Indicators

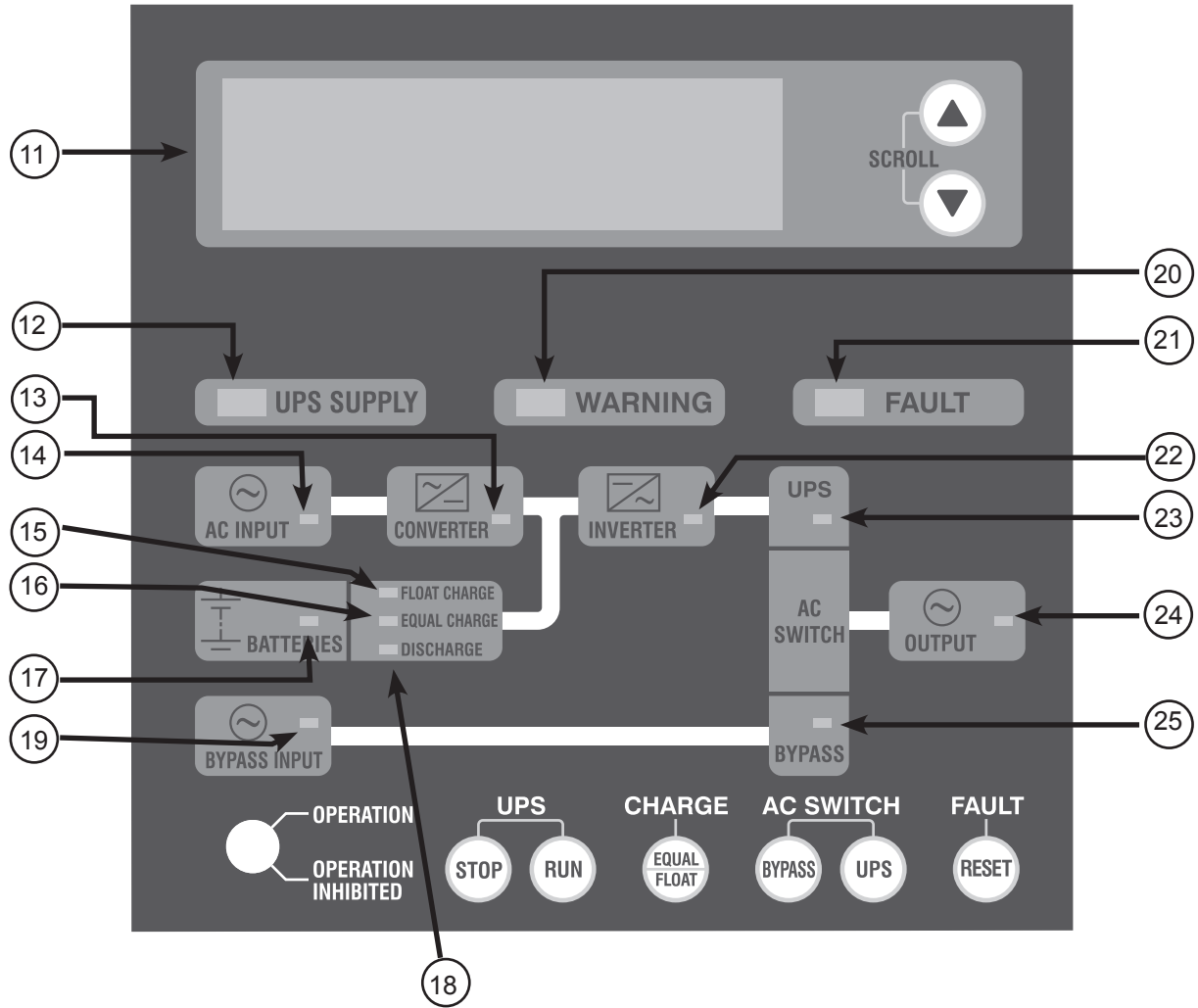

FIGURE 13.2 – GRAPHIC DISPLAY PANEL LCD/LED INDICATORS

13.3 LCD Indicators

The operator can scroll through the following LCD display screens using the scroll buttons.

TABLE 13.2 - LCD DISPLAY SCREENS

| Name | Description |
|-----------------|---|
| Normal Display | Displays operational status, operational guidance, and measured data. |
| Fault Display | Displays detailed data when a fault occurs. |
| Warning Display | Displays detailed data when a warning occurs. |

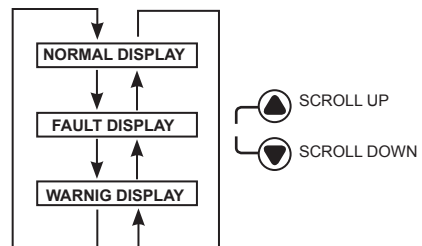

FIGURE 13.3 - CHANGING SCREENS WITH SCROLL BUTTONS

13.4 Normal Display

The Normal Display screen indicates the UPS operational status and provides various screens: an operation guidance screens, mode screens and measured data screens. Table 13.3 shows these screens page by page and illustrates the UPS Normal Display operational status screens.

TABLE 13.3 - NORMAL DISPLAY SCREEN EXAMPLES

OPERATIONAL STATUS SCREENS

| |
|--------------------|
| BYPASS |
| PRESS 'RUN' SWITCH |

Shows the UPS status at the top and guidance message or measured data underneath.

Shows a guidance message at start up.

| |
|-----------------------------|
| UPS SUPPLY |
| AC-VO 480[V] AC-IO 50[%] |

Shows the output voltage and current after start up.

| |
|--------------------------------|
| OPERATION MODE |
| NORMAL OPERATION MODE SYNC. |

Shows the UPS Operation mode.

MEASUREMENT SCREENS

| |
|--------------------------------|
| O/P VOLTAGE |
| VOLT. 480[V] FREQ. 60.0[Hz] |

Output Voltage: Shows the output line-to-line output voltage.

| |
|-------------------------------|
| O/P CURRENT (R.M.S.) |
| U 50[%] V 50[%] W 50[%] |

Output Current: Shows the RMS output current (%) for each phase..

TABLE 13.3 - CONTINUED

MEASUREMENT SCREENS

| O/P CURRENT (PEAK) | |
|---------------------------|-------|
| U | 50[%] |
| V | 50[%] |
| W | 50[%] |

Shows the peak output current peak (%) for each phase.

$$\frac{\text{Peak value of output current}}{\text{RMS value for rated current} \times 1.41} \times 100 [\%]$$

| AC INPUT | |
|-----------------|----------|
| AC I/P-V | 480[V] |
| FREQ. | 60.0[Hz] |

Shows the AC Input Voltage (line-to-line) and frequency.

| BYPASS INPUT | |
|---------------------|----------|
| BYP I/P-V | 480[V] |
| FREQ. | 60.0[Hz] |

Shows the Bypass Input Voltage (line-to-line voltage) and frequency.

| DC INPUT | |
|-----------------|--------|
| DC-V | 632[V] |
| BATT-V | 400[V] |
| BATT-I | 0[A] |

Shows the internal DC bus voltage, battery voltage and battery current.

The battery current value displayed is negative during recharge and positive during discharge.

| MODE COUNT | |
|-------------------|---------|
| UPS | 35[H] |
| BATTERY | 56[MIN] |
| | 32[TIM] |

Shows the cumulative UPS operation time, the cumulative battery backup time and the number of battery backup operations.

| CLOCK | |
|--------------|----------------|
| TIME | 03-24-06 13:58 |

The current time is displayed if there are no faults recorded, or after the reset button is pressed.

Date is displayed in the mm-ddyyy format. The unit does not calculate daylight savings time.

Time is displayed in the 24-hour format (e.g. 1:58 P.M. = 1358 Hrs.)

13.5 Fault Display

The Fault Display screen displays the fault records until they are reset. The Warning Display screen displays the warning records until they are reset. The fault records will remain in the memory until the reset button is pressed for at least 5 seconds, even after the actual cause of the fault has been resolved. Note that the fault records are not deleted when the UPS is turned off.

If the UPS is RESET while the system is in normal or bypass mode, the fault history is cleared and operation continues.

If the UPS is RESET while the system is on backup mode, the system will power down, re-initialize, and restart.

TABLE 13.4 FAULT & WARNING DISPLAY SCREEN EXAMPLES

| FAULTS & WARNINGS |
|--|
| 1 FUSE BLOWN 09-09-06 08:05:30 ↓ ANOTHER ITEM |

A fault record is shown with time stamp.
 An arrow indicates that another record can be displayed by pressing the up/down buttons.

| FAULTS & WARNINGS |
|--|
| 1 UPS OVERLOAD 09-09-06 08:05:30 ↓ ANOTHER ITEM |

A warning record is shown with time stamp.
 An arrow indicates that another record can be displayed by pressing the up/down buttons.

| FAULTS & WARNINGS |
|--------------------------------------|
| NO ALARM NO WARNING |

This screen is displayed if there are no warnings recorded, or after the reset button is pressed.

13.6 LCD Scroll

Scroll through the LCD display screens (see Figure 13.5), in sequence, using the “SCROLL UP” and “SCROLL DOWN” buttons on the graphic display panel.

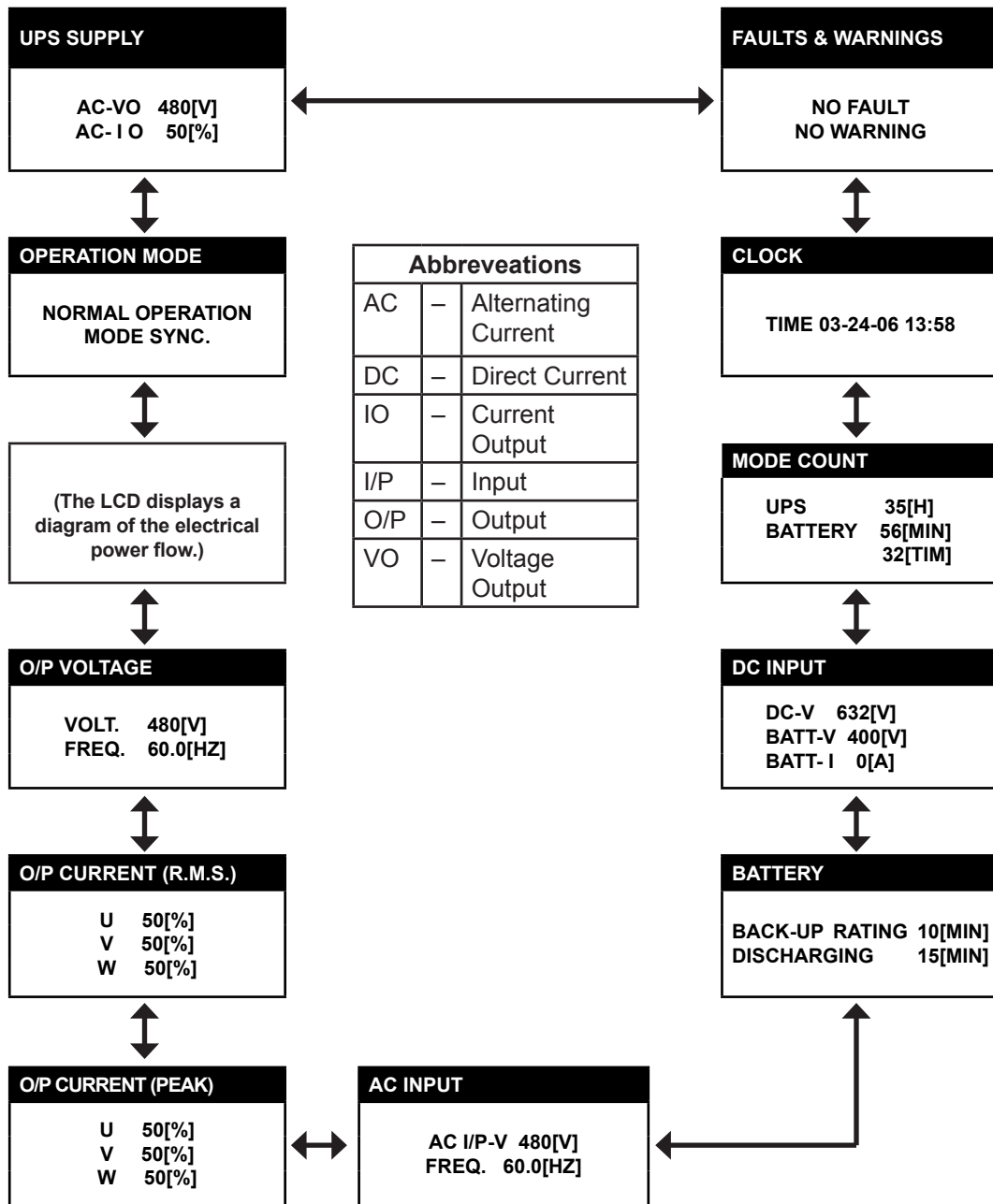

- **SCROLL UP** - Moves back to the previous screen
- **SCROLL DOWN** - Moves forward to the next screen

TABLE 13.5 DISPLAY SCREEN SCROLL SEQUENCE



14 Operating the UPS

This section describes the basic procedures to operate the UPS. Figure 14.1 shows the location and functions of the operating switches to operate the UPS.

|  WARNING | |
|--|---|
|  | <p>If the UPS produces smoke or smells strange, immediately turn off all AC and DC input circuit breakers.</p> <p>Continued operation may result in fire. Contact Toshiba or Authorized representatives.</p> |
|  | <p>DO NOT turn off the control power supply switch (8A) during UPS operation.</p> <p>This may result in UPS faults.</p> |

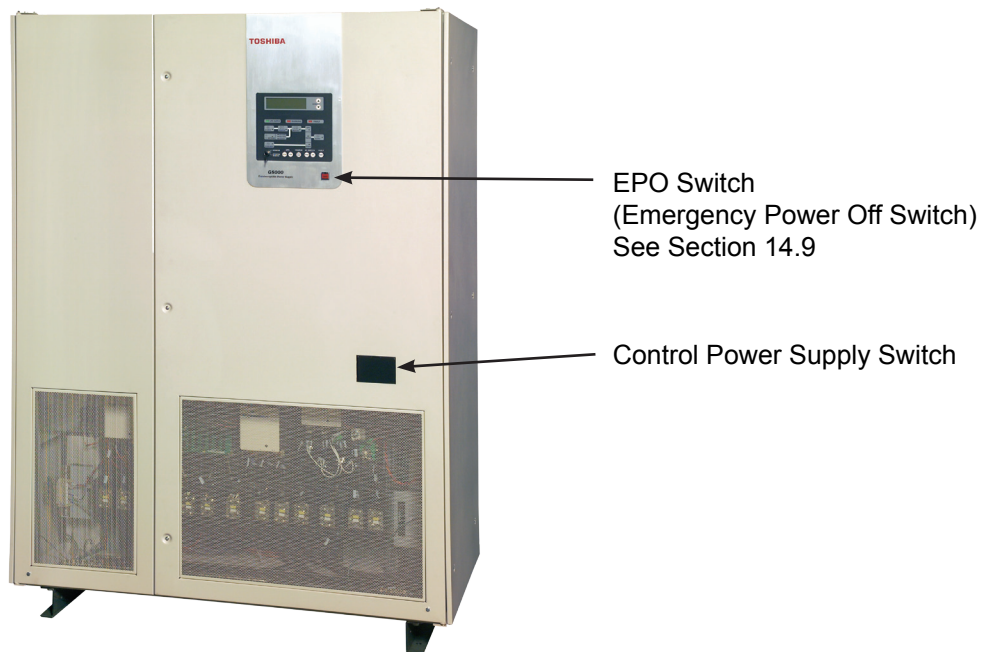

FIGURE 14.1 - EPO AND CONTROL POWER SUPPLY OPERATING SWITCHES



14.1 Operation Types

The operation types are summarized below.

TABLE 14.1 OPERATION TYPES

| Operation | Description |
|-------------------------|--|
| Complete Shutdown | Turn off the control power supply. Shut down the UPS completely. |
| Float / Equalize Charge | Changing the battery recharge mode between float charge and equalize charge. |
| Protection Charge | Automatic recharge mode transition from protection charge to float charge. |
| Startup | Starting up and operating the UPS. |
| Stop | Stop the inverter and chopper/charger. |
| Switch Power Supply | Switching power supply source between UPS and Bypass. |

14.2 Pre-operational Check

| | |
|--|--|
|  CAUTION | |
|  | Perform the pre-operational check before operating the UPS. |

Before operating the UPS:

1. Make sure all covers/panels are in place and secured.
2. Make sure the temperature in the UPS/Battery room is within specified limits.
3. Before starting the UPS, check the power source to make sure AC input power is on.
4. Make sure battery breaker's auxiliary A-contact is connected to the terminal block TB1.

14.3 Startup Procedures

The procedure to start the UPS is shown in Steps 1-5.

LED Key
 □ - LED Off
 ■ - LED On
 ✦ - LED Flash

STEP 1

Turn on the control power supply switch. (Figure 14.1) and ensure the operation lock is set to OPERATION. (Figure 13.1 - 1)

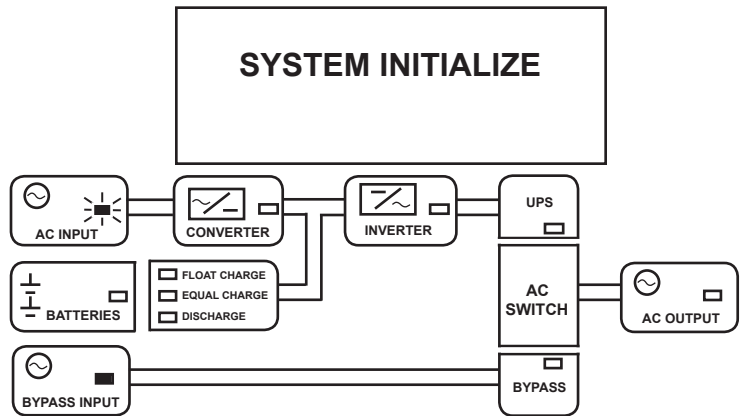

STEP 2

Wait for a few seconds.

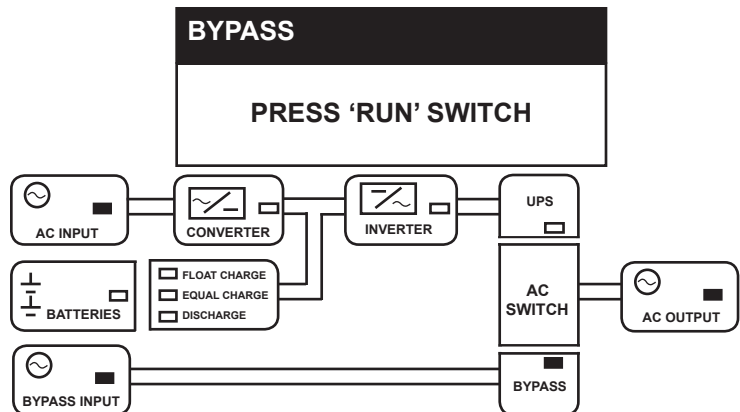

STEP 3

Press the "RUN" button for at least 0.5 seconds.

CONVERTER LED is "ON" and INVERTER LED flashes.

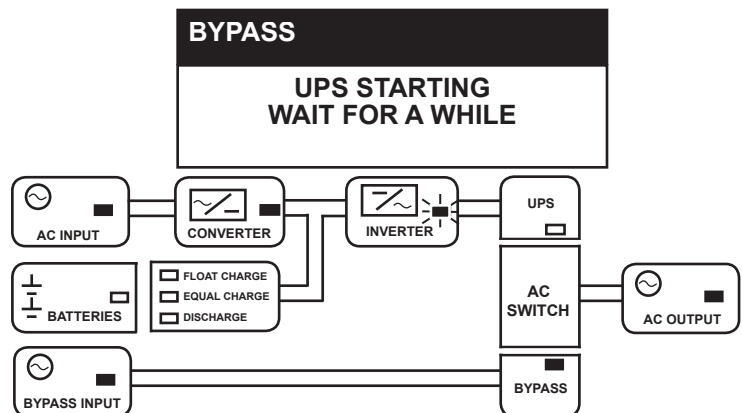

Step 4-5 continues the procedure to start the UPS.

LED Key
 - LED Off
 - LED On
 - LED Flash

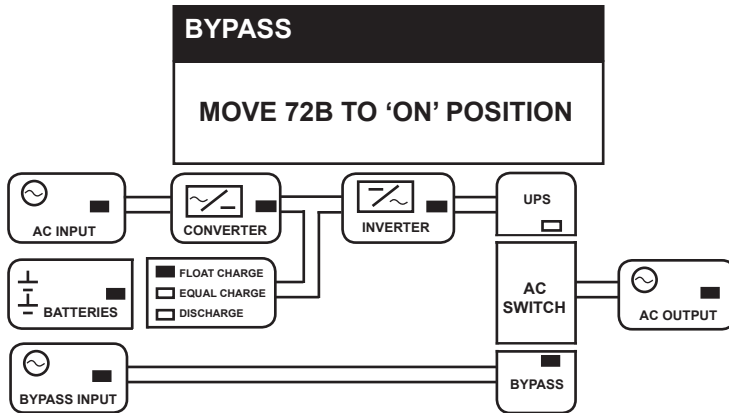

STEP 4

Turn on the DC Input Breaker (72B) on the external battery cabinet.

BATTERIES LED is “ON”.

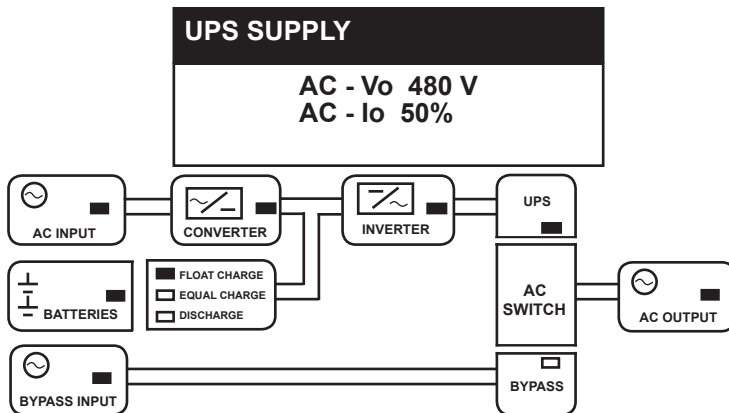

STEP 5

*Press the “UPS” button for at least 0.5 seconds. This completes UPS startup procedure

BYPASS LED is “OFF”.

UPS LED is “ON”.

NOTE

*If the AC switch does not function, contact Toshiba or authorized representatives.

If the bypass power source is out of specification, this operation will be inhibited. In order to switch manually, press the “UPS” button for 5 seconds or more.

14.4 Switch Power Supply (UPS to Bypass)

The procedure to transfer between the UPS supply and the bypass supply is shown in Steps 1-3

LED Key
 - LED Off
 - LED On
 - LED Flash

STEP 1

Check AC INPUT LED and BYPASS LED are on to make sure power is being delivered to the UPS.

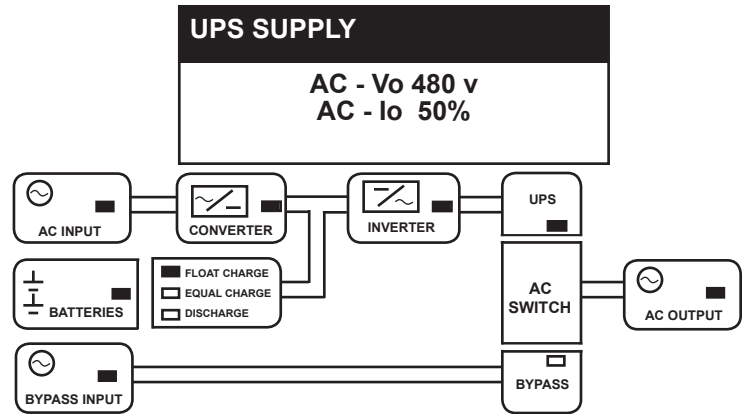

STEP 2

Press the "BYPASS" button for at least 0.5 seconds.

UPS LED is "OFF".

BYPASS LED is "ON".

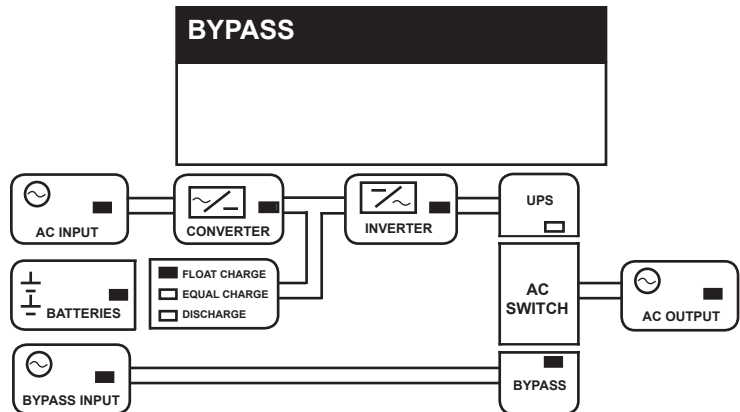

STEP 3

Please wait until procedure is completed.

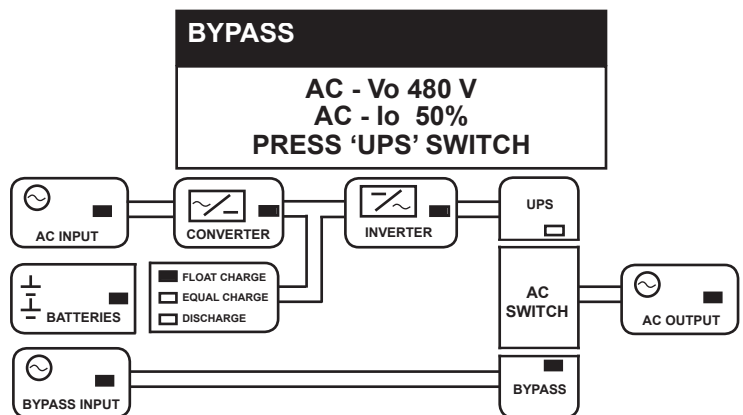

NOTE

To change from Bypass to UPS supply, follow the **Startup Procedures - STEP 5**.

If the AC switch does not function, contact Toshiba or authorized representatives.

14.5 Stop

The procedure to stop the UPS is shown in Steps 1-3.

LED Key
 - LED Off
 - LED On
 - LED Flash

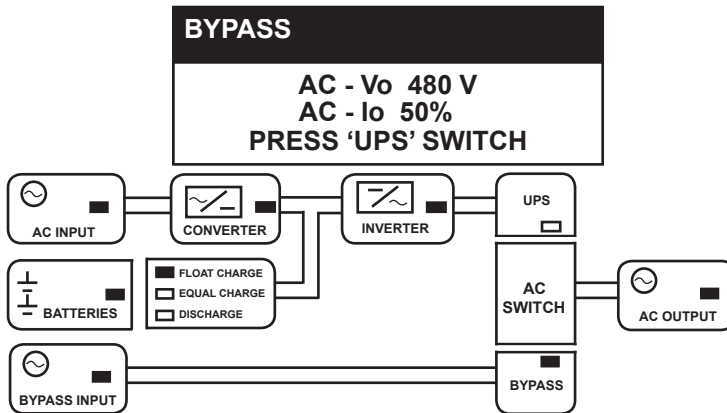

STEP 1

Transfer to Bypass supply as described in **Switch Power Supply**.

UPS LED is "OFF".

BYPASS LED is "ON".

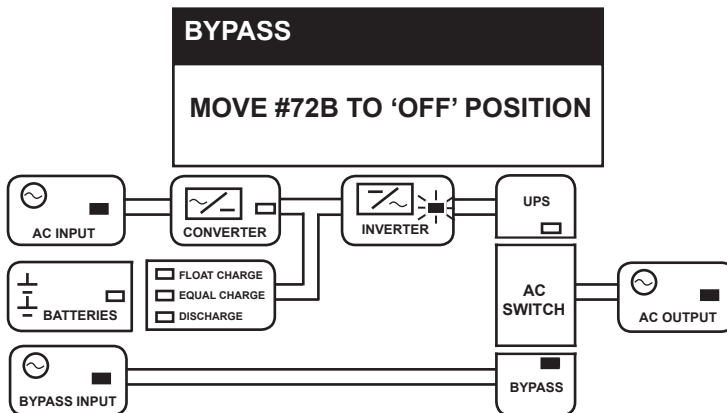

STEP 2

Turn off the DC Input Breaker (72B) on the external battery cabinet, and, press the G8000 "STOP" button for at least 0.5 seconds.

BATTERIES LED is "OFF".

INVERTER LED flashes then "OFF".

FLOAT CHARGE LED and CONVERTER LED are "OFF".

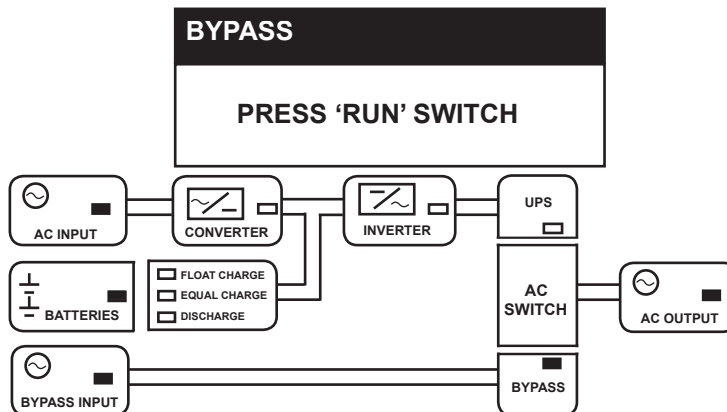

STEP 3

Wait until procedure is completed.

14.6 Complete Shutdown

The procedure to turn off the control power and shut down the UPS completely is shown in Steps 1-6.

STEP 1

Transfer to Bypass supply as described in **Switch Power Supply**.

UPS LED is "OFF".

BYPASS LED is "ON".

| BYPASS | |
|--------|-------|
| DC-V | 0 [V] |
| BATT-V | 0 [V] |
| BATT-I | 0 [A] |

STEP 2

Turn off the DC input breaker, and, press the "STOP" button for at least 0.5 sec.

BATTERIES LED is "OFF".

INVERTER LED flashes then "OFF".

FLOAT CHARGE LED and CONVERTER LED are "OFF".

STEP 3

Please wait until procedure is completed.

STEP 4

Scroll the LCD screen to see the DC INPUT and make sure DC bus voltage is 0V.

STEP 5

*Turn off the control power supply switch (8A).

Nothing is displayed on the LCD.

All LED's are "OFF".

STEP 6

Turn off all breakers at AC Input, Bypass Input, and AC Output.

Shutdown is completed and UPS is isolated.



NOTICE

**STEP 5 - This operation is different from the instructions displayed on the screen.*

Be sure to perform the procedure as specified in this manual.

14.7 Changing Between Float Charge and Equalize Charge

The procedure to change the recharge mode between float charge and equalize charge is shown in Steps 1-3.

See the Note below for an explanation of Float and Equalize charge modes.

LED Key
 - LED Off
 - LED On
 - LED Flash

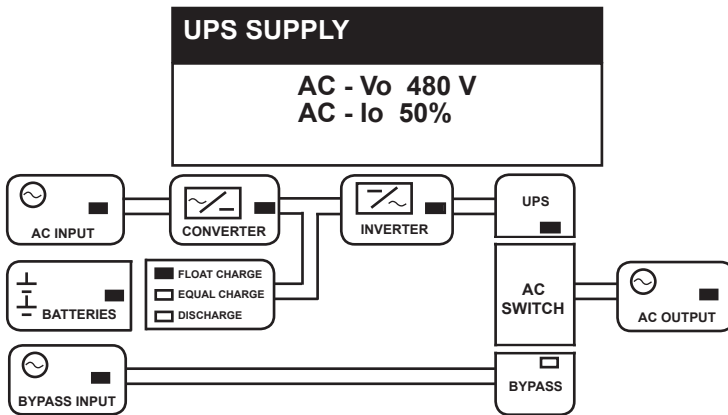

STEP 1

Make sure that the FLOAT CHARGE LED is "ON".

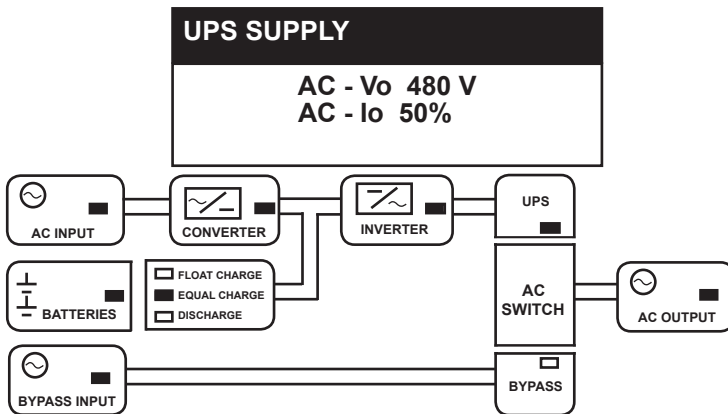

STEP 2

Press FLOAT/EQUAL button for at least 0.5 sec.

Change completed.

EQUAL CHARGE LED is "ON".

FLOAT CHARGE LED is "OFF"

STEP 3

Please wait until procedure is completed.

NOTE

In equalize charge mode, the battery is charged for a programmed period at a specified voltage (depending on the battery spec), rather than the float charge, in order to prevent voltage deviations among battery cells. This should be done once every six months if possible.

The G8000 UPS will automatically perform the equalize recharge after battery backup operation.

14.8 Changing to Float Charge from Protection Charge (If applicable)

The manual procedure to change from protection charge to float charge is shown in Step 1-3. This operation applies to batteries after they have experienced over temperature condition.

See the Note below for an explanation of float charge and protection charge.

LED Key
 - LED Off
 - LED On
 - LED Flash

STEP 1

Make sure that the EQUAL CHARGE LED is "ON".

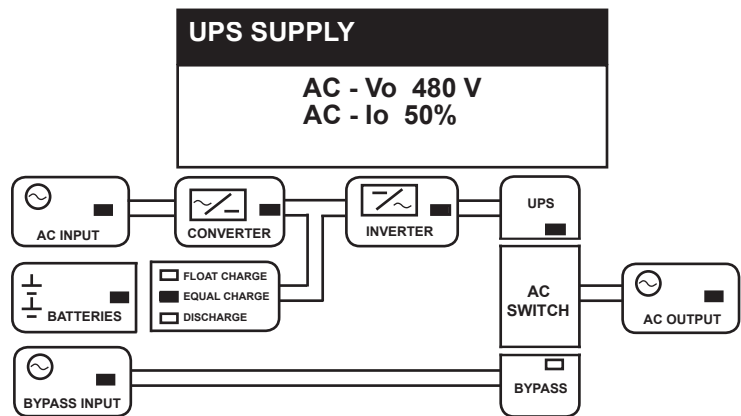

STEP 2

Make sure that the "BATT FAULT1" warning goes away.

STEP 3

Press "FLOAT/EQUAL" button for at least 0.5 seconds.

Procedure completed.

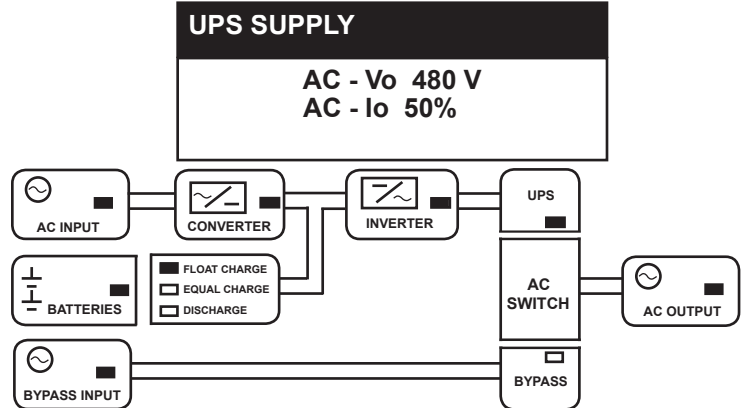

NOTE

The battery is normally being charged at float charge mode. To prevent thermal runaway of the battery, this mode will automatically be changed to protection charge when a "BATT FAULT1" (Battery over temperature) warning occurs.

In protection charge mode, the battery is automatically charged at a voltage about 5% lower than float charge.

If the "BATT FAULT1" warning message goes away and a programmed duration is elapsed (about 24 hours), this mode will automatically be changed back to float charge. Thus, it is not usually required to change the recharge mode manually back to the float charge.

14.9 Emergency Power Off (EPO)

Press the EPO switch for immediate shutdown of all power through the UPS. The signal from the EPO is processed as a “hard fault” by the UPS and results in gate-blocks on the transistors and opens all the internal contactors.

To Reset the UPS after triggering the EPO, do the following:

1. Shut Down the UPS as described in section 14.6.
2. Restart the UPS as described in section 14.3.

15 Troubleshooting

When an error occurs in the UPS, error data is displayed on the LCD screen. This section will describe the types of errors, the error messages displayed on the LCD screen and the procedures to correct the errors.

15.1 Types of Errors

The following types of errors may occur in the UPS:

TABLE 15.1 OPERATION TYPES

| Name | | Description |
|---------|---------------------------------|--|
| Fault | Fault (Trip) | The UPS has been tripped and has stopped operating. The UPS is in Bypass mode. |
| Warning | Warning-1 (Input Power Failure) | Power is supplied from the battery. When the warning is corrected, power will automatically be supplied from the AC input. |
| | Warning-2 (Stop and Restart) | The UPS transfers to Bypass supply and the UPS stops operating. When the warning is corrected, the UPS will automatically be restarted and revert to UPS supply. |
| | Warning (Operation Control) | An error or a phenomena related to an error occurred. Since this problem does not directly affect operation, the system switches to synchronized mode. |
| | (Guidance) | An error or indication of an error has occurred, but operation was not affected. |

15.2 Faults and Warnings Data Screen

This screen appears when a trip error is detected. Up to 10 screens of fault data can be displayed. Figure 15.1 and Table 15.2 show a sample screen and describe the data shown in the screen.

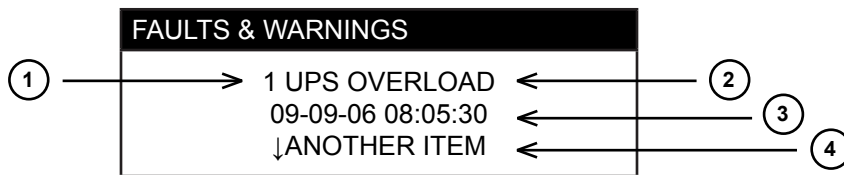

FIGURE 15.1 - SAMPLE FAULT DATA SCREEN

TABLE 15.2 - FAULT AND WARNING DATA SCREEN DESCRIPTIONS

| # | Name | Description |
|---|------------------|--|
| 1 | Number | The number of the message in the order that it was detected (1 - 10). (Up to 10 screens of fault data can be displayed.) |
| 2 | Message | Shows the type of the fault or warning message. |
| 3 | Time | The date (mm-dd-yy) and time (in 24-hour format) the fault was detected. |
| 4 | Scroll Indicator | Indicates whether there is a fault screen before or after this screen. |
| | | Indicates there is a fault screen before this screen. |
| | | ↓ Indicates there is a fault screen after this screen. |
| | | ↓ Indicates there are fault screens before and after this screen. |

15.3 LCD Fault & Warning Displays

When a fault occurs, a screen is shown as in Figure 15.2. When a warning occurs, a screen is shown as in Figure 15.3. Select the desired fault or warning data to be displayed using the scroll buttons.

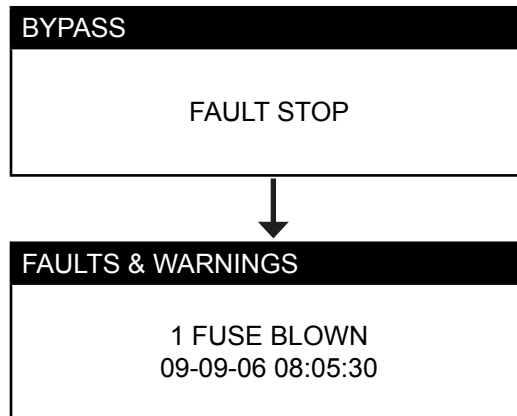

FIGURE 15.2 - FAULT DISPLAY

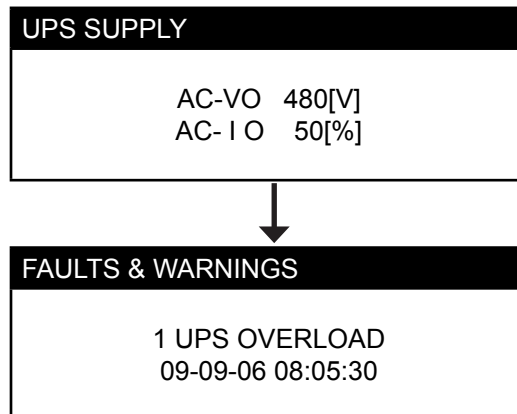

FIGURE 15.3 - WARNING DISPLAY

15.4 Fault Messages

Figure 15.4 show the locations for fault detection. Tables 15.3 through 15.7 gives details for the fault and warning messages referred to in section “Fault Data Screen.” The “item” code associated with each fault or warning message may be used to determine the physical location of the fault or warning by referring to Figure 15.4. The UPS unit may be shipped with different protective configurations from the standard shown in Figure 15.4, if specified by the customer. See the protective configuration indicated on the single line diagram for each UPS.

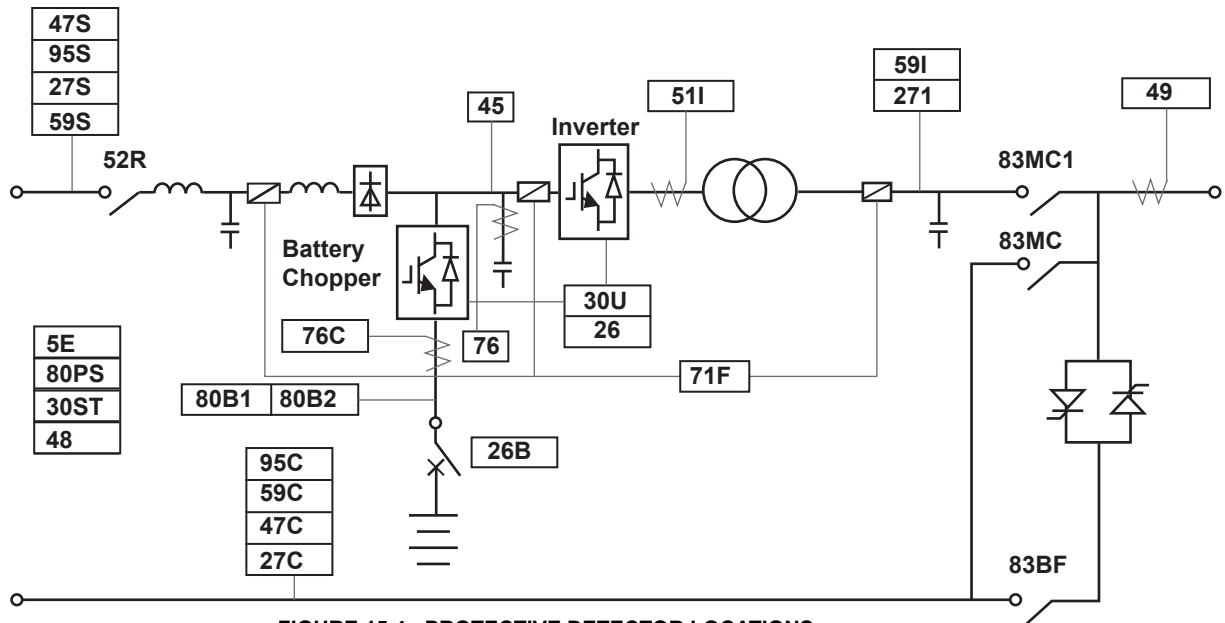

FIGURE 15.4 - PROTECTIVE DETECTOR LOCATIONS

TABLE 15.3 - FAULT (TRIP)

| ITEM | LCD MESSAGE INDICATION | DESCRIPTION |
|------|------------------------|---|
| 26 | OVER HEAT | HIGH TEMP IN THE CABINET. |
| 30ST | (NO INDICATION) | AN ERROR OCCURRED IN THE MAIN CONTROL MICROPROCESSOR (CPU). |
| 48 | STARTUP ERR | STARTUP WAS NOT COMPLETED WITHIN THE NORMAL TIME FRAME. |
| 5E | EMG.STOP | AN EMERGENCY STOP WAS ACTIVATED VIA THE EXTERNAL CONTACT. |
| 71F | FUSE BLOWN | RECTIFIER, DC, OR INVERTER MAIN CIRCUIT FUSE BLOWN. |
| 76 | DC OC | DC OVER-CURRENT - EXCESSIVE CURRENT IN DC CIRCUIT. |
| 80B2 | BATT. UV | BATTERY VOLTAGE IS BELOW CUTOFF VOLTAGE. |
| 80PS | CONT. PS. ERR | THE CONTROL POWER SUPPLY VOLTAGE FAILED. |

TABLE 15.4 - WARNING – 1 (CONVERTER STOP/INPUT POWER ERROR)

| ITEM | LCD MESSAGE INDICATION | DESCRIPTION |
|------|------------------------|--|
| 27S | AC I/P UV | AC INPUT UNDERVOLTAGE - AC INPUT VOLTAGE IS TOO LOW. |
| 47S | AC PHASE ERR | AC INPUT PHASE ROTATION ERROR. |
| 59S | AC I/P OV | AC INPUT OVERVOLTAGE - AC INPUT VOLTAGE IS TOO HIGH. |
| 95S | I/P FREQ. ERR | AC INPUT FREQUENCY ERROR. |

TABLE 15.5 - WARNING - 2 (STOP AND RESTART)

| Item | LCD Message Indication | Description |
|------|------------------------|----------------------------------|
| 27I | AC O/P UV | AC output voltage is low. |
| 30U | UNIT FAULT | IGBT Stack Failure. |
| 45 | DC OV | Over-voltage in DC circuit. |
| 49 | AC O/P OL | Output overload |
| 51I | INV. OC | Inverter over-current. |
| 59I | AC O/P OV | AC output voltage is high. |
| 76C | BATT. OC | Over-current in Battery section. |

TABLE 15.6 - WARNING (OPERATION CONTROL)

| Item | LCD Message Indication | Description |
|------|------------------------|------------------------------------|
| 27C | BYPASS UV | Bypass input voltage is low. |
| 47C | BYPASS ERR. | Bypass input phase rotation error. |
| 59C | BYPASS OV | Bypass input voltage is high. |
| 95C | BYPASS ASY. | Bypass input frequency error. |

TABLE 15.7 - WARNING (GUIDANCE)

| Item | LCD Message Indication | Description |
|------|------------------------|---|
| 26B | BATT. OVER HEAT | Battery temperature is too high. |
| 80B1 | BATT. UV (ALM) | Battery voltage is near cutoff voltage. |

15.5 LCD Scroll (w/ faults or warnings)

This section describes how to scroll through the LCD screens when a fault has occurred (when Fault Data screens exist).

Figure 15.5 shows the locations of the buttons to scroll the LCD screens. See Table 15.8 for details of the scroll buttons and how they are used for screen scrolling.

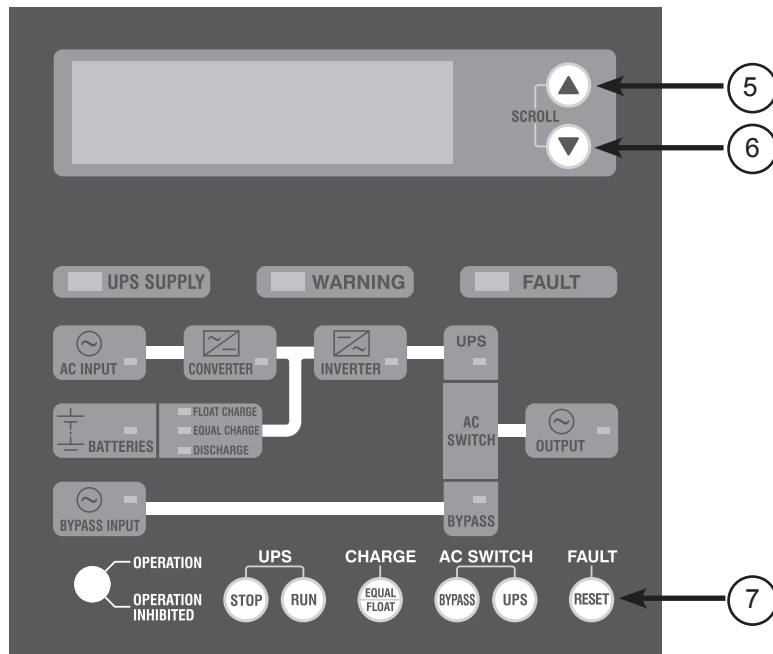





FIGURE 15.5 - POSITION OF SCROLL AND RESET BUTTONS

TABLE 15.8 - BUTTON FUNCTIONS

| # | Name | Function |
|---|-------------|--|
| 5 | SCROLL UP | Scrolls to the previous screen. |
| 6 | SCROLL DOWN | Scrolls to the following screen. |
| 7 | RESET | Resets the UPS faults and warnings shown on the LCD and deletes fault history data stored in memory. |

15.6 Restoring UPS Operation

|  WARNING | |
|--|--|
|  | <p>Contact Toshiba in the event of malfunction or fault.</p> <p>This UPS should be repaired only by factory authorized personnel. Servicing by untrained personnel may extend the fault or result in electric shock or personal injury.</p> |
|  | <p>Do NOT attempt to modify or relocate the UPS.</p> <p>Electric shock, personal injury or fault may result if unauthorized personnel attempt to modify or relocate the UPS. Be sure to contact toshiba customer service if you need to modify or relocate the UPS.</p> |
|  | <p>Do not open the front and/or rear panels.</p> <p>The parts inside carry energy-high current. Touching them may result in electric shock, burns or fault.</p> |

The procedure to restore UPS operation is shown in Steps 1-2. The example shows the UPS restored after a trip fault occurred on inverter over current with the message “INV. OC.”

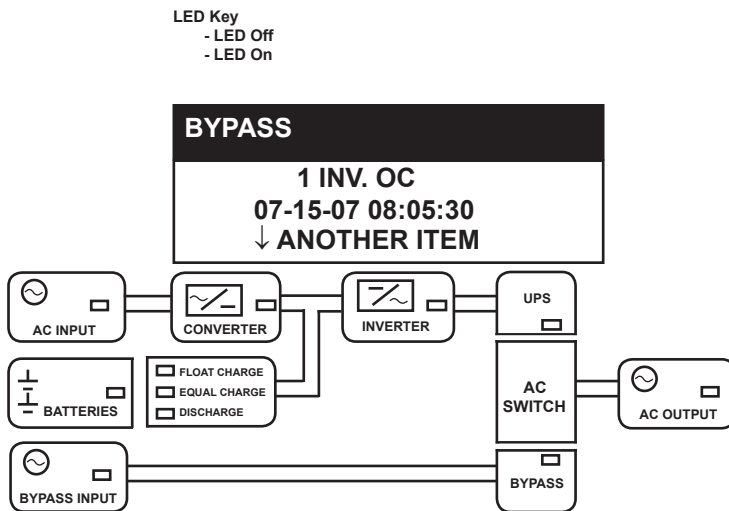

STEP 1

Check the LCD screen.

Also check other fault data screens with scroll buttons graphic panel.

STEP 2

Contact Toshiba Customer Support and follow the directions given by the service personnel.

16 Periodic Maintenance/Parts Replacement

The G8000 is designed to provide long-term trouble-free power conditioning and backup. Optimum performance can be best maintained by regular, periodic, preventive maintenance.

16.1 Scheduled Maintenance

The G8000 UPS should have scheduled maintenance performed on it annually by a factory-authorized service provider. The preventive maintenance should include at minimum:

- Clean UPS exterior
- Clean UPS interior
- Verify power supply voltages
- Check for loose/overheated connections
- Scan error log and correct potential UPS-related issues

16.2 Parts Replacement

The following list shows the recommended intervals for periodic replacement of certain UPS parts.

- Aluminum electrolytic capacitors: Replace once every 7-10 years.
- Fuses: Replace once every 7-10 years
- Cooling fan: Replace once every 7-10 years
- Batteries (If applicable): See the Backup Battery Cabinet manual for specific test, maintenance and replacement instructions.

Appendix A - Installation Planning Guides

TOSHIBA G8000 Series UPS

Installation Planning Guide for 80kVA UPS

Standard System: 480V Input, 480Y/277V Output (P/N T80S3K08KK6XSxx)

| General Mechanical Information | | | | | | | | |
|--------------------------------|--------|-----------------------|--------------------------------------|---|-------|--------|-------|------|
| Dimensions (W x D x H) | Weight | Floor Loading | Approximate Full-Load Heat Rejection | Mechanical Clearance (Inches) from UPS for Ventilation and Maintenance Access | | | | |
| Inches | Lbs. | Lbs./ft. ² | Btu/Hr | Top | Front | Bottom | Sides | Back |
| 36.8" x 32.5" x 79.2" | 1,740 | 210 | 28,321 | 15.75" | 43.5" | 0" | 0" | 0" |

| Primary AC Input (480V 3-Phase / 3-Wire) | | | | |
|--|-------|-----------|---|--|
| Maximum Input Power Demand Normal Mode (Recharge Mode) | | | Suggested External Overcurrent Protection | External Feeder Wire Size: Min. – Max. Per Phase |
| kVA | PF | Amps | Amps | AWG or kcmil at 75° C Temp. Rating |
| 89(100) | >0.99 | 107 (120) | 150 A | 1/0 – (2) x 2/0 |

| Alternate (Bypass) AC Input (480V 3-Phase / 4-Wire) | | | | |
|---|-----|------|---|---|
| Maximum Input Power Demand | | | Suggested External Overcurrent Protection | External Feeder Wire Size: Min. – Max. Per Phase // Min. – Max. for Neutral |
| kVA | PF | Amps | Amps | AWG or kcmil at 75° C Temp. Rating |
| 80 | 1.0 | 96 | 125 AT | 1/0 – (2) x 2/0 // (2) x 1/0 – (2) x 2/0 |

| DC Backup Input (Battery - 360VDC Nom./Flywheel 550VDC Nom.) | | | | |
|--|----------------------------------|---------------------------------------|--|--|
| Backup System | DC Capacity for Full Load Output | Maximum Discharge at Full Load Output | Suggested External Overcurrent Protection* | External Feeder Wire Size: Min. – Max. |
| | kWB | Amps DC | Amps | AWG or kcmil at 75° C Temp. Rating |
| Battery | 88 | 292 | 300 A | (2) x 1/0 – (2) x 3/0 |
| Flywheel | 88 | 158 | 175 A | 2/0 |

* If required. Most Battery and Flywheel Cabinets are equipped with built-in breakers.

| AC Output (480/277V 3-Phase / 4-Wire) | | | | |
|---------------------------------------|-----|------|---|---|
| Rated Output Power | | | Suggested External Overcurrent Protection | External Feeder Wire Size: Min. – Max. Per Phase // Min. – Max. for Neutral |
| kVA | PF | Amps | Amps | AWG or kcmil at 75° C Temp. Rating |
| 80 | 1.0 | 96 | 125 A | 1/0 – (2) x 2/0 // (2) x 1/0 – (2) x 2/0 |

Important Notes:

- CABLE ACCESS – Bottom only.
- Maximum Current required at Primary AC Input based on full load output and maximum battery charging current.
- Output load conductors are to be installed in separate conduit from input conductors.
- Control wires and power wires are to be installed in separate conduits.
- Recommended AC input and output overcurrent protection based on continuous full load current per NEC.
- Wiring shall comply with all applicable national and local electrical codes.
- Grounding conductors to be sized per NEC Article 250-122. Neutral conductors to be sized per NEC Article 310.15.
 - Primary AC Input: 3 ϕ , 3-wire + ground.
 - Alternate AC Input: 3 ϕ , 4-wire + ground.
 - AC Output: 3 ϕ , 4-wire + ground.
 - DC Input: 2-wire (Positive/Negative) + ground.
- Nominal battery voltage based on the use of VRLA type batteries (2.0 volts/cell nominal).
- Maximum battery discharge current based on lowest permissible discharge voltage of 1.67 VPC.
- DC wires should be sized to allow not more than a 2-volt drop at maximum discharge current.
- Weights do not include batteries or other auxiliary equipment external to the UPS.

- Cable sizing calculations based on the following assumptions:
 - Minimum size is smallest size based on ampacity at 30 °C.
 - Maximum size cable is based on cable bend radius limitations at the UPS terminals.
 - Neutral sized for 2X phase current.
 - Not more than 3 current-carrying conductors installed in conduit in ambient temperature of 30 °C.
 - Temperature rating of copper conductors/terminals: 75 °C.
 - Reference: 2005 NEC Handbook, Table 310.16.

NOTE: Consult latest edition of applicable national and local codes for possible variations.
- Ratings of wires and overcurrent devices are suggested minimums. Consult with a registered Professional Engineer within your local area for proper size selections.

TOSHIBA INTERNATIONAL CORPORATION
13131 West Little York Road
Houston, TX 77041
Telephone: (877) 867-8773
Fax: (713) 896-5212
Web Site: www.toshiba.com/ind

TOSHIBA G8000 Series UPS

Installation Planning Guide for 80kVA UPS

Standard System: 480V Input, 480Y/277V Output (P/N T80S3K08KK6XSxx)

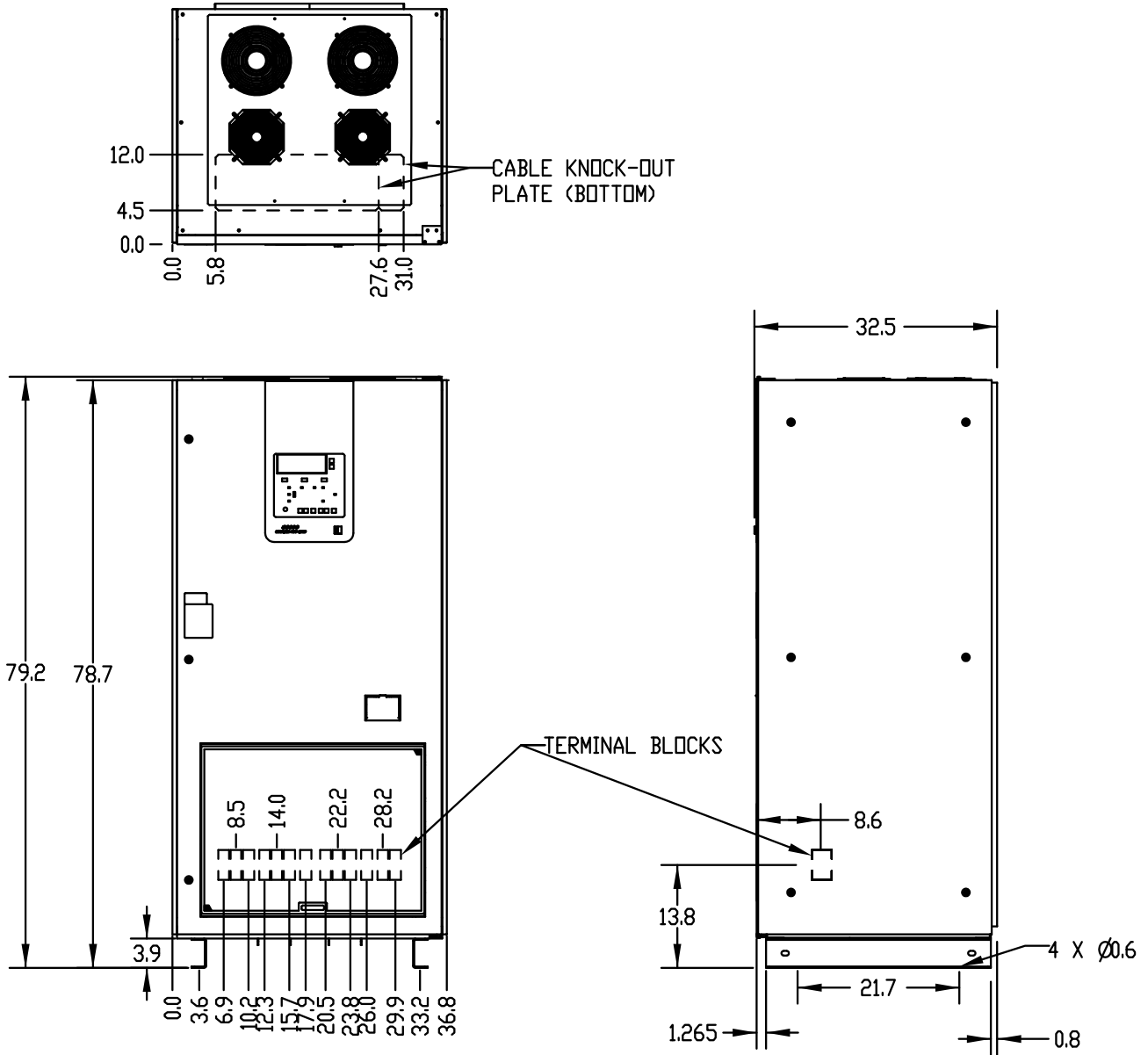

G8000 80KVA OUTLINE DRAWING

TOSHIBA G8000 Series UPS

Installation Planning Guide for 80kVA UPS

Standard System: 480V Input, 480Y/277V Output (P/N T80S3K08KK6XSxx)

Anchorage pattern:

Install anchor bolts to secure the UPS to the floor.

Use 1/2" (12mm) diameter anchor bolts. The UPS base has four pre-drilled 5/8" (16 mm) holes provided. See the figure below for dimensions and locations.

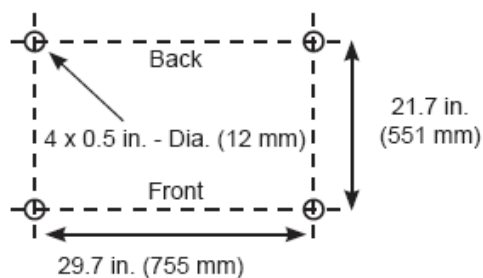

Anchorage Pattern for G8000 80kVA UPS

100kVA IPG

TOSHIBA G8000 Series UPS

Installation Planning Guide for 100kVA UPS

Standard System: 480V Input, 480Y/277V Output (P/N T80S3K10KK6XSxx)

| General Mechanical Information | | | | | | | | | |
|--------------------------------|--|--------|-----------------------|--------------------------------------|---|-------|--------|-------|------|
| Dimensions (W x D x H) | | Weight | Floor Loading | Approximate Full-Load Heat Rejection | Mechanical Clearance (Inches) from UPS for Ventilation and Maintenance Access | | | | |
| Inches | | Lbs. | Lbs./ft. ² | Btu/Hr | Top | Front | Bottom | Sides | Back |
| 36.8" x 32.5" x 79.2" | | 1,740 | 210 | 33,746 | 15.75" | 43.5" | 0" | 0" | 0" |

| Primary AC Input (480V 3-Phase / 3-Wire) | | | | |
|--|-------|-----------|---|--|
| Maximum Input Power Demand Normal Mode (Recharge Mode) | | | Suggested External Overcurrent Protection | External Feeder Wire Size: Min. – Max. Per Phase |
| kVA | PF | Amps | Amps | AWG or kcmil at 75° C Temp. Rating |
| 110 (122) | >0.99 | 134 (147) | 200 AT | (2) x #3 – (2) x 2/0 |

| Alternate (Bypass) AC Input (480V 3-Phase / 4-Wire) | | | | |
|---|-----|------|---|---|
| Maximum Input Power Demand | | | Suggested External Overcurrent Protection | External Feeder Wire Size: Min. – Max. Per Phase // Min. – Max. for Neutral |
| kVA | PF | Amps | Amps | AWG or kcmil at 75° C Temp. Rating |
| 100 | 1.0 | 120 | 150 AT | (2) x #3 – (2) x 2/0 // (2) 2/0 |

| DC Backup Input (Battery - 360VDC Nominal) | | | | |
|--|----------------------------------|---------------------------------------|--|--|
| Backup System | DC Capacity for Full Load Output | Maximum Discharge at Full Load Output | Suggested External Overcurrent Protection* | External Feeder Wire Size: Min. – Max. |
| | kWB | Amps DC | Amps | AWG or kcmil at 75° C Temp. Rating |
| Battery | 108 | 359 | 350 A | (2) x 3/0 – (2) x 4/0 |

* If required. Most Battery Cabinets are equipped with built-in breakers.

| AC Output (480/277V 3-Phase / 4-Wire) | | | | |
|---------------------------------------|-----|------|---|---|
| Rated Output Power | | | Suggested External Overcurrent Protection | External Feeder Wire Size: Min. – Max. Per Phase // Min. – Max. for Neutral |
| kVA | PF | Amps | Amps | AWG or kcmil at 75° C Temp. Rating |
| 100 | 1.0 | 120 | 150 AT | (2) x #3 – (2) x 2/0 // (2) 2/0 |

Important Notes:

- CABLE ACCESS – Bottom only.
- Maximum Current required at Primary AC Input based on full load output and maximum battery charging current.
- Output load conductors are to be installed in separate conduit from input conductors.
- Control wires and power wires are to be installed in separate conduits.
- Recommended AC input and output overcurrent protection based on continuous full load current per NEC.
- Wiring shall comply with all applicable national and local electrical codes.
- Grounding conductors to be sized per NEC Article 250-122. Neutral conductors to be sized per NEC Article 310.15.
 - Primary AC Input: 3 ϕ , 3-wire + ground.
 - Alternate AC Input: 3 ϕ , 4-wire + ground.
 - AC Output: 3 ϕ , 4-wire + ground.
 - DC Input: 2-wire (Positive/Negative) + ground.
- Nominal battery voltage based on the use of VRLA type batteries (2.0 volts/cell nominal).
- Maximum battery discharge current based on lowest permissible discharge voltage of 1.67 VPC.
- DC wires should be sized to allow not more than a 2-volt drop at maximum discharge current.
- Weights do not include batteries or other auxiliary equipment external to the UPS.

- Cable sizing calculations based on the following assumptions:
 - Minimum size is smallest size based on ampacity at 30 °C.
 - Maximum size cable is based on cable bend radius limitations at the UPS terminals.
 - Neutral sized for 2X phase current.
 - Not more than 3 current-carrying conductors installed in conduit in ambient temperature of 30 °C.
 - Temperature rating of copper conductors/terminals: 75 °C.
 - Reference: 2005 NEC Handbook, Table 310.16.

NOTE: Consult latest edition of applicable national and local codes for possible variations.
- Ratings of wires and overcurrent devices are suggested minimums. Consult with a registered Professional Engineer within your local area for proper size selections.

TOSHIBA INTERNATIONAL CORPORATION
13131 West Little York Road
Houston, TX 77041
Telephone: (877) 867-8773
Fax: (713) 896-5212
Web Site: www.toshiba.com/ind

TOSHIBA G8000 Series UPS

Installation Planning Guide for 100kVA UPS

Standard System: 480V Input, 480Y/277V Output (P/N T80S3K10KK6XSxx)

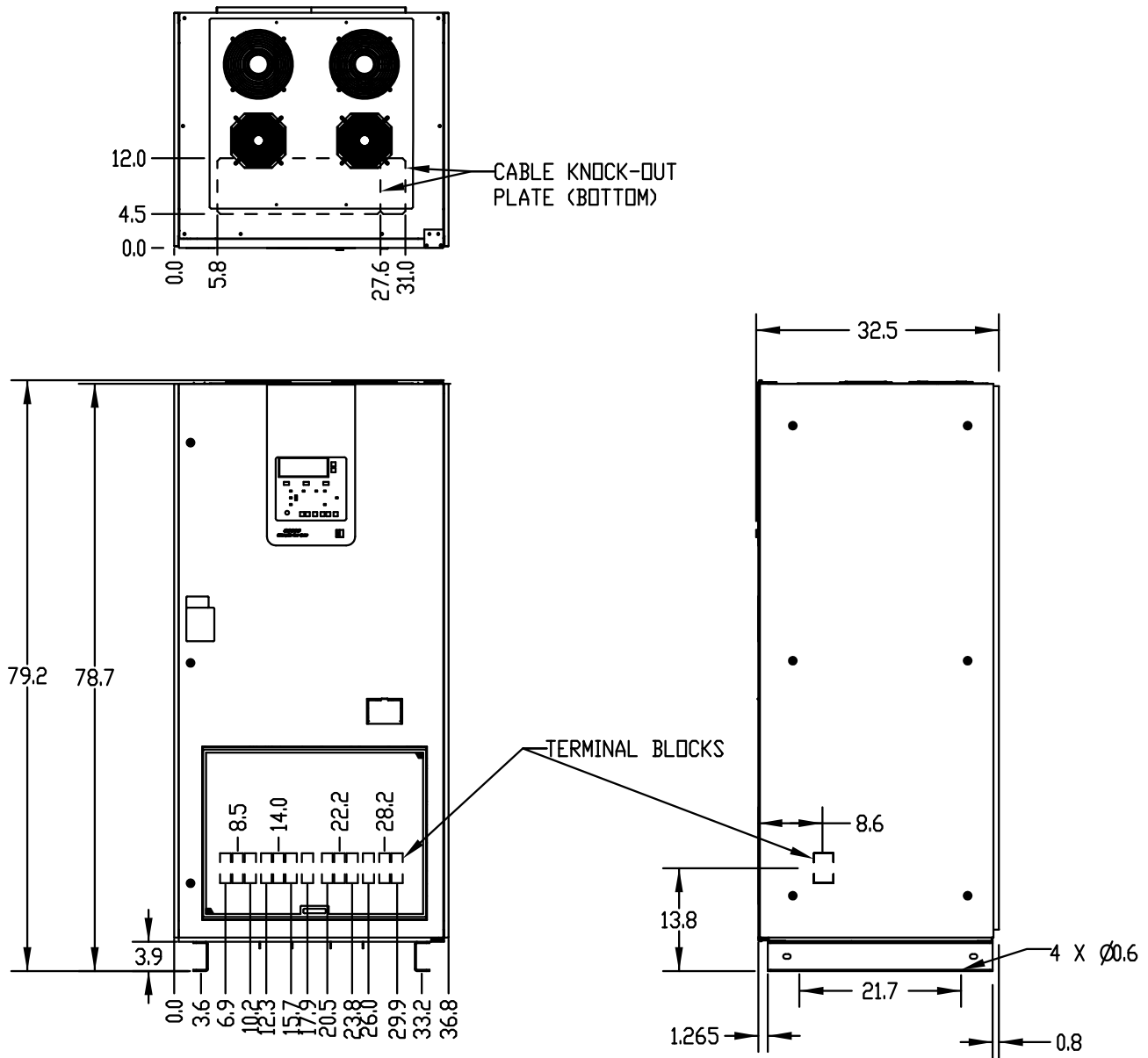

G8000 100KVA OUTLINE DRAWING

TOSHIBA G8000 Series UPS

Installation Planning Guide for 100kVA UPS

Standard System: 480V Input, 480Y/277V Output (P/N T80S3K10KK6XSxx)

Anchorage pattern:

Install anchor bolts to secure the UPS to the floor.

Use 1/2" (12mm) diameter anchor bolts. The UPS base has four pre-drilled 5/8" (16 mm) holes provided. See the figure below for dimensions and locations.

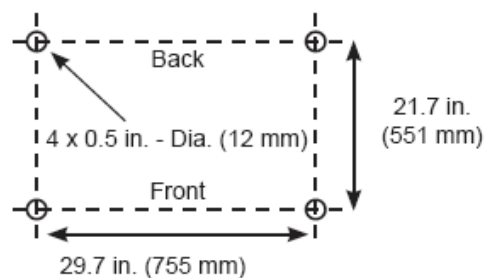

Anchorage Pattern for G8000 100kVA UPS

125kVA IPG

TOSHIBA G8000 Series UPS

Installation Planning Guide for 125kVA UPS

Standard System: 480V Input, 480Y/277V Output (P/N T80S3K12KK6XS2xx)

| General Mechanical Information | | | | | | | | |
|--------------------------------|--------|-----------------------|--------------------------------------|---|-------|--------|-------|------|
| Dimensions (W x D x H) | Weight | Floor Loading | Approximate Full-Load Heat Rejection | Mechanical Clearance (Inches) from UPS for Ventilation and Maintenance Access | | | | |
| Inches | Lbs. | Lbs./ft. ² | Btu/Hr | Top | Front | Bottom | Sides | Back |
| 36.8" x 32.5" x 79.2" | 1,740 | 210 | 33,746 | 15.75" | 43.5" | 0" | 0" | 0" |

| Primary AC Input (480V 3-Phase / 3-Wire) | | | | |
|--|-------|-----------|---|--|
| Maximum Input Power Demand Normal Mode (Recharge Mode) | | | Suggested External Overcurrent Protection | External Feeder Wire Size: Min. – Max. Per Phase |
| kVA | PF | Amps | Amps | AWG or kcmil at 75° C Temp. Rating |
| 112 (123) | >0.99 | 135 (148) | 200 AT | (2) x #3 – (2) x 2/0 |

| Alternate (Bypass) AC Input (480V 3-Phase / 4-Wire) | | | | |
|---|-----|------|---|---|
| Maximum Input Power Demand | | | Suggested External Overcurrent Protection | External Feeder Wire Size: Min. – Max. Per Phase // Min. – Max. for Neutral |
| kVA | PF | Amps | Amps | AWG or kcmil at 75° C Temp. Rating |
| 125 | 0.8 | 150 | 200 AT | (2) x #1 – (2) x 2/0 // (2) 2/0 |

| DC Backup Input (Battery - 360VDC Nominal) | | | | |
|--|----------------------------------|---------------------------------------|--|--|
| Backup System | DC Capacity for Full Load Output | Maximum Discharge at Full Load Output | Suggested External Overcurrent Protection* | External Feeder Wire Size: Min. – Max. |
| | kWB | Amps DC | Amps | AWG or kcmil at 75° C Temp. Rating |
| Battery | 110 | 365 | 400 A | (2) x 3/0 – (2) x 4 /0 |

* If required. Most Battery Cabinets are equipped with built-in breakers.

| AC Output (480/277V 3-Phase / 4-Wire) | | | | |
|---------------------------------------|-----|------|---|---|
| Rated Output Power | | | Suggested External Overcurrent Protection | External Feeder Wire Size: Min. – Max. Per Phase // Min. – Max. for Neutral |
| kVA | PF | Amps | Amps | AWG or kcmil at 75° C Temp. Rating |
| 125 | 0.8 | 150 | 200 AT | (2) x #1 – (2) x 2/0 // (2) 2/0 |

| | |
|--|--|
| <p>Important Notes:</p> <ol style="list-style-type: none"> CABLE ACCESS – Bottom only. Maximum Current required at Primary AC Input based on full load output and maximum battery charging current. Output load conductors are to be installed in separate conduit from input conductors. Control wires and power wires are to be installed in separate conduits. Recommended AC input and output overcurrent protection based on continuous full load current per NEC. Wiring shall comply with all applicable national and local electrical codes. Grounding conductors to be sized per NEC Article 250-122. Neutral conductors to be sized per NEC Article 310.15. <ul style="list-style-type: none"> Primary AC Input: 3φ, 3-wire + ground. Alternate AC Input: 3φ, 4-wire + ground. AC Output: 3φ, 4-wire + ground. DC Input: 2-wire (Positive/Negative) + ground. Nominal battery voltage based on the use of VRLA type batteries (2.0 volts/cell nominal). Maximum battery discharge current based on lowest permissible discharge voltage of 1.67 VPC. DC wires should be sized to allow not more than a 2-volt drop at maximum discharge current. Weights do not include batteries or other auxiliary equipment external to the UPS. | <ol style="list-style-type: none"> Cable sizing calculations based on the following assumptions: <ul style="list-style-type: none"> Minimum size is smallest size based on ampacity at 30 °C. Maximum size cable is based on cable bend radius limitations at the UPS terminals. Neutral sized for 2X phase current. Not more than 3 current-carrying conductors installed in conduit in ambient temperature of 30 °C. Temperature rating of copper conductors/terminals: 75 °C. Reference: 2005 NEC Handbook, Table 310.16. <p>NOTE: Consult latest edition of applicable national and local codes for possible variations.</p> Ratings of wires and overcurrent devices are suggested minimums. Consult with a registered Professional Engineer within your local area for proper size selections. |
|--|--|

TOSHIBA INTERNATIONAL CORPORATION
13131 West Little York Road
Houston, TX 77041
Telephone: (877) 867-8773
Fax: (713) 896-5212
Web Site: www.toshiba.com/ind

TOSHIBA G8000 Series UPS

Installation Planning Guide for 125kVA UPS

Standard System: 480V Input, 480Y/277V Output (P/N T80S3K12KK6XS2xx)

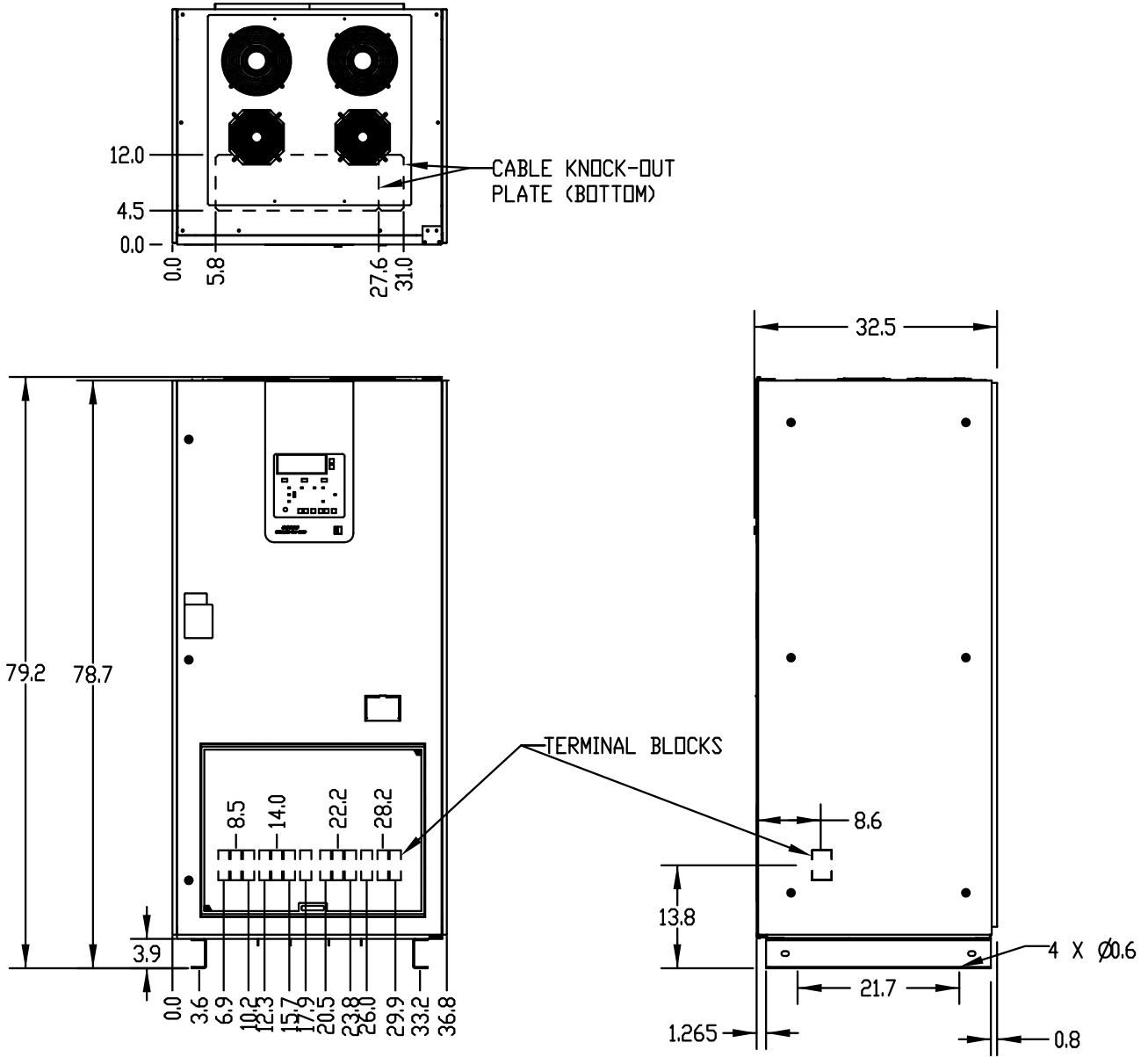

G8000 125KVA OUTLINE DRAWING

TOSHIBA G8000 Series UPS

Installation Planning Guide for 125kVA UPS

Standard System: 480V Input, 480Y/277V Output (P/N T80S3K12KK6XS2xx)

Anchorage pattern:

Install anchor bolts to secure the UPS to the floor.

Use 1/2" (12mm) diameter anchor bolts. The UPS base has four pre-drilled 5/8" (16 mm) holes provided. See the figure below for dimensions and locations.

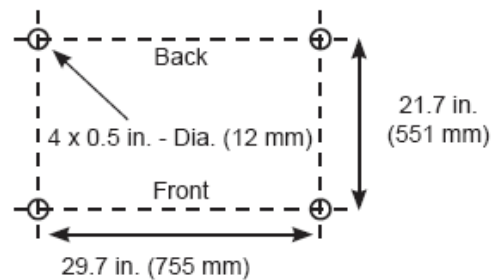

Anchorage Pattern for G8000 100kVA UPS

150kVA IPG

TOSHIBA G8000 Series UPS

Installation Planning Guide for 150kVA UPS

Standard System: 480V Input, 480Y/277V Output (P/N T80S3K15KK6XSxx)

| General Mechanical Information | | | | | | | | | |
|--------------------------------|--|--------|-----------------------|--------------------------------------|---|-------|--------|-------|------|
| Dimensions (W x D x H) | | Weight | Floor Loading | Approximate Full-Load Heat Rejection | Mechanical Clearance (Inches) from UPS for Ventilation and Maintenance Access | | | | |
| Inches | | Lbs. | Lbs./ft. ² | Btu/Hr | Top | Front | Bottom | Sides | Back |
| 55.1" x 31.8" x 79.2" | | 2,467 | 203 | 38,754 | 15.75" | 43.5" | 0" | 0" | 0" |

| Primary AC Input (480V 3-Phase / 3-Wire) | | | | |
|--|-------|-----------|---|--|
| Maximum Input Power Demand Normal Mode (Recharge Mode) | | | Suggested External Overcurrent Protection | External Feeder Wire Size: Min. – Max. Per Phase |
| kVA | PF | Amps | Amps | AWG or kcmil at 75° C Temp. Rating |
| 167 (183) | >0.99 | 196 (209) | 300 AT | 300 kcmil - (2) x #1 |

| Alternate (Bypass) AC Input (480V 3-Phase / 4-Wire) | | | | |
|---|-----|------|---|---|
| Maximum Input Power Demand | | | Suggested External Overcurrent Protection | External Feeder Wire Size: Min. – Max. Per Phase // Min. – Max. for Neutral |
| kVA | PF | Amps | Amps | AWG or kcmil at 75° C Temp. Rating |
| 150 | 1.0 | 180 | 250 AT | 300 kcmil - (2) x #1 // (2) x 300 kcmil - (4) x #1 |

| DC Backup Input (Battery - 360VDC Nom./Flywheel 550VDC Nom.) | | | | |
|--|----------------------------------|---------------------------------------|--|--|
| Backup System | DC Capacity for Full Load Output | Maximum Discharge at Full Load Output | Suggested External Overcurrent Protection* | External Feeder Wire Size: Min. – Max. |
| | kWB | Amps DC | Amps | AWG or kcmil at 75° C Temp. Rating |
| Battery | 160 | 533 | 600 A | (2) x 300 kcmil – (2) x 350 kcmil |

* If required. Most Battery and Flywheel Cabinets are equipped with built-in breakers.

| AC Output (480/277V 3-Phase / 4-Wire) | | | | |
|---------------------------------------|-----|------|---|---|
| Rated Output Power | | | Suggested External Overcurrent Protection | External Feeder Wire Size: Min. – Max. Per Phase // Min. – Max. for Neutral |
| kVA | PF | Amps | Amps | AWG or kcmil at 75° C Temp. Rating |
| 150 | 1.0 | 180 | 225 AT | 300 kcmil - (2) x #1 // (2) x 300 kcmil - (4) x #1 |

Important Notes:

- CABLE ACCESS – Top and Bottom.
- Maximum Current required at Primary AC Input based on full load output and maximum battery charging current.
- Output load conductors are to be installed in separate conduit from input conductors.
- Control wires and power wires are to be installed in separate conduits.
- Recommended AC input and output overcurrent protection based on continuous full load current per NEC.
- Wiring shall comply with all applicable national and local electrical codes.
- Grounding conductors to be sized per NEC Article 250-122. Neutral conductors to be sized per NEC Article 310.15.
 - Primary AC Input: 3 ϕ , 3-wire + ground.
 - Alternate AC Input: 3 ϕ , 4-wire + ground.
 - AC Output: 3 ϕ , 4-wire + ground.
 - DC Input: 2-wire (Positive/Negative) + ground.
- Nominal battery voltage based on the use of VRLA type batteries (2.0 volts/cell nominal).
- Maximum battery discharge current based on lowest permissible discharge voltage of 1.67 VPC.
- DC wires should be sized to allow not more than a 2-volt drop at maximum discharge current.
- Weights do not include batteries or other auxiliary equipment external to the UPS.

- Cable sizing calculations based on the following assumptions:
 - Minimum size is smallest size based on ampacity at 30 °C.
 - Maximum size cable is based on cable bend radius limitations at the UPS terminals.
 - Neutral sized for 2X phase current.
 - Not more than 3 current-carrying conductors installed in conduit in ambient temperature of 30 °C.
 - Temperature rating of copper conductors/terminals: 75 °C.
 - Reference: 2005 NEC Handbook, Table 310.16.

NOTE: Consult latest edition of applicable national and local codes for possible variations.
- Ratings of wires and overcurrent devices are suggested minimums. Consult with a registered Professional Engineer within your local area for proper size selections.

TOSHIBA INTERNATIONAL CORPORATION
13131 West Little York Road
Houston, TX 77041
Telephone: (877) 867-8773
Fax: (713) 896-5212
Web Site: www.toshiba.com/ind

TOSHIBA G8000 Series UPS

Installation Planning Guide for 150kVA UPS

Standard System: 480V Input, 480Y/277V Output (P/N T80S3K15KK6XSxx)

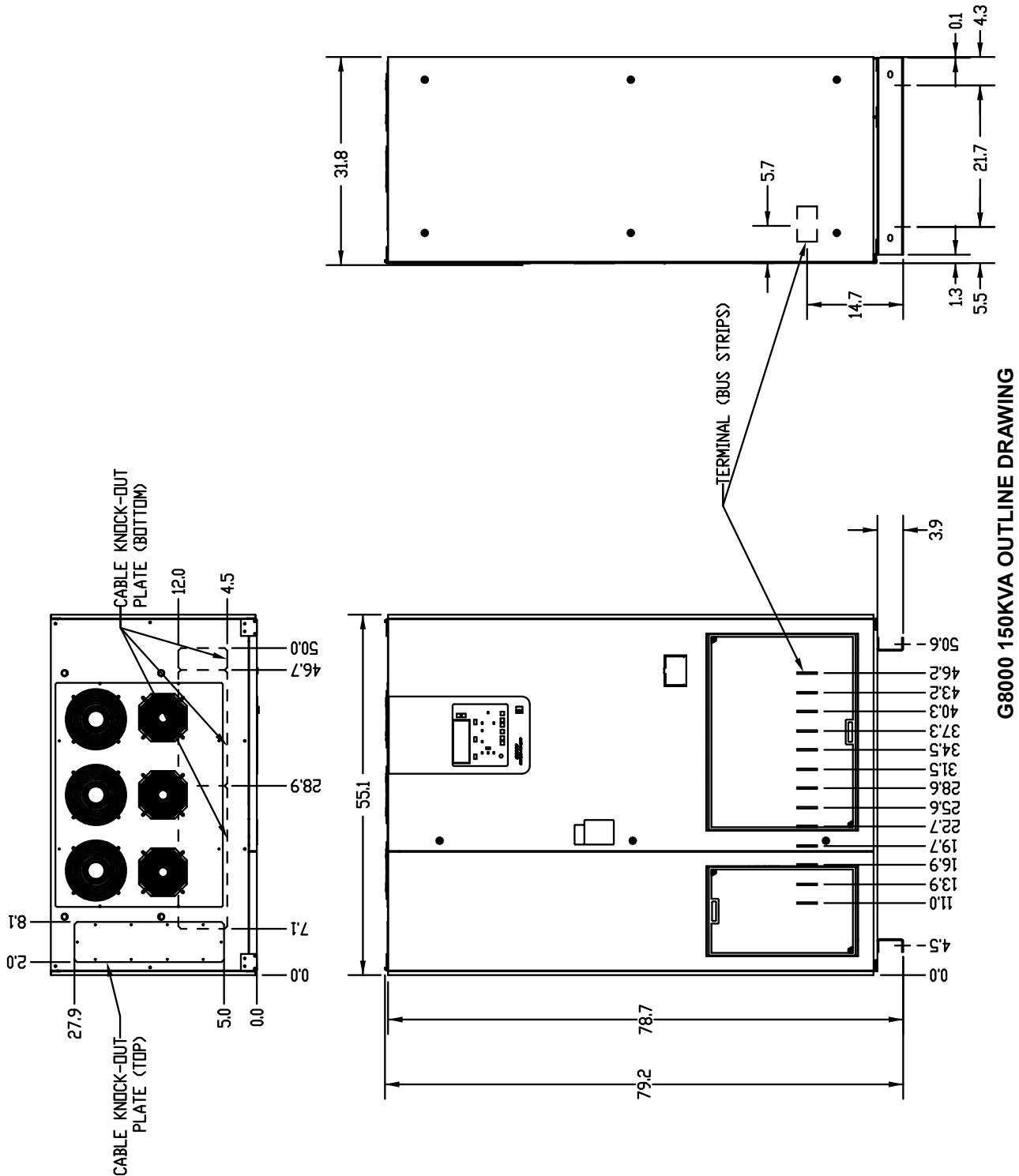

G8000 150KVA OUTLINE DRAWING

TOSHIBA G8000 Series UPS

Installation Planning Guide for 150kVA UPS

Standard System: 480V Input, 480Y/277V Output (P/N T80S3K15KK6XSxx)

Anchorage pattern:

Install anchor bolts to secure the UPS to the floor.

Use 1/2" (12mm) diameter anchor bolts. The UPS base has four pre-drilled 5/8" (16 mm) holes provided. See the figure below for dimensions and locations.

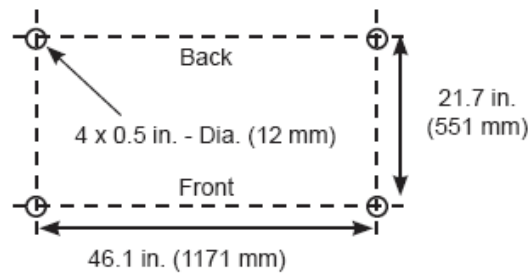

Anchorage Pattern for G8000 150kVA UPS

225kVA IPG

TOSHIBA G8000 Series UPS

Installation Planning Guide for 225kVA UPS

Standard System: 480V Input, 480Y/277V Output (P/N T80S3K22KK6XSxx)

| General Mechanical Information | | | | | | | | | |
|--------------------------------|--|--------|-----------------------|--------------------------------------|---|-------|--------|-------|------|
| Dimensions (W x D x H) | | Weight | Floor Loading | Approximate Full-Load Heat Rejection | Mechanical Clearance (Inches) from UPS for Ventilation and Maintenance Access | | | | |
| Inches | | Lbs. | Lbs./ft. ² | Btu/Hr | Top | Front | Bottom | Sides | Back |
| 55.1" x 31.8" x 79.2" | | 2,980 | 245 | 67,667 | 15.75" | 43.5" | 0" | 0" | 0" |

| Primary AC Input (480V 3-Phase / 3-Wire) | | | | |
|--|-------|-----------|---|--|
| Maximum Input Power Demand Normal Mode (Recharge Mode) | | | Suggested External Overcurrent Protection | External Feeder Wire Size: Min. – Max. Per Phase |
| kVA | PF | Amps | Amps | AWG or kcmil at 75° C Temp. Rating |
| 247 (258) | >0.99 | 297 (311) | 400 AT | (2) x 3/0 – (2) x 4/0 |

| Alternate (Bypass) AC Input (480V 3-Phase / 4-Wire) | | | | |
|---|-----|------|---|---|
| Maximum Input Power Demand | | | Suggested External Overcurrent Protection | External Feeder Wire Size: Min. – Max. Per Phase // Min. – Max. for Neutral |
| kVA | PF | Amps | Amps | AWG or kcmil at 75° C Temp. Rating |
| 225 | 1.0 | 271 | 350 AT | (2) x 4/0 – (2) x 250 kcmil // (4) x 4/0 – (4) x 250 kcmil |

| DC Backup Input (Battery - 360VDC Nom./Flywheel 550VDC Nom.) | | | | |
|--|----------------------------------|---------------------------------------|--|--|
| Backup System | DC Capacity for Full Load Output | Maximum Discharge at Full Load Output | Suggested External Overcurrent Protection* | External Feeder Wire Size: Min. – Max. |
| | kWB | Amps DC | Amps | AWG or kcmil at 75° C Temp. Rating |
| Battery | 242 | 805 | 900 A | (4) x 4/0 – (4) x 250 kcmil |

* If required. Most Battery and Flywheel Cabinets are equipped with built-in breakers.

| AC Output (480/277V 3-Phase / 4-Wire) | | | | |
|---------------------------------------|-----|------|---|---|
| Rated Output Power | | | Suggested External Overcurrent Protection | External Feeder Wire Size: Min. – Max. Per Phase // Min. – Max. for Neutral |
| kVA | PF | Amps | Amps | AWG or kcmil at 75° C Temp. Rating |
| 225 | 1.0 | 271 | 350 AT | (2) x 4/0 – (2) x 250 kcmil // (4) x 4/0 – (4) x 250 kcmil |

Important Notes:

- CABLE ACCESS – Top and Bottom.
- Maximum Current required at Primary AC Input based on full load output and maximum battery charging current.
- Output load conductors are to be installed in separate conduit from input conductors.
- Control wires and power wires are to be installed in separate conduits.
- Recommended AC input and output overcurrent protection based on continuous full load current per NEC.
- Wiring shall comply with all applicable national and local electrical codes.
- Grounding conductors to be sized per NEC Article 250-122. Neutral conductors to be sized per NEC Article 310.15.
 - Primary AC Input: 3 ϕ , 3-wire + ground.
 - Alternate AC Input: 3 ϕ , 4-wire + ground.
 - AC Output: 3 ϕ , 4-wire + ground.
 - DC Input: 2-wire (Positive/Negative) + ground.
- Nominal battery voltage based on the use of VRLA type batteries (2.0 volts/cell nominal).
- Maximum battery discharge current based on lowest permissible discharge voltage of 1.67 VPC.
- DC wires should be sized to allow not more than a 2-volt drop at maximum discharge current.
- Weights do not include batteries or other auxiliary equipment external to the UPS.

- Cable sizing calculations based on the following assumptions:
 - Minimum size is smallest size based on ampacity at 30 °C.
 - Maximum size cable is based on cable bend radius limitations at the UPS terminals.
 - Neutral sized for 2X phase current.
 - Not more than 3 current-carrying conductors installed in conduit in ambient temperature of 30 °C.
 - Temperature rating of copper conductors/terminals: 75 °C.
 - Reference: 2005 NEC Handbook, Table 310.16.

NOTE: Consult latest edition of applicable national and local codes for possible variations.
- Ratings of wires and overcurrent devices are suggested minimums. Consult with a registered Professional Engineer within your local area for proper size selections.

TOSHIBA INTERNATIONAL CORPORATION
13131 West Little York Road
Houston, TX 77041
Telephone: (877) 867-8773
Fax: (713) 896-5212
Web Site: www.toshiba.com/ind

TOSHIBA G8000 Series UPS

Installation Planning Guide for 225kVA UPS

Standard System: 480V Input, 480Y/277V Output (P/N T80S3K22KK6XSxx)

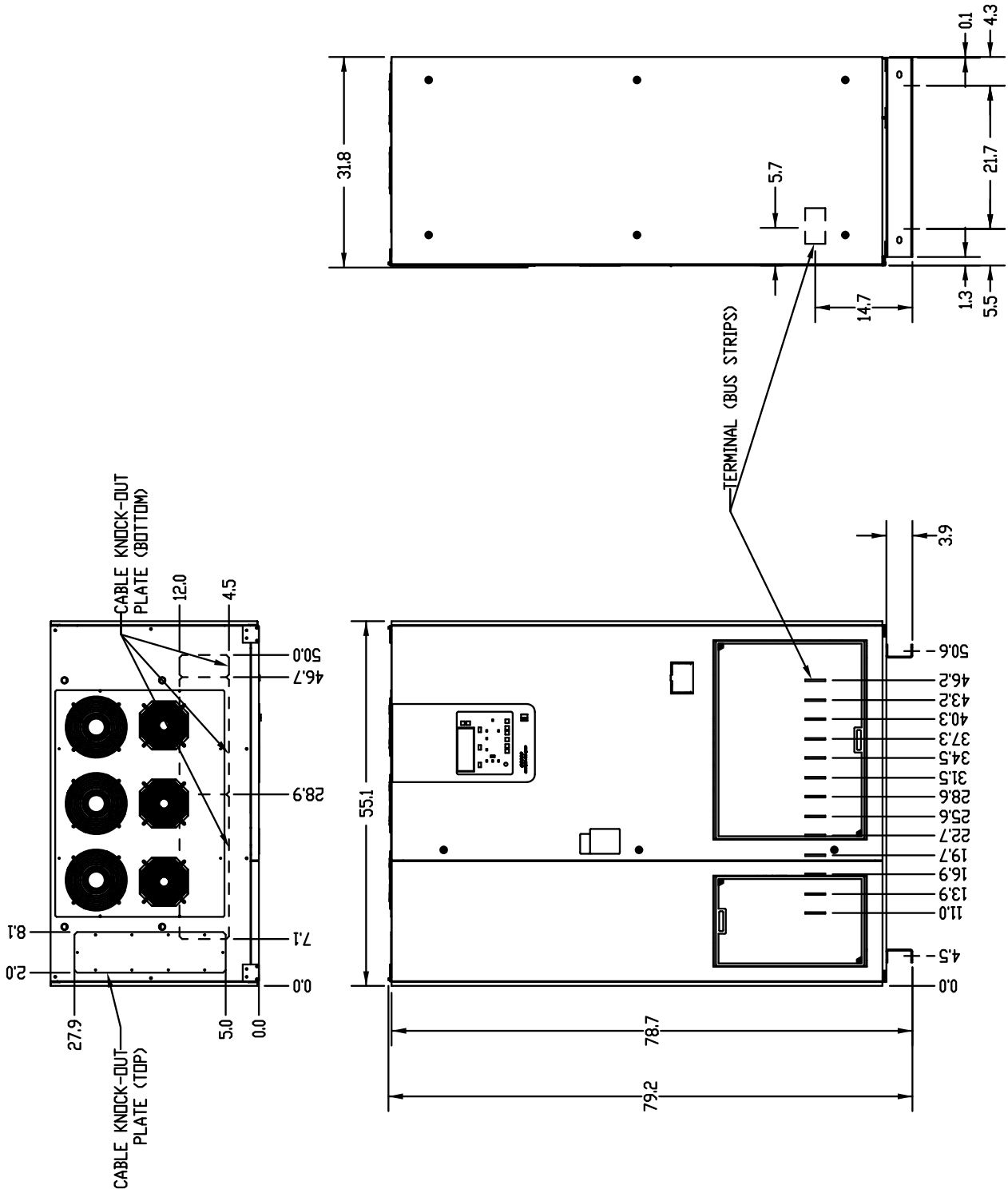

G8000 225 KVA OUTLINE DRAWING

TOSHIBA G8000 Series UPS

Installation Planning Guide for 225kVA UPS

Standard System: 480V Input, 480Y/277V Output (P/N T80S3K22KK6XSxx)

Anchorage pattern:

Install anchor bolts to secure the UPS to the floor.

Use 1/2" (12mm) diameter anchor bolts. The UPS base has four pre-drilled 5/8" (16 mm) holes provided. See the figure below for dimensions and locations.

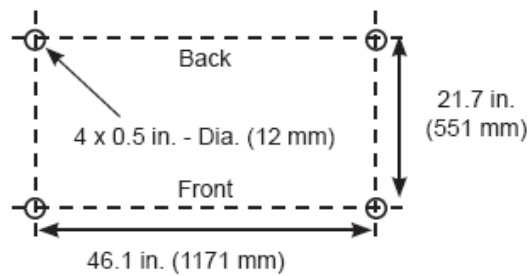

Anchorage Pattern for G8000 225kVA UPS

300kVA IPG

TOSHIBA G8000 Series UPS

Installation Planning Guide for 300kVA UPS

Standard System: 480V Input, 480Y/277V Output (P/N T80S3K30KK6XSxx)

| General Mechanical Information | | | | | | | | |
|--------------------------------|--|--------|-----------------------|--------------------------------------|---|-------|--------|------------|
| Dimensions (W x D x H) | | Weight | Floor Loading | Approximate Full-Load Heat Rejection | Mechanical Clearance (Inches) from UPS for Ventilation and Maintenance Access | | | |
| Inches | | Lbs. | Lbs./ft. ² | Btu/Hr | Top | Front | Bottom | Sides Back |
| 76.8" x 35.7" x 79.2" | | 4,575 | 240 | 89,011 | 15.75" | 43.5" | 0" | 0" 0" |

| Primary AC Input (480V 3-Phase / 3-Wire) | | | | |
|--|-------|-----------|---|--|
| Maximum Input Power Demand Normal Mode (Recharge Mode) | | | Suggested External Overcurrent Protection | External Feeder Wire Size: Min. – Max. Per Phase |
| kVA | PF | Amps | Amps | AWG or kcmil at 75° C Temp. Rating |
| 326 (329) | >0.99 | 396 (409) | 600 AT | (2) 250 kcmil – (3) x 2/0 |

| Alternate (Bypass) AC Input (480V 3-Phase / 4-Wire) | | | | |
|---|-----|------|---|---|
| Maximum Input Power Demand | | | Suggested External Overcurrent Protection | External Feeder Wire Size: Min. – Max. Per Phase // Min. – Max. for Neutral |
| kVA | PF | Amps | Amps | AWG or kcmil at 75° C Temp. Rating |
| 300 | 1.0 | 361 | 500 AT | (2) 300 kcmil – (3) x 2/0 (2) 300 kcmil // (4) x 300 kcmil – (6) x 2/0 |

| DC Backup Input (Battery - 360VDC Nom.) | | | | |
|---|----------------------------------|---------------------------------------|--|--|
| Backup System | DC Capacity for Full Load Output | Maximum Discharge at Full Load Output | Suggested External Overcurrent Protection* | External Feeder Wire Size: Min. – Max. |
| | kWB | Amps DC | Amps | AWG or kcmil at 75° C Temp. Rating |
| Battery | 323 | 1073 | 1200 A | (4) x 300 kcmil – (4) x 350 kcmil |

* If required. Most Battery Cabinets are equipped with built-in breakers.

| AC Output (480/277V 3-Phase / 4-Wire) | | | | |
|---------------------------------------|-----|------|---|---|
| Rated Output Power | | | Suggested External Overcurrent Protection | External Feeder Wire Size: Min. – Max. Per Phase // Min. – Max. for Neutral |
| kVA | PF | Amps | Amps | AWG or kcmil at 75° C Temp. Rating |
| 300 | 1.0 | 361 | 450 AT | (2) 300 kcmil – (3) x 2/0 (2) 300 kcmil // (4) x 300 kcmil – (6) x 2/0 |

| Important Notes: |
|--|
| <ol style="list-style-type: none"> CABLE ACCESS – Top only. Maximum Current required at Primary AC Input based on full load output and maximum battery charging current. Output load conductors are to be installed in separate conduit from input conductors. Control wires and power wires are to be installed in separate conduits. Recommended AC input and output overcurrent protection based on continuous full load current per NEC. Wiring shall comply with all applicable national and local electrical codes. Grounding conductors to be sized per NEC Article 250-122. Neutral conductors to be sized per NEC Article 310.15. <ul style="list-style-type: none"> - Primary AC Input: 3ϕ, 3-wire + ground. - Alternate AC Input: 3ϕ, 4-wire + ground. - AC Output: 3ϕ, 4-wire + ground. - DC Input: 2-wire (Positive/Negative) + ground. Nominal battery voltage based on the use of VRLA type batteries (2.0 volts/cell nominal). Maximum battery discharge current based on lowest permissible discharge voltage of 1.67 VPC. DC wires should be sized to allow not more than a 2-volt drop at maximum discharge current. Weights do not include batteries or other auxiliary equipment external to the UPS. |
| <ol style="list-style-type: none"> Cable sizing calculations based on the following assumptions: <ul style="list-style-type: none"> - Minimum size is smallest size based on ampacity at 30 °C. - Maximum size cable is based on cable bend radius limitations at the UPS terminals. - Neutral sized for 2X phase current. - Not more than 3 current-carrying conductors installed in conduit in ambient temperature of 30 °C. - Temperature rating of copper conductors/terminals: 75 °C. - Reference: 2005 NEC Handbook, Table 310.16. <p>NOTE: Consult latest edition of applicable national and local codes for possible variations.</p> Ratings of wires and overcurrent devices are suggested minimums. Consult with a registered Professional Engineer within your local area for proper size selections. |
| <p>TOSHIBA INTERNATIONAL CORPORATION 13131 West Little York Road Houston, TX 77041 Telephone: (877) 867-8773 Fax: (713) 896-5212 Web Site: www.toshiba.com/ind</p> |

TOSHIBA G8000 Series UPS

Installation Planning Guide for 300kVA UPS

Standard System: 480V Input, 480Y/277V Output (P/N T80S3K30KK6XSxx)

Anchorage pattern:

Install anchor bolts to secure the UPS to the floor.

Use 1/2" (12mm) diameter anchor bolts. The UPS base has eight pre-drilled 5/8" (16 mm) holes provided. See the figure below for dimensions and locations.

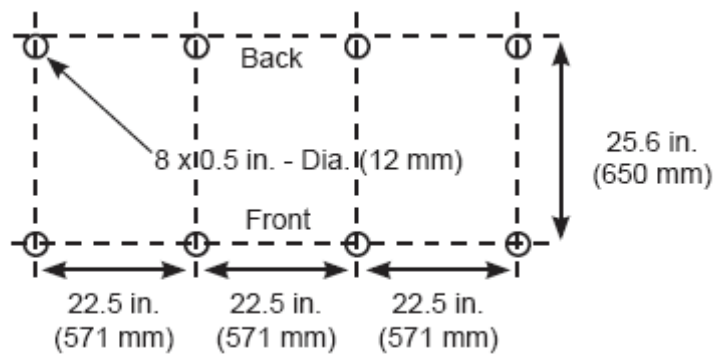

Anchorage Pattern for G8000 300kVA UPS

500kVA IPG

TOSHIBA G8000 Series UPS

Installation Planning Guide for 500kVA UPS

Standard System: 480V Input, 480Y/277V Output (P/N T80S3K50KK6XSxx)

| General Mechanical Information | | | | | | | | | |
|--------------------------------|--|--------|-----------------------|--------------------------------------|---|-------|--------|-------|------|
| Dimensions (W x D x H) | | Weight | Floor Loading | Approximate Full-Load Heat Rejection | Mechanical Clearance (Inches) from UPS for Ventilation and Maintenance Access | | | | |
| Inches | | Lbs. | Lbs./ft. ² | Btu/Hr | Top | Front | Bottom | Sides | Back |
| 101.8" x 37.4" x 79.7" | | 6520 | 247 | 101,490 | 15.75" | 37" | 0" | 0" | 0" |

| Primary AC Input (480V 3-Phase / 3-Wire) | | | | |
|--|-------|-----------|---|--|
| Maximum Input Power Demand Normal Mode (Recharge Mode) | | | Suggested External Overcurrent Protection | External Feeder Wire Size: Min. – Max. Per Phase |
| kVA | PF | Amps | Amps | AWG or kcmil at 75° C Temp. Rating |
| 484 (505) | >0.99 | 582 (608) | 800 AT | (3) x 250 kcmil – (3) x 300 kcmil |

| Alternate (Bypass) AC Input (480V 3-Phase / 4-Wire) | | | | |
|---|-----|------|---|---|
| Maximum Input Power Demand | | | Suggested External Overcurrent Protection | External Feeder Wire Size: Min. – Max. Per Phase // Min. – Max. for Neutral |
| kVA | PF | Amps | Amps | AWG or kcmil at 75° C Temp. Rating |
| 500 | 0.9 | 601 | 800 AT | (3) x 400 kcmil – (3) x 500 kcmil // (6) x 400 kcmil – (6) x 500 kcmil |

| DC Backup Input (Battery - 480VDC Nom.) | | | | |
|---|----------------------------------|---------------------------------------|--|---|
| Backup System | DC Capacity for Full Load Output | Maximum Discharge at Full Load Output | Suggested External Overcurrent Protection* | External Feeder Wire Size/pole: Min. – Max. |
| | kWB | Amps DC | Amps | AWG or kcmil at 75° C Temp. Rating |
| Battery | 478 | 1193 | 1200 A | (3) x 400 kcmil – (3) x 500 kcmil |

* If required. Most Battery and Flywheel Cabinets are equipped with built-in breakers.

| AC Output (480/277V 3-Phase / 4-Wire) | | | | |
|---------------------------------------|-----|------|---|---|
| Rated Output Power | | | Suggested External Overcurrent Protection | External Feeder Wire Size: Min. – Max. Per Phase // Min. – Max. for Neutral |
| kVA | PF | Amps | Amps | AWG or kcmil at 75° C Temp. Rating |
| 500 | 0.9 | 601 | 800 AT | (3) x 400 kcmil – (3) x 500 kcmil // (6) x 400 kcmil – (6) x 500 kcmil |

| | |
|---|--|
| <p>Important Notes:</p> <ol style="list-style-type: none"> CABLE ACCESS – Top only. Maximum Current required at Primary AC Input based on full load output and maximum battery charging current. Output load conductors are to be installed in separate conduit from input conductors. Control wires and power wires are to be installed in separate conduits. Recommended AC input and output overcurrent protection based on continuous full load current per NEC. Wiring shall comply with all applicable national and local electrical codes. Grounding conductors to be sized per NEC Article 250-122. Neutral conductors to be sized per NEC Article 310.15. <ul style="list-style-type: none"> - Primary AC Input: 3φ, 3-wire + ground. - Alternate AC Input: 3φ, 4-wire + ground. - AC Output: 3φ, 4-wire + ground. - DC Input: 2-wire (Positive/Negative) + ground. Nominal battery voltage based on the use of VRLA type batteries (2.0 volts/cell nominal). Maximum battery discharge current based on lowest permissible discharge voltage of 1.67 VPC. DC wires should be sized to allow not more than a 2-volt drop at maximum discharge current. Weights do not include batteries or other auxiliary equipment external to the UPS. | <ol style="list-style-type: none"> Cable sizing calculations based on the following assumptions: <ul style="list-style-type: none"> - Minimum size is smallest size based on ampacity at 30 °C. - Maximum size cable is based on cable bend radius limitations at the UPS terminals. - Neutral sized for 1.7X phase current. - Not more than 3 current-carrying conductors installed in conduit in ambient temperature of 30 °C. - Temperature rating of copper conductors/terminals: 75 °C. - Reference: 2005 NEC Handbook, Table 310.16. <p>NOTE: Consult latest edition of applicable national and local codes for possible variations.</p> Ratings of wires and overcurrent devices are suggested minimums. Consult with a registered Professional Engineer within your local area for proper size selections. |
| <p>TOSHIBA INTERNATIONAL CORPORATION 13131 West Little York Road Houston, TX 77041 Telephone: (877) 867-8773 Fax: (713) 896-5212 Web Site: www.toshiba.com/ind</p> | |

TOSHIBA G8000 Series UPS

Installation Planning Guide for 500kVA UPS

Standard System: 480V Input, 480Y/277V Output (P/N T80S3K50KK6XSxx)

Anchorage pattern:

Install anchor bolts to secure the UPS to the floor.

Use 1/2" (12mm) diameter anchor bolts. The UPS base has eight pre-drilled 5/8" (16 mm) holes provided. See the figure below for dimensions and locations.

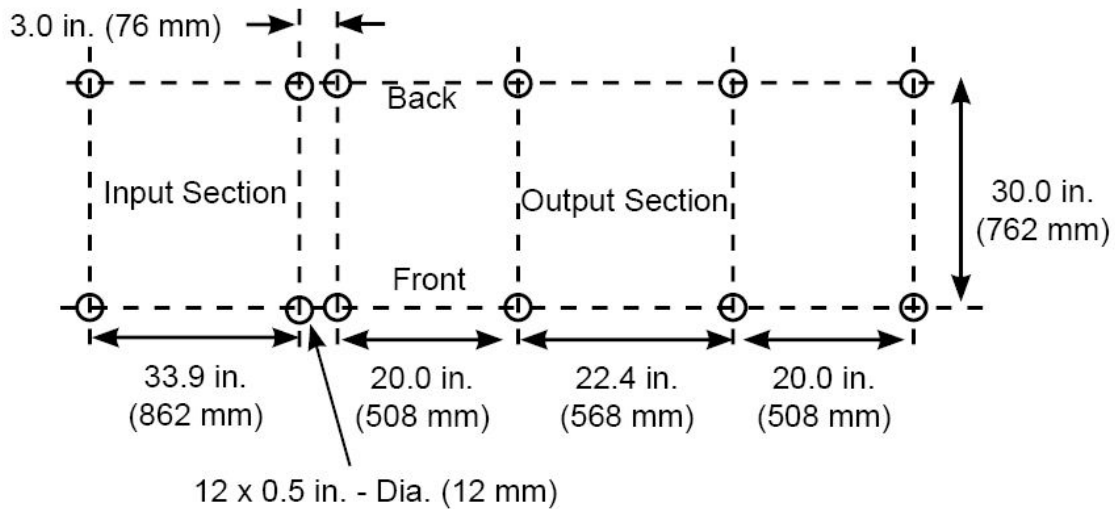

Anchorage Pattern for G8000 500kVA UPS

Appendix B - Outline Drawings

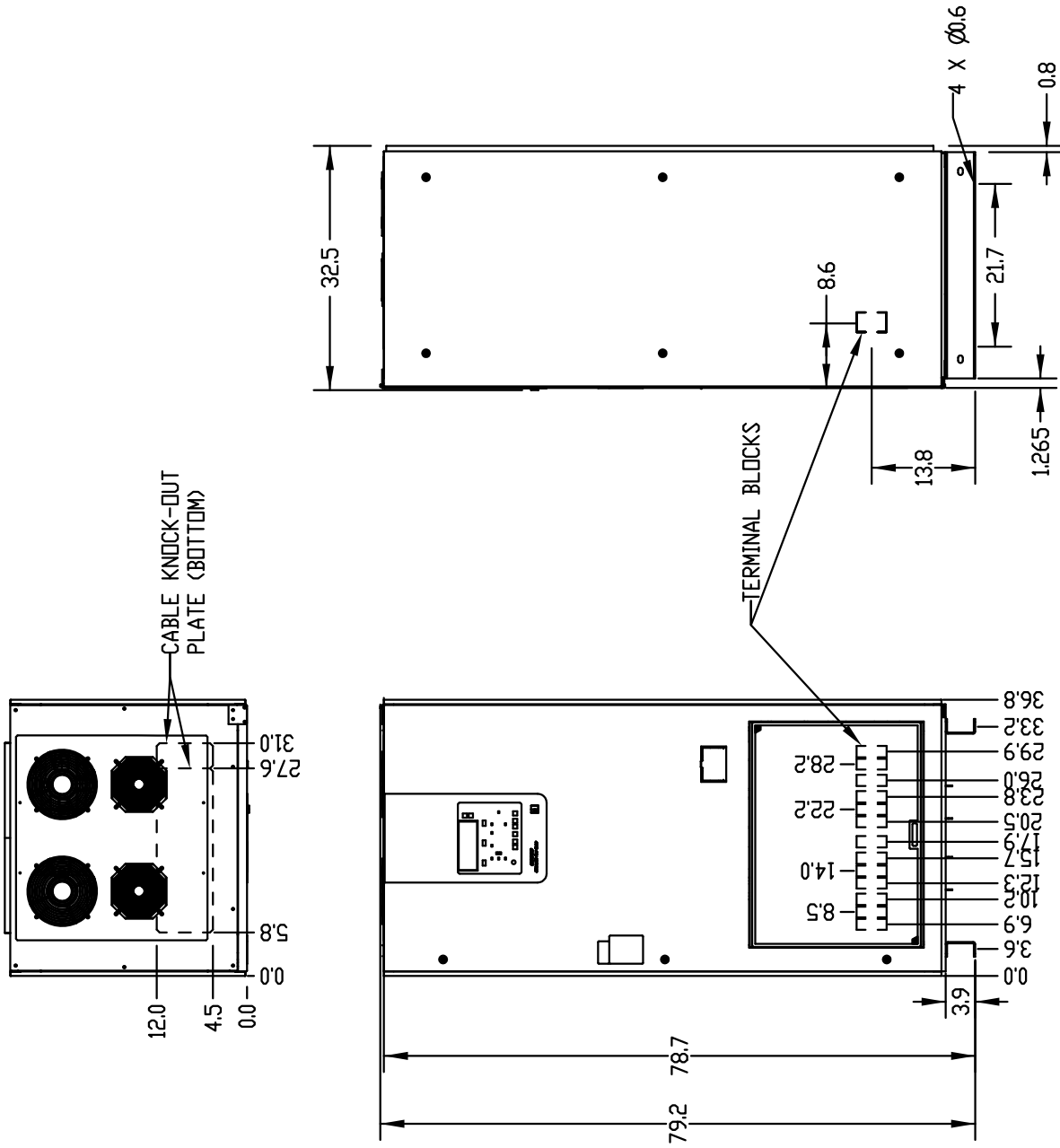

FIGURE B.1 - G8000 80/100/125 KVA OUTLINE DRAWING

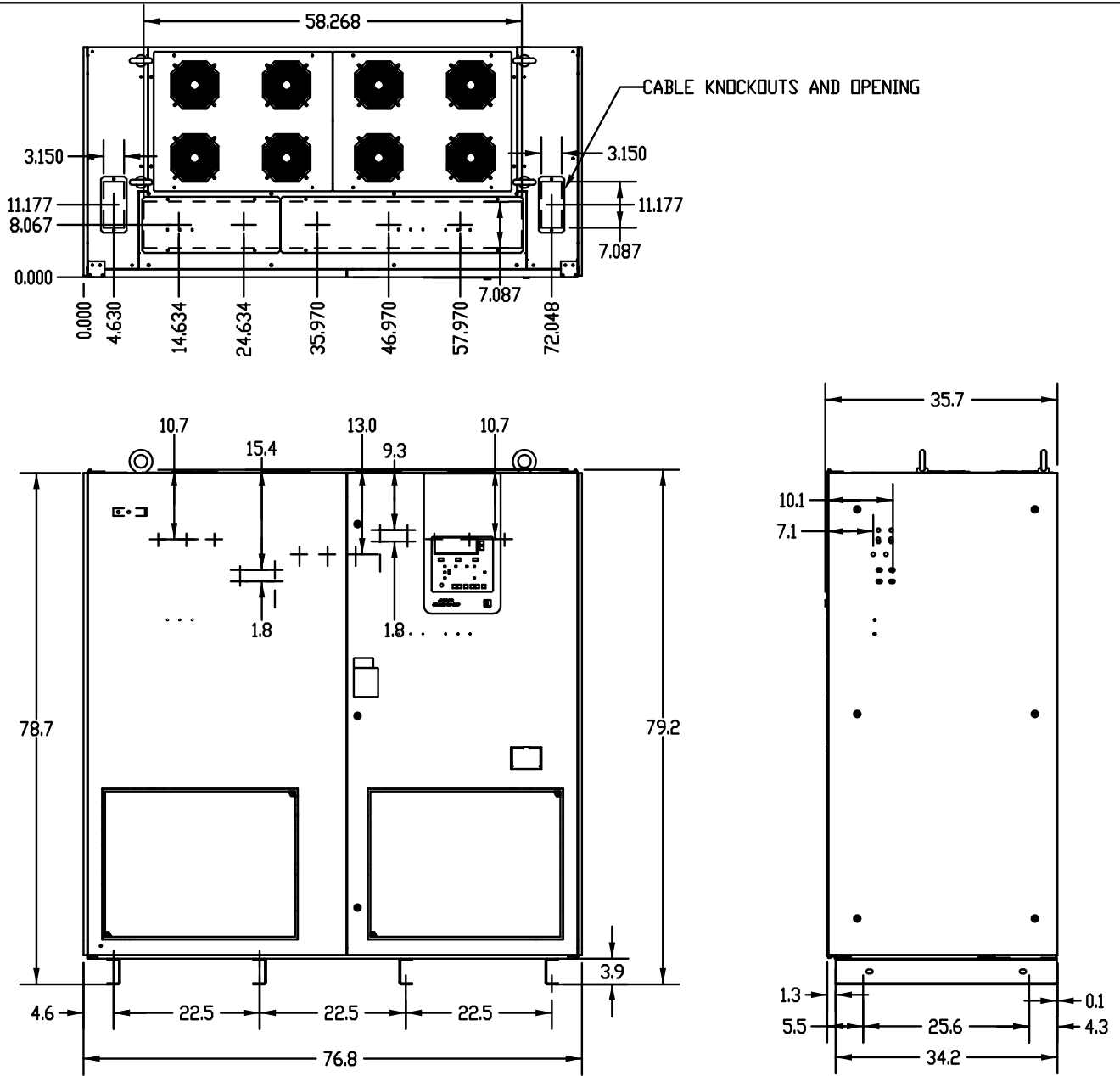

FIGURE B.3 - G8000 300 KVA OUTLINE DRAWING

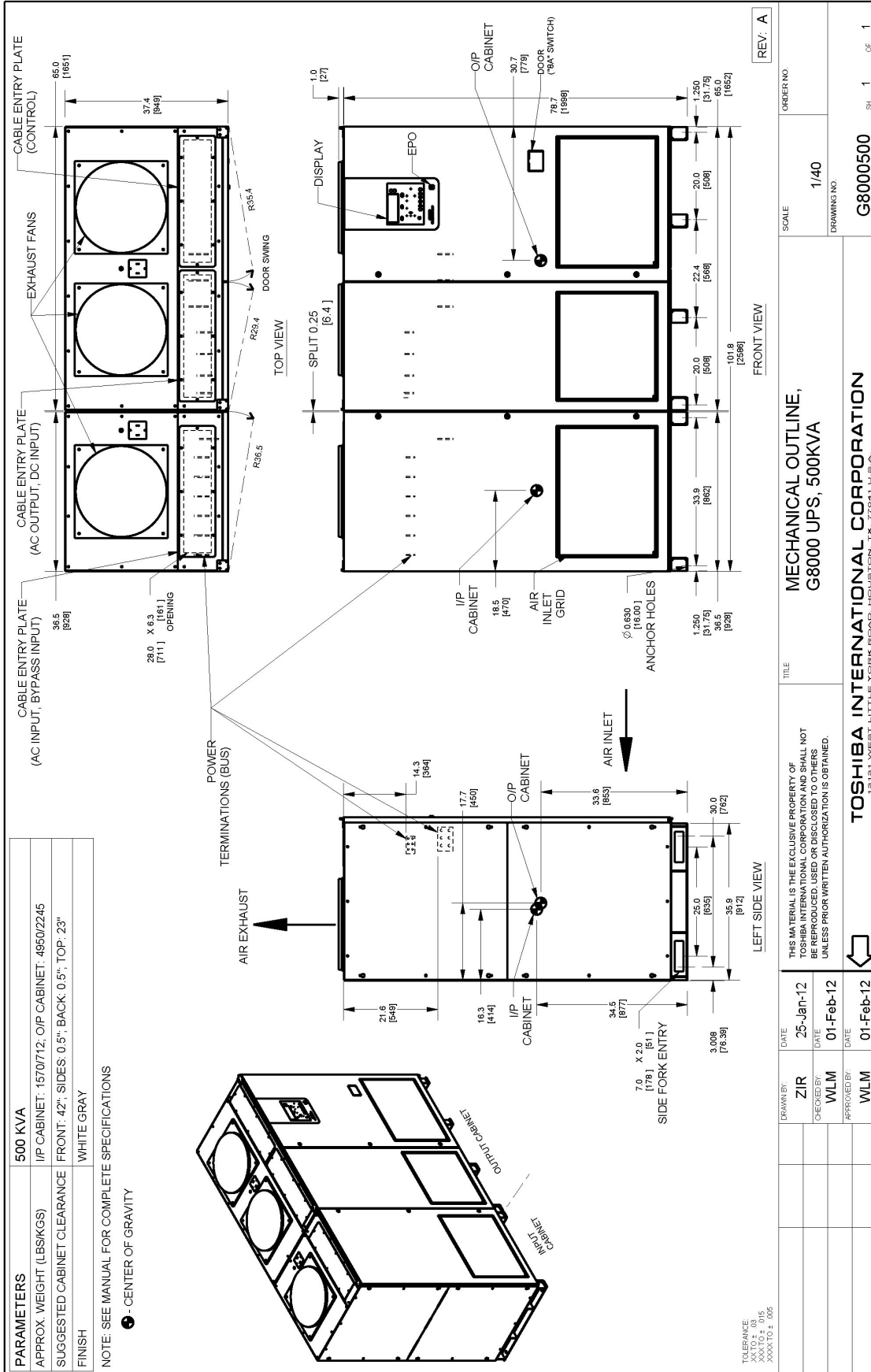
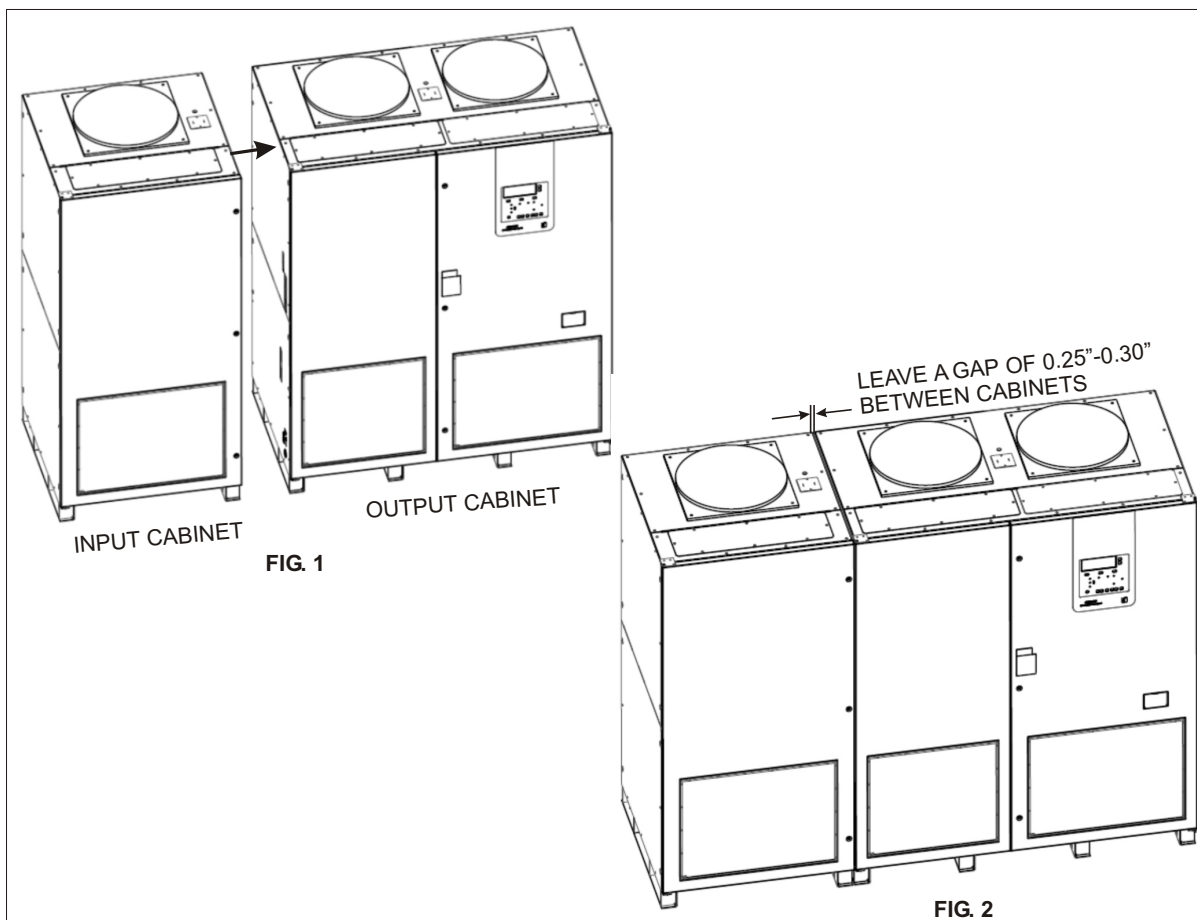

FIGURE B.4 - G8000 500 KVA OUTLINE DRAWING

Appendix C - 500kVA Input- and Output- Cabinet Joining Instructions

Joining the G8000 500kVA Sections

1. Remove Shipping Material (Retain Connection Kit Box and Manual).
2. On a leveled floor bring the two cabinets together. Input cabinet on the left side. See FIG. 1. Leave a gap of 0.25"-0.30" between the cabinets. See FIG. 2.



- 3.
4. On Input cabinet: Open the door, remove back panel (retain hardware). See FIG. 3. Insert 1/2-13X1.75" bolt, flat & lock washer assembly (supplied); two in the front and two in the back. See FIG. 4 & FIG. 5.

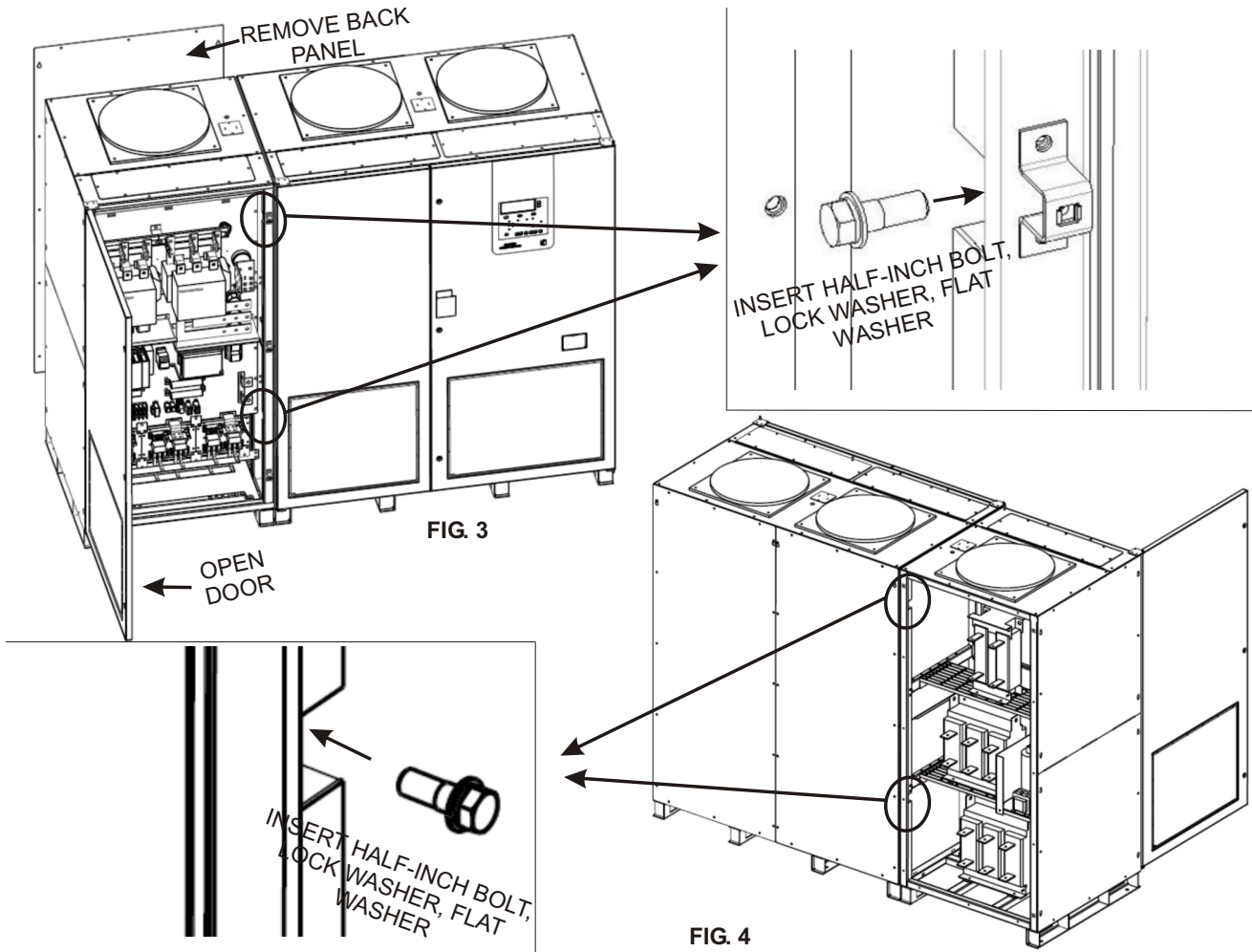

5. On Output cabinet: Open the door. Insert Neutral bus between the cabinets as shown in FIG. 5 & FIG. 6 and connect on corresponding output and input cabinet neutral bus using 3/8-16X1.25" bolt, flat, belleville washer and nut (supplied).

Insert Belleville washer between flat washer and nut.

6. Insert AC Bus (qty. 3) between the cabinets as shown in FIG. 5 & FIG. 6 and connect on corresponding output and input cabinet AC bus using 1/2-13X1.25" bolt, flat, belleville washer and nut (supplied).

Insert Belleville washer between flat washer and nut.

7. Insert DC Bus (qty. 2) between the cabinets as shown in FIG. 5 & FIG. 6 and connect on corresponding output and input cabinet DC bus using 1/2-13X1.25" bolt, flat, belleville washer and nut (supplied).

Insert Belleville washer between flat washer and nut.

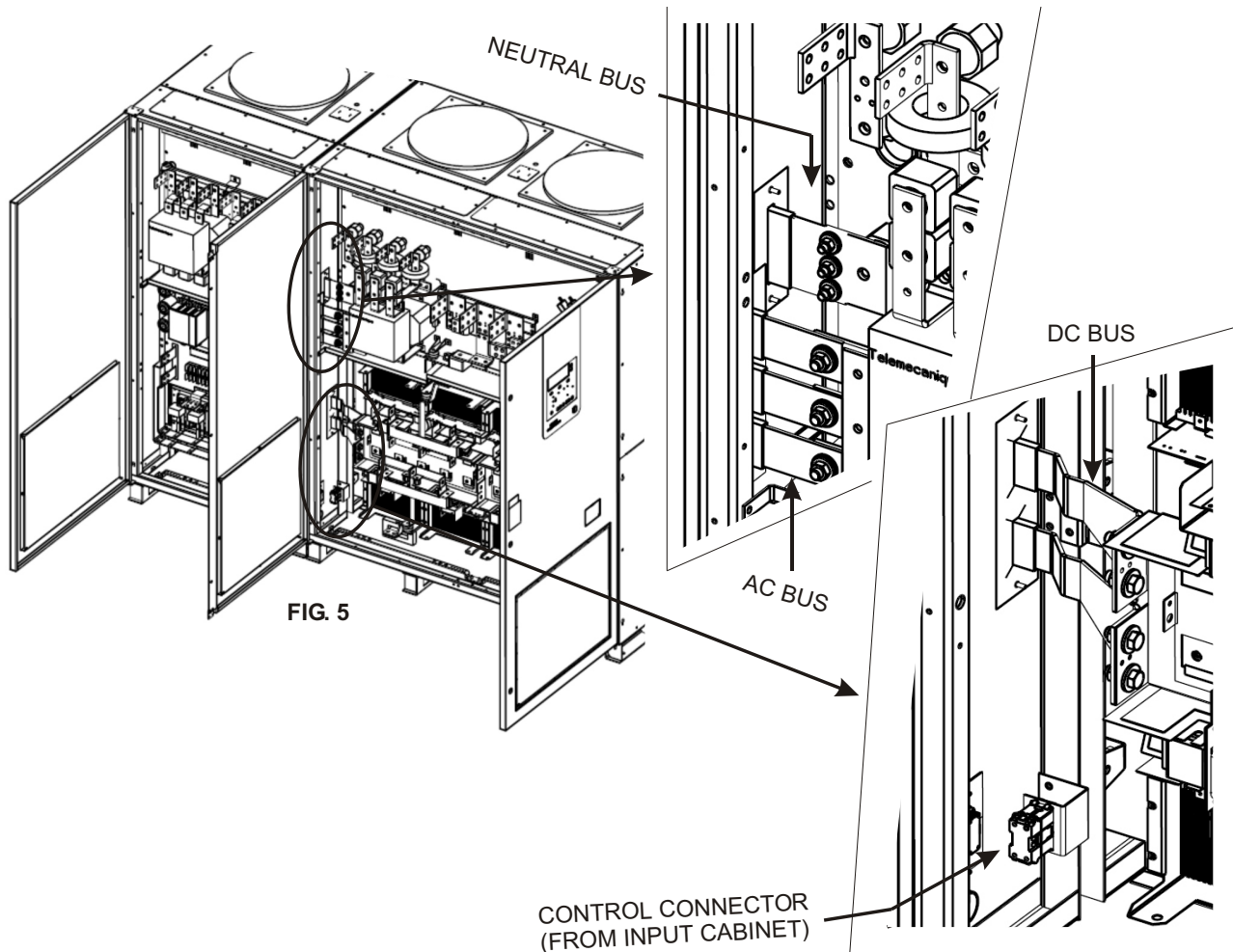

8. Connect the Control plug/connector (male) located in input cabinet to the mating connector (female) in the output cabinet thru conduit plate in the side panels. See FIG. 5 & FIG. 6.
9. Connect the Ground cable located in input cabinet to the Ground Bus located in the output cabinet thru the grommet hole in the side panels.

NOTE: SEE MANUAL PAGE 38 FOR CONNECTING POWER CABLES & ANCHORING THE CABINETS TO THE FLOOR. AFTER CONNECTING THE CABLES.

ENSURE NO LOOSE HARDWARE, METAL SHAVINGS, TOOLS, ETC. ARE LEFT BEHIND INSIDE THE CABINET.

CLOSE THE CABINETS FRONT AND BACK. RECOMMENDED TORQUE VALUES OF 3/8" STEEL BOLT IS 220 IN-LBS, 1/2" STEEL BOLT IS 390 IN-LBS.

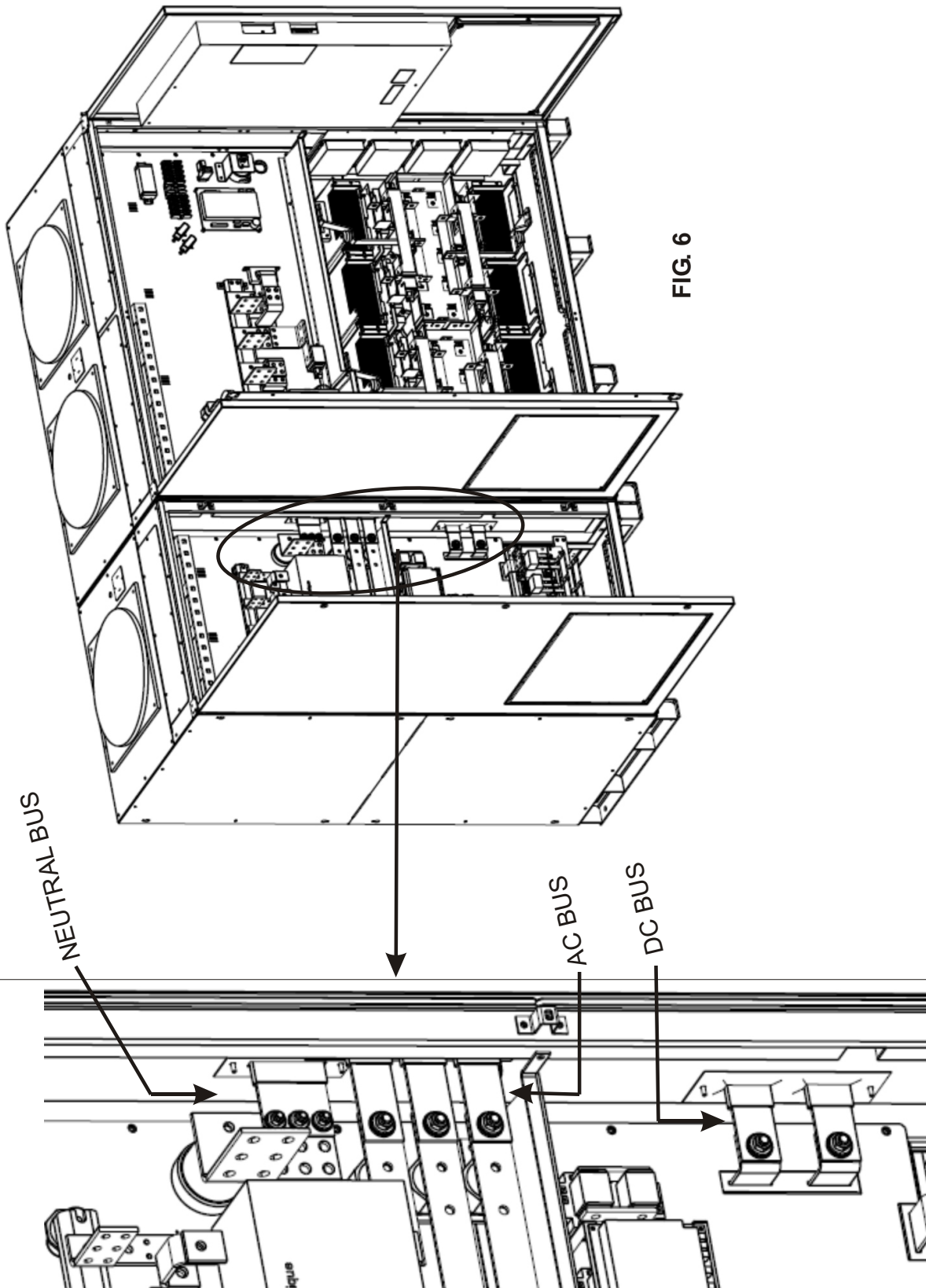

FIG. 6

TOSHIBA

Leading Innovation >>>

INDUSTRIAL DIVISION

13131 West Little Your road, Houston, Texas 77041

Tel (713) 466-0277 Fax (713) 466-8773

U.S. (877) 867-8773 Canada (800) 872-2192 Mexico 01/800/527-1204

www.toshiba.com/ind

Printed in the U.S.A.

Free Manuals Download Website

<http://myh66.com>

<http://usermanuals.us>

<http://www.somanuals.com>

<http://www.4manuals.cc>

<http://www.manual-lib.com>

<http://www.404manual.com>

<http://www.luxmanual.com>

<http://aubethermostatmanual.com>

Golf course search by state

<http://golfingnear.com>

Email search by domain

<http://emailbydomain.com>

Auto manuals search

<http://auto.somanuals.com>

TV manuals search

<http://tv.somanuals.com>