

SIREN MOUNTING:

1. Find a suitable spot to mount the siren in the engine compartment (firewall, sidewall, etc.).
2. Using siren bracket as a template, drill (2) 1/8" diameter holes in mounting surface.
Note: If mounting on the firewall, make certain there is no interference on the other side of the firewall.
3. Secure bracket using screws provided with kit.
4. Secure siren to the bracket using bolts and lock washers provided.

WARNING - Open end of siren must point downward to prevent water collection in horn end of siren.

WIRING:

RED WIRE - Splice to +12VDC battery source lead of existing alarm.

BLACK WIRE - Splice to chassis ground lead of existing alarm.

WHITE w/ BLACK STRIPE WIRE - Connect to the positive siren output from the alarm module.

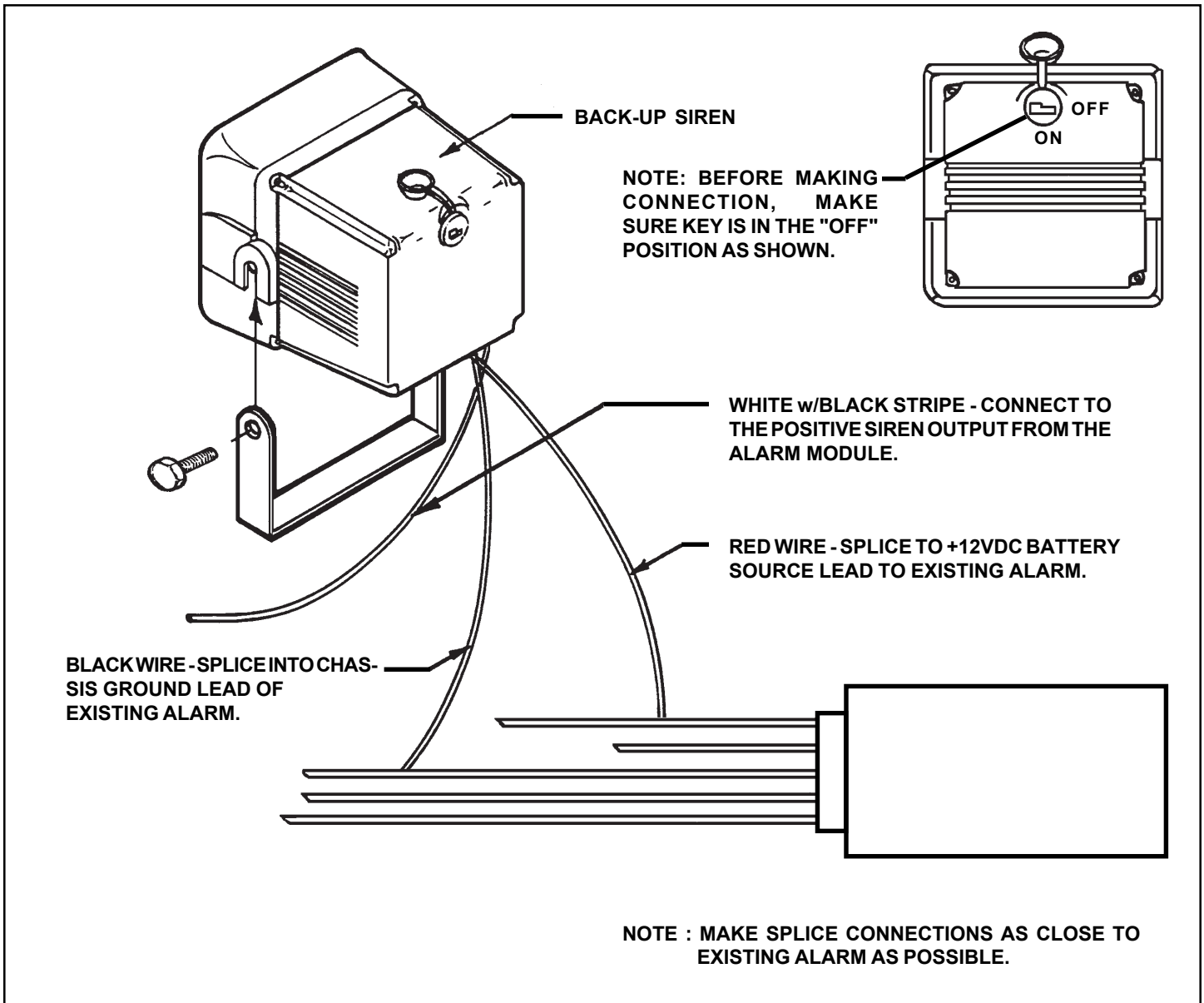

Free Manuals Download Website

<http://myh66.com>

<http://usermanuals.us>

<http://www.somanuals.com>

<http://www.4manuals.cc>

<http://www.manual-lib.com>

<http://www.404manual.com>

<http://www.luxmanual.com>

<http://aubethermostatmanual.com>

Golf course search by state

<http://golfingnear.com>

Email search by domain

<http://emailbydomain.com>

Auto manuals search

<http://auto.somanuals.com>

TV manuals search

<http://tv.somanuals.com>