

**RAMPAGE**  
BY AUDIOVOX™

**OWNER'S MANUAL  
MANUEL D'UTILISATION  
MANUAL DEL USUARIO**

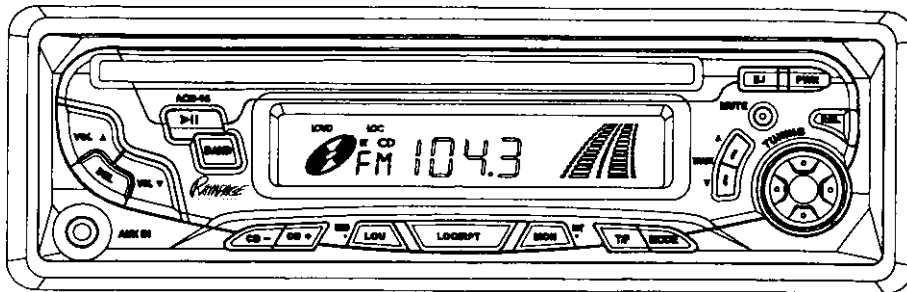

## **ACD-16**

**DETACHABLE FRONT PANEL, AM/FM/MPX RADIO WITH COMPACT DISC  
PLAYER, CD CHANGER CONTROLS  
AND QUARTZ CLOCK**

---

**AUTORADIO AM/FM/MPX AVEC FAÇADE AMOVIBLE, DOTÉ D'UN LECTEUR  
DE DISQUES COMPACTS, DE COMMANDES DE CHANGEUR DE CD ET D'UNE  
MONTRE À QUARTZ**

---

**PANEL DELANTERO DESMONTABLE CON  
RADIO AM/FM/MPX, CON REPRODUCTOR Y CAMBIADOR  
DE DISCOS COMPACTOS Y RELOJ DE CUARZO**

## INSTALLATION INSTRUCTIONS

This unit is designed for installation in cars, trucks, and vans with an existing radio opening. In many cases, a special installation kit will be required to mount the radio to the dashboard. These kits are available at electronics supply stores and car stereo specialist shops. Always check the kit application before purchasing to make sure the kit works with your vehicle. If you need a kit but cannot find it available, call our toll-free "HELP" line at **1-800-645-4994**.

### UNIVERSAL INSTALLATION PROCEDURE USING MOUNTING SLEEVE

1. Slide the mounting sleeve off of the chassis. If it is locked into position, use the removal tools (supplied) to disengage it.
2. Check the dashboard opening size by sliding the mounting sleeve into it. If the opening is not large enough, carefully cut or file as necessary until the sleeve easily slides into the opening. Do not force the sleeve into the opening or cause it to bend or bow. Check that there will be sufficient space behind the dashboard for the radio chassis.
3. Locate the series of bend tabs along the top, bottom, and sides of the mounting sleeve. With the sleeve fully inserted into the dashboard opening, bend as many of the tabs outward as necessary so that the sleeve is firmly secured to the dashboard.
4. Place the radio in front of the dashboard opening so that the wiring can be brought through the mounting sleeve. Follow the wiring diagram carefully and make certain all connections of the wiring harness are secure and insulated with wire nuts or electrical tape to insure proper operation of the unit. After completing the wiring connections, turn the unit on to confirm operation (ignition switch must be "on"). If unit does not operate, re-check all wiring until problem is corrected.

**NOTE:** Adjust AM antenna trimmer **NOW**. Refer to label on right side of chassis for adjustment instructions. Once proper operation is achieved, turn off the ignition switch and proceed with final mounting of the chassis.

5. Carefully slide the radio into the mounting sleeve making sure it is right-side-up until it is fully seated and the spring clips lock it into place.
6. Attach one end of the perforated support strap (supplied) to the screw stud on the rear of the chassis using the hex nut provided. Fasten the other end of the perforated strap to a secure part of the dashboard either above or below the radio using the screw provided. Bend the strap to position it as necessary.

**CAUTION:** The rear of the radio must be supported with the strap to prevent damage to the dashboard from the weight of the radio or improper operation due to vibration.

7. Test radio operation by referring to the Operating Instructions.

### INSTALLATION USING KITS

1. If your vehicle requires the use of an installation kit to mount this radio, follow the instructions included with the installation kit to attach the radio to the mounting plate supplied with the kit.
2. Wire and test the radio as described in Step 4 above.
3. Install the radio/mounting plate assembly to the sub-dashboard according to the instructions of the installation kit.
4. Attach the support strap to the radio and dashboard as described in Step 6 above.
5. Replace the dashboard trim panel.

### ISO INSTALLATION PROCEDURE

This unit has threaded holes in the chassis side panels which may be used with the original factory mounting brackets of some Toyota, Nissan, Mitsubishi, Isuzu, Hyundai and Honda vehicles to mount the radio to the dashboard. Please consult with your local car stereo specialist shop for assistance on this type of installation.

1. Remove the existing factory radio from its dashboard or center console mounting. Save all hardware and brackets as they will be used to mount the new radio.
2. Carefully un-snap the plastic frame from the front of the new radio chassis. Remove and discard the frame.
3. Remove the factory mounting brackets and hardware from the existing radio and attach them to the new radio.

**CAUTION:** DO NOT EXCEED M5 X 6 MM MAXIMUM SCREW SIZE.

LONGER SCREWS MAY TOUCH AND DAMAGE COMPONENTS INSIDE THE CHASSIS.

4. Wire the new radio to the vehicle as per step 4 above.
5. Mount the new radio assembly to the dashboard or center console using the reverse procedure of step 1.

## TOLL-FREE INSTALLATION ASSISTANCE

The installation and wiring connections for this unit are so simple, we doubt you'll need our help, but, if you do, we're here to help you. Just call our toll-free telephone assistance line at **1-800-645-4994** during the days and hours shown (U.S.A. and Canada only).

| DAY         | PACIFIC      | MOUNTAIN     | CENTRAL      | EASTERN      |
|-------------|--------------|--------------|--------------|--------------|
| MON. - FRI. | 5:30AM - 4PM | 6:30AM - 5PM | 7:30AM - 6PM | 8:30AM - 7PM |
| SATURDAY    | 6AM - 2PM    | 7AM - 3PM    | 8AM - 4PM    | 9AM - 5PM    |

### UNIVERSAL INSTALLATION USING MOUNTING SLEEVE

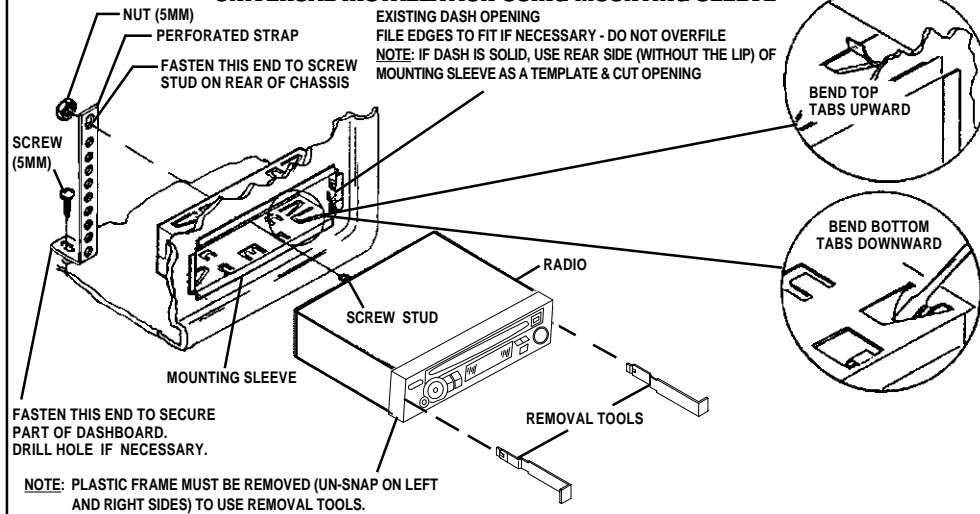

**CAUTION:**  
FOR PROPER OPERATION OF THE CD PLAYER, THE CHASSIS MUST BE MOUNTED WITHIN 20° OF HORIZONTAL. MAKE SURE THE UNIT IS MOUNTED WITHIN THIS LIMITATION.

SIDE VIEW OF CHASSIS

20° MAX.  
FRONT PANEL

### ISO INSTALLATION

REMOVE THE PLASTIC FRAME FROM THE FRONT OF THE CHASSIS BY CAREFULLY UN-SNAPPING IT.

UN-SNAP ON LEFT AND RIGHT SIDES  
PLASTIC FRAME

TYPICAL INSTALLATION

MAXIMUM SCREW SIZE M5 x 6  
FACTORY MOUNTING BRACKETS  
MAXIMUM SCREW SIZE M5 x 6

# RADIO WIRING

REFER TO PAGE 4 FOR SPEAKER WIRING

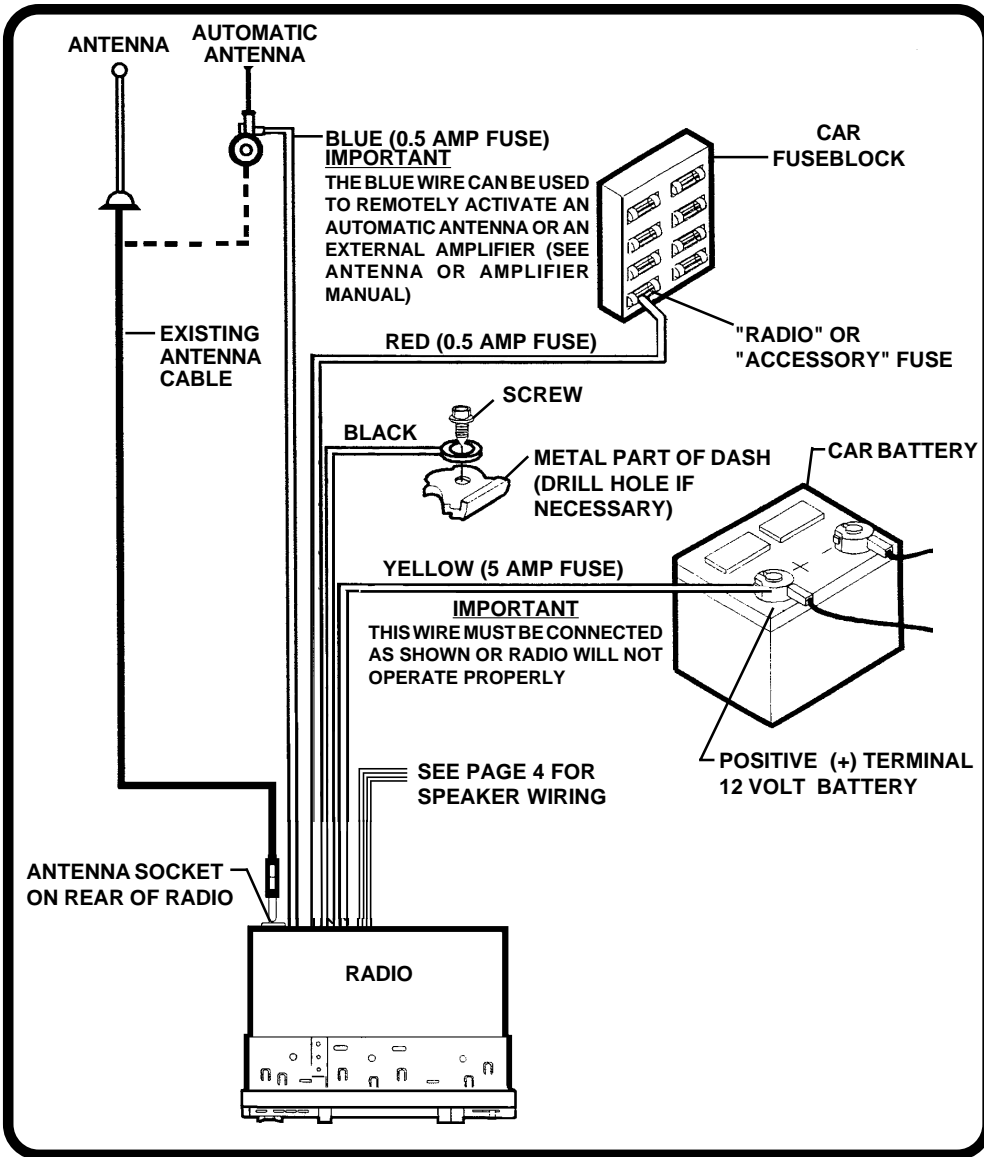

## SPEAKER WIRING

REFER TO PAGE 3  
FOR RADIO WIRING

### WARNING!

- THE AMPLIFIERS IN THIS RADIO ARE ONLY DESIGNED FOR USE WITH 4 SPEAKERS.
- **NEVER** COMBINE (BRIDGE) OUTPUTS FOR USE WITH 2 SPEAKERS.
- **NEVER** GROUND NEGATIVE SPEAKER LEADS TO CHASSIS GROUND.
- FAILURE TO WIRE EXACTLY AS SHOWN BELOW MAY CAUSE ELECTRICAL

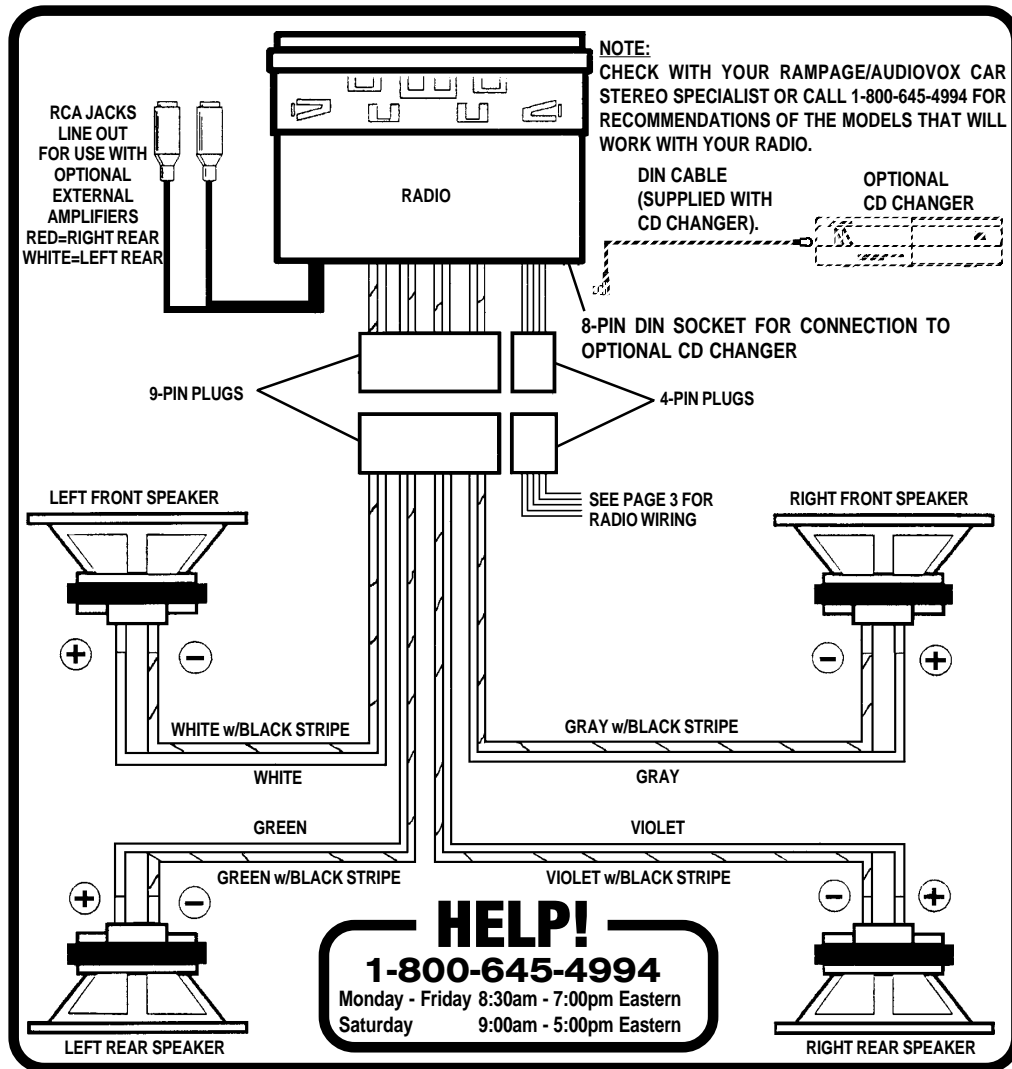

## OPERATING INSTRUCTIONS

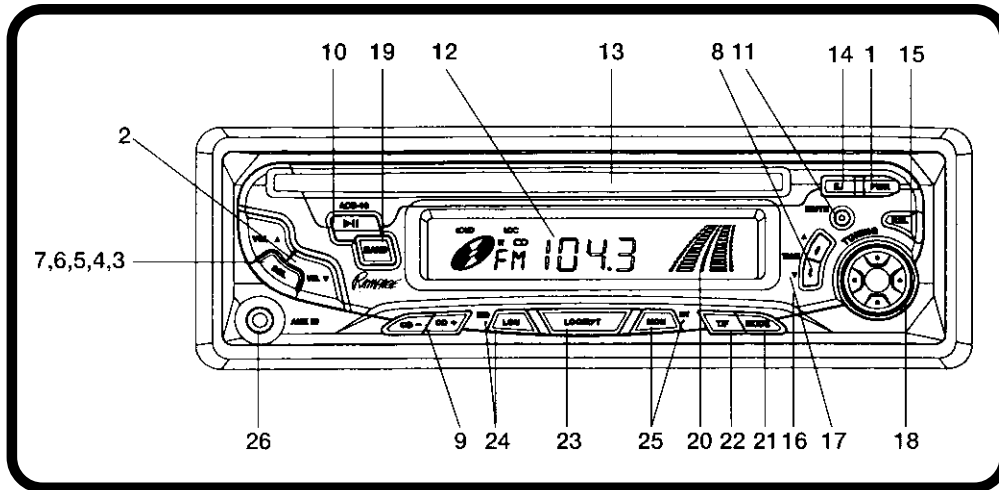

### ① ON-OFF POWER BUTTON (PWR)

Press this button to turn the unit on or off. The unit will also turn on automatically when a compact disc is inserted if the ignition switch is "on".

### ② VOLUME/LEVEL CONTROL (VOL ▲ / VOL ▼)

To increase the volume level, press the volume up side of the control. The volume will increase and the level will be shown on the display panel from a minimum of **VOL 0** to a maximum of **VOL 63**. To decrease the volume level, press the volume down side of the control. The display will automatically return to the normal indication 5 seconds after the last volume adjustment or when another function is activated. This control is also used in conjunction with the Select button ③ to adjust the bass, treble, balance and fader

levels as described in ④, ⑤, ⑥ and ⑦.

### ③ SELECT BUTTON (SEL)

This button is used to select the audio function (volume, bass, treble, balance, or fade) to be adjusted using the Level control ②. Pressing the Select button once will set the unit for volume adjustment. It is recommended that the volume level control ② be used. Pressing the Select button twice will set the unit for bass adjustment (**BAS** will appear on the display panel). Pressing the button additional times will select treble adjustment (**TRE** on the display), balance (**BAL**), or fader (**FAd**). The display will automatically return to the normal indication 5 seconds after the last adjustment or when another function is activated.

### ④ BASS CONTROL

To adjust the bass level, first select the

Bass mode by pressing the Select button ③ so the **BAS** indication appears on the display panel. Within 5 seconds of choosing the Bass mode, press the down side of the Level control ② to decrease the bass response or press the up side to increase it as desired. The level will be shown on the display panel from a minimum **BAS -7** to a maximum of **BAS 7** (**BAS 0** indicates flat response). The display will automatically return to the normal indication 5 seconds after the last adjustment or when another function is activated.

#### ⑤ TREBLE CONTROL

To adjust the treble level, first select the Treble mode by pressing the Select button ③ so the **TRE** indication appears on the display panel. Within 5 seconds of choosing the Treble mode, press the down side of the Level control ② to decrease the treble response or press the up side to increase it as desired. The level will be shown on the display panel from a minimum **TRE -7** to a maximum of **TRE 7** (**TRE 0** indicates flat response). The display will automatically return to the normal indication 5 seconds after the last adjustment or when another function is activated.

#### ⑥ LEFT/RIGHT BALANCE CONTROL

To adjust the left-right speaker balance, first select the Balance mode by pressing the Select button ③ so the **BAL** indication appears on the display panel. Within 5 seconds of choosing the Balance mode, press the down side of the Level control ② to adjust the stereo balance to the left channel speakers or press the up side to adjust it to the right channel speakers. The

balance position will be shown on the display panel from **BAL 10** (full left) to **BAL 0** (full right). When the volume level between the left and right speakers is equal, **BAL 0** will be shown on the display panel. The display will automatically return to the normal indication 5 seconds after the last adjustment or when another function is activated.

#### ⑦ FRONT/REAR FADER CONTROL

To adjust the front-rear speaker balance, first select the Fader mode by pressing the Select button ③ so the **FAd** indication appears on the display panel. Within 5 seconds of choosing the Fader mode, press the down side of the Level control ② to adjust the front-rear speaker balance to the rear speakers or press the up side to adjust it to the front speakers. The fader position will be shown on the display panel from **FAR 10** (full rear) to **FAF10** (full front). When the level between the front and rear speakers is equal, **FAd0** will be shown on the display panel. The display will automatically return to the normal indication 5 seconds after the last adjustment or when another function is activated.

#### ⑧ TRACK SELECT (TRACK ▲/ TRACK ▼)

The Track Select functions are used to quickly access the beginning of a particular track during CD player and CD changer operation. Each time the Forward Track Select (**TRACK ▲**) side of the button is pressed, the next higher track number will be selected as shown on the display panel. Similarly, each time the Backward Track Select (**TRACK ▼**) side of the button is

pressed, the next lower track number will be selected as shown on the display panel.

### ⑨ DISC SELECT ( CD- CD+)

During CD changer operation, this button is used to select the desired disc play. To advance to a higher number disc, press the **CD+** button. To decrement to a lower number disc, press the **CD-** button. The number of the disc in play will be shown on the display panel.

### ⑩ CD PLAY/PAUSE SELECTOR (▶||)

During CD player and CD changer operation, pressing this button will temporarily stop play of the disc (the  indication will flash on the display panel). Press the button again to resume play of the disc from the point at which it was stopped.

### ⑪ AUDIO MUTE SELECTOR (MUTE)

Press this button to mute the volume from the unit (**MUTE** will appear on the display panel). Pressing the button again or adjusting the Volume control ② will return to the volume level setting in use before the Mute function was activated.

### ⑫ LIQUID CRYSTAL DISPLAY PANEL

The Liquid Crystal Display (LCD) panel displays the frequency and activated functions.

**NOTE:** It is a characteristic of LCD panels that, if subjected to cold temperatures for an extended period of time, they may take longer to illuminate than under normal conditions. In addition, the visibility of the numbers on the LCD may slightly decrease.

The LCD read-out will return to normal when the temperature increases to a normal range.

### ⑬ DISC SLOT

With the label surface facing up, fully insert a compact disc into the slot until the soft-loading mechanism engages and pulls the disc in. The **LOADCd** indication will momentarily appear on the display panel followed by **CdP** and the playing time of the disc. Disc play will then begin with the track number and rotating disc play symbol () on the display panel.

**NOTE:** This unit is designed for play of standard 5" (12cm) Compact Discs ONLY. Do not attempt to use 3" (8cm) CD-Singles in this unit, either with or without an adapter, as damage to the player and/or disc can occur. Such damage will not be covered by the Warranty on this product.

### ⑭ DISC EJECT (EJ)

Disc play is stopped and the disc is ejected by pressing this button (**EJCD** will appear on the display panel). Remove the disc and insert another disc into the unit to begin play of the new disc or press the Function Mode Selector ④ to choose radio or CD changer mode operation. Discs will be ejected when the button is pressed and the ignition switch is on.

Radio or CD changer operation will automatically resume depending on which mode was in operation prior to disc play. If the disc is not removed from the unit within 10 seconds of being ejected, it will automatically be re-loaded into the unit to



prevent it from being accidentally damaged (☼ will appear on the display panel to indicate that a disc is loaded in the player). Play of the disc can be resumed by using the Function Mode Selector ⑳ to choose CD player function.

**NOTE:** To prevent an ejected disc from accidentally being damaged, always remove the disc from the unit. Do not leave the disc extending from the disc slot.

### ⑮ FRONT PANEL RELEASE BUTTON (REL)

This button is used to release the mechanism that holds the front panel to the chassis. To detach the front panel, press the button so that the panel releases from the chassis. Grasp the panel at the middle and pull it off of the chassis.

To re-attach the panel, press the left side of the panel in place first (left facing radio) and then press the right side of the panel until the mechanism locks it into place.

### NOTES ON USE OF FRONT PANEL

1. Make sure the front panel is right-side-up when attaching it to the chassis as it cannot be attached when up-side down.
2. Do not press very hard on the front panel when attaching it to the chassis. No more than light to moderate pressure should be needed.
3. When attaching the front panel, make sure it is centered in the chassis frame and is pressed straight into position.

4. When taking the front panel with you, please use the supplied carrying case to protect the panel from dirt and damage. Make sure there is no dust or dirt on the electrical terminals on the back of the panel as this could cause intermittent operation or other malfunctions.

### ⑯ THEFT-DETERRENT L.E.D.

Located on the chassis behind the front panel, a light-emitting diode (LED) will flash when the panel is removed. The flashing light serves as a visual warning to the would-be thief that the unit has been disabled by removal of the front panel.

### ⑰ RE-SET BUTTON

A Re-Set button is located on the front of the chassis (front panel must be removed to access the button). The re-set circuitry is provided to protect the microprocessor circuitry and should only be activated under the following circumstances as it will erase the time and pre-set memories.

1. Upon initial installation after all wiring is completed.
2. If there is a malfunction of any of the switches on the unit, pressing the Re-Set button may clear the system and return to normal operation.

### ⑱ MANUAL TUNING CONTROL

Turn this knob clockwise to tune upward in frequency on the band in use, counter-clockwise to tune downward in frequency. The frequency to which you are tuned will be shown in digital form on the display panel. When tuning in a station, always adjust

the control so that the correct broadcast frequency is shown on the display and adjust the control so that you are receiving a clear signal. If the radio is tuned off-frequency, you could experience distorted audio, noise and other reception problems.

#### ⑲ AM/FM BAND SELECTOR (BAND)

Each time this button is pressed, the radio band is changed. The indication **AM** or **FM** will appear on the display panel according to your selection.

#### ⑳ LEVEL METER

This display consists of two bar segments which indicate the level of the audio signal. The number of segments present in each bar corresponds to the audio signal level (more segments equals a stronger signal). During CD Player and CD Changer operation, the display provides an indication of the audio signal level present on the CD.

#### ㉑ FUNCTION SELECTOR (MODE)

This button is used to select the playback mode (radio, CD Player or optional CD Changer). With each press of the button, a different playback mode will be selected as indicated on the front panel display.

Radio (FM or AM on display) ⇨ CD Disc Player (CdP on display) ⇨ CD Changer (CdC on display).

During CD Player operation, the button may be used to change to radio or CD changer without ejecting the disc.

#### ㉒ TIME/FREQUENCY SELECTOR (T/F)

During operation, press this button to call the time display on the incorporated quartz

clock. The display will return to the radio frequency indication after 5 seconds.

During CD player and CD changer operation, the first press of the button will call the time display. In either case, the display will return to the disc indication after 5 seconds.

#### ㉓ LOCAL/REPEAT CONTROL (LOC/RPT)

During radio operation, pressing this button selects the local setting for the reception of strong signals. The **LOC** indication will appear on the display panel. Pressing the button again will deactivate the function. During CD Player and CD Changer operation, pressing the button will continuously repeat the current disc track. The **RPT** indication will appear in the display panel. Pressing the button again will deactivate this function.

#### ㉔ LOUD/RANDOM CONTROL (LOU/RND)

During radio or CD operation when listening to music at low volume levels this feature will boost bass and treble ranges to compensate for the characteristics of human hearing. Press the button momentarily to activate this feature and the indication **LOUD** will appear on the display panel. Pressing the button again momentarily will deactivate the feature (the **LOUD** indication will disappear from the display panel). During CD Player and CD Changer operation, pressing and holding this button for several seconds will cause the **CdP** and CD Changer to play disc tracks in random order. The indication **RND** will appear on the display panel. Pressing and holding the button again for several seconds will deactivate this function.

### ②⑤ MONORADIO PLAY/INTRODUCTION DISC PLAY (MON/INT)

During FM radio operation, this button is used to select mono or stereo reception of the broadcast signal. Under normal reception conditions, the unit should be left in the stereo mode as indicated by the **ST**Ⓞ indication on the display panel when tuned to an FM stereo signal. If the stereo signal is too noisy for comfortable listening, press the FM Mono/Stereo Selector button to switch to mono reception (the **ST**Ⓞ indication will disappear from the display panel). To return to stereo reception mode, press the button again so that the **ST**Ⓞ indication appears in the display panel.

During CD player or optional CD changer disc play, press this button to play the first

10 seconds of each track on the disc (**INT** will appear on the display panel). When a desired track is reached, press the button again to cancel the function (**INT** will disappear from the display panel) and play of the selected track will continue. Intro-Scan mode will also be canceled by activating the Repeat Play ②③ function.

### ②⑤ AUX IN CONNECTOR

The AUX IN connector provides the user option of applying an external source to the radio. The connector is compatible with most portable CD and cassette players or an MP3 digital audio playback unit. When the external source is connected, only that media is played by the radio; no other input sources (radio or CD) are operative.

---

**SETTING THE CLOCK**

---

Switch the vehicle ignition and radio "on".

Press the Time/Frequency button to call the time display.

Press and hold in the Time/Frequency Selector button ② with the time displayed. The time display will blink.

Press the VOL ▲ button to adjust the hours and **AM/PM** indication and VOL ▼ button to adjust the minutes to the correct time.

Five seconds after the last hour or minute adjustment is made, the time will be set in the unit and the display will return to the normal indication.

---

**CD PLAYER ERROR CODES**

---

**ER-1:** Indicates excessive temperature conditions at the CD changer. The error code will go off and play will resume when the temperature at the changer returns to a normal range.

**ER-2:** Indicates the disc is not loading or ejecting properly. Try re-loading or pressing the Eject button. Check the condition of the disc in use or try another disc.

**ER-3:** Not user serviceable, contact an approved warranty station near you for further assistance.

**ER-4:** Not user serviceable, contact an approved warranty station near you for further assistance.

**ER-5:** Not user serviceable, contact an approved warranty station near you for further assistance..

**ER-6:** Not user serviceable, contact an approved warranty station near you for further assistance..

**ER-7:** Not user serviceable, contact an approved warranty station near you for further assistance.

**ER-8:** Not user serviceable, contact an approved warranty station near you for further assistance.

**ER-9:** Eject the disc, make sure it is clean, undamaged and loaded correctly (label side up).

**ER-10:** Not user serviceable, contact an approved warranty station near you for further assistance.

**ER-11:** Indicates that there is no magazine loaded in the CD Changer.

---

**SPECIFICATIONS**

---

|                        |   |
|------------------------|---|
| Size:                  | 7" W x 2" H x 6-1/8" D<br>178 mm x 50 mm x 155 mm               |
| Operating Voltage:     | 12 volts DC, negative ground                                    |
| Fuse Ratings:          | Constant (yellow) lead: 5 AMP.<br>Switched (red) lead: 0.5 AMP. |
| Output Power:          | 60 watts maximum<br>(15 watts x 4 channels)                     |
| Output Wiring:         | Floating-ground type designed for 4 speaker use.                |
| Output Impedance:      | Compatible with 4-8 ohm speakers.                               |
| Tuning Range:          | AM: 530 – 1,720 KHz.<br>FM: 87.5 – 107.9 MHz.                   |
| Sensitivity:           | AM: 20 uv.<br>FM: 1.5 uv.                                       |
| FM Stereo Separation:  | >25 dB  |
| CD Frequency Response: | 20 – 20,000 Hz. $\pm 1$ dB                                      |
| CD Signal/Noise Ratio: | >60 dB  |
| CD Channel Separation: | >60 dB  |
| CD Distortion:         | 0.2%  |

\*Specifications are subject to change without notice.

## CARE AND MAINTENANCE

The radio section of your new sound system does not require any maintenance. We recommend that you keep this manual for reference on the many features found in this unit as well as how to set the clock.

The compact disc player section also requires no routine maintenance, but proper understanding of its use and handling will help you obtain maximum enjoyment of its capabilities. The following points should be observed:

- When cleaning the interior of the vehicle, do not get water or cleaning fluids on the unit.
- The CD player is a precision instrument and will not operate properly in extreme heat or cold. In case of such conditions, wait until the interior temperature of the vehicle reaches a normal temperature before using the player.
- If the temperature inside the player gets too hot, a protective circuit will automatically stop play of the disc. In this case, allow the unit to cool off before operating the player again.
- Never insert anything other than a 5" (12 cm) compact disc into the player as the mechanism can be damaged by foreign objects.
- Do not attempt to use 3" (8 cm) CD-Single discs in this unit, either with or without an adaptor, as damage to the player and/or disc may occur. Such damage will not be covered by the Warranty on this product.
- When not using the disc player, always remove the compact disc. Do not leave an ejected disc sitting in the disc slot as this can expose it to sunlight and other causes of damage.
- Do not attempt to open the unit chassis. There are no user serviceable parts or adjustments inside.
- When the vehicle warms up during cold weather or under damp conditions, moisture may condense on the lens of the disc player. Should this occur, the player will not operate properly until the moisture has evaporated.
- The unit is designed with a vibration dampening CD mechanism to minimize interruption of disc play due to normal vibration in a moving vehicle. When driving on very rough roads, however, occasional sound skips may occur. This will not scratch or damage the disc and normal play will resume when the rough conditions cease.

### HANDLING COMPACT DISCS

Dirt, dust, scratches, and warpage can cause skips in the playback and deterioration of sound quality. Please follow these guidelines to take care of your compact discs:



- Use only compact discs with the mark .
- Fingerprints, dust, and dirt should be carefully wiped off the disc's playing surface (shiny side) with a soft cloth. Wipe in a straight motion from the inside to the outside of the disc.
- Never use chemicals such as record sprays, household cleaners or thinner to clean compact discs. Such chemicals can irreparably damage the disc's surface.
- Discs should be kept in their storage cases when not in use.
- Do not expose discs to direct sunlight, high temperatures or high humidity for extended periods.
- Do not stick paper, tape, or labels on the disc surfaces nor write on them with any type of marker.

## 12 MONTH LIMITED WARRANTY

AUDIOVOX CORPORATION (the Company) warrants to the original retail purchaser of this product that should this product or any part thereof, under normal use and conditions, be proven defective in material or workmanship within 12 months from the date of original purchase, such defect(s) will be repaired or replaced with new or reconditioned product (at the Company's option) without charge for parts and repair labor.

To obtain repair or replacement within the terms of this Warranty, the product is to be delivered with proof of warranty coverage (e.g. dated bill of sale), specification of defect(s), transportation prepaid, to the warranty center at the address shown below.

This Warranty does not extend to the elimination of car static or motor noise, to correction of antenna problems, to costs incurred for installation, removal, or reinstallation of the product, or damage to tapes, compact discs, speakers, accessories, or vehicle electrical systems.

This Warranty does not apply to any product or part thereof which, in the opinion of the Company, has suffered or been damaged through alteration, improper installation, mishandling, misuse, neglect, accident, or by removal or defacement of the factory serial number/bar code label(s). THE EXTENT OF THE COMPANY'S LIABILITY UNDER THIS WARRANTY IS LIMITED TO THE REPAIR OR REPLACEMENT PROVIDED ABOVE AND, IN NO EVENT, SHALL THE COMPANY'S LIABILITY EXCEED THE PURCHASE PRICE PAID BY PURCHASER FOR THE PRODUCT.

This Warranty is in lieu of all other express warranties or liabilities. ANY IMPLIED WARRANTIES, INCLUDING ANY IMPLIED WARRANTY OF MERCHANTABILITY, SHALL BE LIMITED TO THE DURATION OF THIS WRITTEN WARRANTY. ANY ACTION FOR BREACH OF ANY WARRANTY HEREUNDER INCLUDING ANY IMPLIED WARRANTY OF MERCHANTABILITY MUST BE BROUGHT WITHIN A PERIOD OF 30 MONTHS FROM DATE OF ORIGINAL PURCHASE. IN NO CASE SHALL THE COMPANY BE LIABLE FOR ANY CONSEQUENTIAL OR INCIDENTAL DAMAGES FOR BREACH OF THIS OR ANY OTHER WARRANTY, EXPRESS OR IMPLIED, WHATSOEVER. No person or representative is authorized to assume for the Company any liability other than expressed herein in connection with the sale of this product.

Some states do not allow limitations on how long an implied warranty lasts or the exclusion or limitation of incidental or consequential damage so the above limitations or exclusions may not apply to you. This Warranty gives you specific legal rights and you may also have other rights which vary from state to state.

**U.S.A.:** AUDIOVOX CORPORATION, 150 MARCUS BLVD., HAUPPAUGE, NEW YORK 11788 • 1-800-645-4994

**CANADA:** CALL 1-800-645-4994 FOR LOCATION OF WARRANTY STATION SERVING YOUR AREA

Form No. 128-4270E





## Free Manuals Download Website

<http://myh66.com>

<http://usermanuals.us>

<http://www.somanuals.com>

<http://www.4manuals.cc>

<http://www.manual-lib.com>

<http://www.404manual.com>

<http://www.luxmanual.com>

<http://aubethermostatmanual.com>

Golf course search by state

<http://golfingnear.com>

Email search by domain

<http://emailbydomain.com>

Auto manuals search

<http://auto.somanuals.com>

TV manuals search

<http://tv.somanuals.com>