

uniden®

LRD 6599SWS Operating Guide

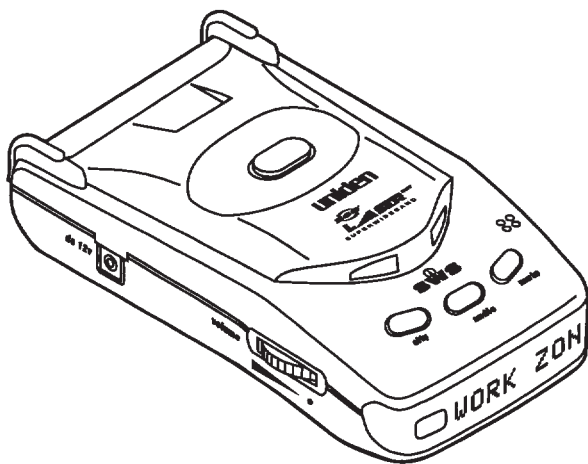

Precautions

Important: *The LRD 6599SWS was not designed to help you disobey the law. Safe drivers always obey the posted speed limit and legal driving methods at all times.*

Federal and Local Regulations

The FCC passed the Communications Act in 1934 to give all citizens the right to receive any type of radio transmission. The same radio frequencies used by police radar are also used by other devices, such as automatic door openers, burglar alarms, and some amateur radio equipment. Since the LRD 6599SWS is just a radio receiver tuned to a specific portion of the public radio spectrum, it is protected under this act.

Some local, state, and federal regulations may prohibit the use of this detection device. Please check with authorities regarding the use of this device before operating it.

Operation Notice Safety Warning Systems

You have purchased the newest technology designed for Radar, Laser and Safety Warning System detection and alert. You should be aware that Safety Warning transmitters (the device that alerts your detector for safety warning alerts) will be available for use throughout the United States. However, these transmitters may not be used in all areas.

While this detector is designed to warn you of road hazards, it is not designed as a substitute for safe, attentive driving procedures. Drivers are reminded to remain alert for road hazards at all times.

Contents

Introduction	1
Feature Highlights	1
Speed Detection Systems	2
Radar	2
Laser	3
Included with Your Radar Detector	4
Controls and Functions	5
LED Displays	7
Installation	9
Helpful Tips	9
Adjusting the Windshield Mounting Clip	10
Connecting the Power	11
Direct Connection	11
Using the Cigarette Lighter Adapter	12
Replacing the Fuse	13
Operation	14
Power On	14
Volume Control	14
Full Warning	15
The Safety Warning System	15
Memory Retention Feature	16
Audio/Dimmer Operation	16
Mute Operation	17
City/Highway Operation	18
LED Signal Strength Meter in City Mode	19
Care and Maintenance	20
Troubleshooting	21
Specifications	22
Replacement Parts	23
SWS Warning Messages	24
Highway Construction	24
Highway Hazard Zone Advisory	24
Weather Related Hazard	25
Travel Information Convenience	25
Fast/Slow Moving Vehicles	25

Features, Specifications, and availability of Optional Accessories are all subject to change without notice.

Uniden® is a registered trademark of Uniden America Corporation.

Introduction

Welcome to the world of sophisticated, early warning laser/radar detection. You have purchased one of the most advanced laser/radar detectors available. The LRD 6599SWS is a complete integrated laser/radar detector. It responds to the X-, K-, and Ka-SuperWideband radar guns in use today and also provides 360° detection of the latest speed monitoring system — the laser gun. And the built-in Safety Warning System (SWS™) is capable of detecting hazardous warning signals transmitted on the K-band.

When the SWS™ system is activated, a screen displays the appropriate message while the built-in digital voice technology announces the warning. The LRD 6599SWS provides distinct visual and audio alerts to warn you of the presence of X-, K-, and Ka-SuperWideband radar signals as well as IR laser signals.

The LRD 6599SWS employs Super Stalker Technology (SST), a state-of-the-art electronic system designed to make this radar detector invisible to all current VG-2 radar detector detectors. The LRD 6599SWS also uses the new D.R.O. (Dielectric Resonant Oscillator) and E.D.I.T. (Electronic Data Interference Terminator) circuitry, giving more reliable performance.

We are certain that you will enjoy the LRD 6599SWS, and to ensure that you get the most from its features, please read this Operating Guide carefully before installing and operating the unit.

Feature Highlights

- Safety Warning System™ with 8-digit message display
- Digital Voice Announcement
- VG-2 Undetectable
- Pulse Detection
- Signal Strength Meter
- City and Highway Modes
- Memory Retention Feature
- 360° Laser Detection
- Complete four-Band Coverage
- Super Wideband
- K/Ka Priority
- Audio/Dimmer Mode
- Auto Mute Mode
- Self Test

Speed Detection Systems

A speed detection device (often called a radar gun) sends out either a microwave signal or beam of light. When this signal reaches its target, part of the signal is reflected or bounced back toward the emitting gun. The time required for the signal to leave the gun, bounce off an object, and return is used to determine a vehicle's distance and speed.

Radar

Radar (**R**adio **D**etection and **R**anging) is a microwave system for detecting the speed of moving objects by reflected pulses of high frequency radio waves. There are three radar bands (microwave frequencies): X-band (10.49 to 10.56GHz), K-band (24.04 to 24.26 GHz), and the "SuperWide" Ka-band (33.4 GHz to 36 GHz).

The X-band was the first used for traffic, followed by the K-band which is harder to detect (most instant-on radar is K-band). The Ka-band was introduced in 1987, and widened to Ka-SuperWideband in 1990 by the FCC. The LRD 6599SWS monitors all current radar bands including the entire Ka-SuperWideband.

The radar beam is cone shaped — the narrower the beam, the greater the resolution. A moving vehicle reflects radar signals back towards the radar gun. The LRD 6599SWS can detect the signals emitted by radar guns, and it will sound an audio alarm and flash a warning indicator.

For continuously transmitting radar, use the LRD 6599SWS to get accurate detection from a safe distance. Weak signals cause the audio and visual alarms to sound intermittently, but as the signal gets stronger (the closer you get to the radar gun), both alarms increase in intensity.

Instant-on transmitters fire a short radar pulse beam at a vehicle and instantly read its speed. When detected at a distance, you will hear a few beeps and see the strength meter begin to light. Instant-On radar signals are the most difficult to detect at a safe distance because they are transmitted only when directed at you or at a vehicle directly ahead of you.

Laser

The Laser Speed Detection System, also called LIDAR (for **L**ight **D**etection and **R**anging), uses a laser gun that emits infrared light pulses just outside the spectrum of visible light. Each reflected pulse measures the speed of the object coming toward, or going away from, the laser gun.

Unlike radar, the laser gun emits a very narrow beam of light, so it can pinpoint a speeding car within traffic. The infrared beam spreads out, but slowly and over a longer distance than a radar signal.

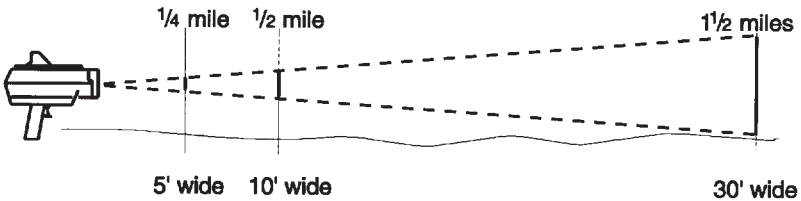

The laser gun can acquire a speed reading as quickly as 0.3 seconds, sometimes less. However, since it isn't easy to accurately aim at and hit a moving target, an operator often moves the laser gun in several directions to get a reading. So laser signals are emitted continuously for a few seconds for each speed measurement. The LRD 6599SWS can detect these light pulses from as far away as 1.5 miles, which is about four times the effective range of a laser gun (2,000 feet), and about ten times its average operating range (500-800 feet).

Note: *To be safe, do not ignore any warnings. Although there are other types of radar signals that may cause interference, when the LRD 6599SWS detects a signal, be on the alert. It is important to exercise caution at all times.*

Included with Your Radar Detector



Owner's Guide

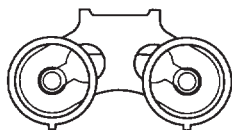

Windshield Mounting
Clip



Printed Material

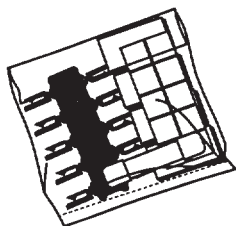

Fuses and Spare Parts

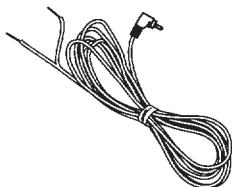

Straight Power Cord

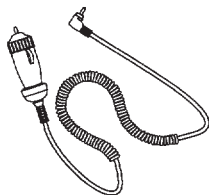

Coiled Cigarette
Adapter

If any of these items are missing or damaged, contact your dealer immediately. Be sure to complete and mail the Product Registration Card.

Controls and Functions

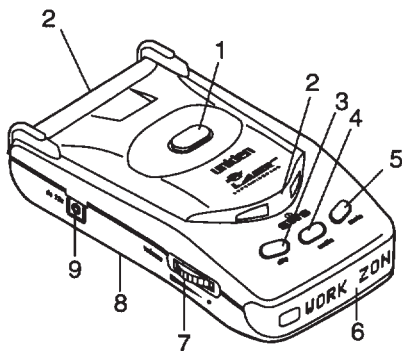

1. **Clip Release** — Press the clip release button to remove the LRD 6599SWS from the windshield mounting clip.
2. **Rear, Side, and Front Laser Detector Lenses** — For rear, side, and front detection of laser signals.
3. **CITY Button** — With each press, the mode toggles from Highway to City mode. The CITY button helps reduce X-band false alarms while driving in the city. Select HIGHWAY for long range detection. Depending on the mode selected, either CTY or HWY will display in the LED Display.
4. **AUDIO Button** — With each press, the mode toggles from DIMMER (LEDs dim only), to AUDIO (turns off LED display except mode indication and dims the Three-Color LED), to NORMAL (LED display and audio on).
5. **MUTE Button** — Press the MUTE button to activate the Auto Mute feature, which produces a full alert tone when a signal is first received, then automatically reduces to half volume. If activated in City mode, an alert sounds briefly, followed by a Mute tone (see page 19).
6. **LED Display** — LEDs display LASER/RADAR alerts, signal strength, operation mode, and Safety Warning System (SWS) messages.

7. On-Off/Volume Control — Turns the power on (with a click) and adjusts the Audio alert volume.
8. Speaker — Sounds voice prompts/messages and audio alerts. There are different announcements/alert tones which distinguish each type of signal received. When you become familiar with all the distinct alert signals, you can operate the LRD 6599SWS just by listening, devoting your full attention to driving.
9. 12V DC Power Input — Connect the DC power cord here.

Note: Use on a Uniden® supplied power cord or its replacement.

LED Displays

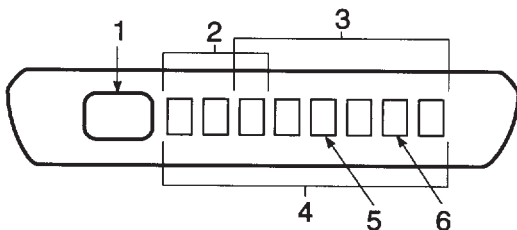

1. **Three-Color LED** — Red indicates a radar detection; Green indicates a laser detection; and Amber indicates a Safety Warning System(SWS) message.
2. **Band and City/Highway Mode** — The first three LEDs indicate X-, K-, Ka-SuperWideband radar signal, and City or Highway mode. If a laser signal is detected, LASER will display in the first five LEDs while the remaining LEDs light. A distinct audio alert is heard for radar and laser signals.
3. **LED Signal Strength Meter** — Starting with the third LED position, as the signal gets stronger, additional LEDs will light. See page 19, LED Signal Strength Meter in City Mode.
4. **Safety Warning System (SWS) Display** — All eight LEDs display SWS messages. Messages longer than eight-digits are scrolled repeatedly. When SWS data is received and cannot be specified, 'SAFETY WARNING MESSAGE' displays. A distinct audio alert is heard for SWS messages.
5. **Dimmer/Audio Mode** — The fifth LED position indicates Dimmer (D) or Audio (A) mode. Dimmer mode dims the LEDs but displays all possible data. Audio mode disables signal displays and dims the Three-Color LED.
6. **Mute Mode** — The seventh LED position indicates Mute (M) mode. Signals received sound for a few seconds then are reduced to half the normal tone (Mute tone).

When a Ka-band is received with a signal strength of 4:



Red

When City, Audio, and Mute modes are turned on:



When a SWS message 'ROAD CLOSED AHEAD' is received:



Amber

1. The first eight characters display for about two seconds.
2. The message scrolls to the left at the rate of approximately three characters each second.
3. Scrolling stops at the end of the message and the display turns off for one second.
4. The message displays again and repeats scrolling.

Note: Every time you turn on the LRD 6599SWS, a self-test is performed for all LEDs and Alert tones. You will hear in-order five distinct tones for the X-, K-, and Ka-SuperWideband radar bands, Laser, as well as for SWS.

Installation

The LRD 6599SWS uses a highly sensitive horn-type antenna and IR laser sensor to receive radar/laser signals. Its sensitivity and range depend on the method of installation and the direction of the antenna/sensor in relation to the signal source. The inherent nature of radar waves makes them reflect off metallic surfaces. This is why these waves are so useful for measuring the speed of a vehicle. The IR laser light may reflect only from shiny surfaces. Both radar waves and IR laser light will, however, pass through plastic or glass.

Before you decide where to put your radar detector, please keep in mind these two important factors:

- For safety, do not mount the LRD 6599SWS in a location where it will obstruct your driving vision.
- Most vehicles have the top part of the windshield tinted. Mounting the LRD 6599SWS behind tinted or mirrored glass may reduce the effectiveness of laser detection by reducing the amount of laser light received by the Detector.

Helpful Tips

The antenna and the forward looking sensor are located behind the rear panel of the unit, (and the rear- and side-looking sensors are located on top of the unit), directly behind the mode selection keys. The antenna and sensors should not be obstructed by metal or metallic surfaces and should be pointed at the horizon for accurate long-range detection.



- Do not mount the unit behind the windshield wiper blades, radio antenna, tinted glass area, or mirrored glass. Be sure the unit is free from obstruction by seat backs, rear view mirror, sun visors, or the ceiling of the automobile.
- Do not mount the unit in front of the heater or defroster vents.
- Do not leave the unit in direct sunlight or in the glove compartment of a closed car for long periods of time, as extreme changes in temperature may cause internal damage. Also, removing the unit from the windshield makes you less susceptible to break-in and theft.

Adjusting the Windshield Mounting Clip

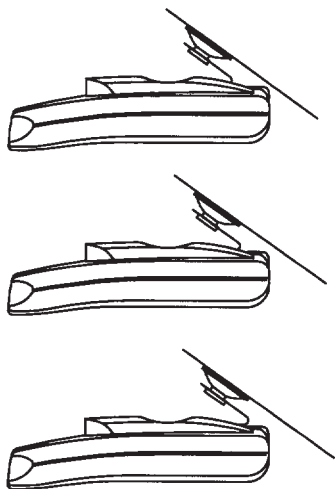

1. The metal portion of the bracket locks into the plastic portion at three different positions. These positions can be used for vehicles with different vertical windshield angles. The back position can be used for vehicles with windshields that are slanted back.
2. For optimum laser detection, bend the angled portion of the windshield mounting bracket so that the LRD 6599SWS is parallel to the road surface. Be sure the LRD 6599SWS is mounted so it is free of obstructions from seat backs, rear view mirror, sun visors, or the ceiling of the automobile. There must be a clear 360° line of sight to the outside of the vehicle.

To mount the LRD 6599SWS:

1. Insert the windshield clip into the LRD 6599SWS.
2. Place the bracket and the LRD 6599SWS in the proper location on the windshield of your vehicle, and press the suction cups firmly against the windshield.

Connecting the Power

Direct Connection

Warning: *The LRD 6599SWS is designed to operate only with 12V DC, negative ground power systems. Operation of the unit on other voltages or polarities will cause damage to the unit and may create a fire hazard.*

The straight power cord provided with the unit has bare wires at one end, and a small connector at the other end.

1. Connect the positive wire to a 12V DC source in your vehicle's fuse box.
2. Connect the other wire to ground.
3. Run the power cord from the fuse box to the LRD 6599SWS.

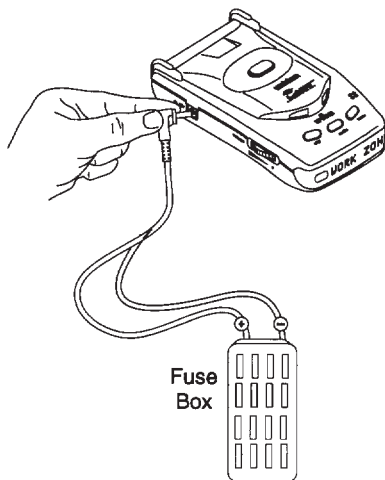

Note: *Ensure the cord does not interfere with vehicle operation or cause a tripping hazard.*

4. Plug the power cord connector into your radar detector at the jack labeled "DC 12V."

Using the Cigarette Lighter Adapter

Another power cord provided with the unit has a cigarette lighter socket plug at one end and a small connector at the other.

1. Insert the small connector into the jack on the side of the unit.

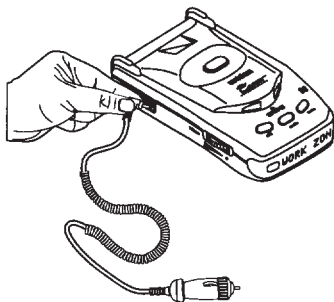

2. Insert the other end into the cigarette lighter socket of your vehicle.

When installing the power cord, make sure that:

- The socket is clean to allow proper contact.
- The power cord does not block the antenna area on the back of the unit.

Your unit also comes with ten power cord mounting clips. You can use these clips to attach the power cord to the window frame or other parts of the vehicle, keeping it neat and out of the way. Use the double-sided foam tape squares to attach each clip. Slip the power cord into the clip to hold it securely in place.

Replacing the Fuse

The cigarette lighter plug contains a 1-ampere fuse to protect it from power surges.

1. To replace the fuse, unscrew the top of the plug.

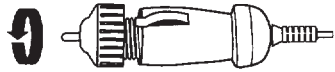

2. Remove the fuse and replace it with the same type.

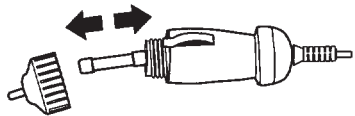

3. To replace the top, push in the two metal contacts and twist into place.

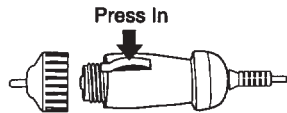

Note: Your LRD 6599SWS comes with an extra fuse.

Operation

You are now ready to enjoy the convenience and security of your LRD 6599SWS. Please read this section of the Operating Guide carefully to familiarize yourself with the basic operation of this unit.

Power On

Turn the Volume Control switch to turn power on. Once the Power-On alert sounds, your LRD 6599SWS performs a six second self-test of all circuits. The X-band alert sounds for two seconds while the Three-Color LED illuminates red, and the Signal Meter LED lights. Next you will hear the K-band, Ka-Super Wideband, Laser, and SWS alerts for one second each. (The corresponding Three-Color LED, City/Highway, Audio/Dimmer, and Mute indications also light.)

After the self-test, your detector sets the modes which were used last. If this is the first time you have used your LRD 6599SWS, it should be set for HWY use, and both the AUDIO and MUTE modes should be off.

If you experience any of these problems:

- Settings do not display
- The unit turns on and off intermittently
- An alert sounds too often for no reason

Check to make sure both ends of the power cord are tightly secured. If the problems continue, refer to page 21, "Troubleshooting" for more information.

Volume Control

Adjust the Volume to a comfortable announcement/ alarm tone level for your vehicle. The volume level does not have any effect on the unit's sensitivity.

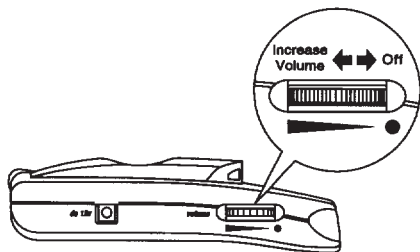

Full Warning

When the LRD 6599SWS detects a radar, laser, or safety warning signal, it emits a distinct warning tone and digital voice announcement. The corresponding X-, K-, Ka-Super Wideband, Laser, or SWS indication display along with the corresponding red, green or amber Three-Color LED. For radar, as the signal gets stronger, more signal strength LEDs light.

Note: *The alert tones for the radar, laser, and SWS are all different.*

The Safety Warning System

The Uniden Safety Warning System™ (SWS) is a new communication system which will provide you with an early warning message when a road hazard exists. The LRD 6599SWS is capable of detecting SWS signal broadcasts on the K-band by either law enforcement or local departments of transportation.

You will receive several indications when an SWS warning is received. The three-color LED on the left part of the display turns amber, an alert sounds, and a message appears on the 8-digit screen. Additionally, with the new digital voice technology, your LRD 6599SWS announces the warning message at the beginning of each alert, so you won't have to take your eyes off the road.

Since some warning messages exceed the screen's display length, your detector is designed to scroll messages with more than 8 characters. Also, during an alert, certain conditions can cause warning indications to be different from those you'll usually get. These special indications are listed below:

- If your detector receives a message but cannot determine its content, the message "SAFETY WARNING MESSAGE" is displayed while "*Incoming safety warning message*" is announced.
- Similarly, if an incomplete message is received or if the signal is interrupted during an alert, the 8-character display begins to flash. The display stops flashing once the full message is received or the SWS signal is reacquired.

Important: Your unit only displays safety warning messages when it receives signals from an active Safety Warning System transmitter.

Memory Retention Feature

The Memory Retention Feature retains the LRD 6599SWS's operational settings in memory for at least two days without power. When you turn on the LRD 6599SWS, it will be in the same mode as when you turned it off.

Audio/Dimmer Operation

Press the AUDIO button to select one of the following modes:

- DIMMER mode – dims your detector's display. A "D" is displayed to indicate this mode, and "Display Dim" is announced.
- AUDIO mode – turns your detector's display off. An "A" is displayed to indicate this mode, and "Audio Only" is announced. (The mode indications (CITY, AUDIO, or MUTE) remain on.)

Note: *Do not set the Volume control at minimum while in this mode because you'll disable both alert types—visual and audio.*

- NORMAL mode – is the normal display mode. When returning to this mode, "Display on" is announced.

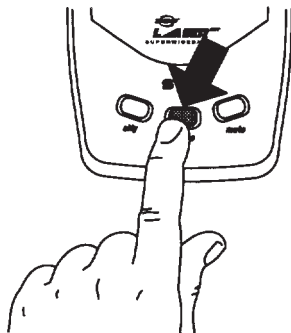

Memory Retention Feature

The Memory Retention Feature retains the LRD 6599SWS's operational settings in memory for at least two days without power. When you turn on the LRD 6599SWS, it will be in the same mode as when you turned it off.

Audio/Dimmer Operation

Press the AUDIO button to select one of the following modes:

- DIMMER mode – dims your detector's display. A "D" is displayed to indicate this mode, and "Display Dim" is announced.
- AUDIO mode – turns your detector's display off. An "A" is displayed to indicate this mode, and "Audio Only" is announced. (The mode indications (CITY, AUDIO, or MUTE) remain on.)

Note: *Do not set the Volume control at minimum while in this mode because you'll disable both alert types—visual and audio.*

- NORMAL mode – is the normal display mode. When returning to this mode, "Display on" is announced.

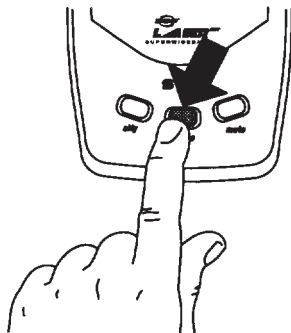

City/Highway Operation

In highly populated areas, you may encounter many devices that use the same frequencies as radar signals, such as motion detectors, automatic doors, and intrusion alarms. These devices may trigger an effect called “falsing.”

Press the CITY button to change between Highway or City mode:

- CITY mode – filters most of the weaker radar signals and significantly reduces “falsing.” In this mode, the combination of visual and audio alert tones varies based on the strength of the signal received. “CITY” is displayed to indicate this mode, and “City mode” is announced.
- HIGHWAY mode – has a lower signal threshold, which simply means it doesn’t filter out weaker signals. Your detector will be more sensitive to distant signals, but it also is more likely to “false.” Since radar use declines significantly outside heavily populated areas, this mode provides better long range detection while traveling long distances. “HWY” is displayed to indicate this mode, and “Highway mode” is announced.

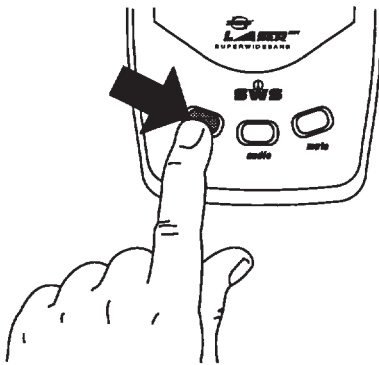

Note: *If you use both Mute mode and City modes, you won’t receive an alert until you are very close to the radar source.*

LED Signal Strength Meter in City Mode

The LED signal strength meter gives you instant information about the strength of the signal being detected. A weak signal causes the first LED to light, but as signal strength increases, additional LEDs light. All LEDs light when a full-strength signal is received. Use this meter to judge the distance from the signal source.

Signal Strength	X-, K-, and Ka-Super WideBand	Laser*
●○○○○○	Visual	Audio
●●○○○○	Visual	Audio
●●●○○○	Visual/Audio	Audio
●●●●○○	Visual/Audio	Audio
●●●●●○	Visual/Audio	Audio
●●●●●●	Visual/Audio	Audio

**Note: Signal Strength for the Laser level is not displayed, only 'LASER' displays in the LED screen with an alert.*

Radar Voice Announcement

Your LRD 6599SWS will always let you know what it's detected. When an alert begins, the digital voice announcement corresponds to the radar signal being detected. The announcements are listed below:

- "X band"
- "K band"
- "KA band"
- "Laser band"

Care and Maintenance

The LRD 6599SWS is designed to give you years of trouble-free service. There are no user-serviceable parts inside, and, except for the fuse, no maintenance is required. To keep your detector in new condition, follow these important suggestions:

- Never leave the LRD 6599SWS on the windshield when you park your vehicle. The temperature in the vehicle in summer can reach levels above what is considered safe for this unit.
- To make you less susceptible to break-in and theft, remove the unit from your windshield when you leave your vehicle.
- Do not expose the unit to moisture. Rain, dew, road splash, or other liquids can damage the internal components and reduce sensitivity of the LRD 6599SWS.

Troubleshooting

If your LRD 6599SWS does not perform up to expectations, try the suggestions listed below. If you cannot get satisfactory results, call the Uniden Customer Service Center at (800) 297-1023, 8:00 a.m. to 5:00 p.m. Central Time, Monday through Friday.

Unit does not operate:	<ul style="list-style-type: none"> • Check the power cord. Be sure the connectors are properly installed. • Be sure ignition key is ON or in the accessory position. • Fuse out. Check and replace. • Check power to lighter socket. • Vehicle electrical problem exists. • Make sure that the volume control is in the ON position. • Clean cigarette lighter socket.
Unit fails the self test.	<ul style="list-style-type: none"> • Call Uniden Customer Service Center, (800) 297-1023.
Weak detection.	<ul style="list-style-type: none"> • Check angle of unit. Point to the horizon. • Antenna/Sensor is obstructed. Relocate the unit clear of any obstruction outside the windshield, such as a wiper blade. • Relocate the unit clear of the window tint.
Inaccurate or erratic detection:	<ul style="list-style-type: none"> • Loose power cord. Check both connectors. • Power cord is broken. Check and replace.
Beeps over bumps or rough road.	<ul style="list-style-type: none"> • Check that the power cord is connected at both ends. • Clean cigarette lighter socket.
Beeps at same location.	<ul style="list-style-type: none"> • Falsing because you have passed a motion sensor or alarm.
Signal strength meter registers, but no audio.	<ul style="list-style-type: none"> • For highway use, make sure the Highway mode is ON. • Increase the volume.
The unit bounces against the windshield.	<ul style="list-style-type: none"> • Reposition so that the bumpers are firmly against the windshield.

Specifications

General

Dimensions:	3 1/9 in.(W) x 4 5/8 in.(D) x 5/6 in.(H)
Weight:	3.5 oz.
Power Requirements:	13.8 VDC
Temperature Range:	Operating: -5°F to 160°F (-20°C to 70°C) Storage: -40°F to 185°F (-40°C to 85°C)

360° Laser Detector

Receiver Type:	Pulse Laser Signal Receiver
Sensor Front End:	Convex Condenser Lens
Detector Type:	Pulse Width Discriminator
Receiver Bandwidth:	30 MHz
Spectral Response:	800 - 1100 nm
Alert Hold Time:	3 seconds

Radar Detector

Receiver Type:	Double Conversion Superheterodyne Self-Contained Antenna
Detector Type:	Scanning Frequency Discriminator
Antenna Type:	Linear polarized, E vector vertical
Sensitivity:	X-band = -114 dBm/cm ² K-band = -104 dBm/cm ² Ka-SuperWideband = -100 dBm/cm ²
Frequency of Operation:	10.490 - 10.560 GHz (X-band) 24.040 - 24.260 GHz (K-band) 33.40 - 36.00 GHz (Ka-SuperWideband)

Specifications are subject to change without notice.

Replacement Parts



Owner's
Guide

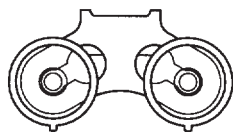

Windshield Mounting
Clip



Printed Material

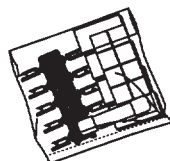

Fuses and
Spare Parts

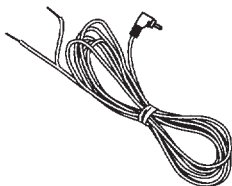

Straight Power Cord



Coiled Cigarette
Adapter

SWS Warning Messages

Highway Construction

WORK ZONE AHEAD
ROAD CLOSED AHEAD / FOLLOW DETOUR
BRIDGE CLOSED AHEAD / FOLLOW DETOUR
HIGHWAY WORK CREWS AHEAD
UTILITY WORK CREWS AHEAD
ALL TRAFFIC FOLLOW DETOUR AHEAD
ALL TRUCKS FOLLOW DETOUR AHEAD
ALL TRAFFIC EXIT AHEAD
RIGHT LANE CLOSED AHEAD
CENTER LANE CLOSED AHEAD
LEFT LANE CLOSED AHEAD

Highway Hazard Zone Advisory

TRAIN APPROACHING / AT CROSSING
LOW OVERPASS AHEAD
DRAWBRIDGE UP
OBSERVE BRIDGE WEIGHT LIMIT
ROCK SLIDE AREA AHEAD
SCHOOL ZONE AHEAD
ROAD NARROWS AHEAD
SHARP CURVE AHEAD
PEDESTRIAN CROSSING AHEAD
DEER / MOOSE CROSSING
BLIND / DEAF CHILD AREA
STEEP GRADE AHEAD / TRUCK USE LOW GEAR
ACCIDENT AHEAD
POOR ROAD SURFACE AHEAD
SCHOOL BUS LOADING / UNLOADING
NO PASSING ZONE
DANGEROUS INTERSECTION AHEAD
STATIONARY EMERGENCY VEHICLE AHEAD

Weather Related Hazard

HIGH WIND AHEAD
SEVERE WEATHER AHEAD
HEAVY FOG AHEAD
HIGH WATER / FLOODING AHEAD
ICE ON BRIDGE AHEAD
ICE ON ROAD AHEAD
BLOWING DUST AHEAD
BLOWING SAND AHEAD
BLOWING SNOW AHEAD
BLOWING SNOW WHITE AREA AHEAD

Travel Information Convenience

REST AREA AHEAD
REST AREA WITH SERVICE AHEAD
24 HOUR FUEL SERVICE AHEAD
INSPECTION STATION OPEN
INSPECTION STATION CLOSED
REDUCED SPEED AREA AHEAD
SPEED LIMIT ENFORCED
HAZARDOUS MATERIALS EXIT AHEAD
CONGESTION AHEAD / EXPECT DELAY
EXPECT 10 MINUTE DELAY
EXPECT 20 MINUTE DELAY
EXPECT 30 MINUTE DELAY
EXPECT 1 HOUR DELAY
TRAFFIC ALERT / TUNE AM RADIO
PAY TOLL AHEAD
TRUCKS EXIT RIGHT
TRUCKS EXIT LEFT

Fast/Slow Moving Vehicles

EMERGENCY VEHICLE IN TRANSIT
POLICE IN PURSUIT
OVERSIZE VEHICLE IN TRANSIT
SLOW MOVING VEHICLE

One Year Limited Warranty

Important: Evidence of original purchase is required for warranty service.

WARRANTOR: UNIDEN AMERICA CORPORATION (“Uniden”)

ELEMENTS OF WARRANTY: Uniden warrants, for one year, to the original retail owner, this Uniden Product to be free from defects in materials and craftsmanship with only the limitations or exclusions set out below.

WARRANTY DURATION: This warranty to the original user shall terminate and be of no further effect 12 months after the date of original retail sale. The warranty is invalid if the Product is (A) damaged or not maintained as reasonable or necessary, (B) modified, altered, or used as part of any conversion kits, subassemblies, or any configurations not sold by Uniden, (C) improperly installed, (D) serviced or repaired by someone other than an authorized Uniden service center for a defect or malfunction covered by this warranty, (E) used in any conjunction with equipment or parts or as part of any system not manufactured by Uniden, or (F) installed or programmed by anyone other than as detailed by the Operating Guide for this product.

STATEMENT OF REMEDY: In the event that the product does not conform to this warranty at any time while this warranty is in effect, warrantor will repair the defect and return it to you without charge for parts, service, or any other cost (except shipping and handling) incurred by warrantor or its representatives in connection with the performance of this warranty. **THE LIMITED WARRANTY SET FORTH ABOVE IS THE SOLE AND ENTIRE WARRANTY PERTAINING TO THE PRODUCT AND IS IN LIEU OF AND EXCLUDES ALL OTHER WARRANTIES OF ANY NATURE WHATSOEVER, WHETHER EXPRESS, IMPLIED OR ARISING BY OPERATION OF LAW, INCLUDING, BUT NOT LIMITED TO ANY IMPLIED WARRANTIES OF MERCHANTABILITY OR FITNESS FOR A PARTICULAR PURPOSE. THIS WARRANTY DOES NOT COVER OR PROVIDE FOR THE REIMBURSEMENT OR PAYMENT OF INCIDENTAL OR CONSEQUENTIAL DAMAGES.** Some states do not allow this exclusion or limitation of incidental or consequential damages so the above limitation or exclusion may not apply to you.

LEGAL REMEDIES: This warranty gives you specific legal rights, and you may also have other rights which vary from state to state. This warranty is void outside the United States of America.

PROCEDURE FOR OBTAINING PERFORMANCE OF WARRANTY: If, after following the instructions in this Operating Guide you are certain that the Product is defective, pack the Product carefully (preferably in its original packaging). Include evidence of original purchase and a note describing the defect that has caused you to return it. The Product should be shipped freight prepaid by traceable means, or delivered, to warrantor at:

Uniden America Corporation
Parts and Service
4700 Amon Carter Blvd.
Fort Worth, TX 76155

(800) 297-1023, 8:00 a.m. to 5:00 p.m. Central Time, Monday through Friday

Covered under one or more of the following U.S. patents:

4,622,553 4,698,632 4,709,407 4,791,420

4,831,498 5,315,302

uniden®

©1996 Uniden America Corporation. All rights reserved.
Printed in the Philippines

Free Manuals Download Website

<http://myh66.com>

<http://usermanuals.us>

<http://www.somanuals.com>

<http://www.4manuals.cc>

<http://www.manual-lib.com>

<http://www.404manual.com>

<http://www.luxmanual.com>

<http://aubethermostatmanual.com>

Golf course search by state

<http://golfingnear.com>

Email search by domain

<http://emailbydomain.com>

Auto manuals search

<http://auto.somanuals.com>

TV manuals search

<http://tv.somanuals.com>