

Uniden®

SSE17+1

OWNER'S MANUAL

Contents

Welcome	3	Setting Caller ID on Call Waiting (CIDCW) (Base only)	21
Terminology	4	Setting AutoTalk (Handset only)	21
Product Overview	5	Emergency Dialing From the Base & Cordless Handset	22
Main Phone Features	5	One-touch Speed Dialing from the Base	23
Answering Machine Features	5	Speed Dialing from the Memory	24
Parts of the Base and Corded Handset	6	Storing Names and Numbers for Speed Dialing	24
Parts of the Cordless Handset	8	Storing Caller ID Information to Speed Dial Locations	27
Parts of the Cordless Handset Charging Cradle	9	Using Your Phone	28
Using the Interface	10	During a Power Failure	28
Using the Base Menus	10	Making and Receiving Calls	29
Using the Handset Menus	10	Call Waiting	31
Installing the Phone	11	Redialing the Last Number Dialed	32
Choosing the Best Location	11	Adjusting the Ringer, Earpiece and Speaker Volume	33
Connecting the Base and Corded Handset	12	Audio Boost for the Cordless Handset	34
Testing the Connection	13	Selecting a Different Channel	35
Adjusting the Visual Ringer Brightness	14	Finding the Lost Handset	35
Wall Mounting the Base	15	Placing a Call on Hold from the Base	35
Connecting the Cordless Handset and Charger	17	Conferencing	36
Installing the Beltclip	18	Intercom	37
Installing the Optional Headset	18	Transferring a Call	38
Setup	19	Using Caller ID and Call Waiting	39
Setting the Day and Time (Base only)	19	Viewing Caller ID Information	40
Adjusting the Base Display (LCD Contrast)	19		
Name Tag	20		
Insert 0	20		

[1]

Deleting Information from the Caller ID List ..	41
Setting Up the Answering Machine	43
Features	43
Selecting a Language	43
Setting the Record Time (or Announce Only)	44
Activating Call Screening	44
Setting the Number of Rings	45
Activating the Message Alert	45
Setting Your Greeting	46
Selecting Your Greeting	47
Setting a Security Code or Personal Identification Number (PIN)	47
Using Your Answering Machine	48
Turning your Answering System On & Off	48
Reviewing Messages	49
Screening Calls	50
Remotely Operating Your Answering Machine	50
Maintenance	52
Specifications	52
Power Failure	52
Battery Life	53
Low battery alert	53
Battery Replacement and Handling	53
Installing the Rechargeable Battery for Cordless Handset	54
Cleaning the Battery Charging Contacts	55

Troubleshooting	56
Travelling Out of Range	56
Common Issues	56
Liquid Damage	59
Precautions	60
Important Safety Instructions	60
Index	61
Remote Operation Card.....	62
Warranty	66

Welcome

Congratulations on purchasing your new Uniden Corded/Cordless Telephone! Your new phone system comes with a corded base unit and a cordless handset. The corded base allows you the convenience, safety and security to make and receive calls during a power failure. In addition to the corded base, your new phone has a full featured cordless handset and charger that can be placed anywhere in your home where you have AC power and it does not require you to plug the handset in to a telephone line.

Note: Illustrations in this manual are used for explanation purposes.

Some illustrations in this manual may differ from the actual unit.

Terminology

Base	The main part of the phone that connects to your phone line and lets you make and receive calls.
Charger	A cradle that charges the handset battery. It connects to power but does not connect to a phone line.
CID	Caller ID is available from your telephone provider. With this service, you can see the name and number of incoming callers.
CIDCW	Caller ID on Call Waiting is available from your telephone provider. With this service, you can see incoming caller information while on another call.
Corded Handset on the Base	A handset connected to the Base. It can make and receive calls during a power failure.

Emergency Dial	One touch speed dial key for your most important or most frequently called number.
Handset	A cordless handset that can be placed anywhere in your home or office where AC power is available.
Standby	The handset is not in use. No line has been activated. The corded base handset is on the base and [■◀)] on the base has not been pressed. No dial tone is present.
Station	The Cordless handset or base phone.
Talk	When a dial tone has been enabled allowing the user to dial and carry on a conversation with an outside party.

Product Overview

Main Phone Features

- 2.4 GHz Extended Range Technology
- Corded/Cordless Telephone System
- Visual Ringer
- Large Backlit Keys
- Dual Keypad and Backlit Screens
- Make and Receive Calls During a Power Failure
- Integrated Answering Machine
- Base Speakerphone
- Caller ID and Caller ID on Call Waiting
- 50 Number Caller ID List
- One-Touch Emergency Dial in the Base and Cordless Handset
- 3 One-touch Speed Dial Numbers in the Base
- 10 Speed Dial Numbers in the Cordless Handset
- Ringer Volume Control
- Earpiece Volume Control
- Audio Boost for the Cordless Handset
- Hearing Aid Compatible
- Find Lost Handset
- Clock Display in the Base
- Intercom Between Cordless Handset and Base
- Hold Feature

Answering Machine Features

- Digital Tapeless Recording
- Up to 11 minutes of Recording Time
- Call Screening
- Personal or Pre-recorded Outgoing Messages
- Time and Day Announcement
- Remote Message Retrieval
- Toll Saver
- Message Alert

Parts of the Base and Corded Handset

Top view

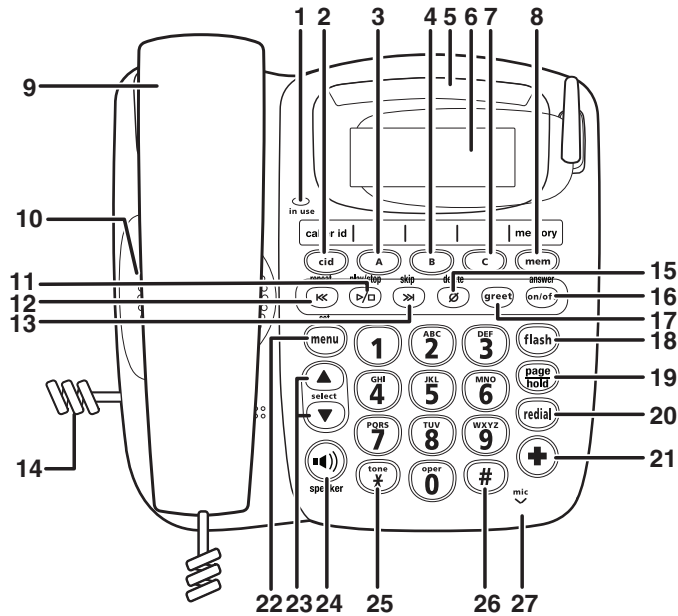

1. in use light
2. [cid] key
3. One-touch speed dial [A] key
4. One-touch speed dial [B] key
5. Base visual ringer

6. Base display
7. One-touch speed dial [C] key
8. [mem] (memory) key
9. Corded base handset
10. Base speaker
11. [▶|◻] (play/stop) key
12. [◀◀] (repeat/rewind) key
13. [▶▶] (skip/forward) key
14. Coiled cord
15. [∅] (delete) key
16. [on/off] key / answer on/off light
17. [greet] key
18. [flash] key
19. [page/hold] key
20. [redial/pause] key
21. Base Emergency [☒] key
22. [menu/set] key
23. [select/▲] key and [select/▼] key
24. [🔊] (speaker) key / speaker light
25. [*/tone] key
26. [#] key
27. Microphone

Side and Rear view

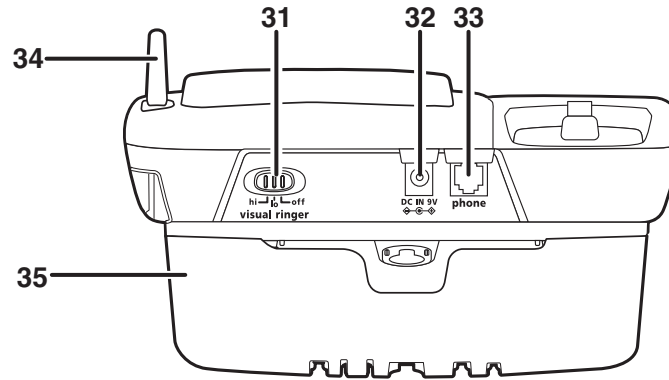
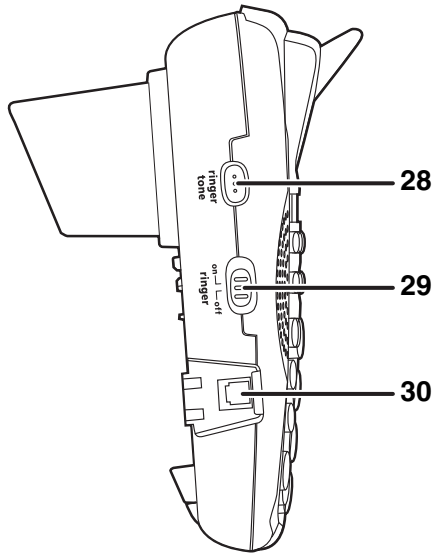

- | | |
|------------------------------------|------------------------|
| 28. ringer tone button | 32. DC IN 9V jack |
| 29. ringer on/off switch | 33. phone jack |
| 30. Coiled cord jack | 34. Base antenna |
| 31. visual ringer hi/lo/off switch | 35. Wall mount adapter |

Parts of the Cordless Handset

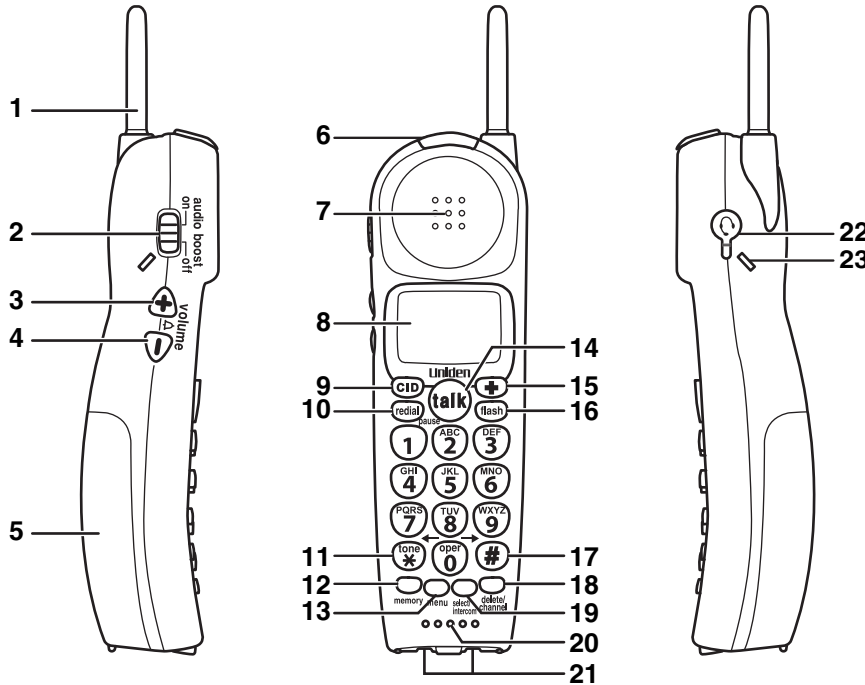

1. Handset antenna
2. **audio boost on/off** switch
3. Volume/ringer up [**volume/▲/+**] key
4. Volume/ringer down [**volume/△/-**] key
5. Handset battery compartment
6. Handset visual ringer
7. Handset earpiece
8. Handset display
9. **[CID]** key
10. **[redial/pause]** key
11. **[*/tone/ ←]** key
12. **[memory]** key
13. **[menu]** key
14. **[talk]** key
15. Handset Emergency [**☒**] key
16. **[flash]** key
17. **[#/→]** (pound) key
18. **[delete/channel]** key
19. **[select/intercom]** key
20. Handset microphone and ringer speaker
21. Handset charging contacts
22. Headset jack
23. Beltclip hole

Parts of the Cordless Handset Charging Cradle

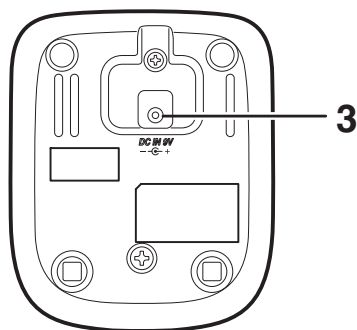
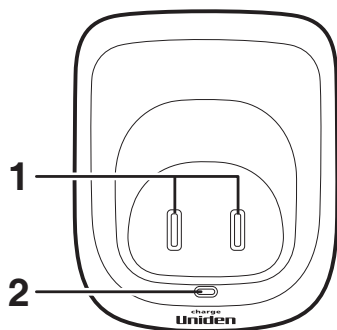

1. Charging contacts
2. Charge light
3. **DC IN 9V** jack

Using the Interface

Using the Base Menus

- Press [**menu/set**] on the base to access the base main menu.
- Use [**select/▲**] or [**select/▼**] to scroll through options.
- Press [**menu/set**] on the base to make a selection.
- For your convenience, voice prompts will guide you through the base main menu (except LCD Contrast settings).
- To cancel your selection and return to standby, press [**▶/□**] (play/stop) on the base.
- If you do not press a key within 30 seconds, the phone will time out and exit the menu. When setting Day and Time, the time-out period is extended to two minutes.

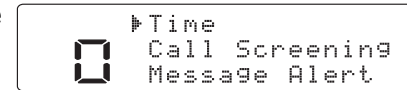
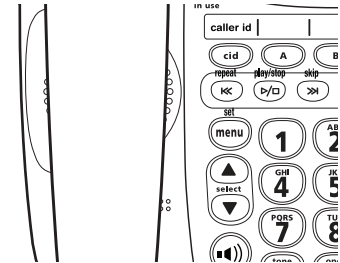

Using the Handset Menus

- Press [**menu**] on the cordless handset to access the main menu.
- Use [**volume/▲/+**] or [**volume/▲/-**] to scroll through the options.
- Press [**select/intercom**] on the cordless handset to make a selection.
- To return to standby, press [**menu**] on the cordless handset, or return the cordless handset to the cradle.

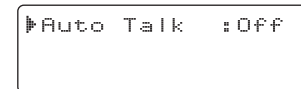
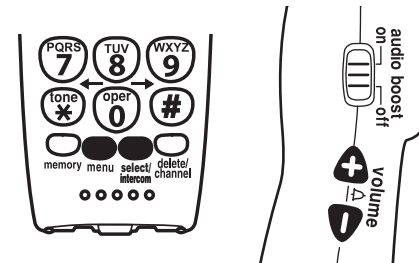

Installing the Phone

Choosing the Best Location

When choosing a location for your new phone, here are some important guidelines you should consider:

PLACE YOUR BASE

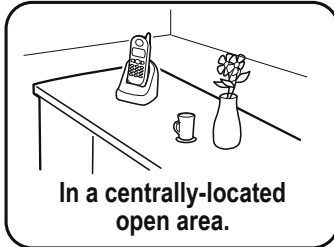
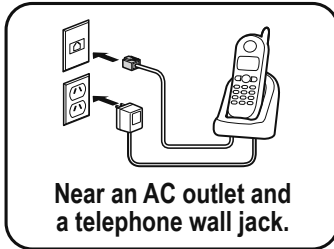

TRY TO AVOID

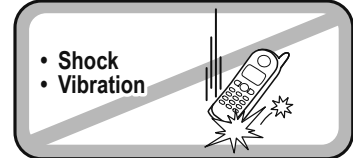
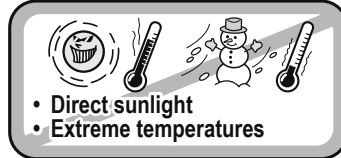
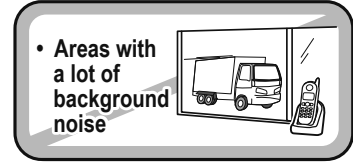
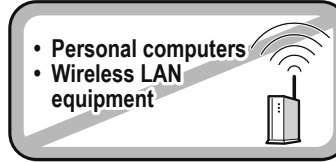
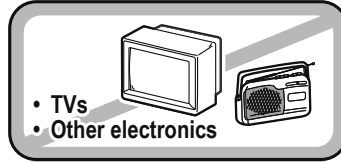
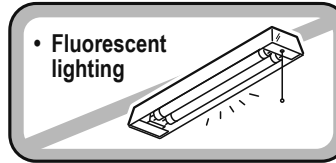
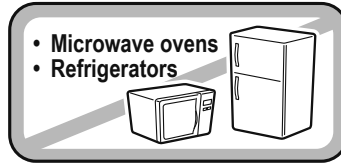

Notes: For maximum range:

Keep both the base and handset antennas free of obstruction.

When the handset is not in use, place the handset in an upright position.

Metal and reinforced concrete may affect cordless telephone performance.

Connecting the Base and Corded Handset

- 1) Connect the corded handset Coiled cord to the left side of the phone and to the corded handset.
- 2) Route the Coiled cord inside the molded wiring channel as shown.
- 3) Connect the AC adapter to the **DC IN 9V** jack and to a standard 240V AC wall outlet.

CAUTION: To avoid risk of fire and shock, only use the Uniden AAD-065S(M) AC adapter.

- 4) Route the AC adapter cord inside the molded wiring channel as shown.
- 5) Place the base unit close to the AC outlet to avoid long extension cords.
- 6) Connect the telephone cord to the **phone** jack and to a telephone outlet.
- 7) Set the base on a desk or tabletop. Place the corded base handset in the base cradle.

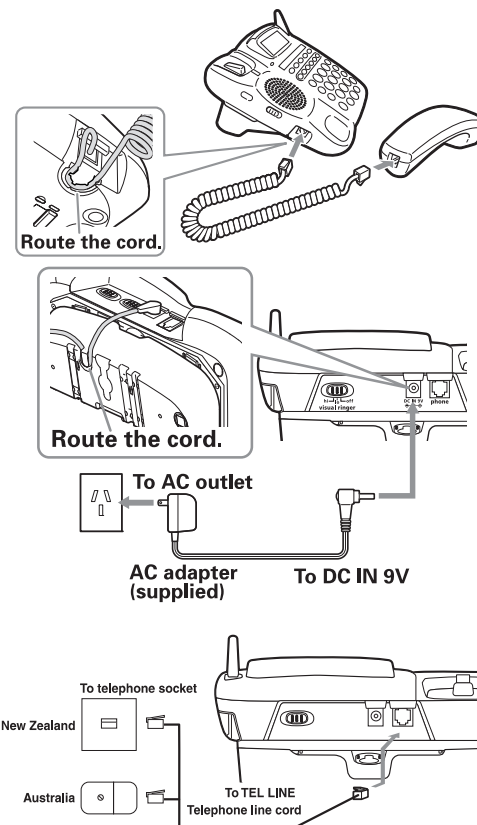

Testing the Connection

There's an easy way to test your connection: try making a call from your base. If your call connects, your phone's settings are fine. If your call does not connect:

Check the AC adapter cord. Make sure it is securely connected to the DC IN 9V connector and to a standard AC power outlet.

Adjusting the Visual Ringer Brightness

Your new phone has visual ringers located at the top of the base unit and at the top of the cordless handset. These visual ringers will flash during incoming calls, so if you are in a noisy work environment you will be able to see when the phone is ringing. The phone comes with a switch for base visual ringer control, so you can turn the visual ringers off when you do not want the base to flash brightly during incoming calls.

The **visual ringer hi/lo/off** switch allows you to set the brightness and turn off the visual ringer on the base. You can adjust the brightness by selecting one of three options: high, low and off. If you set the switch to off, the visual ringer on the base will not flash at all during incoming calls.

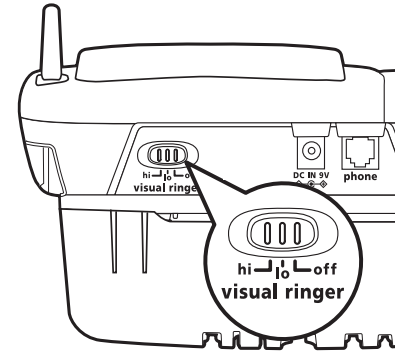

Wall Mounting the Base

This phone can be mounted on any standard wall plate.

- 1) Remove the wall mount adapter from the base and snap it into the notches on the bottom of the base.
- 2) Plug the AC adapter to the **DC IN 9V** jack.

CAUTION: To avoid risk of fire and shock, only use the Uniden AAD-065S(M) AC adapter.

- 3) Route the AC adapter cord inside the molded wiring channel as shown.
- 4) Plug the AC adapter into a standard 240V AC wall outlet.
- 5) Plug the telephone cord into the **phone** jack.
- 6) Route the telephone cord inside the molded wiring channel as shown.
- 7) Plug the telephone cord into the telephone outlet.
- 8) Align the mounting slots on the base with the mounting posts on the wall. Then push in and down until the phone is firmly seated.
- 9) On the base unit, pull the handset retainer out of the slot. Rotate it clockwise 180 degrees.

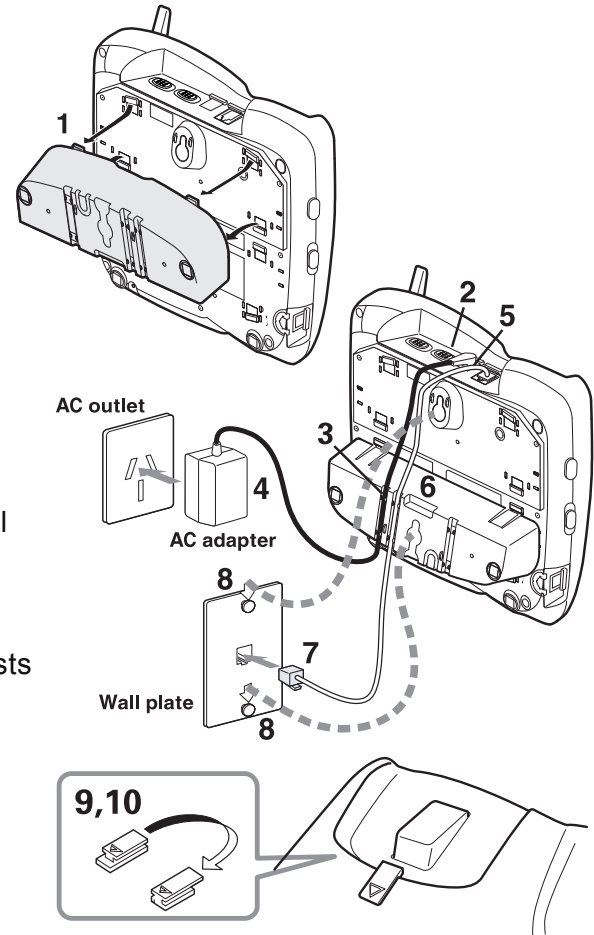

10) Flip the retainer from front to back. Slide it back into the slot so that the lip of the retainer is up and the oval is down. The retainer holds the handset in place.

Direct Wall Mounting

If you don't have a standard wall plate, you can mount your phone directly to the wall.

Before doing this, consider the following:

- Avoid electrical cables, pipes, or other items behind the mounting location that could cause a hazard when inserting screws into the wall.
- Try to mount your phone within 1.5m of a working phone jack to avoid excessive cord lengths.
- Make sure the wall material is capable of supporting the weight of the base and handset.
- Use #10 screws (minimum length of 35mm) with anchoring devices suitable for the wall material where the base unit will be placed.

1) Insert two mounting screws into the wall, (with their appropriate anchoring device), 100mm apart. Allow about 3mm between the wall and screw heads for mounting the phone.

2) Refer to steps 1 through 10 on page 15 to mount the telephone.

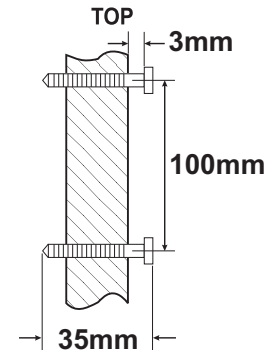

Connecting the Cordless Handset and Charger

The cordless handset is powered by a rechargeable battery pack. The battery recharges automatically when the handset is placed in the charger.

- 1) Connect the AC adapter to the **DC IN 9V** jack and to a standard 240V AC wall outlet.

CAUTION: Use only the Uniden AAD-600S(M) AC adapter.

- 2) Set the charger on a desk or tabletop, and place the handset in the charger with the keypad facing forward.
- 3) Make sure that the **charge** light illuminates. If the **charge** light does not illuminate, check to see that the AC adapter is plugged in and the handset makes good contact with the charging contacts.
- 4) Charge the handset battery pack for at least 15-20 hours before using your new cordless handset for the first time.
- 5) To test your connection, try making a call from the cordless handset. If your call does not connect, check to make sure the battery is fully charged. If you see **LOW BATTERY** on the cordless handset display, check to make sure the battery is properly connected. To check the battery, slide the battery compartment door open and check the battery cables to ensure a tight and proper connection. If your handset still does not work, please contact Uniden's Customer Service department. Please see inside the back cover for contact information.

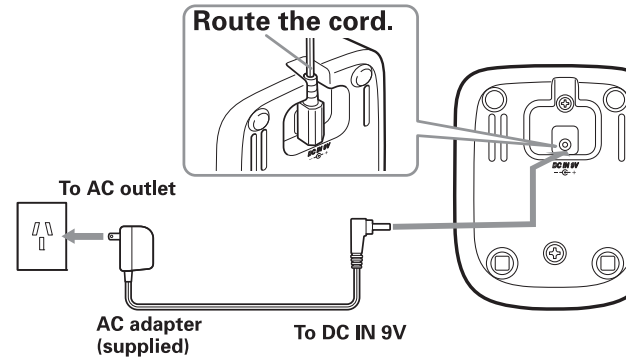

Installing the Beltclip

Line up the holes on each side of the cordless handset. To attach the beltclip, insert into the holes on each side of the handset. Press down until it clicks.

To remove the beltclip, pull either side of the beltclip to release the tabs from the holes.

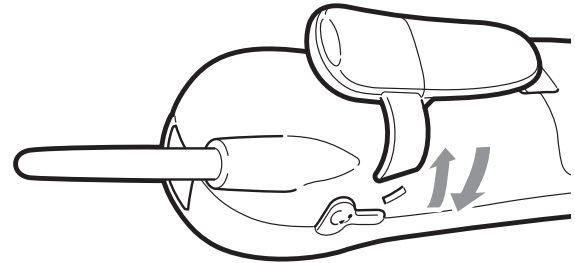

Installing the Optional Headset

Your cordless handset may be used with an optional headset. To use this feature, insert the headset plug into the headset jack. Your phone is ready for hands-free conversations. Headsets may be purchased by contacting Uniden. Please see inside back cover or visit www.uniden.com.au for Australian model or www.uniden.co.nz for New Zealand model for contact information.

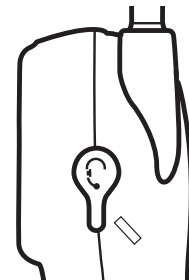

Setup

Setting the Day and Time (Base only)

To set the day and time on your phone, do the following:

- 1) Press **[menu/set]** on the base.
- 2) Press **[menu/set]** to select TIME. The system announces “Time”, the current time and the voice guidance for setting the time.
- 3) Press **[select/▲]** or **[select/▼]** to select the day of the week, and then press **[menu/set]**.
- 4) Enter a two-digit number (**01-12**) to set hour, and then press **[menu/set]**.
- 5) Enter a two-digit number (**00-59**) to set minute, and then press **[menu/set]**.
- 6) Press **[select/▲]** or **[select/▼]** to choose AM or PM, and then press **[menu/set]**. You will hear a confirmation tone.

Note: Use **[Ø]** (delete) to edit the hour and minute.



Adjusting the Base Display (LCD Contrast)

You can adjust the contrast or brightness of the text that appears on your base display. Choose one of ten levels for optimum viewing.

- 1) Press **[menu/set]** on the base.
- 2) Press **[select/▲]** to move the pointer to select LCD CONTRAST and then press **[menu/set]**.
- 3) Press **[select/▲]** or **[select/▼]** to adjust the contrast of the base display.
- 4) Press **[menu/set]**. You will hear a confirmation tone.



Name Tag

Name Tagging works with the Caller ID. You will need to subscribe to the Caller ID feature with your phone company for Name Tagging to work.

When the phone rings, the received caller display number is compared to numbers stored in the phonebook. If there is a match then any name stored with the phonebook number will be displayed. To change the Name Tagging setting, follow the steps listed below.

- 1) Press **[menu/set]** on the base or **[menu]** on the handset.
- 2) Press **[select/▼]** on the base or **[volume/▲/-]** on the handset to move the pointer to select NAME TAG. If you set from the base, press **[menu/set]** on the base.
- 3) Press **[select/▲]** or **[select/▼]** on the base or **[select/intercom]** on the handset to select ON or OFF.
- 4) Press **[menu/set]** on the base. You will hear a confirmation tone or press **[menu]** on the handset to complete the setting.

Insert 0

This feature adds “0” or “00” at the beginning of the number received from Caller ID. The default setting for New Zealand is ON. The default setting for Australia is OFF. To change the Insert 0 setting, follow the steps listed below.

- 1) Press **[menu/set]** on the base or **[menu]** on the handset.
- 2) Press **[select/▼]** on the base or **[volume/▲/-]** on the handset to move the pointer to select INSERT 0. If you set from the base, press **[menu/set]** on the base.
- 3) Press **[select/▲]** or **[select/▼]** on the base or **[select/intercom]** on the handset to select ON or OFF.
- 4) Press **[menu/set]** on the base. You will hear a confirmation tone or press **[menu]** on the handset to complete the setting.

[20]

Setting Caller ID on Call Waiting (CIDCW) (Base only)

Caller ID on Call Waiting (CIDCW) displays the name and number of an incoming call while you are on the line.

- 1) Press **[menu/set]** on the base.
- 2) Press **[select/▼]** to move the pointer to select CIDCW, and then press **[menu/set]**.
- 3) Press **[select/▲]** or **[select/▼]** to select ON or OFF, and then press **[menu/set]**. You will hear a confirmation tone.



Setting AutoTalk (Handset only)

AutoTalk allows you to answer the phone simply by removing the cordless handset from the cradle. You do not have to press any keys to answer the call.

- 1) Press **[menu]** on the cordless handset.
- 2) Press **[select/intercom]** to select Auto Talk ON or OFF.
- 3) Press **[menu]** to complete the setting. The handset returns to standby.

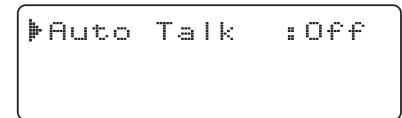

Emergency Dialing From the Base & Cordless Handset

Your corded base phone and cordless handset comes with a special Emergency Speed Dial [☒] key that is already pre-programmed to dial 000 for Australian model, 111 for New Zealand model when pressed. This key can be re-programmed with another special emergency dial number of your choice by following these steps:

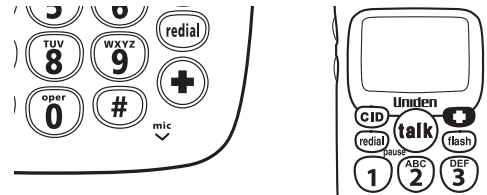

- 1) With the phone in standby, press and hold the Emergency Dial [☒] key on the base or the cordless handset. If the Emergency Dial number is already programmed, the Edit screen appears. You can select EDIT NUMBER to edit this entry, select DELETE NUMBER to erase this entry or select GO BACK to return to the previous screen.
- 2) Store the number by following step 6 under *Storing Names and Numbers for Speed Dialing* on page 26.
- 3) Press [menu/set] on the base or [select/intercom] on the handset. You will hear a confirmation tone, and NUMBER STORED appears. Memory storage is complete.

Note:

- When editing the Emergency Dial number, you must press a key within 30 seconds or the phone will return to standby.
- The Emergency Dial number can be up to 48 digits on the base and up to 20 digits on the handset.
- When [☒] on the base is pressed, base visual ringer tells you by flashing.

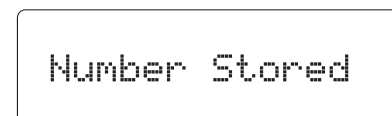
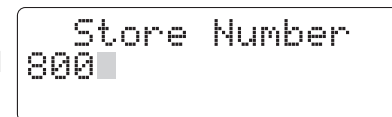
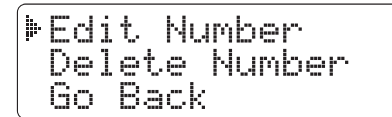
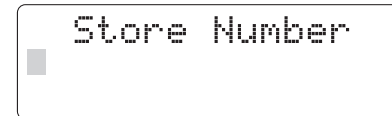

- If you press [M] accidentally, press [M]) on the base or [talk] on the handset to cancel the dialing.

One-touch Speed Dialing from the Base

The base has 3 one-touch speed dial locations ([A], [B] and [C]) that can be programmed for special or frequently dialed numbers. Use the following steps to set up these speed dial numbers:

- 1) With the base in standby, press and hold [A], [B], or [C].

If the key already has a number programmed, the Edit screen appears. You can select EDIT NUMBER to edit this entry, select DELETE NUMBER to erase this entry or select GO BACK to return to the previous screen.

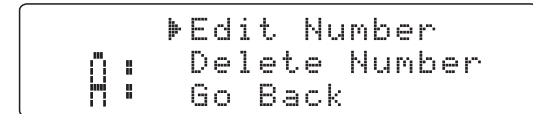
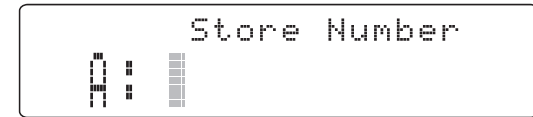

- 2) Store the number by following step 6 under *Storing Names and Numbers for Speed Dialing* on page 26.



- 3) Press [menu/set] on the base. You will hear a confirmation tone, and NUMBER STORED appears. Memory storage is complete.

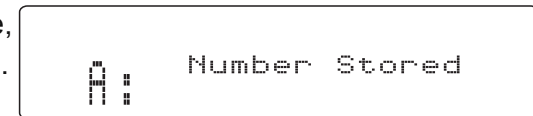

Note:

- When editing these Speed Dial numbers, you must press a key within 30 seconds or the phone will return to standby.
- The One-touch Speed Dial number can be up to 48 digits.

To make a call from a one-touch speed dial, simply press one of the one-touch speed dial keys [A-C], and your phone will automatically dial the number.

[23]

Speed Dialing from the Memory

Your corded base and cordless handset allows you to store up to 10 names and numbers each for quick and easy dialing of frequently called numbers. The numbers stored on the base and handset are independent of each other.

These 10 speed dials are not limited to just phone numbers. You can store any number (up to 20 digits) that you need to enter once your call connects. This is referred to as **Chain Dialing**. For example, you can save your bank account number to a speed dial. When you call your bank's telephone teller service and are prompted to enter your account number, simply press **[mem]** on the base or **[memory]** on the handset and the speed dial number where you stored your account number. Then press **[menu/set]** on the base or **[select/intercom]** on the handset. Or you can save and store prescription drug information for fast and easy reordering with your pharmacy.

Note: When editing a Speed Dial, you must press a key within 30 seconds or the phone will return to standby.

Storing Names and Numbers for Speed Dialing

- 1) With the phone in standby, press **[memory]** on the handset or **[mem]** on the base.
- 2) Enter **[0-9]** to select the speed dial number where you would like to store this entry. You can also scroll through the list with **[volume/▲/+]** or **[volume/▲/-]** on the handset (**[select/▲]** or **[select/▼]** on the base). Press **[select/intercom]** on the handset or **[mem]** on the base.



```
Select Memory
1 [Empty]
2 JOHN DOE
```

- 3) STORE NAME appears and a cursor flashes indicating that the display is ready for the name to be entered.

If the selected speed dial number is already assigned, the Edit screen appears. You can select MAKE A CALL to dial the number, select EDIT MEMORY to edit this entry, select DELETE MEMORY to erase this entry, or select GO BACK to choose another speed dial number.

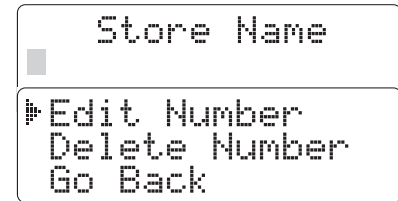

- 4) Enter a name according to the instructions below.

- The name can be up to 14 characters.
- Use [***/tone/←**] and [**#/→**] to move the cursor to the desired location.
- Use [**delete/channel**] on the cordless handset ([**∅**] (delete) on the base) to delete characters as needed.
- Press and hold [**delete/channel**] on the cordless handset ([**∅**] (delete) on the base) to delete all the characters.
- If no name is required, go to step 5.

Refer to the letters on the number keys to select the desired characters.

Each time you press a numeric key, the displayed character appears in the following order: Upper case letters first, lower case letters next and finally the number corresponding to the key.

If you make a mistake while entering a name

Use [***/tone/←**] and [**#/→**] to move the cursor to the incorrect character.

Press [**delete/channel**] on the cordless handset ([**∅**] (delete) on the base) to erase the wrong character. Then enter the correct character. To delete all characters, press and hold [**delete/channel**] on the cordless handset ([**∅**] (delete) on the base).

For example, to enter **Movies**:

- 1) Press **[6]** once to enter **M**.
Then press **#[/→]** to move the cursor to the right.
- 2) Press **[6]** six times to enter **o**.
- 3) Press **[8]** six times to enter **v**.
- 4) Press **[4]** six times to enter **i**.
- 5) Press **[3]** five times to enter **e**.
- 6) Press **[7]** eight times to enter **s**.

	Number of times key is pressed								
keys	1	2	3	4	5	6	7	8	9
1	1								
2 ABC	A	B	C	a	b	c	2		
3 DEF	D	E	F	d	e	f	3		
4 GHI	G	H	I	g	h	i	4		
5 JKL	J	K	L	j	k	l	5		
6 MNO	M	N	O	m	n	o	6		
7 PQRS	P	Q	R	S	P	q	r	s	7
8 TUV	T	U	V	t	u	v	8		
9 WXYZ	W	X	Y	Z	w	x	y	z	9
0 oper	*	#	-	&	()	(blank)	0	

- 5) Press **[select/intercom]** on the handset (**[menu/set]** on the base). STORE NUMBER is displayed. The cursor flashes indicating that the display is ready for the number to be entered

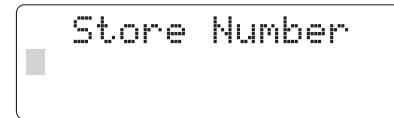

- 6) Use the keypad to enter the phone number; each number can be up to 20 digits. If you need the phone to pause during the dialing sequence, press **[redial/pause]** on the handset (**[redial/pause]** on the base). to insert a two-second pause between the numbers. You can enter multiple pauses to increase the delay. Each pause counts as a digit. The display shows a P for every pause.

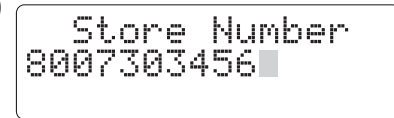

Note: If the next character uses the same number key, you must press **#[/→]** to move the cursor over. Otherwise the next time you press the number key, it changes the character that was previously set.

7) Press **[select/intercom]** on the handset (**[menu/set]** on the base). You will hear a confirmation tone.

```
Memory 1 Stored
```

8) After about 2 seconds, the speed dial entries will appear.

```
1▶ Movies  
2 JOHN DOE  
3 MOM AND DAD
```

9) Press **[memory]** on the handset (**[mem]** on the base) to exit memory setup mode. The phone returns to standby.

Storing Caller ID Information to Speed Dial Locations

Caller ID names & numbers shown in the Caller ID list can be stored to a speed dial location.

For instructions on viewing the Caller ID information, see page 40. If the Caller ID information did not include the phone number, then you will not be able to store it.

Follow these steps to store a Caller ID name and number to a speed dial location:

1) Press **[CID]** on the handset (**[cid]** on the base). Select the phone number to be stored from the Caller ID list by pressing **[volume/▲/+]** or **[volume/▲/-]** on the handset (**[select/▲]** or **[select/▼]** on the base).

```
17/5 12:30PM 03  
Jane Smith  
2145551234
```

2) Press **[memory]** on the handset (**[mem]** on the base).

```
Select Memory  
1▶ <Empty>  
2 JOHN DOE
```

3) Enter a number [0-9] or press [volume/▲/+] or [volume/▲/-] on the handset ([select/▲] or [select/▼] on the base) to select the memory location to be stored.

```
17/ 5 12:30PM
Jane Smith
2145551234
```

4) Press [select/intercom] on handset ([menu/set] on base). You will hear a confirmation tone, and the number is stored in memory. The display returns to the Caller ID data.

Note: If a message has already been stored in the selected memory number location, a confirmation screen is displayed. Press [volume/▲/+] on the handset ([select/▲] on the base) to select YES. Press [select/intercom] on the handset ([menu/set] on the base) to overwrite. The display returns to the Caller ID data.

```
Replace Memory?
Yes
▶ No
```

Using Your Phone

During a Power Failure

Because the phone is a corded/cordless combination phone, it can still perform several of its functions during a power failure. The following features will function with base corded handset even during a power failure:

- Making and receiving calls with the base corded handset
- Using your Emergency Dial [☒] key after picking up the base corded handset
- Using your one-touch speed dial [A-C] keys after picking up the base corded handset
- Adjusting the volume (Base corded handset only)
- Call Waiting (Base corded handset only)
- Redialing the last number dialed (Base corded handset only)

All other features are disabled during a power failure.

Making and Receiving Calls

	From the cordless handset	From the base speakerphone	From the base corded handset
Making a call	1) Pick up the handset from the cradle. 2) Press [talk] . 3) Listen for the dial tone. 4) Dial the number. OR 1) Remove the handset from the cradle. 2) Dial the number. 3) Press [talk] .	1) Press [Mute] . 2) Listen for the dial tone. 3) Dial the number. OR 1) Dial the number. 2) Press [Mute] .	1) Pick up the corded handset. 2) Listen for the dial tone. 3) Dial the number. OR 1) Dial the number. 2) Pick up the corded handset.
	Note: To insert a two-second pause in the dialing sequence in standby, press [redial/pause] . A P appears in the display.		
Receiving a call	1) Pick up the handset from the cradle. (If AutoTalk is on, the phone answers automatically when you pick up the handset from the charging cradle.) 2) Press [talk] . OR If the handset is off the cradle, press [talk] . (If AutoTalk is on, you can press any key in the twelve number keypad.)	Press [Mute] .	Pick up the corded handset.
Hanging Up	Press [talk] or return the handset to the cradle.	Press [Mute] .	Return the corded handset to the base.

[29]

Switching between the Base Speakerphone and Corded Handset During a Call

To switch a call from the corded handset on the base to the base speakerphone, press **[Mute]** on the base.

To switch from a base speakerphone call to the base corded handset, pick up the corded handset.

Making a Call from the Base One-Touch Speed Dial Locations

Simply press one of the three (3) One-touch Speed Dial **[A-C]** keys on the base, and your phone will automatically dial the number. To cancel, press **[Mute]** on the base.

Making a Call from the Emergency Dial or Speed Dial Locations

Simply press the Emergency Dial **[+]** key on the base or cordless handset and your phone will automatically dial the number. To cancel, press **[Mute]** on the base or **[talk]** on the cordless handset.

To dial one of the speed dial numbers, simply follow these steps:

- 1) Press **[memory]** on the handset (**[mem]** on the base). The handset (or base if base key is pressed) displays your programmed speed dial numbers.
- 2) Enter the number **[0-9]**, or press **[volume/Δ/+]** or **[volume/Δ/-]** on the handset (**[select/▲]** or **[select/▼]** on the base) to select the speed dial number you would like to dial.
- 3) Press **[talk]** on the handset (**[Mute]**) on the base) and the displayed number is dialed.



```
Select Memory
1 Movies
2 JOHN DOE
```

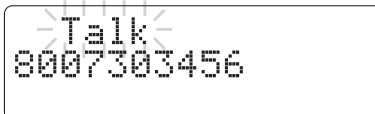

```
Talk
8007303456
```

To cancel speed dialing

Press **[Mute]** on the base or **[talk]** on the handset again to cancel speed dialing. The phone returns to standby. Also, if the phone is idle (e.g., no key is pressed) for 30 seconds, the phone returns to standby.

Easy dialing

If you want to directly access the speed dial location, press and hold **[0-9]** when the handset or base is in standby, and when the stored number appears, press **[*]]]** on the base or **[talk]** on the handset.

Making a Call from a Caller ID Listing

You can place a call from the Caller ID list.

- 1) Press **[cid]** on the base or **[CID]** on the cordless handset.
- 2) Select the phone number that you want to dial by pressing **[select/▲]** or **[select/▼]** on the base, or **[volume/▲/+]** or **[volume/▲/-]** on the handset.
- 3) Press **[*]]]** on the base or **[talk]** on the handset or remove the corded handset from the base. The displayed phone number dials automatically.



```
17/5 12:30PM 03
Jane Smith
2145551234
```

Note:

- You can also press **[*]]]** on the base or **[talk]** on the handset.
or remove the corded handset from the base before finding the phone number you want to dial. When you come to the phone number you want to dial, press **[menu/set]** on the base or **[select/intercom]** on the handset.
- You cannot make a call from the Caller ID list if your cordless phone is connected to a private branch exchange (PBX).

Call Waiting

If you subscribe to Call Waiting service, you can receive calls while on the line.

- 1) If a call comes in while you are on the phone, you will hear a call waiting tone. If you have CIDCW activated, you will see the name and number of the incoming caller.

For Australian model: Press **[flash]** and then **[2]** on the base or cordless handset to switch between callers.

For New Zealand model: Press **[flash]** on the base or cordless handset to switch between callers.

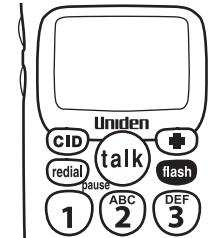

Tip: You must subscribe through your local telephone company to receive Call Waiting service.

Redialing the Last Number Dialed

From the cordless handset	From the base speakerphone	From the base corded handset
<ol style="list-style-type: none"> 1) Pick up the handset from the cradle. 2) Press [talk]. 3) Listen for the dial tone. 4) Press [redial/pause]. <p>OR</p> <ol style="list-style-type: none"> 1) Pick up the handset from the cradle. 2) Press [redial/pause]. 3) Press [talk]. 	<ol style="list-style-type: none"> 1) Press [redial/pause]. 2) Listen for the dial tone. 3) Press [redial/pause]. <p>OR</p> <ol style="list-style-type: none"> 1) Press [redial/pause]. 2) Press [redial/pause]. 	<ol style="list-style-type: none"> 1) Pick up the corded handset. 2) Listen for the dial tone. 3) Press [redial/pause]. <p>OR</p> <ol style="list-style-type: none"> 1) Press [redial/pause]. 2) Pick up the corded handset.

Adjusting the Ringer, Earpiece and Speaker Volume

Adjusting the Base Ringer

Ringer on/off: The **ringer on/off** switch allows you to set the base ringer on or off. If you set the switch to off, the base ringer will be silent.

Ringer tone: Press the **ringer tone** button in standby to select one of 7 ring tones.

Ringer volume: The base has ten settings for ringer volume.

- 1) With the phone in standby, press **[select/▲]** or **[select/▼]**.
- 2) The base will sound the ringer volume at the selected setting and display the new ringer volume.

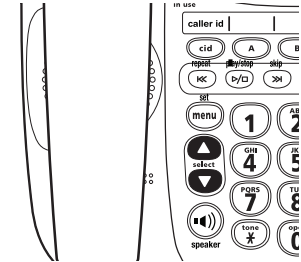
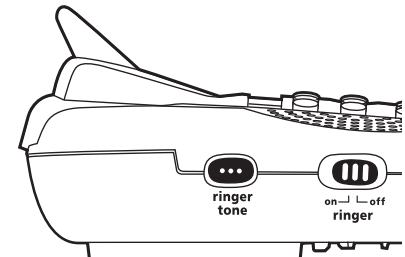

Adjusting the Handset Ring Tone and Volume

Your cordless handset has two different ring tones (A and B) and two different volumes for each (low and high).

- 1) With the phone in standby, press **[volume/▲/+]** or **[volume/▲/-]** to cycle through Ringer A High, Ringer A Low, Ringer B High, Ringer B Low, and Ringer off.
- 2) The phone will sound the different ring tones at different volumes. To turn the ringer off, select Ringer Off.

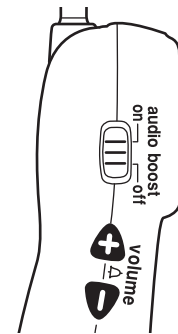

Adjusting the Earpiece and Speaker Volume

Base Speakerphone: You can select eight different volume levels for the base speaker. To adjust the base speaker volume while on a call, press **[select/▲]** (to make it louder) or **[select/▼]** (to make it softer). This setting will remain in effect after the telephone call has ended.

Base Corded Handset: You can select the earpiece volume from among four volume levels. To adjust the earpiece volume of corded handset while on a call, press **[select/▲]** (to make it louder) or **[select/▼]** (to make it softer). This setting will remain in effect after the telephone call has ended.

Cordless Handset: You can select the earpiece volume from among four volume levels. To adjust the earpiece volume of cordless handset while on a call, press **[volume/▲/+]** (to make it louder) or **[volume/▲/-]** (to make it softer). This setting will remain in effect after the telephone call has ended.

Temporarily Muting the Base Ringer

To mute the ring tone temporarily for the base, when the phone is ringing, press **[▶/□]** (play/stop) on the base. The mute will last for the current incoming call only. The ring tone will return to the previous setting starting with the next incoming call.

Audio Boost for the Cordless Handset

This feature allows you to hear phone conversations more clearly by boosting the high audio frequency tones.

To set audio boost on, slide the **audio boost on/off** switch upward. BOOST ON appears on the handset display under the volume setting when you start a call. To set audio boost off, slide the **audio boost on/off** switch downward.

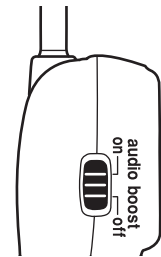

Selecting a Different Channel

If you encounter interference while using your cordless handset, you can manually change the handset's channel for clear operation. While using your handset, press **[delete/channel]**. SCANNING appears on the display, indicating the handset is changing to another channel.

Finding the Lost Handset

If you misplace the cordless handset, press **[page/hold]** on the base. The visual ringer on the cordless handset flashes, and the cordless handset will beep for 60 seconds.

To cancel a find handset page, press **[page/hold]** on the base. Paging is also canceled when the phone receives an incoming call.

Placing a Call on Hold from the Base

- 1) During a call from the base, press **[page/hold]**. The call will be put on hold.
- 2) To return to the call, press **[page/hold]** again, pick up the corded handset or press **[talk]** on the base. To talk to the caller from the cordless handset, press **[talk]** on the cordless handset.

Note:

- You can place a call on hold for ten minutes. When ten minutes has passed, the call is disconnected, and the phone automatically returns to standby.
- You can return the corded handset to the base while a call is on hold, and the call will remain on hold.

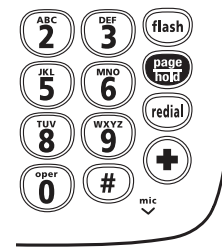

Conferencing

With this phone system, up to three people can participate in a conference call while using an outside line, the cordless handset, and the base.

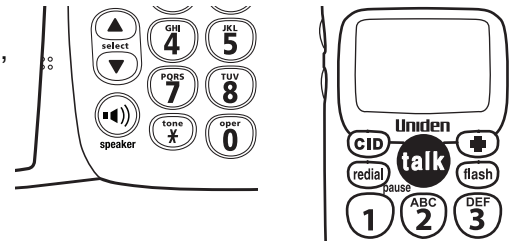

Joining a Conference Call

You can easily join a call already in progress.

	From the cordless handset	From the base speakerphone	From the base corded handset
Joining the conference call	During a call from the base, press [talk] on the handset.	During a call from the cordless handset, press [speaker] on the base.	During a call from the cordless handset, pick up the corded base handset.
Exiting the conference call	Press [talk] on the handset or return the handset to the cradle. The base will still be connected to the call.	Press [speaker] on the base. The cordless handset will still be connected to the call.	Return the corded handset to the base cradle. The cordless handset will still be connected to the call.

Intercom

The intercom feature lets you communicate between the cordless handset and base without using the phone line. You can make an intercom call while an outside caller is on hold; making an intercom call will not terminate the call on hold. If the party does not answer within one minute, the operation is canceled.

Making an Intercom Page

	From the cordless handset	From the base speakerphone	From the base corded handset
Making an Intercom Page (in standby)	1) Press [select/intercom] . 2) The base will be paged. An intercom tone sounds. To cancel the Page: Press [select/intercom] or return the handset to the cradle.	1) Press [page/hold] . 2) The handset will be paged. An intercom tone sounds. To cancel the Page: Press [page/hold] or [MUTE] .	1) Press [page/hold] . 2) The handset will be paged. An intercom tone sounds. 3) Pick up the corded handset. To cancel the Page: Press [page/hold] or return the corded handset to the base.
Making an Intercom Page (During a call)	1) Press [select/intercom] . 2) The call will automatically be placed on hold, and the paging tone sounds. To cancel the Page: Press [select/intercom] or [talk] .	1) Press and hold [page/hold] . 2) The call will automatically be placed on hold, and the paging tone sounds. To cancel the Page: Press [page/hold] or [MUTE] .	1) Press and hold [page/hold] . 2) The call will automatically be placed on hold, and the paging tone sounds. To cancel the Page: Press [page/hold] .

Answering and Hanging up an Intercom Page

	On the cordless handset	With the base speakerphone	With the base corded handset
Answering an Intercom Page	<p>1) Pick up the handset from the cradle. (If AutoTalk is on, the phone answers automatically when you pick up the handset from the charging cradle.)</p> <p>2) Press [select/intercom] or [talk]. OR If the handset is off the cradle, press [select/intercom] or [talk]. (If AutoTalk is on, you can press any key in the twelve number keypad.)</p>	Press [page/hold] or [MUTE] .	Pick up the corded handset.
Hanging up an Intercom Page	Press [select/intercom] or [talk] .	Press [MUTE] .	Return the corded handset to the base.

Transferring a Call

You can transfer a call from one station to another. You may also place a call on hold, intercom page the other station and then transfer the call to that station.

During a call, press and hold **[page/hold]** on the base or press **[select/intercom]** on the cordless handset. To transfer the call, the other station must answer. The station transferring the call may now hang up.

Using Caller ID and Call Waiting

You must subscribe to Caller ID service through your local telephone provider to use this feature.

When the telephone rings, the Caller ID feature allows you to view the caller's phone number, date and time of call, and Name Tag (POP ID) feature allows you to view the caller's name (see page 20). The incoming call information is stored in the Caller ID record.

If you subscribe to Caller ID on Call Waiting (CIDCW) you can view a second caller's information first (see Using Call Waiting on page 31 to answer call). The CIDCW service is currently unavailable in New Zealand.

Base

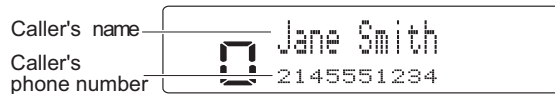

Cordless Handset

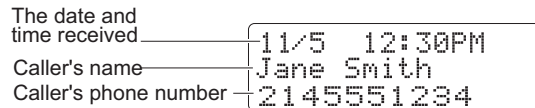

You may receive any one of the following messages:

When invalid data is received;	INCOMPLETE DATA
When a private name is received;	PRIVATE NAME
When a private number is received;	PRIVATE NUMBER
When an unknown name is received;	UNKNOWN NAME
When an unknown number is received;	UNKNOWN NUMBER
When an overseas call(0000) is received (New Zealand only):	OVERSEAS CALL
When a call is coming from a payphone (Australia only):	PAYPHONE

Note: Data errors will appear on the display as “■.”

Viewing Caller ID Information

With a Caller ID subscription from your local telephone company, you have two different ways to view Caller ID information. The first way is to look at your cordless handset or base unit when you receive an incoming call. The second is to view your Caller ID history list. To view your CID list, follow these steps:

- 1) With the phone in standby, press **[CID]** on the cordless handset (**[cid]** on the base). The summary screen appears. The screen shows the number of new messages and total messages.
- 2) To view the Caller ID information in historical order (from new to old or from old to new), use **[volume/▲/-]** on the cordless handset (**[select/▼]** on the base) to scroll through the data from the latest to the earliest, or **[volume/▲/+]** on the cordless handset (**[select/▲]** or on the base) to scroll back through the messages.
- 3) To finish viewing the CID information, press **[CID]** on the cordless handset (**[cid]** on the base).

```
Caller ID
New   :01
Total:02
```

```
17/5  12:30PM 03
Jane Smith
2145551234
```

While viewing Caller ID information from your CID list, you may notice that a number will appear next to the received time of some Caller ID information. This indicates the number of times that you have received a call from that number. Once you view the information, the number will be cleared.

While viewing or deleting Caller ID information, if you do not press a key within 30 seconds, an error tone will sound and your phone will return to standby. Also, if you receive an incoming call or intercom page while viewing Caller ID information, your operation will be canceled allowing you to answer the call or intercom page.

Deleting Information from the Caller ID List

The cordless phone stores up to 50 Caller ID names and numbers. If the phone receives the 51st Caller ID, the oldest one in the list is automatically deleted. Individual Caller ID data can also be deleted manually by following these steps:

- 1) Press **[CID]** on the cordless handset (**[cid]** on the base) while in standby.
- 2) Find the message to be deleted from the Caller ID list by pressing **[volume/▲/+]** or **[volume/▲/-]** on the cordless handset (**[select/▲]** or **[select/▼]** on the base).
- 3) Press **[delete/channel]** on the cordless handset (**[∅]** (delete) on the base).
- 4) Press **[volume/▲/+]** on the cordless handset (**[select/▲]** on the base) to select YES, and then press **[select/intercom]** on the cordless handset (**[menu/set]** on the base).

You will hear a confirmation tone.

```
Caller ID
New :01
Total:02
```

```
17/5 12:30PM 03
Jane Smith
2145551234
```

```
Delete Message?
▶ Yes
No
```

To Delete the entire Caller ID List:

- 1) Press **[CID]** on the cordless handset (**[cid]** on the base) while in standby.
- 2) Press **[delete/channel]** on the cordless handset (**[Ø]** (delete) on the base).
- 3) Press **[volume/Δ/+]** on the cordless handset (**[select/▲]** on the base) to select YES, and then press **[select/intercom]** on the cordless handset (**[menu/set]** on the base).

You will hear a confirmation tone and all Caller ID information is deleted.



```
Caller ID  
New :01  
Total:02
```

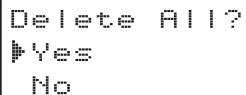

```
Delete All?  
▶ Yes  
No
```



```
Caller ID  
Total:00
```

Setting Up the Answering Machine

The phone has a built-in answering machine that answers and records incoming calls.

You can also use your system to announce a special outgoing message to callers when you are away from your phone.

Features

- Digital Tapeless Recording
- Up to 11 minutes of Recording Time
- Call Screening
- Personal or Pre-recorded Outgoing Messages
- Time and Day Announcement
- Remote Message Retrieval
- Toll Saver
- Message Alert

Setting the Record Time (or Announce Only)

You can select how long a caller has to record a message. You have three record time options. The options 1 MINUTE or 4 MINUTES set the duration for recording the incoming messages. ANNOUNCE ONLY answers the call and plays either your personal greeting or the pre-recorded system greeting, but prevents the caller from leaving a message.

- 1) Press **[menu/set]** on the base.
- 2) Press **[select/▼]** to move the pointer to select RECORD TIME, and then press **[menu/set]**.
- 3) Press **[select/▲]** or **[select/▼]** to select Record Time 1 MINUTE, 4 MINUTES, or ANNOUNCE ONLY.
- 4) Press **[menu/set]**. You will hear a confirmation tone.

Note:

- For your convenience, voice prompts will guide you through the menus.
- Press **[▶/□]** (play/stop) on the base to return to standby.
- If you do not press a key within 30 seconds, the phone will time out and exit the menu.



Activating Call Screening

Your phone allows you to listen to callers leaving you a message. This feature can be turned on or off with the following steps:

- 1) Press **[menu/set]** on the base.
- 2) Press **[select/▼]** to move the pointer to select CALL SCREENING, and then press **[menu/set]**.

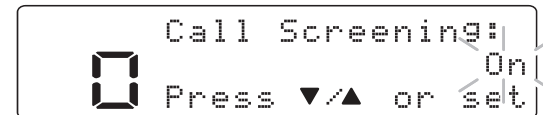

- 3) Press **[select/▲]** or **[select/▼]** to select ON or OFF.
- 4) Press **[menu/set]**. You will hear a confirmation tone.

Setting the Number of Rings

The ring time setting allows you to set the number of rings the caller hears before your answering machine plays the outgoing message. You can set the ring time to answer after six, nine or twelve rings. If you enable the Toll Saver, the answering machine picks up after six rings if you have new messages and after nine rings if there are none.

- 1) Press **[menu/set]** on the base.
- 2) Press **[select/▼]** to move the pointer to select RING TIME, and then press **[menu/set]**.
- 3) Press **[select/▲]** or **[select/▼]** to select a Ring Time (TOLL SAVER, 6 TIMES, 9 TIMES or 12 TIMES).
- 4) Press **[menu/set]**. You will hear a confirmation tone.



Activating the Message Alert

The Message Alert feature sounds a short alert tone every 15 seconds whenever you have a new message. Once all new messages have been played, the alert tone automatically stops beeping until you receive another new unplayed message.

- 1) Press **[menu/set]** on the base.
- 2) Press **[select/▼]** to move the pointer to select MESSAGE ALERT, and then press **[menu/set]**.

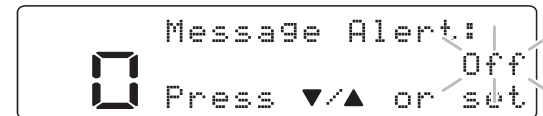

- 3) Press [**select/▲**] or [**select/▼**] to select ON or OFF.
- 4) Press [**menu/set**]. You will hear a confirmation tone.

To quickly turn off the Message Alert tone, press any key on the base unit; the tone will automatically quiet until you receive another new message.

Setting Your Greeting

When you receive a call, the answering machine automatically plays either the pre-recorded message or your own greeting. Your answering machine comes with the following pre-recorded message:

“Hello, no one is available to take your call. Please leave a message after the tone.”

Or you can record your own personal outgoing greeting. Your recorded greeting must be between 2 seconds and 30 seconds long. Once you have recorded a personal greeting, you can switch back and forth between the pre-recorded greeting and your own personal greeting.

To Record a Personal Greeting:

- 1) Press [**greet**]. While the pre-recorded message is playing, press and hold [**greet**] again. You will hear the announcement “Record greeting” and a confirmation tone.

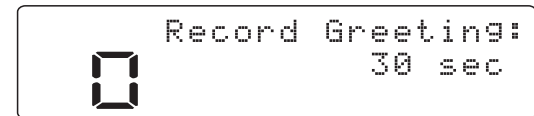

If you already have a greeting recorded, you can delete the current one and then record a new greeting. While the current greeting is playing, press [**Ø**] (delete). And then start over with the first.

- 2) Start recording your message. You will have 30 seconds, and the message counter will count down. When you are finished recording your greeting, press **[greet]**, **[▶/□]** (play/stop) or **[menu/set]**. You will hear a confirmation tone, and then your greeting plays back for you.

Note:

- **Position yourself as close to the base as possible and speak clearly when recording your greeting.**
- **If you make an outside call or a call is received during the new greeting recording, the operation is canceled.**
- **The greeting must be more than two seconds long, or it will not be recorded.**
- **To delete the personal greeting, press [Ø] (delete) while the message is playing. The system announces “Greeting has been deleted.”**

Selecting Your Greeting

You can switch back and forth between your personal greeting and the pre-recorded system greeting. With the phone in standby, press **[greet]**. Then press **[greet]** again while the outgoing greeting is played. This switches between the prerecorded greeting and the personal greeting. After your greeting selection plays back, a confirmation tone is heard.

Setting a Security Code or Personal Identification Number (PIN)

To play your messages from a remote location outside of your home, you will need to enter a two-digit Security code or Personal Identification Number (PIN).

- 1) Press **[menu/set]** on the base.
- 2) Press **[select/▼]** to move the pointer to select SECURITY CODE, and then press **[menu/set]**.

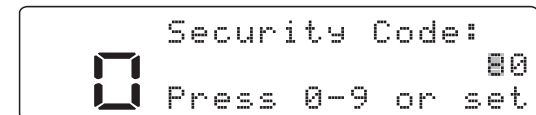

- 3) Enter a two-digit Security or PIN code (**01-99**) using the number keypad. To change the number, use [**Ø**] (delete) to backspace.
- 4) Press [**menu/set**]. You will hear a confirmation tone.

Using Your Answering Machine

The message counter on the base display will show the number of messages you have waiting. If **NEW** appears in the base display and flashes, you have new messages waiting that you have not yet listened to. The answering machine will play all of your new messages first and then play any old messages that you have not yet deleted from the system.

Turning your Answering System On & Off

Turning On	Turning Off
<ol style="list-style-type: none"> 1) With the phone in standby, press [on/off] on the base. 2) The system announces “Answering System is on” and plays the current greeting. 3) The answer on/off light will be illuminated. If the answer on/off light flashes, then you have new messages waiting. 	<ol style="list-style-type: none"> 1) With the phone in standby, press [on/off] on the base. 2) The system announces “Answering System is off”. 3) The answer on/off light will no longer be illuminated.

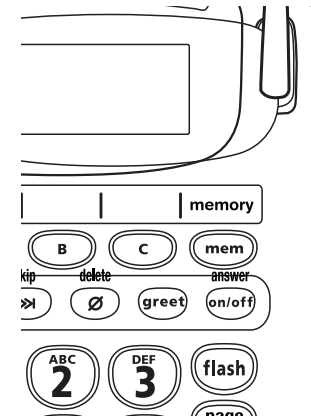

Note: When the answering machine is full, **FL** appears on the base display. You should delete some messages so that the system can record new messages.

Reviewing Messages

The base display indicates the number of messages you have waiting. When you have new messages, the **answer on/off** light on the base will flash and NEW will appear in the base display and flash. The answering machine plays your new messages first. After you listen to all of your new messages, you can then play your old messages.

To review your messages from the base:

Playing messages	With the phone in standby, press [▶/□] (play/stop). The system announces the number of new and old messages. It announces the message number, plays the message, then announces the time and date it was received.
Repeating a message	Press [<<] (repeat/rewind) once to go to the beginning of the current message. Press [<<] (repeat/rewind) repeatedly to go back to a previous message. Press and hold [<<] (repeat/rewind) to rewind through the current message.
Skipping a message	Press [>>] (skip/forward) to go to the beginning of the next message. Press and hold [>>] (skip/forward) to fast forward through the current message.
Deleting a message	While a message is playing, press [∅] (delete). The message is permanently deleted.
Deleting all messages	While the phone is in standby, press [∅] (delete). When the system asks you to confirm, press [∅] (delete) again. All messages are permanently deleted.
Ending the message review	Press [▶/□] (play/stop) at any time to stop the message playback and return to standby. The message counter shows the number of messages stored in memory.

Note: You can not delete unheard messages. If you try to delete messages before listening to them, the answering machine will beep and say “Please playback all messages.”

Screening Calls

Your phone allows you to listen to callers leaving a message without answering the phone. You can always hear callers from the base speaker. To screen an incoming call, make sure your phone has Call Screening activated. To activate this feature, please see page 44.

- To adjust the volume, press **[select/▲]** or **[select/▼]** on the base.
- To answer the call, pick up the corded handset or press **[talk]** on the base.
- To mute the Call Screen, press **[▶/□]** (play/stop).
- To cancel muting, press **[select/▲]** or **[select/▼]**.
- If you turn the answering system off, you cannot screen a call.

Remotely Operating Your Answering Machine

You can access your answering machine while you are away from home to check, play, delete messages or even record a new greeting or turn your answering machine on and off. Once you enter the remote access menu, you must enter a command within 15 seconds, or the system automatically hangs up and returns to standby. For your convenience remote operation cards, located on page 62, are provided for you to use while away from home.

To remotely operate your answering machine from any touch-tone telephone:

- 1) Call your telephone number.
- 2) During the greeting, press **[#]** and enter your PIN code (see *Setting a Security Code or Personal Identification Number (PIN)* on page 47).
- 3) The system announces the current time and the number of messages stored in memory. Then you hear “To play incoming messages, press pound two. For help, press pound zero.”

4) You may continue to listen to the voice prompts, or you may select a command from the following chart:

Command	Function	Command	Function
[#] then [1]	Repeat a Message	[#] then [6]	Answering System On
[#] then [2]	Play incoming Messages	[#] then [7]	Memo Record/Stop*
[#] then [3]	Skip a Message	[#] then [8]	Greeting Message Record/Stop*
[#] then [4]	Delete a Message	[#] then [9]	Answering System Off
[#] then [5]	Stop Operation	[#] then [0]	Voice Prompts

* For Memo Record and Greeting Message Record, the first time you enter the corresponding command, it starts the recording automatically. If you want to stop the recording, enter the command again.

- 5) After all of the voice prompts have been played, you will hear intermittent beeps indicating that the system is in the command waiting mode. You may enter another command at this time from the chart.
- 6) When you are finished, hang up to exit. The system automatically returns to standby.

Note:

- If you enter an incorrect security code three times, you will hear a beep and the system will return to standby.
- The voice memo messages are recorded as incoming messages.
- When the answering system is full, you cannot record a voice memo message until you clear some messages from the memory.

Maintenance Specifications

Operation Temperature	-10°C to +50°C (+14°F to +122°F)		
AC Adapter		For the Base	For the Charger
	Part Number	AAD-065S(M)	AAD-600S(M)
	Input Voltage	240V AC, 50Hz	240V AC, 50Hz
	Output Voltage	9V DC @500mA	9V DC @210mA
Handset Battery	Part Number	BT-905S	
	Capacity	500mAh, 3.6V DC	

Note: To avoid damage to the phone use only Uniden AAD-065S(M), AAD-600S(M) and BT-905S with your phone.

Power Failure

During a power failure, you can make and receive calls with the base corded handset; however, you will not be able to use the base speakerphone or the cordless handset. The following features are available with the base corded handset during a power failure:

- Corded Volume Control
- Emergency Key
- 3 One-touch dial Keys
- Redial
- Pause
- Flash
- A special ring tone will sound during a power failure and you will not be able to control the volume setting of this ring.

Battery Life

With average use, your battery talk time will be approximately 6 hours and standby time will be approximately 6 days. For optimum performance, be sure to return the cordless handset to the charging cradle after each call. If the cordless handset is left off of the charger, the actual talk time duration will be reduced respective to the amount of time the handset is off the cradle.

Note: Do not place the power cord where it creates a trip hazard or where it could become chafed and create a fire or electrical hazard.

Low battery alert

When the battery pack is very low, the cordless handset is programmed to eliminate functions in order to save power. The battery pack needs to be charged when the cordless handset shows LOW BATTERY CHARGE HANDSET. None of the cordless handset keys will operate until the cordless handset is fully charged. If you are on a call and LOW BATTERY appears, complete your conversation as quickly as possible, and return the handset to the charger.



Low Battery
Charge Handset

Battery Replacement and Handling

With normal use, your cordless phone's battery should last approximately one year. To order replacement batteries or adapters, please see inside back cover or visit www.uniden.com.au for Australian model or www.uniden.co.nz for New Zealand model for contact information.

Note: When replacing batteries, the information stored in the phone's memory will only be retained for 30 minutes after the battery pack is removed. This includes volume, ringer tone and last number dialed. You will want to replace the battery as quickly as possible in order to avoid losing your cordless handset settings.

[53]

Warning: To avoid the risk of personal injury or property damage from fire or electrical shock, only use the Uniden battery model and Uniden adapter model specifically designated for this product.

Caution:

- Use only the specified Uniden battery pack (BT-905S).
- Do not remove the batteries from the handset to charge it.
- Never throw the battery into a fire, disassemble, or heat it.
- Do not remove or damage the battery casing.

Installing the Rechargeable Battery for Cordless Handset

- 1) Press down on the cordless handset battery case cover (use the finger indentation for a better grip) and slide the cover downward to remove.
- 2) Plug the battery pack connector (red & black wires) into the jack inside the battery compartment. (The connector notches fit into the grooves of the jack only one way.) Match the wire colors to the polarity label in the battery compartment, connect the battery and listen for a click to insure connection.
- 3) Make sure you have a good connection by slightly pulling on the battery wires. If the connection is secure, the battery jack will remain in place.
- 4) Place the battery case cover back on the handset and slide it upwards until it clicks into place.

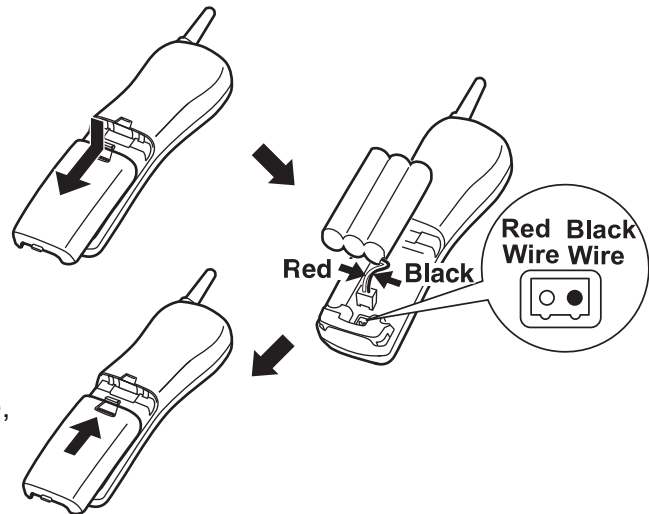

Note: Use only the Uniden BT-905S rechargeable battery pack supplied with your cordless telephone.

Cleaning the Battery Charging Contacts

To maintain a good charge, clean the charging contacts on both the cordless handset and charger once a month. Dampen a cloth with plain water. Gently rub the damp cloth over the charging contacts until all visible dirt is removed. Dry the contacts thoroughly before returning the handset to the cradle.

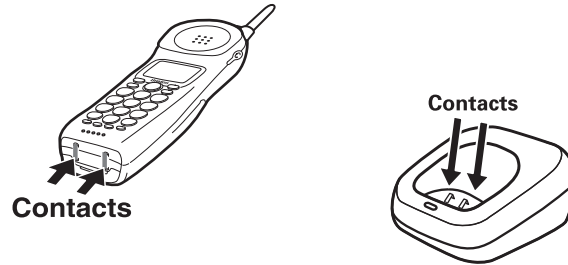

Caution:

Do not use paint thinner, alcohol, or other chemical products.

Doing so may discolor the surface of the telephone and damage the finish.

Troubleshooting

Traveling Out of Range

During a call, if you move your cordless handset too far away from your base, noise may increase. If you pass the range limits of the base, your call will terminate within one minute.

Common Issues

If your phone is not performing to your expectations, please try these simple steps first. If these steps do not solve your problem, please call our Customer Service Hotline. Please see inside the back cover for contact information.

Symptom	Suggestion
The charge light won't illuminate when the cordless handset is placed in the cradle.	<ul style="list-style-type: none">• Make sure the AC adapter is plugged into the cradle and wall outlet.• Make sure the cordless handset is properly seated in the cradle.• Make sure the charging contacts on the cordless handset and charger are clean.
The audio sounds weak and/or scratchy.	<ul style="list-style-type: none">• Move the handset and/or base away from metal objects or appliances and try again.• Press [delete/channel] during a call to help eliminate background noise.• Make sure that the cordless handset is not too far from the base.
Can't make or receive calls.	<ul style="list-style-type: none">• Check both ends of the telephone cord.• Make sure the AC adapter is plugged into the base and wall outlet.• Disconnect the AC adapter for a few minutes. Then reconnect it.• Make sure that the cordless handset is not too far from the base.• Check the dialing mode used by your telephone company.

Symptom	Suggestion
During power failure, can't make or receive a call.	<ul style="list-style-type: none"> • Make sure to use corded handset to make or receive a call. • Make sure that telephone cord is firmly connected.
The cordless handset doesn't ring or receive an intercom page.	<ul style="list-style-type: none"> • The battery pack may be weak. Charge the battery for 15-20 hours. • The cordless handset may be too far from the base unit. • Place the base unit away from appliances or metal objects. • Check the battery pack to ensure there is a secure connection. • Make sure ringer volume is not set to off.
Severe noise interference.	<ul style="list-style-type: none"> • Keep the handset away from microwave ovens, computers, remote control toys, wireless microphones, alarm systems, intercoms, room monitors, fluorescent lights, and electrical appliances. • Move the base to another location or turn off the source of interference.
The Caller ID does not display.	<ul style="list-style-type: none"> • The call was answered before the second ring. • The call was placed through a switchboard. • Your Caller ID service may not be active; contact your local telephone service provider.
The answering machine does not work.	<ul style="list-style-type: none"> • Make sure the AC adapter is plugged into a wall outlet. • Make sure the answering machine is turned on.
The answering machine does not record any messages.	<ul style="list-style-type: none"> • Set the record time to either the one minute or four minutes option. • The memory may be full. Delete some or all of the saved messages.

Symptom	Suggestion
Messages are incomplete.	<ul style="list-style-type: none"> • The incoming messages may be too long. Remind callers to leave a brief message. • The memory may be full. Delete some or all of the saved messages.
After a power failure, the outgoing message is deleted.	<ul style="list-style-type: none"> • Record your personal outgoing message again. The default message should remain.
No sound on the base speaker during call monitoring or message playback.	<ul style="list-style-type: none"> • Adjust the speaker volume on the base. • Make sure the call screen feature is set to on.
Cannot access remote call-in features from another touch tone phone.	<ul style="list-style-type: none"> • Make sure you are using the correct PIN code. • Make sure that the touch-tone phone you're using can transmit the tone for at least two seconds. If it cannot, you may have to use another phone to access your phone.
CID Announce feature is not announcing new incoming calls.	<ul style="list-style-type: none"> • Check to make sure the CID Announce switch on the back of the base is set to ON. • Check your base speaker volume to ensure it is loud enough to hear the CID Announce feature.

Liquid Damage

Moisture and liquid can damage your cordless phone.

- If the handset or base is exposed to moisture or liquid, but only the exterior plastic housing is affected, wipe off the liquid, and use as normal.
- If moisture or liquid has entered the plastic housing (i.e. liquid can be heard in the phone or liquid has entered the handset battery compartment or vent openings on the base), follow the steps below:

Cordless Handset	Base
<ol style="list-style-type: none">1) Remove the battery cover and leave it off for ventilation.2) Disconnect the battery pack. Leave the battery cover off and the battery pack disconnected for at least 3 days.3) Once the handset is completely dry, reconnect the battery pack and the battery cover.4) Recharge the handset's battery pack for 15 to 20 hours before using.	<ol style="list-style-type: none">1) Disconnect the AC adapter from the base, cutting off electrical power.2) Disconnect the telephone cord from the base.3) Let dry for at least 3 days.

IMPORTANT:

You must unplug the telephone line while recharging the battery packs to avoid charge interruption.

CAUTION:

DO NOT use a microwave oven to speed up the drying process. This will cause permanent damage to the handset, base and the microwave oven. After following these steps, if your cordless telephone does not work, please see inside back cover or visit www.uniden.com.au for Australian model or www.uniden.co.nz for New Zealand model for contact information.

Precautions!

Before you read anything else, please note the following:

Warning!

Uniden Australia Pty Ltd and Uniden NZ Ltd DO NOT represent this unit to be waterproof. To reduce the risk of fire, electrical shock, or damage to the unit, DO NOT expose this unit to rain or moisture.

Rechargeable Nickel-Cadmium Battery

Warning

- This equipment contains a rechargeable nickel-cadmium battery.
- The rechargeable nickel-cadmium battery contained in this equipment may explode if disposed of in a fire.
- Do not short-circuit the battery.
- Do not charge the rechargeable nickel-cadmium battery used in this equipment in any charger other than the one designed to charge this battery as specified in the owner's manual. Using another charger may damage the battery or cause the battery to explode.



The exclamation point within an equilateral triangle is intended to alert the user to the presence of important operating and maintenance (servicing) instructions in the literature accompanying the appliance.

Uniden works to reduce lead content in our PVC coated cords in our products and accessories.

Important Safety Instructions

When using your telephone equipment, basic safety precautions should always be followed to reduce the risk of fire, electric shock and injury to persons, including the following:

1. Do not use this product near water, for example, near a bath tub, wash bowl, kitchen sink or laundry tub, in a wet basement or near a swimming pool.
2. Avoid using a telephone (other than a cordless type) during an electrical storm. There may be a remote risk of electric shock from lightning.

Index

- A**
 - AC adapter information 52
 - Answering machine
 - Remote operation 50
 - Reviewing messages 49
 - Setup 43
 - Turning on & off 48
 - Audio boost 34
- B**
 - Battery pack
 - Information 52
 - Installing 54
 - Replacement and handling 53
 - Beltclip installation 18
- C**
 - Caller ID service 39
 - Call waiting 31
 - Deleting 41
 - Making a call 31
 - Viewing 40
 - Channel 35
 - Charging a battery pack 17
 - Cleaning contacts 55
 - Clock 19
 - Connect the base unit 12
 - Connect the cradle 17
- D, E, F, G, H**
 - Earpiece volume 33
 - Emergency dial 22, 30
 - Finding the lost handset 35
 - Greeting 46, 47
 - Headset installation 18
- I, J, K, L**
 - Insert 0 20
 - Installing the phone 11
 - Intercom 37
 - Liquid damage 59
- M, N, O, P, Q**
 - Maintenance 52
 - Making a call 29
 - Message alert 45
 - Name Tag 20
 - One-touch speed dial (Base) 23
 - Personal identification number (PIN) 47
 - Power failure 28, 52
 - Precautions 60
 - Product overview 5
- R**
 - Receiving a call 29
 - Record time 44
 - Redial 32
 - Remote operation 50
- Reviewing messages 49
- Ring time 45
- Ringer tone and volume 33
- S**
 - Screening calls 44, 50
 - Setting Caller ID on Call Waiting (CIDCW) 21
 - Setup
 - Answering machine 43
 - Base 19
 - Handset 21
 - Speaker volume 33
 - Specifications 52
 - Speed dial memory
 - Making calls 30
 - One-touch speed dial (Base) 23
 - Storing names and numbers .. 24
- T, U**
 - Transferring a call 38
 - Traveling out of range 56
 - Troubleshooting 56
- V, W, X, Y, Z**
 - Visual ringer 14
 - Wall mounting 15
 - Warranty 66

Remote Operation Card

C U T

REMOTE OPERATION CARD



Remote access away from home Turn on the answering system remotely

- | | |
|---|--|
| <ol style="list-style-type: none"> 1. Call your phone number from a touch-tone phone. 2. During the outgoing message, press [#] and enter your PIN code. The answering system announces the number of messages stored in memory and the voice prompts. The phone stands by for you to enter a command. 3. To quit, hang up the phone. | <ol style="list-style-type: none"> 1. Call your phone and let it ring 15 times until it answers. 2. Press [#] and enter your PIN code. 3. Press [#] then [5] to stop the announcement. 4. Press [#] then [6] to turn the answering system on. |
|---|--|

C U T

REMOTE OPERATION CARD



Remote access away from home Turn on the answering system remotely

- | | |
|---|--|
| <ol style="list-style-type: none"> 1. Call your phone number from a touch-tone phone. 2. During the outgoing message, press [#] and enter your PIN code. The answering system announces the number of messages stored in memory and the voice prompts. The phone stands by for you to enter a command. 3. To quit, hang up the phone. | <ol style="list-style-type: none"> 1. Call your phone and let it ring 15 times until it answers. 2. Press [#] and enter your PIN code. 3. Press [#] then [5] to stop the announcement. 4. Press [#] then [6] to turn the answering system on. |
|---|--|

C U T

MEMORY LOCATION MEMO

Memory Location	Name	Phone Number
1		
2		
3		
4		
5		

C U T

MEMORY LOCATION MEMO

Memory Location	Name	Phone Number
1		
2		
3		
4		
5		

Remote Operation Card

C U T

MEMORY LOCATION MEMO

Memory Location	Name	Phone Number
6		
7		
8		
9		
10		

C U T

MEMORY LOCATION MEMO

Memory Location	Name	Phone Number
6		
7		
8		
9		
10		

C U T

Task	Key
Repeat a Message	# ①
Play Incoming Messages	# ②
Skip a Message	# ③
Delete a Message	# ④
Stop Operation	# ⑤
Answering System On	# ⑥
Memo Record/Stop	# ⑦
Greeting Message Record/Stop	# ⑧
Answering System Off	# ⑨
Voice Prompts	# ⑩

C U T

Task	Key
Repeat a Message	# ①
Play Incoming Messages	# ②
Skip a Message	# ③
Delete a Message	# ④
Stop Operation	# ⑤
Answering System On	# ⑥
Memo Record/Stop	# ⑦
Greeting Message Record/Stop	# ⑧
Answering System Off	# ⑨
Voice Prompts	# ⑩

Memo

Memo

[65]

ONE YEAR LIMITED WARRANTY

UNIDEN SSE17+1

IMPORTANT :

Evidence of original purchase is required for warranty service.

WARRANTOR :

Uniden Australia Pty Limited
A.B.N. 58 001 865 498
Uniden New Zealand Limited

Warranty only available in original country of

purchase.

ELEMENT OF WARRANTY :

Uniden warrants to the original retail owner for the duration of this warranty, its SSE17+1 (herein after referred to as the Product), to be free from defects in materials and craftsmanship with only the limitations or exclusions set out below.

WARRANTY DURATION:

This warranty to the original retail owner only, shall terminate and be of no further effect ONE (1) year after the date of original retail sale. This warranty will be deemed invalid if the Product is;

- (A) Damaged or not maintained as reasonable and necessary,
- (B) Modified, altered or used as part of any conversion kits, subassemblies, or any configurations not sold by Uniden,
- (C) Improperly installed,
- (D) Repaired by someone other than an authorized Uniden Repair Agent for a defect or malfunction covered by this warranty,
- (E) Used in conjunction with any equipment or parts or as part of a system not manufactured by Uniden, or
- (F) Where the Serial Number label of the product has been removed or damaged beyond recognition.

Warranty only valid in the country of original retail/sale.

PARTS COVERED:

This warranty covers for one (1) year, the Product and included accessories.

STATEMENT OF REMEDY:

In the event that the Product does not conform to this warranty at any time while this warranty is in effect, the warrantor at its discretion, will repair the defect or replace the Product and return it to you without charge for parts or service. This warranty does not provide for reimbursement or payment of incidental or consequential damages.

This EXPRESS WARRANTY is in addition to and does not in any way affect your rights under the TRADE PRACTICES ACT 1974 (Cth) (Australia) or the CONSUMER GUARANTEES ACT (New Zealand).

PROCEDURE FOR OBTAINING PERFORMANCE OR WARRANTY:

In the event that the Product does not conform to this warranty, the Product should be shipped or delivered, freight pre-paid, with evidence of original

purchase (e.g. a copy of the sales docket), to the warrantor at:

UNIDEN AUSTRALIA PTY LIMITED

SERVICE DIVISION

345 Princes Highway, Rockdale NSW 22161
Fax (02) 9599 3278
www.uniden.com.au

UNIDEN NEW ZEALAND LIMITED

SERVICE DIVISION

50 Harris Road, East Tamaki, Auckland
Fax (09) 274 4253
www.uniden.co.nz

Customers in other States should ship or deliver the Product freight pre-paid to their nearest Uniden Authorized Repair Centre (Contact Uniden for the nearest Warranty Agent to you)

Uniden®

© 2008 Uniden Australia Pty Limited/Uniden New Zealand Limited
Printed in China UPZZ01138ZZ(0)

Free Manuals Download Website

<http://myh66.com>

<http://usermanuals.us>

<http://www.somanuals.com>

<http://www.4manuals.cc>

<http://www.manual-lib.com>

<http://www.404manual.com>

<http://www.luxmanual.com>

<http://aubethermostatmanual.com>

Golf course search by state

<http://golfingnear.com>

Email search by domain

<http://emailbydomain.com>

Auto manuals search

<http://auto.somanuals.com>

TV manuals search

<http://tv.somanuals.com>