

# uniden®

UHF CB TRANSCEIVER

## OWNER'S MANUAL

### SUNDOWNER UH-100 SCANNING

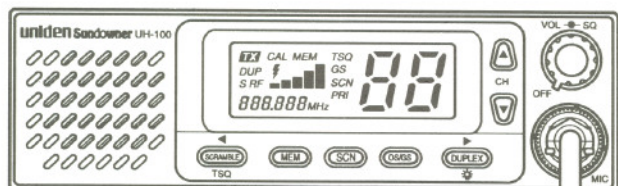

*With Audio Scrambler and  
Built-In SELCALL*

---

---

## Table of Contents

---

---

Controls / Indicators / Connectors .....	3
Controls .....	3
Indicators .....	4
Connectors .....	5
Introduction .....	6
Included with your UH-100 .....	7
Operation .....	8
Setting the Squelch .....	8
Selecting a Channel .....	9
Channel Auto Step .....	9
Transmitting .....	10
Using Repeater Channels .....	10
Scanning .....	13
Choosing a Priority Channel .....	15
Drop-Out Delay .....	15
Programming Scan Channels .....	16
Channel Seeking Operation .....	17
Voice Scrambler .....	18
LCD Backlight Level Control .....	19
Selective Calling .....	20
This is UH-100 Calling .....	21
Making a Call .....	21
Acknowledgment Tone .....	22
10 Selcall ID Memory .....	23
Transmitting ID from Memory .....	24
Receiving Call .....	25
Replying using SELCALL .....	26
Group Calling .....	28
Tone Squelch (Receiver Quieting) .....	29
Activating the Tone Squelch (Receiver Quieting) .....	30
Receiving Calls when in Quiet Mode .....	30
Tone Squelch Scanning .....	31
SELCALL Advance Programming .....	32
Radio ID Programming .....	34
Tone Period Programming .....	35
Lead-In Delay Programming .....	36
Lead-In Tone Programming .....	37
Alarm Mode Programming .....	39
Group Call Mode Programming .....	41
Caller ID Decoding .....	42

Service .....	43
Care and Maintenance.....	44
Notice .....	44
Preventive Maintenance .....	44
Troubleshooting .....	44
Memory Backup .....	44
UHF CB Channel Information .....	45
SIMPLEX Operating Mode .....	45
DUPLEX Operating Mode .....	46
Specifications .....	47
General .....	47
Measurement Conditions .....	48
Transmitter Section .....	48
Receiver Section .....	48
SELCALL .....	49
Warranty .....	50

# Controls / Indicators / Connectors

## Controls

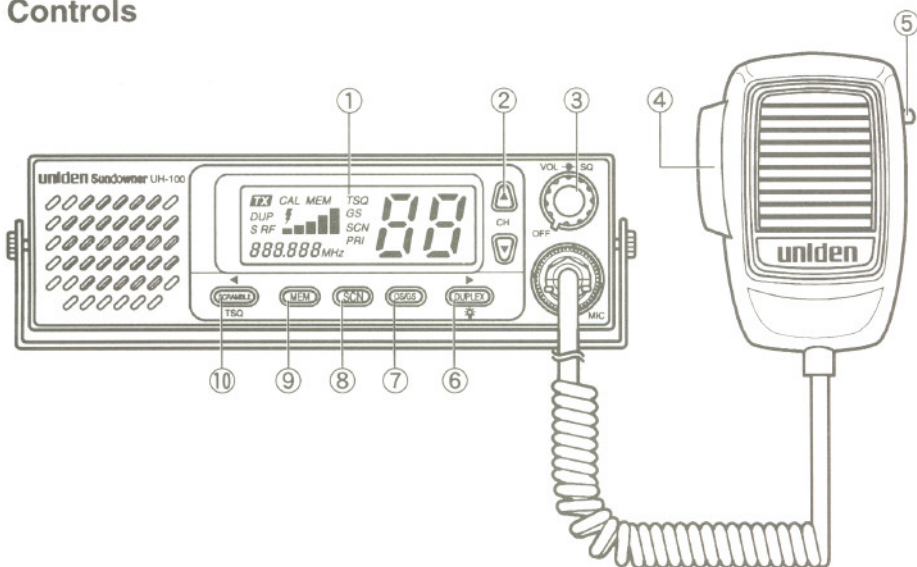

- 1. LIQUID CRYSTAL DISPLAY (LCD) PANEL** - Indicators for TX, CAL, MEM, TSO, GS (OS), SCN, PRI, Channel Number, Frequency (SELCALL Code), Signal Strength Level (S), Transmit Power Level (RF), DUP and Scrambler.
- 2. UP/DOWN CHANNEL SELECTOR** - These controls are used to select the desired communication channel.
- 3. ON/OFF, VOLUME & SQUELCH CONTROLS**  
**ON/OFF & Volume Control (Centre Knob)**  
Turns the UH-100 power ON or OFF and adjusts the volume.  
**Squelch Control (Outer Ring)**  
Eliminates background noise in the absence of an incoming signal.
- 4. PUSH-TO-TALK (PTT) SWITCH** - Press to transmit and release to receive.
- 5. TONE CALL CONTROL BUTTON** - Press to transmit SELCALL codes, also used to access TX SELCALL ID programming.
- 6. DUPLEX / LCD BACKLIGHT Control**
  - a. Duplex Operation**  
Press this button momentarily to choose semi-duplex operation for Channels 1 through 8.
  - b. LCD Backlight Control**  
Press and hold this button to change the LCD backlight level BRIGHT - DIM - OFF.
- 7. OPEN SCAN/GROUP SCAN CONTROL (OS/GS)** - Switches operation between OPEN SCAN and GROUP SCAN Mode.

8. **SCAN CONTROL (SCN)** - Press to activate Normal OS/GS scanning or press and hold to enable Seek Mode OS/GS Scanning.
9. **MEMORY CONTROL (MEM)** - Places channel numbers into the memory scan list (OS or GS).
10. **AUDIO SCRAMBLER / TONE SQUELCH CONTROL** - Controls access to audio scrambling feature and Tone Squelched operation (Quiet Mode).

## Indicators

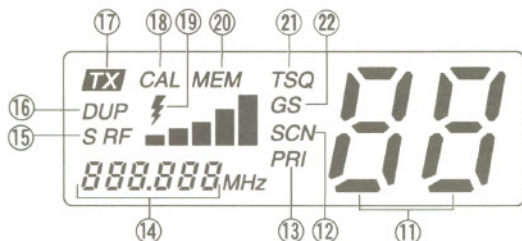

11. **Channel Indicator** - Indicates the channel number currently selected. On TX SELCALL usage the Channel Indicator becomes a Memory location indicator.
12. **Scan Indicator (SCN)** - SCN icon appears when Normal Scan mode is activated. When Seek Mode Scanning is selected the SCN icon blinks.
13. **Priority Indicator (PRI)** - Indicates that Priority channel is active when continuously lit or Flashes when it is regularly being checked for activity while GS scanning.
14. **Frequency / SELCALL ID Indicator** - Shows the frequency of the current selected channel. The Frequency Indicator changes to SELCALL ID display when using the SELCALL feature.
15. **RECEIVE SIGNAL / RF LEVEL Indicator (S / RF)** - Indicates the relative signal strength level when receiving (S) or the relative transmit power (RF) when transmitting.
16. **DUPLEX Indicator (DUP)** - The DUP icon appears when duplex operation is selected.
17. **TRANSMIT Indicator (TX)** - TX appears when the PTT button on the microphone is pressed and the radio is transmitting. The RF icon also appears at this time.
18. **CALL Indicator (CAL)** - The CAL icon appears when the UH-100 radio is called using SELCALL. It also appears when SELCALL codes are being transmitted.
19. **SCRAMBLER Indicator (ƒ)** - The ƒ icon appears when the Voice scrambler is activated.
20. **MEMORY Indicator (MEM)** - MEM appears when the displayed channel is programmed either in GS or OS Memory.
21. **TONE SQUELCH Indicator (TSQ)** - The TSQ icon will appear when the selected channel is set to operate in Quiet Mode, or flashes when the radio is called using SELCALL.
22. **GROUP SCAN Indicator (GS)** - The GS icon appears when Group Scan Mode is activated. Open Scan is indicated by the absence of the GS icon.

# Connectors

## Front Panel

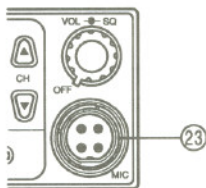

### 23. MICROPHONE SOCKET

The microphone plug is inserted into this socket.

## Back Panel

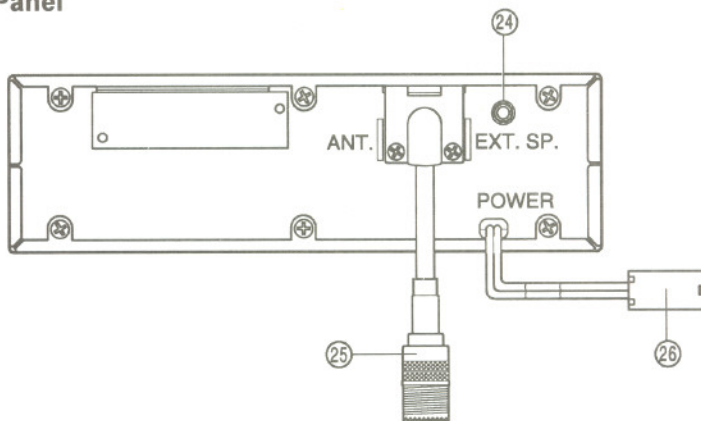

**24. EXTERNAL SPEAKER JACK** - Used for remote receiver monitoring. When the external speaker is connected, the internal speaker is automatically disconnected. The connecting wire must use a 3.5mm miniature plug only.

**25. ANTENNA CONNECTOR** - Connect the Antenna here using a PL259 type connector.

**26. DC POWER CORD** - DC power is connected to the transceiver through this jack. A power cord is supplied with the transceiver.

---

---

# Introduction

---

---

The Uniden UH-100 UHF two way radio is designed to provide you with years of trouble free service. Its rugged components and materials are capable of withstanding harsh environments. The unit may be mounted in several convenient locations using the universal mounting bracket.

You can be confident in your choice of radio equipment because the UH-100 offers built-in SELCALL, Wide Liquid Crystal Display, Back-lit Control buttons, complete coverage of the UHF CB Frequency Band, and much more.

We are certain that you will enjoy your UH-100. Please read this operating guide carefully to ensure you gain the optimum performance of the unit.

## General Features

- Full Coverage of the UHF CB Band
- 5 Watt Max. Transmitter
- Built - In SELCALL Feature
- External Speaker Jack
- Full Frequency Display
- Wide Liquid Crystal Display
- Back-lit Control Buttons
- Multi LCD Backlight Level
- Duplex Capability
- Built-In Voice Scrambler
- Open Scanning
- Group Scanning / Priority Channel Monitoring
- Channel Seek Mode
- Push Button Channel Control
- Front Fire Speaker

## SELCALL Features

- 10 TX SELCALL ID Memory Locations
- User Programmable
- Caller Identification
- Full ID Display
- Last ID Re-SEND
- Return Call
- Acknowledge Tone
- Tone Squelch Mode (Receiver Quieting)
- Tone Squelched Scanning
- Compatible with most SELCALL equipped radios in the market.

Specifications, features, and availability of optional Accessories are all subject to change without prior notice.

---

## Included with your UH-100

---

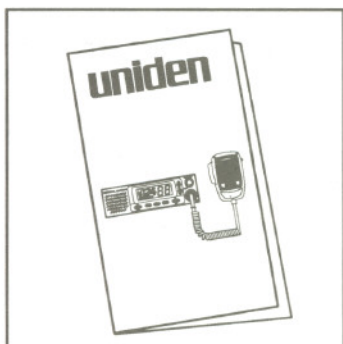

UH-100 Owner's Manual

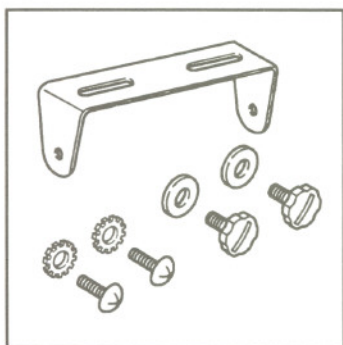

Mounting Bracket, Knobs,  
Rubber Washer, Washer Stars  
and Screws



Warranty Registration Sheet

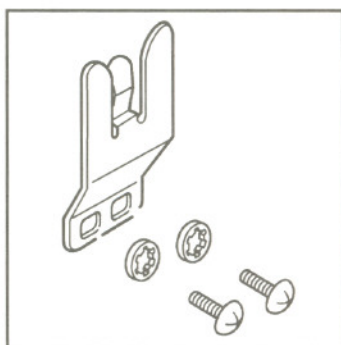

Microphone Hanger, Screws  
and Washers

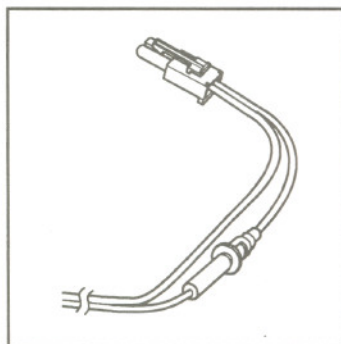

DC Power Cord with Fuse



# Operation

## Setting the Squelch

1. To turn the unit **ON**, rotate **VOLUME** clockwise.  
Adjust volume to a comfortable level.

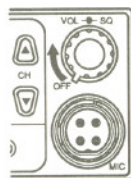

**Note:** You must select a channel which is not in use before setting the SQUELCH control on your radio.

2. Think of the Squelch control as a gate. If you turn SQUELCH fully clockwise it raises the "Squelch Gate" so high that no signals get through.

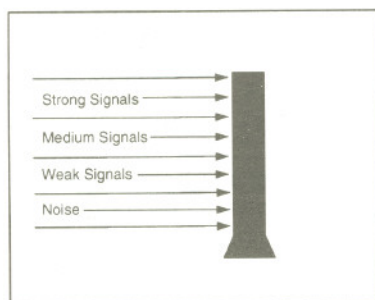
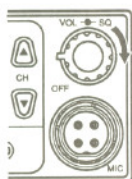

3. If you turn the SQUELCH fully counterclockwise it lowers the "Squelch Gate" so that everything gets through - noise, weak signals, and strong signals.

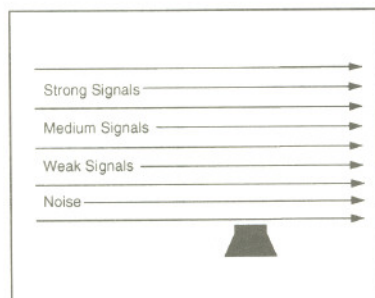
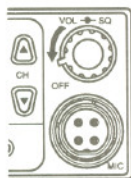

4. To set the "Squelch Gate" to the desired level, turn SQUELCH counterclockwise until you hear noise. Then turn the SQUELCH clockwise just until the noise stops. Now only strong signals get through.

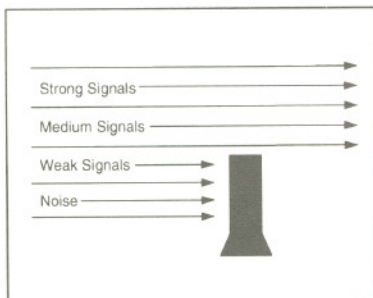
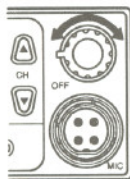

## Selecting a Channel

1. When you turn on the UH-100, the last channel used will appear on the LCD display.  
eg. CH01

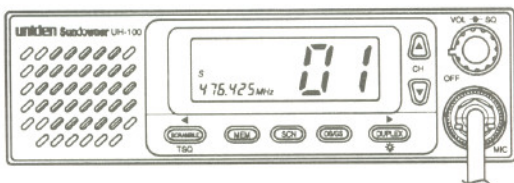

- 2a. Press ▲ to select a higher channel.

- OR -

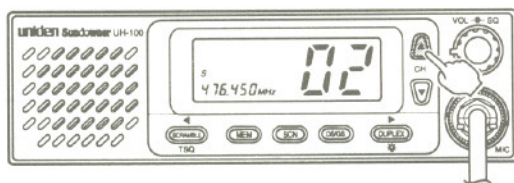

- 2b. Press ▼ to select a lower channel.

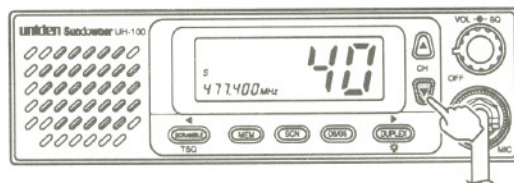

## Channel Auto Step

To quickly change channels, press and hold ▼ or ▲. This changes channels at 10 channels per second.

**Note:** A short tone sounds when you press either ▼ or ▲ and the channel changes. Another tone sounds when Channel Auto step begins.

## Transmitting

The UH-100 transmits on 40 UHF CB channels. For your reference, a listing of all the available channels is printed on the back cover.

1. Select the desired channel.

eg. CH01



2. To transmit, press the **PTT** switch to activate the transmitter.

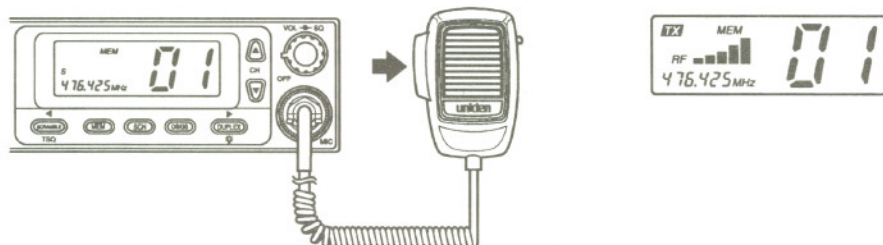

**Note:** Hold the microphone 2-4 inches from your mouth and slightly to one side so that your voice does not project directly into the microphone. Speak at a normal voice level. Never raise your voice or shout into the microphone.

3. Release the **PTT** Switch, to end the transmission and listen for the reply.



## Using Repeater Channels

UHF CB Repeaters are used to retransmit or relay your signal. Repeaters will extend the range of your radio and overcome the shielding effect caused by solid obstructions.

In normal Simplex operation, your radio transmits on one particular frequency and receives on that same frequency. If there is a barrier (i.e. valley) that partially blocks your transmitted signal, the probability of another radio receiving the signal is very slim. Valleys, tall buildings, metallic structures, ... etc. tend to act as a screen between radios.

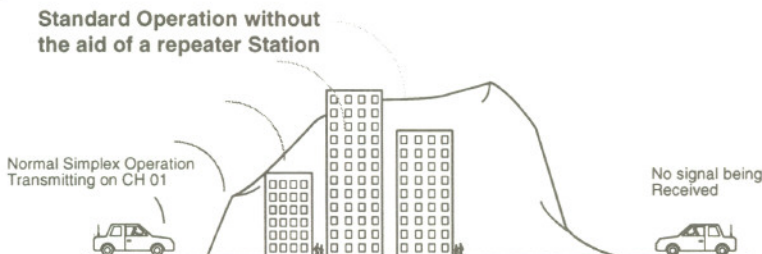

## Operation with the aid of a repeater

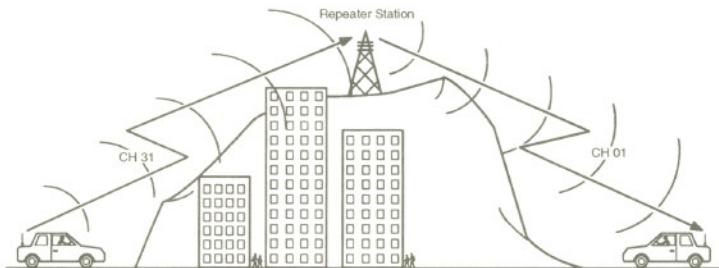

The Signal coming from your radio is received by the Repeater Station and then re-transmitted at the same time on another channel. This operation is called "Duplexing".

Your UH-100 is designed with the capability to access and use repeater stations.

Channels 01 through 08 have the option to operate in Duplex Mode. When any of these channels are set to operate in duplex mode during transmission, the UH-100 automatically sends the signal at a frequency 30 channels above the original. After transmitting, the radio reverts back to its original operating frequency.

For example,

CH01 on Duplex Mode will Receive on CH 01 but Transmit on CH31

CH02 on Duplex Mode will Receive on CH 02 but Transmit on CH32 etc....

If you transmit on CH01 Duplex mode, you are actually transmitting on CH31, the repeater station down-converts your signal and retransmits on CH01.

## To operate UH-100 in Duplex Mode,

eg. CH01 is being used in your area for repeater use.

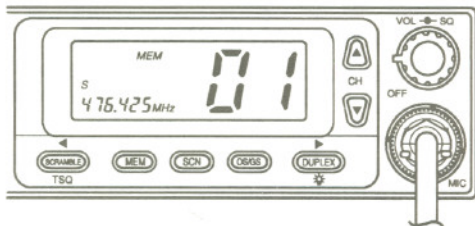

Press **DUPLEX** momentarily.  
The **DUP** icon appears.

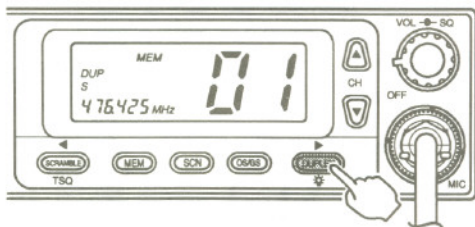

Whenever you press the **PTT** Switch the UH-100 frequency display changes to CH31 frequency.

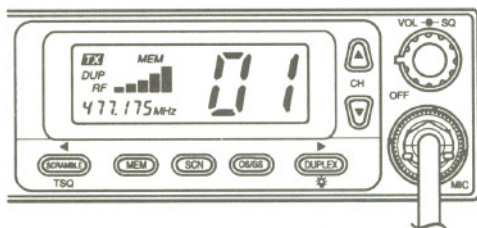

Press **DUPLEX** again to deactivate the Duplex Operation. UH-100 will return to Simplex operation.

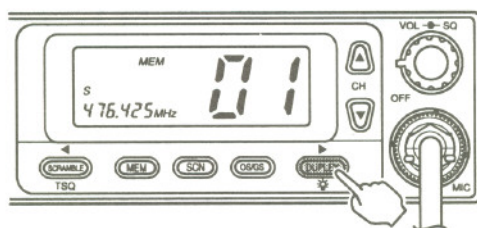

## Scanning

The UH-100 has a scanning feature that allows you to search for active channels automatically.

Furthermore, the UH-100 is designed to have two types of scanning; Open Scanning (OS) and Group Scanning (GS), to give you flexibility and allow you to use the radio more effectively.

To initiate scanning.

1. Assuming the unit is on CH17 when switched on.

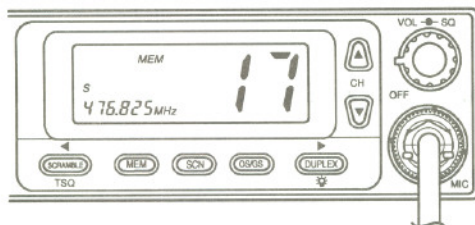

2. Press **SCN** and Scanning starts.

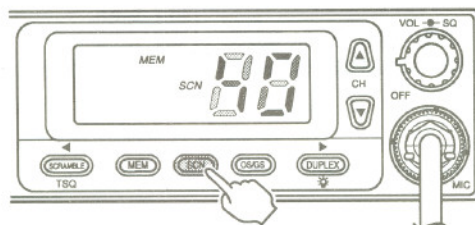

### 1. Open Scan (OS) Mode

Allows continuous scanning of channels stored in the Open Scan memory. If an active channel is found, scanning will stop on that channel.

Example. CH40 becomes active.

If the received signal ceases, the unit will wait for at least 3 seconds for the signal to return, otherwise scanning resumes.

To skip the active channel, press **MEM** momentarily. Scanning resumes.



To deactivate SCAN, press the **SCN** switch or the **PTT** Button.

**Note:** If SCAN is deactivated while in an active channel, the UH-100 will stay on that active channel. If no other channels are active, the UH-100 will reinstate the starting channel.

## 2. Group Scan (GS) Mode

Allows you to monitor a Priority Channel while scanning.

To use GS Mode Scanning, press the **OS / GS** key.

**GS** icon appears on the display. OS Mode is indicated by the absence of the **GS** icon.

GS Scanning checks the Priority channel activity regularly.

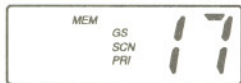

If the Priority channel becomes active the radio will stay on that channel for as long as the signal is present. If the received signal ceases, Priority scanning continues after 3 seconds.

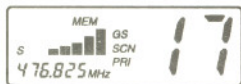

If scanning stops on a channel which is not a Priority Channel, UH-100 will continue monitoring the Priority Channel for activity while listening to the active one.

eg. CH40 becomes active.

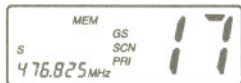

To deactivate SCAN, press the **SCN** key or the **PTT** Switch.

**Note:** If SCAN is deactivated while it is tuned at an active channel, the UH-100 will stay on that active channel. If none of the channels are active, the UH-100 will reinstate the Priority channel.

If GS Scanning is initiated when there are no channels programmed in GS memory, an error tone will be heard and scanning will not start.

## Choosing a Priority Channel

The starting channel, when Group Scanning is initiated, is always the Priority Channel.

Changing the PRI channel setting while scanning,

eg. PRI Channel is CH17 (476.825 MHz)

- a. press ▲ , to select a higher channel (scanning pauses)

- or -

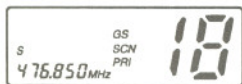

- b. press ▼ , to select a lower channel

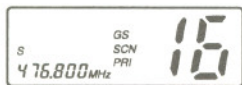

## Drop-Out Delay

While scanning, the UH-100 stops at a busy channel and receives a transmission. When the received signal is over, the unit will wait for three seconds for the return of the signal, otherwise, the radio resumes scanning.



## Programming Scan Channels

1. Select which Scanning Mode you wish to use on the channel.

OS or GS Mode

**Note:** *OS* is indicated by the absence of the **GS** icon.

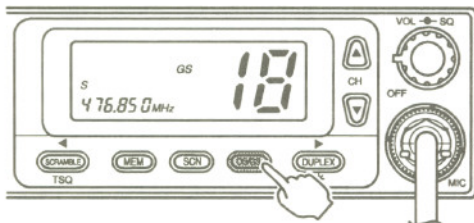

2. Select the channel you want to store.

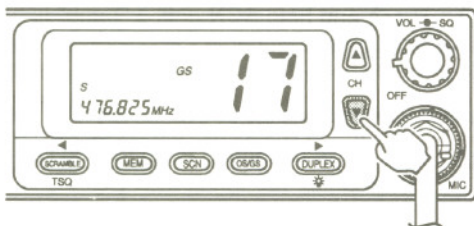

3. Press and hold **MEM** for 1.5 sec. to store. **MEM** icon appears and a short tone beep is heard.

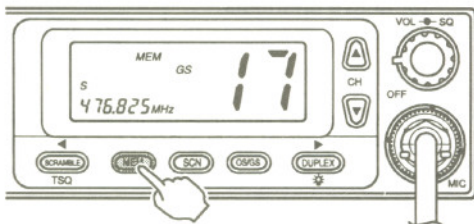

4. To remove the channel from Memory, press and hold **MEM** for 1.5 sec. once more. Two successive beeps are heard and the **MEM** icon disappears.

## Channel Seeking Operation

Unlike normal scanning, CHANNEL SEEK is used more often when checking for active channels.

If a signal is detected, while seeking, the UH-100 will tune to that signal for 4 seconds only and then resumes Seeking Operation.

Changing from SCAN to SEEK Mode operation.

1. Firstly, activate SCAN mode.



2. Press and hold **SCN** until a "beep" is heard. The **SCN** icon starts to flash.



3. If an active channel is detected the UH-100 will stop on that channel for 4 seconds. (eg. CH17)



4. After 4 seconds, the UH-100 will start seeking again for active channels.



5. If you find the channel interesting, simply press either the **PTT** switch or the **SCN** key to stop the operation before the 4 second timer elapses.

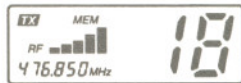

When **SCN** is pressed again SEEK is still the mode of operation.

To change back to SCAN, while SEEKING, press and hold **SCN** until a beep is heard. The **SCN** icon stops flashing.

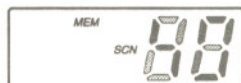

**Note:** SEEK checks the same channel stored in SCAN memory. Thus, you can Seek either in OS or GS Mode.

## Voice Scrambler

UH-100 has a built-in scrambler / de-scrambler circuit.

The Voice Scrambler feature prevents users, without the necessary descrambler equipment, "understanding" your conversation. **This feature is NOT operable on CH01 through CH08, CH31 through CH38, and CH11, and will only work between units with the voice scrambler feature compatible with the Uniden UH-100.**

To activate the audio scrambler, select an available channel for audio scrambling, eg. CH10

Press **SCRAMBLE**, the ⚡ icon appears.

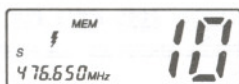

Transmit in a normal fashion.



To deactivate press **SCRAMBLE** again. The Lightning icon disappears.

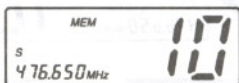

Be "Polite" when using this feature. Use this feature when the communication link is already established and only when needed.

**Note:** The Audio scrambler and the SELCALL functions cannot be operated simultaneously.

---

---

## LCD Backlight Level Control

---

---

The LCD backlight level can be changed to BRIGHT, DIM, or OFF.

To change the level simply press and hold the **DUPLEX** key for more than 1.5 seconds.

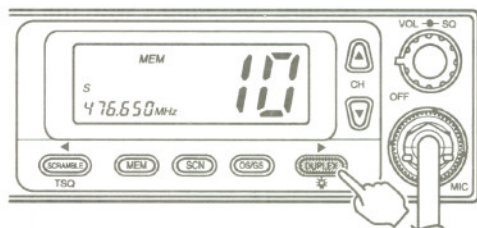

To change further, press and hold **DUPLEX** again.

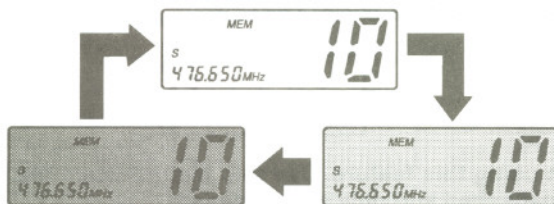

---

---

## Selective Calling

---

---

When you listen to UHF CB you will hear all the conversations going on, which can become annoying at times. Ideally you need a system that alerts you when the signal is from someone you wish to communicate with.

You want your radio to be SELECTIVE about the people you talk to!

That's what the Uniden UH-100 offers, with SELECTIVE CALLING, commonly known as SELCALL. It lets you know that the people you want to talk to are calling.

To achieve this each radio must have a SELCALL ID.

This SELCALL ID acts as a "Phone Number" and your radio as a "Mobile Phone". Everybody in your group must have a different "Phone Number" that only your group members should know. If one of your members dials your "Phone Number", when reached successfully, your "Mobile Phone" of course will "Ring", and your caller will hear a "Ringing Tone".

This "Ring" is actually a CALL Alarm, and the "Ringing Tone" is an Acknowledgment Tone. Any user tuned to your UHF CB channel will hear the conversation.

### UH-100 Selcall Features

- User Programmable UH-100 SELCALL ID
- 10 Transmit SELCALL ID Memory
- Full ID Display
- Caller Identification
- Acknowledgment Tone
- Auto Caller ID Load and Reply (Return Call)
- Last ID Resend
- Tone Squelched Channel Scanning
- All SELCALL Parameters are User Programmable
- Receiver Quieting (Tone Squelched Mode)

**Note:** *You only give your Selcall code to people who you want to be able to get in touch with. Likewise you need to know their Selcall codes to be able to contact them. Other users in your SELCALL family may not be using Uniden radios, the Uniden UH-100 can be programmed to have full compatibility with other brands. Please read the selcall advance programing section of this manual for guidance.*

**The Audio scrambler and the SELCALL functions cannot be operated simultaneously.**

## This is UH-100 Calling.....

The UH-100 is shipped from the factory with a SELCALL ID setting of "00000". Refer to the Advance Section on page 32 for details on how to change/customize your UH-100 Selcall ID.

### Making a Call

To make a call, press and release the **TONE CALL** switch on the microphone.

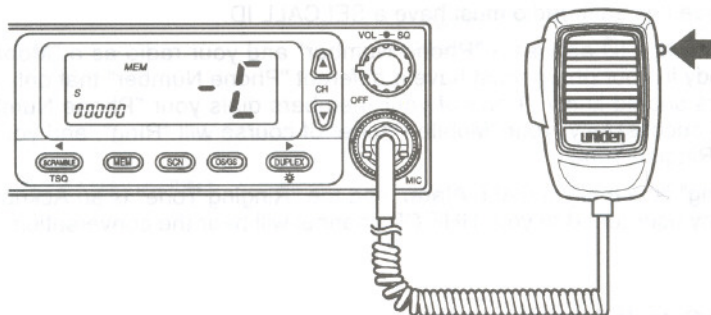

The last used Selcall ID will be displayed. (If you have never used the Selcall feature **00000** will appear.)



Press the **MEM** switch on the UH-100 and the last digit of the Selcall ID will flash. This indicates that you can now start to enter the Transmit Selcall ID code.

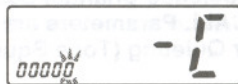

The flashing digit is the one you can program.

To select the digit you wish to change use the ◀ / **SCRAMBLE** or ▶ / **DUPLEX** to move the position.

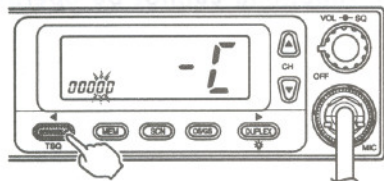

OR

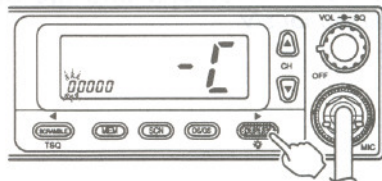

To change the flashing digit use the Channel ▲ and ▼ buttons.

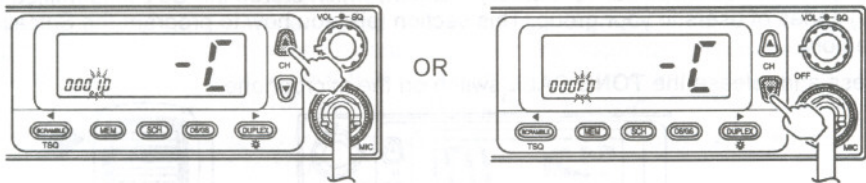

When completed, press and hold the **TONE CALL** button to send.

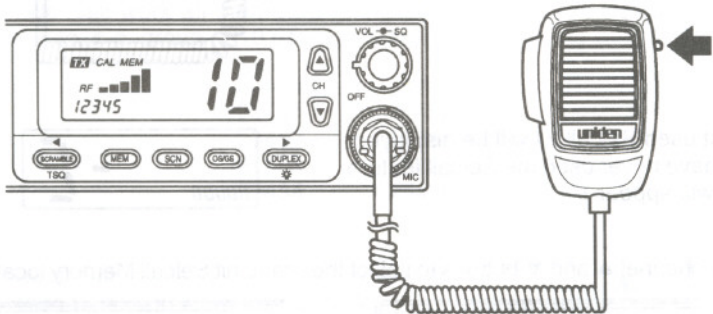

This ID will be stored in the **Last ID Transmitted** buffer. Every time the Tone call button is pressed the last ID will be shown. To transmit the ID again, simply press and hold the Tone Call button once more.

When the called radio is successfully reached an Acknowledgment Tone will be received.

## Acknowledgment Tone

The UH-100 automatically acknowledges all the Selective Calls it receives, thereby advising the caller that it has been contacted successfully.

Three low tone beeps characterise the UH-100 Acknowledgment Tone.

## 10 Selcall ID Memory

The UH-100 has a special 10 memory location, which stores the Selcall identification (ID) codes of users in your group. This section tells you how to program the Selcall ID memory.

Press and release the **TONE CALL** switch on the microphone.

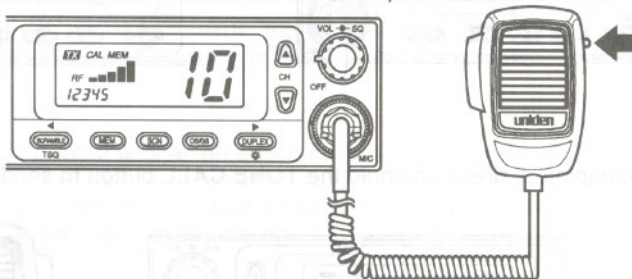

The last used Selcall ID will be displayed. (If you have never used the Selcall feature 00000 will appear.)



Use the channel **▲** and **▼** buttons to select the Transmit Selcall Memory location number.

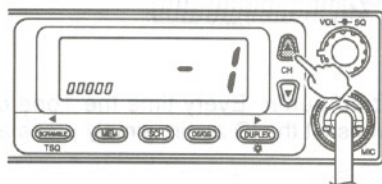

OR

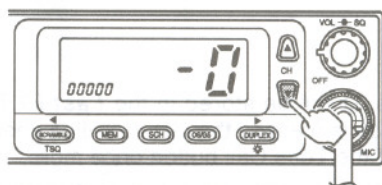

Press the **MEM** switch on the UH-100 and the last digit of the Selcall ID will flash. This indicates that you can now start to enter the Transmit Selcall ID code.



The flashing digit is the one you can program.

To select the digit you wish to change use the **◀** / **SCRAMBLE** or **▶** / **DUPLEX** to move the position.

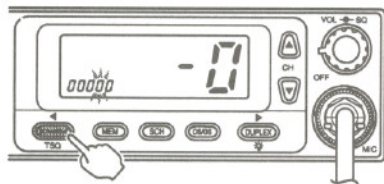

OR

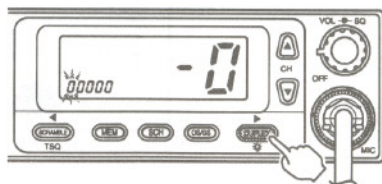



To change the flashing digit use the Channel ▲ and ▼ buttons.

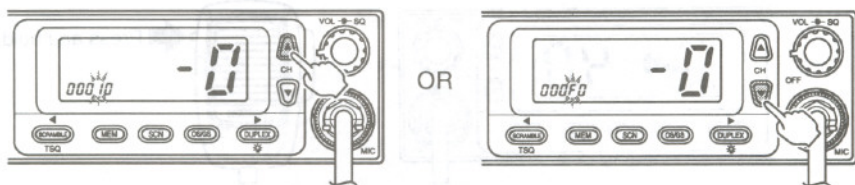

When completed, press **MEM** to store.

You repeat this process to store Transmit Selcall ID's into the remaining memory locations of your UH-100.

## Transmitting ID from Memory

The procedure is very much the same as explained in making a call.

Press the **TONE CALL** button.

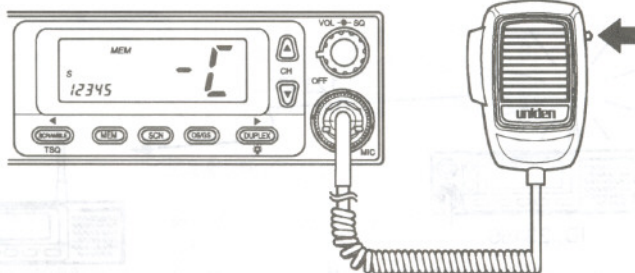

The LCD Frequency display changes to show the last ID transmitted.



Using the channel ▲ or ▼, select the desired memory location.

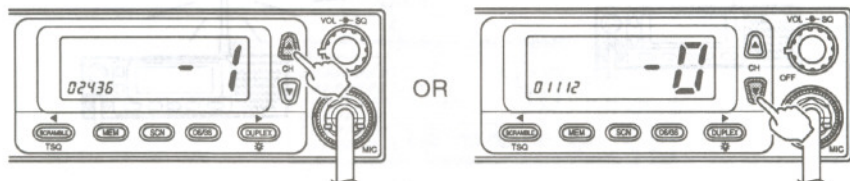

Once located, simply press and hold the **TONE CALL** button to send.

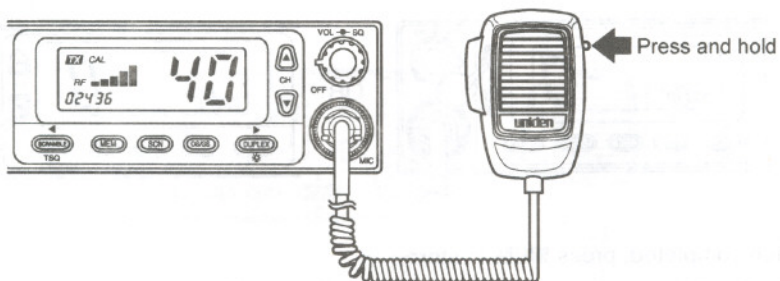

The ID that is sent becomes the Last ID Transmitted. Every time the **TONE CALL** button is pressed this ID will be shown. To send the ID again, simply press and hold the **TONE CALL** button.

## Receiving a Call

When a Call is received from another UH-100 or Compatible radio,

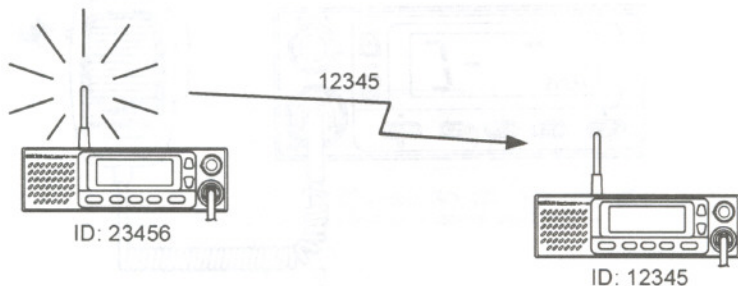

the UH-100 will automatically transmit an acknowledgment tone.

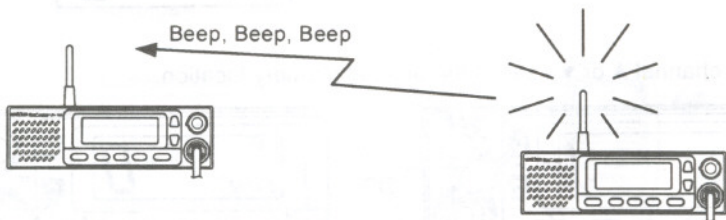

An audible alarm is emitted and the Call icon and the Caller's ID will appear on the display.

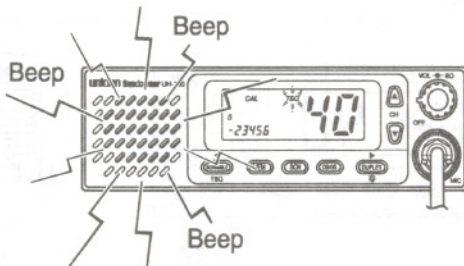

Answer the call in a normal manner.



**Note:** If the radio is left unattended, the Caller ID and the CAL icon will stay on the display. The Call alarm can be configured to continuously beep when unanswered. (Please refer to Selcall Advance Programming on page 32)

## Replying using SELCALL

When a call is received from another UH-100, or compatible radio, the UH-100 automatically decodes and displays the caller ID.

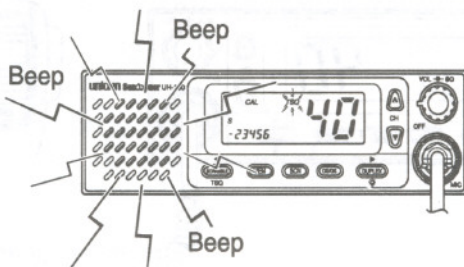

If the radio was left unattended you can call back later by simply pressing and holding the **TONE CALL** button.

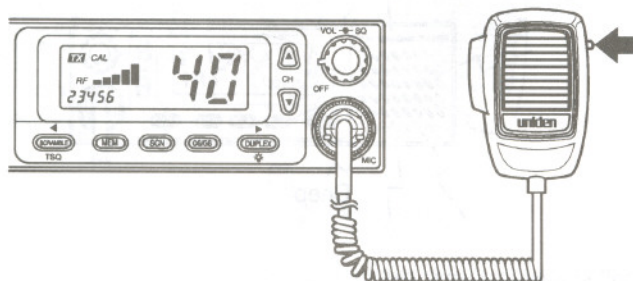

This action automatically loads and transmits the ID on display, and saves you time on programming.

If the received call does not have the Caller ID information, a dash (-) line will be shown in lieu of the Caller ID.

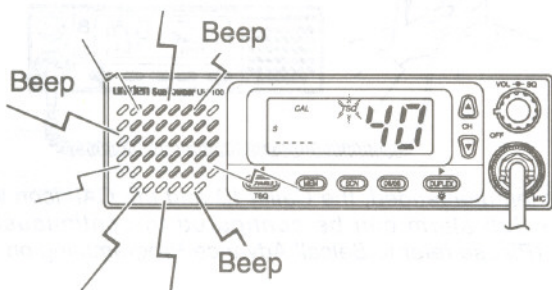

Returning a call in this case will cause the radio to emit an error tone and a "no id" message will be displayed.

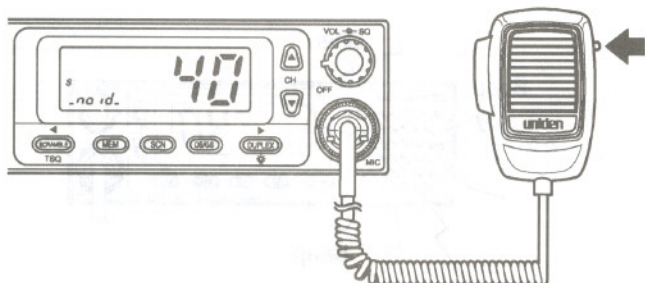

## Group Calling

Most Selcall users will have several members in their group. It is possible that everyone in the group needs to be alerted at the same time, for example when an emergency situation occurs. Calling them one by one can be inconvenient and time consuming. It is possible to create a special code that will be recognized by every radio in the group when transmitted. Your UH-100 incorporates this feature known as Group Calling.

The UH-100 has the capability of being owner programmed to Group Call within groups of 2 to 10, 11 to 100, 101 to 1000 or 1001 to 10000 radios.

While you were setting Selcall ID numbers to be sent, you may have noticed the letter "A" appeared on the LCD from time to time. This letter has a special application. When added in your code to be transmitted, it tells the UH-100 that the call is a Group Call in nature. Note that you have to follow a special format to make a Group Call.

To make a Group Call work all members of the group must have Selcall ID's in a numerical sequence. e.g. group of 10 users may have the following Selcall ID's:

23450	23455
23451	23456
23452	23457
23453	23458
23454	23459

To be able to Group Call all the other 9 radios in your group of 10 you would need to transmit the code 2345A.



ALL radios with 2345 as the first 4 numbers of their ID Code will be alerted.

Using the first four digits followed by "A" is suitable for calling groups of 2 to 10 radios as shown above.

The first 3 digits followed by "AA" is for 11 to 100 radios. (eg 234AA)

The first 2 digits followed by "AAA" is for 101 to 1000 radios. (eg 23AAA)

The first digit followed by "A" is for 101 to 10000 radios. (eg 2AAAA)

You can still call any of the individual members of your group, without calling all the others, by programming the individual's Selcall ID into a separate memory location. e.g. You have your group call code (2345A) in memory location 5. You want to be able to call unit 23453 outside the group so you store 23453 in memory location 3.

The UH-100 differentiates group calls and individual calls by emitting different alarm beeps.

For Group Calls the alarm beep will be a low tone and for individual tone calls the beep will be a high tone.

**Note:** When you transmit a Group Call you will not receive acknowledgment tones from the other radios as you normally do with individual tone calls.

## Tone squelch (Receiver Quieting)

Receiver Quieting, or Tone Squelch (TSQ), is actually SELCALL in action. The UH-100 receiver is muted and you cannot hear any signals until the mute is disengaged by reception of your Selcall code.

Refer to page 8 for explanation of how the squelch system works.

The Squelch discussed previously "screens" the received signal level, however in tone squelch mode, the squelch monitors the signal for your ID.

1. The Tone Squelch Control acts as an electronic lock. Activating the Tone squelch closes this lock.

Regardless of how strong the received signal is, if it does not have the required "electronic key" the gate will remain closed.

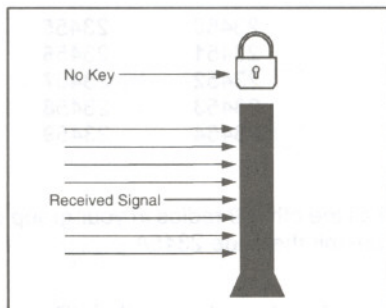

2. If the received signal contains the required key (which is your Radio ID), this electronic lock will open.

The muting circuit is then deactivated on your radio and advises you that a call has been received.

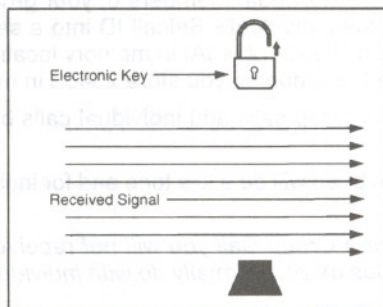

## Activating the Tone Squelch (Receiver Quieting)

1. Select the channel you want to put into quiet mode using the channel selector switches.

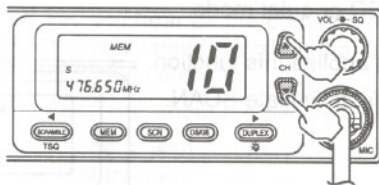

2. Press the **SCRAMBLE/TSQ** button for about 1.5 seconds. One beep is heard and the **TSQ** indicator appears on the display. This channel is now programmed to operate in Quiet Mode.

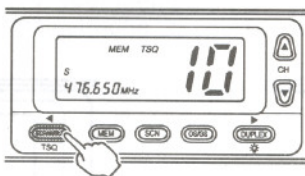

When a quiet mode channel is selected the **TSQ** indicator appears on the display. The microphone PTT is disabled on that channel until a signal with your Selcall ID is received. All other channels can be used as normal.

3. To deactivate any channel in quiet mode first select the relevant channel. Press the **SCRAMBLE/TSQ** button for about 1.5 seconds. Two beeps are heard and the **TSQ** indicator disappears from the display.

## Receiving Calls when in Quiet Mode

The UH-100 will respond in the same way in quiet mode as when it is called while in normal mode.

When the call is left unanswered, however, the radio automatically resumes the quiet condition. (The auto - quiet mode function can be switched ON or OFF, please refer to the Selcall Advance Programming section on page 32)

## Tone Squelch Scanning

You may wish to limit your scanning activities so the UH-100 will only scan the channels you have pre-arranged to use with your SELCALL family. These are the channels you have programmed as TSQ or quiet mode.

Tone Squelch Scanning applies this function.

To activate this feature firstly initiate SCAN.

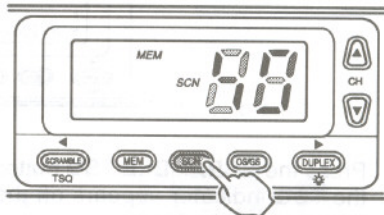

Then press **SCRAMBLE/TSQ**.

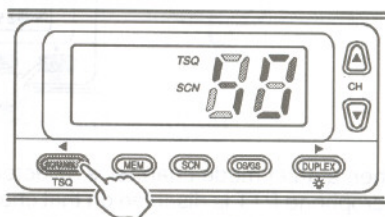

When a call is received the unit will pause scanning and an audible alarm is emitted.

If left unanswered the radio will resume Tone Squelch scanning. The UH-100 can be programmed to deactivate scan automatically when a selective call is received. Please refer to the Selcall Advance Programming Section.

To deactivate Tone Squelch Scanning, simply press **SCN** key.



## SELCALL Advance Programming

The Sundowner UH-100 radio is fully user programmable. It gives you the freedom to select your own radio ID, configure the radio's response when a call is received, change SELCALL parameters for compatibility with other UHF Radio brands, plus much more.

Please read the following procedure carefully to understand the full SELCALL capability of this radio. This will enable you to utilize the SELCALL to maximum effect.

Since the following items are NOT frequently changed, and are characterized as highly significant, a special accessing procedure has been developed to prevent accidental changes or programming.

To access the SELCALL Parameter Programming mode.

First, switch **OFF** the radio.

Press and hold the **OS/GS** key and switch the radio **ON** simultaneously.

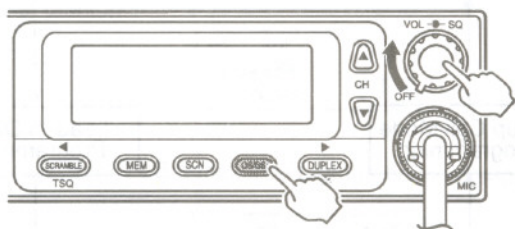

The radio will switch **ON** in the programming Mode.

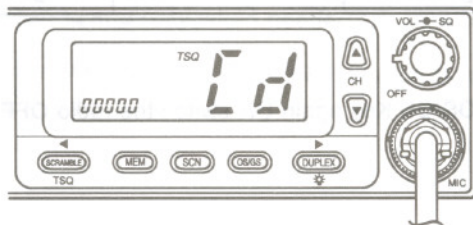

The illustration below outlines the user programmable parameter menu.

Once inside the programming mode, use the ▲ or ▼ to scroll on the menu.

Press **MEM** to select. Change the setting using the ▲ or ▼ key. Press **MEM** again to store and exit.

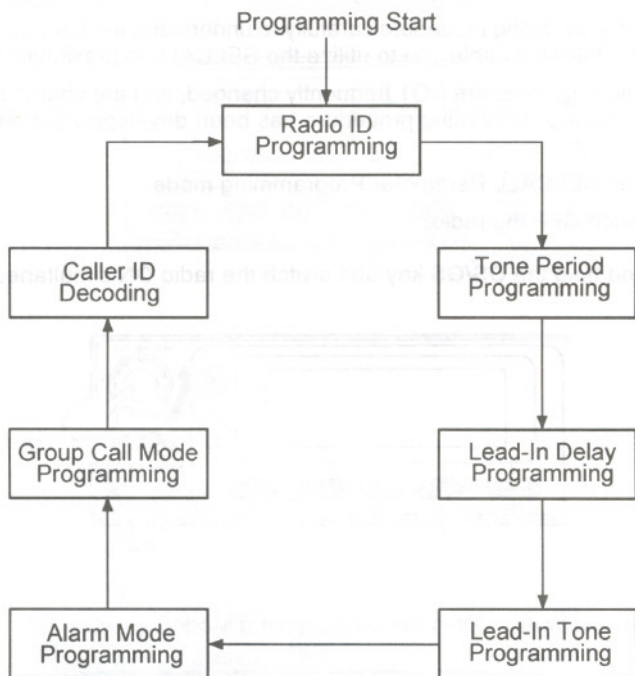

Press and Hold the **OS/GS** Key again OR switch the radio **OFF** then **ON** to exit this mode.

## Radio ID Programming

To program your own Radio ID, perform the following procedure.

From the main menu, using the ▲ or ▼ key, go to the Radio ID Programming Menu. (If you have never changed this parameter, the Radio ID 00000 will be displayed)

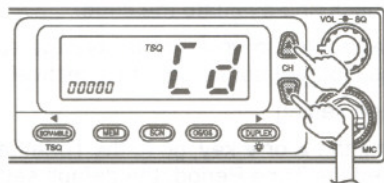

Press the **MEM** key to start programming. The last digit of the Radio ID will flash. This indicates that you can now enter your new Radio ID.

The flashing digit is the one you can change. To select another digit, use the ◀ or ▶ to move position.



To change the flashing digit value, use the ▲ or ▼ key.

When completed, press the **MEM** and the new Radio ID will be stored into the memory.

## Tone Period Programming

Tone Period is the duration of one tone in a SELCALL ID sequence. The setting of this parameter depends on the application. On long distance communications, where the signal strength of the transmitted information is greatly reduced and affected by noise, it is advisable to use a longer tone period. A long tone period gives the decoder more time and information to check and evaluate the code.

**Important Note:** Ensure all radios in your group use the same tone period setting, otherwise, you will not be able to selectively call one another.

To change the Tone Period setting.

From the main menu, using the ▲ or ▼ key, go to the Tone Period Programming Menu. (If you have never changed the Tone Period, the default setting is 40 mSec)

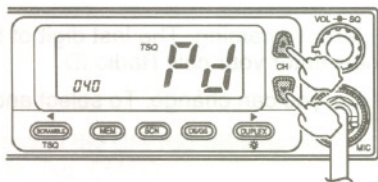

Press the **MEM** key to start programming. The Tone Period on display will flash. This indicates that you can now change the setting.

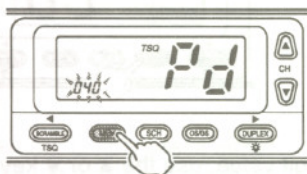

To change, use the ▲ or ▼ key.

You can select either, 40, 70, 100 or 20 mSec.

When completed, press the **MEM** to store the new Tone Period setting into the memory.

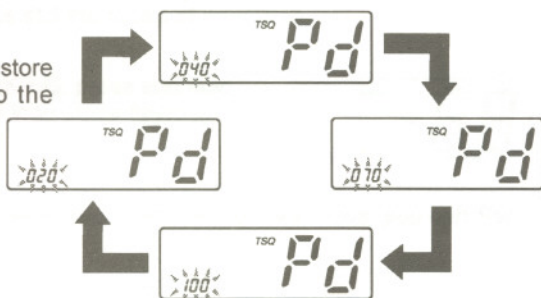

## Lead - In Delay Programming

Lead-in Delay is a SELCALL transmission parameter that "wakes-up" and helps the receiver of the other radio to lock onto the incoming signal. Each time a SELCALL ID is transmitted, the Lead-in Delay attaches itself to the beginning of the code sequence and causes the transmitter to be on for a longer period prior to the code transmission. This makes for a stronger communication link between the transmitter and the other receiver.

The major advantage of having the Lead-in Delay longer is when selectively calling another radio via a repeater station. A long Lead-in Delay helps to stabilize both the communication link from your radio to the repeater station and from the repeater station to the other radio.

To change the Lead - In Delay setting.

From the main menu, using the ▲ or ▼ key, go to the Lead - in Delay Programming Menu. (If you have never changed the Lead - In delay duration, the default setting is 500 mSec)

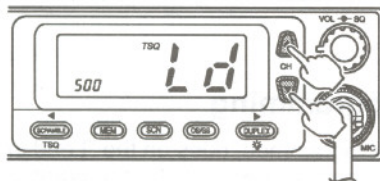

Press the **MEM** key to start programming. The Lead In Delay on display will flash. This indicates that you can now change the setting.

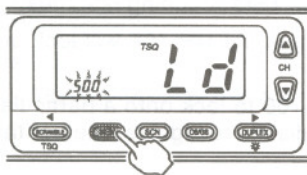

To change, use the ▲ or ▼ key. You can select either 500, 1000, 2000, 3000 or 4000 mSec.

When completed, press the **MEM** key. The new Lead - In Delay stops flashing and is stored in the radio memory.

To return to normal operation, press and hold the **OS/GS** key for about 1.5 seconds, or, press either the ▲ or ▼ key to go to the next programmable parameter.

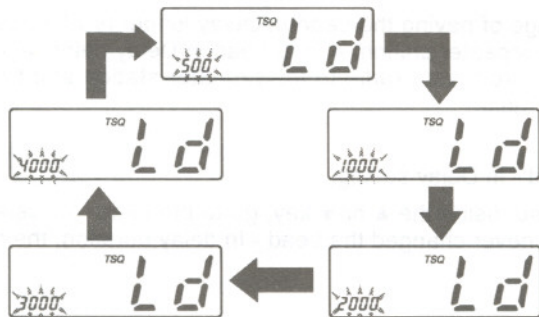

## Lead - In Tone Programming

The Lead-In Tone when programmed, rides on the "Lead in Delay". When transmitting a Selcall ID a continuous tone will be heard for the duration of the Lead In Delay.

The main function of the Lead - In Tone is to increase the probability of contact between radios when Tone Squelch Scanning.

Unlike normal scanning, TSQ Scanning monitors the detected carrier for the presence of Lead - In tone. Without it, TSQ scanning resumes.

If a Lead - In Tone is present the UH-100 will lock onto that signal and wait for the SELCALL ID.

You can program the UH-100 to lock onto a particular Lead - In Tone. This feature enables the radio to immediately recognize whether the signal present is intended for your group.

i.e. If you are using Tone 1, your radio during TSQ scanning will lock only onto signal with Tone 1 as its Lead - In tone.

**Note:** Should you wish your radio to lock onto any transmission regardless of Lead-In tone type present select "Tone \_\_".

To change the Lead-In Tone setting.

From the main menu, using the ▲ or ▼ key, go to the Lead-In Tone Programming Menu. (If you have never changed the Lead-In delay duration the default setting is Tone 1)

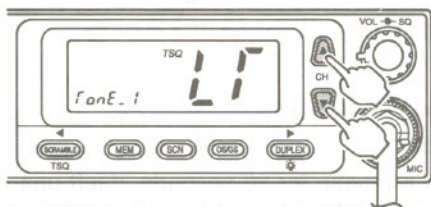

Press the **MEM** key to start programming.

The Lead In Tone on display will flash. This indicates that you can now change the setting.



To change, use the ▲ or ▼ key. You can select any Tones 1 to 9, A to F or "\_ \_".

When completed, press the **MEM** key. The new Lead-In Tone stops flashing and will be stored in the radio memory.

To return to normal operation, press and hold the **OS/GS** key for about 1.5 seconds, or press either the ▲ or ▼ key to go to the next programmable parameter.

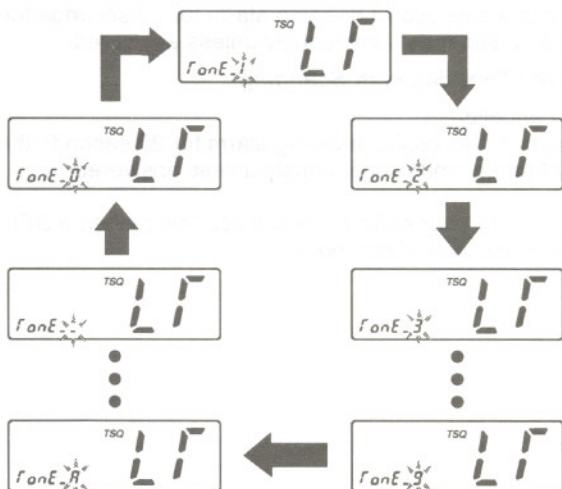

## Alarm Mode Programming

The UH-100 has two types of alarm set-up.

### Set-up 1: Auto-Resume (Default setting)

When a Call is received in,

i) **Normal Mode**

The alarm will sound only for 10 seconds

ii) **Tone Squelch Mode**

The quieting circuit will open for 20 seconds. If left unanswered Tone Squelch condition resumes. The alarm will sound for 10 seconds only.

iii) **Normal Mode / Tone Squelch Scanning**

The alarm will sound only for 10 seconds.

If left unanswered, scanning RESUMES after 20 seconds. The **CAL** icon will be continuously lit on the display indicating that a call has been received. To look for the called channel, cancel SCAN and use the ▲ or ▼ key. The called channel will display a **CAL** when found.

### Set-up 2: Continuous Alarm

When a call is received in,

i) **Normal Mode**

The radio emits a successive beeping alarm for 20 seconds then two successive beeps every four seconds continuously unless answered.

ii) **Tone Squelch Mode**

The Tone Squelch condition is cancelled.

The radio emits a successive beeping alarm for 20 seconds then two successive beeps every four seconds continuously unless answered.

iii) **Normal Mode / Tone Squelch Scanning**

Scanning is cancelled.

The radio emits a successive beeping alarm for 20 seconds then two successive beeps every four seconds continuously unless answered.

**Note:** Should you wish your radio to cancel scanning when a SELCALL is received, select the continuous alarm mode.



To change the Alarm Mode setting.

From the main menu, using the ▲ or ▼ key, go to the Alarm Mode Programming Menu. (If you have never changed the Alarm setting, the default setting is Auto)

Press the **MEM** key to start programming. The Alarm setting on display will flash. This indicates that you can now change the setting.

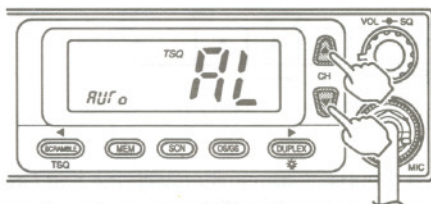

To change, use the ▲ or ▼ key.

When completed, press the **MEM** key. The new Alarm setting stops flashing and will be stored in the radio memory.

To return to normal operation, press and hold the **OS/GS** key for about 1.5 seconds, or press either the ▲ or ▼ key to go to the next programmable parameter.

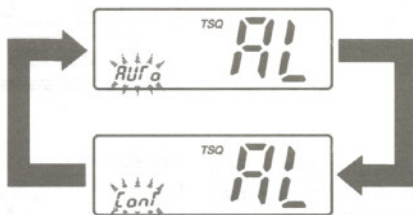

## Group Call Mode Programming

There are two ways the Group Call Code is transmitted.

The Uniden UH-100 can be programmed to accept either format.

**Group 1** setting recognizes a group call transmitted with equal tone period. i.e. Calling 100 radios, with a tone period setting of 40 mSec.



**Group 2** setting recognizes a group call transmitted with the first Group Call Tone period extended by 3 times the original tone period setting (this is also the default setting).



To change the Group Call setting.

From the main menu, using the ▲ or ▼ key, go to the Group Call Mode Programming Menu. (If you have never changed the Group Call setting before, its default is Group 2)

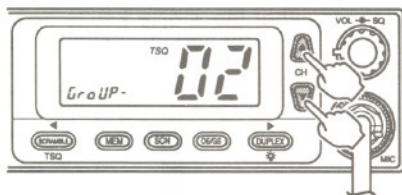

Press the **MEM** key to start programming. The Alarm setting on display will flash. This indicates that you can now change the setting.



To change, use the ▲ or ▼ key.

When completed, press the **MEM** key. The new Group Call setting stops flashing and will be stored in the radio memory.

To return to normal operation, press and hold the **OS/GS** key for about 1.5 seconds, or press either the ▲ or ▼ key to go to the next programmable parameter.

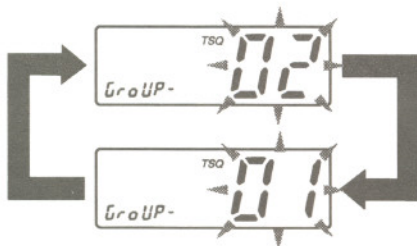

## Caller ID Decoding

The Sundowner UH-100 radio uses a total of 10 digits when making a Selective Call. The first five digit is the ID of the radio to be called and the last five digit is its own ID.

Some radios in the market use only nine digit. If any member of your group is not using Uniden radio, a quick check of its operating guide will advise you the signalling format it is using.

To change the Caller ID setting.

From the main menu, using the ▲ or ▼ key, go to the Caller ID Decoding Menu. (If you have never changed the Caller ID decoding set-up, the default is digit 10)

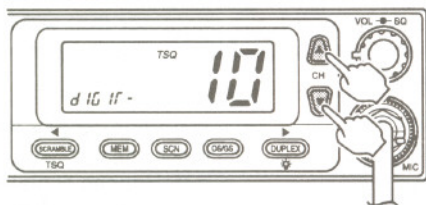

Press the **MEM** key to start programming. The digit Indicator on display will flash. This indicates that you can now change the setting.

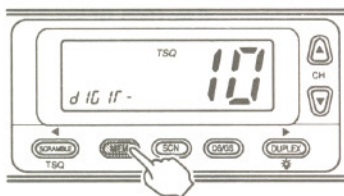

To change, use the ▲ or ▼ key.

When completed, press the **MEM** key. The new Caller ID setting stops flashing and will be stored in the radio memory.

To return to normal operation, press and hold the **OS/GS** key for about 1.5 seconds, or press either the ▲ or ▼ key to go to the other programmable parameter.

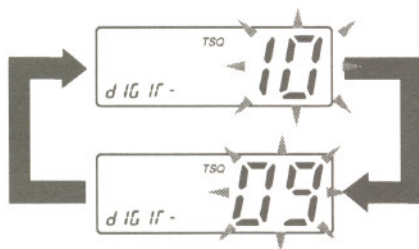

---

---

## Service

---

---

Should you find it desirable or necessary to service your UH-100, we suggest you contact the Uniden Dealer where your purchase was made. Your dealer will be able to assist you with complete service information.

If you require service that is within the terms of your warranty you should present a copy of your receipt to your dealer to authenticate your claim.

If you find it inconvenient to obtain service assistance from a dealer, please pack your radio in a suitable container that will provide adequate protection. Enclose a note describing the problem and a copy of your receipt, and send the radio transportation prepaid to:

Uniden Australia Pty Limited  
Customer Service Division  
345 Princes Highway  
Rockdale NSW 2216

Ph. (02) 9599-3100

Fax (02) 9599-3278

---

---

## Care and Maintenance

---

---

### Notice

If the UH-100 has been subjected to extreme high temperature (above 60°C) for a prolonged period of time, blackening of the Liquid Crystal Display (LCD) may occur. This is not a fault. Normal LCD operation resumes when the temperature stabilizes back to standard operating conditions (0 to 55°C).

### Preventive Maintenance

The following system checks should be made every six to twelve months:

1. Check the Standing Wave Ratio (SWR).
2. Inspect the tightness of all electrical connections.
3. Inspect the antenna coaxial cable for wear or breaks on the shielding.
4. Inspect the tightness of all screws and other mounting hardware.

### Troubleshooting

Should the unit malfunction or perform poorly, follow the procedures indicated below:

1. If the transceiver is completely inoperative...
  - \* Check the power cord and fuse.
2. If there is trouble with receiving...
  - \* Check the VOLUME control setting.
  - \* Be sure the SQUELCH is adjusted properly. Possibly the radio is over-squelched.
  - \* Check that the radio is in an operational mode.
3. If there is trouble with transmitting...
  - \* Check that the transmission line (coaxial cable) is securely connected to the **ANTENNA** connector.
  - \* Check that the antenna is fully extended for proper operation.
  - \* Check that all transmission line (coaxial cable) connections are secure and free of corrosion.

### Memory Backup

A built-in capacitor protects the channels stored in the SUNDOWNER UH-100 memory for up to 2 weeks after the DC power cable is disconnected.

---

---

## UHF CB Channel Information

---

---

This radio has been designed to provide a high level of performance in the Citizens Band Radio Service, which is comprised of the following frequency assignments:

### SIMPLEX Operating Mode

Channel	Channel Frequency in MHz
1	476.425
2	476.450
3	476.475
4	476.500
5	476.525
6	476.550
7	476.575
8	476.600
9	476.625
10	476.650
11	476.675
12	476.700
13	476.725
14	476.750
15	476.775
16	476.800
17	476.825
18	476.850
19	476.875
20	476.900
21	476.925
22	476.950
23	476.975
24	477.000
25	477.025
26	477.050
27	477.075
28	477.100
29	477.125
30	477.150
31	477.175
32	477.200
33	477.225
34	477.250
35	477.275
36	477.300
37	477.325
38	477.350
39	477.375
40	477.400

## DUPLEX Operating Mode

<b>Channel Assignment</b>	<b>Receive Frequency (MHz)</b>	<b>Transmit Frequency (MHz)</b>
CH1	476.425	477.175 (CH31)
CH2	476.450	477.200 (CH32)
CH3	476.475	477.225 (CH33)
CH4	476.500	477.250 (CH34)
CH5	476.525	477.275 (CH35)
CH6	476.550	477.300 (CH36)
CH7	476.575	477.325 (CH37)
CH8	476.600	477.350 (CH38)

---

---

# Specifications

---

---

## General

Channels	: 40
Frequency Range	: 476.425MHz to 477.40MHz
Crystal Oscillator	: 4
Microphone	: 600 ohm, Dynamic Type
Speaker	: 8 ohm, 3.5W
Antenna Connector	: M-Type
Jacks & Connectors	: Mic 4P Metal EXT SP 3.5φ DC Power 2P Type
Controls	: PRESS-TO-TALK Button (Microphone) TONE CALL Button (Microphone) SCAN/SEEK Button OS/GS Button SCRAMBLE Button BACK LIGHT CONTROL Button OFF/VOLUME Control SQUELCH Control MEMORY Button DUPLEX Button TONE SQUELCH Button CHANNEL UP/DOWN Button
Indicators	: DUPLEX Indicator TX Indicator CALL indicator TSQ Indicator GROUP SCAN Indicator MEMORY Indicator CHANNEL Indicator PRI Indicator S/RF Level Indicator SCAN Indicator TX/RX FREQUENCY, 5 digits SELCALL ID Indicator SCRAMBLE Indicator
Cabinet Size	: W : 172 mm H : 52 mm D : 145 mm
Weight	: 1.0 kg
Operating Temperature	: 0° to +55°C
Power Requirements	: 13.8 VDC Nominal
SMA Approval	: Type accepted under SMAS250
Accessories	: DC power cable with built-in-fuse, microphone, microphone hanger, mounting bracket screw (2), washer (2) for microphone hanger, microphone hanger screw (2), washer star (2) for mounting bracket, rubber washer (2) for mounting bracket, knob (2) for mounting bracket



## Measurement Conditions

Power Source	: 13.8V (DC)
Antenna Impedance	: 50 ohm
Test Temperature	: 25°C
Modulation Frequency	: 1 kHz (RX/TX)
Mean Signal Input Level	: 1000 $\mu$ V
Reference Audio Output Power	: 500mW
Reference Modulation Deviation	: $\pm$ 3 kHz deviation
Audio Output Load	: 8 ohms resistive

## Transmitter Section

Frequency Tolerance at 25°C (5 minutes after turning on)	: $\pm$ 0.5 kHz
Carrier Power	: 5W (max)
Spurious Emission	: -40 dBm
Current Drain	: 1500mA
Modulation Frequency Response (1 kHz, 0 dB reference, at 1 kHz deviation)	
Lower at 500 Hz	: -6 dB
Upper at 2.0 kHz	: +5 dB
Microphone Sensitivity for 3 kHz Deviation	: 1.5mV
Maximum Deviation	
at 1 kHz	: $\pm$ 4.5 kHz
at 6 kHz	: $\pm$ 1.5 kHz (max)

## Receiver Section

Sensitivity at 12dB SINAD	: 0.23 $\mu$ V or better
Overall Audio Fidelity (1 kHz, 0 dB reference)	:
Lower at 500 Hz	: +4 dB
Upper at 2 kHz	: -6 dB
Adjacent Channel Selectivity ( $\pm$ 25 kHz)	: 70 dB
Maximum Audio Output Power	: 3W
Audio Output Power at 10% THD	: 2W
Hum & Noise Ratio at Input 1mV	: 45 dB
Squelch Sensitivity at Threshold	: 0.1 $\mu$ V
Squelch Sensitivity at Tight	: 1 $\mu$ V
Image Rejection Ratio	: 55 dB
IF Rejection Ratio	: 100 dB
Oscillator Dropout Voltage	: 9V

Current Drain at No Signal	: 350mA
Current Drain at Maximum Output	: 550mA

## SELCALL

Standard	: CCIR International
Encode/Decode Format	: 5 Tones
Transmit Tones	: 0 ~ 9, A ~ D, F
Receive Tones	: 0 ~ 9
Tone Periods	: 20, 40, 70, 100mSec
Lead-In Delay	: 500mSec, 1, 2, 3, 4Sec
Lead-In Tone	: 0 ~ 9, A ~ F

---

---

# Warranty

---

---

## Uniden Sundowner UH-100 UHF CB Radio Australian One Year Warranty

**Note:** Please keep your sales docket as it provides evidence of warranty.

**WARRANTOR:** UNIDEN Australia Pty. Limited ACN 001 865 498

**ELEMENTS OF WARRANTY:** UNIDEN warrants to the original retail owner for the duration of this warranty, its Sundowner UH-100 UHF CB Transceiver Radio (hereinafter referred to as the Product) to be free from defects in materials and craftsmanship with only the limitations or exclusions set out below.

**WARRANTY DURATION:** This warranty to the original retail owner only, shall terminate and be of no further effect ONE(1) Year after the date of original retail sale. This warranty will be deemed invalid if the product is; (A) Damaged or not maintained as reasonable and necessary, (B) Modified, altered or used as part of any conversion kits, subassemblies, or any configurations not sold by Uniden, (C) Improperly installed, (D) Repaired by someone other than an authorized Uniden Repair Agent for a defect or malfunction covered by this warranty, (E) Used in conjunction with any equipment or parts or as part of a system not manufactured by Uniden, (F) Installed, programmed or serviced by anyone other than an authorized Uniden Repair Agent, or (G) Where the Serial Number label of the product has been removed or damaged beyond recognition.

**PARTS COVERED:** This warranty covers for 1 year, the Sundowner UH-100 UHF CB Transceiver Unit only. All accessories, mounting bracket, DC cable, fuse, and microphone are covered for 90 days.

**STATEMENT OF REMEDY:** In the event that the product does not conform to this warranty at any time while this warranty is in effect, the warrantor at its discretion, will repair the defect or replace the product and return it to you without charge for parts and service. THIS WARRANTY DOES NOT COVER OR PROVIDE FOR THE REIMBURSEMENT OR PAYMENT OF INCIDENTAL OR CONSEQUENTIAL DAMAGES.

**WARRANTY CARD:** If a warranty card has been included with this product, please fill it in and return it to us within 14 days of purchase. Your name and serial number of the product will then be registered in our database and this will help us process your claim with greater speed and efficiency should you require warranty service.

**PROCEDURE FOR OBTAINING PERFORMANCE OR WARRANTY:** In the event that the Product does not conform to this warranty, the Product should be shipped or delivered, freight prepaid, with evidence of original purchase, (eg/ a copy of the sales docket, to the warrantor at:

**UNIDEN AUSTRALIA PTY, LIMITED  
SERVICE DIVISION**

345 Princes Highway, Rockdale, NSW 2216  
Ph (02) 9599 3100 FAX (02) 9599 3278

Customers in other states should ship or deliver the Product  
freight pre-paid to the nearest Uniden Authorized Repair Centre.  
(Contact Uniden for the Warranty Agent nearest you.)

**uniden®**

**Australia Pty. Ltd.**

345 Princes Highway, Rockdale, N.S.W.2216

Phone:(02) 9599 3100

Fax:(02) 9599 3278

Uniden® is a registered trademark of *Uniden Corporation*.  
Features, specifications, and availability of optional accessories are all  
subject to change without notice.

## Free Manuals Download Website

<http://myh66.com>

<http://usermanuals.us>

<http://www.somanuals.com>

<http://www.4manuals.cc>

<http://www.manual-lib.com>

<http://www.404manual.com>

<http://www.luxmanual.com>

<http://aubethermostatmanual.com>

Golf course search by state

<http://golfingnear.com>

Email search by domain

<http://emailbydomain.com>

Auto manuals search

<http://auto.somanuals.com>

TV manuals search

<http://tv.somanuals.com>