



Xerox DocuPrint 100/115/135/180 EPS

# operator guide

701P24790

April, 2005



Prepared by:  
Xerox Corporation  
Global Knowledge and Language Services  
800 Philips Road Bldg. 845-17S  
Webster, New York 14580  
USA

©2005 by Xerox Corporation. All rights reserved.

Copyright protection claimed includes all forms and matters of copyrightable material and information now allowed by statutory judicial law or hereinafter granted, including without limitation, material generated from the software programs displayed on the screen such as icons, screen displays, or looks.  
Printed in the United States of America.

XEROX® and all Xerox product names mentioned in this publication are trademarks of XEROX CORPORATION.

Other company trademarks are also acknowledged.

Changes are periodically made to this document. Changes, technical inaccuracies, and typographic errors will be corrected in subsequent editions.

# Table of contents

## Safety

Laser safety	v
Ozone information: U. S. only	v
Operation safety: U. S.	v
Operation safety: Europe	vi
Warning markings	vii
Electrical supply	vii
Ventilation	vii
Operator accessible areas	viii
Maintenance	viii
Before cleaning your product	viii
CE mark: Europe only	viii
Radio and telecommunications equipment directive (Europe only)	ix
For further information	x

## Introduction

About this guide	xi
Contents	xi
Conventions	xi
Documentation	xii
DocuPrint 100/115/135/155/180 EPS documentation	xiii

## 1 Overview

Functional overview	1-1
Host connectivity options	1-2
Data formats supported	1-3
Stock specifications	1-3
Stock sizes	1-4
Paper weights	1-4
Special stocks	1-5
General paper characteristics to look for	1-5
Printing process and job flow	1-6
Printer overview	1-8
Printer components	1-10
Processor Feeder Trays	1-10
Sample tray	1-10
Attention light	1-11
Purge tray	1-11
Feeder trays	1-11
Stacker bins	1-12
Feeder/stacker modules	1-14
Printer control console (not shown)	1-15
Printer configurations	1-15
Printer options	1-16
Bypass transport	1-16
Support and interface with feeders	1-17

7 by 10 inch enablement kit .....	1-18
Paper paths .....	1-18
Printer paper path .....	1-18
Bypass transport paper path .....	1-20
Controller overview .....	1-20
Controller components .....	1-21
Sun workstation .....	1-21
External components and options .....	1-26
Controller stand .....	1-26
Online and offline interfaces .....	1-26
Moving the controller .....	1-27
Tape drives overview .....	1-29
Paper sizing and print speed .....	1-30
Long and short edge feeding .....	1-31
Paper width and throughput speed (LCDS printing only) .....	1-31
Paper size and pitch mode minimum and maximum .....	1-33
Feed direction for standard paper sizes .....	1-35

## 2 Managing the printer

Controlling the printer .....	2-1
Interrupting printing .....	2-1
Resuming printing .....	2-1
Powering on the printer .....	2-1
Powering off the printer .....	2-1
Powering off the printer immediately .....	2-2
Adjusting the registration transport roll levers for heavy paper .....	2-2
Loading paper .....	2-3
Unloading a stacker bin .....	2-8

## 3 Managing the system

Starting, stopping, and rebooting the system .....	3-1
Powering on the controller .....	3-1
Powering on the printer .....	3-1
Holding queues .....	3-2
Releasing queues .....	3-2
Rebooting the system (warm boot) .....	3-2
Performing a deferred shutdown and reboot .....	3-3
Performing an immediate shutdown and reboot .....	3-3
Restarting the DocuSP software .....	3-4
Powering off the system .....	3-4
Performing an emergency power off .....	3-5
Powering off the controller .....	3-5
Powering off the printer .....	3-6
Operating the 18/36 track tape drive .....	3-7
Powering on the tape drive .....	3-7
Powering off the tape drive .....	3-8
Placing the tape drive online .....	3-9
Loading a tape .....	3-9
Unloading a tape .....	3-10
Guidelines for handling cartridges .....	3-11
Setting file protection .....	3-12
Printing the online Help documentation .....	3-13

## 4 Maintaining the system

Paper care	4-1
Storing paper	4-1
Conditioning paper	4-3
Paper curl	4-3
Using consumables	4-4
Adding fuser agent	4-4
Replacing the dry ink waste container	4-7
Replacing the dry ink cartridge	4-11
Using the custom transfer assist blade	4-13
Cleaning the system and its components	4-14
Cleaning the 18/36-track cartridge tape drive	4-15
Cleaning the 26-track cartridge tape drive	4-15
Cleaning the DVD drive	4-16
Cleaning the diskette drive	4-16
Cleaning the sensors and the reflecting surfaces	4-16
Cleaning the Q850 sensor	4-16
Cleaning the Q1011 sensor and mirror	4-18
Cleaning additional sensors	4-19
Cleaning the display	4-22
Cleaning the exterior surfaces of the system	4-22

## 5 Troubleshooting

Undeclared faults	5-1
Problem classifications	5-1
Troubleshooting client problems	5-2
Solving FreeFlow Prepress problems	5-2
Troubleshooting Graphical User Interface (GUI) problems	5-2
Troubleshooting print quality problems	5-3
Resolving print quality problems on a PostScript job	5-3
Isolating and resolving printer-driven print quality problems	5-4
Resolving font problems	5-4
Troubleshooting job flow problems	5-5
Troubleshooting job integrity problems	5-5
Troubleshooting PDL problems	5-6
Isolating HP PCL file problems	5-6
Isolating PostScript file problems	5-6
Isolating TIFF file problems	5-7
Isolating PDF file problems	5-8
Troubleshooting process problems	5-8
Troubleshooting productivity and performance problems	5-9
Troubleshooting problems with saving jobs	5-10
Crash recovery	5-10
Streaming mode	5-10
UI recovery messages	5-11
Recovery message examples	5-11
Spooling mode	5-12
Points to note	5-12
Clearing online print data	5-13
Online gateway faults/submitting a job from the host	5-13
Obtaining information about a job	5-14
Data type on the Online Manager window	5-15
Streaming queue release setup	5-15
Incorrect printer state on host	5-15

Clearing paper jams .....	5-15
Aids to paper jam clearance .....	5-16
Clearing paper jams in all printer areas .....	5-16
Checking job integrity following a paper jam .....	5-17
Clearing paper jams in printer areas 2 through 20 .....	5-18
Clearing a paper jam in the bypass transport .....	5-29
Clearing a misfeed (feeder tray fault) .....	5-31
Troubleshooting frequent misfeeds (processor feeder trays) .....	5-33
Incorrect paper size message .....	5-36
Generating a test page .....	5-36
Troubleshooting stacker problems .....	5-37
Troubleshooting paper curl problems .....	5-37
Checking paper curl .....	5-37
Adjusting the decurler lever .....	5-40
Troubleshooting the 36-track tape drive .....	5-41
Performing basic recovery .....	5-41
Troubleshooting initial program load (IPL) failure .....	5-41
Solving other cartridge tape drive problems .....	5-42
Calling for service .....	5-45

## 6 Supplies

Available supplies .....	A-1
How to order supplies .....	A-5

## Index

# Safety

## Laser safety

---



**WARNING:** *Adjustments, use of controls, or performance of procedures other than those specified herein may result in hazardous light exposure.*

The Xerox DocuPrint printers are certified to comply with the performance standards of the U.S. Department of Health, Education, and Welfare for Class 1 laser products. Class 1 laser products do not emit hazardous radiation. The DocuPrint printers do not emit hazardous radiation because the laser beam is completely enclosed during all modes of customer operation.

The laser danger labels on the system are for Xerox service representatives and are on or near panels or shields that must be removed with a tool.

**DO NOT REMOVE LABELED PANELS OR PANELS NEAR LABELS. ONLY XEROX SERVICE REPRESENTATIVES HAVE ACCESS TO THESE PANELS.**



## Ozone information: U. S. only

---

This product produces ozone during normal operation. The amount of ozone produced depends on copy volume. Ozone is heavier than air. The environmental parameters specified in the Xerox installation instructions ensure that concentration levels are within safe limits. If you need additional information concerning ozone, call 1-800-828-6571 to request the Xerox publication 600P83222, *OZONE*.

## Operation safety: U. S.

---

Your Xerox equipment and supplies have been designed and tested to meet strict safety requirements. They have been

approved by safety agencies, and they comply with environmental standards. Please observe the following precautions to ensure your continued safety.



**WARNING:** *Improper connection of the equipment grounding conductor may result in risk of electrical shock.*

- Always connect equipment to a properly grounded electrical outlet. If in doubt, have the outlet checked by a qualified electrician.
- Never use a ground adapter plug to connect equipment to an electrical outlet that lacks a ground connection terminal.
- Always place equipment on a solid support surface with adequate strength for its weight.
- Always use materials and supplies specifically designed for your Xerox equipment. Use of unsuitable materials may result in poor performance and may create a hazardous situation.
- Never move either the printer or the controller without first contacting Xerox for approval.
- Never attempt any maintenance that is not specifically described in this documentation.
- Never remove any covers or guards that are fastened with screws. There are no operator-serviceable areas within these covers.
- Never override electrical or mechanical interlocks.
- Never use supplies or cleaning materials for other than their intended purposes. Keep all materials out of the reach of children.
- Never operate the equipment if you notice unusual noises or odors. Disconnect the power cord from the electrical outlet and call service to correct the problem.

If you need any additional safety information concerning the equipment or materials Xerox supplies, call Xerox Product Safety at the following toll-free number in the United States:

**1-800-828-6571**

For customers outside the United States, contact your local Xerox representative or operating company.

## Operation safety: Europe

---

This Xerox product and supplies are manufactured, tested and certified to strict safety regulations, electromagnetic regulations and established environmental standards.

Any unauthorised alteration, which may include the addition of new functions or connection of external devices, may impact the product certification.



---

Please contact your Xerox representative for more information.

## Warning markings

---

All warning instructions marked on or supplied with the product should be followed.



This WARNING alerts users to areas of the product where there is the possibility of personal damage.



This WARNING alerts users to areas of the product where there are heated surfaces, which should not be touched.

## Electrical supply

---

This product shall be operated from the type of electrical supply indicated on the product's data plate label. If you are not sure that your electrical supply meets the requirements, please consult your local power company for advice.



This product must be connected to a protective earth circuit. This product is supplied with a plug that has a protective earth pin. This plug will fit only into an earthed electrical outlet. This is a safety feature. Always connect equipment to a properly grounded electrical outlet. If in doubt, have the outlet checked by a qualified electrician.

To disconnect all electrical power to the product, the disconnect device is the power cord. Remove the plug from the electrical outlet.

## Ventilation

---

Slots and opening in the enclosure of the product are provided for ventilation. Do not block or cover the ventilation vents, as this could result in the product overheating.

This product should not be placed in a built-in installation unless proper ventilation is provided, please contact your Xerox representative for advice.

Never push objects of any kind into the ventilation vents of the product.

## Operator accessible areas

---

This product has been designed to restrict operator access to safe areas only. Operator access to hazardous areas is restricted with covers or guards, which would require a tool to remove. Never remove these covers or guards.

## Maintenance

---

Any operator product maintenance procedures will be described in the user documentation supplied with the product. Do not carry out any maintenance on the product, which is not described in the customer documentation.

## Before cleaning your product

---

Before cleaning this product, unplug the product from the electrical outlet. Always use materials specifically designated for this product, the use of other materials may result in poor performance and may create a hazardous situation. Do not use aerosol cleaners, they may be flammable under certain circumstances.

## CE mark: Europe only

---



January 1, 1995: Council Directive 73/23/EEC, amended by Council Directive 93/68/EEC, approximation of the laws of the member states related to low voltage equipment.

January 1, 1996: Council Directive 89/336/EEC, approximation of the laws of the member states related to electromagnetic compatibility.

March 9, 1999: Council Directive 99/5/EC, on radio equipment and telecommunications terminal equipment and the mutual recognition of their conformity.

A full declaration of conformity, defining the relevant directives and referenced standards, can be obtained from your Xerox representative.

In order to allow this equipment to operate in proximity to Industrial, Scientific and Medical (ISM) equipment, the external

radiation for the ISM equipment may have to be limited or special mitigation measures taken.

This is a Class A product. In a domestic environment this product may cause radio frequency interference, in which case the user may be required to take adequate measures.

Shielded interface cables must be used with this product to maintain compliance with Council Directive 89/36/EEC.

## Radio and telecommunications equipment directive (Europe only)

---

### Certification to 1999/5/EC Radio Equipment and Telecommunications Terminal Equipment Directive:

This Xerox product has been self-certified by Xerox for pan-European single terminal connection to the analog public switched telephone network (PSTN) in accordance with Directive 1999/5/EC.

The product has been designed to work with the national PSTNs and compatible PBXs of the following countries:

- Austria
- Belgium
- Denmark
- Finland
- France
- Germany
- Greece
- Iceland
- Ireland
- Italy
- Luxembourg
- Netherlands
- Norway
- Portugal
- Spain
- Sweden
- Switzerland
- United Kingdom

In the event of problems, contact your local Xerox representative in the first instance.

This product has been tested to, and is compliant with, TBR21, a specification for terminal equipment for use on analog switched telephone networks in the European Economic area.

The product may be configured to be compatible with other country networks. Please contact your Xerox representative if your product needs to be reconnected to a network in another country. This product has no user-adjustable settings.



**NOTE:** *Although this product can use either loop disconnect (pulse) or DTMF (tone) signaling, it should be set to use DTMF signaling. DTMF signaling provides reliable and faster call setup.*

Modification or connection to external control software, or to external control apparatus not authorized by Xerox, invalidates its certification.

## **For further information**

---

---

For more information on Environment, Health and Safety in relation to this Xerox product and supplies, please contact the following customer help lines:

Europe: +44 1707 353434

USA: 1 800 8286571

Canada: 1 800 8286571

# Introduction

This document provides information on how to perform operator tasks for the DocuPrint 100/115/135/155/180 Enterprise Printing System (EPS).

## About this guide

---

Before using this documentation, become familiar with its contents and conventions.

## Contents

---

This guide contains the following:

- Chapter 1, “Overview,” provides a functional overview of the system; describes the controller and printer components; and explains the printing process, and the job flow.
- Chapter 2, “Managing the printer,” provides information specific to the printer, including management of paper stock and programming of the various trays.
- Chapter 3, “Managing the system,” provides management-related information that pertains to the system as a whole, such as starting, stopping, and rebooting the system and operating the tape drives.
- Chapter 4, “Maintaining the system,” provides information on adding and replacing consumable supplies, such as dry ink, and on cleaning the various areas of the system, including the tape drives.
- Chapter 5, “Troubleshooting,” provides information that will assist users in solving problems.
- Appendix A, “Supplies,” provides a summary of the paper that are used most often and the necessary supplies, their order numbers, and how to order them from Xerox.
- An index is provided at the end of this document.

## Conventions

---

This guide uses the following conventions:

- **Initial capital and angle brackets:** Within procedures, the names of keys are shown with an initial capital and within angle brackets (for example, press <Enter>).
- **Angle brackets:** Variable information, or the position of a specified argument in the command syntax, appears in angle brackets (for example, List Fonts <pattern>).
- **Fixed pitch font:** Within procedures, text and numbers that you enter are shown in a bold, fixed pitch (“computer”) font (for example, enter **privilege operator**).
- Messages that appear on the controller screen are shown in the medium weight fixed pitch font (for example, `Online Gateway disabled`).
- **The word “enter” within procedures:** The two-step process of keying in data and pressing <Enter> (for example, enter **y**).
- **Italics:** Document and library names are shown in italics (for example, the *Xerox DocuPrint NPS/IPS Guide to Managing Print Jobs*).  
Variable elements in a command or directory path are also shown in italics (for example, `var/spool/XXnps/ filename`).
- **Vertical bars:** Alternatives to specified arguments are separated by vertical bars (for example, Set Time <Time | Remote Host Name | IP Address>).



**NOTE:** *Notes are hints that help you perform a task or understand the text.*



**CAUTION:** *Cautions alert you to an action that could damage hardware or software.*



**WARNING:** *Warnings alert you to conditions that may affect the safety of people.*

## Documentation

---

This section lists related publications.

---

## DocuPrint 100/115/135/155/180 EPS documentation

---

The following documents contain information on the Xerox DocuPrint 100/115/135/155/180 EPS:

- *Customer Documentation CD*
- *Xerox DocuPrint 100/115/135/155/180 EPS Operator Guide*
- *Xerox Document Services Platform Using LCDS Print Description Language*
- *Xerox DocuPrint 100/115/135/155/180 EPS Installation Planning Guide*
- *Xerox DocuPrint 100/115/135/155/180 EPS NPS/IPS Extension Operations Guide*
- *Xerox DocuPrint EPS Font Reference Manual*
- *Xerox DocuPrint 100/115/135/155/180 EPS Operator Quick Reference Card*
- *Xerox DocuPrint 100/115/135/155/180 EPS Customer Information Quick Reference Card*
- *Xerox DocuPrint 100/115/135/155/180 EPS Job Submission Quick Reference Card*
- *Xerox Document Services Platform System Guide*





# 1 Overview

This chapter provides a functional overview of the entire system, as well as an overview of the controller and the printer portions of the system.

## Functional overview

---

The Xerox DocuPrint 100/115/135/155/180 EPS prints high quality, high resolution monochrome documents in simplex or duplex mode at high production speeds, from LCDS, PostScript, PCL, and other data streams. The system can switch between printing different types of data streams without a need for rebooting or reconfiguring software.

The printer supports:

- Duplex printing
- Media handling of multiple weights, sizes, and types
- Optional modules for enhanced finishing and output to third-party finishing devices
- Optional enabling of a third-party roll feeder
- Optional high-capacity feeder/stacker modules, which provide additional feeder trays and output bins
- High resolution of LCDS, PostScript, and PCL data streams (shown in the following table)

**Table 1-1 Data stream resolution**

<b>Data stream</b>	<b>Input resolution</b>	<b>Print resolution: DP155 and DP180</b>	<b>Print resolution: DP100, DP115, and DP135</b>
LCDS	300 by 300 dpi	600 x 2400 dpi	600 by 600 dpi
PostScript and PCL	300 by 300 dpi or 600 by 600 dpi	600 x 2400 dpi	600 by 600 dpi
IPDS*	240 by 240 dpi* or 300 by 300 dpi or 600 by 600 dpi**	600 x 2400 dpi	600 by 600 dpi

\* Requires additional equipment to enable.

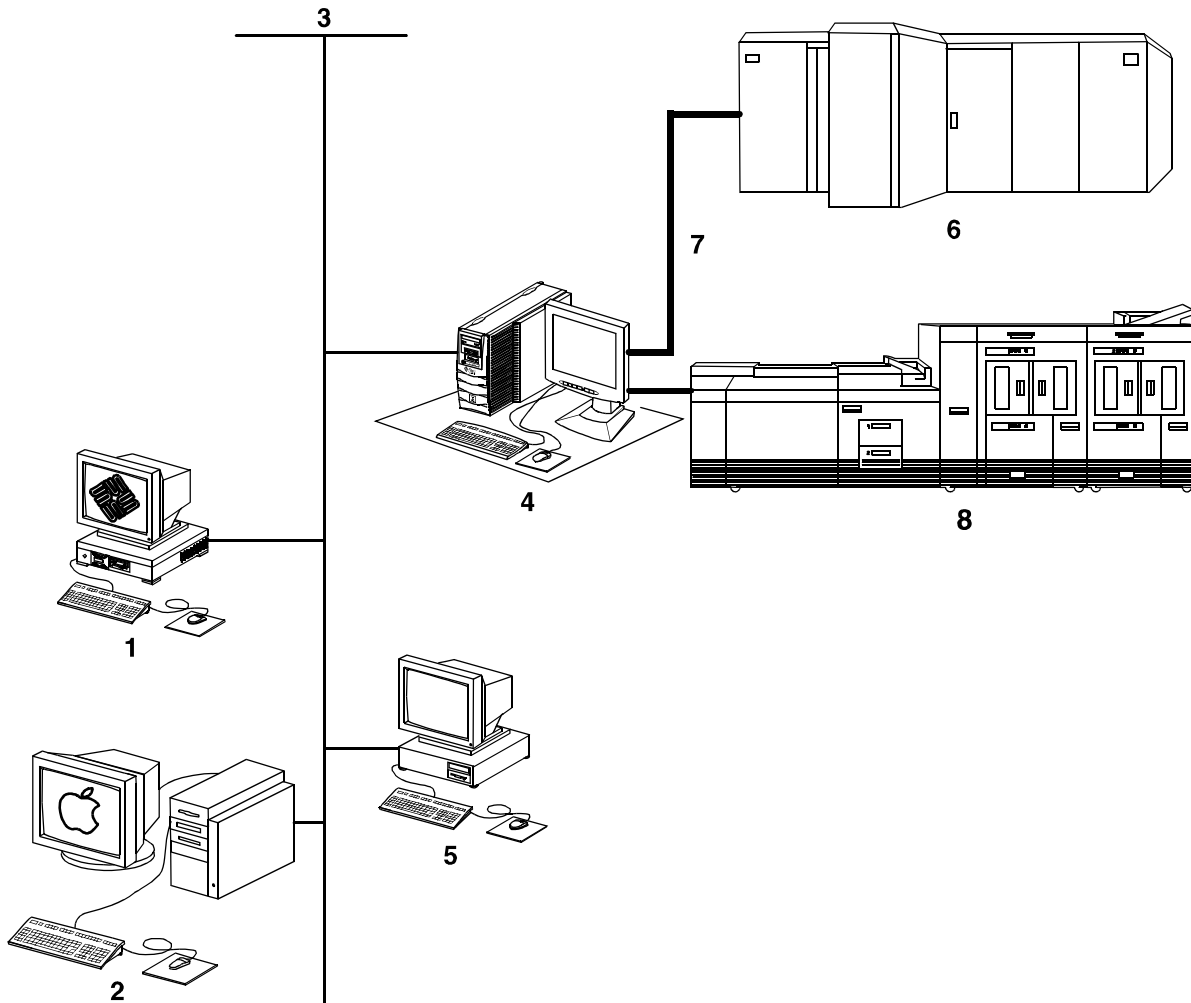
\*\* 600 by 600 dpi input resolution supported for full page IOCA only

## Host connectivity options

The Xerox DocuPrint 100/115/135/155/180 EPS can receive data from a host in the following ways:

- Over a channel with bus and tag cable connection
- Through a network interface, using Novell, TCP/IP, or AppleTalk protocols

Your system may have one or both of these configurations.



QT

**Figure 1-1 Configurations supported for the Xerox DocuPrint 100/115/135/155/180 EPS**

1. Sun UNIX client workstation
2. Apple Macintosh client workstation
3. Network connection
4. Controller
5. PC client workstation
6. Mainframe host computer
7. Bus and tag cables (channel connection)
8. Printer

---

## Data formats supported

---

The Xerox DocuPrint 100/115/135/155/180 EPS can print the following data formats:

- ASCII
- LCDS
- PCL
- PDF
- PostScript
- TIFF
- IPDS
- PPML

The system prints LCDS data from a mainframe host computer, emulating an IBM 4245 or 3211 page printer. The printing system can receive data over a channel through bus and tag cables, and through the Socket Gateway or lpr using TCP/IP protocol.

The system also prints PostScript and PCL data submitted over a network (Ethernet or AppleTalk) from a variety of clients:

- PCs (Windows and Windows NT)
- Sun workstations (UNIX)
- UNIX command line clients: lp and lpr
- NetWare Q-Server through a Novell print server (bindery mode only)
- Apple Macintosh workstations

---

## Stock specifications

---

The success of any print run depends on proper selection, care, and handling of the paper or other stock that is used. It is very important to select, store, condition, and load print media properly in order to keep your printer running at optimum efficiency.

The printer functions best and produces the best print quality when using stocks that have the correct:

- Size
- Weight
- Type
- Color

For more comprehensive information on paper stocks for Xerox printers, refer to *Helpful Facts about Paper*.

### Stock sizes

The Xerox DocuPrint 100/115/135/155/180 EPS supports the following sizes of stock:

**Table 1-2 Stock sizes**

Name of stock	Size in inches	Size in millimeters	Special requirements
<b>US Letter</b>	8.5 by 11 inches	216 by 279 mm	
<b>US Legal</b>	8.5 by 14 inches	216 by 356 mm	
<b>US Ledger US Tabloid</b>	11 by 17 inches 17 by 11 inches	279 by 432 mm 432 by 279 mm	
<b>A3</b>	11.69 by 16.54 inches	297 by 420 mm	
<b>A4</b>	8.27 by 11.69 inches	210 by 297 mm	
<b>B4 (European)</b>	9.84 by 13.89 inches	250 by 353 mm	
<b>JIS B4 (Japanese)</b>	10.12 by 14.33 inches	257 by 364 mm	
—	7 by 10 inches	178 by 254 mm	With 7 by 10 inch option kit
<b>B5</b>	7.17 by 10.12 inches	182 by 257 mm	With 7 by 10 inch option kit



**NOTE:** To feed papers smaller than 8 inches / 203.2 mm in width, a 7 by 10 inch paper option kit must be installed.

### Paper weights

The DP 100/115/135/155/180 EPS supports the following range of paper weights:

16–110 pound / 60–200 gsm

Other paper weights should not be used.



**NOTE:** The equivalent grams per square meter of 20 pound paper is actually 75 gsm. However, there is no standard 75 gsm paper. The available stock that is closest in weight to 20 pound paper is 80 gsm.

## Special stocks

---

The following special stocks can be used with the DP 100/115/135/155/180 EPS:

- **Labels:** Must be the type designed for high-speed printers and must meet the specifications described in the section above. Loading instructions are printed on all paper trays.
- **Transparencies:** Must be the type designed for high-speed printers and must meet the specifications described in the section above. Loading instructions are printed on all paper trays.
- **Colored paper:** Available in a variety of colors, colored paper has many uses, including calling attention to certain printed material, separating special sections, or dividing chapters of a report.
- **Preprinted paper:** May be letterhead, forms, or logos. (Refer to *Helpful Facts about Paper* to verify that the preprinting inks used on your stock are the kind formulated for use in laser printers.)
- **Predrilled paper:** Has holes for use in binders or binder rings. Before loading predrilled paper, fan it to remove any loose plugs that could cause paper jams.
- **Perforated paper**
- **Precut or full tabs**
- **Carbonless paper**

## General paper characteristics to look for

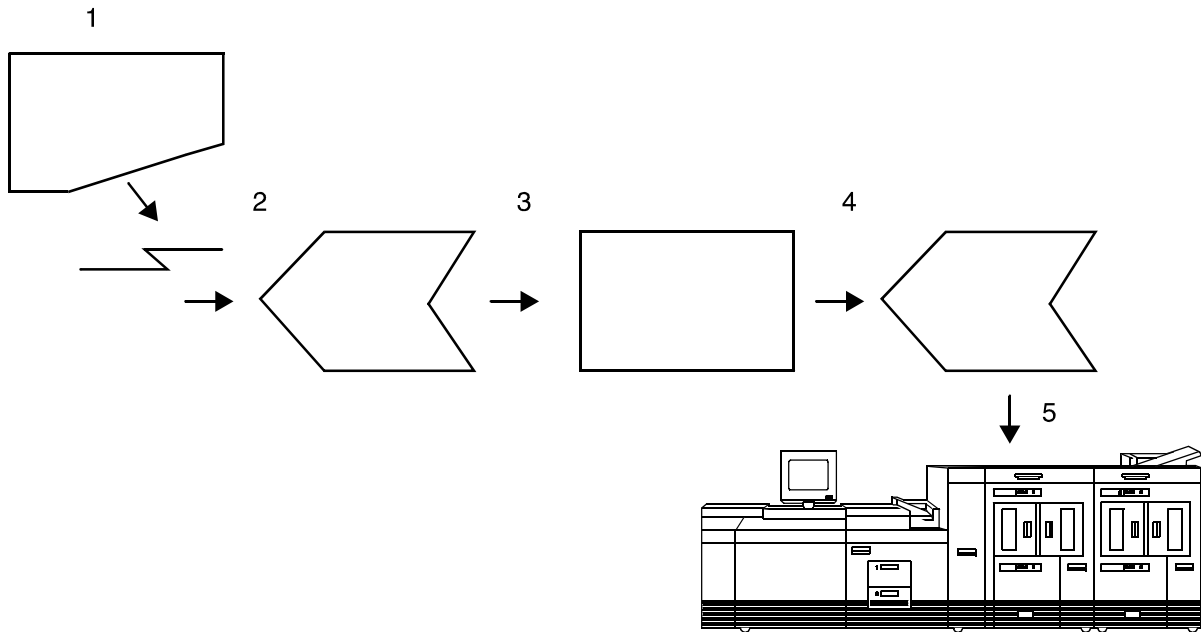
---

When selecting paper, look for the following:

- Low moisture content (a paper to moisture ratio below 5.7 percent). Paper with higher moisture content may curl and jam.
- Smooth surface
- Moisture resistant wrapping
- No defects such as bent edges or uneven surfaces
- Grain runs parallel with the long side of paper

## Printing process and job flow

This section describes how the system software processes are used as a typical job flows through the system.



**Figure 1-2 Job flow**

1. Job
2. Input Queue
3. Decomposer
4. Output queue
5. Printer

Refer to the Job Flow diagram above for the following work flow process.

1. **Job:** The job and the job ticket (if applicable) are received from the network by one of the protocol gateways.
2. **Input queue:** The Job Pool Manager (JPM) process transfers the job into the input queue. The virtual printer name and job attributes are attached to the job. The job remains in the Input Queue until it can be printed; for example, “held” and “faulted” jobs reside in the input queue.
3. **Decomposer:** The Job Chooser (DC process) reconciles the job attributes with the virtual printer attributes. Once the job is ready for print, the Job Chooser gives the job to the appropriate decomposer (ps\_cdf process, pcl\_cdf process).
4. **Output queue:** After decomposition, the job is stored in the output queue.
5. **Printer:** The marker (marker process) transfers the job from the Output Queue to the Image Output Terminal (IOT or

printer). After the job has successfully printed, it is removed from the Output Queue and also from the Input Queue, if the Input Property for the queue is set to spool.

The `ps -e` or `ps -ef` commands can be used to list the system software processes. A varying process identification number is listed along with each process.

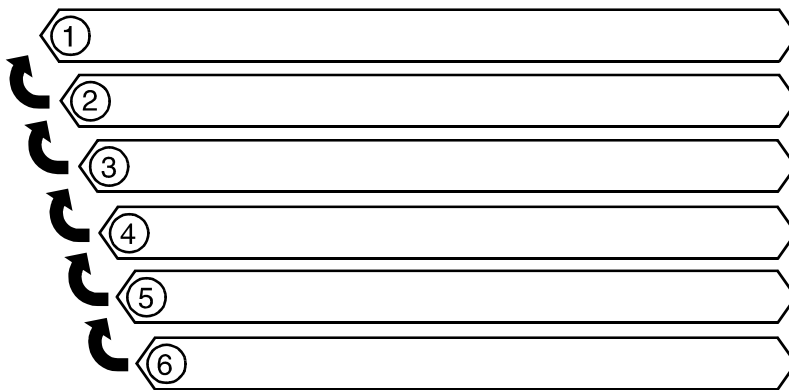


**NOTE:** *The printing process and job flow is different for PostScript, PCL, TIFF, ASCII, PDF jobs (that is, non-LCDS jobs) and for LCDS jobs.*

### **PostScript, PCL, TIFF, ASCII, and PDF jobs**

When the job is sent from the application for printing, a print data file is created. This file becomes the job that is submitted to the printer for printing. The print data file and the job request are submitted to the selected queue. Jobs are processed by priority within the designated queue once the job reaches the queue from a given application.

The following graphic illustrates the priority that each setting has in printing the job. For example, queue override settings in a job take precedence over exception page or job ticket settings.



**Figure 1-3 Submission and print order of jobs in a queue**

1. Queue overrides
2. Exception pages
3. Job ticket
4. Submission print protocol (`lp`, `lpr`, `nprint`)
5. Set page device values/PCL copy count
6. Queue defaults

You can make changes to the printing attributes of a PostScript, PCL, TIFF, ASCII, and PDF job (that is, a non-LCDS job), as long as the job is not streaming. This includes changing the type of paper on which it is printed or specifying printing order from last page to first (N to 1).

## Printer overview

---

The printer receives data from the controller and prints the document according to the print options specified by the user. The printer also stacks the printed output, collates it, and, if configured with one of the available optional third-party finishing devices, performs finishing functions such as binding, stitching, or perforating.

The Xerox DocuPrint 100/115/135/155/180 EPS printer is a monochrome printer. If it receives print jobs that contain color commands, it prints them in black or shades of gray.

### Throughput speeds

The Xerox DocuPrint 100/115/135/155/180 EPS prints LCDS data from a mainframe host computer, emulating an IBM 4245 or 3211 line printer. The printing system can receive data over a channel through bus and tag cables and through the Socket Gateway or `lpr` using TCP/IP.



**Table 1-3 Throughput speeds**

Printing system	Maximum throughput	Maximum throughput with 7 by 10 in / 178 by 254 mm paper
DP100 EPS	100 ppm	100 ppm
DP115 EPS	115 ppm	115 ppm
DP135 EPS	135 ppm	154 ppm
DP155 EPS	155 ppm	155 ppm
DP180 EPS	180 ppm	206 ppm



**NOTE:** Pages per minute refers to sides of a printed sheet (actually impressions per minute).

Using the smaller papers, such as 7 by 10 inch / 178 by 254 mm or B5, the printer can print at maximum speed. To print these sizes, the printer requires the optional small paper kit.

### Monthly print volume

The monthly print volume for the Xerox DocuPrint Enterprise Printing Systems is up to 6 million impressions.

**Table 1-4 Minimum and Maximum monthly print volume**

Printing system	Minimum	Maximum
DP100 EPS	800 thousand	3 million
DP115 EPS	1 million	3.5 million
DP135 EPS	1.2 million	4 million
DP155 EPS	1.4 million	4.5 million
DP180 EPS	1.8 million	6 million

### Roll feeder support

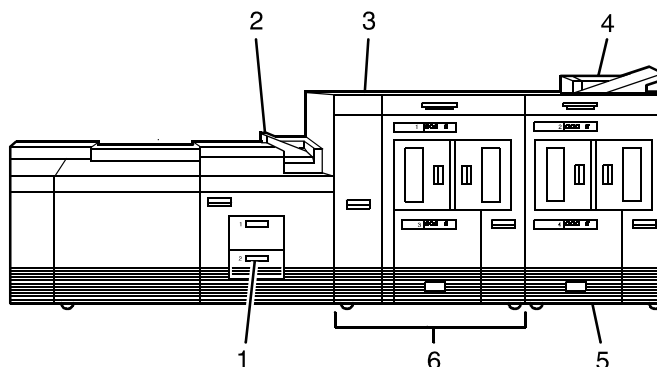
The roll feeder option may be installed in the inverter feeder/stacker module, replacing the feeder tray. This option does not require DFA software or any additional hardware. The maximum number of feeder/stacker modules supported for this configuration is four, including the inverter module with the roll feeder. With the two processor feeder trays, this makes a total of six input trays possible.

### Jam recovery

The printer engine monitors the print job so that, if a paper jam occurs, the job resumes on the correct page, at the correct tab, using the same color paper, and so forth, providing complete document integrity.

## Printer components

The components and special features of the Xerox DocuPrint 100/115/135/155/180 EPS printer are shown in the following figure.



**Figure 1-4 Printer components**

1. Processor feeder trays
2. Sample tray
3. Attention light
4. Purge tray
5. Feeder/stacker module
6. Inverter feeder/stacker



**NOTE:** Some printer configurations may include a control console (not shown).

### Processor Feeder Trays

Two processor feeder trays (trays 1 and 2) are located in the main part of the printer and are not part of a feeder/stacker module.

Trays 1 and 2 can handle paper sized from 8 by 10 inches / 203 by 254 mm to 9.02 by 14.02 inches / 230 by 356 mm.

### Sample tray

The sample tray, located on top of the printer, receives output such as transparencies, sample sheets from printing jobs, prints from system files such as forms, and waste sheets that cannot be sent to the purge tray.

Monitor the sample tray and empty it when it contains 100 sheets.



**NOTE:** The system does not notify you when the tray is full.

## Attention light

An Attention light is mounted on top of the inverter module. This light either blinks or modulates (alternately brightens and dims) when the printer requires operator attention. The light has three states:

- **Off:** No printer problems exist that require attention.
- **Steady light:** A situation exists that needs attention soon.
- **Flashing:** The printer has stopped and requires your attention immediately.



**NOTE:** *When the Attention light starts flashing, an explanatory message appears in the Console window on the controller screen.*

## Purge tray

The purge tray is located on top of the last feeder/stacker module. Aborted sheets (for example, damaged sheets or sheets cleared after a paper jam) are sent to this tray. The purge tray should be emptied when it has received 100 sheets of paper.



**NOTE:** *The system does not notify you when the tray is full.*

## Feeder trays

Multiple feeder trays can be configured to feed paper for jobs in the most effective manner. For example, the trays can provide nonstop printing of a complex job that requires many paper stocks, or only a few stocks, by using the trays continuous loading capability. A different input tray can also be selected for each copy of a specific page in a print job, for example, to provide different paper colors for specific pages.

The printing system may have up to six feeder trays: two processor feeder trays and two to four high-capacity trays. Four addressable input trays are standard with the system, and two additional high-capacity trays are optional.

### Feeder tray capacity

The feeder trays have the following capacities, based on 20 pound or 80 gsm (grams per square meter) paper:

- **Tray 1:** 1100 sheets
- **Tray 2:** 600 sheets
- **Trays 3, 4, 5, and 6 (high-capacity trays):** 2600 sheets each

An elevator moves each tray up or down when it is in use. In each tray, a control panel consisting of a button, indicators, and paper level displays controls the elevator tray and indicates its status.

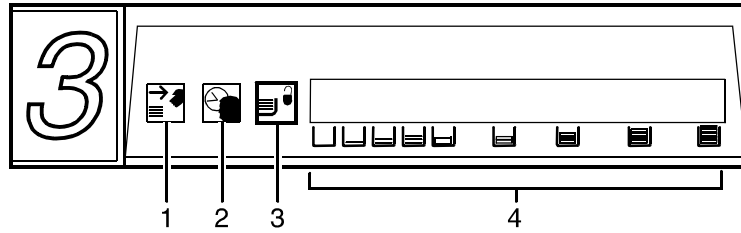


Figure 1-5 Feeder tray control panel

1. Ready to Open indicator on feeder trays
2. Please Wait indicator on feeder trays
3. Tray Unlock button (feeder)
4. Paper Level indicators on feeder trays

**Ready to Open indicator on feeder trays**

Glows green when the tray can be pulled out and paper can be added to it.

**Please Wait indicator on feeder trays**

Shows that the tray is in motion. This indicator is lit red when the Tray Unlock button is pressed, while the tray is lowering, and while the tray is rising. The indicator goes off when the tray elevator reaches its destination.

**Tray Unlock button (feeder)**

Enables the feeder tray to be opened.

- If the tray is in use when this button is pressed, the feed selection switches to the backup tray if one has been identified. Otherwise, printing stops.
- If the tray is in use and selected as a backup tray, pressing the Tray Unlock button causes the tray elevator to lower and the tray to be unavailable for auto switching.
- If the tray elevator is in the raised position and the tray is not in use or selected as a backup tray, pressing this button causes the elevator to lower with no effect on printing operations.

This button functions when the Please Wait indicator is off.

**Paper Level indicators on feeder trays**

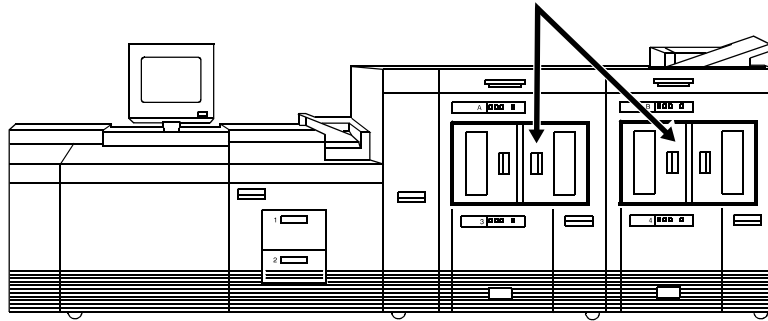
Display the approximate quantity of paper in the tray. Each display shows paper by quarter reams up to one ream, and then by full reams. The green indicator appears above its Paper Level indicator.

**Stacker bins**

Each output stacker bin has offsetting capability and a capacity of 2500 sheets of 20 pound or 80 gsm paper.



**NOTE:** *This capacity does not apply to 11 by 17 inch and A3 papers. Because of the additional weight these large sheets add to the bins, each bin is restricted to hold only up to 1500 sheets of A3 or 11 by 17 inch papers, for safety reasons.*



**Figure 1-6 High capacity stackers (HCS)**

The stackers can stack the printed output in the bin three ways:

- Directly onto the bin platform.
- Into a container that is set on top of the bin platform.



**NOTE:** *The stacking capacity is approximately 100 to 150 sheets less when stacking into a container.*

- Onto a pallet without a container (for paper sizes 11 by 17 inches or A3 only).

Using the Stacking windows on the user interface, you can select the level to which paper will be stacked in the HCS.

A stacking elevator maintains the paper at the proper level for stacking and lowers the stack for unloading. An offset mechanism offsets printed sets toward the front or back of the HCS bin.

The elevator platform lowers under the following conditions:

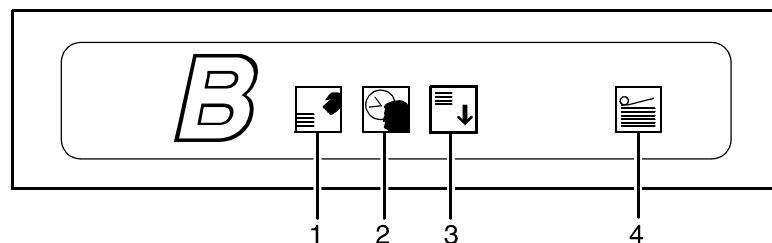
- The bin capacity has been reached.
- A selection to lower the platform is entered at the printer control console or a user interface window.
- The job being printed reaches a designated unload boundary.

Each HCS bin has unlinked double doors to give you easy and safe access for unloading output from the printer.

The elevator bin platform automatically rises when the doors are closed after the stacker has been unloaded.

Each stacker bin has a control panel consisting of buttons and indicators.

### Bin control panels on stackers



**Figure 1-7 High capacity stacker bin control panel**

#### 1. Ready to Unload indicator on stacker bins

2. **Please Wait indicator on stacker bins**
3. **Bin Unload button on stacker**
4. **In Use indicator on stacker bin**

<b>Ready to Unload indicator on stacker bins</b>	When this indicator glows, you can remove printed sheets from the stacker bin.
<b>Please Wait indicator on stacker bins</b>	When this indicator glows, the elevator is in motion. This indicator turns off when the platform reaches its destination.
<b>Bin Unload button on stacker</b>	Lowers the bin elevator. <ul style="list-style-type: none"><li>• If the bin is in use when this button is pressed, the printed pages begin stacking in the other stacker bin, if auto switching has been enabled.</li><li>• If the bin is not in use, pressing this button does not affect printing operations.</li></ul>
<b>In Use indicator on stacker bin</b>	When this indicator glows, the bin has been made ready to receive output.

## Feeder/stacker modules

---

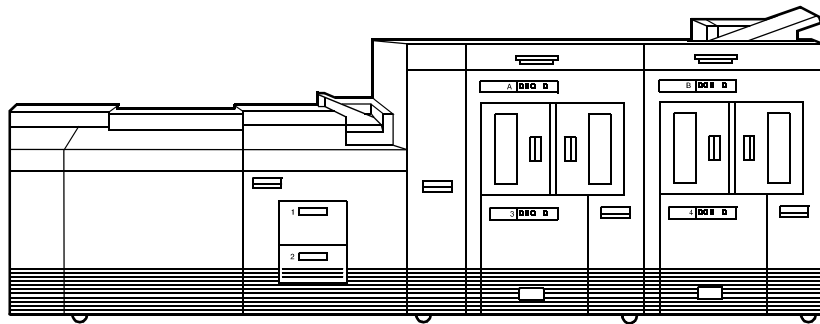
	The feeder/stacker modules contain the high-capacity feeder trays and the stacker bins. The printer may have up to four feeder/stacker modules (including the inverter feeder/stacker), containing feeder trays 3, 4, 5, and 6, and stacker bins A, B, C, and D. Each module contains one high-capacity feeder tray and one high capacity stacker bin.
<b>High-capacity feeders</b>	<p>The high-capacity feeder (HCF) trays are located in the bottom half of the feeder/stacker modules. Each HCF tray can hold up to 2500 sheets of 20 pound or 80 gsm paper.</p> <p>The high-capacity feeder trays can handle paper sized from 8 by 10 inches / 203 by 254 mm to 17 by 14.02 inches / 432 by 356 mm.</p> <p>Unlike the processor feeder trays, the HCF trays have Paper Level switches, which detect the position of the elevator to determine the fullness of the tray.</p>
<b>High-capacity stackers</b>	<p>The high-capacity stacker (HCS) bins are located in the top half of the feeder/stacker modules, accessed through double doors.</p> <p>Two high-capacity stacker bins are standard, with up to two additional bins available as options (providing up to four bins total). Each bin holds up to 2500 sheets of 20 pound or 80 gsm paper.</p>
<b>Inverter</b>	The inverter is part of the inverter feeder/stacker module. It allows for proper collation of the print job. It also directs printed output to the sample tray, when required.

## Printer control console (not shown)

Where available, the printer control console is the color monitor located on top of the printer. It keeps you informed of the printer status, and enables you to control certain functions of the printer, such as stopping printing and continuing an interrupted job, without returning to the controller.

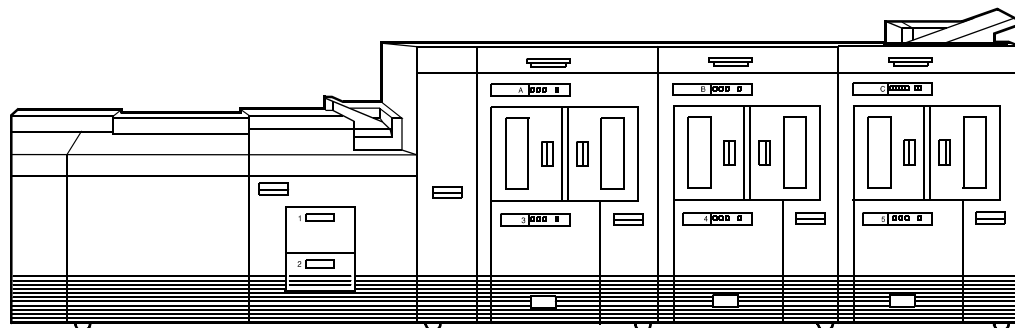
## Printer configurations

The standard printer configuration consists of an inverter feeder/stacker plus one additional feeder/stacker. Some configurations may include a printer control console (not shown).

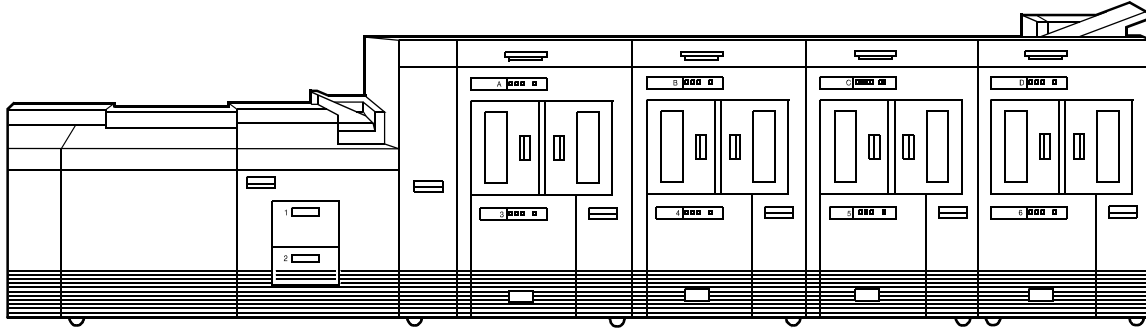


**Figure 1-8 Printer with inverter feeder/stacker + feeder/stacker (standard base configuration)**

In addition, the printer is available with three or four feeder/stacker modules.



**Figure 1-9 Printer with inverter feeder/stacker + feeder/stacker + feeder/stacker**



**Figure 1-10 Printer with inverter feeder/stacker + feeder/stacker + feeder/stacker + feeder/stacker**



**NOTE:** *The bypass transport device is not available for this configuration (four feeder/stacker modules).*

## Printer options

---

The printing system is available in several configurations, and may be connected to a bypass transport.

### Bypass transport

---

The bypass transport option enables third-party finishing devices to interface directly with the printing system. The bypass transport allows you to customize your printer for increased efficiency and specialized applications involving finishing.

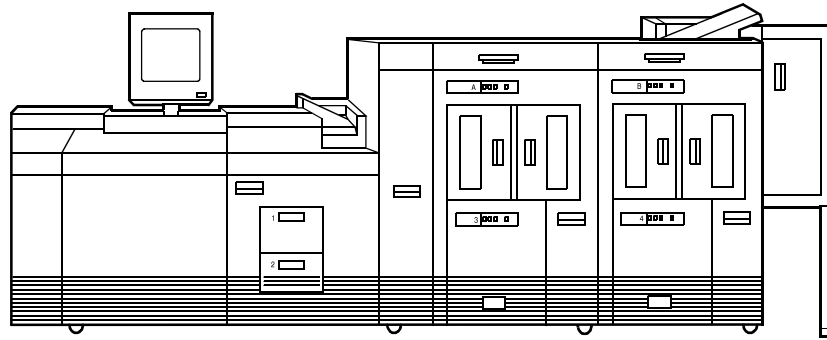


**NOTE:** *A bypass transport must be installed for the printing system to support a third-party finishing device.*

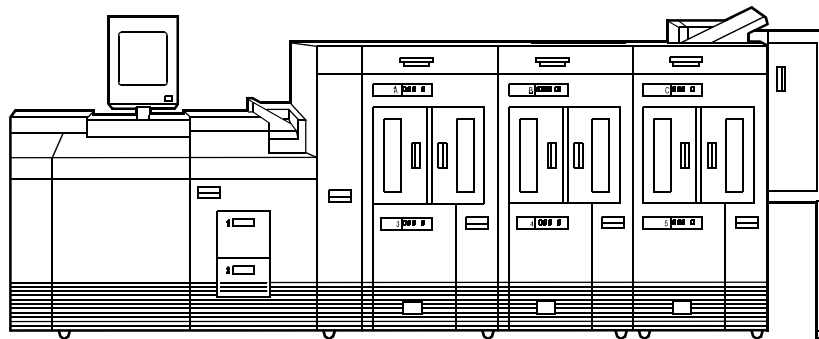
#### Function of the bypass transport

Connected to the last feeder/stacker module, the bypass transport moves paper from the stacker to a third-party finisher such as a stitcher, booklet maker, tape binder, and so on. By making selections on the display monitor, you can program the printer to send output to the bypass transport, which feeds the output to the finishing equipment.





**Figure 1-11 Printer with inverter feeder/stacker + feeder/stacker + bypass transport**



**Figure 1-12 Printer with inverter feeder/stacker + feeder/stacker + feeder/stacker + bypass transport**

The illustrations above show a printer with two feeder/stacker modules and a bypass transport, and a printer with three feeder/stacker modules and a bypass transport. With the bypass transport installed, the printer can support up to three feeder/stacker modules, including the inverter feeder/stacker.

The bypass transport accepts all paper stocks on which the printer can print, and it accommodates simplex and duplex printing.

The bypass transport meets the Xerox Document Feeding and Finishing Architecture (DFA) specifications. The system software supports DFA. However, in order for the bypass transport to function correctly, you need to set up finishing personality profiles to identify your finishing device to the printing system. (The customer support representative for your finishing device can give you the information you need to create a personality profile for your third-party finishing device.)

**Paper stocks supported on bypass transport**  
**DFA support**

### **Support and interface with feeders**

For information on marketing partners that provide solutions for support and interface with feeders, contact your local Xerox sales representative.

The input enablement device is NOT an option on the Xerox DocuPrint 155 and 180 EPS.



**NOTE:** *The input enablement device is available only for the Xerox DocuPrint 100, 115, and 135 EPS.*

### **7 by 10 inch enablement kit**

---

The 7 by 10 inch enablement kit allows the printing system to print on 7 by 10 inch/178 by 254 mm paper size, with throughput speed of up to 206 PPM.

## **Paper paths**

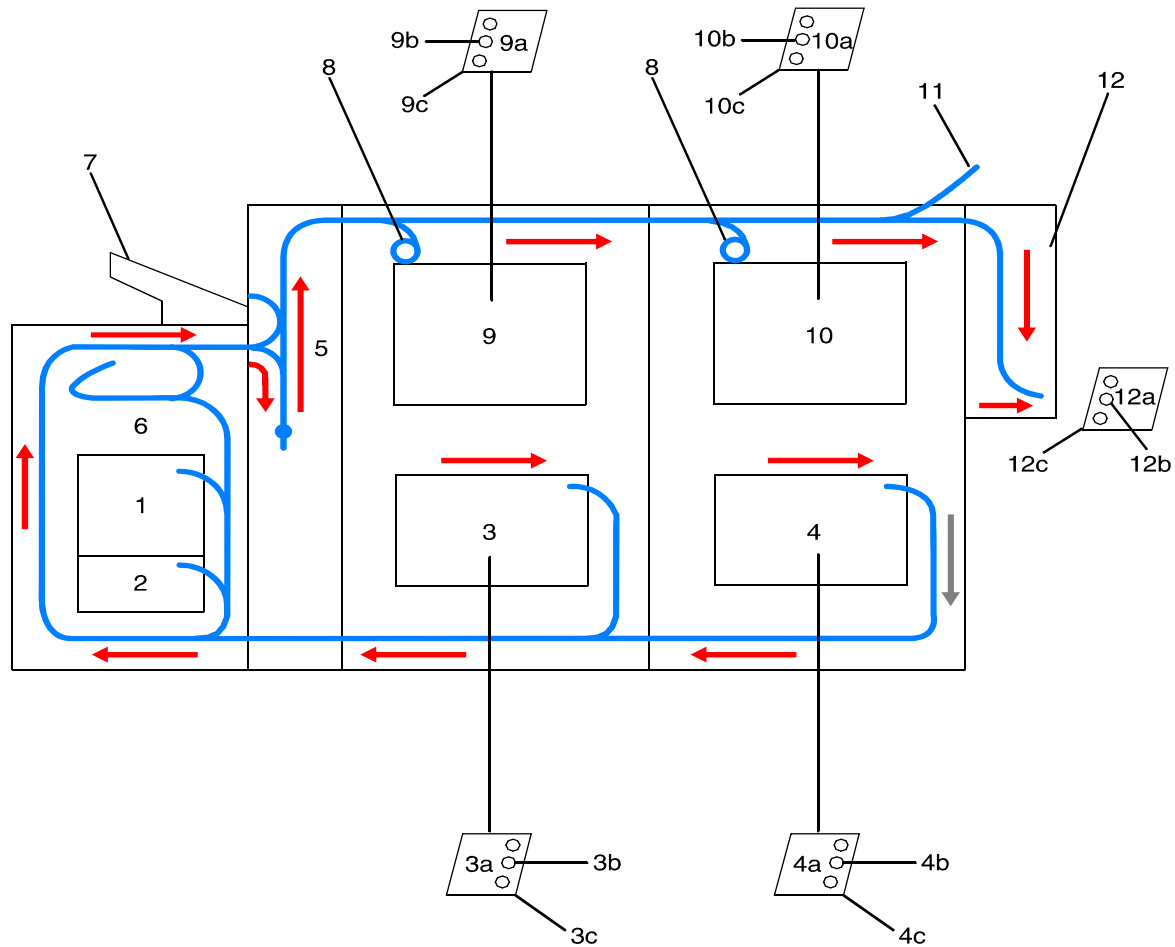
---

The paper path is the route that materials (paper, transparencies, labels, and so on) follow through the printer from the feeder trays to the output bins or finisher.

### **Printer paper path**

---

The following figure shows the path the paper takes through the printer.



**Figure 1-13 Route of paper through the printer**

1. Processor feeder tray 1
2. Processor feeder tray 2
3. High-capacity feeder tray 3
  - a. Side 1 of sheet leaving feeder tray
  - b. Drilled holes (on right edge)
  - c. Origin 0,0: portrait orientation
4. High-capacity feeder tray 4
  - a. Side 1 of sheet leaving feeder tray
  - b. Drilled holes (on right edge)
  - c. Origin 0,0: portrait orientation
5. Inverter
6. Duplex inverter
7. Sample tray
8. Disk inversion
9. High-capacity stacker bin A
  - a. Side 2 of sheet stacked in bin
  - b. Drilled holes (on left edge)
  - c. Origin 0,0: portrait orientation
10. High-capacity stacker bin B
  - a. Side 2 of sheet stacked in bin
  - b. Drilled holes (on left edge)
  - c. Origin 0,0: portrait orientation

11. Purge tray
12. Bypass transport
  - a. Side 2 of sheet passing through bypass transport
  - b. Drilled holes (on left edge)
  - c. Origin 0,0: portrait orientation

### Bypass transport paper path

The following figure shows the paper path through the bypass transport, viewed from the front of the printer.

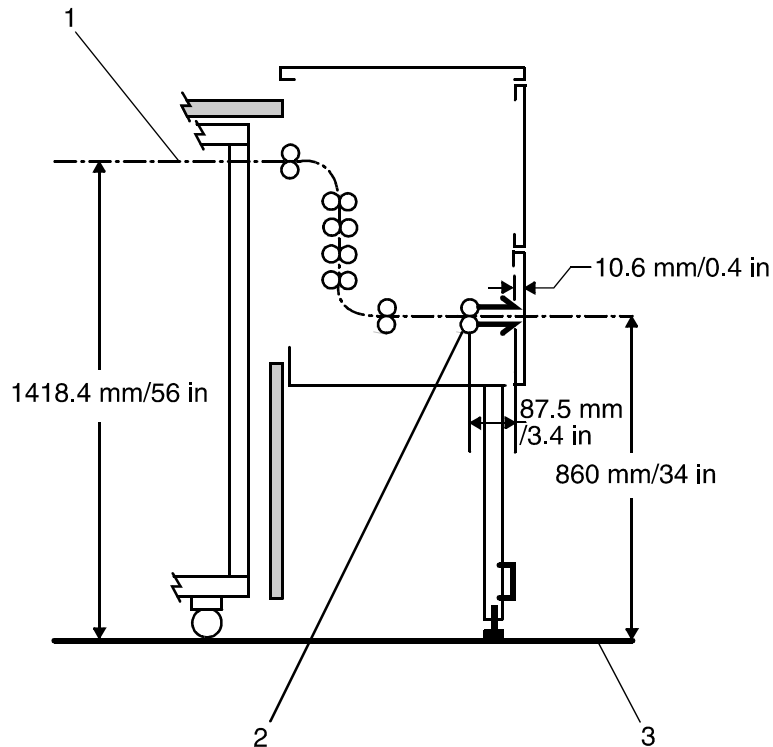


Figure 1-14 Bypass transport paper path

1. Sheet path
2. Exit rollers
3. Floor

## Controller overview

The controller receives LCDS, PostScript, and PCL data streams from a mainframe host or a workstation client, processes the data, and sends it to the printer. The controller also provides the printer with print data and commands and receives status information from the printer.

The controller consists of a Sun Workstation computer, which is run by the Sun Solaris Operating environment. Also resident on the controller is the Document Services Platform application

### Accessing DocuSP remotely (Remote Workflow)

software, known as DocuSP software, which manages all printing, diagnostic, and administrative functions on the printing system.

The DocuSP software includes a full-color graphical user interface, which enables you to interact with the printing system to set up and configure the system, to set up and implement system options, to run print jobs, etc.

Online Help (menus and buttons) provides access to online help that contains information when requested.

Remote Workflow, a remote graphical user interface (GUI), is available for installation from a CD. Remote Workflow allows you to manage your DocuSP-based printers from a single PC or Sun workstation. You may set your preferences from the remote client to disable or enable some or all connections.

Remote Workflow allows you to configure the printers that you want to manage, and provides real time status of the printers. You may switch between the printers that you are managing, but you can display only one printer GUI at a time.

The remote client GUI looks and functions the same as the local DocuSP GUI on the controller.

## Controller components

---

The controller consists of a specially-configured Sun workstation and uses proprietary Xerox hardware, firmware, and software. Your controller has one of two possible configurations, described in the following sections.

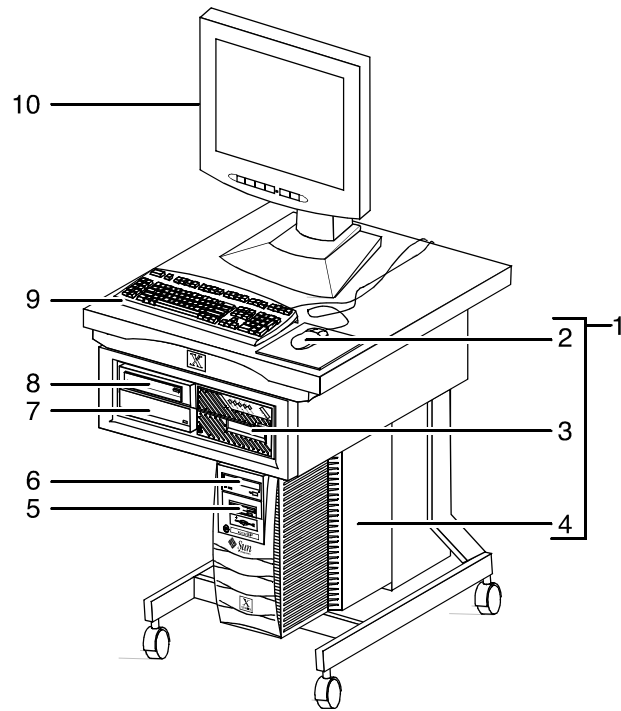


**NOTE:** *Controller hardware configurations are subject to change, to keep up with technology advances.*

### Sun workstation

---

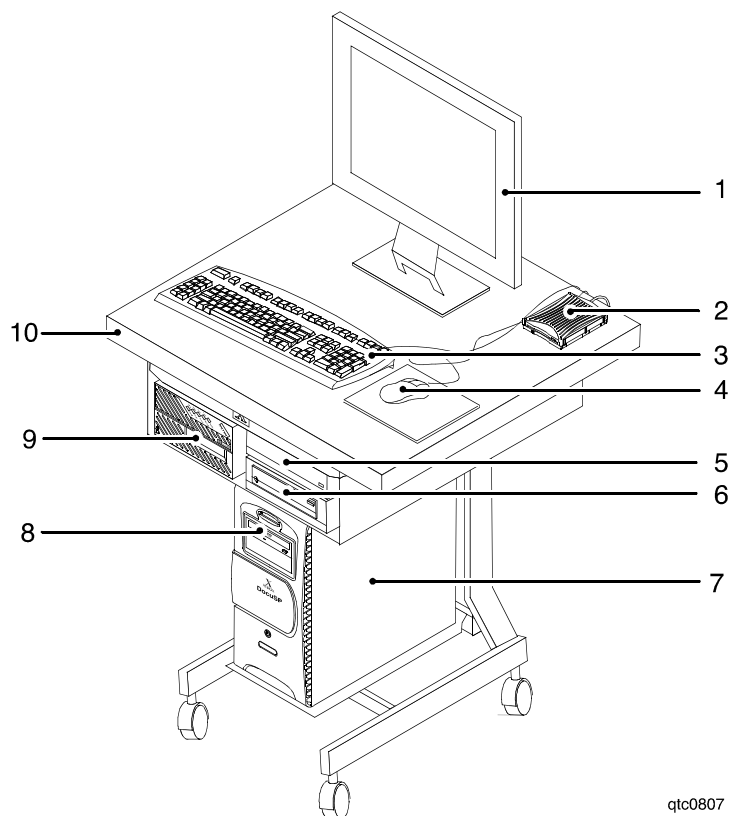
The controller is based on either the Sun Blade 1000/2000, Sun Blade 2500 or the Sun W1100z workstations with high-performance architecture for complex processing tasks.



qtc0707

**Figure 1-15 Sun Blade 1000/2000**

- 1. Controller stand**
- 2. Mouse**
- 3. 18/36-track cartridge tape drive (optional)**
- 4. Processor**
- 5. Diskette drive**
- 6. CD drive**
- 7. Quarter-inch cartridge (QIC) tape drive**
- 8. External fixed disk drive (optional)**
- 9. Keyboard**
- 10. Display monitor**



qtc0807

**Figure 1-16 Sun Blade 2500 or Sun W1100z controller**

1. Display monitor
2. External diskette drive
3. Keyboard
4. Mouse
5. External fixed disk drive (optional)
6. Quarter-inch cartridge (QIC) tape drive
7. Processor
8. DVD/CD-RW drive
9. 18/36-track cartridge tape drive (optional)
10. Controller stand

The Sun workstation controller may contain the following hardware components:

- Processor (system unit) containing the following:
  - One or two UltraSPARC high-speed processing unit (CPU) modules
  - One or two 1-GB memory modules
  - **Note:** *In Xerox Europe, all printers use a 2 GB memory configuration.*
  - Hard disk drive
  - CD or DVD/CD-RW drive
  - Diskette drive (Sun Blade 1000/2000 only)
  - Ethernet
  - One or two Printer Controller Interface (PCI) boards to interface with the printer
  - Video graphics board
  - Universal Serial Bus (USB) keyboard and three-button mouse
  - 17-inch flat panel monitor
  - External diskette drive (Sun Blade 2500 only)



## Processor

The central processing unit may contain the memory, internal disk drive, a graphics board, a DVD-ROM drive, a diskette drive, power receptacle and outlet, connectors, and ports.

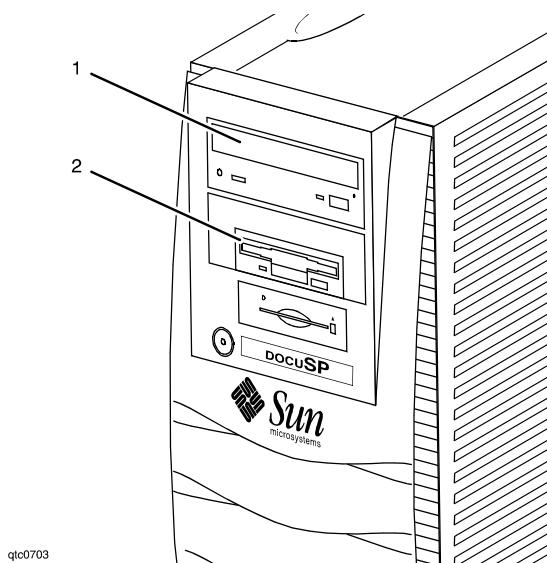
- **Memory:** One or two 1-GB Dual In-line Memory Modules, or DIMMs, are provided as a standard feature of the processor.
- **Hard disk drive:** The internal hard disk drive stores the operating system software, the NPS/IPS Extension application, and any queued print jobs are stored on the internal disk. This disk cannot be used to store other applications or data except as directed by your service representative.
- **Diskette drive:** Diskettes are used to install fonts and to load files to, and back up files from, the internal disk drive. The diskette drive uses industry standard 3.5 inch, 1.44 MB, double-sided, high-density diskettes.



**NOTE:** *The diskette drive is external, and plugs into the processor back panel.*

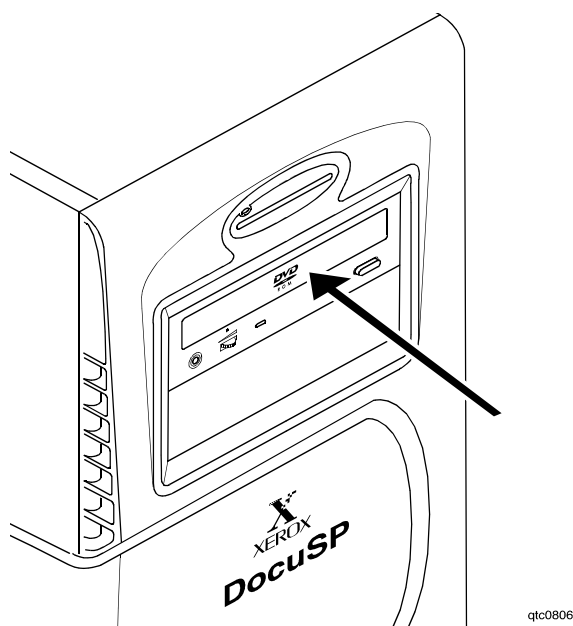
- **DVD-ROM drive:** The DVD-ROM drive is a high density, read-only, optical laser storage device used for loading the NPS/IPS operating system and other files. The DVD-ROM drive is located in the processor above the diskette drive.





**Figure 1-17 Drive locations on Sun Blade 1000/2000**

1. CD drive
2. Diskette drive



**Figure 1-18 DVD/CD-RW drive location on the Sun Blade 2500 or or Sun W1100z**

- **Back panel:** The back panel of the processor has a power receptacle and outlet, connectors, connector openings, ports, fan, and vent.

## Keyboard

The keyboard consists of alphanumeric keys similar to a typewriter, symbols and special character keys, an extended character set, and function keys. The keyboard is one of your main methods of communicating with the printer. You can use the keyboard to make selections, and to enter commands that control

	functions such as requesting sample prints, or shutting down the system.
<b>Mouse</b>	The mouse is another main method of communicating with the printer.
<b>Display monitor</b>	The LCD monitor allows you to interact with the printer and to monitor its interaction with the various components. During a print job, printer error messages may display to notify you of any unexpected conditions.
<b>Optional processor components</b>	<p>The controller may be configured with any of the following optional components:</p> <ul style="list-style-type: none"><li>• Connectivity board to enable Token Ring</li><li>• Channel interface board for channel connection to a host for online LCDS printing</li><li>• One SCSI board to connect to an external tape drive</li><li>• Creator-3D series 3 graphics board (may replace the video graphics board delivered with the controller)</li></ul>

## External components and options

---

The following components are external to the processor. The controller stand contains sections that may hold these components.

- Quarter-inch cartridge (QIC) tape drive
- 36-track cartridge tape drive (optional)
- External 36 GB hard disk drive (optional)



**NOTE:** *This additional drive is standard equipment on systems with the NPS/IPS extension.*

## Controller stand

---

The controller is provided with a special stand that holds all its standard components. In addition to the processor, keyboard with the mouse, and the quarter-inch cartridge tape drive, the stand can accommodate the optional 36-track tape drive and one external hard disk drive (required for the NPS/IPS Extension option).

## Online and offline interfaces

---

### Online interface

The Xerox DocuPrint 100/115/135/155/180 EPS may be configured for either the online interface, the offline interface, or both.

The online (channel-attached) interface receives input directly from any environment that supports the IBM 3211 and 4245 host systems.

## Offline interface

The Xerox DocuPrint 100/115/135/155/180 EPS supports three types of peripheral devices from which you can import resource files such as forms, fonts, and JSLs, and receive print data from tape. These devices are called “peripheral” because they handle media external to the system disk.

The following drives are supported:

- 26-track cartridge tape drive (QIC)
- 9-track reel tape drives
- 36-track cartridge tape drives

## Moving the controller

To ensure consistent performance and avoid any damage to equipment, follow these rules for placing the components of the workstation controller:

- Use the controller stand that comes with your printing system equipment.
- Keep the processor in an upright, vertical position as illustrated below.
- Allow at least 6 inches / 152 mm of unobstructed space at the front and rear of the processor, so the fan and vents are not blocked.

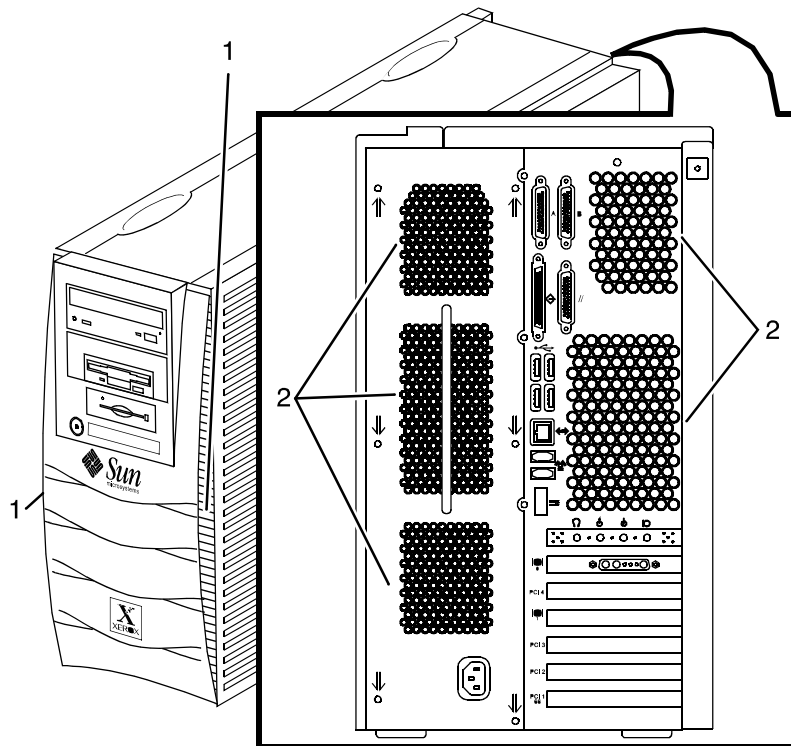
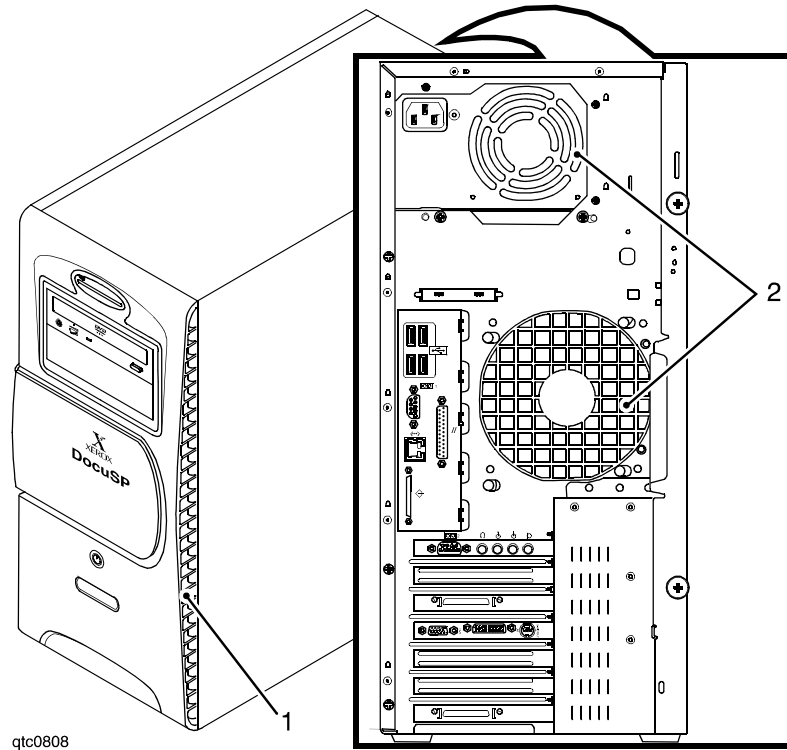


Figure 1-19 Sun Blade 1000/2000 fan/vent locations to keep clear

1. Vents in front of processor
2. Vents in back of processor



**Figure 1-20 Sun Blade 2500 and Sun W1100z common fan and vent locations to keep clear**

1. Vents in front of processor
2. Vents in back of processor



**CAUTION:** *Do not place the monitor on top of the processor. Do not block any fan or vent on the front, sides, or rear of the processor.*

**Do not:**

- Do not place the monitor and processor on a desk or table top.
- Do not place the monitor on top of the processor.
- Do not allow any piece of equipment to blow warm air into the air intake vents of the processor.
- Do not place the processor on its side, or in any other position but the upright, vertical position achieved by using the controller stand.
- Do not place the processor or monitor on top of the printer.

## Tape drives overview

The DocuPrint 100/115/135/155/180 EPS supports several types of tape drives that may be used to load resources (forms, fonts, etc.) or to submit offline LCDS print jobs.

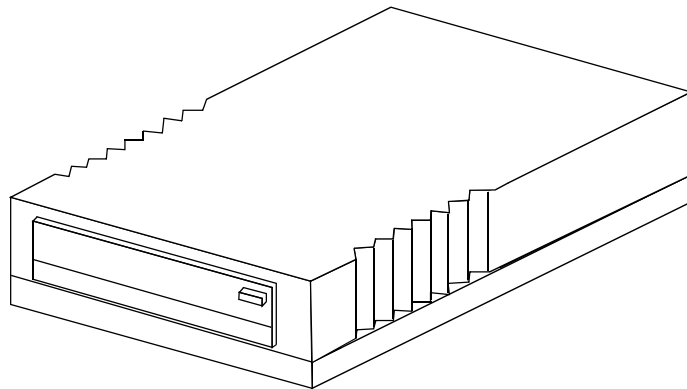
The 26-track cartridge tape drive, provided with your Xerox DocuPrint 100/115/135/155/180 EPS, can be used only to import resources to the system disk. 9-track and 36-track tape drives can be used to submit print jobs to the DocuPrint EPS, or load resources.

The DocuSP Tape Client software enables transmission of data from a cartridge or open reel tape to the DocuPrint EPS controller via the Socket gateway.

### 26-track cartridge tape drive (QIC) (for resource loading only)

The 4 GB external SCSI quarter inch cartridge (QIC) tape drive is an external device provided with the Xerox DocuPrint 100/115/135/155/180 EPS. The cartridge tape drive connects to the controller through the SCSI port on the processor back panel.

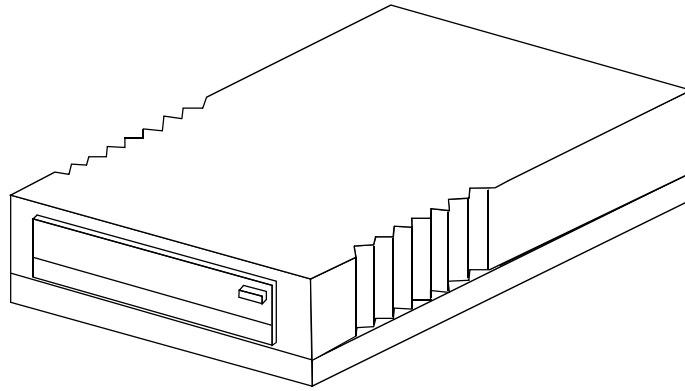
Like the diskette and DVD drives, this tape drive is not an input source for print jobs or for any other data or application. You can use it to load resource files, and the service representative uses it to load system maintenance files or to save diagnostic information.



**Figure 1-21 26-track cartridge tape drive (QIC)**

### 36-track cartridge tape drive

An 18/36-track cartridge tape drive is an option. You can use this drive to load resources and to submit offline LCDS print jobs.

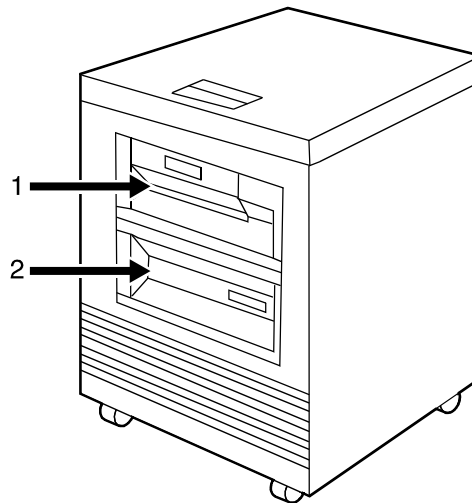


**Figure 1-22 18/36-track cartridge tape drive**

**Peripheral cabinet  
(9-track and 18/36-  
track tape drives)**

Some Xerox customers may already have a peripheral cabinet that houses a 9-track magnetic and an 18/36-track cartridge tape drive. The DP EPS supports existing peripheral cabinets, but they are not available with new systems. In addition, if a peripheral cabinet has either of the following 18-track tape drives, they are not supported:

- STK 4220 MOD 1 tape drive
- STK 4220 MOD 2 tape drive



**Figure 1-23 Peripheral cabinet**

1. 9-track magnetic tape drive
2. 18/36-track cartridge tape drive

---

## Paper sizing and print speed

---

The printer paper trays have edge guide sensors that detect paper length and width. The system selects correct paper trays for the print job based on the paper size specified in the job, as follows:

- If an exact match is found, the print job continues.
- If an exact match is not found, the programmer can specify in the job for the printer to do one of the following:
  - Stop printing the job and print an error sheet.
  - Print the data on an oversized sheet.

If you encounter any problems related to paper sizing, contact your lead operator or Xerox service representative.

## Long and short edge feeding

To feed through the printer, the leading edge of the paper must be at least 10 inches long. Therefore, the following standard sizes of paper must be loaded so that sheets feed long edge first:

- 7 by 10 inch
- B5
- A4
- US Letter
- B4
- US Legal

The following papers, which have long edges greater than 14.33 inches / 364 mm must feed short edge first:

- A3
- US Ledger or US Tabloid



**NOTE:** *JIS B4 can be fed either long edge or short edge first.*

## Paper width and throughput speed (LCDS printing only)

The width of the paper you use for your LCDS print job is directly related to the rate at which the printer can print the job. The rate at which a job prints is called the “throughput speed” and is measured in pages per minute (ppm).



**NOTE:** *“Pages per minute” actually means “impressions per minute,” referring to one side of a printed sheet.*

A pitch is the amount of time the printer takes to image a page on the photoreceptor belt. The term “pitch mode” refers to the number of pitches that can occur during one complete photoreceptor revolution. The pitch mode in which a specific job prints is based on the paper size used for that job.

The following table lists the pitch mode boundary values, paper widths, and related printing speeds for the system. The chart

shows that the shorter the paper width, the higher the pitch mode and the faster the throughput speed (higher page per minute rate).

**Table 1-5 Throughput data for DP100**

Pitch	Paper width	Speed
5	7 to 12.12 in / 178 to 308 mm	100 ppm
4	12.12 to 15.31 in / 308 to 389 mm	77 ppm
3	15.31 to 17 in / 389 to 432 mm	58 ppm

**Table 1-6 Throughput data for DP115**

Pitch	Paper width	Speed
6	7 to 10.19 in / 178 to 259 mm	116 ppm
5	10.19 to 12.12 in / 259 to 308 mm	96 ppm
4	12.12 to 15.31 in / 308 to 389 mm	77 ppm
3	15.31 to 17 in / 389 to 432 mm	58 ppm

**Table 1-7 Throughput data for 135**

Pitch	Paper width	Speed
8	7 to 7.4 in / 178 to 188 mm	154 ppm
7	7.4 to 9.01 in / 188 to 229 mm	135 ppm
6	9.01 to 10.19 in / 229 to 259 mm	116 ppm
5	10.19 to 12.12 in / 259 to 308 mm	96 ppm
4	12.12 to 15.31 in / 308 to 389 mm	77 ppm
3	15.31 to 17 in / 389 to 432 mm	58 ppm

**Table 1-8 Throughput data for 155**

Pitch	Paper width	Speed
6	7 to 10.19 in / 178 to 259 mm	154 ppm
5	10.19 to 12.12 in / 259 to 308 mm	128 ppm
4	12.12 to 15.31 in / 308 to 389 mm	103 ppm
3	15.31 to 17 in / 389 to 432 mm	77 ppm



**Table 1-9 Throughput data for DP180**

Pitch	Paper width	Speed
8	7 to 7.4 in / 178 to 188 mm	206 ppm
7	7.4 to 9.01 in / 188 to 229 mm	180 ppm
6	9.01 to 10.19 in / 229 to 259 mm	154 ppm
5	10.19 to 12.12 in / 259 to 308 mm	128 ppm
4	12.12 to 15.31 in / 308 to 389 mm	103 ppm
3	15.31 to 17 in / 389 to 432 mm	77 ppm

Each time a job requires a different paper size that changes across a pitch boundary, the system performs a time-consuming xerographic quality adjustment. When the printing speed of an LCDS job appears to degrade due to the use of mixed stock sizes, the following actions may improve the performance:

- You can optimize throughput by double clicking on a job in Job Manager or double clicking on a queue in Queue Manager and selecting Properties. The Output tab has a Mixed Stock Size Job window where you can select Optimize throughput. You must also enter the width of the widest paper in inches or millimeters for the job.
- The job programmer may be able to improve the speed by using the LCDS PDL command OUTPUT TMODE in the JSL to run the print job in a lower pitch *mode*. Refer to the *OUTPUT TMODE parameter in the Xerox Document Services Platform Using LCDS Print Description Language* for information on using this command.
- Similarly, if the system cycles down frequently because your external finishing equipment has a slower throughput rate than the printing system, the OUTPUT TMODE command can be used to lower the pitch mode to match the speed of the finishing equipment. This can improve overall throughput by avoiding time-consuming cycle downs.



**NOTE:** *Pitch mode changes are supported only for LCDS printing.*

## Paper size and pitch mode minimum and maximum

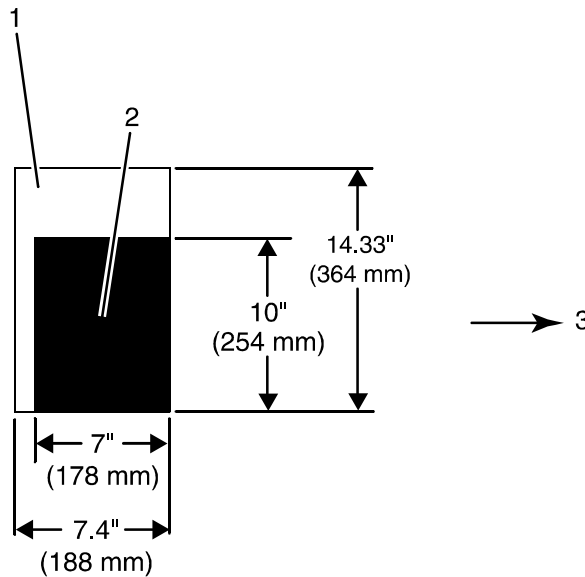
The illustrations in this section show the pitch modes in which you can operate, with the smallest and largest size papers supported by the printing system.

**Using small paper sizes in 8 pitch mode**

Printing in 8 pitch mode provides the highest throughput speed available (up to 206 ppm). However, keep the following in mind when you select the paper you want to use for this mode:

- Paper sizes smaller than 8 inches / 203 mm in width are supported only when the optional 7 inch paper kit is installed on the printer.
- The leading edge of any paper used in the printer cannot be less than 10 inches / 254 mm long.

The following figure illustrates the maximum and minimum paper sizes supported in 8 pitch mode.



**Figure 1-24 8 pitch mode paper sizes**

1. Maximum paper size for 8 pitch mode
2. Minimum paper size for 8 pitch mode
3. Travel direction of sheets out of paper tray

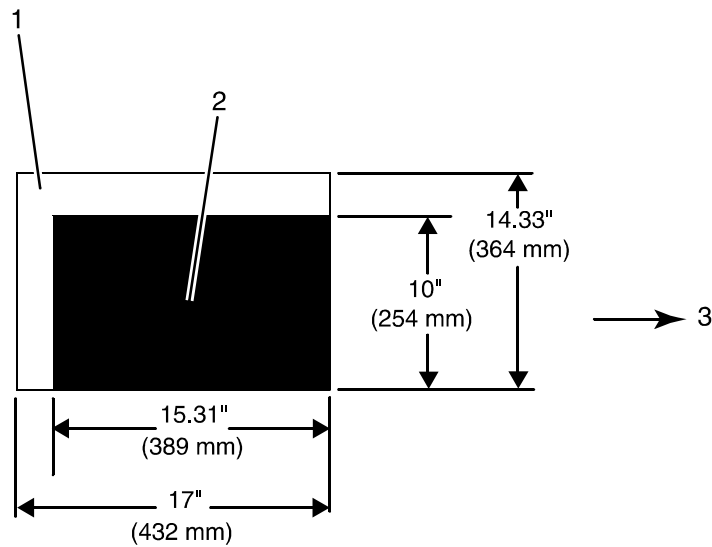
**Using large paper sizes in 3 pitch mode**

Large paper sizes with widths of 15.31 to 17 inches / 389 to 432 mm are supported only in 3 pitch mode and must feed short edge first. These paper sizes slow down the throughput speed. Therefore, a short edge feed job takes longer to print than a long edge feed job.



**NOTE:** The system can support 14 by 17 inch / 356 by 432 mm, 20 pound or 80 gsm paper stock in 3 pitch mode. However, printing performance is not guaranteed for all types of paper of this size. Heavy (110 pound / 200 gsm) and light (16 pound / 60 gsm) weight papers can cause jams throughout the system, and are not recommended.

The following figure illustrates the maximum and minimum paper sizes supported in 3 pitch mode.



**Figure 1-25 3 pitch mode paper sizes**

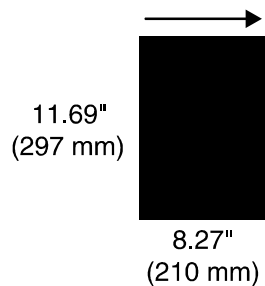
1. Maximum paper size for 3 pitch mode
2. Minimum paper size for 3 pitch mode
3. Travel direction of sheets out of paper tray

## Feed direction for standard paper sizes

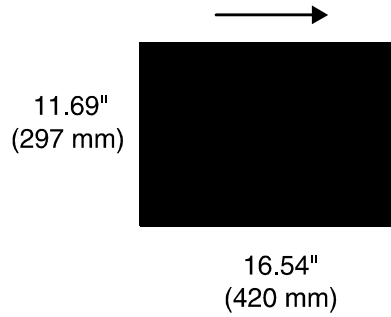
Currently, 14.33 inches / 364 mm is the maximum paper length for which the system supports long edge feeding (5 to 8 pitch mode). Any papers with long edges greater than this (such as 11 by 17 inch / 279 by 432 mm paper) must be loaded for short edge feeding (3 or 4 pitch mode).

The following figures show how some of the standard paper sizes feed through the printer in various pitch modes.

### European papers

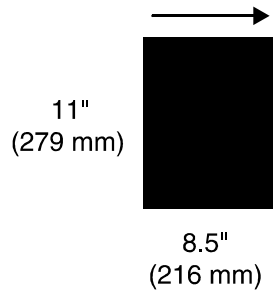


**Figure 1-26 A4 (210 by 297 mm) paper feeding (long edge feed)**

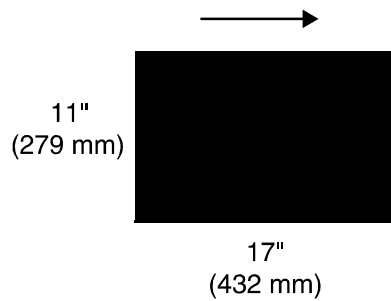


**Figure 1-27 A3 (297 by 420 mm) paper feeding (short edge feed)**

**US papers**



**Figure 1-28 US Letter (8.5 by 11 inch) paper feeding (long edge feed)**



**Figure 1-29 US Ledger or US Tabloid (11 by 17 inch) paper feeding (short edge feed)**

**B4 papers**

There are two versions of B4 paper: European (ISO B4: 9.84 by 13.89 inches / 250 by 353 mm) and Japanese (JIS B4: 14.33 by 10.12 inches / 364 by 257 mm). European B4 feeds long edge first, while JIS B4 may feed either long edge or short edge first.

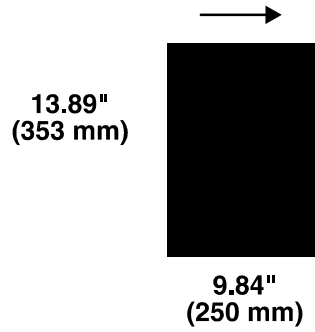


Figure 1-30 B4 (250 by 353 mm) paper feeding (long edge feed)

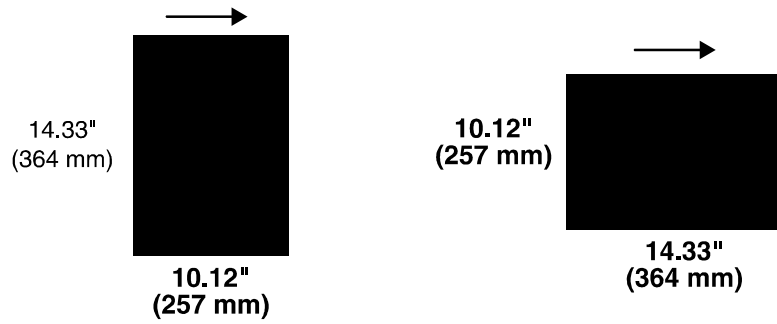


Figure 1-31 JIS B4 (257 by 364 mm) paper feeding (may be long or short edge feed)



## 2 Managing the printer

This chapter describes the operator tasks that are related to printing and print quality.

### Controlling the printer

---

You can perform the following tasks on the DocuSP Print Services window.

You can also select them from the Options pull-down menu on the Printer Manager window.



**NOTE:** *Where available, the printer control console enables you to control certain functions of the printer, such as stopping printing and continuing an interrupted job, without returning to the controller.*

### Interrupting printing

---

Click the red **[Pause Printing]** icon.

### Resuming printing

---

Click the green **[Resume Printing]** icon.

### Powering on the printer

---

Select **[Printer On]** from the Printer menu.

### Powering off the printer

---

1. Select **[Printer Off]** from the Printer menu.
2. Click **[Yes]** on the confirmation window.

---

## Powering off the printer immediately

---

1. Select [**Immediate Printer Off**] from the Printer menu.
2. Click [**Yes**] on the confirmation window.

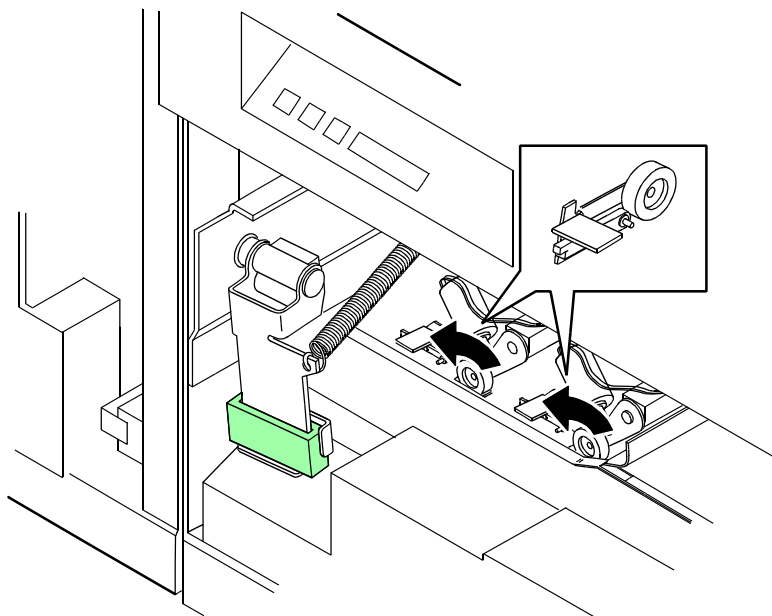
---

## Adjusting the registration transport roll levers for heavy paper

---

When you use paper that is heavier than 24 pounds/90 gsm, you must adjust the registration transport roll levers, which are located behind areas 2 and 4.

1. Open the right and left doors of the printer.
2. For each lever:
  - a. Pull the lever toward you.
  - b. While holding the lever toward you, turn it to the left.

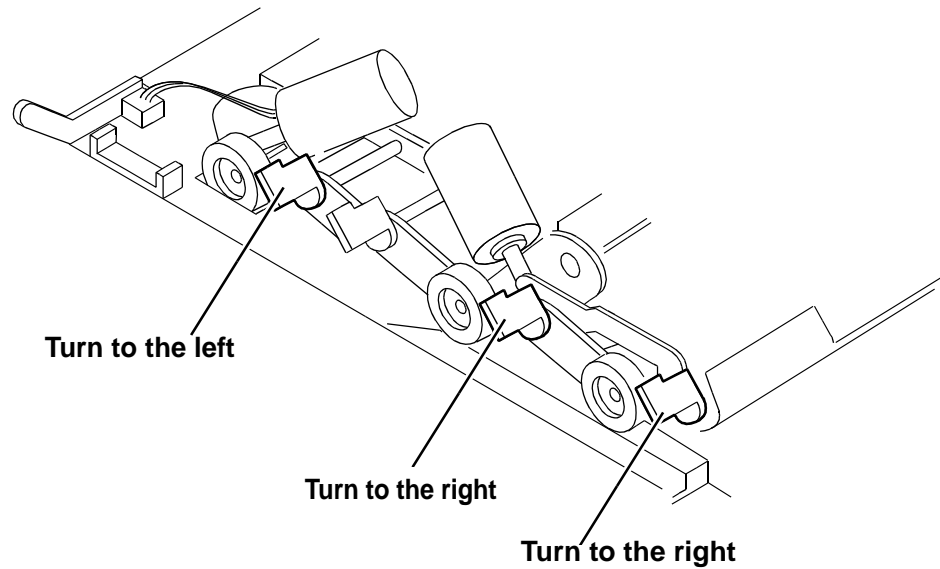


**Figure 2-1** Turning the registration transport roll levers

**For systems with small paper (7 by 10-inch/178 by 254 mm) enablement:**

Systems with this option have three levers. To process heavy papers, turn the levers as shown in the following figure.





**Figure 2-2 Three levers in systems with small paper enablement**



**NOTE:** Use the same pressure setting for all levers.

When the job is complete, return the levers to their normal positions.



**NOTE:** Positioning may be affected by machine tolerance, the paper supplier, or job type (for example, duplex).

## Loading paper

Your printer may have up to six feeder trays: two processor trays (trays 1 and 2) and two to four high-capacity trays (trays 3 through 6). Up to six different stocks may be used within a print job, including oversized cover stock or tabs.

- You can unlock, pull out, and load any tray from which paper is not being fed, without interrupting printing.
  - If you open a tray that is in use, feeding switches to a backup tray. If no tray is available, printing stops.
  - The printer stops feeding paper from any tray when a ¼-inch/6 mm stack remains in the tray.
1. Unlock the tray that you want to load, using one of the following methods:
    - **On the printer:** Press the Tray Unlock button on the front of the tray.

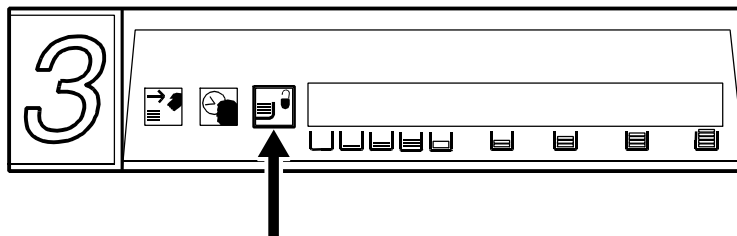


Figure 2-3 Tray Unlock button on feeder

- **At the display monitor:** On the Printer Manager window, Paper Trays tab, right click the tray name. From the properties pop-up menu, select [Tray Unlock].



**NOTE:** If the printer stops due to insufficient paper in a tray, the system unlocks the tray.

2. When the green Ready to Open indicator lights, pull the feeder tray out until it stops.

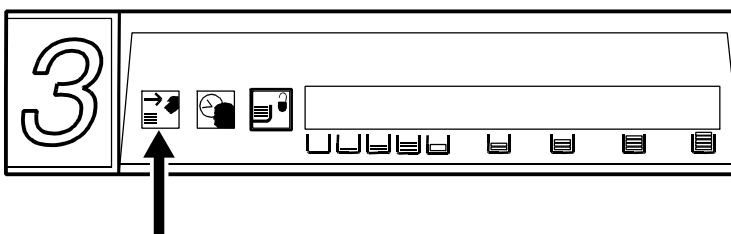


Figure 2-4 Ready to Open indicator

3. Place the paper in the tray, following the instructions on the labels.

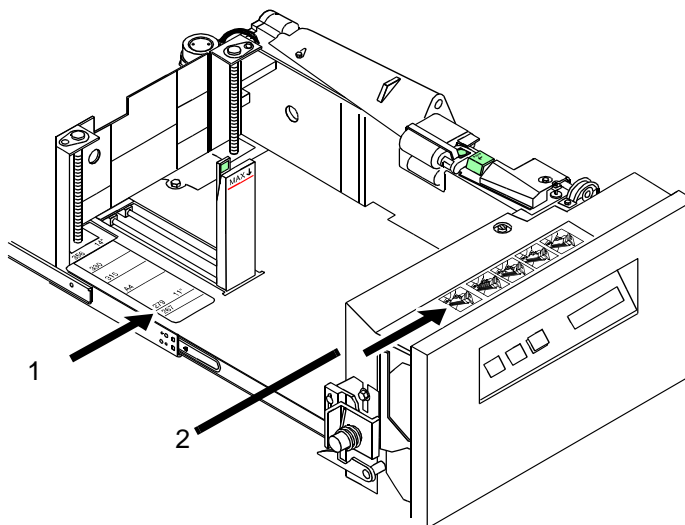


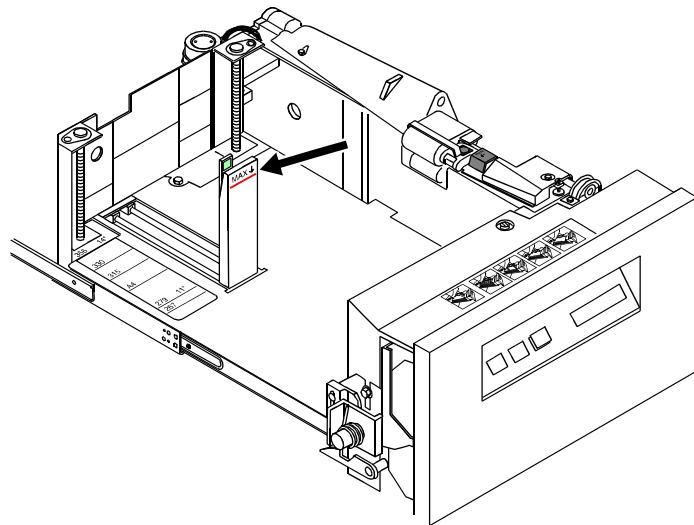
Figure 2-5 Tray labels

1. Paper edge guide lines
2. Loading instructions

Do the following:

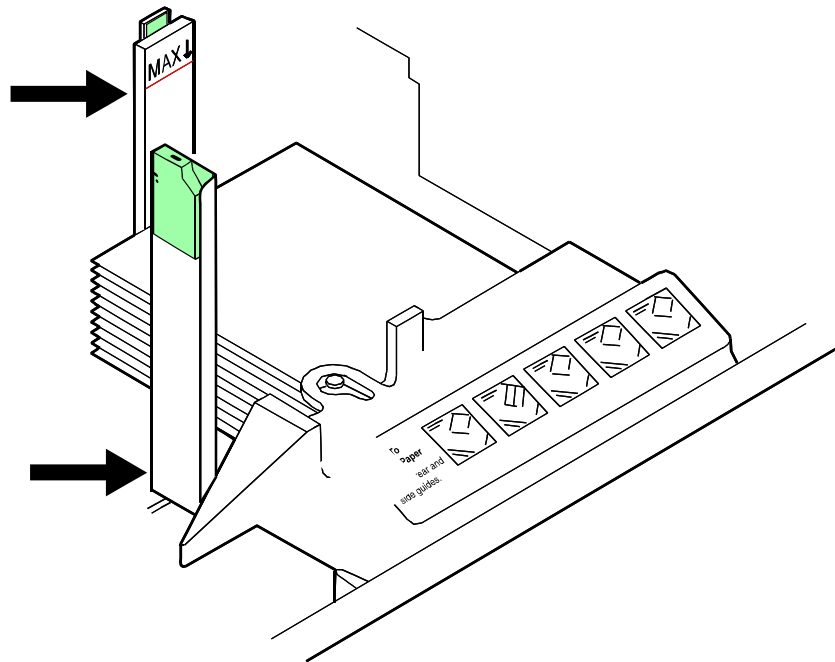
- Remove any damaged sheets.
- Trays 1 and 2: Load paper with the wrapper seam side **up**.
- Trays 3, 4, 5 and 6: Load paper with the curl side up. If you do not see any curl, load the paper with the wrapper seam side **down**.
- Fan predrilled paper fan thoroughly and remove any paper plugs.
- Load transparencies and 9-inch / 229 mm tabs into trays 1 and 2 only.
- Ensure that the paper is loaded into the right front corner of the tray.

**CAUTION:** *Do not load above the MAX line on the paper guide.*



**Figure 2-6 Maximum fill line**

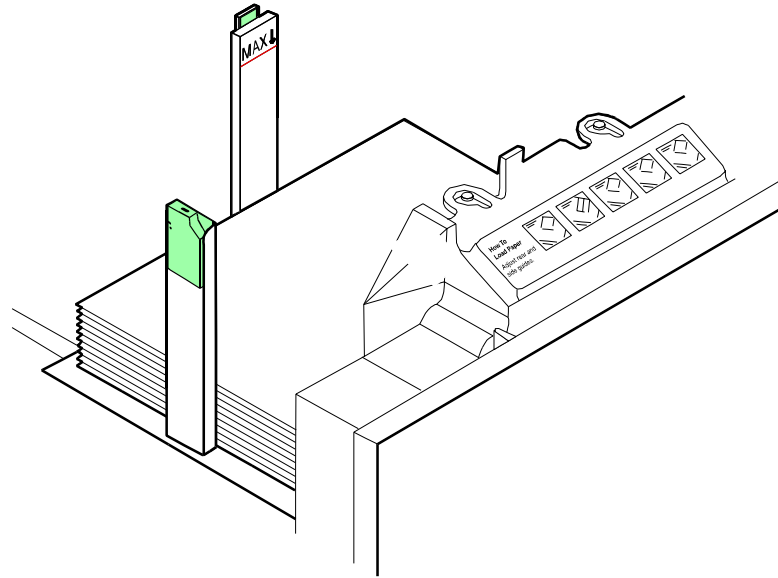
- After loading paper in tray 1 or 2, adjust the rear guide to touch the paper stack.
- In tray 3, 4, 5, or 6, adjust the rear and side paper guides to touch the stack.



**Figure 2-7 Rear and side guides in trays 3, 4, 5, and 6**

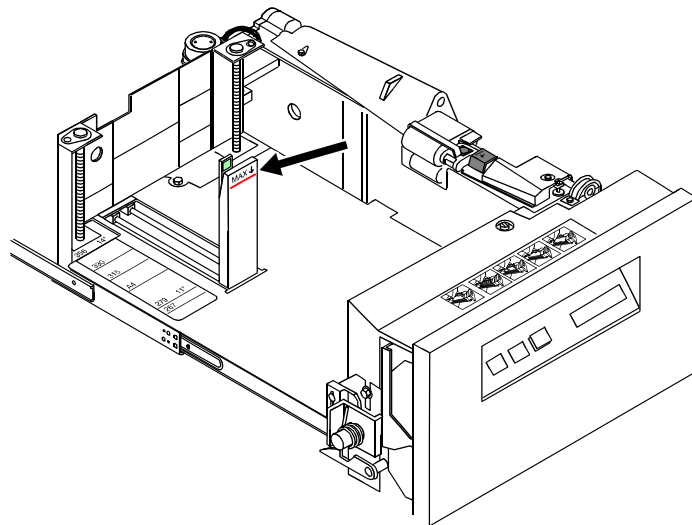


**NOTE:** To enable short-edge feed (SEF) for larger papers, load paper with the short edge against the side paper guide and the long edge against the rear guide.



**Figure 2-8** Large paper loaded for short edge feeding; for example, 11 by 17 inches / 279 by 432 mm

3. In trays 1 and 2, slide the rear guide until it touches the stack.



**Figure 2-9** Slide rear guide to stack

4. Press the green dot on the tray latch until the assembly clicks into place.

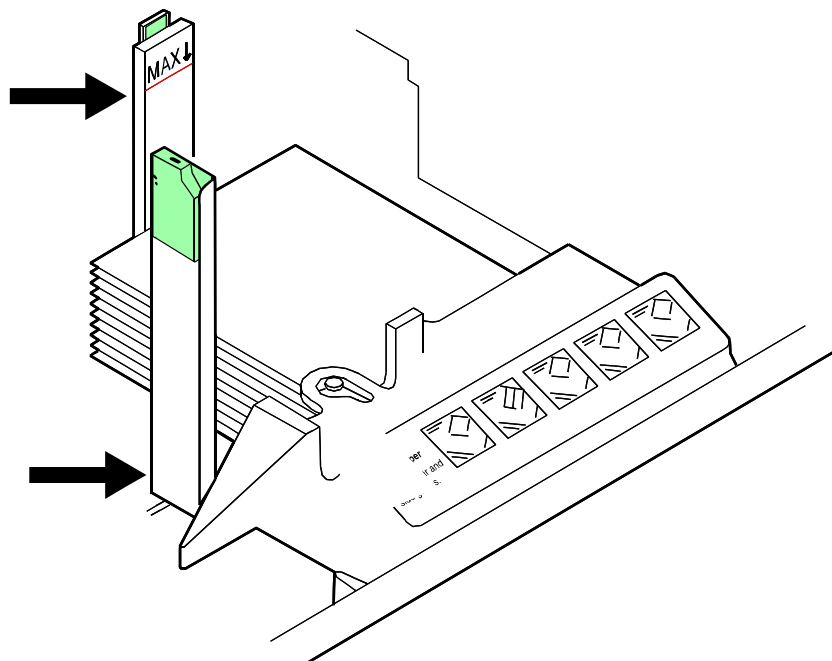


Figure 2-10 Press green dot on tray latch

5. Push the tray in slowly but firmly, until it latches.



**CAUTION:** *Do not slam the tray closed.*

6. If the printer has stopped due to low paper, select Continue on the display monitor.

## Unloading a stacker bin

---

Follow this procedure to unload printed output from a stacker bin.

1. Select a bin for unloading by pressing the Bin Unload button on the bin control panel. You can also select a bin for unloading from the printer mimic on the printer control screen.

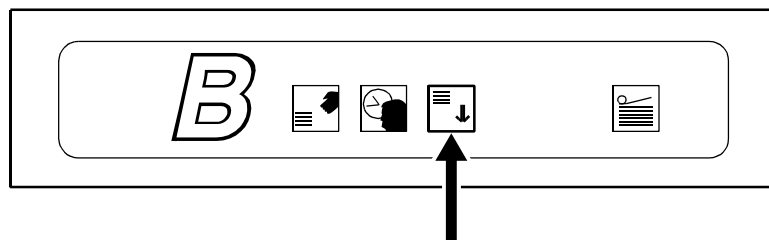


Figure 2-11 When a bin is selected, the bin elevator lowers.



**NOTE:** After the bin elevator lowers, the bin cannot be used until it is emptied completely.

- When the bin elevator stops in the down position, the Ready to Unload indicator lights.

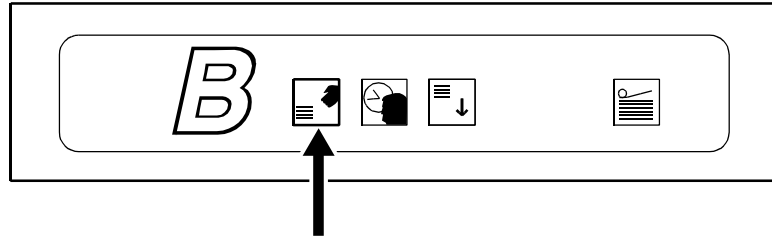


Figure 2-12 Ready to Unload light



**CAUTION:** Always use both hands to lift a container or pallet out of the bin.

- Open the bin doors, pull the platform out until it stops, and lift the container, pallet (for “pallet only” stacking), or paper stack off the platform.

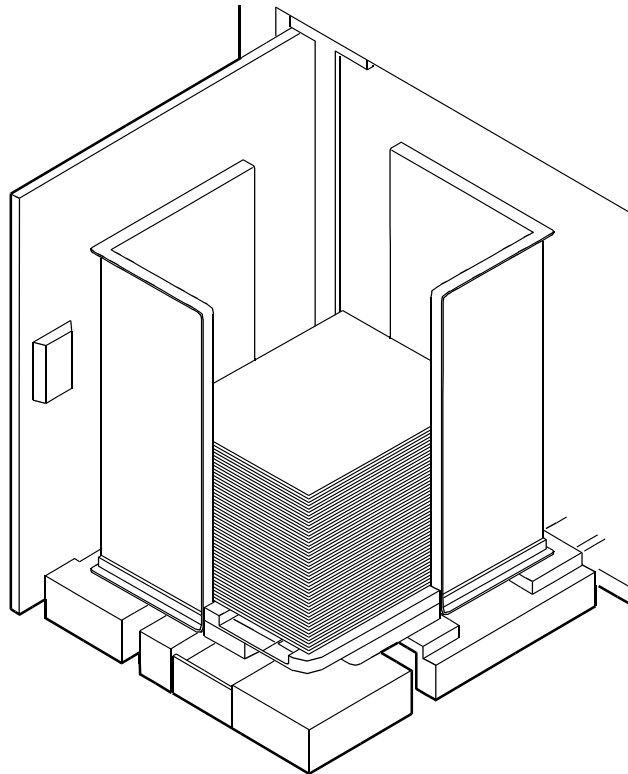


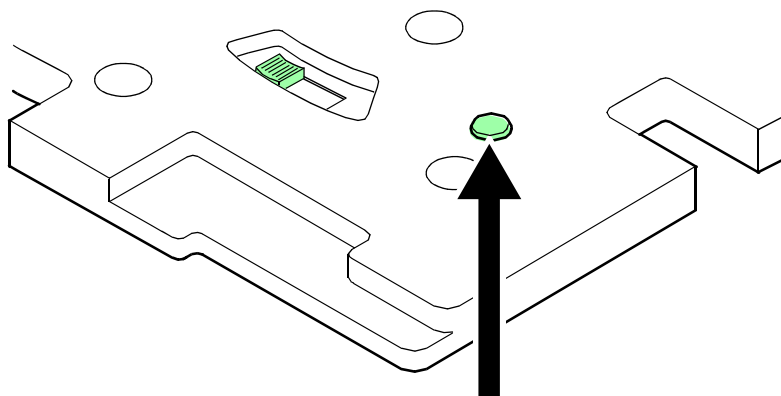
Figure 2-13 Lift container, pallet, or paper stack

- Carry the loaded container, pallet, or paper stack to a nearby table or paper cart.

5. If you are using a container or pallet, empty it and return it to the stacker bin.

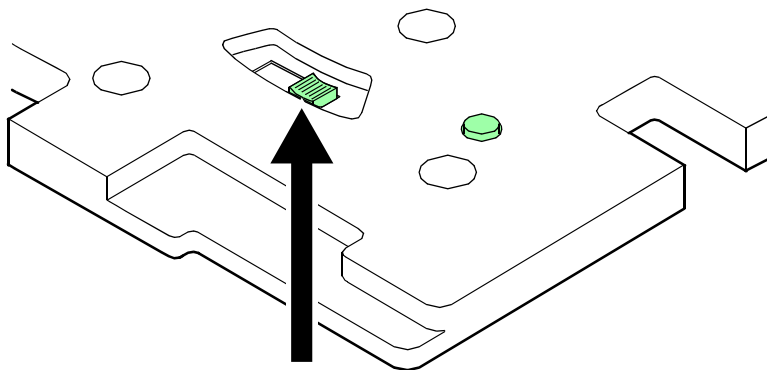
**Points to note for containers:**

- The empty container must be the same size as the previous container if the bin is in an auto switching combination, or if the print job is not complete and stacking continues into the bin.
- A different size container may be used if the bin is not selected for use or is not in an auto switching combination.
- To switch from containerless stacking to stacking in a container or on a pallet (for “pallet only” stacking), press and release the green button on top of the stacker bin platform.



**Figure 2-14 Press and release green button**

- To switch from stacking into a container or pallet to containerless stacking, slide the green tab (located on top of the stacker bin platform) forward until you hear a click. The following figure shows the green tab location.



**Figure 2-15 Slide green tab forward**



6. Firmly push the platform back to its original position and close the bin doors. The bin elevator rises, and the bin is again ready for use.



**NOTE:** *The platform does not rise until you have opened and closed both bin doors.*

*If the bin is not empty, the elevator remains down, and a message appears on the display monitor telling you to empty the bin.*



# 3 Managing the system

This chapter provides management-related information that pertains to the system as a whole such as starting, stopping, and rebooting the system and operating the tape drives.

## Starting, stopping, and rebooting the system

---

Shut down and reboot the system only when you are directed in the “Troubleshooting” chapter of this guide; or after loading new software, such as Novell NetWare or AppleTalk gateways.



**CAUTION:** *Do not shut down the controller using the Quit option on the pull-down menu of any window or the Exit option on the Workspace pop-up menu.*

## Powering on the controller

---

Wait at least one minute after power has been switched off before continuing. Then switch on power to the controller components in the following order:

1. Any external SCSI devices, starting with the unit with the SCSI terminator and following the connection chain toward the Sun workstation
2. Other peripherals
3. Monitor
4. Sun workstation

When the operating system finishes rebooting, the Xerox application software starts. When the DocuSP Print Services window displays, power on the printer.

## Powering on the printer

---

1. Make sure the printer power cord is securely plugged into the power receptacle, and the power button is pressed on.
2. Log on as the Administrator or Operator.
3. On the DocuSP Print Services window, select [Printer On] from the Printer menu.

## Holding queues

---

Before rebooting or powering off the system, hold all active queues. A held queue does not release any jobs for printing, nor accept any jobs that are sent to it.

On the Queue Manager window, do the following for each active queue:

1. Right click the queue name.
2. From the Properties menu, select **[Do Not Accept Jobs]** or **[Do Not Release Jobs]**, as appropriate.

To hold all queues:

1. Right click in the queue list section, and select **[Select All]** from the pop-up menu.
2. Right click again in the queue list section and select **[Do Not Accept Jobs]**.
3. Right click in the queue list section, and select **[Do Not Release Jobs]**.

## Releasing queues

---

After rebooting or powering on the system, release all held queues.

On the Queue Manager window, do the following for each active queue:

1. Right click the queue name.
2. From the pop-up menu, select **[Accept Jobs]** or **[Release Jobs]**, as appropriate.

To release all queues:

1. Right click in the queue list section, and select **[Select All]** from the pop-up window.
2. Right click again in the queue list section, and select **[Accept Jobs]**.
3. Right click in the queue list section, and select **[Release Jobs]**.

## Rebooting the system (warm boot)

---

1. On the DocuSP Print Services window, click the **[Queue Manager]** icon.
2. Hold all queues. (Refer to “Holding queues,” earlier in this chapter.)

3. On the DocuSP Print Services window, select [**Exit**] from the System menu. All GUI windows disappear.
4. Open a Terminal window, as follows:
  - a. Right click on the screen background.
  - b. From the Workspace pop-up menu, select [**Tools**].
  - c. From the Tools menu, select [**Terminal**].
5. In the Terminal window, log on as root user.
6. Enter:

```
sync; sync; reboot
```
7. When the DocuSP Print Service window reopens, log on as Operator or Administrator.
8. Power on the printer by selecting [Printer On] from the Printer menu.
9. Release all held queues. (Refer to “Releasing queues,” earlier in this chapter.)

## Performing a deferred shutdown and reboot

---

Use this procedure when the system requests a reboot during a recovery, and you want to wait for queued jobs to finish printing.

1. On the DocuSP Print Services window, log on as Administrator or Operator.
2. Hold any active queues. (Refer to “Holding queues,” earlier in this chapter.)
3. On the DocuSP Print Services window, select [**Shutdown**] from the System menu.
4. When the DocuSp Print Services window closes and an ok prompt appears at the bottom of the screen, enter `boot`.
5. When the DocuSP Print Services window reopens, release all held queues. (Refer to “Releasing queues,” earlier in this chapter.)

## Performing an immediate shutdown and reboot

---

Use this procedure when the system requests a reboot during a recovery without waiting for queued jobs to finish printing.

1. On the DocuSP Print Services window, log on as Administrator or Operator.
2. Hold any active queues. (Refer to “Holding queues,” earlier in this chapter.)
3. On the DocuSP Print Services window, select [**Immediate Shutdown**] from the System menu.

4. Click [**Yes**] on the confirmation window.
5. When the DocuSP Print Services window closes and an ok prompt appears at the bottom of the screen, enter **boot**.
6. When the DocuSP Print Services window reopens, release all held queues. (Refer to “Releasing queues,” earlier in this chapter.)

## Restarting the DocuSP software

---

1. On the DocuSP Print Services window, log on as Administrator or Operator.
2. Hold any active queues. (Refer to “Holding queues,” earlier in this chapter.)
3. On the DocuSP Print Services window, select [**Restart**] from the System menu.
4. Wait for the DocuSP Print Services window to close and reopen.
5. Release all held queues. (Refer to “Releasing queues,” earlier in this chapter.)

## Powering off the system

---

You may be required to power down the system under the following conditions:

- Work is being done on an attached printer.
- The Sun workstation is being moved.
- SCSI peripherals are being added or removed.
- A power outage is planned.
- The Sun workstation is receiving hardware maintenance.
- The DocuSP controller will not be in use for an extended period.

The Sun workstation should run continuously. Refer to the Sun hardware manuals for recommendations for when to power off the system.



**CAUTION:** *Do not shut down DVD players and SCSI tape drives unless you are powering off the entire system.*

1. Log on as Administrator or Operator.
2. Hold any active queues. (Refer to “Holding queues,” earlier in this chapter.)
3. Select [**Printer Off**] from the Printer menu.
4. Select [**Shutdown**] from the System menu.

5. Click [**Yes**] on the confirmation window.
6. When the DocuSP Print Services window closes and an ok prompt appears at the bottom of the screen, switch off power to the computer components in the following order:
  - a. Any external SCSI devices, such as disk drives, tape drives, or DVD players
  - b. Any other peripheral devices, such as modems
  - c. Sun workstation
  - d. Monitor
7. When the DocuSP software is running again, resubmit any documents that had not completed printing.

### Performing an emergency power off

Disconnect the power cable from the power outlet immediately after powering off, and contact your Xerox service representative. Use this procedure to switch off power quickly if any of the following occurs:

- The equipment emits unusual odors or makes unusual noises.
- The power cable is damaged or frayed.
- A wall panel circuit breaker, fuse, or other safety device is switched.
- Liquid is spilled into the equipment.
- The equipment is exposed to water damage or flooding.
- Any part of the equipment is damaged.

### Powering off the controller



**CAUTION:** *This procedure may corrupt the DocuSP software or result in data loss. Use it only in emergency.*

1. On the DocuSP Print Services window, select [**Immediate Shutdown**] from the System menu.
2. After the DocuSP Print Services window has closed, shut off the power to the controller by one of the following methods:
  - Switch off the controller power switch, located on the front of the processor.
  - Grasp the controller plug firmly and pull it from the wall outlet.



**Warning:** *Do not grasp the cable to pull out the plug.*

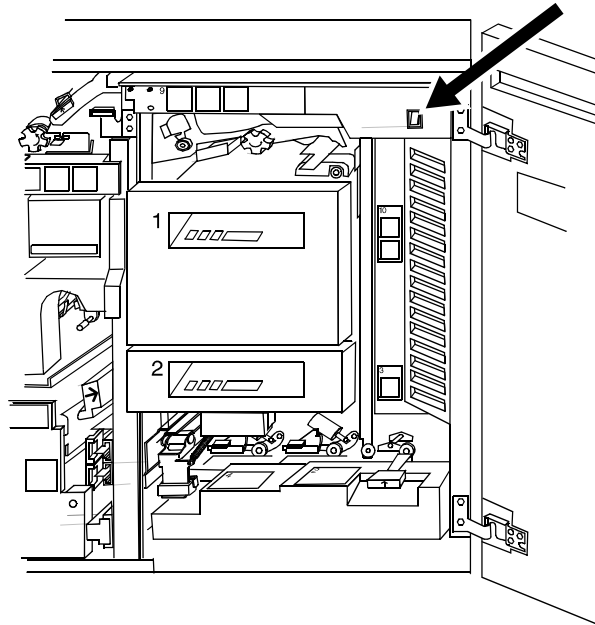
- Switch off the controller power strip.



**NOTE:** *This method powers off everything that is plugged into the power strip, including the processor, monitor, QIC tape drive, 36-track tape drive, and external hard disk drive.*

## Powering off the printer

1. Power off the controller.
2. Shut off power to the printer by one of the following methods:
  - Open the right front door of the printer and press the power button.



**Figure 3-1 Shutting off power**

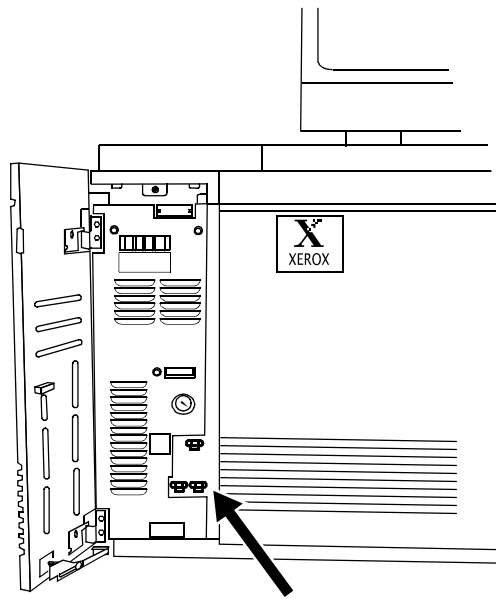
- (U. S. only) Grasp the printer plug firmly and pull it from the wall outlet.



**WARNING:** *Do not grasp the cable to pull out the plug.*

- Open the left door of the printer, and push down circuit breakers CB101, CB102, and CB103.





**Figure 3-2** Circuit breaker locations

## Operating the 18/36 track tape drive

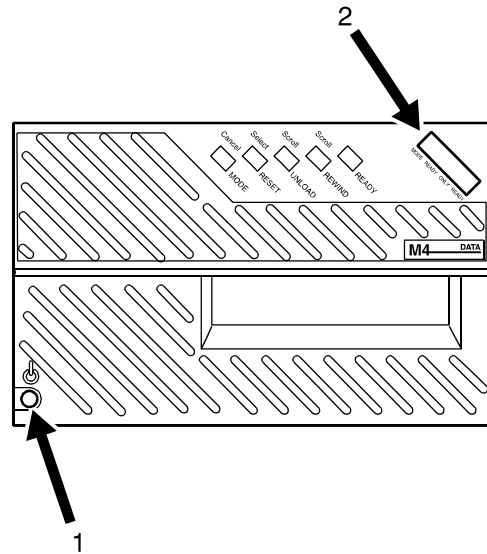
---

The external 18/36 track tape drive uses 1/2-inch cartridge tapes. You can use it to load resources and to submit offline print jobs.

### Powering on the tape drive

---

Press the Power button on the front of the drive.  
The drive displays the name of each diagnostic test while performing it.



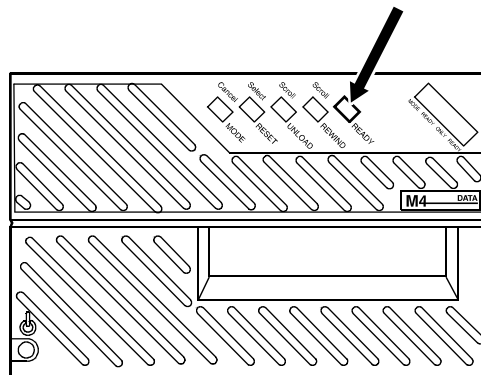
**Figure 3-3** Press the power button and display diagnostic test

1. Power switch
2. Message display

## Powering off the tape drive

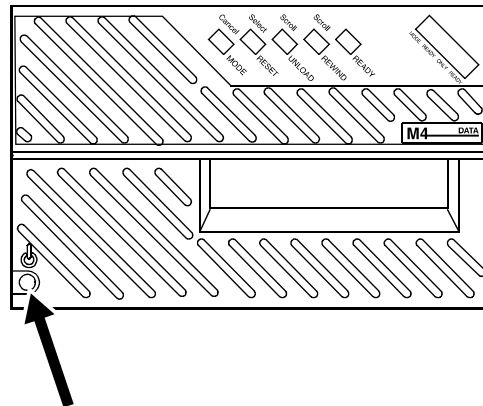
---

1. Press the Ready button.



**Figure 3-4** Ready button

2. Unload any tape cartridge.
3. Press the Power button.



**Figure 3-5 The Power button**

## Placing the tape drive online

1. Load a tape cartridge in the drive.
2. Press the Ready button.

If a tape is loaded but the drive is not online, press the Ready button to place the drive online.

## Loading a tape

Before loading a tape, check the cartridge for damage.



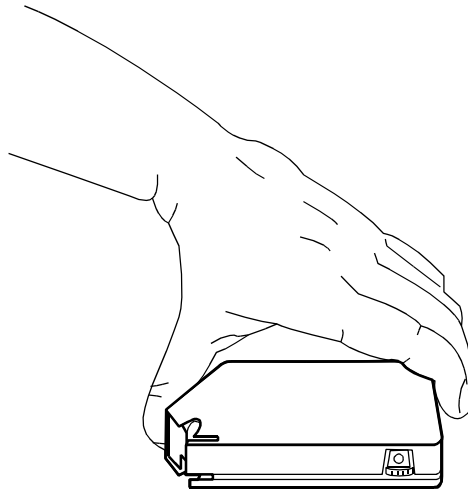
**CAUTION:** *A damaged cartridge can prevent the tape from threading correctly and can damage the tape drive.*

Do not load a cartridge if:

- The case is cracked or broken.
- The leader block (the blank section at the beginning of the tape) or its latch is broken.
- The file protect selector or sensor is damaged.
- The label is peeling.
- The case contains any liquid.
- The tape was wound completely out of the cartridge, then reattached to the cartridge reel.

If a cartridge is damaged, substitute one that contains a backup version of the data.

1. Hold the cartridge with the smooth side on top and the leader block toward the drive.

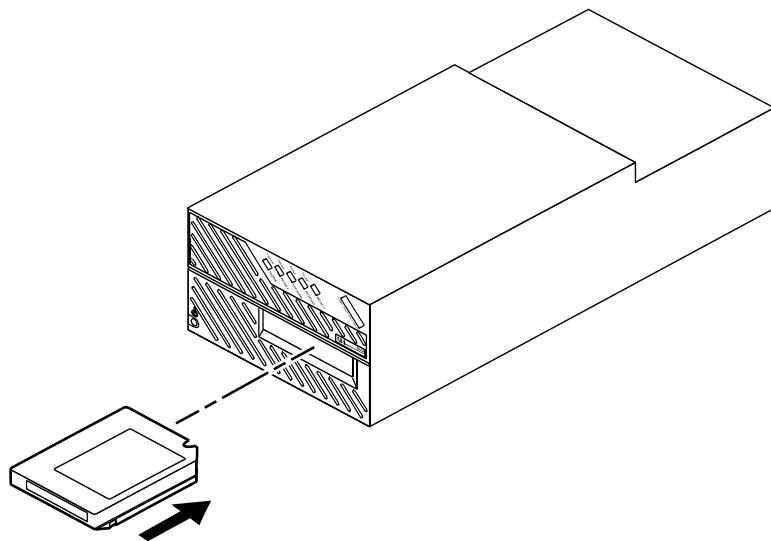


**Figure 3-6 Hold the cartridge**



**CAUTION:** *Never force a cartridge into the tape drive.*

2. Slide the cartridge into the entry slot of the tape drive until it stops.



**Figure 3-7 Slide cartridge into entry slot**

After about 15 seconds, the tape is loaded. The message window displays Online, and indicates whether the cartridge is file protected (F) or unprotected (U).

---

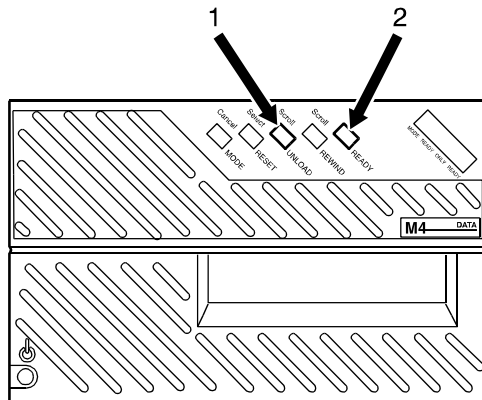
## Unloading a tape

### Automatic procedure

When a job is finished, the tape drive rewinds the tape and unloads and ejects the cartridge.

**Manual procedure**

1. Press the Ready button to take the tape drive offline.
2. Press the Unload button.



**Figure 3-8 The Unload and Ready buttons**

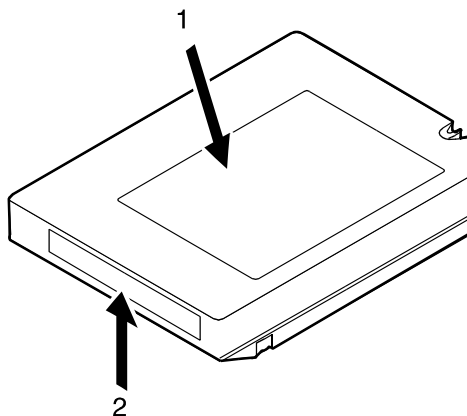
1. Unload button
2. Ready button

The message window indicates when the tape drive is rewinding or unloading.

## Guidelines for handling cartridges

- Never pry open the feed slot door of the tape drive.
- Never force a tape cartridge into or out of the tape drive.
- Never leave a cartridge in the tape drive while powering off. This could damage data on the tape and the tape drive components.
- Store cartridges vertically in a clean area that has the same temperature and humidity as the tape drive location.
- If the storage environment is different, bring the cartridges into the tape system environment 24 hours before using them.
- Never remove the protective wrapping until you are ready to use the cartridge.
- Every time you pick up a cartridge, ensure that the leader block is latched.
- Never carry two or more cartridges loose in a container. Leader blocks can snag on other cartridges and unlatch.
- Keep cartridges clean and dry.
- Never release a leader block and pull tape from a cartridge.
- Never open a cartridge.
- Never expose tape or a cartridge to direct sunlight.
- Never smoke near the tape drive or cartridge storage areas. Tobacco smoke and ash are damaging to tapes.

- Never place cartridges near electric motors or any other magnetic sources that may erase data.
- To clean a cartridge, wipe off dust, dirt, and moisture with a lint-free cloth.
- If you must use a cleaning solution, make sure it is formulated for tape cartridges. Never allow the solution to touch the tape.
- If a leader block comes off and there is no other damage, you can use a leader block repair kit to reattach the block. You can then use the cartridge one more time to copy the data onto a new cartridge.
- If a label starts to peel, replace it immediately.
- Do not write on a label that is on a cartridge. Write a new label, remove the old one, and replace it with the new one.
- Place the two labels in the recessed areas of the cartridge as shown below:



**Figure 3-9 Placement of labels**

- 1. Customer label on top**
- 2. Volume/serial number label opposite side of thumbwheel**

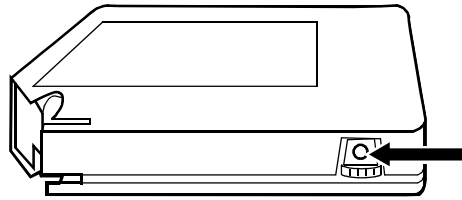
- Write on labels with markers that do not smear.
- Use only labels that leave no residue when removed.

## Setting file protection

---

To make a tape read-only, turn the thumbwheel on the side of the cartridge until a white dot appears in the window.

To enable writing to the tape, turn the thumbwheel until the dot is not visible.



**Figure 3-10** File protection dot

## Printing the online Help documentation

---

You can print out the entire set of Help documentation screens from the controller as a single document.

1. From the Help pull-down menu, select [**Print Help Documentation...**].
2. On the Print Help Documentation window, select from the Queue menu the queue to which you want to send the Help file to print.
3. Click [**OK**]. The printer prints out the entire set of Help windows.





# 4 Maintaining the system

This chapter provides information on paper care, on adding and replacing consumable supplies such as dry ink, and on cleaning the various areas of the system, including the tape drives.

## Paper care

---

Correct storage and handling of media prevents jams and delays, and ensures optimum productivity.

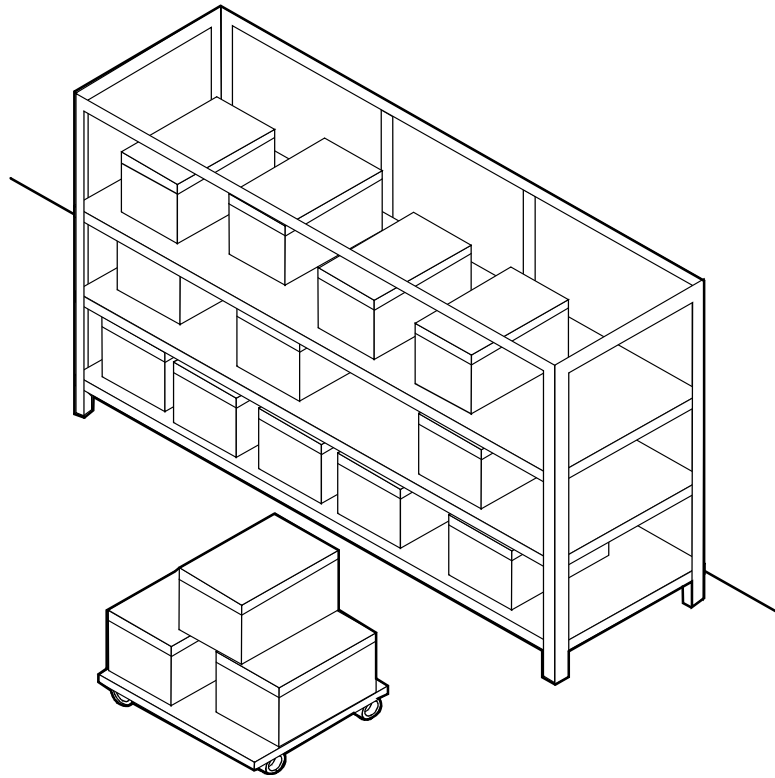
### Storing paper

---

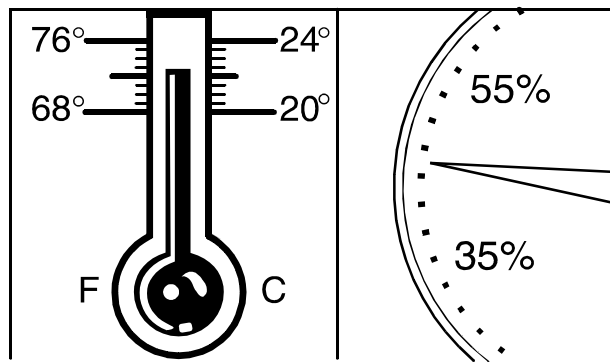
It is important to store paper correctly. Temperature and humidity affect the way your printer processes paper. Store paper in the cartons it came in. To reduce the possibility of moisture absorption, always place cartons on a wooden pallet or store them in a cabinet off the floor.

After removing the paper from its carton, always store it:

- In its wrapper
- On a flat surface
- In a closed cabinet
- In a cool, dry area
- In 68 to 76°F / 20 to 24.4°C
- In 35% to 55% humidity



**Figure 4-1 Storing paper correctly**



**Figure 4-2 Recommended temperature and humidity for paper storage**

## Conditioning paper

Because temperature and humidity affect paper performance in the printer, you need to condition paper before using it. To condition paper, store it for a specified length of time in the same type of environment as your printer.

The length of time you should condition your paper depends on the amount of paper and the difference between the storage and operating temperatures.

Use the following chart to determine the number of hours needed to condition stacked cartons of paper.



**NOTE:** *The numbers in the top two rows indicate the temperature difference between the storage area and the operating environment, not actual room temperatures.*

**Table 4-1** Temperature and hours needed to condition paper

Temperature difference between storage and operating areas							
	Fahrenheit						
	10°	15°	20°	25°	30°	40°	50°
	Centigrade						
	5.5°	8.5°	11°	13°	17°	22°	28°
Cartons	Hours needed to condition the paper						
1	4	8	11	14	17	24	34
5	5	9	12	15	18	25	35
10	8	14	18	22	27	38	51
20	11	16	23	28	35	48	67
40	14	19	26	32	38	54	75

**Example:** If you want to move ten cartons of paper from a storage area with a temperature of 90° F to an operating area with a temperature of 70° F (a 20° difference), you should do so at least 18 hours before using the paper.

## Paper curl

Before the manufacturer cuts paper into sheets, it is stored on large rolls. After it is cut and packaged, it retains some of the curl from the rollers.

Although it is unnecessary to load paper with the curl facing up or down, best results occur when you are consistent. For example, if you open paper with the wrapper seam up, always load it in the tray that way.

## Using consumables

The following tasks are part of maintaining your system:

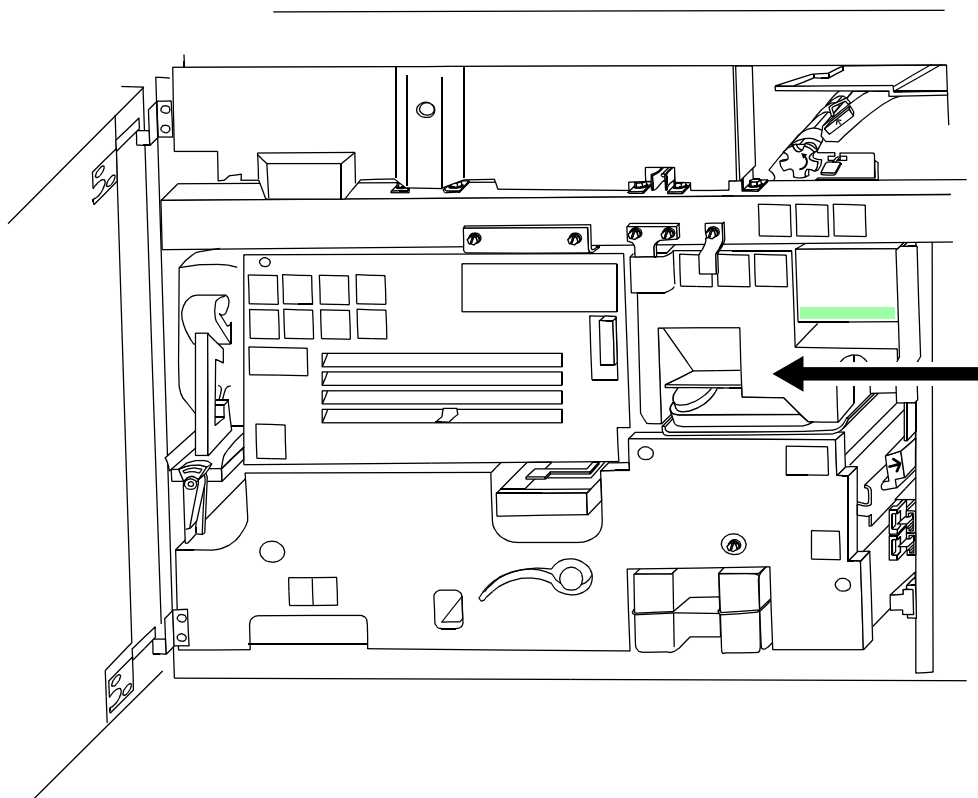
- Adding fuser agent
- Replacing the dry ink waste container
- Replacing the dry ink cartridge
- Using the custom transfer assist blade

### Adding fuser agent

**WARNING:** *Fuser agent contains silicone, which can cause irritation upon contact with the eyes. Be sure to wash your hands with soap and water after you finish this procedure.*

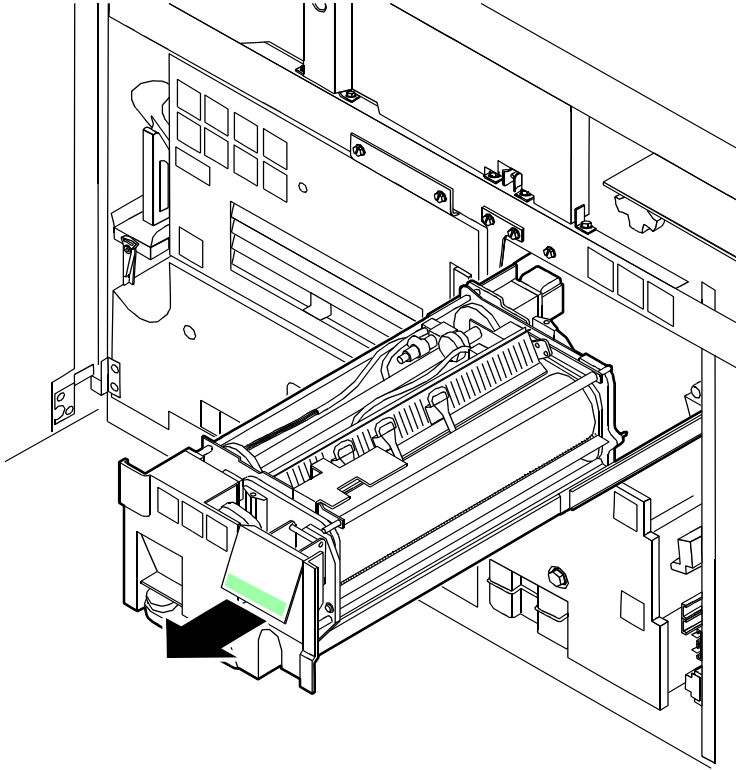
To add fuser agent:

1. Open the right and left doors of the printer and locate the fuser area.



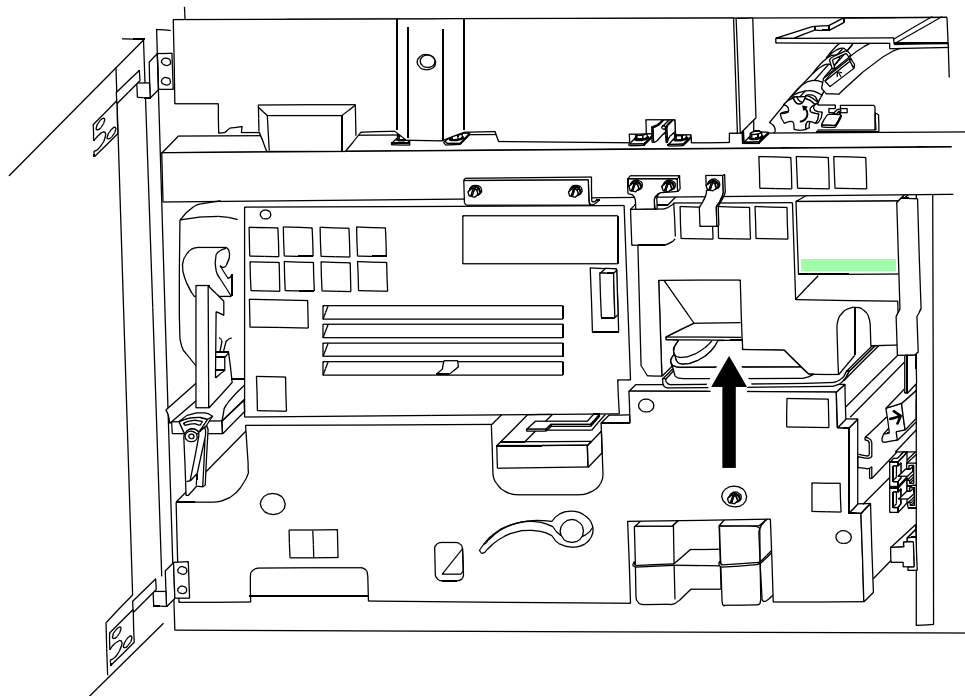
**Figure 4-3** The fuser area

2. Place a dropcloth on the floor under the fuser area.
3. Grasp the green handle on the fuser drawer and pull it out until it stops.



**Figure 4-4 Pull out fuser drawer**

4. Locate the fuser agent reservoir.



**Figure 4-5 The fuser agent reservoir**

5. Pull the fuser agent reservoir out until it stops.
6. Remove the reservoir cap by turning it counterclockwise.
7. Remove the cap from a new bottle of fuser agent.

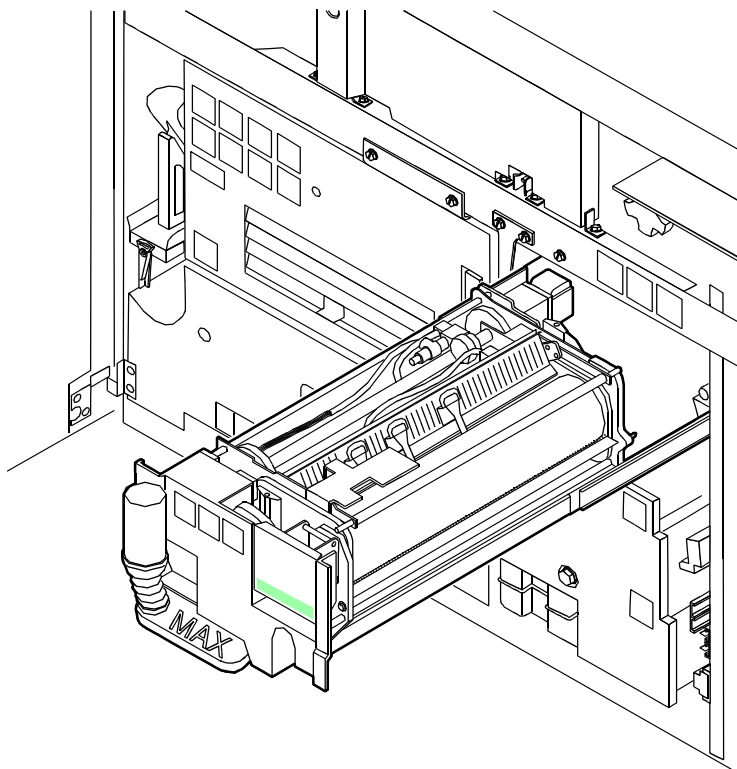


**WARNING:** *If any fuser agent spills on the floor, remove it immediately. Fuser agent spills make the floor slippery.*



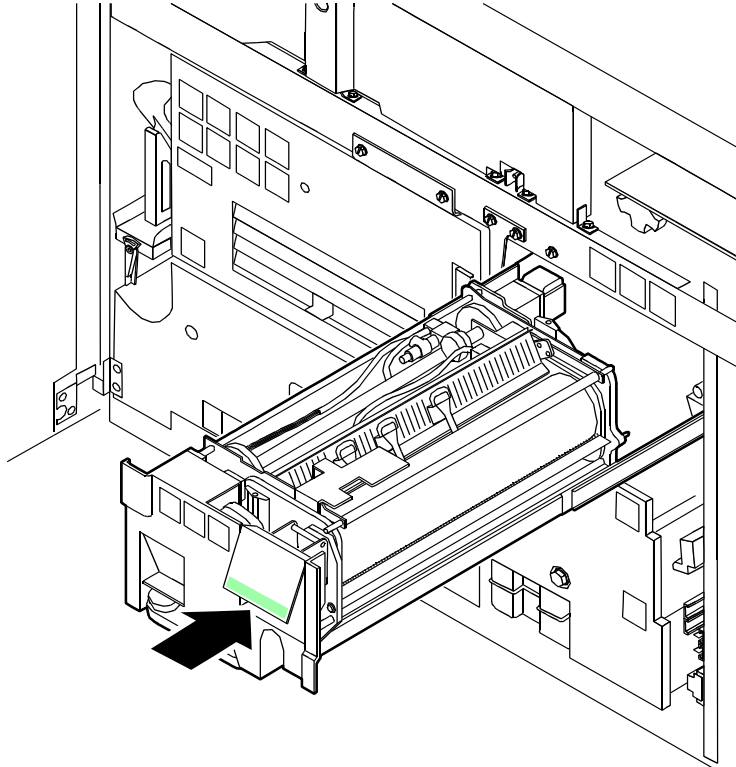
**CAUTION:** *The fuser reservoir has an antispash seal. Do not push the fuser agent bottle into the reservoir with excessive force, as this can damage the seal.*

8. Carefully pour the fuser agent into the reservoir, until the level reaches the MAX line.



**Figure 4-6 Pour fuser agent to MAX line**

9. Replace the reservoir cap by turning it clockwise.
10. Push the fuser agent reservoir in until it stops.
11. Push the fuser drawer in until it latches in place.



**Figure 4-7 Push in fuser drawer**

12. Close the printer doors.

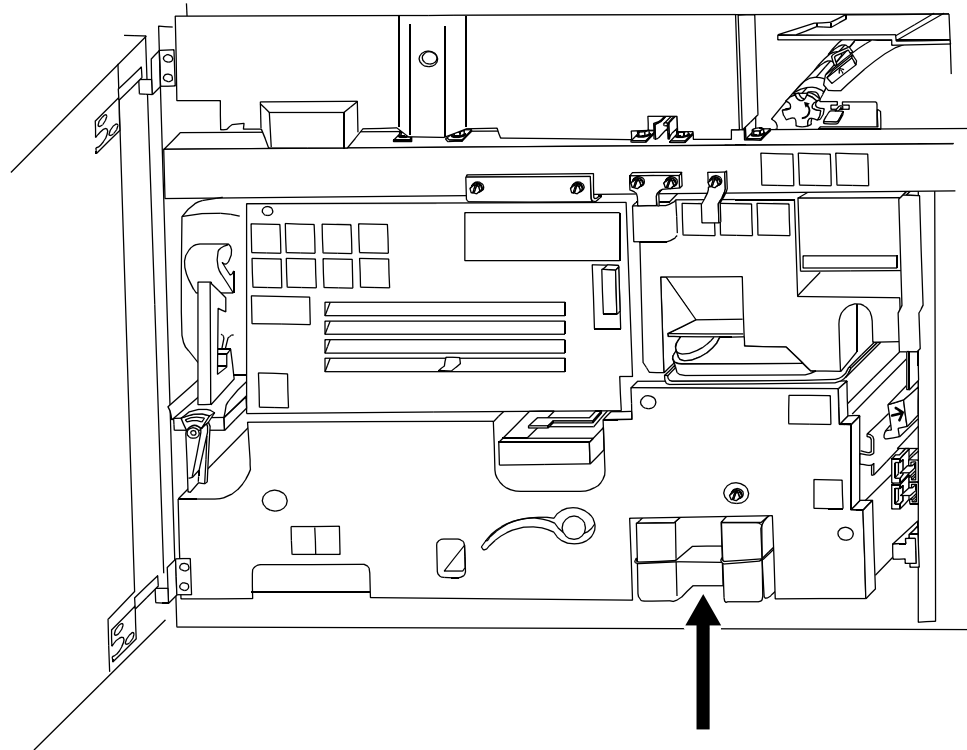


**NOTE:** *The fuser agent message disappears after the system prints between 32 and 40 sheets. Because the sheets must be processed continuously, you may want to run 45 test pages in order to clear the message from the system (unless the current print job contains at least 40 pages).*

## Replacing the dry ink waste container

To replace the dry ink waste container:

1. Open the right and left doors of the printer and locate the dry ink waste container.



**Figure 4-8 Dry ink waste container**

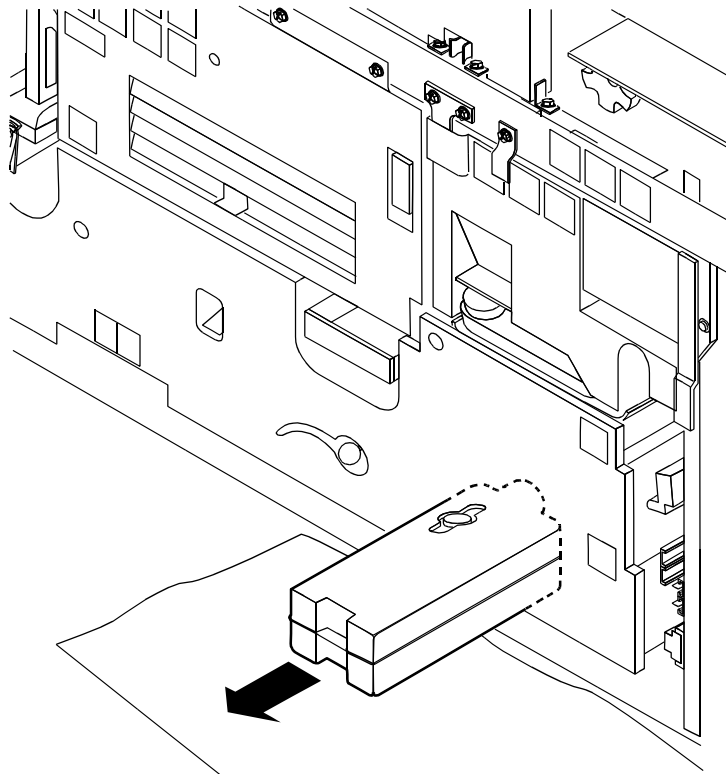
2. Place a dropcloth on the floor under the dry ink waste container area.



**CAUTION:** *To prevent dry ink spills, do not tip or tilt the waste container.*

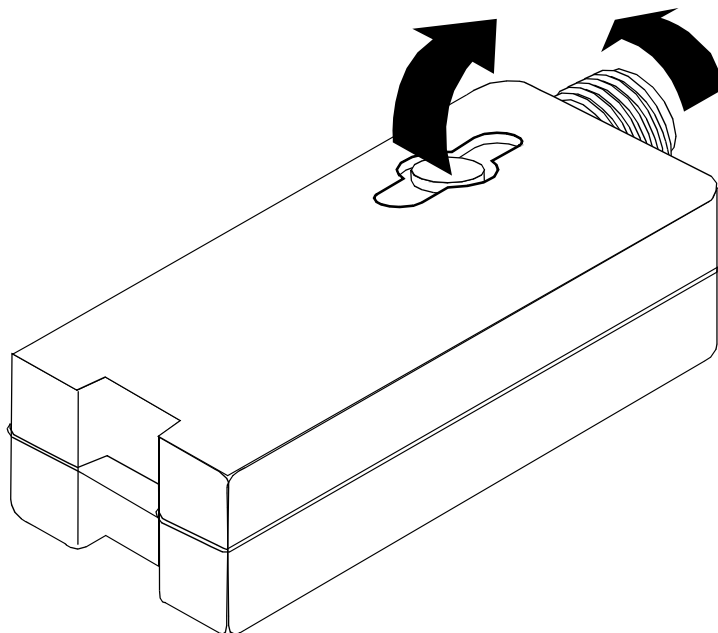
3. Pull the full waste container out of the printer.





**Figure 4-9 Pull out waste container**

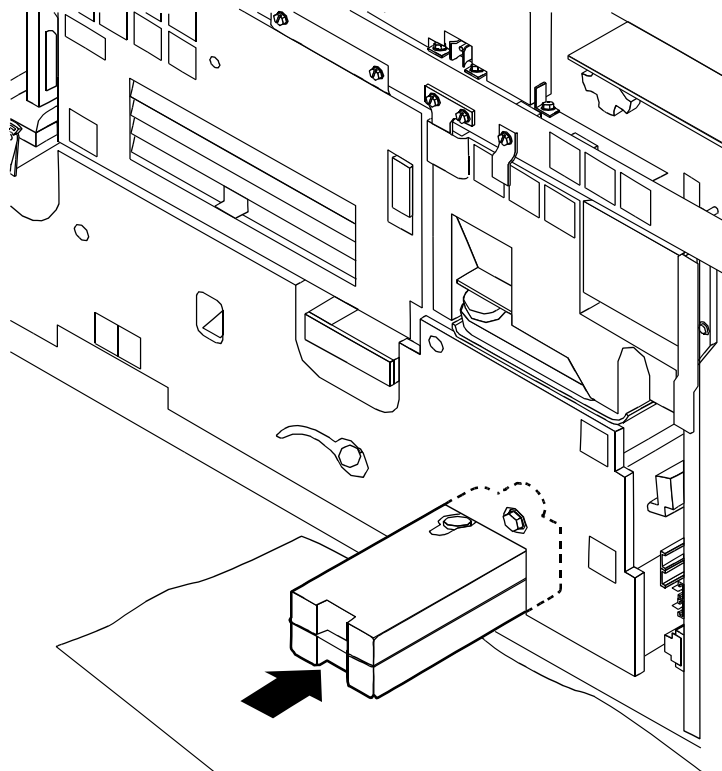
4. Remove the cap from the top of the full waste container.



**Figure 4-10 Remove cap**

5. Place the removed cap over the opening on the end of the full waste container.

6. Slide a new, empty, dry ink waste container into the printer until the container stops.



**Figure 4-11** Slide in new waste container

7. Close the printer doors.



**NOTE:** *If any dry ink gets on your hands, wash them with soap and cold water. Heat sets the ink permanently. If any dry ink gets on your clothes, brush them with a dry paper towel or a stiff bristled brush. If this does not remove the ink immediately, launder with detergent and cold water. Dry cleaners should be told that the spot is dry ink for a printer, so they do not use a solvent that sets the stain.*

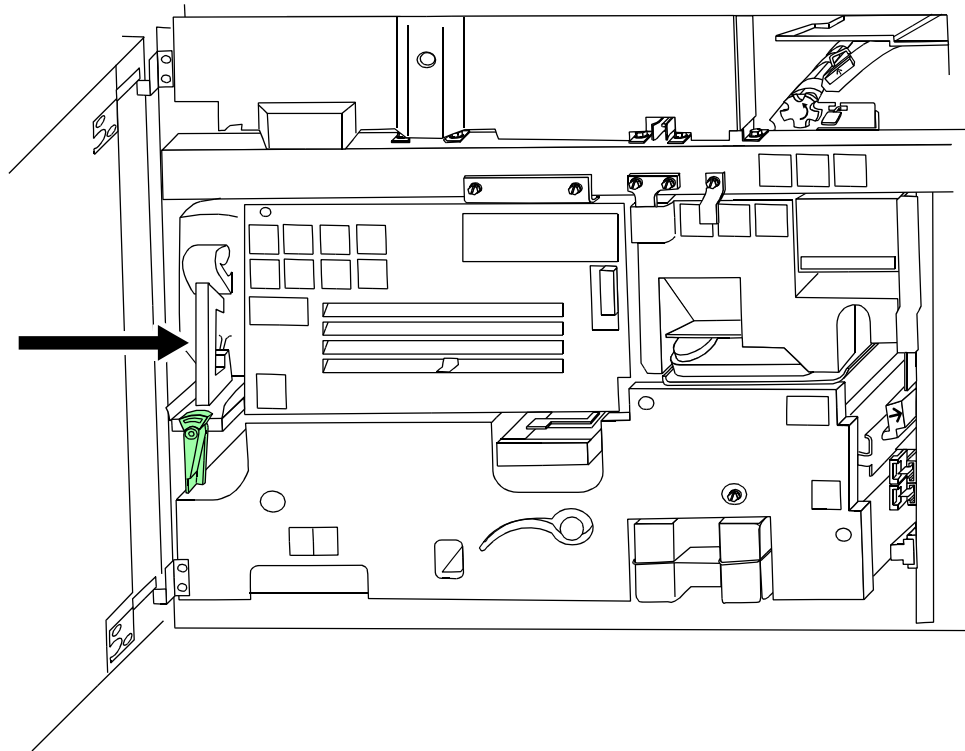
## Replacing the dry ink cartridge



**CAUTION:** To prevent dry ink spillage, remove the cartridge only when directed to do so by a message on the display monitor.

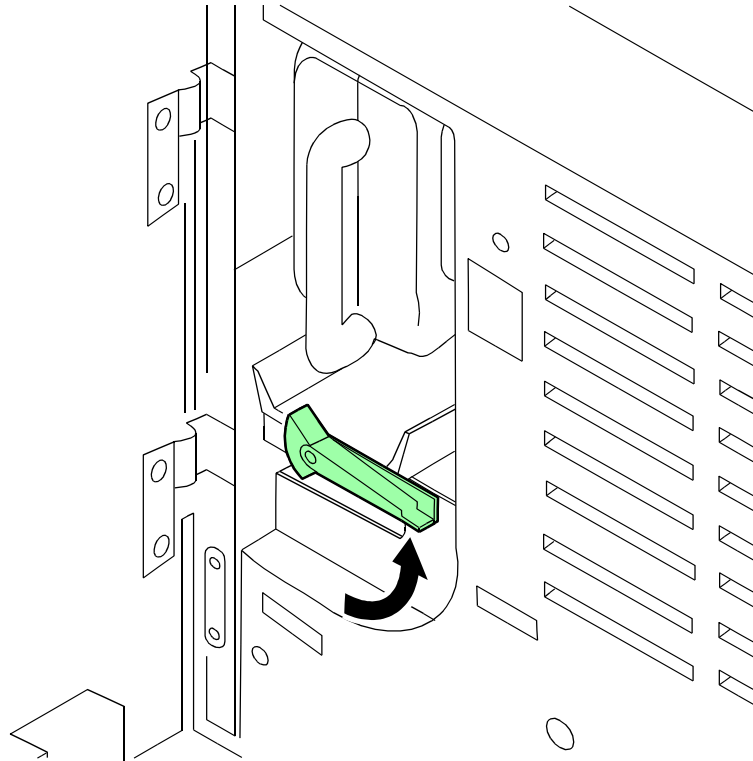
To replace the dry ink cartridge:

1. Open the right and left doors of the printer and locate the dry ink area at the left side of the printer. There are step by step instructions on the panel next to the dry ink cartridge.



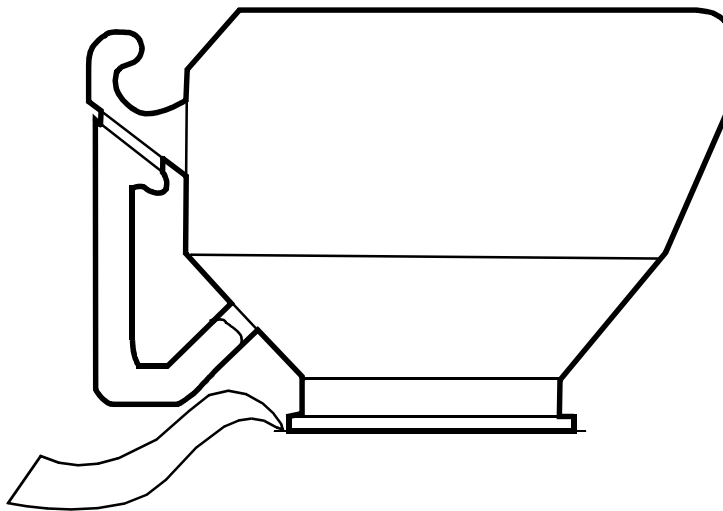
**Figure 4-12** Locate dry ink area

2. Place a dropcloth on the floor under the dry ink area.
3. Pull the empty dry ink cartridge out until it stops.
4. Move the green handle to the right (the unlatched position) to release the cartridge and lid.



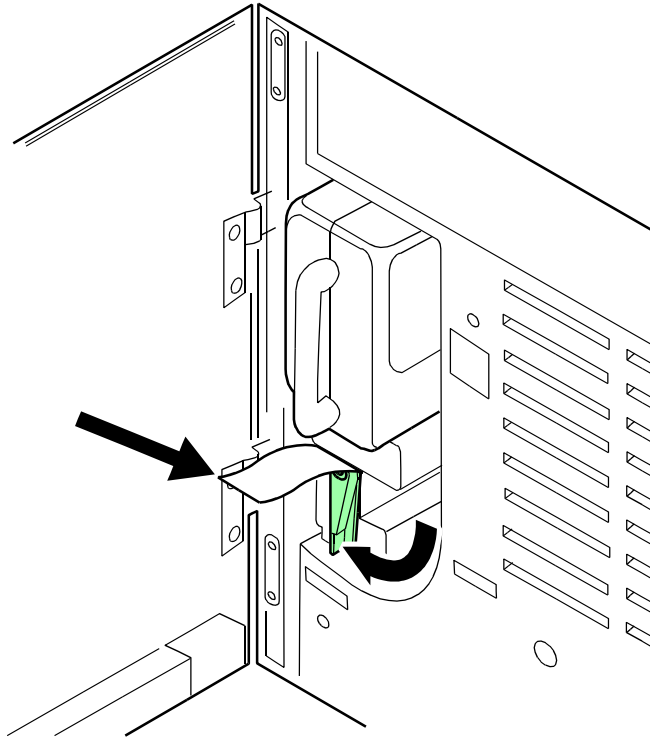
**Figure 4-13 Move green handle to right**

5. Remove the empty cartridge and discard it.
6. Turn a new, full cartridge of dry ink upside down and shake it well to loosen the contents thoroughly.
7. Insert the new cartridge into the printer until it stops.



**Figure 4-14 Insert new cartridge**

8. Move the green handle to the left (the latched position) to secure the lid of the cartridge.



**Figure 4-15 Move green handle to left**

9. Hold the cartridge in place and pull off the paper seal.
10. Discard the seal along with the drop cloth.
11. Close the printer doors.



**NOTE:** *If any dry ink gets on your hands, wash them with soap and cold water. Heat sets the ink permanently. If any dry ink gets on your clothes, brush them with a dry paper towel or a stiff bristled brush. If this does not remove the ink immediately, launder with detergent and cold water. Dry cleaners should be told that the spot is dry ink for a printer, so they will not use a solvent that sets the stain.*

## Using the custom transfer assist blade

The custom transfer assist blade in the printer assures good print quality for your jobs. A kit is available allowing you to customize the transfer assist blade for use with nonstandard paper sizes.

You cannot use the custom transfer assist blade for print jobs that use more than one paper size. In addition, the following paper lengths cannot use the blade:

- In U.S. markets
  - 11.1 to 11.4 inches/282 to 290 mm
  - 11.8 to 12.1 inches/300 to 307 mm
  - 13 to 13.5 inches/330 to 343 mm
- In non-U.S. markets

- 11.1 inches to 11.4 inches/282 to 290 mm
- 11.8 inches to 12.1 inches/300 to 307 mm



**NOTE:** *With these paper sizes, transfer efficiency may be reduced.*



**CAUTION:** *To avoid damage to the photoreceptor, you must perform the Setting tray size with the transfer assist blade*

**Installing the custom transfer assist blade**

The custom transfer assist blade comes in a package containing detailed instructions. Be sure you follow the instructions carefully.



**CAUTION:** *To prevent damage to the system, have your service representative show you the procedure before you attempt to customize and install a transfer assist blade for the first time.*

**Setting tray size with the custom transfer assist blade**

When you are using the custom transfer assist blade, you must set the tray length. Use the following two tables to determine the tray length setting to use.

**Table 4-2 US tray length settings for custom transfer assist blades**

Paper Size	Set Paper Size to
11.5 to 11.7 inches/292 to 297 mm	11.7 inches/297 mm
12.1 to 12.9 inches/307 to 328 mm	13 inches/330 mm
13 to 13.9 inches/330 to 353 mm	14 inches/356 mm

**Table 4-3 Non-US tray length settings for custom transfer assist blades**

Paper Size	Set Paper Size to
10 to 10.9 inches/254 to 277 mm	11 inches/279 mm
11.5 to 11.6 inches/292 to 294 mm	11.7 inches/297 mm
12.1 to 12.9 inches/307 to 328 mm	13 inches/330 mm

## Cleaning the system and its components

Cleaning tasks consist of the following:

- Cleaning the 18/36-track cartridge tape drive
- Cleaning the 26-track cartridge tape drive
- Cleaning the DVD drive
- Cleaning the diskette drive

- Cleaning the sensors and the reflecting surfaces
- Cleaning the display
- Cleaning the exterior surfaces of the system

## Cleaning the 18/36-track cartridge tape drive

A cleaning cartridge is shipped with each 18/36-track cartridge tape drive. This cartridge should be replaced after 500 uses.

When the tape drive needs to be cleaned, CLEAN appears in the message display after a cartridge is unloaded and during a rewind or locate operation.



**NOTE:** *CLEAN is a status message, not an error message.*



**CAUTION:** *Never power off the tape drive without following the cleaning procedure once the CLEAN message has appeared.*

To clean the 18/36-track cartridge tape drive read/write heads:



**CAUTION:** *The cleaning cartridge must be undamaged and clean.*

1. Remove any cartridge loaded in the tape drive.
2. Insert the cleaning cartridge.  
The cleaning cycle takes approximately 15 seconds.
3. Remove the cleaning cartridge when it is unloaded.
4. Mark the usage on the tape label. Do not use a grease pencil.

You must clean the 18/36-track cartridge tape drive regularly to keep it functioning properly.

## Cleaning the 26-track cartridge tape drive

The 26-track, or quarter inch cartridge (QIC) tape drive heads should be cleaned at least once a week. If you use the drive for eight hours or more per day, then you should clean the drive daily. The process is simple and requires very little time.

1. If there is a cartridge in the tape drive, remove it.
2. Insert the cleaning cartridge into the tape drive and close the door. Cleaning begins automatically once the cartridge is inserted.
3. Allow the tape to run for approximately 30 seconds, then remove it.



**NOTE:** Replace the foam pad on the cleaning cartridge after it has been used three times. The cleaning cartridge itself can be used approximately 100 times.

## Cleaning the DVD drive

---

Follow the DVD cleaning directions and recommended cleaning frequency.

1. If there is a DVD disk in the drive, remove it.
2. Follow the directions to clean the DVD drive.

## Cleaning the diskette drive

---

The floppy disk drive must be cleaned at recommended intervals to prevent read and write errors.

To clean the diskette drive:

1. If there is a diskette in the floppy disk drive, remove it.
2. Insert the cleaning diskette into the disk drive.
3. Follow the directions on the cleaning diskette to clean the diskette drive.
4. Remove the cleaning diskette.

## Cleaning the sensors and the reflecting surfaces

---

The following is a list of sensors to clean:

- Q850 sensor
- Q1011 sensor and mirror
- Q1106 sensor
- Q1166 sensor
- Q1107 sensor
- Q1164 sensor

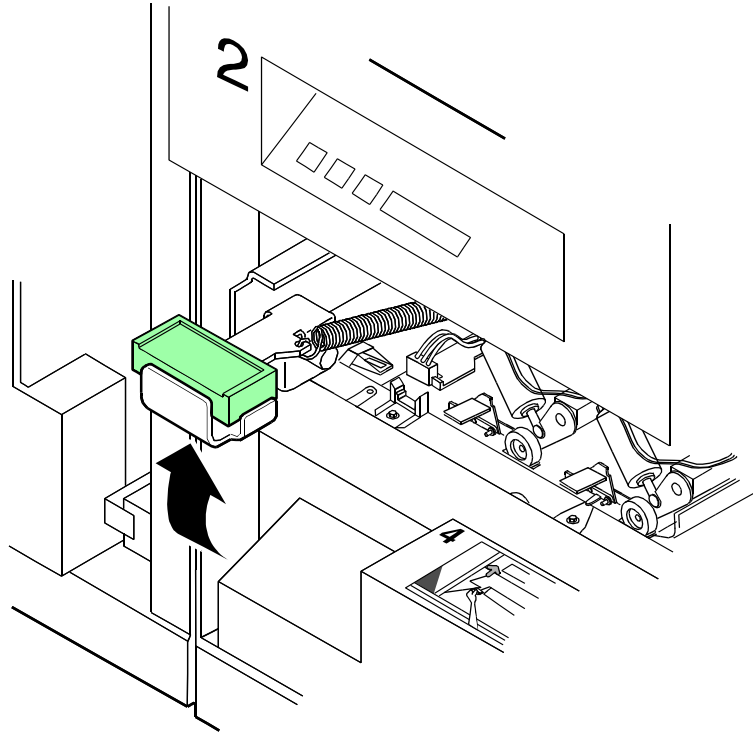
### Cleaning the Q850 sensor

---

Follow this procedure when directed by Xerox Customer Support Center personnel.

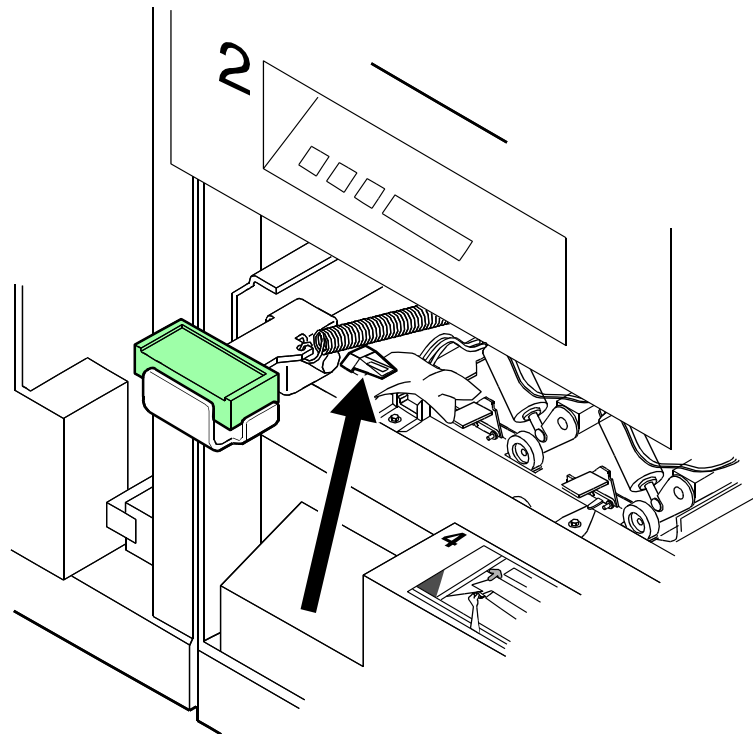
1. Open the right and left doors of the printer and locate area 4.
2. Raise the area 4 green handle until it locks into place.





**Figure 4-16** Raise area 4 green handle

3. Locate the Q850 sensor.



**Figure 4-17** Q850 sensor

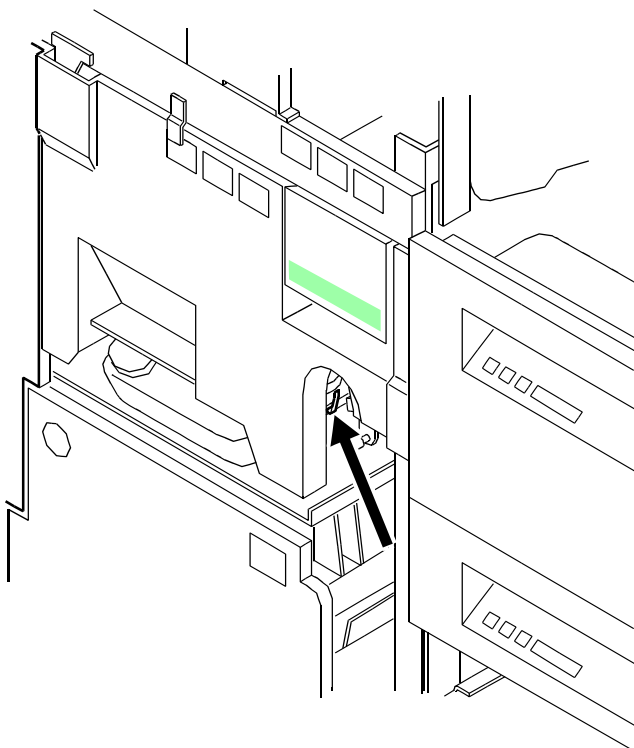
4. Place a dry cleaning pad on the sensor and move it from left to right to clean the sensor.
5. Lower the area 4 green handle.
6. Close the printer doors.

### Cleaning the Q1011 sensor and mirror

---

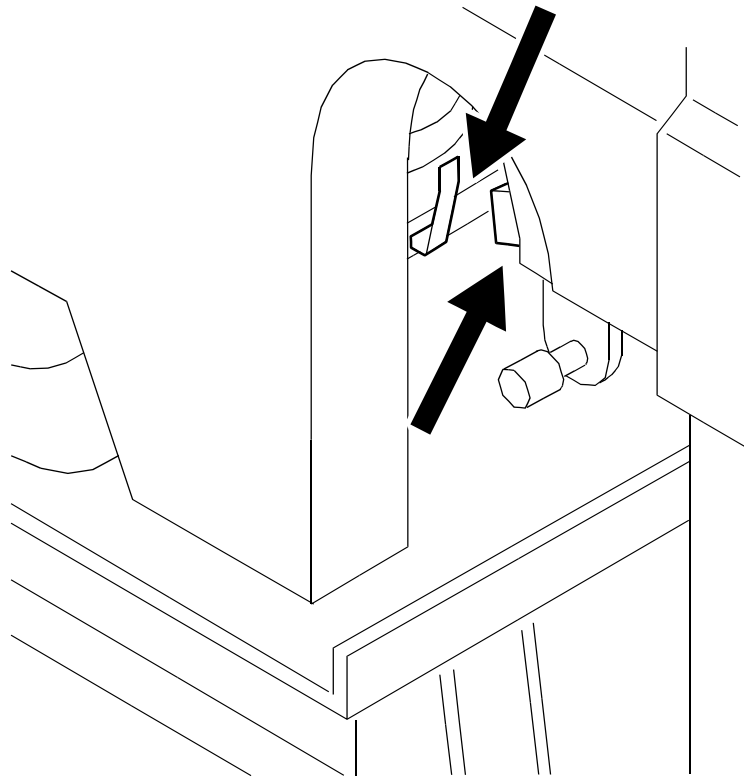
Follow this procedure when directed by Xerox Customer Support Center personnel.

1. Open the right and left doors of the printer and locate the Q1011 sensor.



**Figure 4-18 Q1011 sensor**

2. Apply a small amount of lens and mirror cleaner to a cleaning pad.
3. Wipe the sensor and mirror gently with the cleaning pad.



**Figure 4-19 Gently wipe sensor and mirror**

### **Cleaning additional sensors**

---

There are additional sensors that you should clean when directed by Xerox Customer Support Center personnel.



**NOTE:** *If the sensor is very dirty, you may use a small amount of alcohol on a swab to clean it.*



**CAUTION:** *Do not use any abrasive materials or stronger solvents on the sensor.*

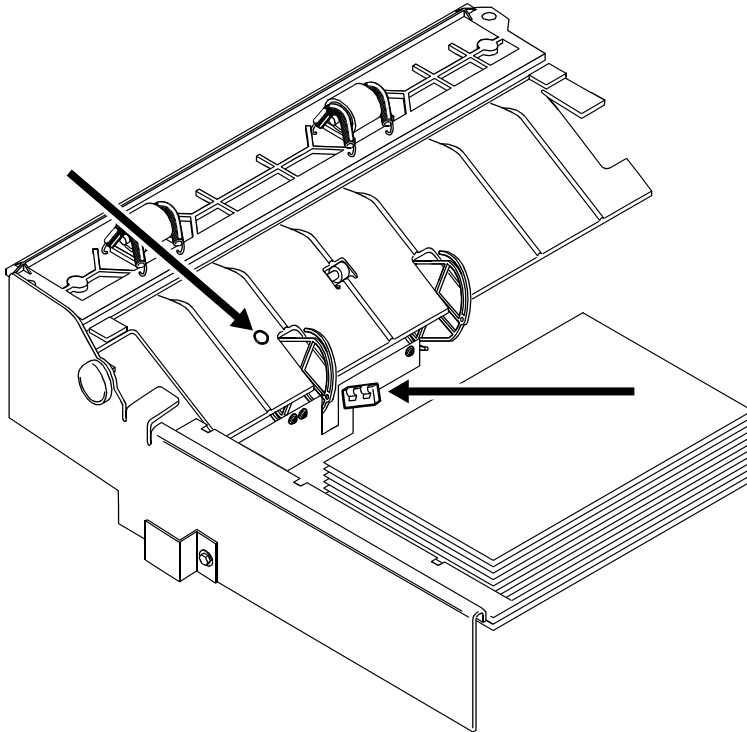
### Cleaning the Q1106 and Q1166 sensors

---

To access sensors Q1106 and Q1166, open the top cover of the high capacity stacker.

To clean the sensors:

1. Brush or wipe the sensor windows lightly.
2. Remove any paper dust present in the area.



**Figure 4-20** Remove paper dust

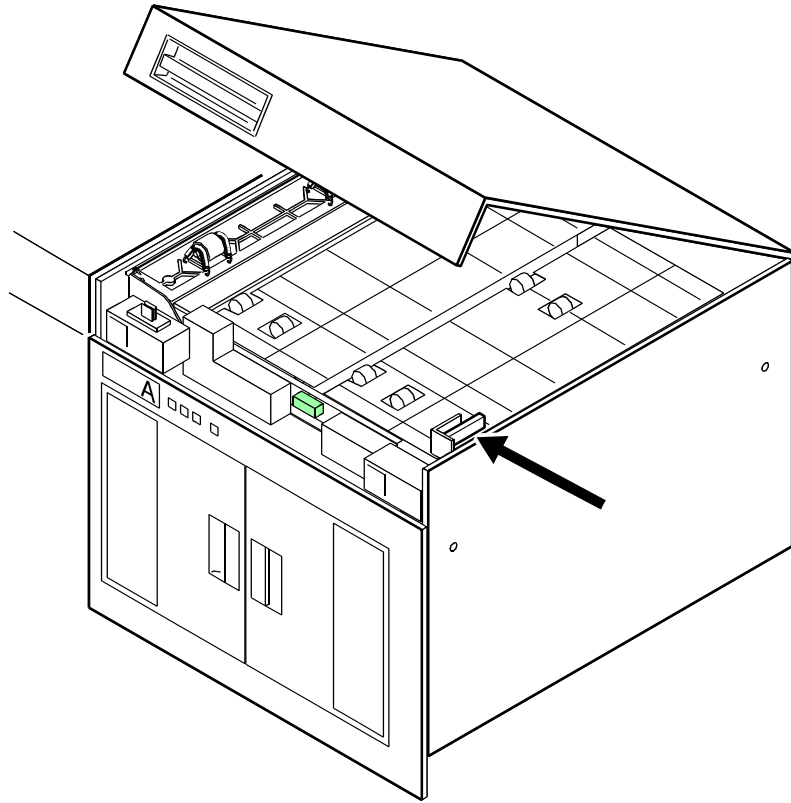
### Cleaning the Q1107 sensor

---

To access sensor Q1107, open the top cover of the high capacity stacker.

To clean the sensor:

1. Brush or wipe the sensor window lightly.
2. Remove any paper dust present in the area.



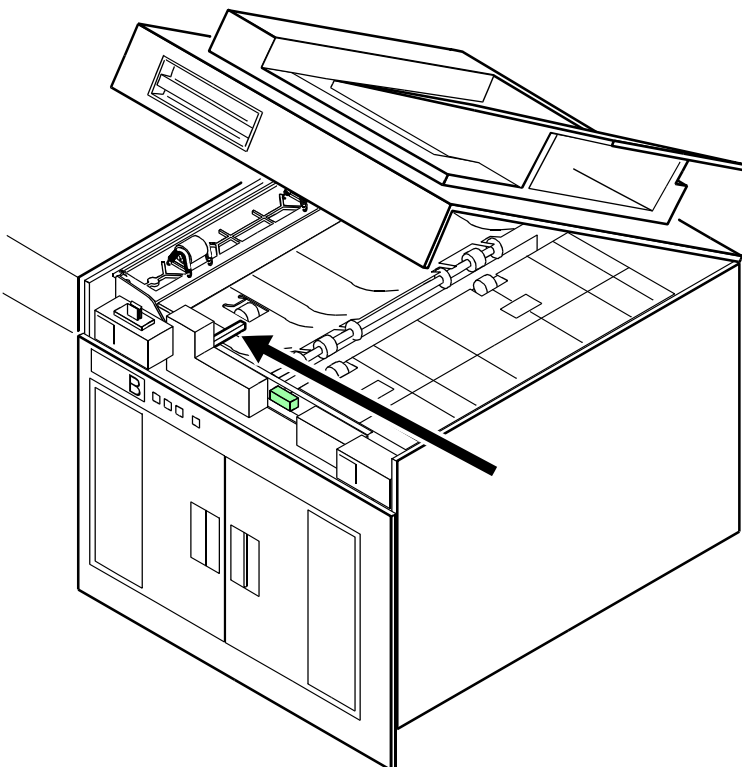
**Figure 4-21 Clean Q1107 sensor**

### **Cleaning the Q1164 sensor**

To access sensor Q1164, open the top cover of the last feeder/stacker module (the one containing the purge tray).

To clean the sensor:

1. Brush or wipe the sensor window lightly.
2. Remove any paper dust present in the area.



**Figure 4-22 Clean Q1164 sensor**

## Cleaning the display

---

The display should be cleaned as required.

Clean the display with a soft, lint-free cloth dampened with a glass or lens and mirror cleaner. Do not spray the liquid directly onto the display because it may cause damage.

## Cleaning the exterior surfaces of the system

---

Clean the exterior surfaces of the printer daily, if possible.

Clean the exterior surfaces with a mild household detergent that has been poured or sprayed onto a cloth lightly dampened with water. Do not saturate the cloth; just dampen it.



**CAUTION:** *Liquids must not be allowed to drip onto anything electrical or mechanical. For the same reason, never spray or pour the cleaner directly onto the keyboard or the exterior surfaces of the system.*

# 5 Troubleshooting

This chapter contains instructions for performing problem isolation and resolution, including paper jams.

## Undeclared faults

---

Undeclared faults are problems that occur with no message displayed at the client workstation and no fault declared by the system software.

### Problem classifications

---

Problems that may occur on the system can be categorized as follows:

- **Client problems:** Client problems includes job submission problems with no message displayed at the client workstation.
- **Graphical User Interface (GUI) problems:** Graphical User Interface (GUI) icons or windows do not appear correctly, do not operate correctly, or disappear suddenly.
- **Print quality:** The output from the printer contains image defects such as deletions, problems with lines, missing images, smudges, shading, or text problems.
- **Font problems:** The output from the printer contains font defects, such as incorrect character spacing, jagged characters, text runs off the page, or sentences run into each other.
- **Inoperable system:** The inoperable system has experienced an unrecoverable software error due to a job or operator action.
- **Job flow:** Jobs sent from the client are not received at a printer queue.
- **Job integrity:** Job Integrity means the output from the printer is not as expected, such as having missing pages, missing data, incorrect page orientation, incorrectly ordered sets, or job attribute inconsistencies.
- **PDL problem isolation:** The PDL problem isolation procedure provides questions that a System Administrator may ask the job submitters when they are experiencing problems with printing.

- **Process problems:** A process was followed incorrectly or unintentionally.
- **Productivity and performance:** Productivity/performance problems means the job takes an excessive amount of time to complete.
- **Save problems:** A job is submitted from a client with [Save] designated, but the job is not saved.

## Troubleshooting client problems

---

Client problems are handled differently, depending on the client platform used.

After determining the type of problem, follow the appropriate procedure. If the problem still exists after completing the procedure, contact the customer support center for assistance.

### Solving FreeFlow Prepress problems

---

**Problem:** A job that is submitted from a 2.5 client does not print.

1. Systems using DigiPath 2.5 or jobs from 2.5 clients should upgrade the client. Contact the local support center for information.

## Troubleshooting Graphical User Interface (GUI) problems

---

Use the following procedures when the Printer Manager, Queue Manager, Job Manager, Administration, or Help modules do not function, or you cannot use Exit to restart the system.

- **Problem:** One of the icons on the DocuSP Print Services window is selected and does not respond or suddenly disappears.
  1. Restart the software.
- **Problem:** The GUI comes up with a black background, and the label names do not display correctly.
  1. Determine if the `/opt/XRXnps/XRXservui/data/locale/<locale*>/resources` directory exists.
    - Determine if there are files in the directory.
    - Determine if the users have read permission for the files.
  2. Determine if the `/opt/XRXnps/XRXservui/data/ui.mn.config` file exists.
  3. If the `/opt/XRXnps/XRXservui/data/locale/<locale*>/resources` directory or the `/opt/XRXnps/XRXservui/`



`data/ui.mn.config` file do not exist, set the XAPPLRESDIR environment variable by entering the following:

```
setenv XAPPLRESDIR/opt/XXnps/XXservui/
data/locale/<locale>resources
```

**NOTE:** *\*\*<locale> is the locale of your server:*

- en\_US for U.S. English
- fr for French
- es for Spanish
- de for German
- it for Italian
- ja for Japanese
- po for Portuguese
- ne for Dutch

## Troubleshooting print quality problems

A print quality problem means that the job was submitted successfully, but does not print correctly.

**NOTE:** *If the Image Quality parameters are changed, you must restart or reboot the DocuSP software in order for the changes to take affect.*

**NOTE:** *The image quality default settings are optimized for the printer. If changes have been made, you can restore the factory installed defaults by selecting [Defaults].*

*Selecting [Reset] sets the image quality parameters to the most recently applied setting.*

### Resolving print quality problems on a PostScript job

To isolate and resolve a print quality problem on a PostScript job, perform the following:

- Determine if an error page has been printed.

**NOTE:** *If error pages are not enabled, you can enable error pages and resubmit the job, or obtain the information from the `/opt/XXnps/log/errorLogs` directory. This directory contains `error.##.log` files, where `##` corresponds with the Job ID number. Note the Job ID number from the printer queue and read the corresponding error log.*

- Submit the job to a draft PostScript printer, if one is available, to determine if the master is valid.
- Ensure that jobs are being sent to the correct queue.

- Ensure that a valid PDL is used; for example, an Adobe driver outputs a valid PDL file in PostScript format.



**NOTE:** *Gray scales or graphic images may contain image quality differences if they are printed using a 300 dpi decomposer.*

### Isolating and resolving printer-driven print quality problems

**Problem:** The output from the printer contains defects such as deletions, line problems, and missing images.

- Determine if the job has ever been printed correctly on this system.
- If possible, print the job on a draft printer. If the job prints correctly, contact the customer support center.
- Determine if other jobs are exhibiting the same problem. This could indicate a printer problem. Contact the customer support center.
- Recreate the job with a different print driver and resubmit it to the printer.

### Resolving font problems

Use the following procedures to isolate and resolve common font problems.

- **Problem:** The job prints with the wrong font.  
Determine if the font is being downloaded with the job. If a downloaded font is not found, font substitution occurs and an error page is printed.  
If the font is not being downloaded with the job, determine if the font is loaded on the server by viewing the PostScript/PCL Fonts tab on the Administration window.
- **Problem:** Characters appear jagged.  
Determine if there is a scalable option available for that font and whether the user selected that option.
- **Problem:** Some incorrect characters print.  
Determine if the document was created with one driver and printed with another driver.
- **Problem:** Text runs off the page, or sentences run into each other.  
Determine if the document was created with one driver and printed with another driver.
- **Problem:** Small fonts are printing ragged.  
Change the default font renderer in the Printer Manager from Adobe Type Manager to Font Solution.



**NOTE:** If you are comparing prints from a proof printer, ensure that the same PDL file was used to make the prints on both printers.

## Troubleshooting job flow problems

- **Problem:** A PostScript, ASCII, or TIFF job displays a status of Processing, and does not print.
  1. Hold the job.
  2. Submit the job to a draft PostScript printer, if possible, to determine if the master is corrupted.
  3. If the job prints, contact the customer support center.
- **Problem:** A job that does not have faults has been submitted and is not printing.
  1. Shut down, then restart the DocuSP software.



**NOTE:** After the restart, the job either processes or faults.

- 2. If the banner or error pages are enabled, determine if the **-admfac** process is active.
- **Problem:** An active job with a status of “printing” or “waiting for printer” is not printing and there are no faults or messages.
  1. Open a printer door. If a message appears in the faults and messages frame, the controller is communicating with the printer.
  2. If you determine that the job is taking too much time, restart the DocuSP software.

## Troubleshooting job integrity problems

A job integrity problem means that the output from the printer is not as expected; for example, missing pages, missing data, incorrect page orientation, incorrectly ordered sets, or job attribute inconsistencies.

- **Problem:** The job does not print as expected:
  1. Check the job properties to determine if the job was programmed correctly.
  2. Check for any queue override attributes.
  3. If the job is a PCL or a PostScript job, check the file for job ticket information.
  4. Resubmit the job from the client.
  5. If possible, recreate the job.
- **Problem:** Jobs are printing in reverse order.

- Verify that your PDL file was created without reverse order instructions.
- Verify that the application was not set up to print in reverse order.

## Troubleshooting PDL problems

---

The problem isolation for PDL problems procedure provides questions that the system administrator may ask the job submitters when they are encountering problems with printing PDL files. The answers to these questions will assist in isolating the problem.

### Isolating HP PCL file problems

---

Ask the following questions when there are problems with HP PCL files:

- What printer driver was used to create the file?
- What application was used to create the file?
- Do all applications create this file format?
- Have you tried selecting a different driver to create this type of file? If so, did it print without problems?
- Has the file been printed previously on a different printer? If so, what printer was selected?
- Because HP PCL printers rarely print a list of errors, what do you see as the specific image errors or problems in the prints?
- When you compare the problem prints with a hard copy proof, what specifically do you need to correct?
- Was the file recreated and resubmitted? If so, what was the result?
- Especially for large jobs, has the file been submitted to a queue that is accepting files and is clear of problems, or for which resources were available and adequate?
- Did this file or similar files print on a previously installed version of the system software?
- Has printing been attempted with the most recent version of the system software?

### Isolating PostScript file problems

---

Ask the following questions when there are problems with PostScript files:

- What printer driver was used to create the file?
- What client/application was used to create the file? Do all

applications create this type of file?

- Was the file recreated and resubmitted with a different driver (for example: 6135 driver, Adobe with the 6135 PPD, LaserWriterII NTX, Linotronic330, or DT135)? If so, what was the result?
- Has the file been printed on a second PostScript printer (for example: on another printer, a true Adobe PS2 printer)?
- Is there a printed PostScript error page. If there is one, what errors are listed?
- Was the file recreated and resubmitted? If so, what was the result?
- Especially for large jobs: Has the file been submitted to a queue that is accepting files and is clear of problems, and for which resources were available and adequate?
- What do you see as the specific image errors or problems in the prints?
- When you compare the problem prints with a hard copy proof (for example, from a true Adobe2 printer), what specifically do you need to correct?
- Did this file or similar files print on a previously installed version of the system software?
- Has printing been attempted with the most recently released version of the system software installed?

### Isolating TIFF file problems

Ask the following questions when there are problems with TIFFS:

- Is the file a true TIFF or is it a TIFF wrapped in PostScript as determined by viewing the file in a text editor and checking the PostScript header?
- Did the PostScript error page list the error as "Decomposition Task Failed" to indicate that the tags and compression formats of this file are not supported?
- What type of client and application was used to submit the file?
- Was the file created using FreeFlow PrePress Suite, or using generic image manipulation software (for example: Corel, PhotoShop, or Word) or did it originate from a scanner?
- Can the TIFF image be viewed using any software package (for example: Corel, PhotoShop, ImageWiz, Word, or FreeFlow)?
- Has the file been recreated and resubmitted?
- Does the error page list errors such as "image mask," "Xeroximage," or "image" to indicate that the FTP transmission of the file has corrupted the TIFF image data?
- If the file has an orientation problem, has an attempt been

made to change the orientation using the Xerox Client Software print command orientation switch, <orientation>?

Additional TIFF questions:

- What compression format was used to compress the file (for example: group 3, group 4, packbits, or RLE)?
- What dots per inch (DPI) resolution was used or intended for the file (for example: 300 dpi or 600 dpi)?
- What TIFF specification was used or intended for the file (for example: TIFF Spec. 5.0 vs. TIFF Spec. 6.0)?
- Did this file or similar files print on a previously installed version of the system software?
- Has printing been attempted with the most recent version of system software installed?

### Isolating PDF file problems

---

Ask the following questions when there are problems with PDF files:

- Did you try creating the PDF from the original PostScript through the latest version of Adobe's PDF Distiller?
- Does the original PostScript file print correctly? If yes, does it print correctly on other PostScript printers?
- Can you open all pages within Adobe's Acrobat? Within Acrobat, can you print correctly from PostScript?
- What application and/or PDF software created the PDF file?
- With the printer's error pages turned on, does the printer produce a PostScript error page?
- Does the PDF file print on other PDF printers?
- Have you tried printing the PDF file using the most Current release of system software?
- Have you tried redistilling the PostScript file again?
- Have all the document fonts been downloaded and included throughout the process? Keep in mind that the fonts have to be within the PostScript and the resulting PDF.
- Did you use PDF Writer to create the PDF file? If so, recreate the PDF file using Adobe's PDF Distiller.

### Troubleshooting process problems

---

Process problems mean that a procedure is followed incorrectly or performed by mistake.

- **Problem:** [Exit] was selected from the System menu in error.  
To start the DocuSP software without rebooting the controller:

1. Open a terminal window and enter the following:

```
cd /export/home/xrxusr
.openwin-init
```



**NOTE:** No special logon is required to restart the Xerox software.

- **Problem:** You forget the Operator or Administrator password.

1. In a terminal window, enter the following:

```
cd /opt/XXnps/XXservui/data
ls -la
```

2. Delete the following files:

- .npw
- .sum



**NOTE:** You must be logged in as “root” to delete these files.



**NOTE:** You must enable the Accounting Remote Purge utility again.

## Troubleshooting productivity and performance problems

When the job seems to take too much time to process through the system, there may be a productivity or a performance problem.

1. Check the job status in the Job Manager window.
2. If the job status is <hold>, right click on the job list and select [Release] from the pop-up menu.

If the job status is <processing>, do the following:

- Check the Print Services window. If the job is processing, you should see a message:

```
input to printer delayed
```

You can also check the performance meter. If the CPU activity is high, the decomposer is working.

- If you have no message in the Print Services window or the CPU activity is low on the performance meter, the process has been stalled. Restart the DocuSP software.
3. Submit the job to a draft printer, if possible, to determine if the master is valid.
  4. If the job prints on a draft printer, contact the customer support center.

If you have any removable peripherals (DVD player, tape drives, and so on) connected to the controller, keep the peripheral devices powered on, even when they are not in use.

## Troubleshooting problems with saving jobs

---

A save problem means that a job is submitted from a client with Save designated, but the job is not saved.

- **Problem:** The job has a status of “Save Completed,” but nothing is saved.
  1. Ensure that the banner and error pages are enabled.
  2. Submit the job for printing.
  3. If only the banner page prints and the job shows a status of “Successfully Completed,” check the PDL file for invalid “showpage” operators or no image data.
  4. If possible, submit the job to a draft printer. If the job prints successfully, contact the customer support center.
- **Problem:** The job has a status of “Save Completed with errors,” but nothing is saved:
  1. Ensure that the banner and error pages are enabled.
  2. Submit the job for printing.
  3. Check the error page for the information following the statement “OFFENDING COMMAND” to correct the PDL file if it is corrupt.
  4. If possible, submit the job to a draft printer. If the job prints successfully, contact the customer support center.
- **Problem:** You are receiving PostScript error messages while trying to merge variable data with the form.

Create the variable data file by using the Adobe driver.

## Crash recovery

---

This section explains how to recover a job after a system crash or rollover, in Streaming and Spooling modes.

### Streaming mode

---

In Streaming mode, the printing system begins processing (decomposing and printing) the data stream as soon as a minimum amount of data is received, and continues to process the data as it is received.

If the system crashes **during** the printing of an LCDS report, the software tries to recover to a page boundary. If this recovery is successful, you do not notice anything different with the output of your recovered report, but you are asked to restart the system after a crash. The recovered page may be offset from the rest of



the report if you specified ABNORMAL REPORT = YES for that report. (For more information, refer to the *Xerox Document Services Platform Using LCDS Print Description Language*).

If the system cannot completely recover an LCDS report (due to data loss or missing online records) after a crash, it ends the job and prints all remaining formatted reports. A message on the screen notifies you that the job completed with errors.

## UI recovery messages

---

After a crash, the Printer Faults window displays a short recovery-related message. Double clicking on the message opens the Printer Fault Clearance window, which displays a detailed message including clearance instruction for that selected fault. You have the option to close the window without taking any action or to perform the appropriate clearance action after which the window closes and the fault is removed from the list.

The system attempts to reestablish the correct state of the system at the time of the crash to assure no loss of formatted data. After the successfully recovered report has completed printing, the accounting log shows the recovered report has completed successfully and the total pages is the maximum number of pages in the report (even if the job ended early).

The following four examples illustrate the short and long messages associated with a crash.

## Recovery message examples

---

### Example 1 Short message:

```
Online Gateway could not recover the
current job due to data loss.
```

### Long message:

```
The Online Gateway was unable to recover
the current job due to data loss.
```

```
Job <job ID> ended prematurely.
```

```
Select Reset to clear fault.
```

This message displays when the online gateway cannot completely recover after a crash recovery and ends the job. The job status shows that the job completed successfully. If the job specifies an accounting page, the page is generated. The accounting log displays the Job Completed status.

### Example 2 Short Message:

```
Online Gateway could not recover the
current job due to an internal error.
```

### Long Message:

```
The Online Gateway was unable to recover
the current job due to an internal error.
```

```
Job <job ID> aborted.
```

```
Select Reset to clear fault.
```

This message displays when the Online gateway encounters an internal error during a crash recovery and the system aborts the job. The job status shows the state of the job. If the job specifies an accounting page, the page is generated. The accounting log displays the Job Aborted status.

### Example 3

#### Short message:

```
Job <job ID>: LCDS Decomposer could not
recover data. Job will be ended
prematurely.
```

#### Long Message:

```
Job <job ID>: LCDS Decomposer could not
recover data. Job will be ended
prematurely.
```

This message is displayed when the LCDS Decomposer encounters an internal error during recovery. Upon clicking Continue in the Printer Fault Clearance window, the job is aborted. The job status shows the Job Aborted state. No accounting page is generated.

## Spooling mode

---

In Spooling mode, a job does not print until all its data is received. If the system crashes **after** spooling all the data, follow the directions for Streaming mode. If the system crashes **while** receiving data, the job is aborted.

After a crash, wait until the system is idle before restarting. Wait for the printer engine to cycle down and make sure that the Job Manager shows no changes in the job state.

### Points to note

---

- If automatic recovery is possible and the same system fault occurs twice within the report, the system prints any formatted reports, but aborts the current job. If there are system faults that do not result in restarting the system, the system does not print the reports.

Automatic recovery refers to restarting of the system software following a system fault such as when a critical component dies.

- You may change the buffer size that determines how many

records the system can hold in case of a crash recovery. Change the size through the Online Setup window. (Refer to the online help for more information.)

- A reset or a power off can occur if the Solaris operating system opens or loses files or directories to the printing system, and the system is left in an inconsistent state with its persistent memory.
- In case of a power off, perform a UPS (for FX markets only).
- When a restart or immediate shutdown occurs in the middle of an LCDS report, the LCDS job is aborted upon recovery.

## Clearing online print data

---

If the system crashes with an online job stuck at the host, purge the print data from the host queue. (The software problem that caused the crash also causes this data to remain.)

1. Click the Queue Manager icon.
2. Right click on a queue, and select [**Properties**] from the pop-up menu.
3. On the Properties window, select [Spooling] as the input mode, and click [**Apply**].
4. Right click on the queue again, and select [**Do Not Release Jobs**] from the pop-up menu. This prevents the unnecessary processing of the data.
5. Select [**Online Manager...**] from the System menu.
6. On the Online Manager window, select the Output Queue that you set up in the previous steps.
7. Start a new job, and wait until the data transmission is completed.
8. End the job.
9. On the Job Manager window, select the job and delete it.
10. Restore the setup of the queue, if necessary.

The host queue is now clear and the DocuSP software is ready for the next job.

## Online gateway faults/submitting a job from the host

---

When submitting an online LCDS job from a host, access the printer state screen or the output queue screen on the host in order to make sure the job is sent to the printing system correctly. A job completion notification on the host terminal screen or a beep sound does not mean that the job is completely transmitted to the printer; it means only that the data has been queued to the printer

on the host. The actual data transmission from the host to the printer may not have been completed at that point, especially if it is a long job.

Wait until the data transmission is complete before clicking the [End] button on the Online Manager window. Clicking [End] prematurely causes problems such as missing pages or missing lines of data at the end of the job.



**CAUTION:** *If Automatic End is enabled on your system, do not click [End] to finish the job. Doing so could cause loss of data at the end of the job.*

## Obtaining information about a job

---

Follow these steps to determine what is happening to your job after submitting it from the host:

1. Check the job completion message on the host terminal for any JCL errors. If a JCL error occurs, only a banner page prints.
2. Access the printer status window on the host terminal and check whether the printer is active and your job is associated with the printer.

If the printer is in an ACTIVE state, wait until it goes into INACTIVE state. When the printer becomes inactive, the data transmission is complete and you can continue.

3. On the Online Manager window, click the [End] button, if Automatic End is not enabled.

If the printer is inactive, one of following could have happened:

- Your job has been transmitted to the printer already. Continue to step 4.
  - Your job has not been queued to the printer. Skip to step 5.
4. Contact the host operator or access the output queue screen on the host terminal to find out if the job is queued.
    - If the job is queued, the Printer State should be ACTIVE.
    - If the job is queued and the printer is not ACTIVE, there may be a problem at the host.
  5. Access the log screen on the host terminal to check whether the job has completed with or without errors.
  6. Go to the log screen on the host terminal and see if the job completed with or without errors. If there was a JCL error in your job, you see an indication of it.

---

## Data type on the Online Manager window

---

If the Online Manager window indicates a data type that is not LCDS when the streaming job is started, this may cause unpredictable system behavior, such as the window graying out. Make sure to select LCDS as your data type before submitting a job.

---

## Streaming queue release setup

---

When Do Not Release Jobs is specified for the streaming queue, the Online gateway creates a new job, but does not start accepting data from the host. This is because the job is not scheduled while the queue is set up to not release jobs. The gateway does not start receiving data from the host until the job is scheduled and the decomposer becomes ready to accept data. This is not an error or abnormal situation. Change the queue setting to Release Jobs, and the gateway starts receiving data normally.

---

## Incorrect printer state on host

---

**Problem:** The host erroneously indicates that the printer state is ACTIVE.

1. Verify that the device address on the Online Setup window is accurate.
2. Start a new job from the Online Manager window. If the host printer state does not change, continue to step 3.
3. Access the log screen on the host terminal. Check the bottom of the log for a message for your device that is awaiting your response. If there is a message, reply to it.

For example:

```
"/r <msg id>,pn"
```

---

---

## Clearing paper jams

---

The paper path is the route that materials (paper, transparencies, labels, and so on) follow through the printer from the feeder trays to the stacker bins, sample tray, or purge tray. Paper jams can occur at any stage of the paper path. After a paper jam the printer stops, and the following happens:

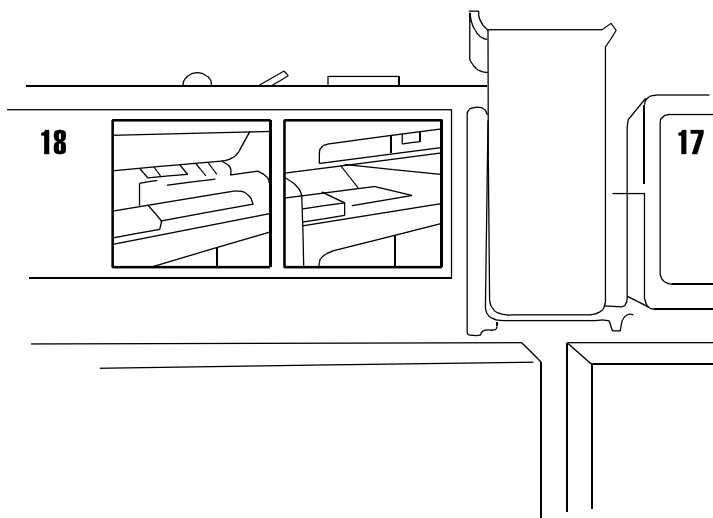
- If enabled, the Attention light flashes.
- The Fault icon appears on the display monitor.

- Messages appear on the display monitor informing you of the paper jam and its location in the printer.
- The printer mimic graphic on the display monitor shows the area of the paper jam and lists instructions for clearing the jam.

## Aids to paper jam clearance

---

Each area of the printer in which jams can occur has detailed jam clearance labels that tell you how to clear a jam in that area.



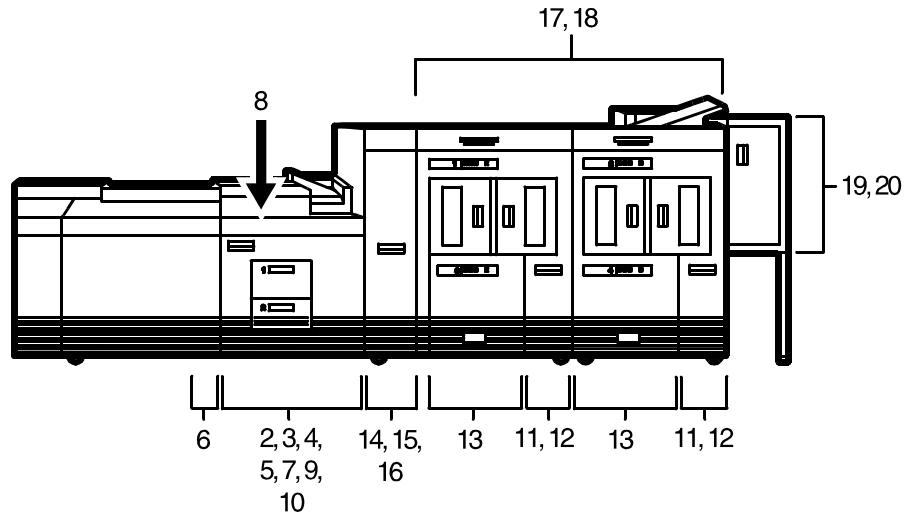
**Figure 5-1 Area jam clearance labels inside the printer**

Each handle, lever, or knob that must be moved to clear a jam is bright green and marked with an arrow indicating the direction it moves.

## Clearing paper jams in all printer areas

---

The following figure gives an overview of the areas in which paper jams may occur.



**Figure 5-2 Jam clearance areas**

To clear a paper jam:

1. Open any printer doors necessary to access the area of the printer indicated by the messages on the display monitor.
2. Clear the jammed sheets from the area, following the instructions on the printer message labels and the messages on the display monitor.



**NOTE:** Occasionally you may find that the printer has already cleared the paper from an area and sent it to the sample or purge trays.

3. Close any printer doors that were opened.
4. Select the Continue button to resume printing.
5. Discard any damaged sheets that were sent to the sample tray or purge tray.

For additional paper jam information, refer to the following sections:

- Checking job integrity following a paper jam
- Clearing paper jams in printer areas 2 through 20
- Clearing a misfeed (feeder tray fault)
- Troubleshooting frequent misfeeds (processor feeder trays)
- Incorrect paper size message

## Checking job integrity following a paper jam

When printing resumes following a paper jam, there is a slight possibility that duplicate sheets may be printed or sheets may be

missing from a report. For that reason, you should check job integrity after the report has been printed.

1. The printer offsets the first sheet printed following a paper jam. Locate that sheet in the stack.
2. Check the sheets immediately before and after the offset sheet to see if there are any missing or duplicate sheets in the report.

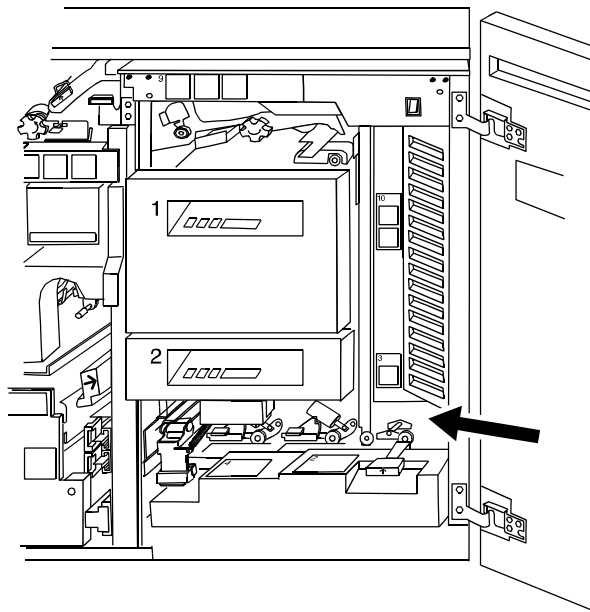


**NOTE:** A message may appear on the controller screen and the display monitor telling you that there is a suspected page delivery error and advising you to check the output.

## Clearing paper jams in printer areas 2 through 20

---

In the following figures, the printer jam clearance areas have arrows pointing to them or circles drawn around them.



**Figure 5-3 Area 2**



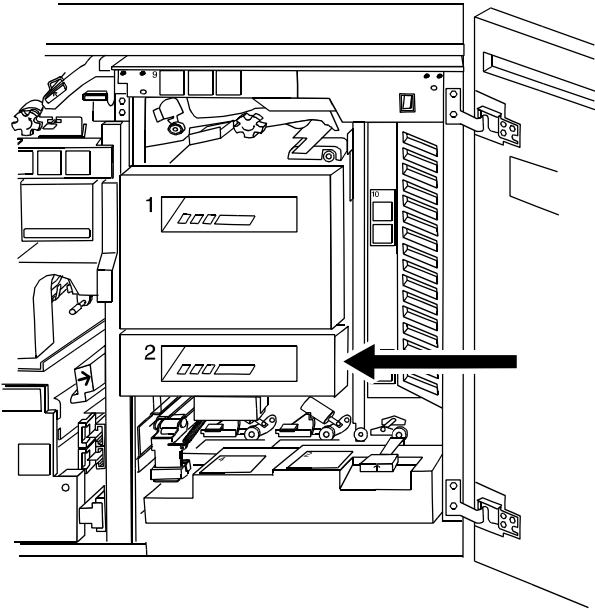


Figure 5-4 Area 3

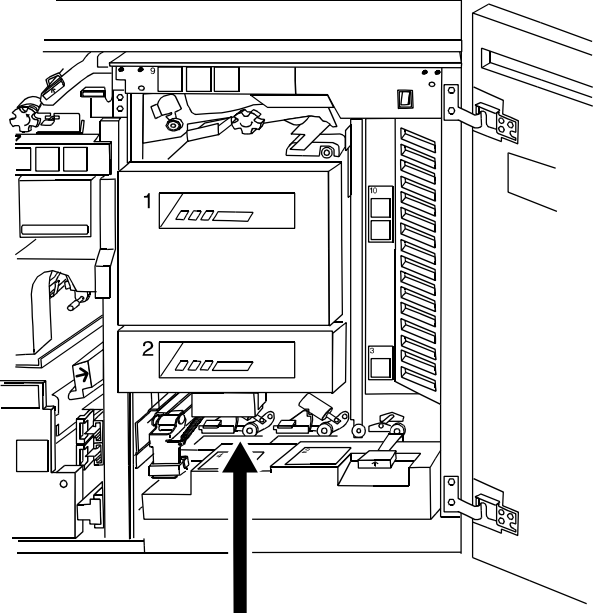


Figure 5-5 Area 4

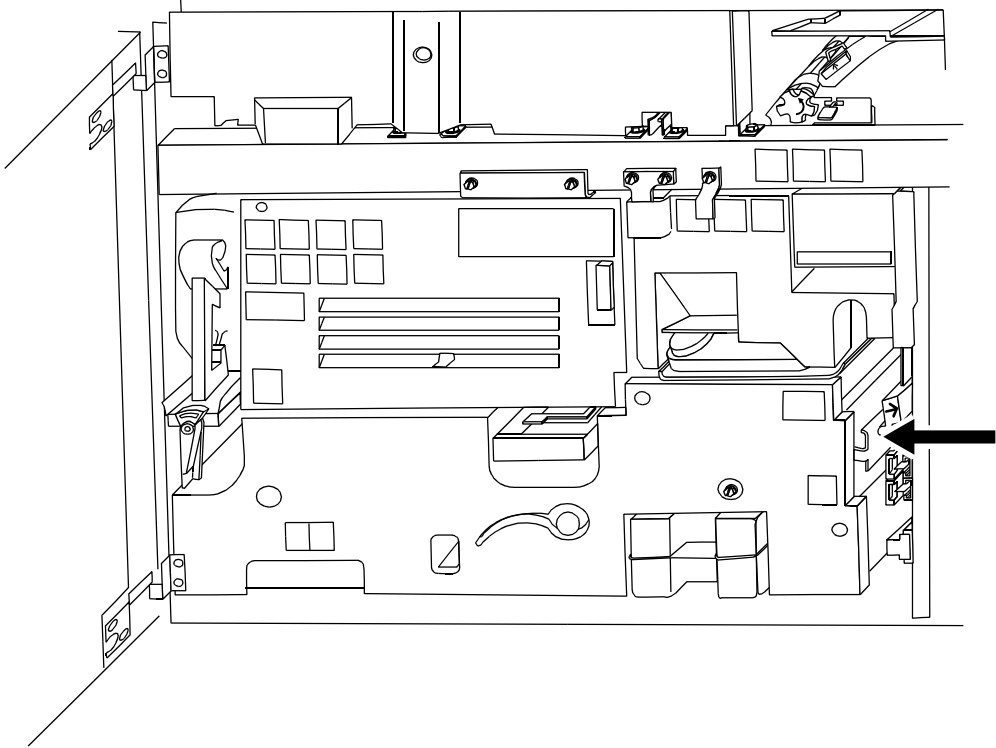


Figure 5-6 Area 5

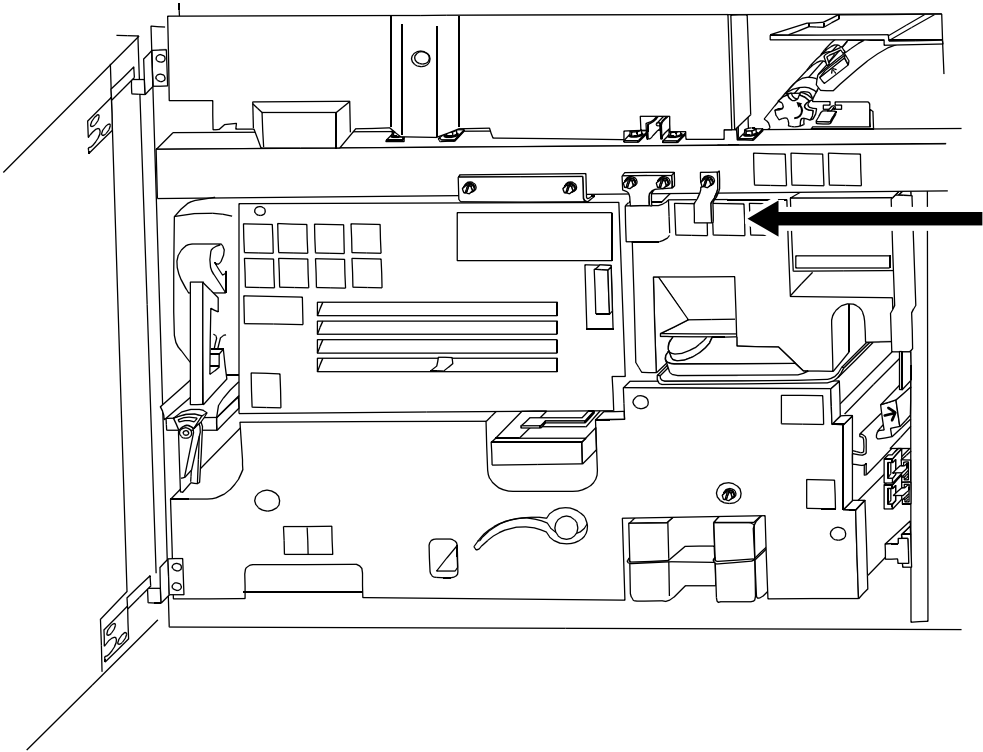


Figure 5-7 Area 6

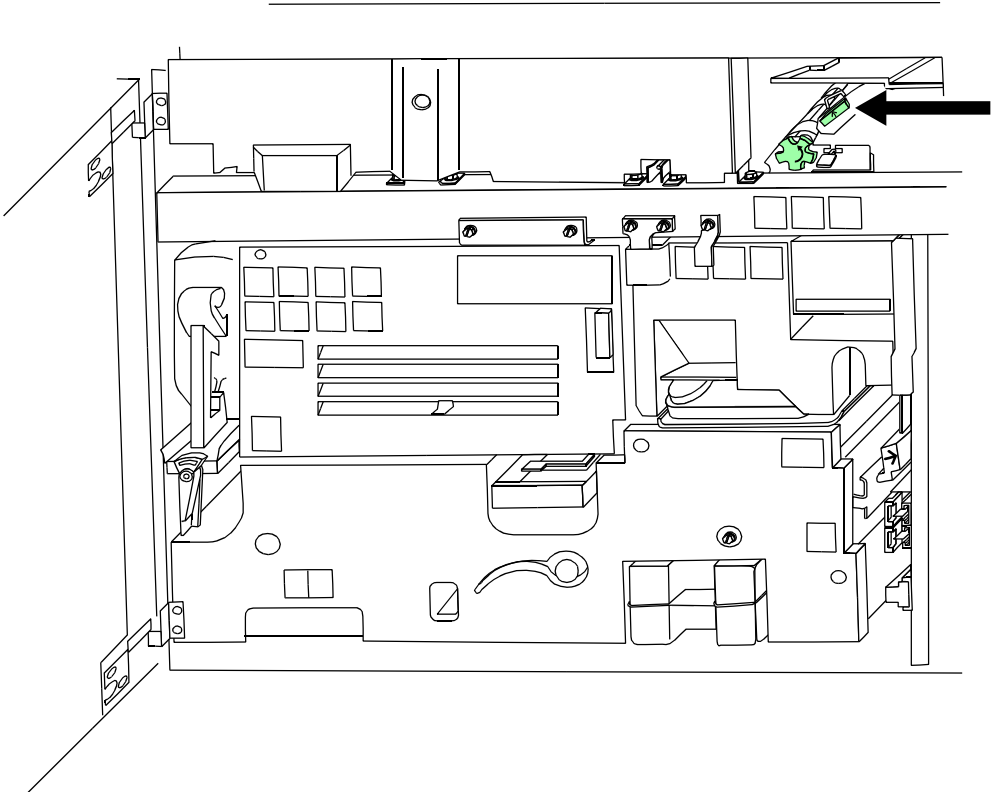
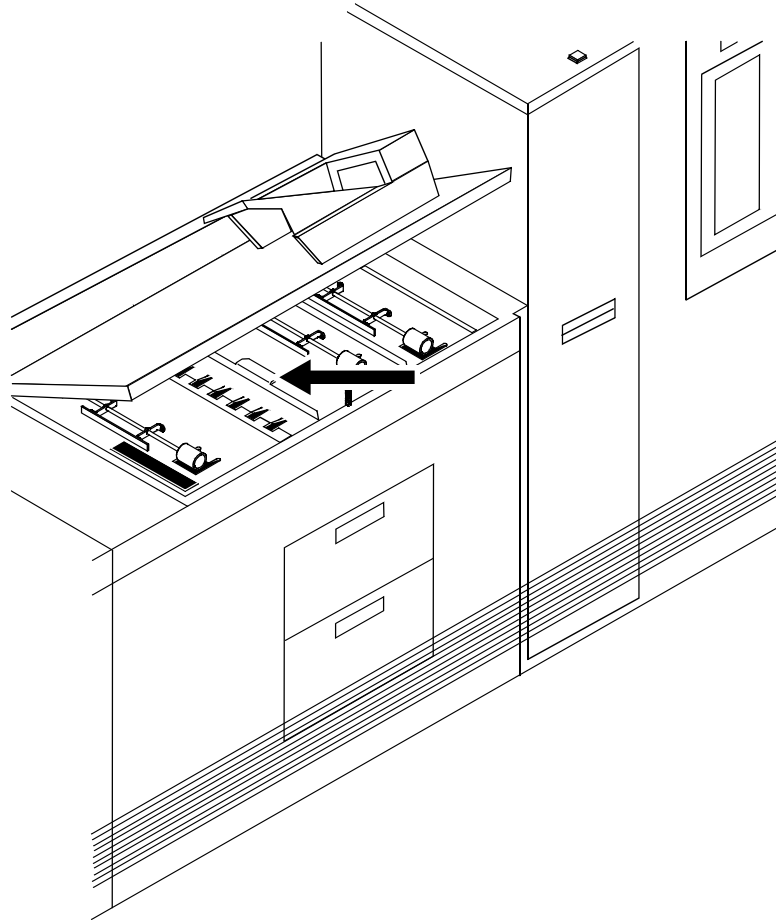


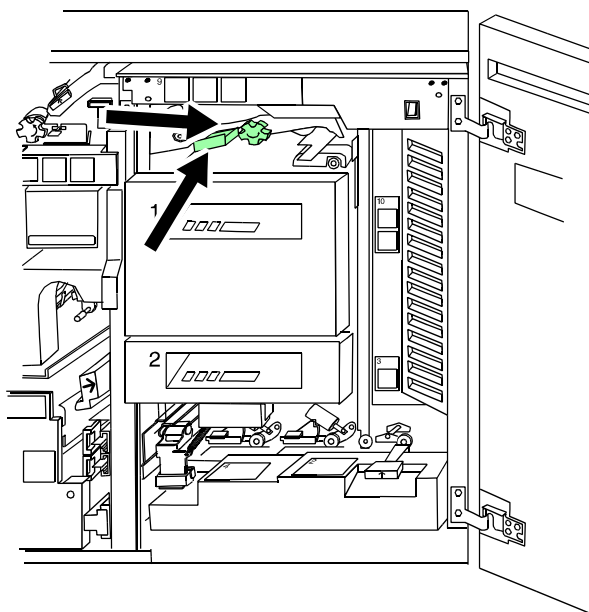
Figure 5-8 Area 7



**Figure 5-9 Area 8**



**NOTE:** *If a jammed sheet rips as you are removing it from area 8, you may have to use the pinch lever in area 9 to remove the paper. Refer to the “Note” following the area 14 figure for additional instructions.*



**Figure 5-10 Area 9**

To clear jams from area 9:

1. Lower and pull out tray 1 to give you better access to area 9.
2. Pull the area 9 green lever toward you to unlatch it. Be sure to relatch the lever after you have cleared any paper in this area. To further facilitate removing sheets wedged in this area, pull out tray 1 and hold the green lever down.
3. Turn the green knob (located to the right of the lever), to move jammed sheets further along the paper path to where they are more accessible and easier to remove.
4. If paper rips as you are removing it from area 9, or if you have difficulty removing paper from this area, use the pinch lever located further inside area 9. Paper may be caught in this area during duplex printing.

**Using the pinch lever to access area 9**

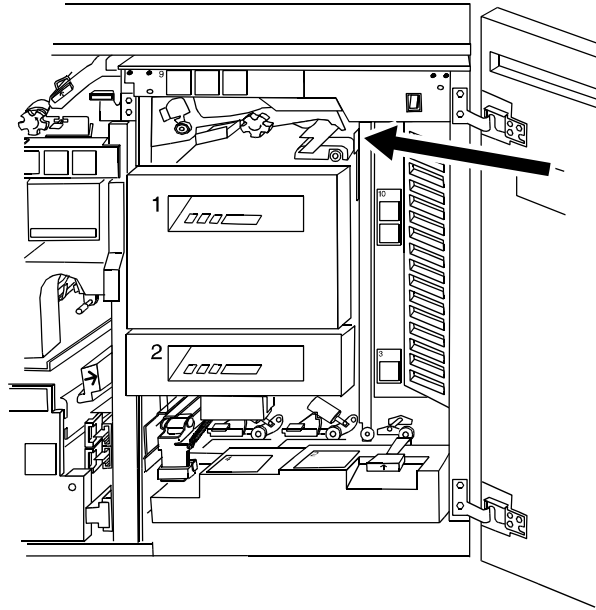
To use the pinch lever located inside area 9:



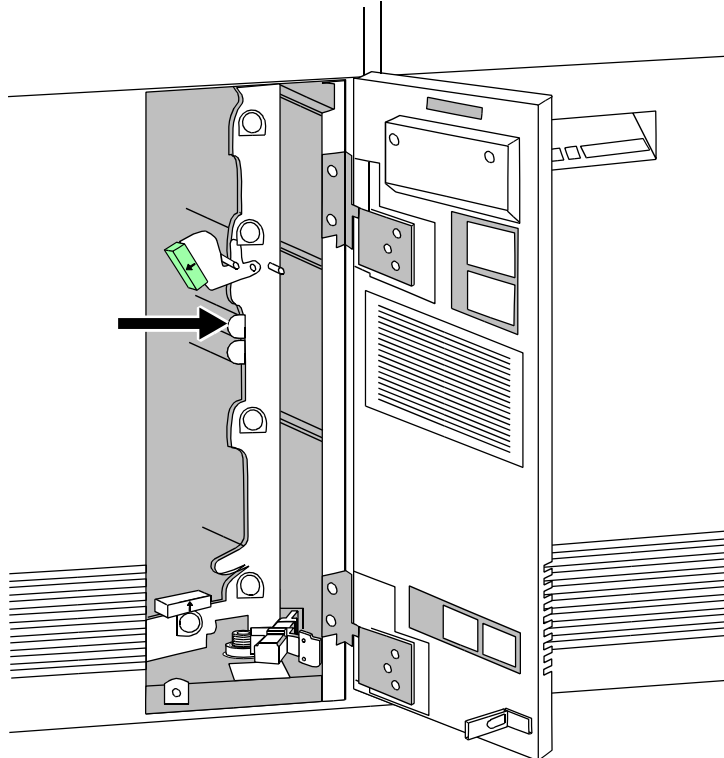
**CAUTION:** *This area of the printer may be hot. Be careful when inserting your hand.*

1. Locate the green pinch lever directly behind area 9 (above the green knob and further inside area 9).
2. Carefully reaching your hand into the area, squeeze the edges of the pinch lever and lift it up.
3. Remove any paper caught in this area.

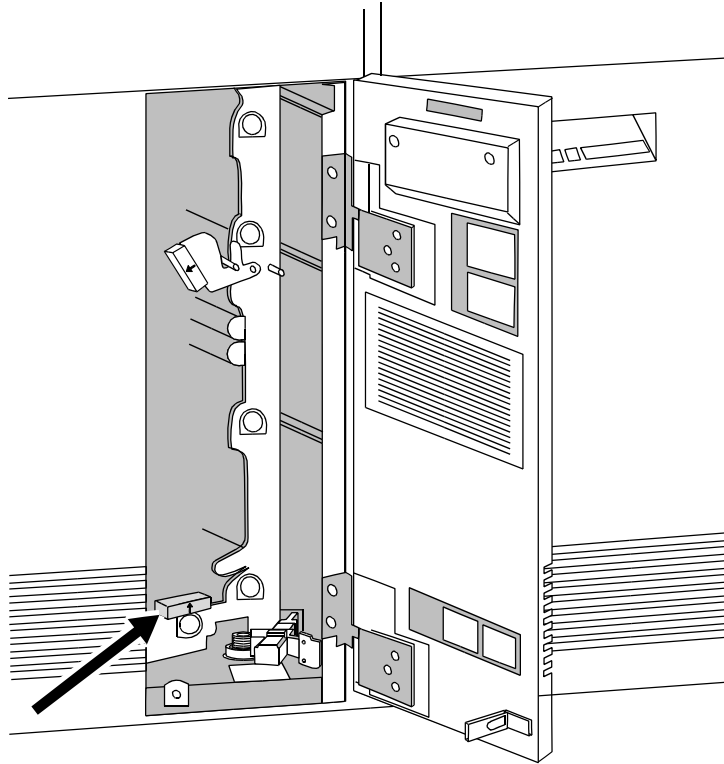
4. Turn the green pinch lever to its original position. Make sure that you relatch the lever after you have cleared any paper in this area.



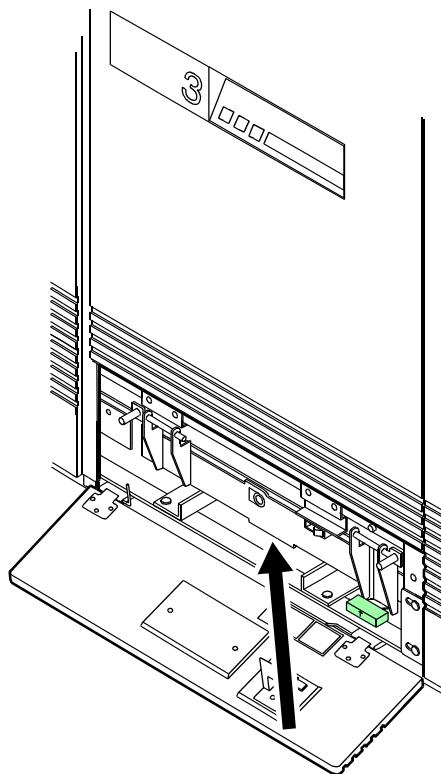
**Figure 5-11 Area 10**



**Figure 5-12 Area 11 (all feeder/stackers)**

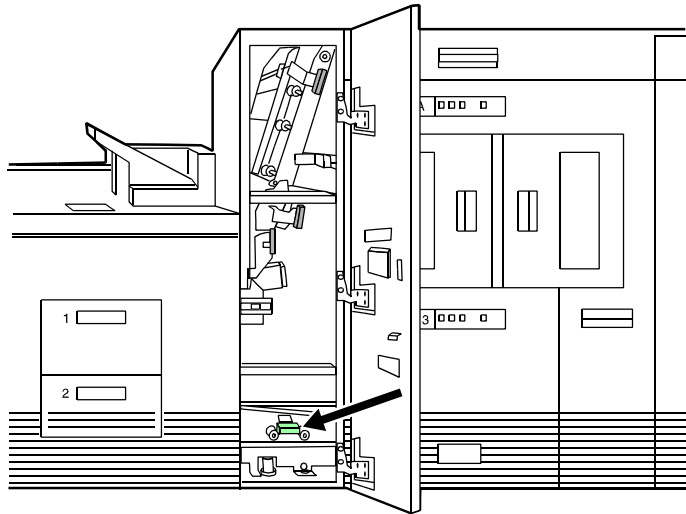


**Figure 5-13 Area 12 (all feeder/stackers)**



**Figure 5-14 Area 13**

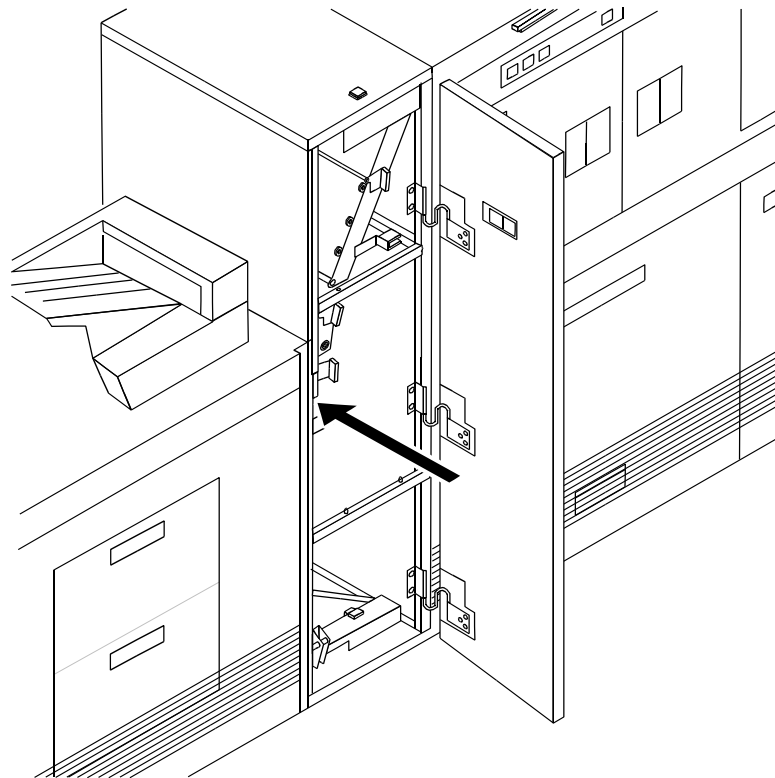




**Figure 5-15 Area 14**



**NOTE:** You may sometimes find paper lying on top of area 14, even though there is no message indicating a jam in this area. Discard the paper.



**Figure 5-16 Area 15**

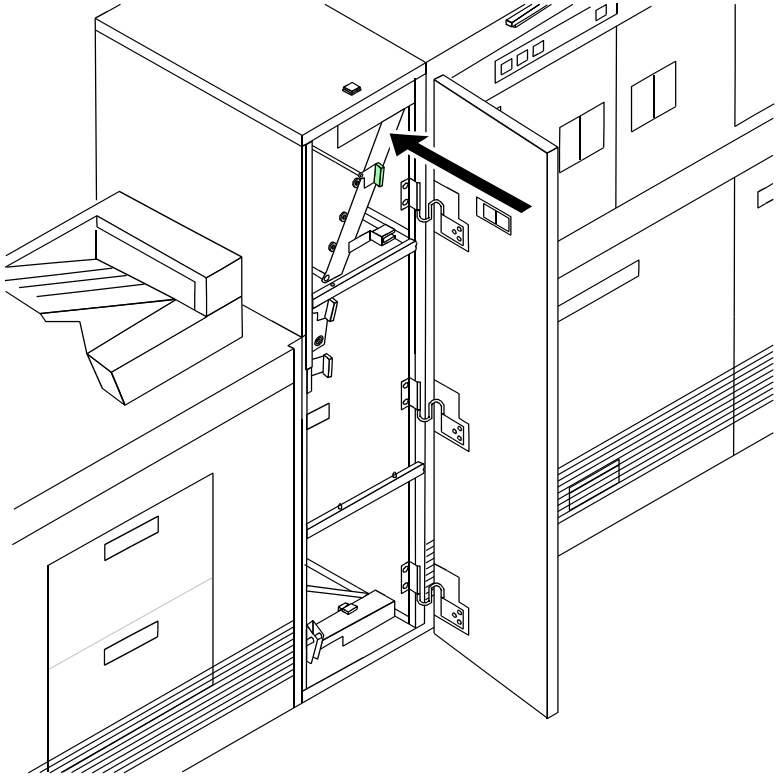


Figure 5-17 Area 16

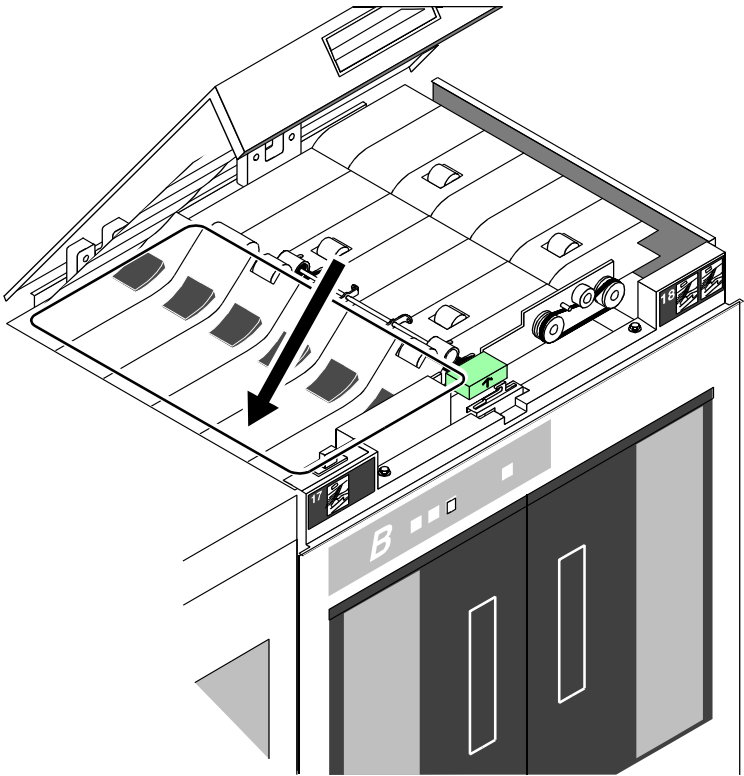
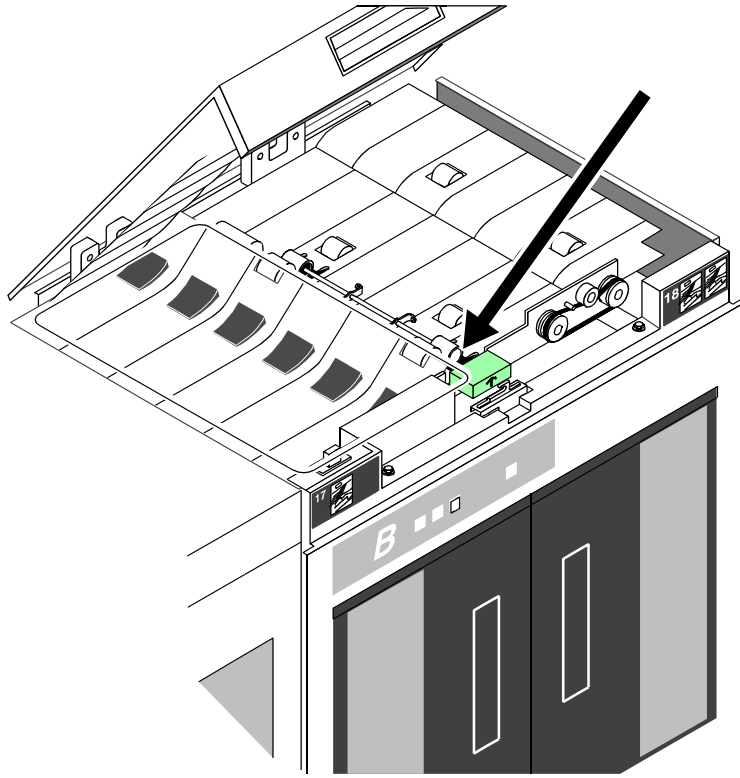


Figure 5-18 Area 17



**NOTE:** If your printer has frequent jams in this area, you may need to clean the Q1106 sensor.



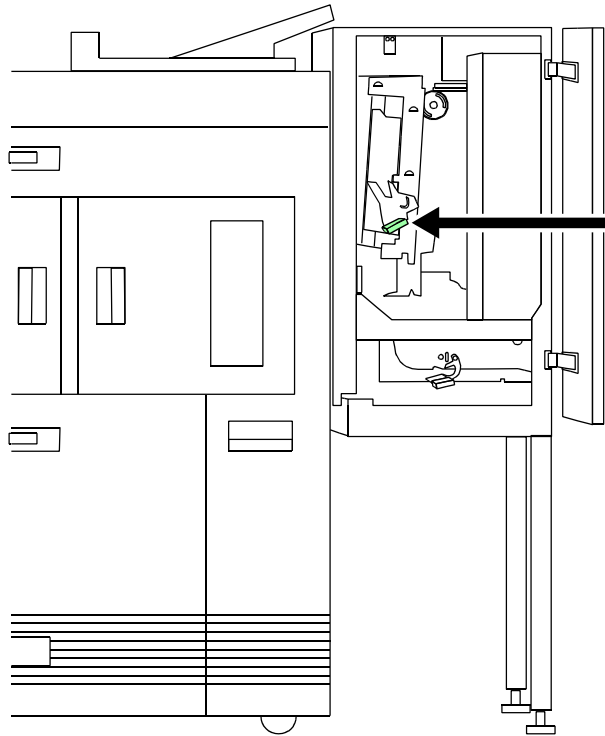
**Figure 5-19 Area 18**

Points to note for clearing jams in area 18:

- Sometimes the display monitor messages direct you to discard the last sheet delivered to the stack following a jam in area 18. Check for this message when clearing an area 18 paper jam.
- If your printer has frequent jams in this area, you may need to clean the Q1107 sensor.
- If your printer has a bypass transport module, you should check for paper jams in areas 19 and 20 after clearing an area 18 paper jam.

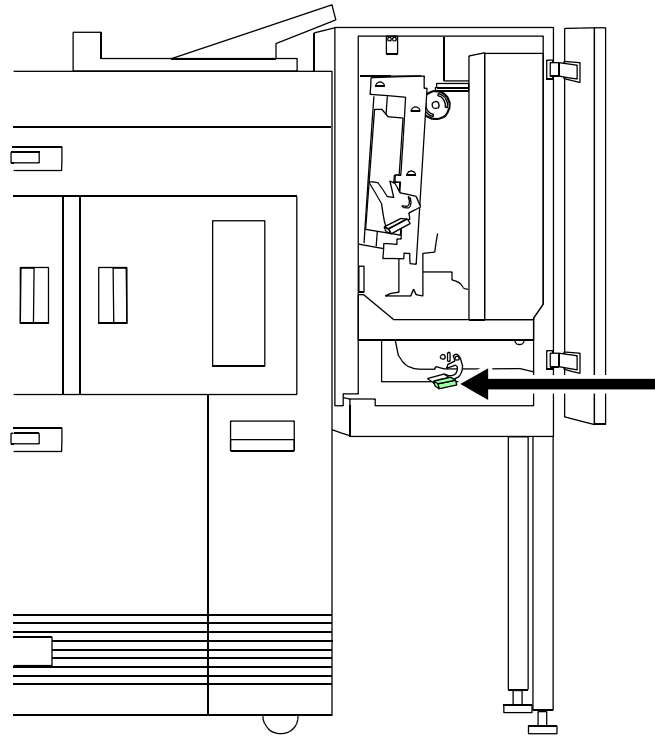
## Clearing a paper jam in the bypass transport

1. Open the bypass transport module door.
2. Press the area 19 green lever in the direction of the arrow printed on it.



**Figure 5-20 Press area 19 green lever**

3. Remove any paper from the exposed area.
4. Press the green lever to the left until the latch catches.
5. Press the area 20 green lever in the direction of the arrow printed on it.

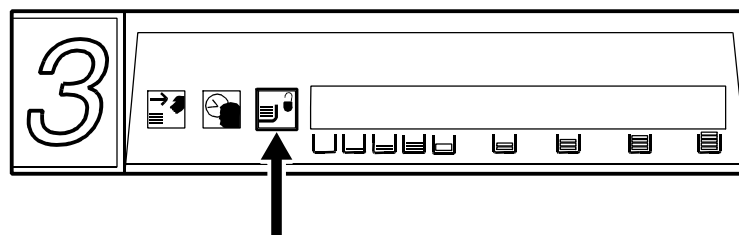


**Figure 5-21 Press area 20 green lever**

6. Remove any paper from the exposed area.
7. Press the green lever down and to the left until the latch catches.
8. Close the bypass transport module door.

### Clearing a misfeed (feeder tray fault)

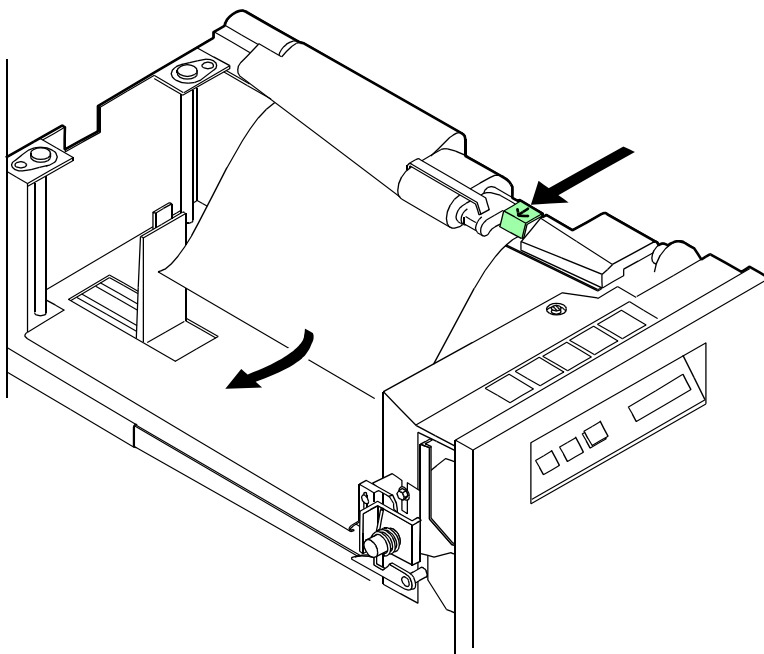
1. If the Ready to Open indicator is not lit, press the Tray Unlock button located on the feeder tray control panel.



**Figure 5-22 If necessary, press Tray Unlock button**

2. When the Ready to Open indicator lights, open the feeder tray. Pull the tray all the way out for best results.

3. For the processor feeder trays, press the green lever to unlatch the paper feeder assembly.



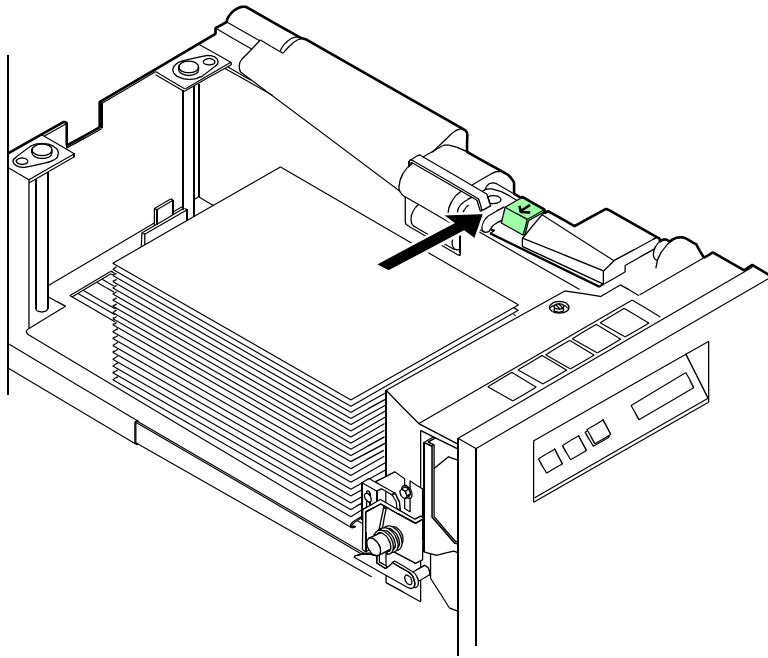
**Figure 5-23 Green lever to unlatch paper feeder assembly**

4. Remove and discard any partially fed paper. Ensure that:
  - The paper supply is neatly stacked.
  - The stack is not higher than the MAX line on the length guide.
  - The length guide is firmly touching the back edge of the stack.
  - For the high capacity feeder trays, also ensure the side guide is firmly touching the side of the stack.



**NOTE:** *You do not need to discard transparencies and other stiff materials unless they are damaged.*

5. For the processor feeder trays, relatch the paper feeder assembly by pressing the green dot until the assembly clicks into place.



**Figure 5-24 Relatch paper feeder assembly**

6. Slide the tray back into the printer until the tray latches and press the Continue button to resume printing.
7. Discard any pages sent to the sample tray, purge tray, or unused stacker bin when the misfeed was detected.

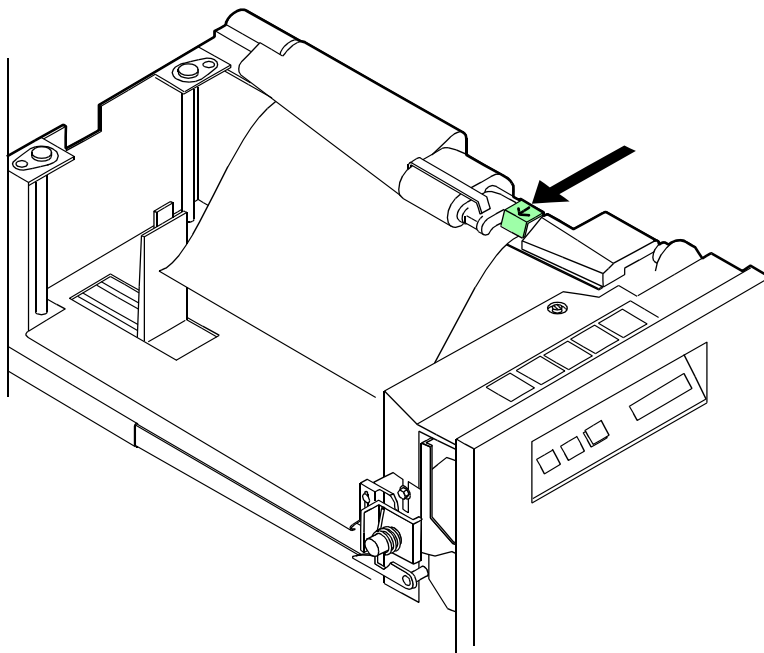
### **Troubleshooting frequent misfeeds (processor feeder trays)**

If the printer misfeeds frequently, the problem may be caused by a glazed feed belt, especially if you notice that one tray feeds the same paper better than another one does. (Glazing is caused by a buildup of the chemicals found on most papers.)

If you suspect this is the problem, cleaning the feed belt may eliminate the need to place a service call.

To clean the feed belt:

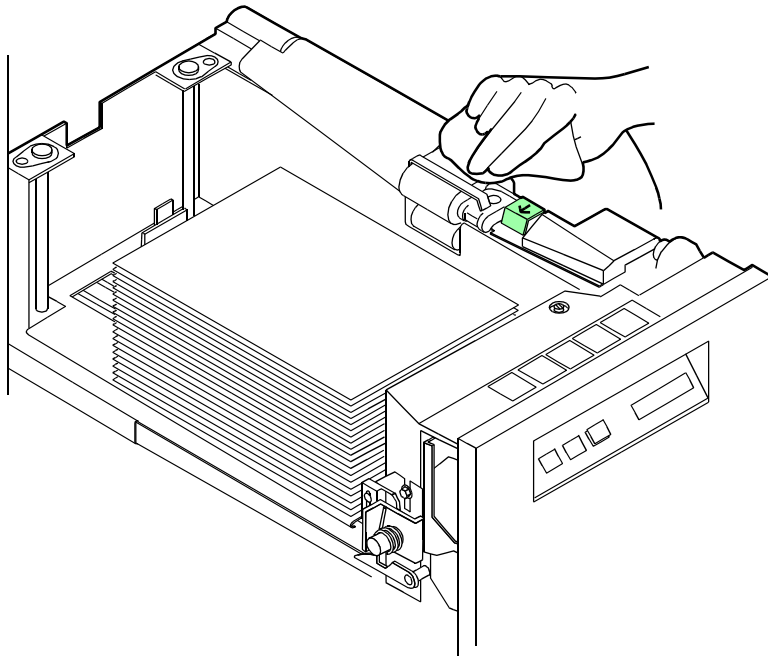
1. Clear any misfeeds that have occurred, but do not relatch the paper feeder assembly. The paper feeder assembly must be unlatched to clean the belt; if necessary, unlatch it by pressing down on the bright green lever on the right side of the paper tray.



**Figure 5-25** If necessary, unlatch paper feeder assembly

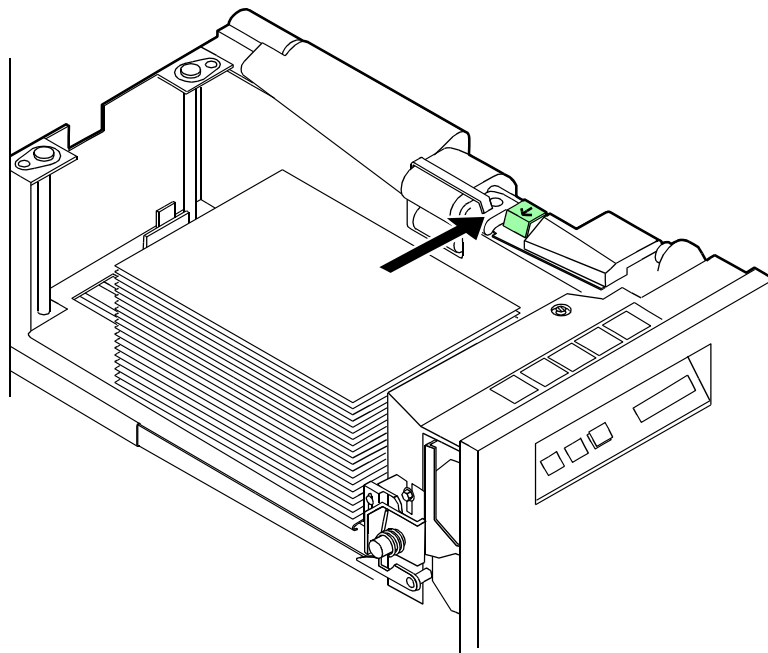
2. Lightly moisten a lint free towel with a Xerox recommended film remover and wipe the outside surface of the feed belt thoroughly in the same direction as the ribs on the belt. Wiping from side to side might pull the belt off its track. Allow a few seconds for the film remover to evaporate.





**Figure 5-26 Wipe outside surface of feed belt**

3. Relatch the paper feeder assembly by pressing down on the bright green dot. Slide the paper tray completely back into the printer.



**Figure 5-27 Press down on green dot to relatch paper feeder assembly**

4. Operate the system as usual. If you are still experiencing misfeeds, place a service call.



**NOTE:** *This procedure should be used only to correct a problem, not as a routine maintenance procedure. Because the belts are made of rubber, frequent cleaning with film remover dries them out and causes them to fail prematurely. Film remover may be obtained from your service representative.*

## Incorrect paper size message

---

Perform this procedure when printing stops and a incorrect paper size message appears on the display monitor.

1. Check the paper in the indicated tray. If the paper is not the correct size for the job, either load the correct size paper or select another feeder tray containing the correct size paper.
2. If the paper size is correct, select the Continue button to resume printing. The message may have been caused by a damaged sheet.



**NOTE:** *In order to assure good print quality for your jobs, the printer purges any dog-eared or skewed sheets. In addition, the printer may stop and issue an incorrect paper size message.*

## Generating a test page

---

You can print the sample test page on paper stock other than USLetter (8.5 by 11inches) or A4. While the PostScript test image does not cover the entire page when using non-USLetter or A4 sizes, you can still use the test page as a guide in making the necessary alignment adjustments. Fold the test page horizontally and vertically to check whether the folds intersect at the center of the page.

To change the alignment values:

1. Click the Queue Management icon.
2. Right click on the queue to which the job was sent, and select [**Properties...**] from the pop-up menu.
3. In the Properties window, select the [**Alignment**] tab.
4. Change the alignment values as needed.
5. Apply your changes by one of these methods:
  - Click [**Apply**] for the changes to go into effect on the next job.
  - Click [**Apply Properties Now**] to apply the changes to the current job. The system displays a message stating that the properties were changed and that it will take a little while to make the changes. The printer slows down or stops, then resumes printing. You can pause the printer at this point to check that your changes took affect.

---

## Troubleshooting stacker problems

---

The following stacker problems may occur during printing.

- **Problem:** Papers are being thrown around in the stacker.

This problem may occur when you have unloaded paper by opening the top cover of the stacker bin.



**NOTE:** *Do not open the top cover of the stacker bin to unload paper.*

To remedy this situation, unload the bin following the normal procedure.

- **Problem:** The paper stack is falling over or sliding around in the bin.

This problem may be due to excessive paper curl. Try the following:

- Reduce the paper curl by adjusting the decurler. Refer to the section, “Troubleshooting paper curl problems”.
- Reduce the number of sheets going to the bin.

---

## Troubleshooting paper curl problems

---

Too much curl in the paper stock can cause paper jams.

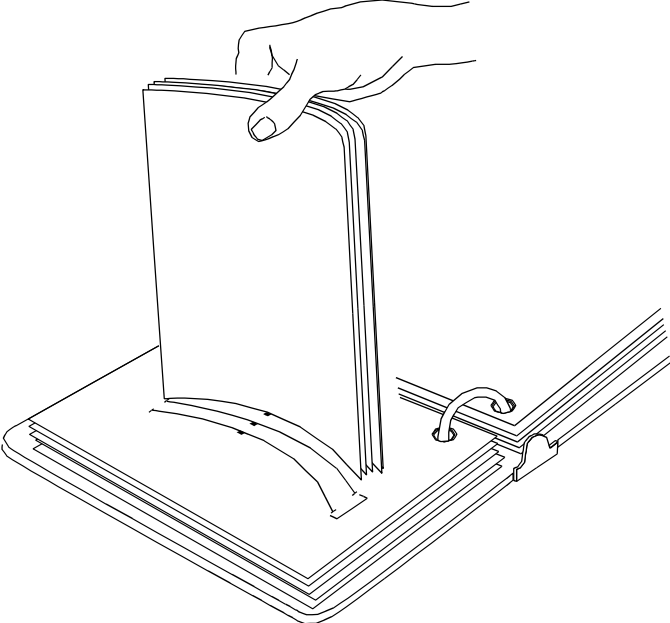
### Checking paper curl

---

You can adjust the decurler lever to correct most paper curl problems. Refer to the paper curl chart, later in this chapter, to determine the amount of curl in the paper stock.

Perform the following to measure paper curl:

1. Print five one sided (simplex) 8.5 by 11 inch or A4 sheets.
2. Hold the printed sheets by the top center of the short edge, keeping the image toward you.



**Figure 5-28** Hold printed sheets

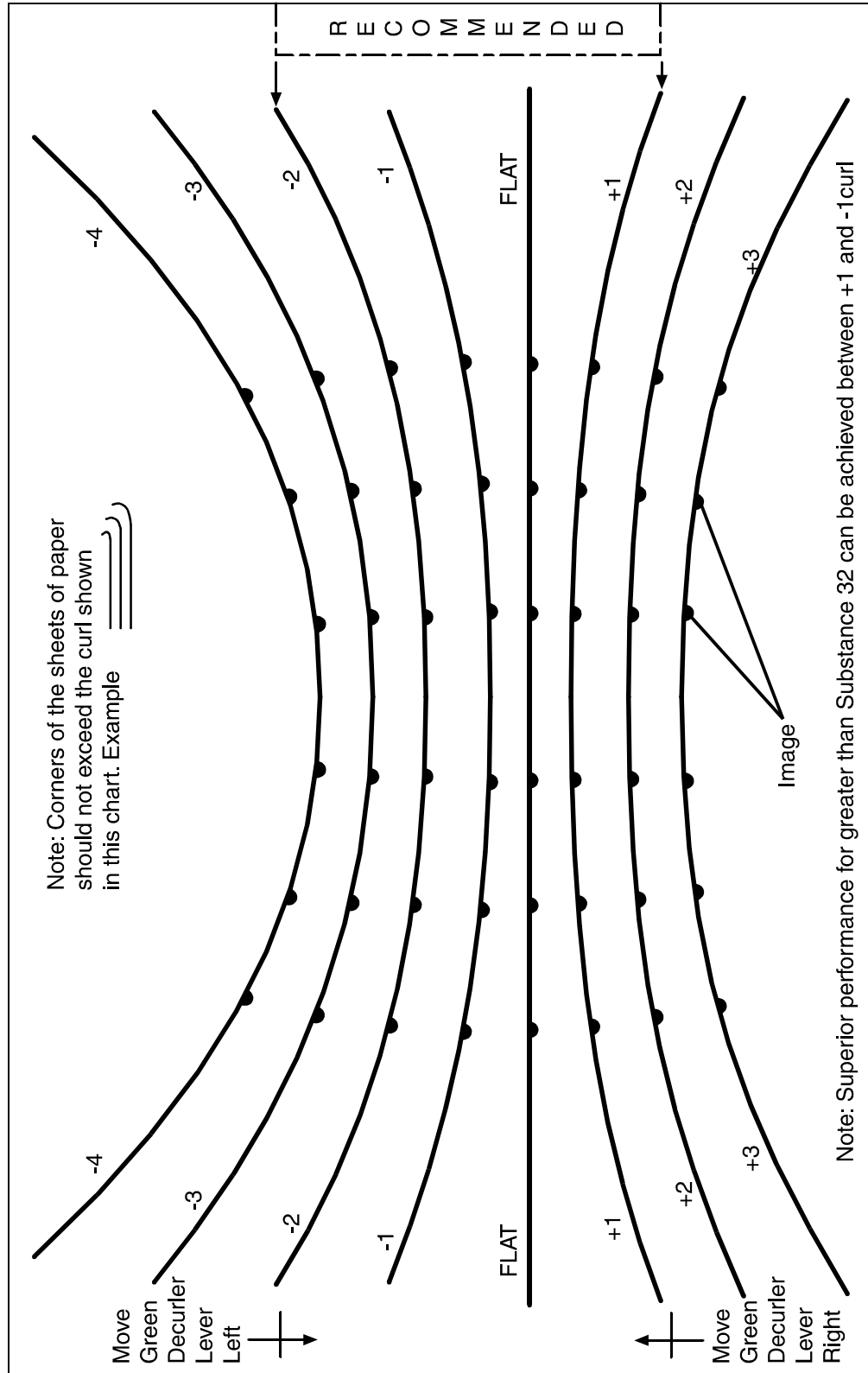


Figure 5-29 Paper curl chart

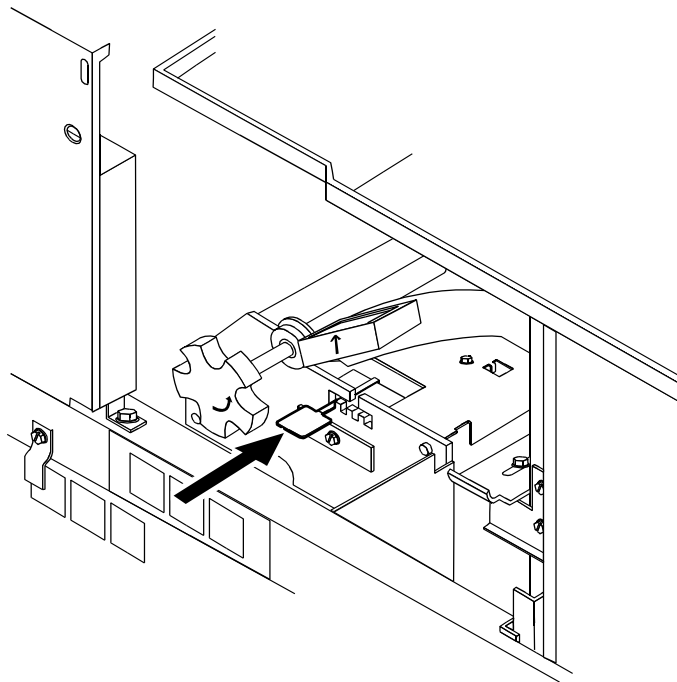
3. Place the bottom edge of the prints over the paper curl measurement chart on the line that best represents the curve of the sheets.
  - If the curl on the printed paper stock measures between +2 and -2, do not change the decurler setting.
  - If the curl is between +2 and +3, or -3 and -4, adjust the decurler lever.

## Adjusting the decurler lever

---

To adjust the decurler lever:

1. Open the right door of the printer and locate the decurler lever.



**Figure 5-30 Locate decurler lever**

2. If the print curl is +2 or more, move the green decurler lever to the right.
3. If the print is -3 or more, move the green decurler lever to the left.
4. If the decurler adjustment does not eliminate the paper curl problem, turn the paper stock over in the feeder tray.
5. If the curl problem persists, perform steps 1 to 4 again.
6. If the problem still persists, load paper from a new ream.

## Troubleshooting the 36-track tape drive

---

Use the following procedures to solve problems with your 36-track tape drive:

- Performing basic recovery
- Troubleshooting initial program load (IPL) failure
- Handling problems with inserting a tape cartridge
- Troubleshooting tape unload problem
- Unload a cartridge after a power failure
- Troubleshooting tape winding completely out of cartridge
- Troubleshooting blank message display
- Troubleshooting tape drive ready problem
- Calling for service

### Performing basic recovery

---

Always try to recover the cartridge from the inch cartridge tape drive before you try to correct any problems with the drive. Follow these basic recovery steps:

1. Take the tape drive offline.
2. If there is a relevant message on the display monitor or controller, perform the action described there.
3. If there is an error code on the tape drive message display, record the error code and time, then call for service.

### Troubleshooting initial program load (IPL) failure

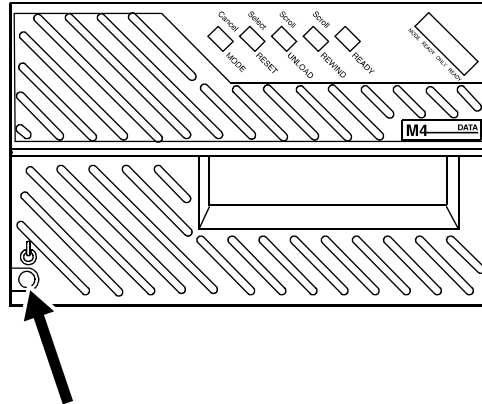
---

An error occurred during the IPL procedure if:

- The three indicator lights (Read only, Ready, and Mode) flash on the 36-track drive.
- An error code displays after you power on the tape drive.

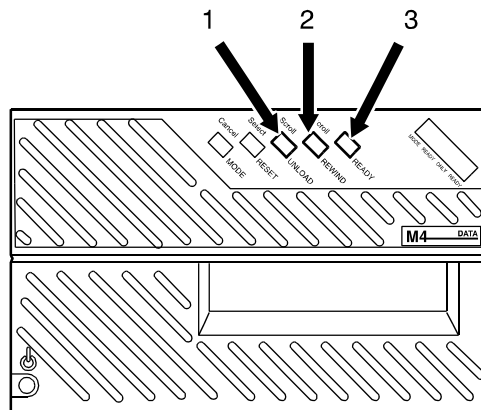
Perform IPL on the tape drive again, using one of the following procedure:

1. Turn off the tape drive by pressing the Power switch to OFF.
2. Wait 10 seconds and power the tape drive on by pressing the Power switch to ON.



**Figure 5-31 Power on tape drive**

3. For the 36-track drive, press and hold the Select, Scroll, and Ready buttons for at least five seconds.



**Figure 5-32 Press and hold Select, Scroll and Ready buttons**

1. **Select button**
2. **Scroll button**
3. **Ready button**

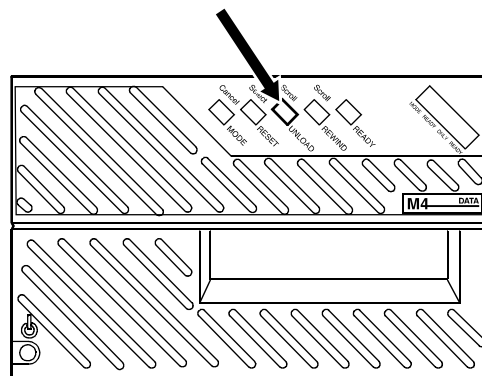
If the Initial Program Load procedure fails again, note the error code and time, then call for service.

## Solving other cartridge tape drive problems

Other problems that may occur with the 36-track cartridge tape drive include the following.



- **Problem:** The tape cartridge does not stay in place after insertion.  
Inspect the cartridge for damage.  
– If the cartridge is damaged, replace it.  
If the cartridge is undamaged, but the tape drive does not load it, call for service.
- **Problem:** The tape does not unload when the Unload button is pressed or [Unload] is selected on the Tape Client window.
  1. If there is an error code message on the message display, record the error code.
  2. Press the Unload button.



**Figure 5-33 Unload button**

3. Try unloading the tape again.
  4. If the tape still does not unload, record the error code on the message display, record the time, and call for service.
- **Problem:** Unloading a cartridge after a power failure
    1. Power on the tape drive.
    2. Press the Unload button.
  - **Problem:** The tape has wound completely out of cartridge  
Call for service. If there is an error code message on the message display, record the code and report it to the service representative.
  - **Problem:** The message display is blank.
    1. Ensure that the tape drive is receiving power from the main AC source.
    2. Ensure that the AC power switch on the rear of the tape drive is on.

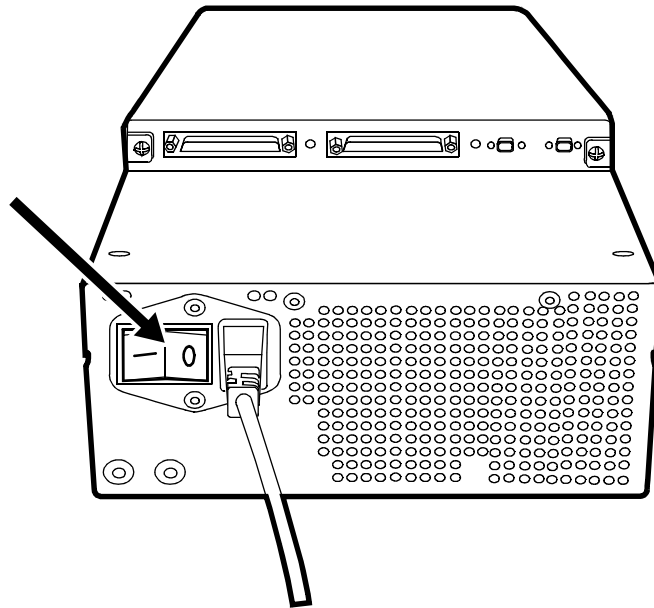


Figure 5-34 AC power switch

3. Turn the DC power switch OFF(0) and then ON (1).

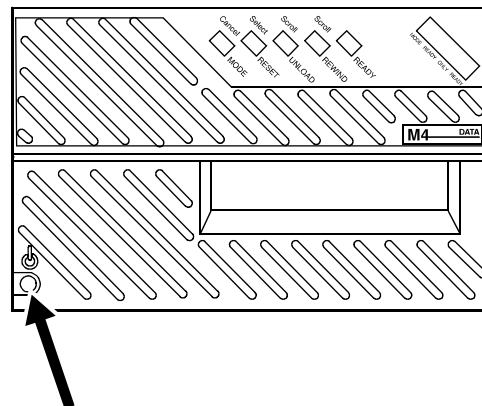
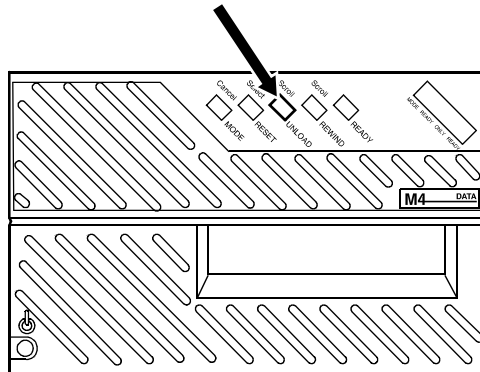


Figure 5-35 DC power switch

4. If the display is still blank, call for service.
- **Problem:** The tape drive does not go into a Ready state.
    1. Determine if the tape drive is online by pressing the Scroll button until the message display shows the Status display.
    2. If the tape drive is offline, refer to the section, “Placing the tape drive online” in the “Managing the system” chapter.
    3. If the tape drive still is not ready, the cartridge may be inserted incorrectly. Remove the cartridge from the transport and insert it again.

4. If there is an error code message in the message display, record the error code, press the Unload button, and try the operation again.



**Figure 5-36 Unload button**

5. If the tape drive still does not become ready, call for service. If there is an error code message on the message display, record the code and report it to the service representative.

## Calling for service

Before calling the Customer Service Support Center, ensure you have read this information and have tried the corrective actions described here. If the problem persists, gather the necessary information (details follow) and call the appropriate Customer Service Support Center phone number. Your site representative can supply you with the telephone number for the Customer Service Support Center in your area.

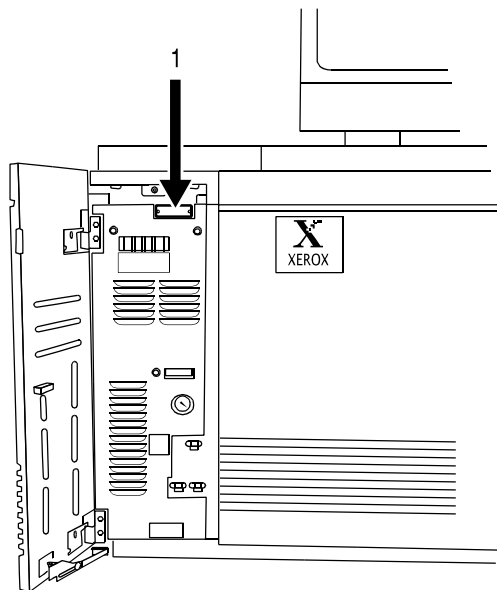
The correct phone number is attached to your printer at installation time.

Before calling for service, make note of:

- Print/job fault messages, that appear on the controller
- Status messages that appear on the display monitor
- Indicator lights that may or may not be lit
- Status codes that appear in the message display of the tape drive control panel if there is a tape drive problem

Your call is answered by a representative who asks you for your equipment model. You are also asked for:

- Your printing system serial number, which is located on a panel inside the printer, behind the small door on the left



**Figure 5-37** Location of printing system serial number indicated by label 1

- Your name
- Your company name
- The system condition or status



**NOTE:** *The printer serial number and fault codes can also be seen on the Tools display of the display monitor.*

This information is given to a customer service representative who calls you back to discuss the information and gives you an estimated time of arrival or assist you over the phone to resolve the problem.

# A Supplies

Effective management of your printing system requires that you maintain proper inventory levels of paper and other supplies at all times. No one wants to lose production time because supplies are not available when they are needed.

Planning ahead also makes sense from a financial standpoint. It allows you to take advantage of quantity discounts, which can mean very great savings to your company. Your sales representative or supply specialist can help you plan most effectively and economically. The purpose of this information is to give you a summary of the most used paper and the necessary supplies, their order numbers, and how to order them from Xerox.

## Available supplies

---

The table lists the supplies that are available from Xerox for your laser printing system. Use this table to help you determine your supply needs.

**Table A-1 Supplies**

Item	Description	Supply Number
<b>Paper</b>	Xerox paper quantities are 10 reams (5000 sheets) to a carton unless otherwise noted. The 3, 4, and 7 hole papers marked with an asterisk (*) are drilled with 5/16 inch holes.	
8.5 x 11 inch	4024 Dual Purpose Paper	3R721
A4	4024 Dual Purpose Paper	3R2594
8.5 x 14 inch	4024 Dual Purpose Paper	3R727
8.5 x 11 inch	4024 Dual Purpose Paper 3 hole	3R723
8.5 x 11 inch	4024 Dual Purpose Paper 3 hole*	3R2193
8.5 x 11 inch	4024 Dual Purpose Paper 4 hole	3R1983
8.5 x 11 inch	4024 Dual Purpose Paper 4 hole*	3R3008
8.5 x 11 inch	4024 Dual Purpose Paper 7 hole	3R1984
8.5 x 11 inch	4024 Dual Purpose Paper 7 hole*	3R3010
8.5 x 11 inch	4024 Smooth	3R2675
8.5 x 14 inch	4024 Smooth	3R2677
8.5 x 11 inch	Dual Purpose Colors, Blue	3R3052

Item	Description	Supply Number
8.5 x 11 inch	Dual Purpose Colors, Blue, 3 hole	3R3068
8.5 x 14 inch	Dual Purpose Colors, Blue	3R3084
8.5 x 11 inch	Dual Purpose Colors, Green	3R3056
8.5 x 11 inch	Dual Purpose Colors, Green, 3 hole	3R3072
8.5 x 14 inch	Dual Purpose Colors, Green	3R3088
8.5 x 11 inch	Dual Purpose Colors, Pink	3R3058
8.5 x 11 inch	Dual Purpose Colors, Pink, 3 hole	3R3074
8.5 x 14 inch	Dual Purpose Colors, Pink	3R3090
8.5 x 11 inch	Dual Purpose Colors, Yellow	3R3054
8.5 x 11 inch	Dual Purpose Colors, Yellow, 3 hole	3R3070
8.5 x 14 inch	Dual Purpose Colors, Yellow	3R3086
8.5 x 11 inch	Dual Purpose Colors, Buff	3R3060
8.5 x 11 inch	Dual Purpose Colors, Buff, 3 hole	3R3076
8.5 x 14 inch	Dual Purpose Colors, Buff	3R3092
8.5 x 11 inch	Dual Purpose Colors, Goldenrod	3R3062
8.5 x 11 inch	Dual Purpose Colors, Goldenrod, 3 hole	3R3078
8.5 x 14 inch	Dual Purpose Colors, Goldenrod	3R3094
8.5 x 11 inch	Dual Purpose Colors, Ivory	3R3064
8.5 x 11 inch	Dual Purpose Colors, Ivory, 3 hole	3R3080
8.5 x 14 inch	Dual Purpose Colors, Ivory	3R3096
8.5 x 11 inch	Dual Purpose Colors, Gray	3R3066
8.5 x 11 inch	Dual Purpose Colors, Gray, 3 hole	3R3802
8.5 x 14 inch	Dual Purpose Colors, Gray	3R3098
8.5 x 11 inch	Dual Purpose Colors, Rainbow Pack (35,000 sheets /carton, 250 sheets/pack)	3R3107
8.5 x 11 inch	10 Series Dual Purpose Paper	3R2950
8.5 x 11 inch	10 Series Dual Purpose Paper, 3 hole	3R2952
8.5 x 11 inch	10 Series Dual Purpose Paper, 3 hole*	3R3016
8.5 x 14 inch	10 Series Dual Purpose Paper	3R2954
8.5 x 11 inch	10 Series Smooth	3R54
8.5 x 14 inch	10 Series Smooth	3R83
8.5 x 11 inch	4024 Dual Purpose, reinforced 3 hole	3R2057
9 x 11 inch	65 lbs, divider white	3R3428
11 x 17 inch	4024 Dual Purpose Paper	3R729
<b>Transparencies</b>	Xerox transparencies are packaged 100 to a box	

Item	Description	Supply Number
8.5 x 11 inch	Clear, with a white strip on the edge	3R2780
<b>High speed labels (gummed)</b>	All labels are on 8.5 x 11 inch sheets, 1000 sheets to a box.	
8.5 x 11 inch	33 labels per sheet	3R3139
8.5 x 11 inch	24 labels per sheet	3R4474
8.5 x 11 inch	8 labels per sheet	3R4475
8.5 x 11 inch	6 labels per sheet	3R3146
8.5 x 11 inch	1 label per sheet	3R4476
8.5 x 11 inch	Custom form To order call the appropriate telephone number in your area.	
<b>Tab stock</b>	250 sheets per carton	
Straight Collated Singles (5 tab set)	Non-drilled, 90 lbs, Index white	3R4417
	3 hole drilled, 90 lbs, Index white	3R4418
	Non-drilled, 90 lbs, Index blue	3R4425
	3 hole drilled, 90 lbs, Index blue	3R4426
Reverse Collated Singles (5 tab set)	Non-drilled, 90 lbs, Index white	3R4415
	3 hole drilled, 90 lbs, Index white	3R4416

Item	Description	Supply Number
<b>Cover stock</b>		
8.5 x 11 inch	65 lbs, blue	3R3044
8.5 x 11 inch	65 lbs, white	3R3041
<b>Dry ink</b>	Packaged 3 cartridges per carton. (Consumption rate is approximately 180,000 pages per carton for 8.5 x 11 inch paper at 7% coverage.)	6R206
<b>Dry ink, MICR</b>	Packaged 3 cartridges per carton. Consumption rate is approximately one cartridge per 60,000 pages.	6R819
<b>Dry ink waste bottle</b>		93K460
<b>Developer</b>	Packaged 2 bottles per carton. Effective life is approximately 1,000,000 pages per carton. (2 bottles required for replacement.)	5R161
<b>Developer, MICR</b>	Packaged 2 bottles per carton. Effective life is approximately one carton per 600,000 pages. (2 bottles required for replacement.)	5R573
<b>Fuser agent</b>	Packaged 1 bottle per carton. (Consumption rate is approximately 250,000 pages per liter.)	8R2955
<b>Cleaning supplies</b>	1/2 inch cleaning cartridge. Call the appropriate telephone number in your area to order.	8R3635
	QIC Tape Drive Head Cleaning Kit	9R88432
	Foam-tipped swabs	99P87256
	Lint free towels	35P2163
	Hub and Transport Cleaner	99P87486
<b>Containers</b>		
8.5 x 11 inch	Base	9R1103
	Pallet	9R1104
11 x 17 inch	Base	9R1105
	Pallet	9R1106
<b>QIC blank cartridge</b>	150 MB blank cartridge tape	9R84168
	8 GB blank cartridge tape	109R00510



## How to order supplies

---

---

Call the appropriate telephone number in your area to order supplies. Your site representative can supply you with the telephone number for ordering supplies in your area.

Give the representative the following information:

- Your Xerox customer number (which is supplied by your Xerox representative). Your customer number is also included on your Xerox invoice.
- Your equipment model number: DocuPrint 180 EPS, for example
- Item description (Refer to “Available supplies,” earlier in this chapter.)
- Quantities required for each item
- A purchase order number, if that is the method of payment used by your company



# Index

## Numerics

---

- 18/36-track tape drive
  - cleaning 15
  - loading tape 9
  - troubleshooting 41
- 26-track tape drive 29
  - cleaning 15
- 36-track tape drive 29
- 7 x 10 enablement kit 18
- 9-track tape drive 30

## A

---

- ASCII jobs 7
- Attention light 11

## B

---

- back panel, controller 25
- bins, output 12
- bypass transport 16
  - clearing paper jams 29
  - paper paths 20

## C

---

- cartridge tape drives
  - 26-track 29
  - 36-track 29
- CD-ROM drive
  - see DVD-ROM drive
- CE mark viii
- cleaning
  - 18/36-track tape drive 15
  - 26-track tape drive 15
  - diskette drive 16
  - display 22
  - DVD drive 16
  - exterior surfaces 22
  - reflecting surfaces 16
  - sensors 16
  - system 14
- client problems
  - troubleshooting 2

- components
  - controller 21–27
    - Sun Blade 1000/2000 21
    - Sun Blade 2500 23–24
    - Sun W1100z 23–24
  - printer 10–14
- conditioning paper 3
- connectivity, host 2
- consumables 4
- controller
  - components 21–27
    - Sun Blade 1000/2000 21
    - Sun Blade 2500 23–24
    - Sun W1100z 23–24
  - moving 27
  - options 26
  - overview 20
  - stand 26
- conventions xi
- curl, paper 3
- custom transfer assist blade 13

## D

---

- data formats 3
- decurler lever, adjusting 40
- DFA support 17
- DigiPath 2
- disk drive, controller 24
- diskette drive
  - cleaning 16
- diskette drive, controller 24
- Document Feeding and Finishing Architecture,
  - see DFA
- documentation
  - available xiii
- DocuSP Print Services 1
- dry ink cartridge, replacing 11
- dry ink waste container, replacing 7
- DVD drive
  - cleaning 16
- DVD-ROM drive, controller 24–25

## E

---

emergency power off  
system 5

## F

---

feeder/stacker 11  
feeders, support and interface 17  
file protection 12  
floppy drive  
    see diskette drive  
font problems 4  
functional overview 1  
fuser agent, adding 4

## G

---

graphical user interface  
    problems 2  
GUI, see graphical user interface

## H

---

HCF, see high-capacity feeder  
HCSF, see high-capacity stacker  
Help documentation, printing 13  
high-capacity feeder 14, 15  
high-capacity stacker 14  
host connectivity 2

## I

---

inverter feeder/stacker 14  
IPL procedure 41

## J

---

job flow 6  
job integrity 17  
    troubleshooting 5

## L

---

laser safety v  
loading  
    tape 9  
long and short edge feeding 31

## M

---

misfeed, clearing 31  
monitor, controller 26  
moving the controller 27

## O

---

offline interface 27  
online and offline interfaces 26  
online interface 26  
operation safety, Europe vi–viii  
operation safety, U. S. vi  
options  
    printer 16  
ordering supplies 5  
output bins 12  
overview  
    controller 20  
    functional 1  
    printer 8  
ozone production information v

## P

---

paper  
    care 1  
    characteristics 5  
    conditioning 3  
    curl 3  
    size 4  
    size and pitch mode 33–37  
    sizing and print speed 30  
    specifications 3  
    storing 1  
    supported stocks 5  
    width and throughput speed (LCDS) 31–33  
paper curl, problems 37  
paper jams  
    clearing 15  
    clearing, all areas 16  
    clearing, areas 2 through 20 18  
    clearing, bypass transport 29  
paper levers, adjusting 2  
paper paths 18  
    bypass transport 20

- printer 18
- paper size, incorrect 36
- PCL jobs 7
- PCL problems 6
- PDF jobs 7
- PDF problems 8
- PDL problems 6
- performance, troubleshooting 9
- peripheral cabinet 30
- pinch lever 24
- pitch mode 33–37
- PostScript jobs 7
- PostScript problems 6
- print quality, problems 3
- print speed 30
- printer
  - components 10–14
  - controlling 1
  - heavy paper levers, adjusting 2
  - high capacity output bins 12
  - options 16
  - overview 8
  - paper paths 18
  - print volume 9
  - throughput speeds 8
  - trays 11
- Printer control console 15, 1
- printer controller, *see* controller
- printing process 6
- printing speed 8
- problems
  - DigiPath 2
  - font 4
  - graphical user interface 2
  - print quality 3
- problems, classifications 1
- processor feeder trays 10
- processor, controller 24
  - external components 26
  - optional components 26
- productivity, troubleshooting 9
- protection, files 12
- publications
  - available xiii
- purge tray 11

---

## S

---

- safety
  - hotline numbers vi
  - laser v
  - operation vi–viii
- sample tray 10
- saving jobs, troubleshooting 10
- sensors
  - cleaning 16
- service, calling for 45
- short edge feeding 31
- shutdown, system 3
- speed, print 30
- speed, printing 8
- stacker problems, troubleshooting 37
- stand, controller 26
- stock
  - size 4
  - specifications 3
  - supported 5
- Sun Blade
  - 1000/2000
    - components 21
  - 2500
    - components 23
- Sun W1100z 21
  - components 23
- supplies 1
  - ordering 5
- system
  - cleaning 14
  - emergency power off 5
  - powering down 4
  - powering off 4
  - shutdown 3
  - starting, stopping, rebooting 1

---

## T

---

- tape drive
  - 26-track 29
- tape drives 29–30
  - 26-track 29
  - 36-track 29
  - 9-track reel 30

- peripheral cabinet 30
- tape, loading 9
- The 1
- throughput speed 30
- TIFF jobs 7
- TIFF problems 7
- trays 11
  - 1 and 2 10
  - processor, feeder 10
  - purge 11
  - sample 10
- troubleshooting
  - 36-track tape drive 41
  - client problems 2
  - frequent misfeeds 33
  - job integrity 5
  - paper curl problems 37
  - PDL problems 6
  - process problems 8
  - productivity and performance 9
  - saving jobs 10
  - stacker problems 37
  - undeclared faults 1

## V

---

- vent locations
  - controller
    - Sun Blade 1000/2000 27
    - Sun Blade 2500 28
    - Sun W1100z 28

## Free Manuals Download Website

<http://myh66.com>

<http://usermanuals.us>

<http://www.somanuals.com>

<http://www.4manuals.cc>

<http://www.manual-lib.com>

<http://www.404manual.com>

<http://www.luxmanual.com>

<http://aubethermostatmanual.com>

Golf course search by state

<http://golfingnear.com>

Email search by domain

<http://emailbydomain.com>

Auto manuals search

<http://auto.somanuals.com>

TV manuals search

<http://tv.somanuals.com>