

Thank you for purchasing this Factory Service Manual CD/DVD from servicemanuals4u.com.

Please check out our eBay auctions for more great deals on Factory Service Manuals:

servicemanuals4u

Notice

The information in this guide is subject to change without notice.

Compaq Computer Corporation shall not be liable for technical or editorial errors or omissions contained herein; nor for incidental or consequential damages resulting from the furnishing, performance, or use of this material.

This guide contains information protected by copyright. No part of this guide may be photocopied or reproduced in any form without prior written consent from Compaq Computer Corporation.

Copyright 1994, 1995 Compaq Computer Corporation.
All rights reserved. Printed in the U.S.A.

Compaq, Deskpro, LTE, Contura, Presario, ProLinea
Registered U. S. Patent and Trademark Office.

The software described in this guide is furnished under a license agreement or nondisclosure agreement. The software may be used or copied only in accordance with the terms of the agreement.

Product names mentioned herein may be trademarks and/or registered trademarks of their respective companies.

MAINTENANCE AND SERVICE GUIDE
COMPAQ CONTURA 400 FAMILY OF PERSONAL COMPUTERS

Second Edition (June 1995)
First Edition (September 1994)
Part Number 147951-002

- o Compaq Service Quick Reference Guide
- o Service Training Guides
- o Compaq Service Advisories and Bulletins
- o Compaq QuickFind

Chapter 1. Illustrated Parts Catalog

Introduction

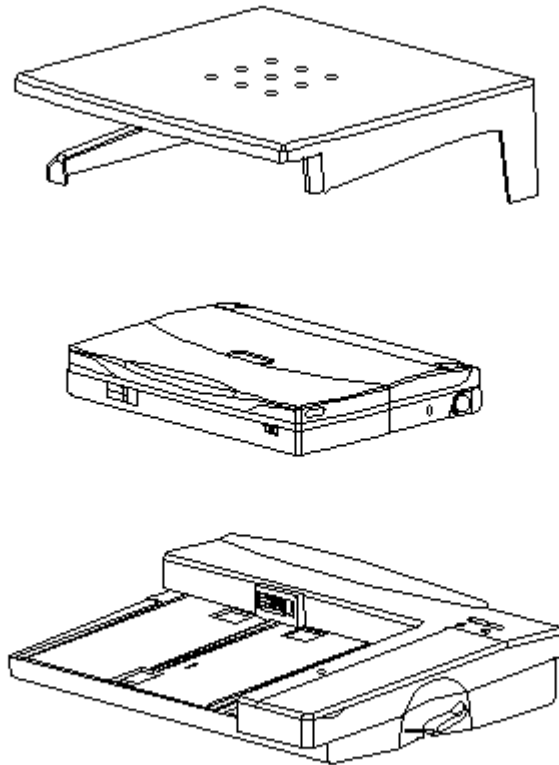

Figure 1-1. Compaq Contura 400 Personal Computer with Docking Base and Monitor Support Cover (All Models)

Chapter 1.1 Illustrated Parts Breakdown

The computer combines a display assembly and system unit module. The display and system unit module are joined together by clutches on either side secured by screws in the chassis and display enclosure allowing it to open and close. The system unit module is secured to the CPU base by screw locks in the rear and screws in the bottom of the system unit enclosure. The display assembly is secured by screws installed in the front bezel of the display enclosure.

This chapter provides a description of the system unit module, display assembly, docking base, and monitor support cover. It includes a complete parts breakdown.

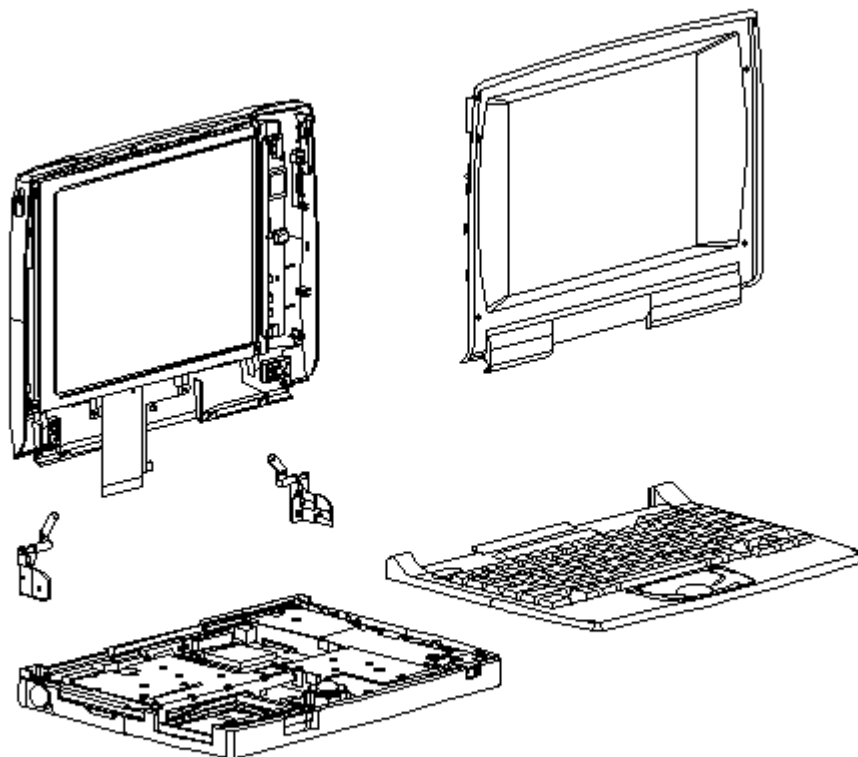

Figure 1-2. Display Assembly, Keyboard Assembly, and CPU Base (All Models)

Chapter 1.2 Serial Number

The computer serial numbers should be provided to Compaq whenever requesting information or ordering spare parts. The serial number is located on the bottom of the computer.

The serial number on the Docking Base is located on the rear of the base.

Chapter 1.3 System Unit Module Overview

The system unit module (Figure 1-4) contains the following upgradable components:

- o Hard drive
- o Memory expansion board
- o Processor upgrade (Contura 400 only)

A complete list of replaceable parts is included in Table 1-1. Major components include:

- o Battery pack and compartment components
- o Keyboard assembly
- o Integrated trackball assembly
- o Diskette drive
- o System board
- o PC Card (PCMCIA) ejector rails and components

The hard drive, memory expansion board, and battery pack are accessed from the bottom of the computer. To service the remaining system unit module components, the keyboard assembly must be removed. Most major components connect directly to the system board by connectors. The only cables in this unit are the display assembly cable, the display ground cable, and diskette drive cable.

Compaq Contura Models

Table 1-1 lists the Compaq Contura 400 Family of Personal Computer Models and standard features.

Table 1-1. Compaq Contura 400 Family of Personal Computer Models

Model	Processor	Hard Drive	Memory	Display
Contura 400	486 DX2/40 MHz	170 MB	4 MB	9.5 in Monochrome
Contura 400	486 DX2/40 MHz	250 MB	4 MB	9.5 in Monochrome
Contura 400C	486 DX2/40 MHz	250 MB	4 MB	9.5 in Color STN
Contura 400CX	486 DX2/40 MHz	250 MB	4 MB	8.4 in. Color TFT
Contura 410	486 DX2/50 MHz	250 MB	4 MB	9.5 in Monochrome
Contura 410C	486 DX2/50 MHz	250 MB	4 MB	9.5 in Color STN
Contura 410C	486 DX2/50 MHz	350 MB	4 MB	9.5 in Color STN
Contura 410CX	486 DX2/50 MHz	350 MB	4 MB	8.4 in. Color TFT
Contura 420C	486 DX4/75 MHz	350 MB	4 MB	10.4 in. Color STN
Contura 420C	486 DX4/75 MHz	420 MB	8 MB	10.4 in. Color STN
Contura 420CX	486 DX4/75 MHz	420 MB	8 MB	10.4 in. Color TFT
Contura 430C	486 DX4/100 MHz	420 MB	8 MB	10.4 in. Color STN
Contura 430C	486 DX4/100 MHz	720 MB	8 MB	10.4 in. Color STN
Contura 430CX	486 DX4/100 MHz	720 MB	8 MB	10.4 in. Color TFT

Note: Processor, hard drive and memory upgrades are available for most models

Models 400 and 410

This section provides a description of the system unit module components for Models 400 and 410. These components are accessed from the bottom of the computer:

- o Hard drive -- The hard drive is easily replaced or upgraded from the bottom of the computer. Remove two screws from the hard drive compartment cover to access the hard drive. The hard drive mounts to the system chassis with a hard drive bracket and connects directly to the system board with no intervening cables. The hard drive bracket attaches to the hard drive with four screws.
- o Memory expansion -- System memory can be upgraded with optional memory expansion boards. An expansion board is added or replaced from the bottom of the computer through the memory compartment cover. The memory expansion board connects directly to the system board with two connectors.
- o Battery pack -- The Nickel Metal Hydride battery pack is accessed through the battery compartment.

To access the remaining system unit components, open the computer and remove the keyboard assembly. These components include the following:

- o Integrated trackball assembly -- The mechanical trackball is centrally located at the bottom of the keyboard assembly. The assembly consists of the trackball, retaining ring, and connector. The trackball assembly connects directly to the system board and is secured by one screw. It cannot be replaced with the optical trackball used in the Models 420 and 430. The mechanical trackball and optical trackball are not interchangeable.
- o System board -- The system board is mounted directly to the system chassis. All removable components connected to the system board, except for the PC Card rails, must be removed prior to removing the system board. The system board is unique and cannot be replaced by the one used in the Models 420 and 430.
- o Processor upgrade -- Systems that come with the DX2/40 MHz processor can be upgraded to the DX2/50 MHz processor. Place the upgrade processor into the two connectors on the system board (Refer to "Removal and Replacement Procedures, Section 3.11). Once installed, the processor overrides control of the system board processor. The system board processor is not removable.
- o Real-Time Clock Battery -- This battery is located directly behind the Trackball.
- o PC Card rails -- The PC Card rails are replaceable and are secured by two screws from the bottom of the system board and a clip on top of the rails. The rails are not interchangeable with those used in Models 420 and 430. The clip is common between all models. The header attaches directly to the system board and cannot be removed. The top and bottom

PC Card ejection levers are replaceable, but are not interchangeable with those used in the Models 420 and 430.

- o Diskette drive -- The diskette drive attaches to the system board by a bracket and three screws. It is connected by a diskette drive cable and LIF connector. The bracket attaches to the drive with four screws. The drive is protected by an insulator between the system board and the drive.

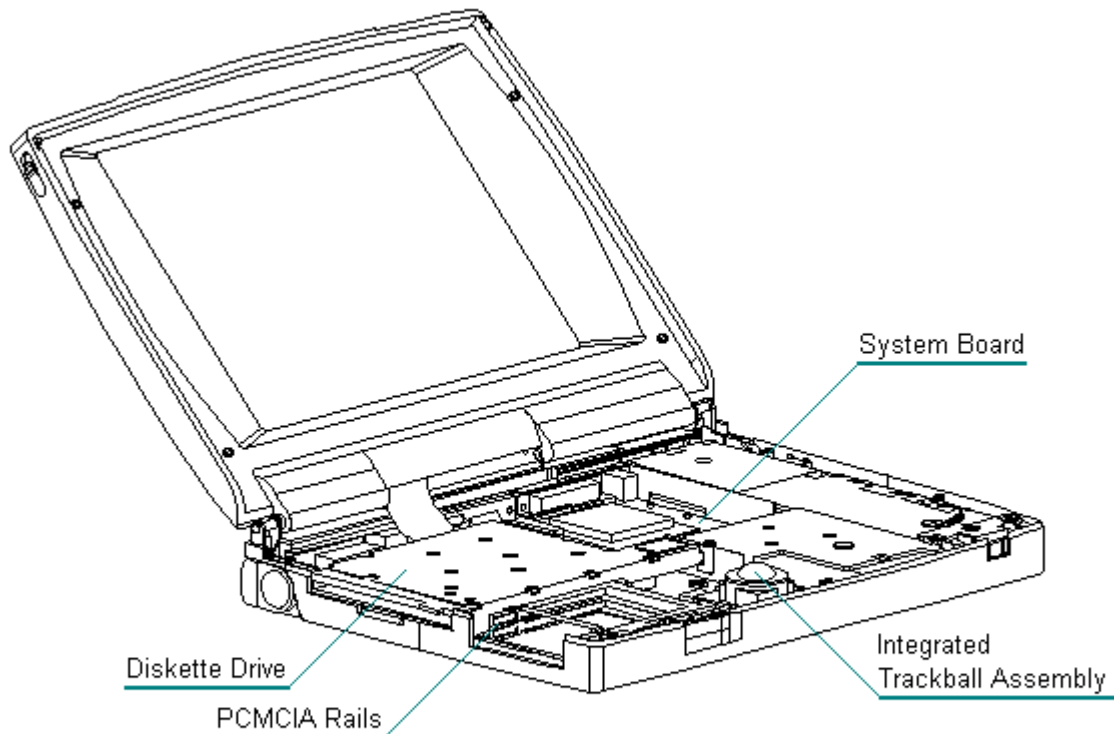

Figure 1-3. System Unit Module for Models 400 and 410

Models 420 and 430

This section provides a description of the system unit module components for Models 420 and 430. These components are accessed from the bottom of the computer:

- o Hard drive -- The hard drive is easily replaced or upgraded from the bottom of the computer. Remove two screws from the hard drive compartment cover to access the hard drive. The hard drive mounts to the system chassis with a hard drive bracket and connects directly to the system board with no intervening cables. The hard drive bracket attaches to the hard drive with four screws.
- o Memory expansion -- System memory can be upgraded with optional memory expansion boards. An expansion board is added or replaced from the bottom of the computer through the memory compartment cover. The memory expansion board connects directly to the system board with two connectors.

- o Battery pack -- The Nickel Metal Hydride battery pack is accessed through the battery compartment.

To access the remaining system unit components, open the computer and remove the keyboard assembly. These components include the following:

- o Integrated trackball assembly -- This optical trackball is centrally located at the bottom of the keyboard assembly. The assembly consists of the trackball, retaining ring, and connector. The trackball assembly connects directly to the system board and is secured by two screws. It cannot be replaced with the mechanical trackball used in the Compaq Models 400 and 410. The optical trackball and mechanical trackball are not interchangeable among computer models.
- o System board -- The system board is mounted directly to the system chassis. All removable components connected to the system board, except for the PC Card rails, must be removed prior to removing the system board. The system board is unique and cannot be replaced by the one used in the Compaq Models 400 and 410.
- o Processor upgrade -- Models 420 and 430 are equipped with either a DX4/75 MHz or a DX4/100 MHz processor on the system board. There are no upgrade provisions for these models.
- o Real-Time Clock Battery -- This battery is located in the left rear area of the system board.
- o PC Card rails -- The PC Card rails are replaceable and are secured by two screws from the bottom of the system board and a clip on top of the rails. The rails are not interchangeable with those used in Models 420 and 430. The clip is common between all models. The header attaches directly to the system board and cannot be removed. The top and bottom PC Card ejection levers are replaceable, but are not interchangeable with those used in the Models 400 and 410.
- o Diskette drive -- The diskette drive attaches to the system board by a bracket and three screws. It is connected by a diskette drive cable and LIF connector. The bracket attaches to the drive with four screws. The drive is protected by an insulator between the system board and the drive.

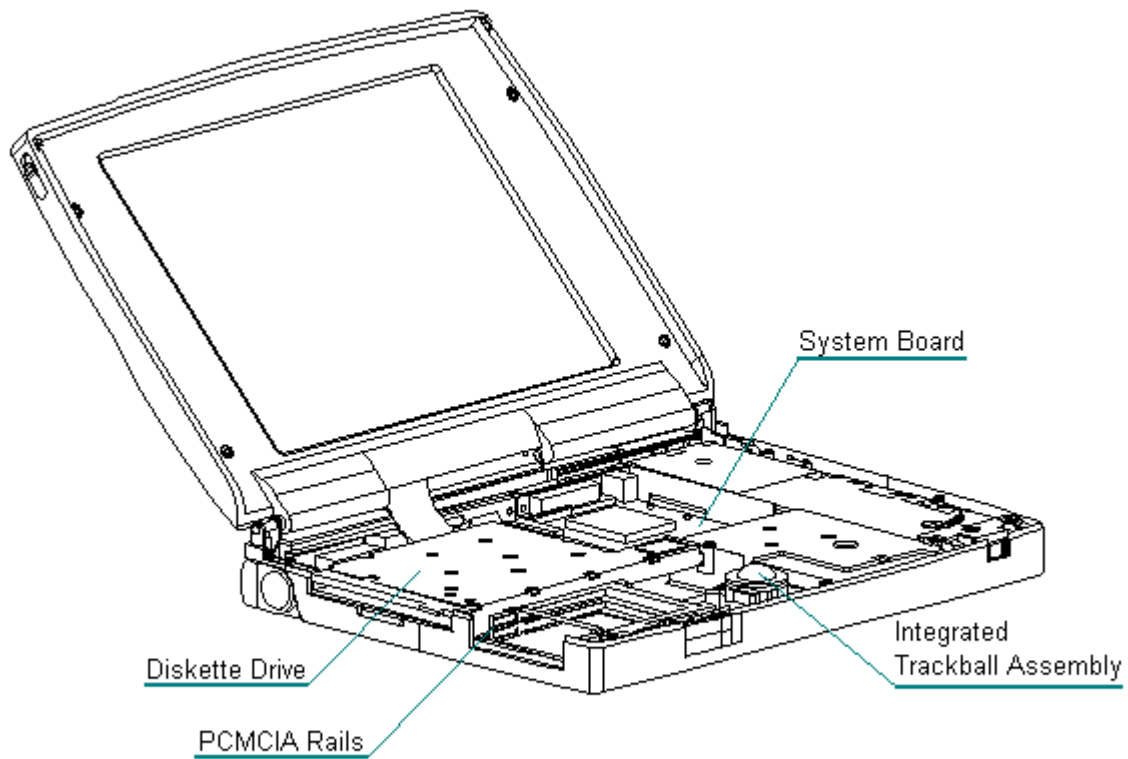

Figure 1-4. System Unit Module for Models 420 and 430

Chapter 1.4 Display Assembly Overview

Display Assembly Description

This section provides a description of the display assembly and components.

All display assemblies (Figure 1-5 and Figure 1-6) include the following replaceable parts:

- o Bezel
- o Enclosure latches
- o Inverter board
- o Liquid crystal display (LCD) panel
- o Shield
- o Enclosure
- o Display cable and display ground cable

To replace the display assembly, the assembly must be removed from the system unit module. This is done by removing the keyboard assembly, disconnecting the display cable and display ground cable from the system unit module, removing the tilt feet and handle brackets, removing the rear clutch screws, and lifting off the display assembly.

To service display components, do not remove the display assembly from the system unit module (unless the display enclosure or clutch replacement is required). Access display components (inverter board or latches) by removing the bezel secured with four screws on the front of the display.

The display cable is a prefolded, flex cable that connects to the display inverter board with a low insertion force (LIF) connector. The other end of the display cable is exposed at the bottom of the display enclosure and connects to the system board with a zero insertion force (ZIF) slide connector.

The display ground cable connects to the display shield on one end, and the other end clips to a LIF-type spring clip located above the serial port between the system board and system chassis.

The display inverter board is aligned to the right of the display enclosure with pins. One end connects to the display cable; the other end connects to the backlight cable of the LCD panel.

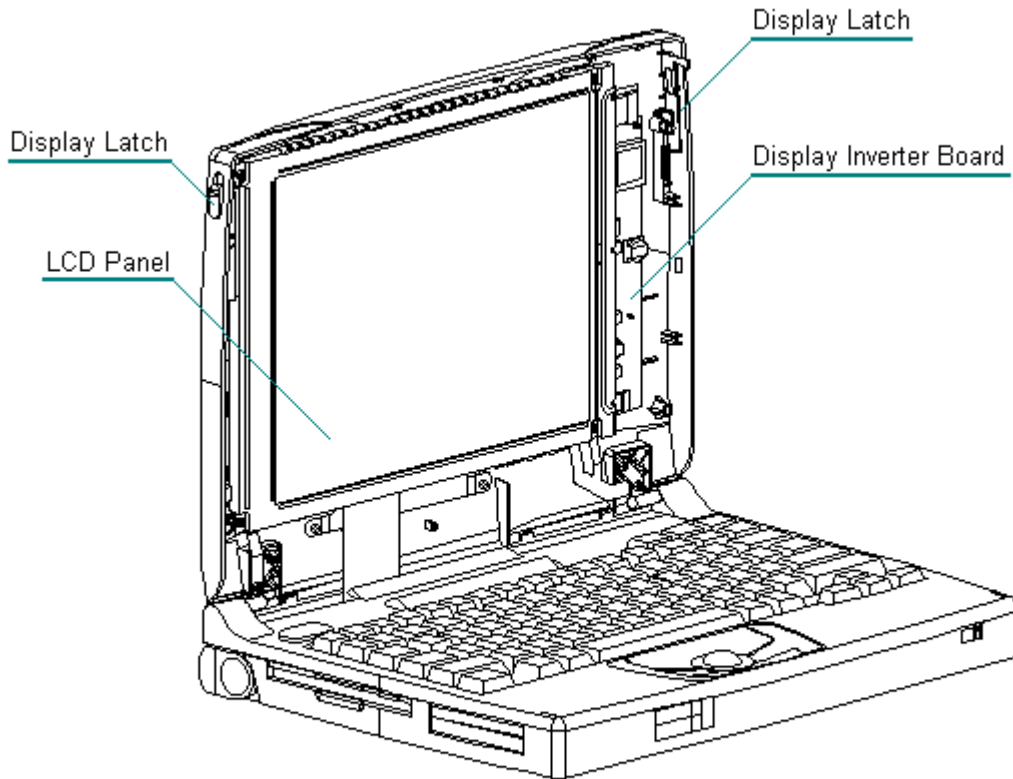

Figure 1-5. Display Assembly for Models 400 and 410

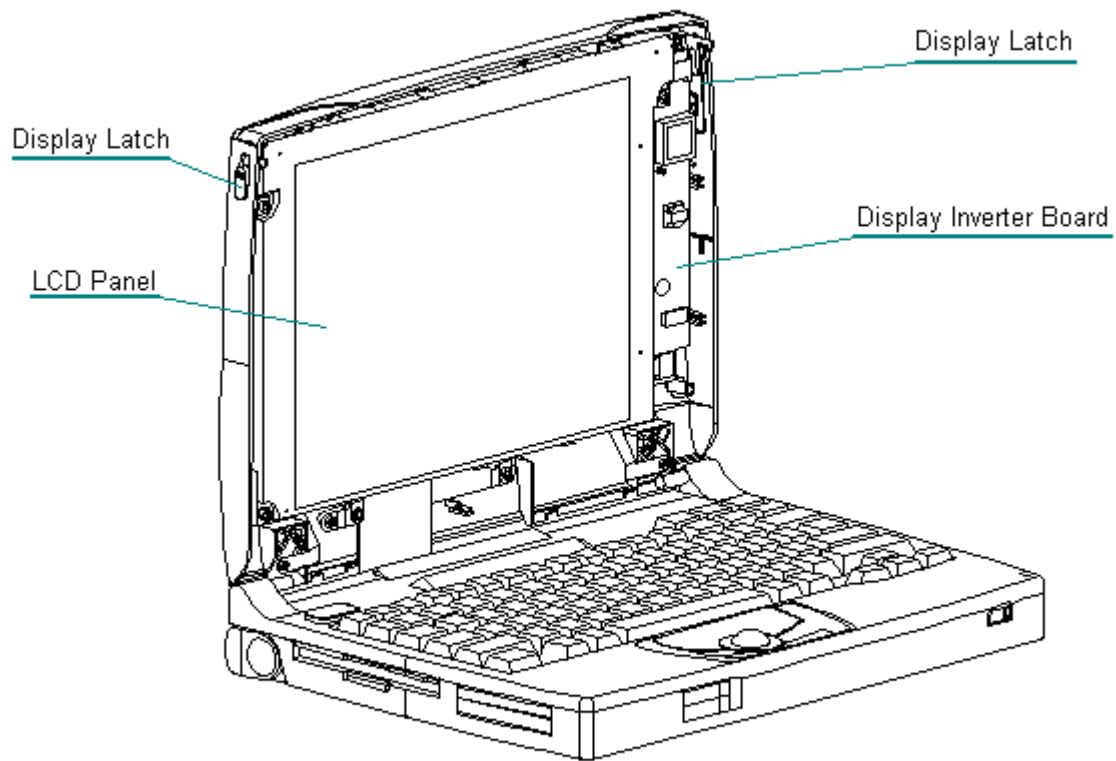

Figure 1-6. Display Assembly for Models 420 and 430

Chapter 1.5 Docking Base

The docking base includes the following replaceable parts:

- o Battery door
- o Feet
- o Handle

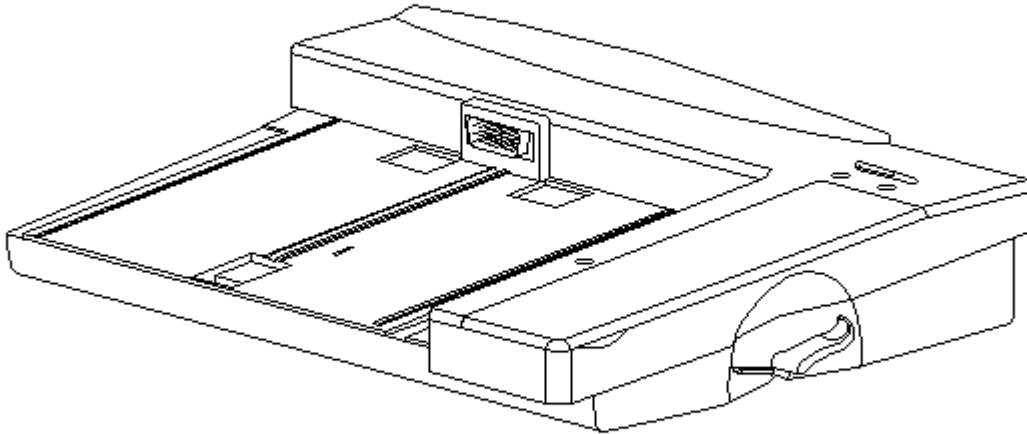

Figure 1-7. Docking Base (All Models)

Chapter 1.6 Monitor Support Cover

The monitor support cover is used with the docking base. The foot on the monitor support cover is the only replaceable part.

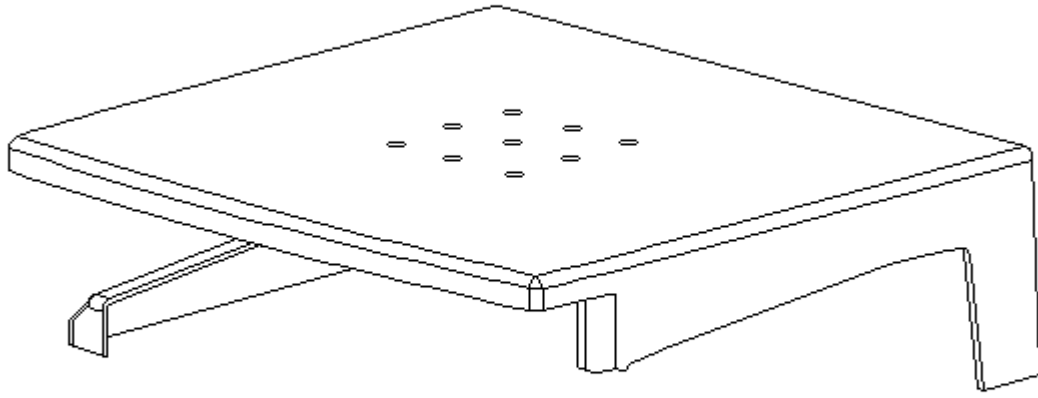

Figure 1-8. Monitor Support for All Models

Chapter 1.7 System Unit Module Parts

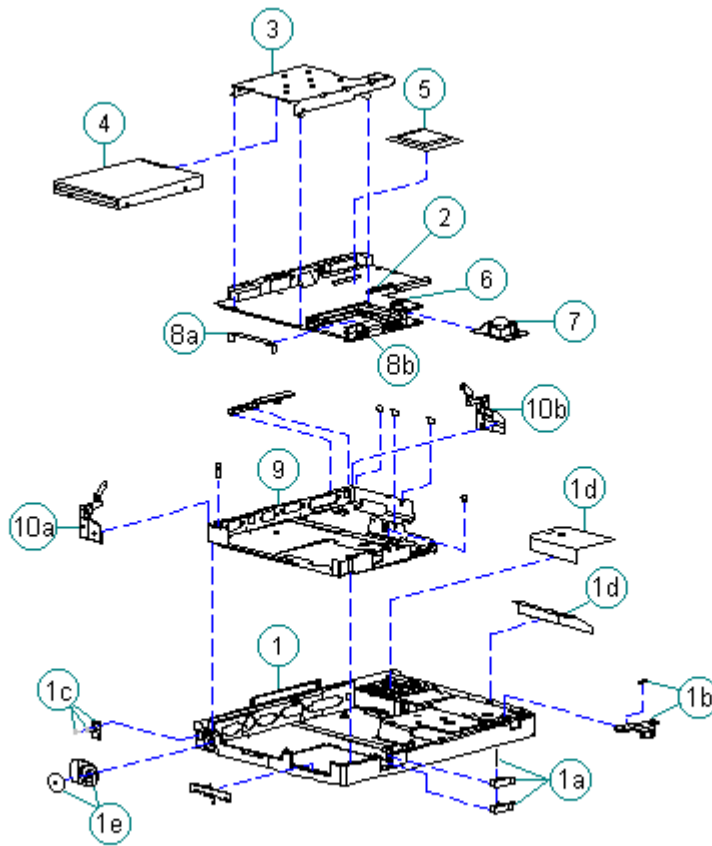

Figure 1-9. System Unit Module Parts for Models 400 and 410

Table 1-2. System Unit Module -- Models 400 and 410

Description	Spare Part Number	Notes
1. Base enclosure	147856-001	Includes: a. PC Card eject levers, pin, door, and spring b. battery latch button and spring c. handle bracket, screws and washers d. battery shield, insulator e. tilt foot and screws f. warning label * g. anti-skid pads * h. memory door *
2. System board		Include PC Card ejector rails, hard drive insulators, and gasket.
- 486 DX2/40 MHz	147944-001	
- 486 DX2/50 MHz	147621-001	
3. Diskette drive bracket	147857-001	
4. Diskette drive	147963-001	

5. Processor upgrade 486 DX2/50 MHz	169644-001	
6. Real-time clock battery	117099-001	
7. Mechanical Trackball	147876-001	
8. PC Card ejection assembly	147871-001	Includes the following and screws *. a. rails b. clip c. screws *
9. Chassis	147865-001	
10. Clutches	147858-002	Includes: a. left b. right
11. Hard drive *		
- 350 MB	189111-001	Does not include hard drive bracket.
- 250 MB	199233-001	
- 170 MB	169685-001	
12. Hard drive bracket *	147872-001	
13. Memory expansion board *		
- 4 MB	147654-001	
- 8 MB	147656-001	
- 16 MB	147658-001	
- 24 MB	189261-001	
14. NiMH battery pack *	190626-001	
15. Screws kit *	147885-001	

* Not Shown

=====

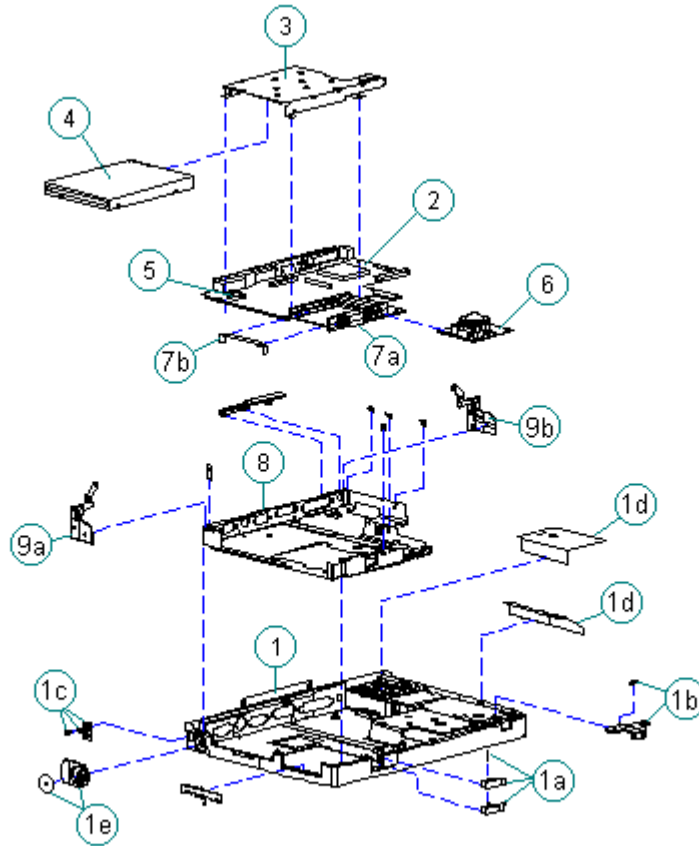

Figure 1-10. System Unit Module Parts for Models 420 and 430

Table 1-3. System Unit Module -- Models 420 and 430

Description	Spare Part Number	Notes
1. Base enclosure	189239-001	Includes: a. PC Card eject levers, pin, door, and spring b. battery latch button and spring c. handle bracket, screws and washers d. battery shield, insulator e. tilt foot and screws f. warning label * g. anti-skid pads * h. memory door *
2. System board		Includes PC Card ejector rails, hard drive insulators, and gasket
- 486 DX4/75 MHz 4 MB	189115-001	
- 486 DX4/75 MHz 8 MB	189116-001	
- 486 DX4/100 MHz 8 MB	189134-001	

3. Diskette drive bracket	189240-001	
4. Diskette drive	147963-001	
5. Real-time clock battery	117099-001	
6. Optical Trackball assembly	189197-001	
7. PC Card ejection assembly	189242-001	Includes the following and screws *. a. rails b. clip c. screws *
8. Chassis	189241-001	
9. Clutches	147858-001	Includes: a. left b. right
10. Hard drive *		Does not include hard drive bracket.
- 720 MB	189156-001	
- 540 MB	189132-001	
- 420 MB	189112-001	
- 350 MB	189111-001	
11. Hard drive bracket *	147872-001	
12. Memory expansion board *		
- 4 MB	147654-001	
- 8 MB	147656-001	
- 16 MB	147658-001	
- 24 MB	189261-001	
13. NiMH battery pack *	190626-001	
14. Screws kit *	147885-001	
* Not Shown		

Chapter 1.8 Monochrome Display Assembly Parts

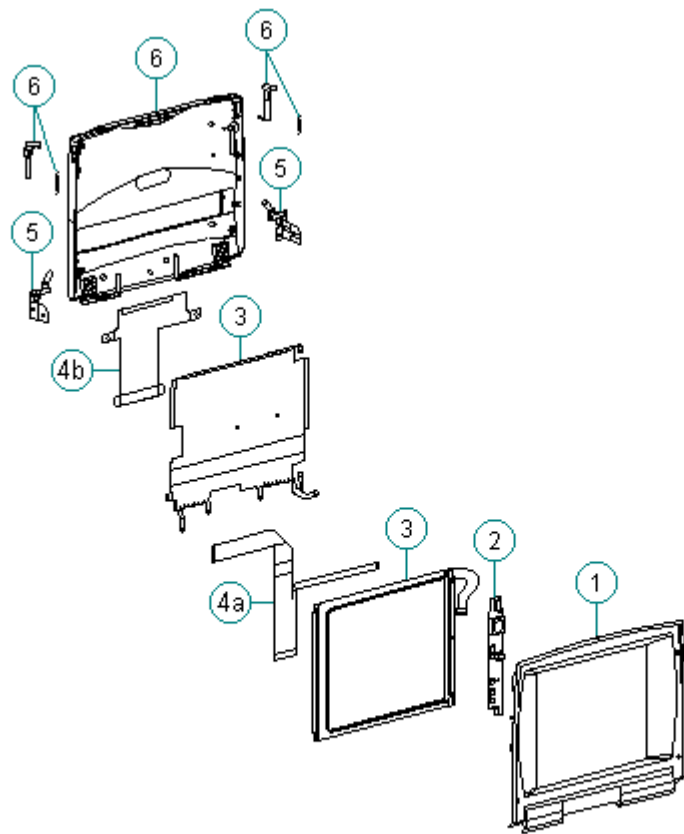

Figure 1-11. Monochrome Display Assembly for Models 400 and 410

Table 1-4. Monochrome Display Assembly -- Models 400 and 410

Description	Spare Part Number	Notes
1. Display bezel	147882-001	
2. Backlight inverter board	147622-001	
3. Display panel	147877-001	Includes labels and shield
4. Display cables	147884-001	Includes: a. display cable b. display ground cable
5. Display clutch (left and right)	147858-001	Includes screws for handle bracket, washer, tilt feet
6. Display enclosure kit	147880-001	Includes enclosure, latch, spring, and logo
7. Screw kit *	147885-001	

* Not Shown

Chapter 1.9 Color STN (9.5 inch) Display Assembly Parts

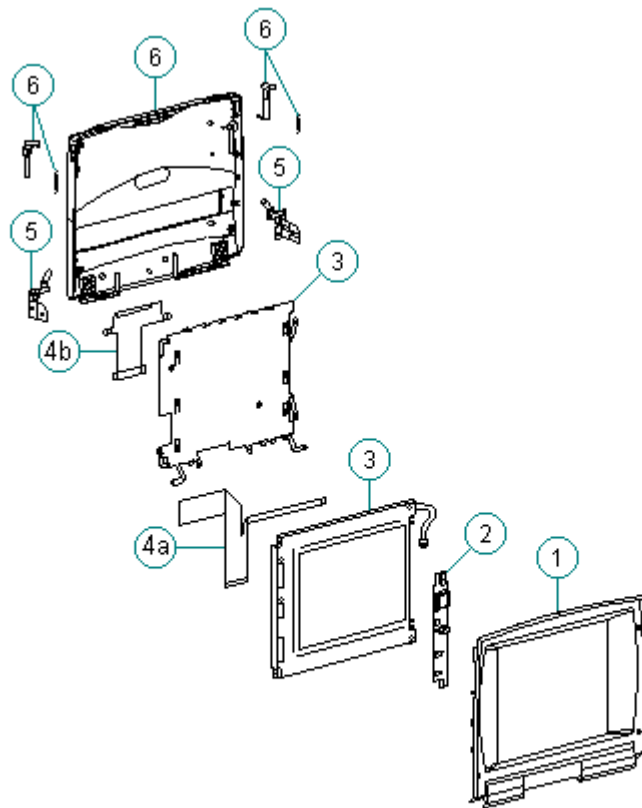

Figure 1-12. CSTN (9.5 inch) Display Assembly for Models 400 and 410

Table 1-5. CSTN (9.5 inch) Display Assembly -- Models 400 and 410

Description	Spare Part Number	Notes
1. Display bezel	147883-001	
2. Backlight inverter board	147624-001	
3. Display panel	147878-001	Includes labels and shield
4. Display cables	147884-001	Includes: a. display cable b. display ground cable
5. Display clutch (left and right)	147858-001	Includes screws for handle bracket, washer, tilt feet
6. Display enclosure kit	147881-001	Includes enclosure, latch, spring, and logo
7. Screw kit *	147885-001	

* Not Shown

Chapter 1.10 Color STN (10.4 inch) Display Assembly Parts

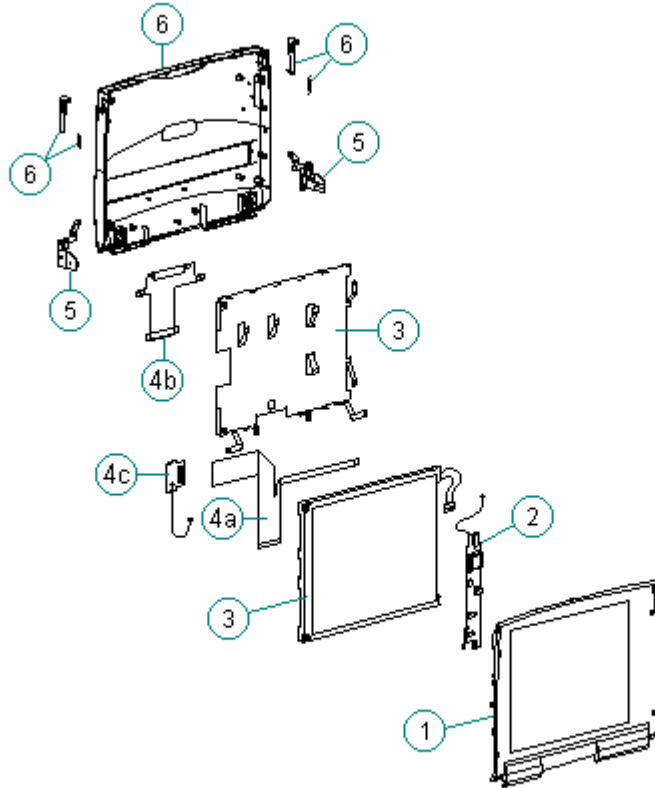

Figure 1-13. CSTN (10.4 inch) Display Assembly for Models 420 and 430

Table 1-6. CSTN (10.4 inch) Display Assembly -- Models 420 and 430

Description	Spare Part Number	Notes
1. Display bezel	189246-001	
2. Backlight inverter board	189135-001	
3. Display panel	189113-001	Includes labels and shield
4. Display cables	189247-001	Includes: a. display cable b. display ground cable c. XOVER board
5. Display clutch (left and right)	147858-001	Includes screws for handle bracket, washer, tilt feet

6. Display enclosure kit	189245-001	Includes enclosure, latch, spring, logo and pad for Sharp CSTN
7. Screw kit *	147885-001	

* Not Shown

Chapter 1.11 Color TFT (8.4 inch) Display Assembly Parts

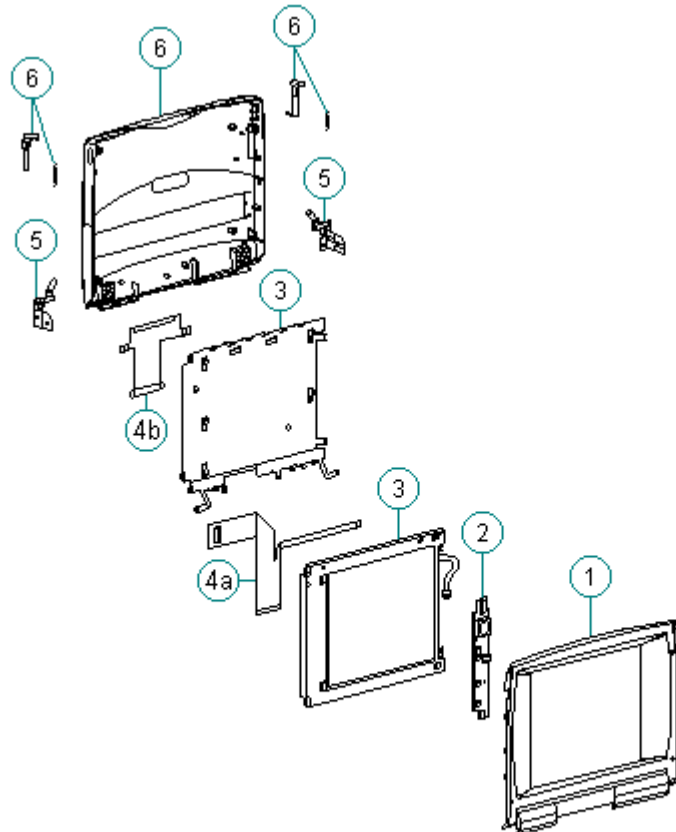

Figure 1-14. CTFT (8.4 inch) Display Assembly for Models 400 and 410

Table 1-7. CTFT (8.4 inch) Display Assembly -- Models 400 and 410

Description	Spare Part Number	Notes
1. Display bezel	147869-001	
2. Backlight inverter board	147624-001	
3. Display panel	147879-001	Includes labels and shield
4. Display cables	147884-001	Includes:

		a. display cable b. display ground cable
5. Display clutch (left and right)	147858-001	Includes screws for handle bracket, washer, tilt feet
6. Display enclosure kit	147881-001	Includes enclosure, latch, spring, and logo
7. Screw kit *	147885-001	

* Not Shown

Chapter 1.12 Color TFT (10.4 inch) Display Assembly Parts

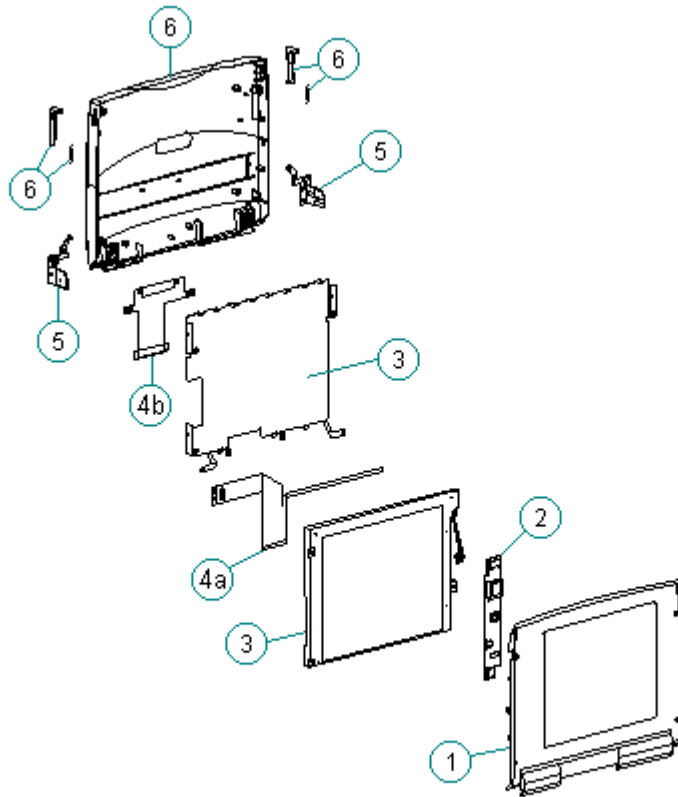

Figure 1-15. CTFT (10.4 inch) Display Assembly for Models 420 and 430

Table 1-8. CTFT (10.4 inch) Display Assembly -- Models 420 and 430

Description	Spare Part Number	Notes
1. Display bezel	189244-001	
2. Backlight inverter		

board	189136-001	
3. Display panel	189114-001	Includes labels and shield
4. Display cables	189247-001	Includes: a. display cable b. display ground cable
5. Display clutch (left and right)	147858-001	Includes screws for handle bracket, washer, tilt feet
6. Display enclosure kit	189243-001	Includes enclosure, latch, spring, and logo.
7. Screw kit *	147885-001	

* Not Shown		
=====		

Chapter 1.13 Keyboards

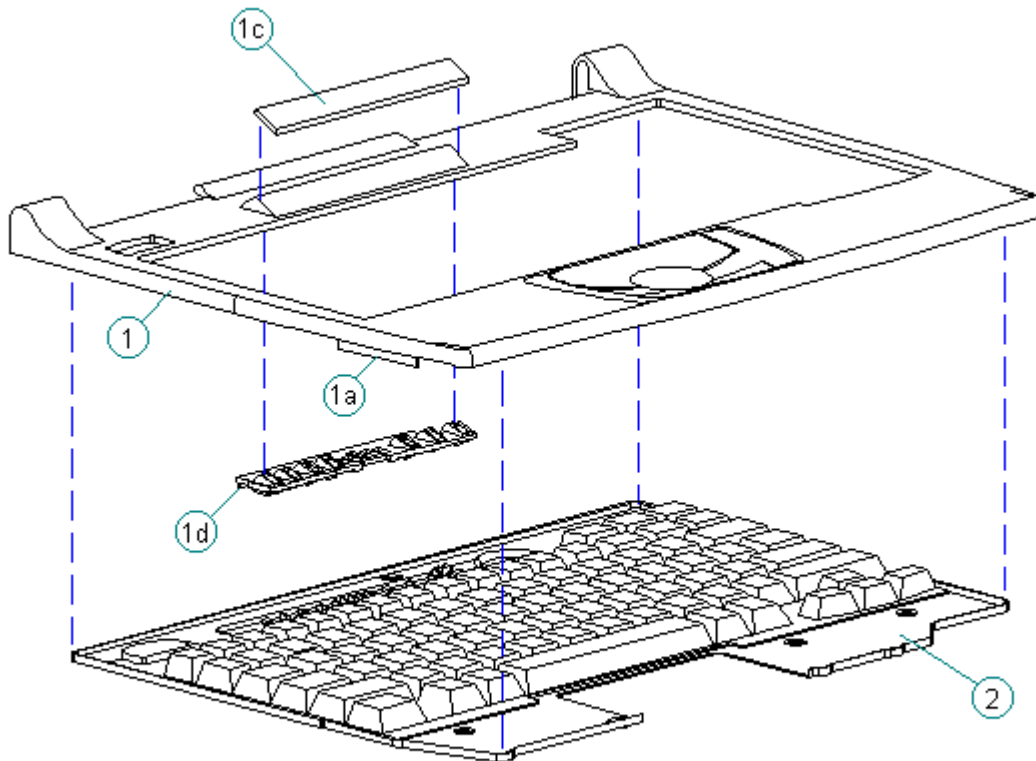

Figure 1-16. Keyboard Assembly (All Models)

Table 1-9. Contura Notebook Keyboards

=====	
Description	Spare Part Number

1. CPU Cover Includes:	147860-001
a. PC Card door	
b. spring *	
c. indicator panel	
d. light deflector	
2. U.S.	147875-001
3. U.K.	147875-003 *
4. German	147875-004 *
5. French	147875-005 *
6. Italian	147875-006 *
7. Spanish	147875-007 *
8. Danish	147875-008 *
9. Norwegian	147875-009 *
10. Swedish/Finnish	147875-010 *
11. Swiss	147875-011 *
12. French Canadian	147875-012 *
13. Portuguese	147875-013 *
14. Latin American	147875-016 *
15. Belgian	147875-018 *
16. Japanese	147875-019 *
17. Korean	147875-033 *
18. Brazilian	147875-035 *

* Not Shown

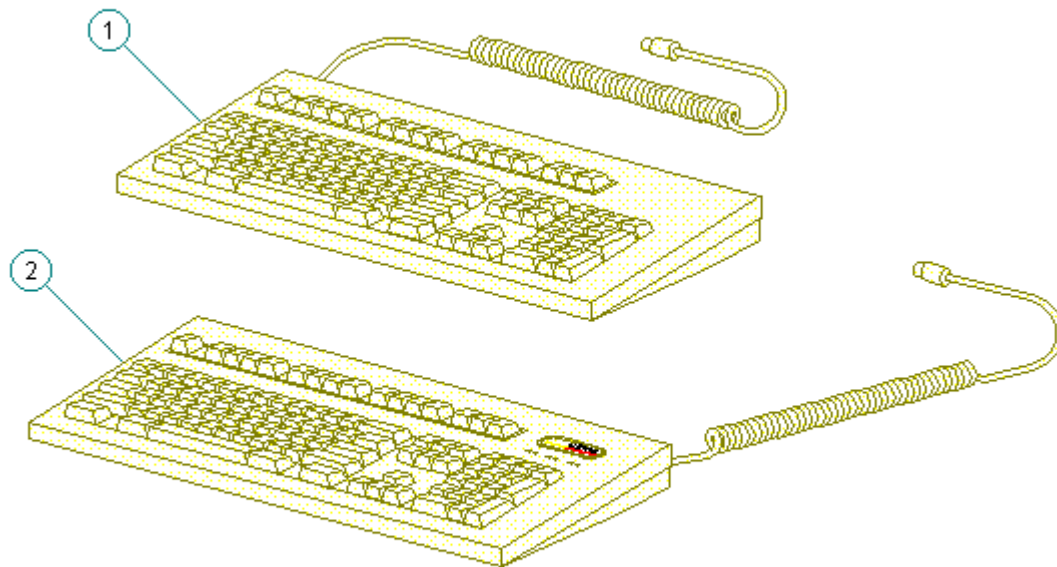

Figure 1-17. Enhanced Keyboards (All Models)

Table 1-10. Contura Enhanced Keyboards

Description	Spare Part Number
1. Enhanced II Keyboard - Domestic	140536-101
2. Enhanced III Keyboard - U.K.	140536-103
3. Enhanced III Keyboard - German	140536-104 *
4. Enhanced III Keyboard - French	140536-105 *
5. Enhanced III Keyboard - Italian	140536-106 *
6. Enhanced III Keyboard - Spanish	140536-107 *
7. Enhanced III Keyboard - Danish	140536-108 *
8. Enhanced III Keyboard - Norwegian	140536-109 *
9. Enhanced III Keyboard - Swedish/Finnish	140536-110 *
10. Enhanced III Keyboard - Swiss	140536-111 *
11. Enhanced III Keyboard - French Canadian	140536-112 *

12.	Enhanced III Keyboard - Portuguese	140536-113	*
13.	Enhanced III Keyboard - Turkish	140536-114	*
14.	Enhanced III Keyboard - Greek	140536-115	*
15.	Enhanced III Keyboard - Latin American	140536-116	*
16.	Enhanced III Keyboard - Arabic	140536-117	*
17.	Enhanced III Keyboard - Belgian	140536-118	*
18.	Enhanced III Keyboard - Japanese	140536-119	*
19.	Enhanced III Keyboard - BHCSY **	140536-120	*
20.	Enhanced III Keyboard - Hungarian	140536-121	*
21.	Enhanced III Keyboard - Polish	140536-122	*
22.	Enhanced III Keyboard - Slovakian	140536-123	*
23.	Enhanced III Keyboard - Russian	140536-124	*
24.	Enhanced III Keyboard - Czech	140536-129	*
25.	Enhanced III Keyboard - Thai	140536-130	*
26.	Enhanced III Keyboard - Beijing	140536-132	*
27.	Enhanced III Keyboard - Segul	140536-133	*
28.	Enhanced III Keyboard - Taipei	140536-134	*
29.	Enhanced III Keyboard - Brazil	140536-135	*

* Not Shown

** Bosnia-Herzegovina, Croatia, Slovenia, and Yugoslavia
=====

Chapter 1.14 Cables (Models 400 and 410)

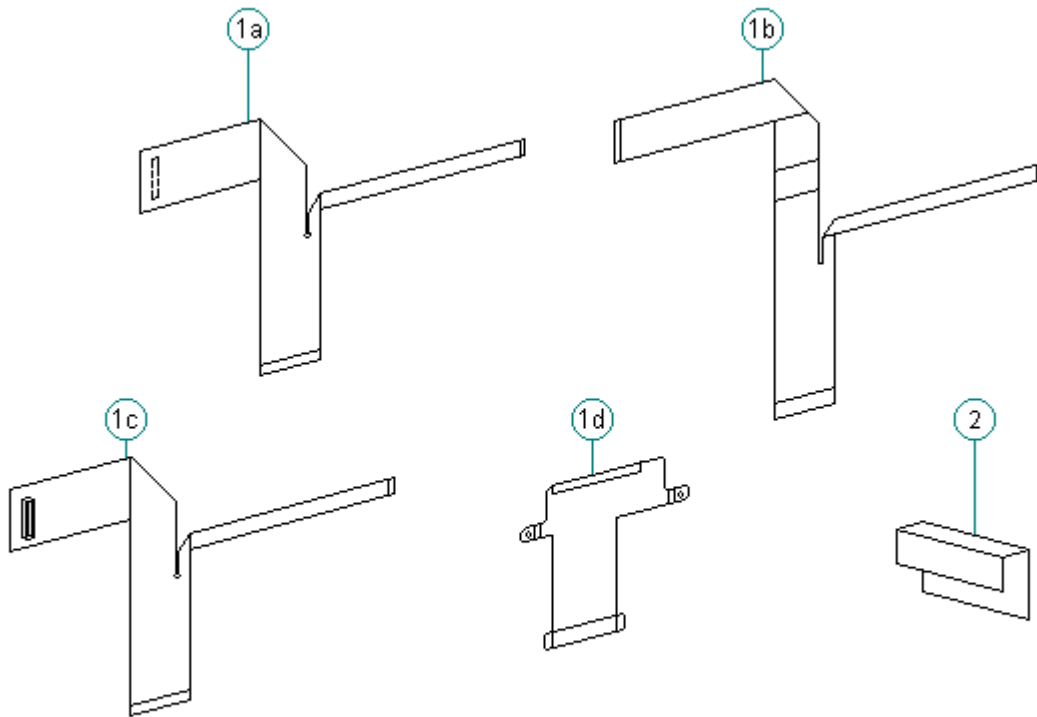

Figure 1-18. Cables for Models 400 and 410

Table 1-11. Cables for Models 400 and 410

Description	Spare Part Number
1. Display cables	147884-001
a. CSTN (9.5 in) Models 400 and 410	
b. MSTN (9.5 in) (Model 400 only)	
c. CTFT (8.4 in) Models 400 and 410	
d. Ground cable for Models 400 and 410	
2. Diskette cable	147866-001

Chapter 1.15 Cables (Models 420 and 430)

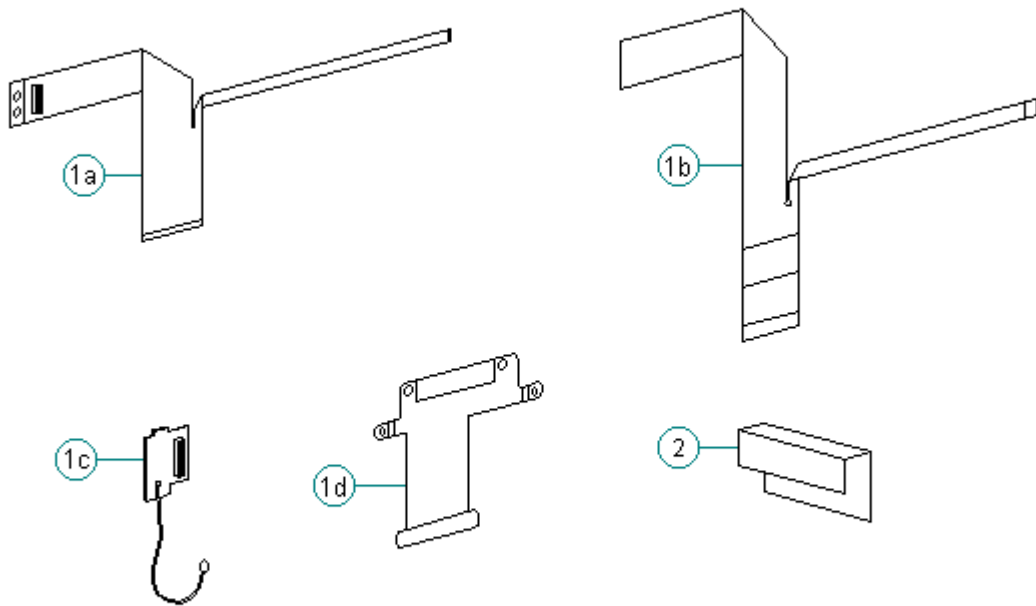

Figure 1-19. Cables for Models 420 and 430

Table 1-12. Cables for Models 420 and 430

Description	Spare Part Number
1. Display cables	189247-001
a. CTFT (10.4 in) Models 420 and 430	
b. CSTN (10.4 in) Models 420 and 430	
c. XOVER board for CSTN (10.4 in) only	
d. Ground cable for Models 420 and 430	
2. Diskette cable	147866-001

Chapter 1.16 Ac Adapter and Power Cord

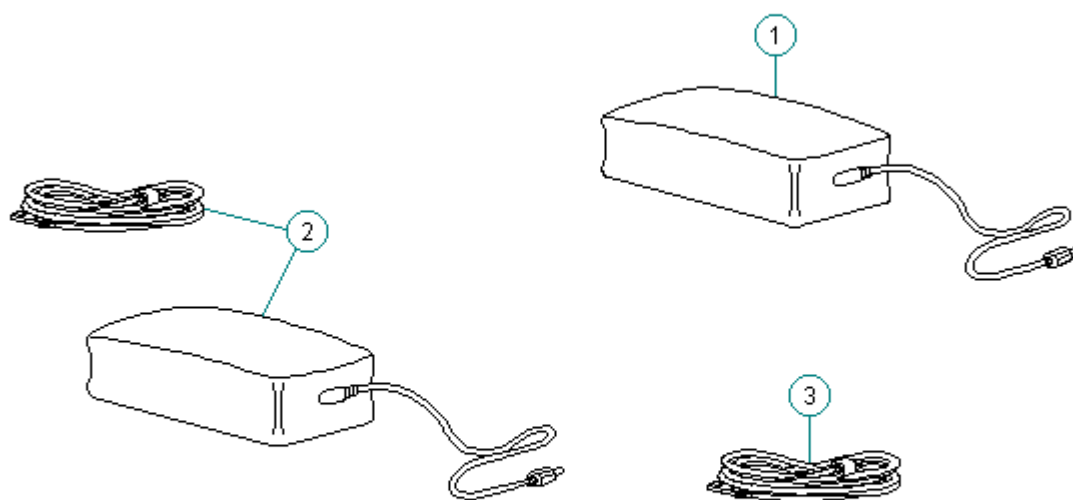

Figure 1-20. AC Adapter (All Models)

Table 1-13. Contura AC Adapter and Power Cord

Description (All Models)	Spare Part Numbers
1. AC adapter with wallprongs	147679-001
2. AC adapter	147679-002
3. Power cord (U.S./Canada)	197230-001
4. Power cord (U.K.)	197232-001 *
5. Power cord (Europe)	197231-001 *
6. Power cord (Japan)	197233-001 *
7. Power cord (Australia)	197234-001 *

* Not shown

Chapter 1.17 Memory and Processor

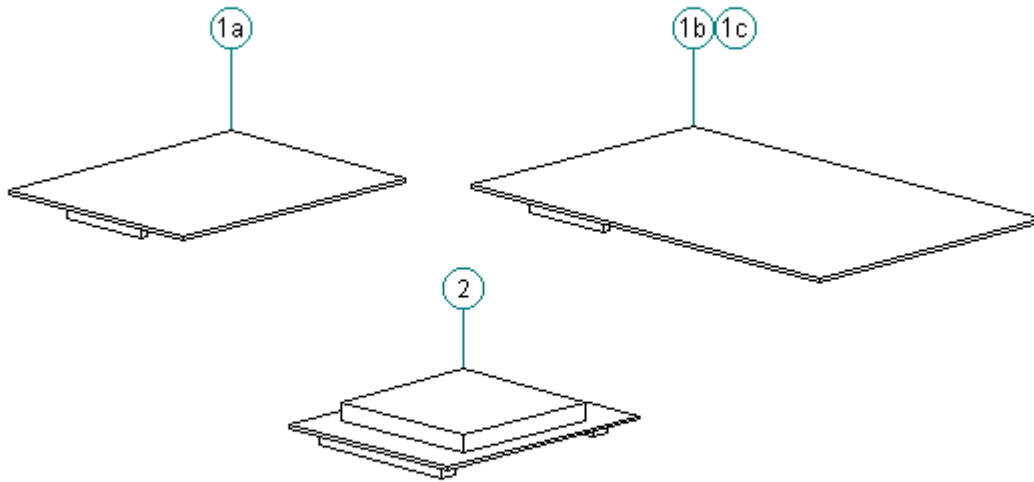

Figure 1-21. Memory and Processor Boards (All Models)

Table 1-14. Contura Memory and Processor

Description (All Models)	Spare Part Numbers
1. Memory expansion board	
a. 4 MB	147654-001
b. 8 MB	147656-001
c. 16 MB	147658-001
d. 24 MB *	189261-001
2. Processor upgrade (Model 400 only)	
486 DX2/50 MHz	169644-001

* Not Shown

Chapter 1.18 Miscellaneous Carrying Devices

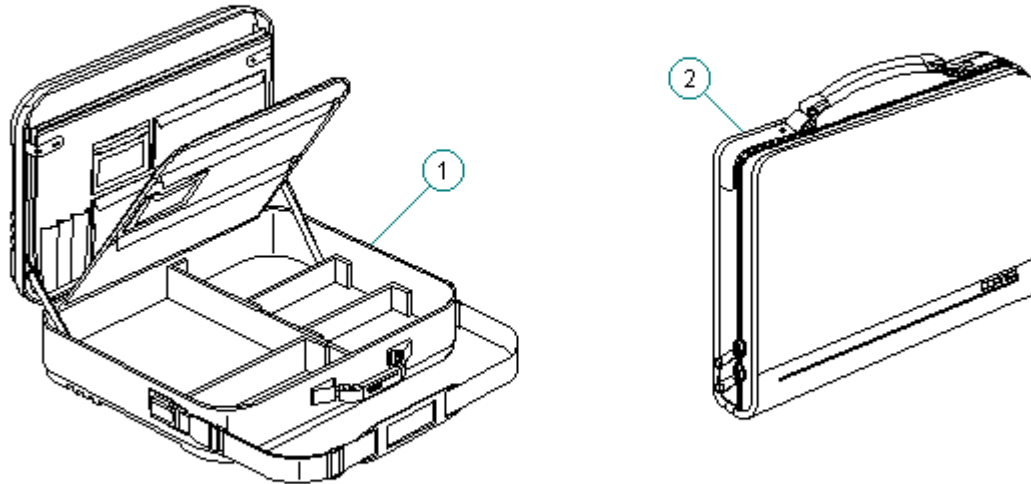

Figure 1-22. Miscellaneous Carrying Devices (All Models)

Table 1-15. Miscellaneous Carrying Devices

Description (All Models)	Spare Part Numbers
1. Briefcase, Ramie	129930-001
2. Slipcase	194162-001
3. Briefcase, SS (soft-sided)	121423-001 *

* Not Shown

Chapter 1.19 Docking Base and Monitor Support Cover

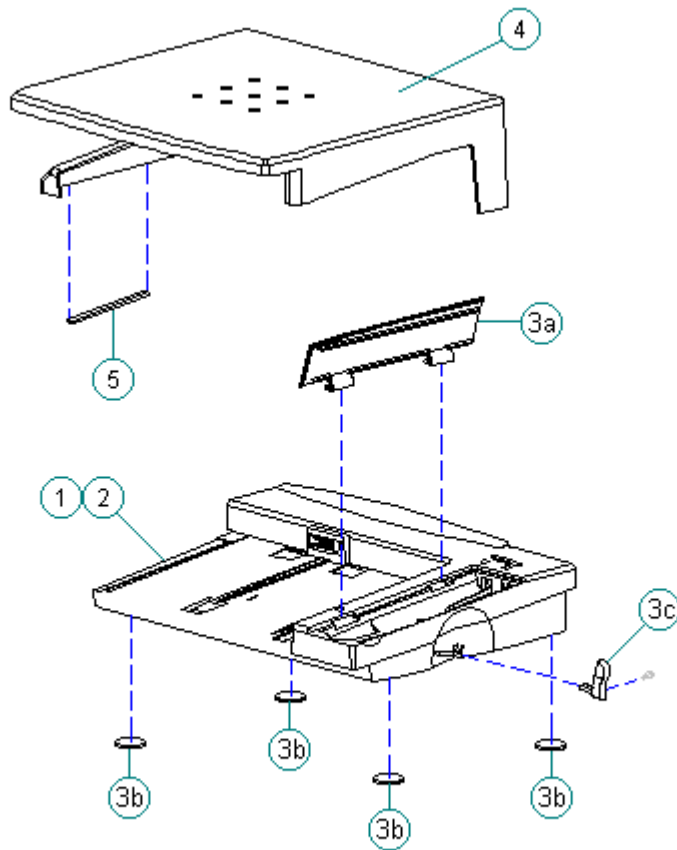

Figure 1-23. Docking Base and Monitor Support Cover (All Models)

Table 1-16. Docking Base and Monitor Support Cover

Description (All Models)	Spare Part Numbers
1. Docking Base - Ethernet	147675-001
2. Docking Base - pass-thru	147699-001
3. Docking base miscellaneous	169666-001
a. Battery door	
b. Feet	
c. Handle	
d. Screws (Quantity = 2)	
4. Monitor support cover	147676-001
5. Monitor support cover foot	169681-001
* Not Shown	

Chapter 1.20 Miscellaneous CPU Kits

Table 1-17. Miscellaneous Contura CPU Kits

Description	Spare Part Number Models 400 & 410	Spare Part Number Models 420 & 430
Handle	147678-001 *	147678-001 *
Automobile adapter	190551-002 *	190551-002 *
Memory door assembly includes hard drive tray	169713-001 *	169713-001
Carton, (Quantity = 5)	147862-001 *	147862-001 *
Carton and buns, (Quantity = 1)	147863-001 *	147863-001 *
Clutches (left and right)	147858-001 *	147858-001 *
Anti-skid feet	147859-001 *	147859-001 *
Plate logo	197251-001 *	189292-001 *
Box, 420C		189265-001 *
SpeedPaq 192 Data Fax Cellular Modem		187123-001
PC Card (PCMCIA) 288 Fax/Modem		189661-001 *
PC Card (PCMCIA) 192 Fax/Modem		188512-001 *
PC Card (PCMCIA) modem pouch		194133-001 *
CA, TEL MED		187145-001 *
Keyboard Warning Label, English		189288-001 *
Country Kit		140204-001 *
Trackball removal tool	147779-001 *	147779-001 *
Miscellaneous	147874-001 *	189262-001 *
Includes:		
Trough		
Battery latch		
Battery tray		
PC Card door		
PC Card ejection levers and pin		
Extension spring (battery eject button, display latches)		
Lock plate provision		
Keyboard ground clips		
Left clutch ground clip		
Right clutch ground clip		
Flex ground clip		
Hard Drive Tray		
* Not Shown		

Chapter 1.21 Fastener List

Table 1-18. Fastener Kit for All Models

Description:	Spare Part Number
Screws and Fastners Kit (Quantity = 25 each)	147885-001

Description	Type	Where Used	Part Number	Drive	Qty	
M2.5 x 4.0	Truss	Ground tabs on display shields	144864-001	SL/T8	3 *	
		Diskette bracket to system board			3	
		Hold down system board to base and chassis			5 *	
					4 **	
		Trackball assembly to base			1 *	
					2 **	
		Battery contracts to base/through system board			2	
M2.5 x 5.0	Truss	CPU cover to keyboard	144865-007	SL/T8	7	
		Clutches to display enclosure (Models 400 and 410)			4 *	
		CPU base to clutches			4	
					Blk	4
		Display bezel to display enclosure				
		Ground tabs on display shields (Models 420 and 430)			2 **	
		Clutches to display enclosure (Models 420 and 430)			4 **	
Display to display enclosure	4 **					
Description	Type	Where Used	Part Number	Drive	Qty	

M3.0 x 8.0	Pan	Display to display enclosure	121187-007	SL/T8	4 **
M2.5 x 24.0	Truss	CPU cover to CPU base	144865-006	SL/T8	7
M2.6 x 2.0	Fillister	Diskette drive to FDD bracket	121188-001	T8	4
M3.0 x 3.6	Truss	Hard drive to HDD bracket	121187-001	T8	4
M2.0 x 6.0	Fillister	PC Card Header	126790-004	T8	2 **
M2.0 x 15.5	Fillister	PCMCIA rails	126790-010	T8	2
Spring, torsion		PC Card door actuation	147758-001		2
Spring, extension		Battery latch return spring	147759-001		1
		Display latch return spring			2
Washer		Under handle bracket	147923-001		2
M2.5	Shoulder	Handle bracket to clutch/through CPU base	147760-001	T8	2
M2.5	Shoulder	CPU foot to clutch/through CPU base	147778-001	T8	2
4-40	Screw locks	Three connectors at rear of unit	106902-001	3/16	6
Alignment screws	Shoulder	Alignment screws for docking base connector	169643-001	T8	2

* Models 400 and 410
** Models 420 and 430

Chapter 1.22 Documentation and Software

Table 1-19. Documentation and Software

Description (All Models)	Spare Part Number
MAINTENANCE AND SERVICE GUIDE	147861-001
Online USER'S GUIDE English	147990-001

German	147990-041
French	147990-051
Italian	147990-061
Spanish	147990-071
Netherlands	147990-331
Swedish	147990-101

Manuals - English	147989-001
QUICK SETUP	
BEYOND SETUP	

Manuals - German	147989-041
QUICK SETUP	
BEYOND SETUP	
KEYBOARD REFERENCE	

Manuals - French	147989-051
QUICK SETUP	
BEYOND SETUP	
KEYBOARD REFERENCE	

Manuals - Italian	147989-061
QUICK SETUP	
BEYOND SETUP	
KEYBOARD REFERENCE	

Manuals - Spanish	147989-071
QUICK SETUP	
BEYOND SETUP	
KEYBOARD REFERENCE	

Manual - TABWORKS QUICK START GUIDE	
English	195866-001
German	195866-041
French	195866-051
Italian	195866-061
Spanish	195866-071
Swedish	195866-101
Netherlands	195866-331

Manual - AMERICA ONLINE	181194-001

Manual - MS WORKS	196077-001

Manual - ESSENTIALS OF MS-DOS AND MS-WINDOWS	
English	144958-001
German	144958-041
French	144958-051
Italian	144958-061
Spanish	144958-071
Swedish	144958-101
Portuguese	144958-131
Dutch	144958-331

Manual - MS-DOS GUIDE, 6.0 and MS Windows	
English	195973-001
German	195973-041
French	195973-051
Italian	195973-061
Spanish	195973-071

Danish	195973-081
Norwegian	195973-091
Swedish	195973-101
Portuguese	195973-131
Dutch	195973-331
Finnish	195973-351

Manual - LOTUS ORGANIZER

English	137885-001
German	137885-041
French	137885-051
Italian	137885-061
Spanish	137885-071
Danish	137885-081
Norwegian	137885-091
Swedish	137885-101
Dutch	137885-331
Finnish	137885-351

COMPAQ SERVICE QUICK REFERENCE GUIDE 106854-001

ROMPaq diskette 181088-001

Motions of bench worker	6,000 V	800 V	400 V
Removing DIPS from plastic tubes	2,000 V	700 V	400 V
Removing DIPS from vinyl trays	11,500 V	4,000 V	2,000 V
Removing DIPS from Styrofoam	14,500 V	5,000 V	3,500 V
Removing bubble pack from PCBs	26,000 V	20,000 V	7,000 V
Packing PCBs in foam-lined box	21,000 V	11,000 V	5,000 V

NOTE: 700 volts can degrade a product.
=====

Preventing Electrostatic Damage to Equipment

Many electronic components are sensitive to ESD. Circuitry design and structure determine the degree of sensitivity. The following proper packaging and grounding precautions are necessary to prevent damage:

- o Protect all electrostatic parts and assemblies with conductive or approved containers or packaging.
- o Keep electrostatic sensitive parts in their containers until they arrive at static-free stations.
- o Place items on a grounded surface before removing them from their container.
- o Always be properly grounded when touching a sensitive component or assembly.
- o Place reusable electronic-sensitive parts from assemblies in protective packaging or conductive foam.

Use transporters and conveyors made of anti-static belts and metal roller bushings. Mechanized equipment used for moving materials must be wired to ground and proper materials selected to avoid static charging. When grounding is not possible, use an ionizer to dissipate electric charges.

Preventing Damage to Drives

To prevent static damage to hard drives, use the following precautions:

- o Handle drives gently, using static-guarding techniques.
- o Store drives in the original shipping containers.
- o Avoid dropping drives from any height onto any surface.
- o Handle drives on surfaces that have at least one inch of shock proof foam.
- o Always place drives PCB assembly side down on the foam.

Grounding Methods

The method for grounding must include a wrist strap or a foot strap at a grounded workstation. When seated, wear a wrist strap connected to a grounded system. When standing, use footstraps and a grounded floor mat.

Table 2-2. Static-Shielding Protection Levels

Method	Voltages
Anti-static Plastic	1,500
Carbon-Loaded Plastic	7,500
Metallized Laminate	15,000

Grounding Workstations

To prevent static damage at the workstation, follow these precautions:

- o Cover the workstation with approved static-dissipative material. Provide a wrist strap connected to the work surface and properly grounded tools and equipment.
- o Use static-dissipative mats, heel straps, or air ionizers to give added protection.
- o Handle electrostatic sensitive components, parts, and assemblies by the case or PCB laminate. Handle them only at static-free workstations.
- o Avoid contact with pins, leads, or circuitry.
- o Turn off power and input signals before inserting and removing connectors or test equipment.
- o Use fixtures made of static-safe materials when fixtures must directly contact dissipative surfaces.
- o Keep work area free of nonconductive materials such as ordinary plastic assembly aids and Styrofoam.

Grounding Equipment

Use the following equipment to prevent static electricity damage to the equipment:

Wrist Straps are flexible straps with a minimum of 1 megohm +/-10% resistance to the ground cords. To provide proper ground, a strap must be worn snug against the skin. On grounded mats without banana-plug connectors, connect a wrist strap with alligator clips.

Heelstraps/Toestraps/Bootstraps can be used at standing workstations and are compatible with most types of boots and shoes. On conductive floors or

dissipative floor mats, use straps on both feet with a minimum of 1 megohm of resistance between operator and ground. To be effective, the conductive strips must be worn in contact with the skin.

Field service tools, such as cutters, screwdrivers, vacuums, that are conductive.

Portable field service kit with a static dissipative vinyl pouch that folds out of a work mat. Also use a wrist strap and a ground cord for the work surface. Ground the cord to the chassis of the equipment undergoing test or repair.

Recommended Materials and Equipment

Other materials and equipment that are recommended for use in preventing static electricity include:

- o Anti-static tape
- o Anti-static smocks, aprons, or sleeve protectors
- o Conductive bins, and other assembly or soldering aids
- o Conductive foam
- o Conductive table-top workstations with ground cord of 1 megohm of resistance
- o Static dissipative table or floor mats with hard tie to ground
- o Field service kits
- o Static awareness labels
- o Wrist straps and footwear straps providing 1 megohm +/- 10% resistance
- o Material handling packages
- o Conductive plastic bags
- o Conductive plastic tubes
- o Conductive tote boxes
- o Metal tote boxes
- o Opaque shielding bags
- o Transparent metallized shielding bags
- o Transparent shielding tubes

Chapter 2.2 Service Preliminaries

Some of the service preliminaries that should be kept in mind during the disassembly and assembly of the computer include:

Chapter 3. Removal and Replacement Procedures

Introduction

This chapter provides complete removal and replacement procedures for the Compaq Contura 400 Family of Personal Computers. Procedures that apply to specific models are indicated in parenthesis.

After completing removal and replacement procedures, run the diagnostics program to verify that all components operate properly.

For replacement procedures, follow the removal procedures in reverse order unless otherwise specified.

Chapter 3.1 Disassembly/Assembly Sequence Chart

This chart shows the order in which disassembly procedures are provided:

```
|-- 3.2 PREPARING THE COMPUTER
|   |-- AC Adapter
|   |-- Battery pack
|-- 3.3 HANDLE BRACKET
|-- 3.4 TILT FEET
|-- 3.5 HARD DRIVE
|-- 3.6 MEMORY EXPANSION BOARD
|-- 3.7 KEYBOARD ASSEMBLY
|   |-- CPU cover
|   |-- Keyboard
|-- 3.8 BATTERY COMPARTMENT COMPONENTS
|   |-- Battery compartment
|   |-- Anti-skid pad
|   |-- Battery release spring and button
|-- 3.9 REAL-TIME CLOCK BATTERY (Models 400 and 410)
|-- 3.10 REAL-TIME CLOCK BATTERY (Models 420 and 430)
|-- 3.11 PROCESSOR UPGRADE OPTION (Model 400 Only)
|-- 3.12 INTEGRATED MECHANICAL TRACKBALL ASSEMBLY
|   |-- (Model 400 and 410)
|-- 3.13 INTEGRATED OPTICAL TRACKBALL ASSEMBLY
|-- 3.14 DISKETTE DRIVE (All Models)
|   |-- Diskette drive
|   |-- Diskette drive bracket
|-- 3.15 THE SYSTEM BOARD (All Models)
```

- 3.16 PC Card (PCMCIA) ASSEMBLY
- 3.17 PC Card (PCMCIA) EJECTION LEVERS AND PIN
- 3.18 PC Card (PCMCIA) DOORS AND SPRINGS
- 3.19 SYSTEM CHASSIS
 - |-- Trough
- 3.20 CPU BASE
 - |-- Battery shield clip
 - |-- Lock provision plate
 - |-- Anti-skid pads
- 3.21 DISPLAY ASSEMBLY COMPONENTS (Models 400 and 410)
 - |-- Bezel
 - |-- Latches
 - |-- Inverter board
- 3.22 MONOCHROME DISPLAY (Models 400 and 410)
 - |-- LCD Panel with Shield attached
 - |-- Display cable
 - |-- Display ground cable
- 3.23 COLOR STN (9.5") DISPLAY (Models 400 and 410)
 - |-- LCD Panel
 - |-- Shield
 - |-- Display cable
 - |-- Display ground cable
- 3.24 COLOR TFT (8.4") DISPLAY (Models 400 and 410)
 - |-- LCD Panel
 - |-- Shield
 - |-- Display cable
 - |-- Display ground cable
- 3.25 DISPLAY COMPONENTS (Models 420 and 430)
 - |-- Bezel
 - |-- Latches
 - |-- Inverter board
- 3.26 COLOR STN (10.4") DISPLAY (Models 420 and 430)
 - |-- LCD Panel
 - |-- Shield
 - |-- Display cable
 - |-- Display ground cable
- 3.27 COLOR TFT (10.4") DISPLAY (Models 420 and 430)
 - |-- LCD Panel
 - |-- Shield
 - |-- Display cable
 - |-- Display ground cable
- 3.28 DISPLAY ENCLOSURE
- 3.29 CLUTCHES AND GROUND CLIPS
- 3.30 DOCKING BASE
 - |-- Feet
 - |-- Battery door

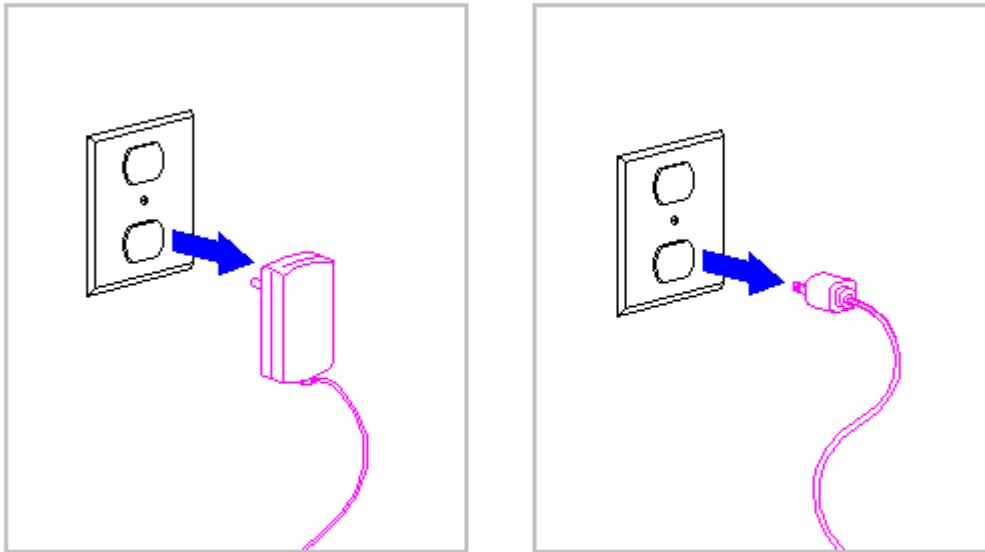

Figure 3-1. Disconnecting the AC Adapter from the Electrical Outlet

5. Disconnect the AC Adapter power cord from the computer (Figure 3-2).
6. Eject the diskette (Figure 3-2) and PC Card, if installed.

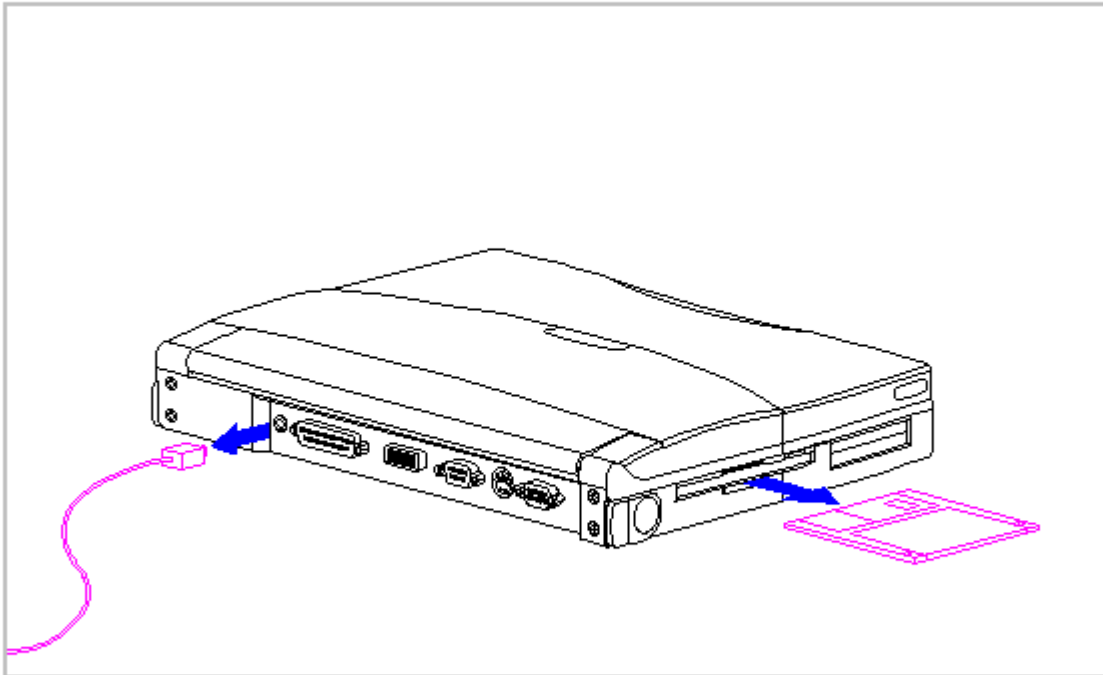

Figure 3-2. Disconnecting the AC Adapter and Ejecting the Diskette

7. Open the battery compartment by lifting up the front of the computer [1] and sliding the battery compartment release button to the right [2]. The battery compartment opens slightly. Lower the compartment [3] (Figure 3-3).

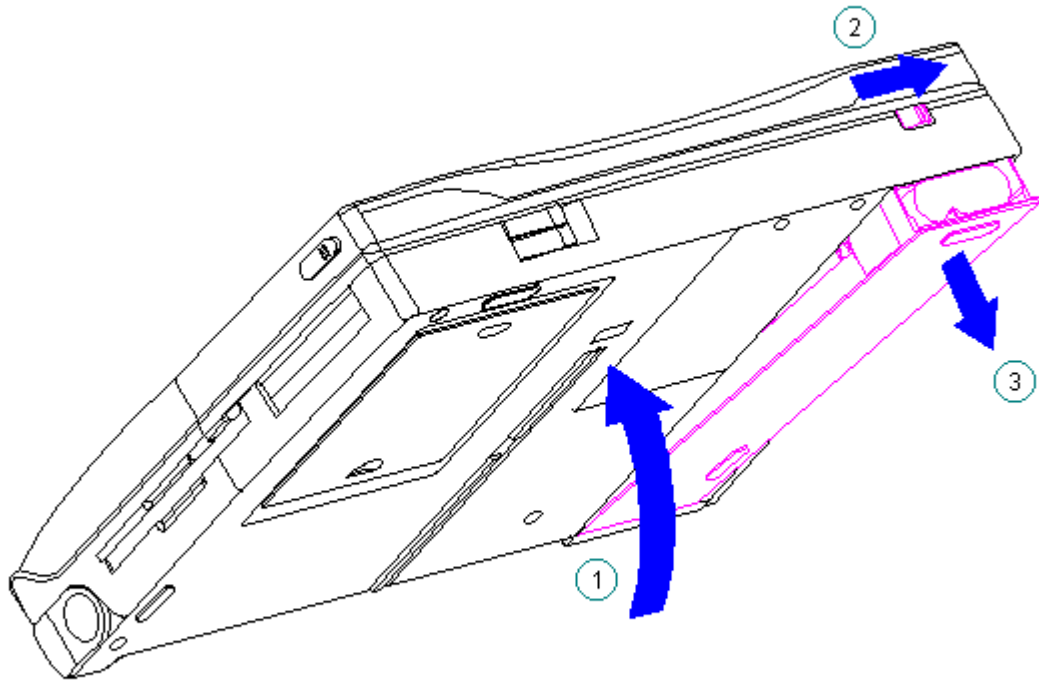

Figure 3-3. Opening the Battery Compartment

8. Remove the battery pack (Figure 3-4).

2. Close the computer and turn it top-side down.
3. Move the tilt foot toward the front of the computer, exposing the handle bracket screw on either side of the computer (Figure 3-5).

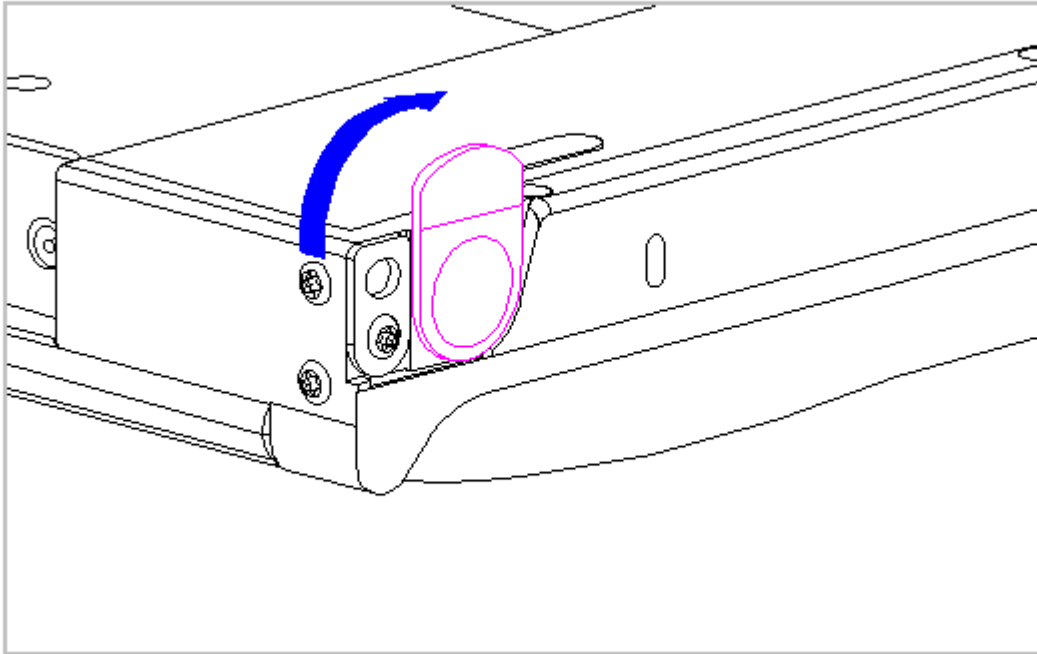

Figure 3-5. Positioning the Tilt Foot

4. Using a Torx T8 , remove the screw and washer from each handle bracket. These screws are not reusable and must be discarded.
5. Remove the handle bracket (Figure 3-6).

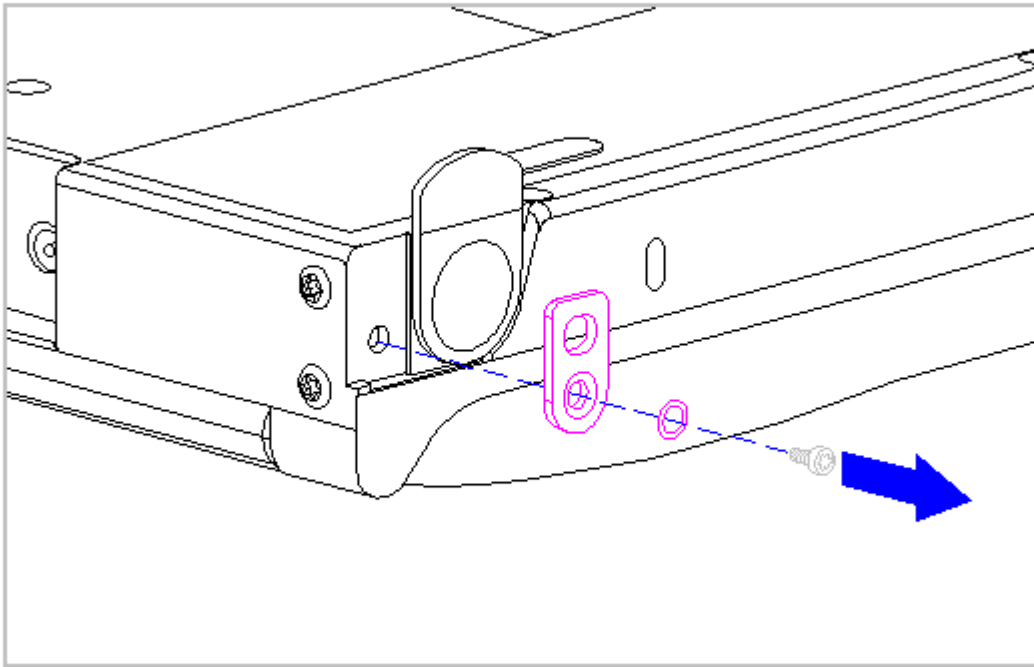

Figure 3-6. Removing the Handle Bracket

6. To install the handle bracket, reverse the previous steps. Discard the old screws and replace with new screws.

Chapter 3.4 Tilt Feet

This procedure is necessary if replacing the tilt feet or if separating the display assembly from the system unit module.

Removing the Tilt Feet

To remove the tilt feet, follow these steps:

1. Disconnect all power from the computer and remove the AC Adapter and battery pack (Section 3.2).
2. Using a Torx T8 , remove the tilt foot screw (Figure 3-7). Screws from the tilt feet are not reusable and must be discarded.
3. Remove the tilt foot (Figure 3-7).

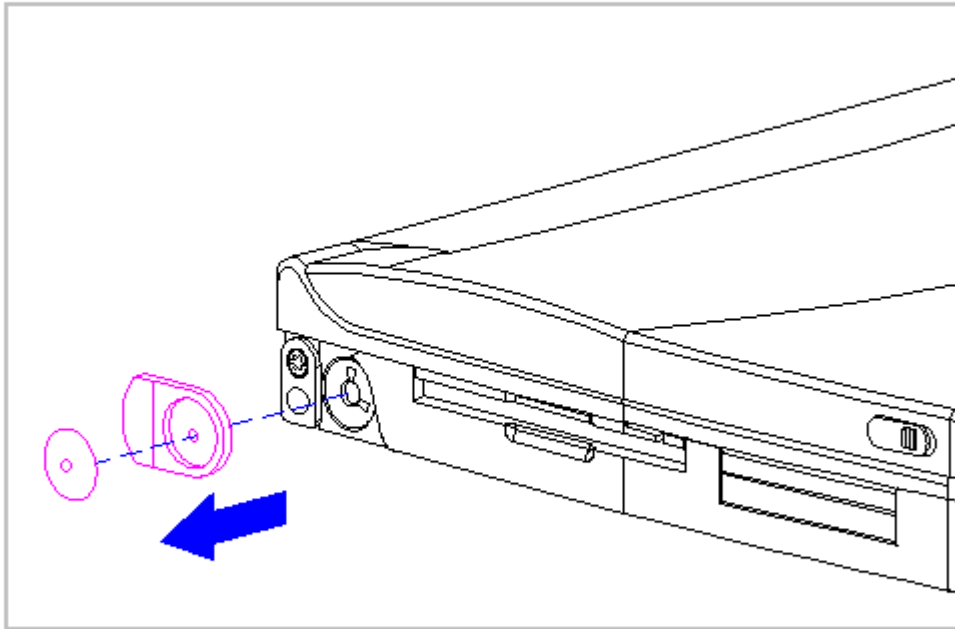

Figure 3-7. Removing the Tilt Foot

4. To install the tilt foot, reverse the previous steps. Discard the old screws and replace with new screws.

Chapter 3.5 Hard Drive

This section contains removal procedures for the following hard drive components:

- o Hard drive compartment cover
- o Hard drive
- o Hard drive bracket

Removing the Hard Drive Compartment Cover

To remove the hard drive compartment cover, follow these steps:

1. Disconnect all power from the computer and remove the battery pack, diskette, and PC Card, if installed (Section 3.2).

2. Close the computer and turn it top-side down.
3. Using a Torx T-8 or flat-bladed screwdriver, remove the two screws from the hard drive compartment cover (Figure 3-8).

NOTE: These two screws also secure the CPU base to the keyboard and must be removed in order to remove the keyboard and access system components.

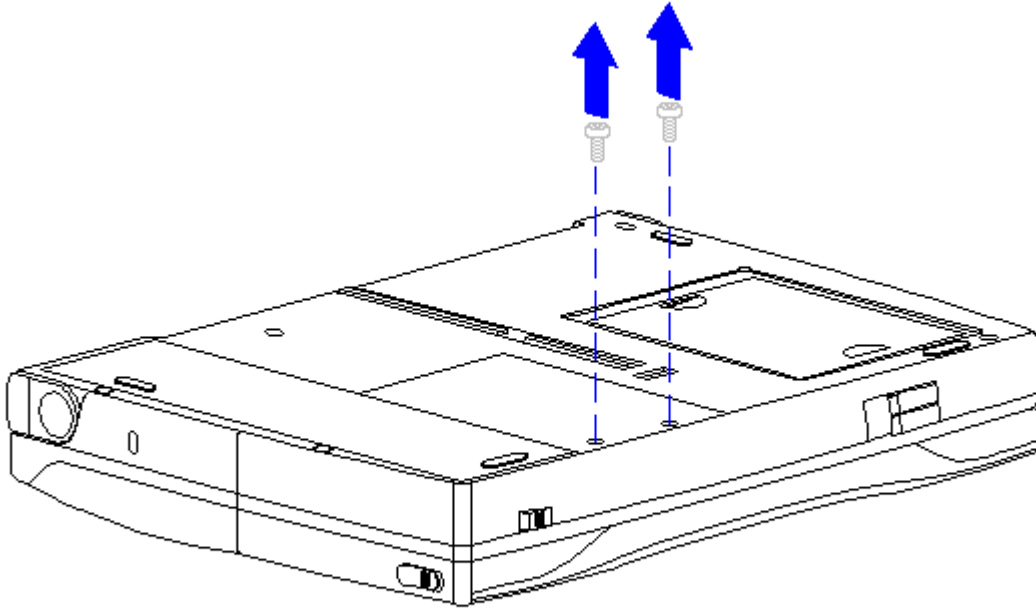

Figure 3-8. Removing Screws from the Hard Drive Compartment Cover (All Models)

4. Use a Case utility tool to remove the hard drive compartment cover (Figure 3-9).

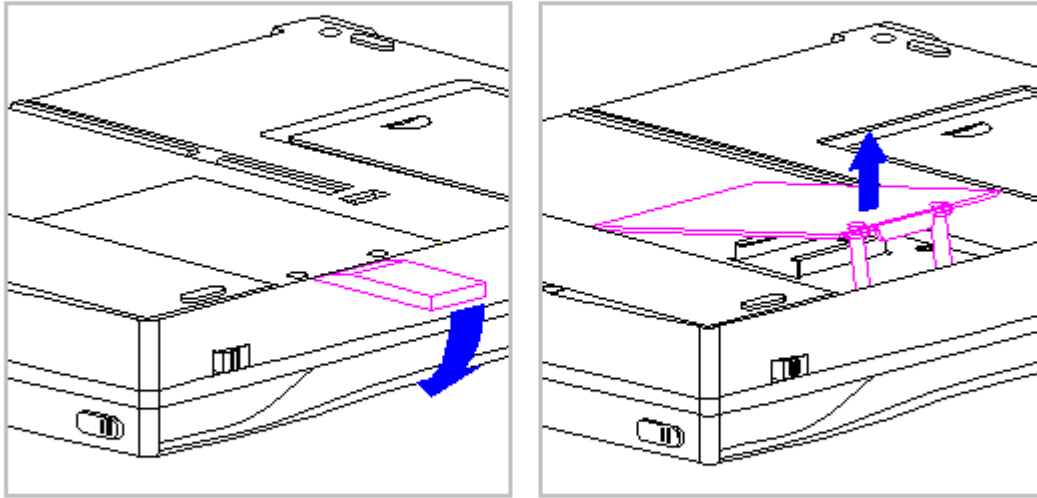

Figure 3-9. Removing the Hard Drive Compartment Cover (All Models)

5. To replace the hard drive compartment cover, reverse the previous steps making sure to insert the bracket's tab under the plastic edge.

Removing the Hard Drive

1. Remove the hard drive compartment cover. Refer to "Removing the Hard Drive Compartment Cover" in this section.
2. Remove the hard drive by grasping the hard drive bracket and sliding it toward the front of the computer [1] (Figure 3-10).
3. Lift the hard drive and bracket [2] up and out of the computer (Figure 3-10).

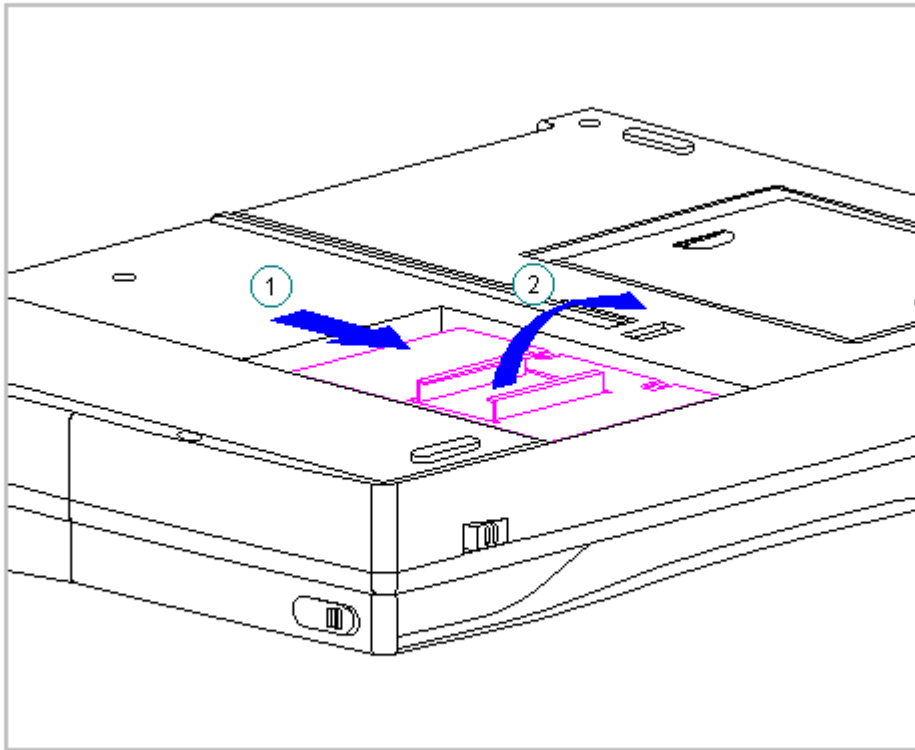

Figure 3-10. Removing the Hard Drive and Hard Drive Bracket (All Models)

4. To replace the hard drive, reverse the previous steps.

Removing the Hard Drive Bracket

1. Remove the hard drive compartment cover. Refer to "Removing the Hard Drive Compartment Cover" in this section.
2. Remove the hard drive and bracket. Refer to "Removing the Hard Drive" in this section.
3. Using a Torx T8 , remove the four screws from the hard drive bracket and separate the bracket from the hard drive (Figure 3-11).

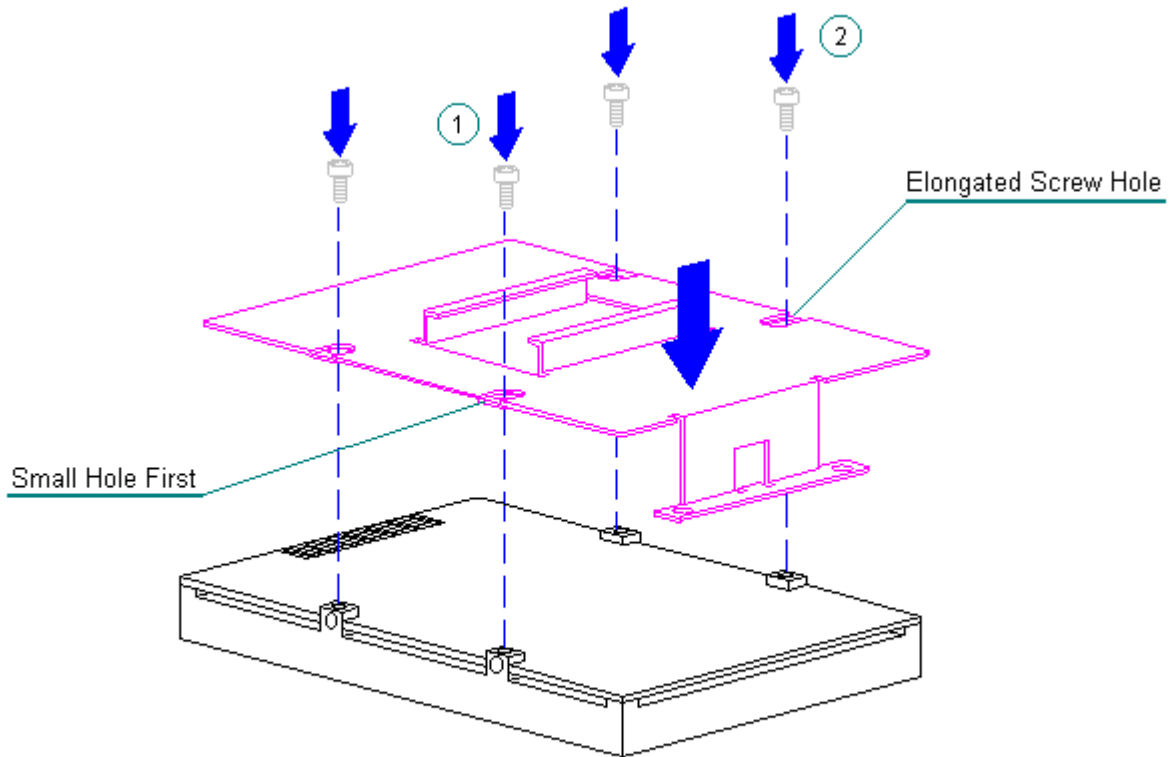

Figure 3-12. Replacing the Hard Drive Bracket (All Models)

Chapter 3.6 Memory Expansion Board

This section contains removal and replacement procedures for the memory compartment cover and the memory expansion board.

The memory compartment cover and the bottom of the CPU base are embossed with arrows and two icons that indicate whether the memory compartment cover is unlocked [1] or locked [2].

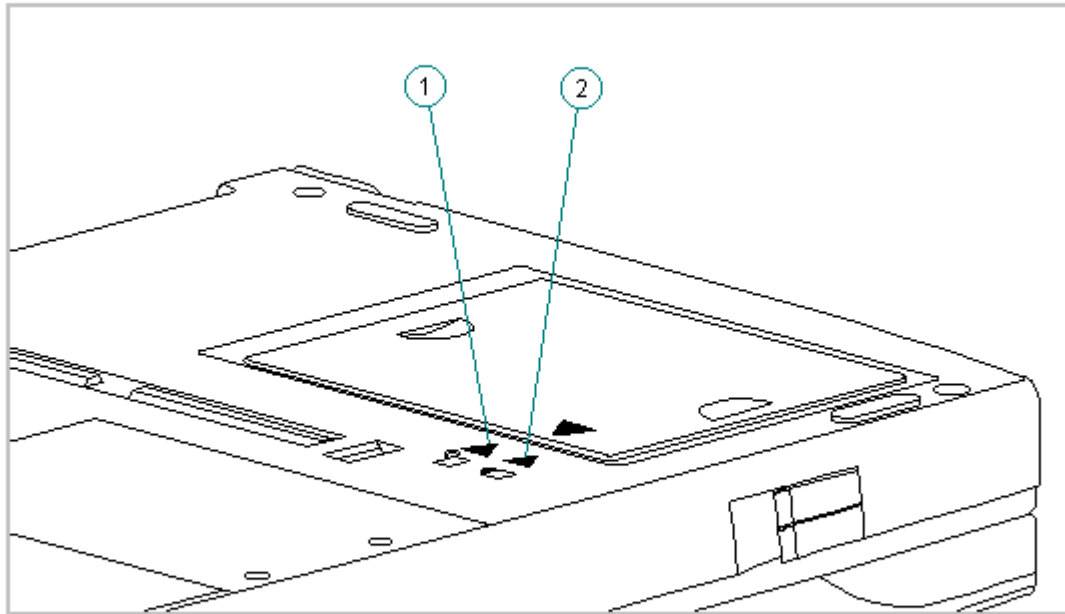

Figure 3-13. Memory Compartment Cover Icons (All Models)

Removing and Replacing the Memory Compartment Cover

To remove the memory compartment cover, follow these steps:

1. Disconnect all power from the computer and remove the battery pack, diskette, and PC Card, if installed (Section 3.2).
2. Close the computer and turn it top-side down.
3. Slide the memory compartment cover toward the rear of the computer and lift up (Figure 3-14).

IMPORTANT: Be sure to maintain the same orientation of the cover to the computer when removing and replacing.

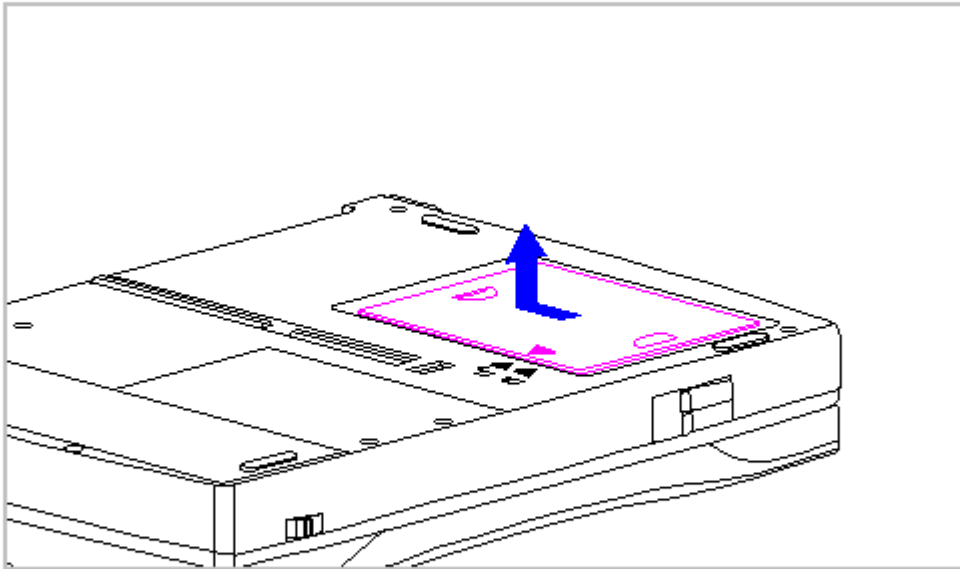

Figure 3-14. Removing the Memory Compartment Cover (All Models)

4. To replace the memory compartment cover, reverse the previous steps.

Removing the Memory Expansion Board

To remove the memory expansion board, follow these steps:

1. Remove the memory compartment cover. Refer to "Removing and Replacing the Memory Compartment Cover" in this section.
2. Gently rock the memory expansion board back and forth, disconnecting the board from both connectors (Figure 3-15).

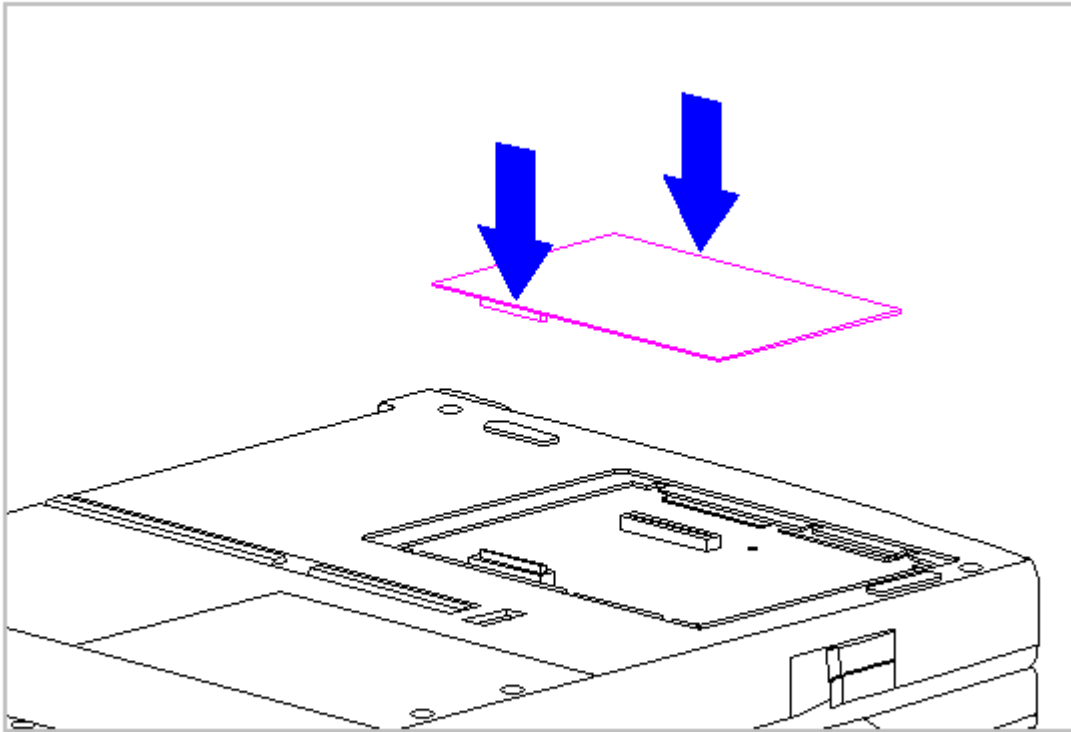

Figure 3-16. Replacing the Memory Expansion Board (All Models)

3. Replace the memory compartment cover. Refer to "Removing and Replacing the Memory Compartment Cover" in this section.

Chapter 3.7 Keyboard Assembly

This section contains removal and replacement procedures for the following the keyboard assembly components:

- o CPU cover
- o Keyboard
- o Top PC Card door and spring

NOTE: The bottom PC Card door and spring are part of the CPU base.

Removing the Keyboard Assembly

To remove the keyboard assembly, follow these steps:

1. Disconnect all power from the computer and remove the AC Adapter and

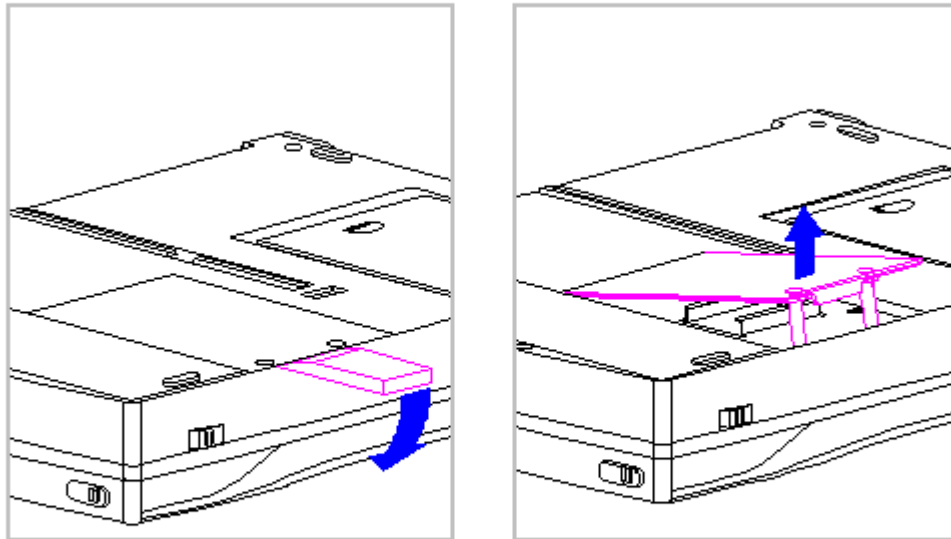

Figure 3-18. Removing the Hard Drive Compartment Cover (All Models)

4. Use a case utility tool to remove the hard drive compartment cover (Figure 3-18).
5. Carefully, turn the computer top-side up and open the display to its fully opened position (135-degree angle) (Figure 3-19).

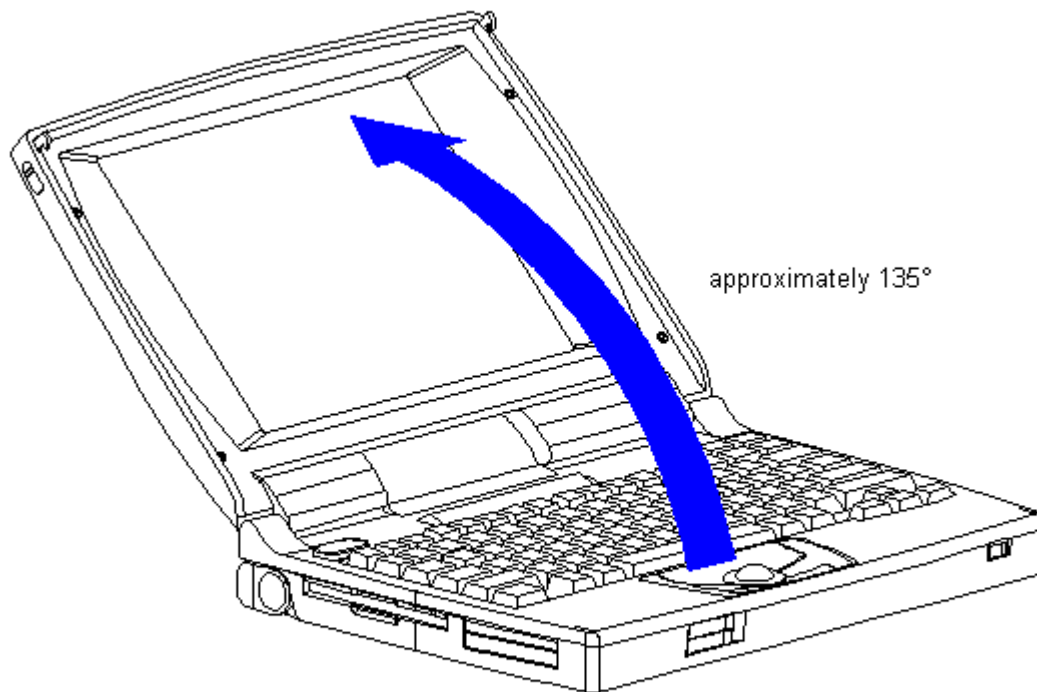

Figure 3-19. Opening the Display to a 135-degree Angle (All Models)

6. Using the case utility tool, lift up the outside rear corners of the keyboard assembly to release the keyboard snaps [1], and tilt the keyboard assembly toward you to release the keyboard connector [2] (Figure 3-20).

IMPORTANT: When using the case utility tool, use care to keep it out of the diskette drive area.

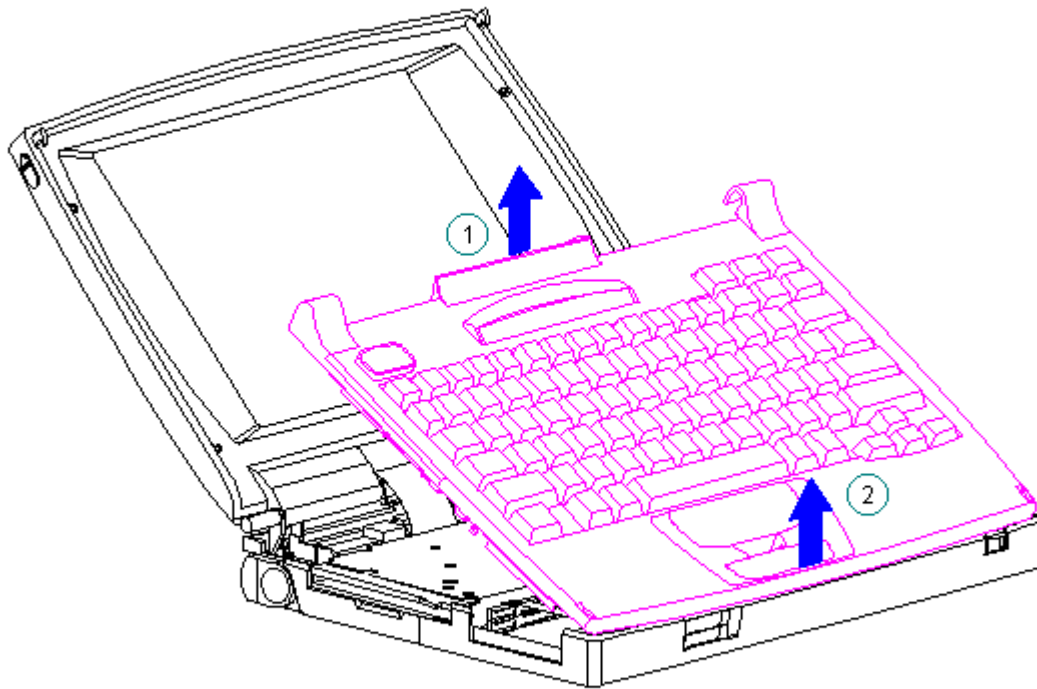

Figure 3-21. Removing the Keyboard Assembly (All Models)

8. Position the display to a 90-degree angle (Figure 3-22).

4. Separate the CPU cover from the keyboard (Figure 3-23).

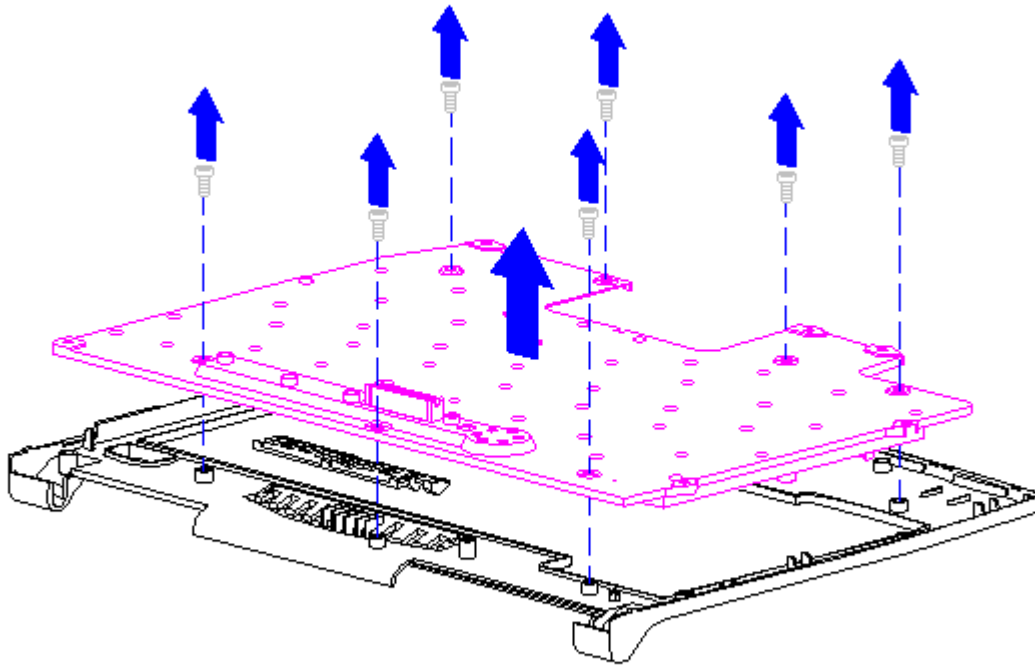

Figure 3-23. Removing the CPU Cover from the Keyboard (All Models)

5. To replace the CPU cover, reverse the previous steps.

Removing the Top PC Card (PCMCIA) Door and Spring

To remove the top PC Card door and spring from the keyboard assembly, follow these steps:

1. Remove the keyboard assembly from the computer. Refer to "Removing the Keyboard Assembly" in this section.
2. Turn the keyboard assembly top-side down.
3. Remove the PC Card door from the keyboard assembly, unsnap the PC Card door [1] from the posts, and remove the door (Figure 3-24).
4. Remove the spring [2] from the PC Card door (Figure 3-24).

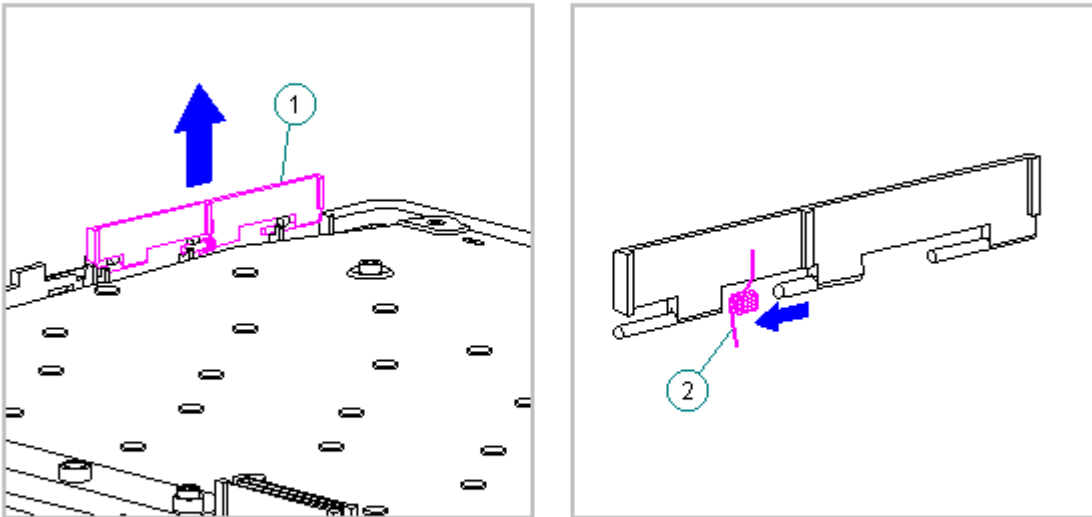

Figure 3-24. Removing the PC Card Door and Spring from the Keyboard Assembly (All Models)

Replacing the Top PC Card (PCMCIA) Door and Spring

To replace the top PC Card Door and Spring to the keyboard assembly, follow these steps:

1. Install the PC Card spring on the door post, ensuring that the bent arm of the spring is placed against the rib on the PC Card door (Figure 3-25).

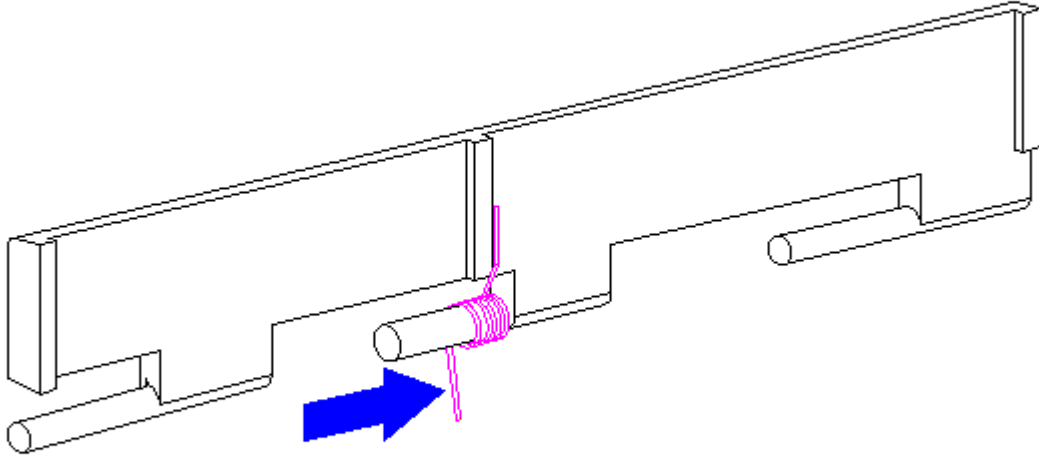

Figure 3-25. Replacing the PC Card Spring (All Models)

2. Install the PC Card (PCMCIA) door, ensuring that the spring is placed between the post [1] and the rib [2] (Figure 3-26).

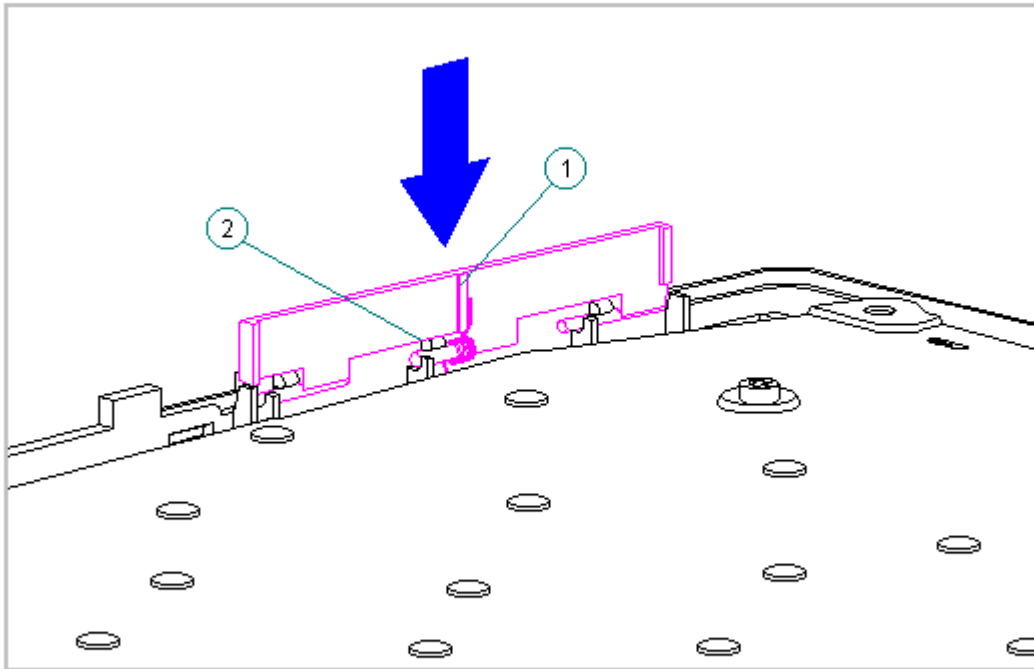

Figure 3-26. Replacing the PC Card Door (All Models)

Replacing the Keyboard Assembly

If installing a new keyboard assembly, the hook and loop fastener will have to be attached to the diskette drive bracket:

To attach the hook and loop fastener to the diskette drive bracket, follow these steps:

1. Separate the new hook and loop fastener.
2. Attach the opposite color of the hook and loop fastener to the existing hook and loop fastener on the tab on the diskette drive bracket [1] (Figure 3-27).
3. Remove the top layer from the hook and loop fastener to expose the adhesive strip prior to replacing the keyboard assembly [2] (Figure 3-27).

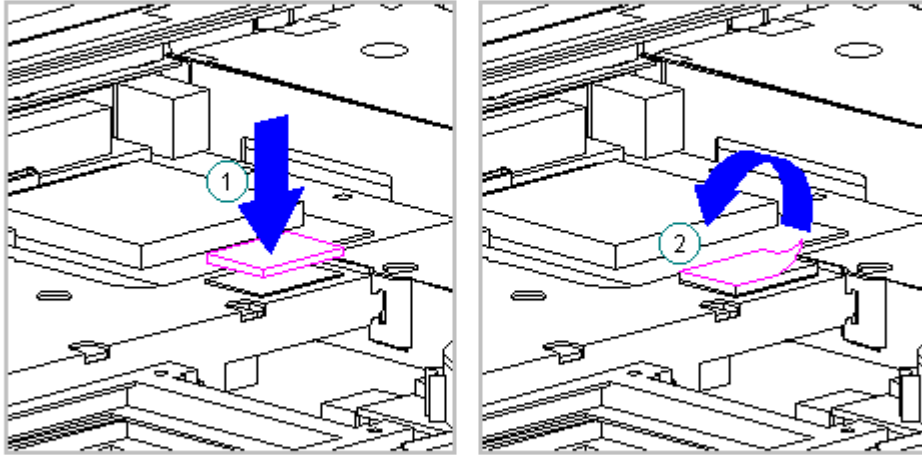

Figure 3-27. Attaching the Hook and Loop Fastener (All Models)

To replace the existing keyboard assembly in the computer, follow these steps:

1. Open the display to its fully opened position of 135-degrees (Figure 3-28).

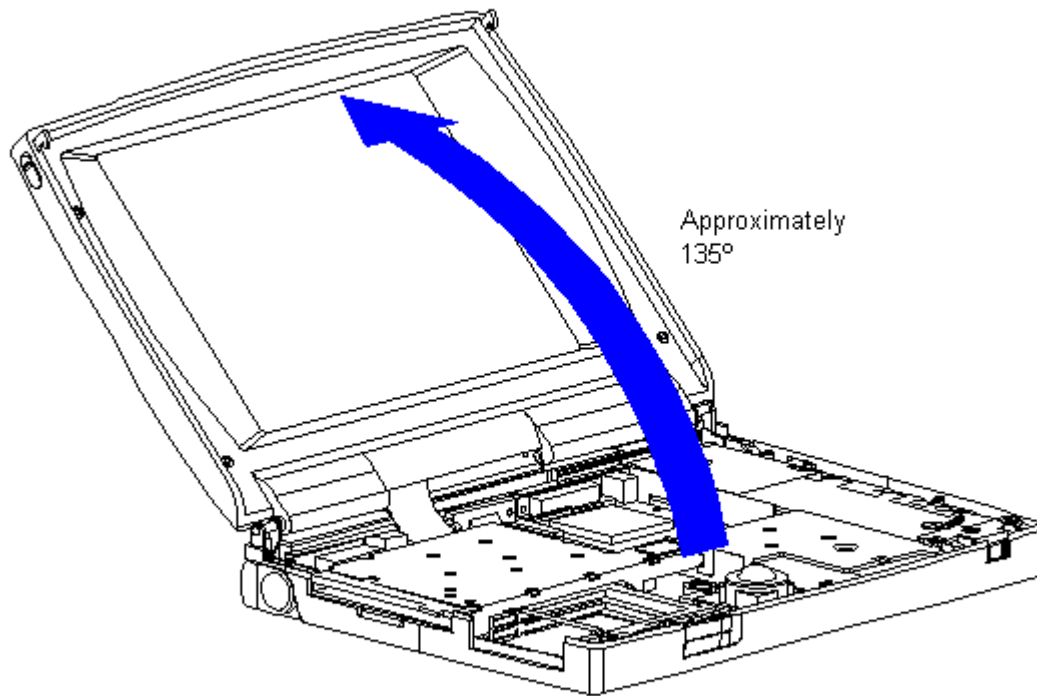

Figure 3-28. Opening the Display to a 135-degree Angle (All Models)

2. Angle the front end of the keyboard assembly into place at the front edge of the system unit module.
3. Ensure that the front plastic seams of the keyboard assembly and the front of the system unit module are aligned and flush with each other.
4. Carefully lower the rear of the keyboard assembly to the system unit module and press the outside rear corners until the keyboard assembly snaps into place.
5. Verify the alignment of the keyboard assembly to the computer base. Check the seams between the front and side edges of the computer base and the keyboard assembly. If the seam is uneven, remove the keyboard assembly and correctly align the tabs and recesses.
6. Press firmly in the center of the keyboard assembly below the status panel [1] to connect the keyboard connector [2] to the system board [3] (Figure 3-29).

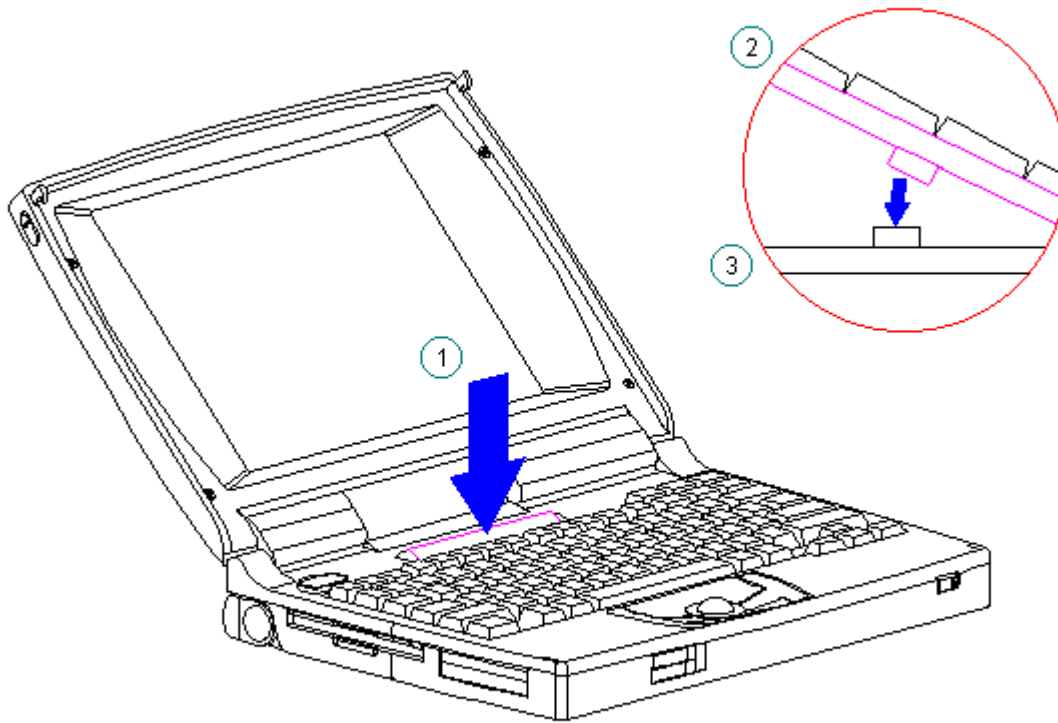

Figure 3-29. Connecting the Keyboard Assembly Connector (All Models)

Chapter 3.8 Battery Compartment Components

This section contains removal procedures for the following battery compartment components:

- o Battery compartment
- o Anti-skid pad
- o Battery release button spring
- o Battery release button

Removing the Battery Compartment

To remove the battery compartment components, follow these steps:

1. Disconnect all power from the computer and remove the AC Adapter and battery pack (Section 3.2).
2. Turn the computer top-side down.
3. Gently squeeze in the sides of the compartment, rocking it back and

forth, then lifting it up from the bottom of the base (Figure 3-30).

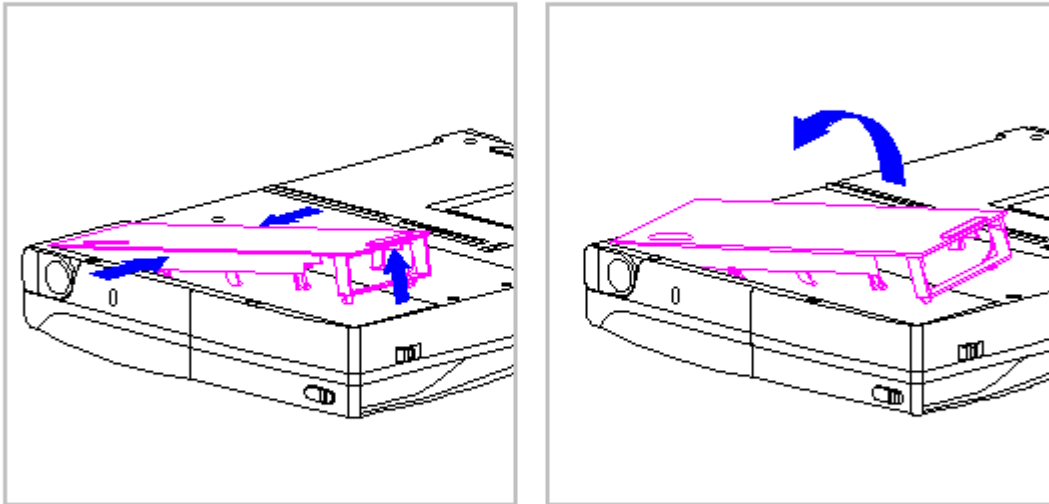

Figure 3-30. Removing the Battery Compartment (All Models)

4. To replace the battery compartment, reverse the previous steps.

Attaching the Anti-Skid Pads

If installing a new battery compartment, two anti-skid pads must be attached to the bottom of the battery compartment. To attach the anti-skid pads, follow these steps:

1. Peel off the top layer of one of the anti-skid pads to expose the adhesive.
2. With the adhesive-side down, place the anti-skid pad into the raised oval outline on the battery compartment (Figure 3-31).

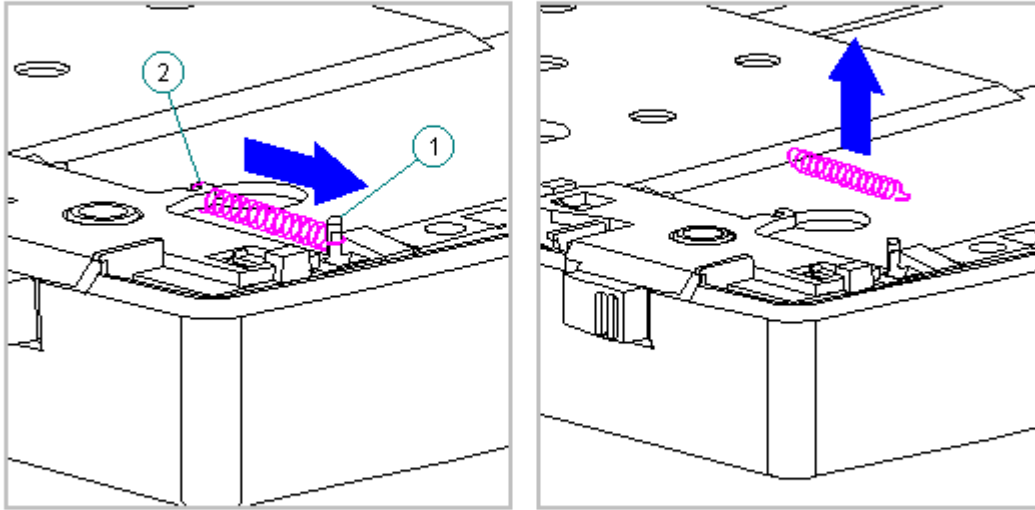

Figure 3-32. Removing the Battery Release Button Spring (All Models)

4. Rotate the battery release button counterclockwise, until it bows slightly, and lift it up to clear the hook on the computer base (Figure 3-33).

2. Remove the keyboard assembly (Section 3.7).
3. Using a Torx T-8 or flat-bladed screwdriver, remove the screw from the front right-hand corner of the integrated mechanical trackball assembly (Figure 3-37).

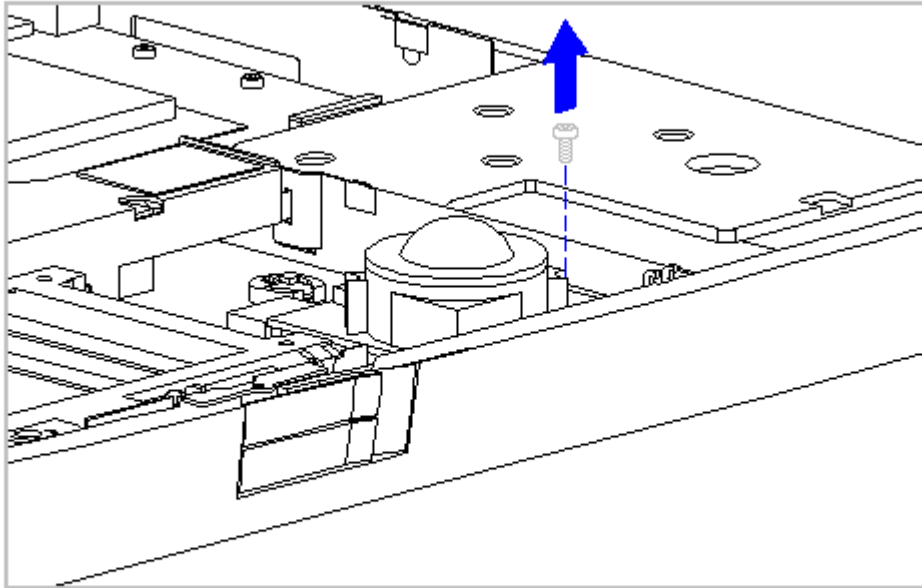

Figure 3-37. Removing the Screw from the Integrated Mechanical Trackball Assembly (Models 400 and 410)

4. Disconnect the integrated mechanical trackball assembly from the system board by pulling forward on the integrated mechanical trackball assembly until it stops.
5. Tilt up the front of the integrated mechanical trackball assembly and lift it up to clear the connectors and the system board (Figure 3-38).

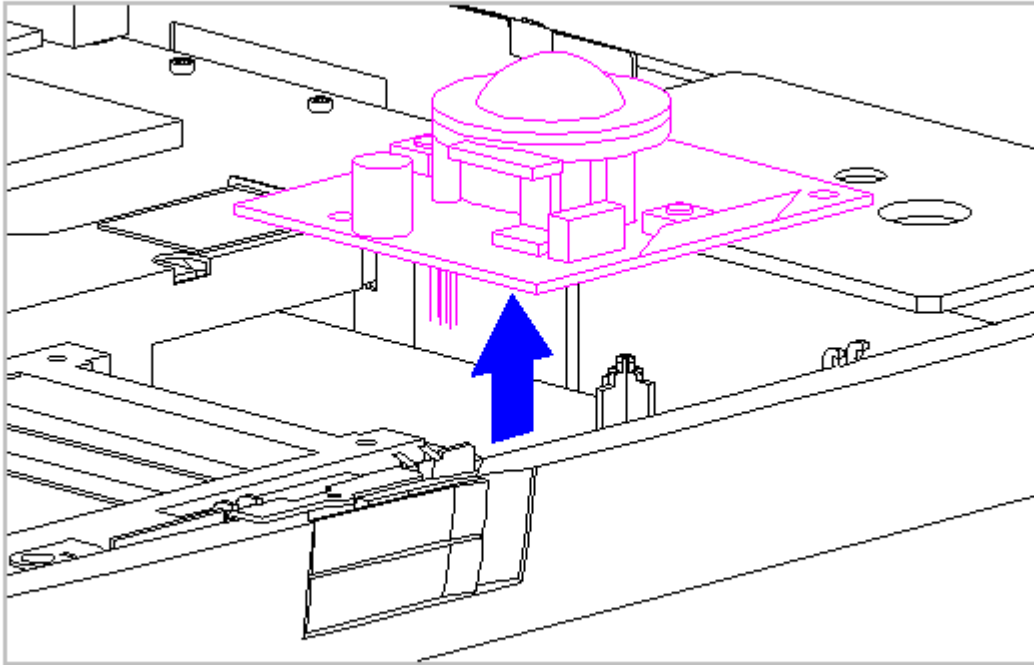

Figure 3-40. Disconnecting the Optical Trackball Assembly from the System Board (Models 420 and 430)

5. To replace the integrated mechanical trackball assembly, reverse the previous steps.

Trackball Cleaning Procedures

1. Turn off the computer, disconnect AC power, and remove the battery pack.
2. Remove the Integrated trackball.
3. Remove any large particles of debris that have fallen into the trackball housing.
4. Dip a cotton swab in isopropyl alcohol and squeeze off excess liquid.
5. Carefully wipe inside the cage to remove residue from surfaces. Clean the ball bearings by rubbing with the swab. Do not attempt to remove the bearings. Do not use alcohol on the sensor window. Instead, gently wipe the sensor window with a soft, dry, lint-free cloth until all debris is removed. Allow enough time for the parts to air dry before reassembling.
6. Replace the ball and gently secure the retaining ring by rotating it clockwise.

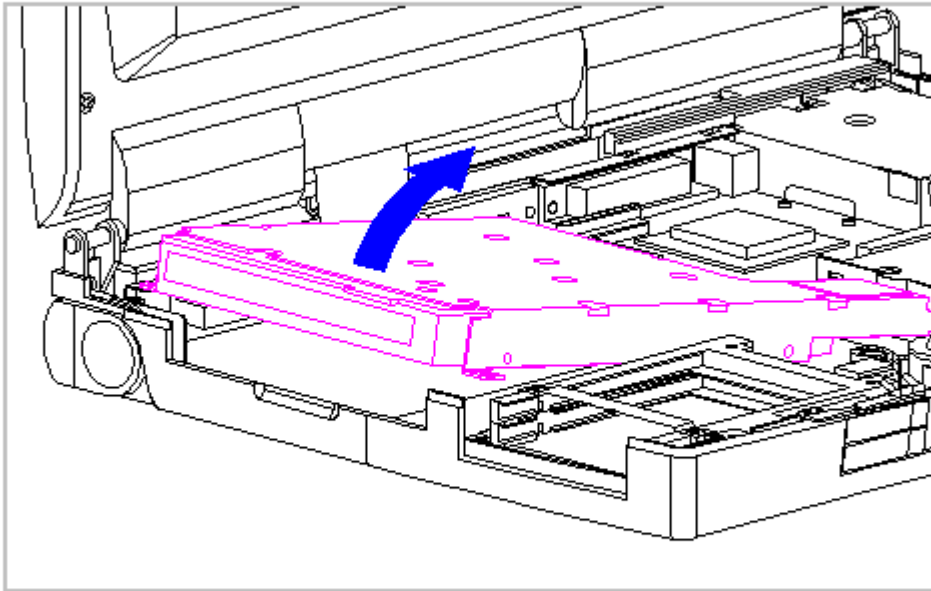

Figure 3-43. Removing the Diskette Drive from the System Chassis (All Models)

Removing the Diskette Drive from the Diskette Drive Bracket

1. Remove the diskette drive from the system chassis. Refer to "Removing the Diskette Drive" in this section.
2. Remove the diskette drive from the bracket by removing the four screws from both sides of the bracket (Figure 3-44).

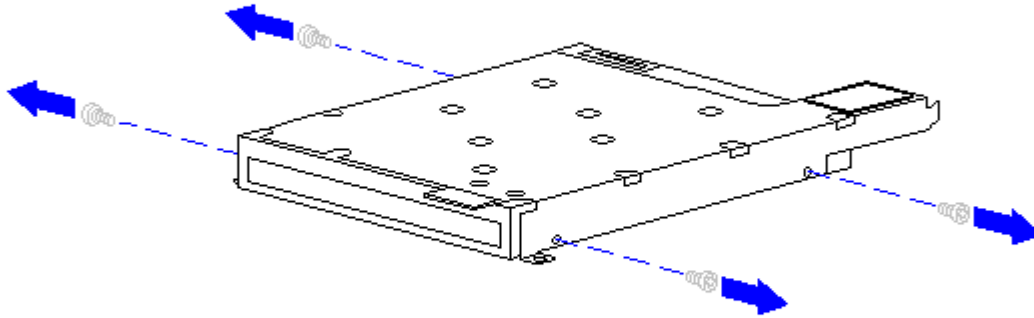

Figure 3-44. Removing the Diskette Drive Bracket Screws (All Models)

3. Separate the diskette drive from the bracket (Figure 3-45).

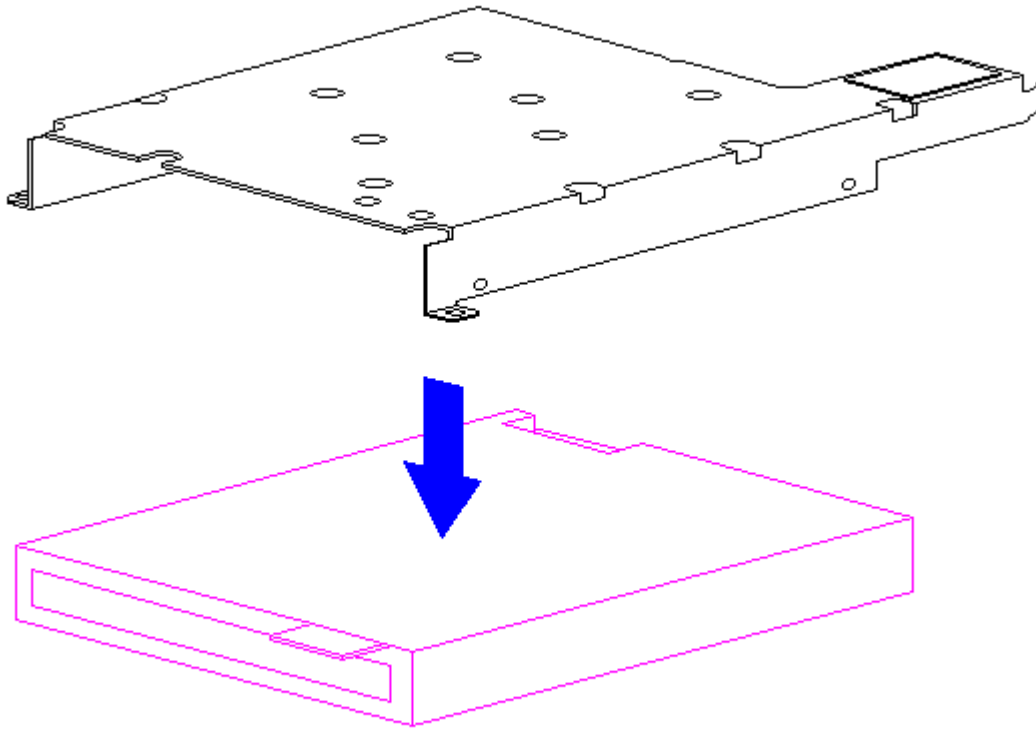

Figure 3-45. Removing the Diskette Drive (All Models)

4. To replace the diskette drive into the bracket, reverse the previous steps.

Applying the Diskette Drive Hook and Loop Fastener

If installing a new diskette drive bracket, the hook and loop fastener must be attached to the bracket.

To attach the hook and loop fastener, follow these steps:

1. Separate the new hook and loop fastener.
2. Remove the backing from the adhesive on the hook and loop fastener that is the opposite color of the hook and loop fastener attached to the keyboard assembly (for example, white to black or black to white).
3. Attach the new hook and loop fastener of the opposite color of the hook and loop fastener on the keyboard assembly to the tab on the diskette drive bracket (Figure 3-46).

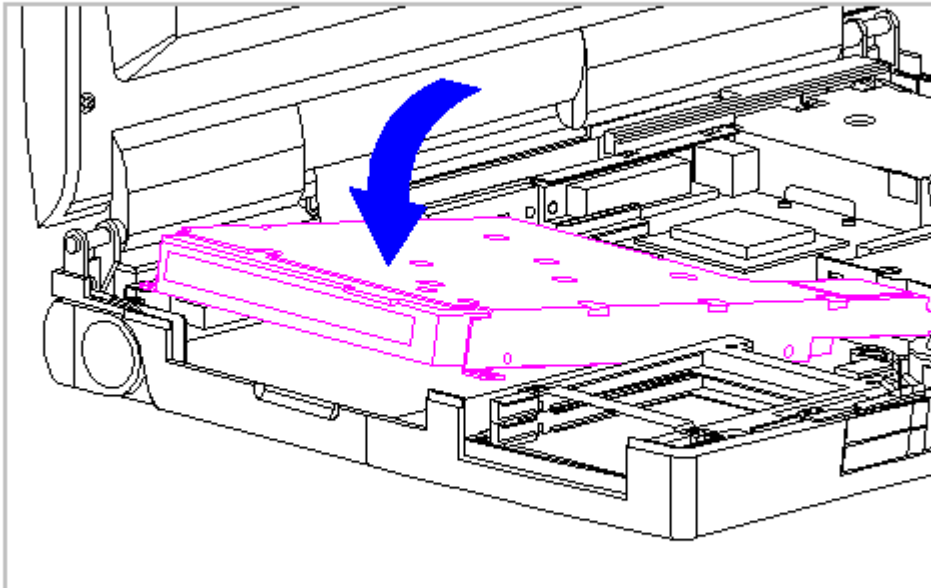

Figure 3-47. Replacing the Diskette Drive (All Models)

4. Reconnect the Diskette Drive Cable and reinstall the three screws.

Chapter 3.15 The System Board (All Models)

To remove the system board, follow these steps:

1. Disconnect all power from the computer and remove the AC Adapter and battery pack (Section 3.2).
2. Remove the hard drive (Section 3.5).
3. Remove the memory expansion board, if installed (Section 3.6).
4. On the rear of the computer, use a hex socket driver to remove the six screw locks (Figure 3-48).
5. Using a Torx-T8 driver, remove the two alignment screws from the docking base connector (Figure 3-48).

10. Disconnect the display cable from the system board by pulling up both ends of the ZIF connector slide simultaneously [1], carefully opening the slide [2] (Figure 3-49).
11. Lift the display cable out of the connector slide [3], being careful not to pull or twist the cable (Figure 3-49).

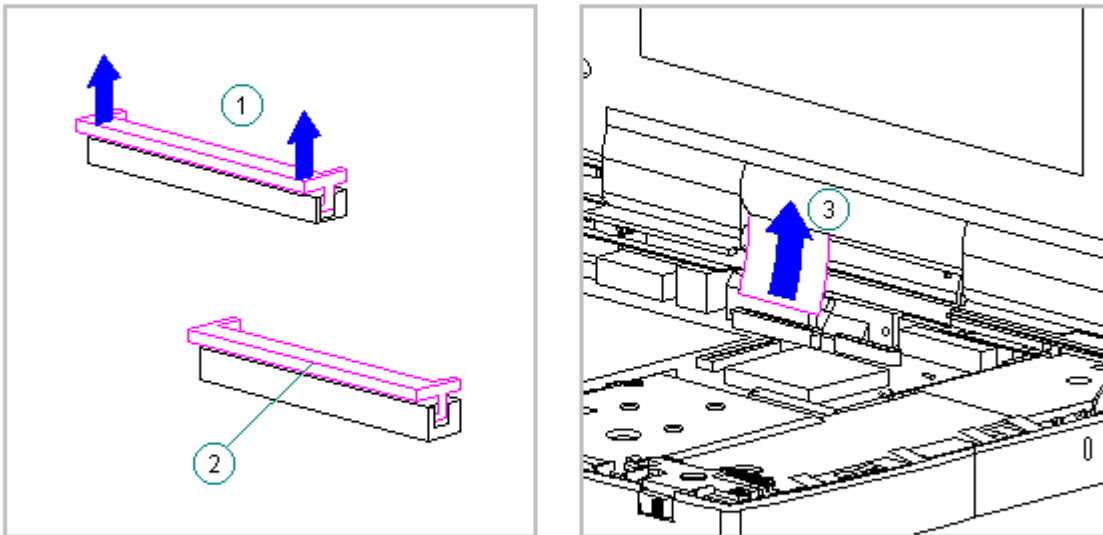

Figure 3-49. Removing the Display Cable from the System Board (All Models)

12. Disconnect the display ground cable [1] from the LIF clip above the serial port connector (Figure 3-50).

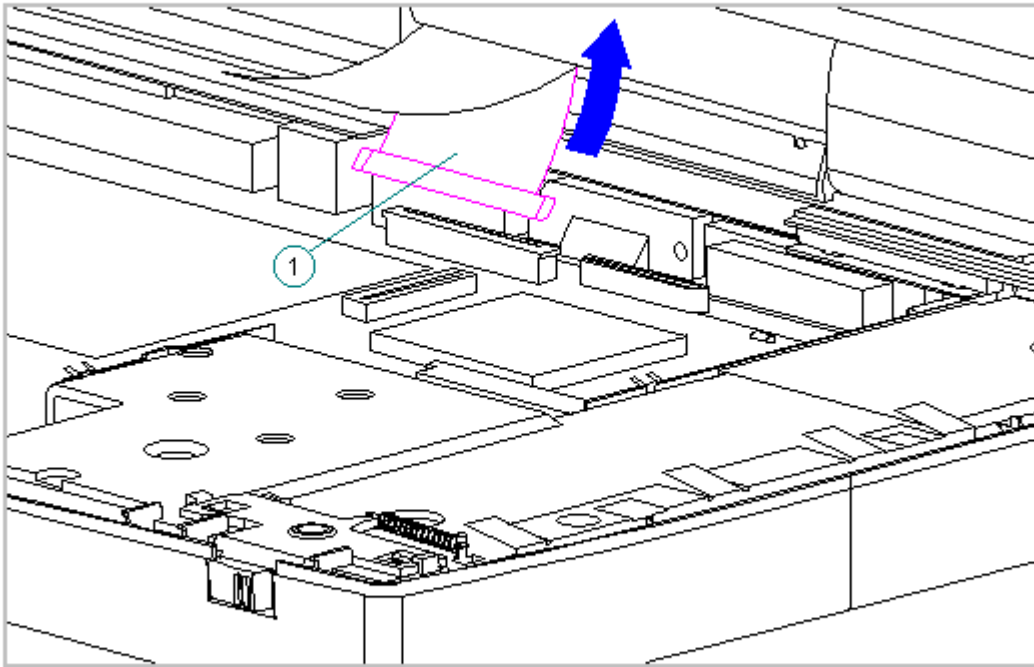

Figure 3-50. Disconnecting the Display Ground Cable (All Models)

13. Remove the three keyboard ground clips from the system board (Figure 3-51).

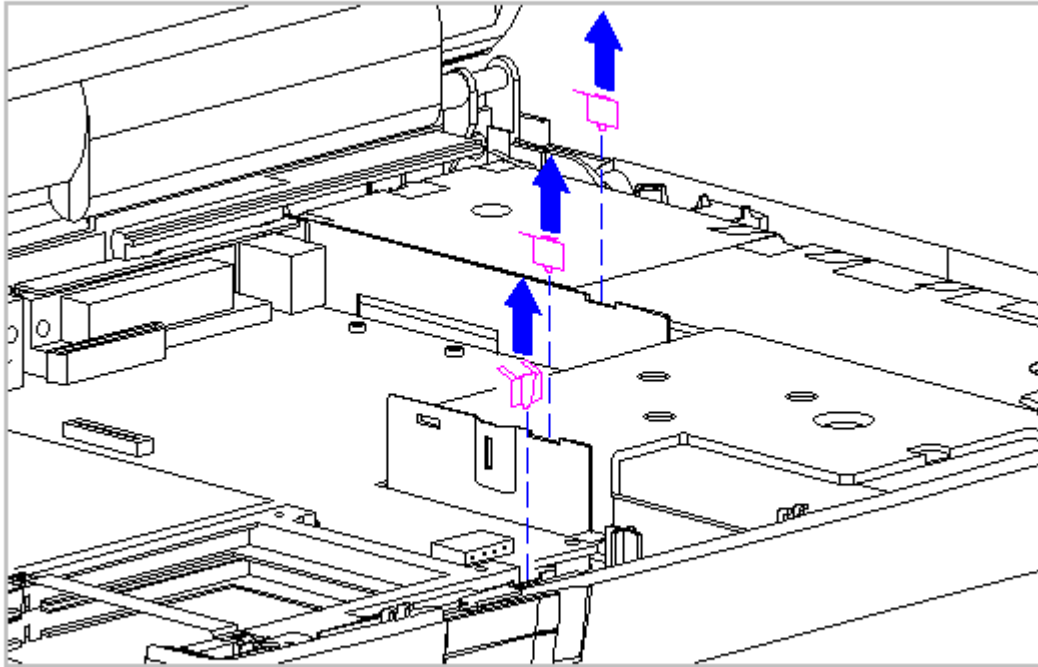

Figure 3-51. Removing the Keyboard Ground Clips from the System Board

14. Remove the left clutch ground clip from the system chassis (Figure 3-52).

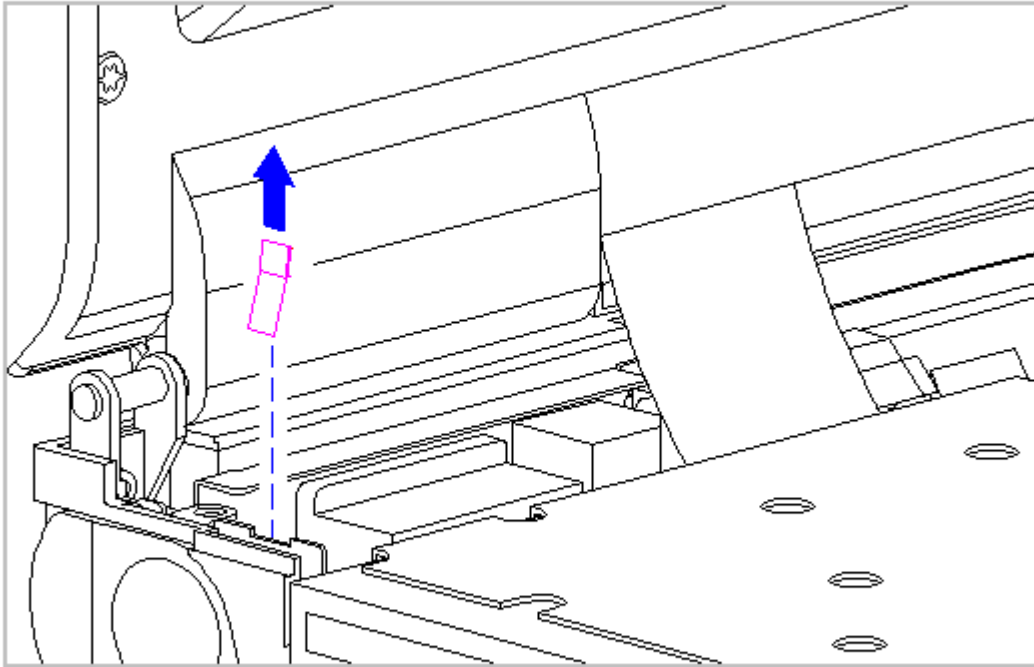

Figure 3-52. Removing the Left Clutch Ground Clip (All Models)

15. For Models 400 and 410, using a Torx T8 or slotted driver, remove the five screws from the system board and the two screws from the battery contact (Figure 3-53).

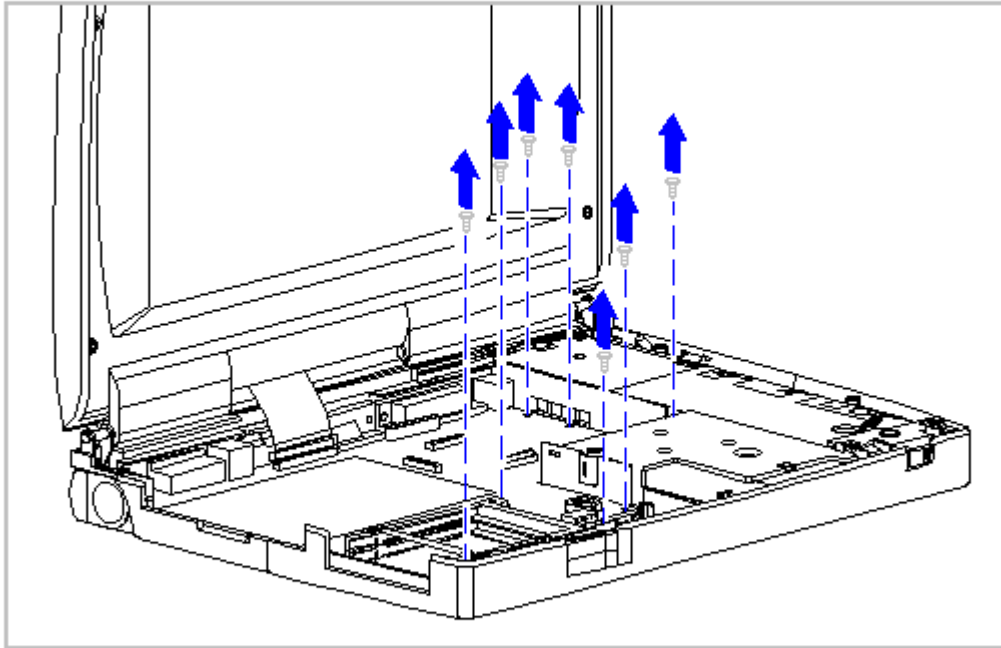

Figure 3-53. Removing the Five System Board and the Two Battery Contact Screws (Models 400 and 410)

16. For Models 420 and 430, using a Torx T8 or slotted driver, remove the four screws from the system board and the two screws from the battery contact (Figure 3-54).

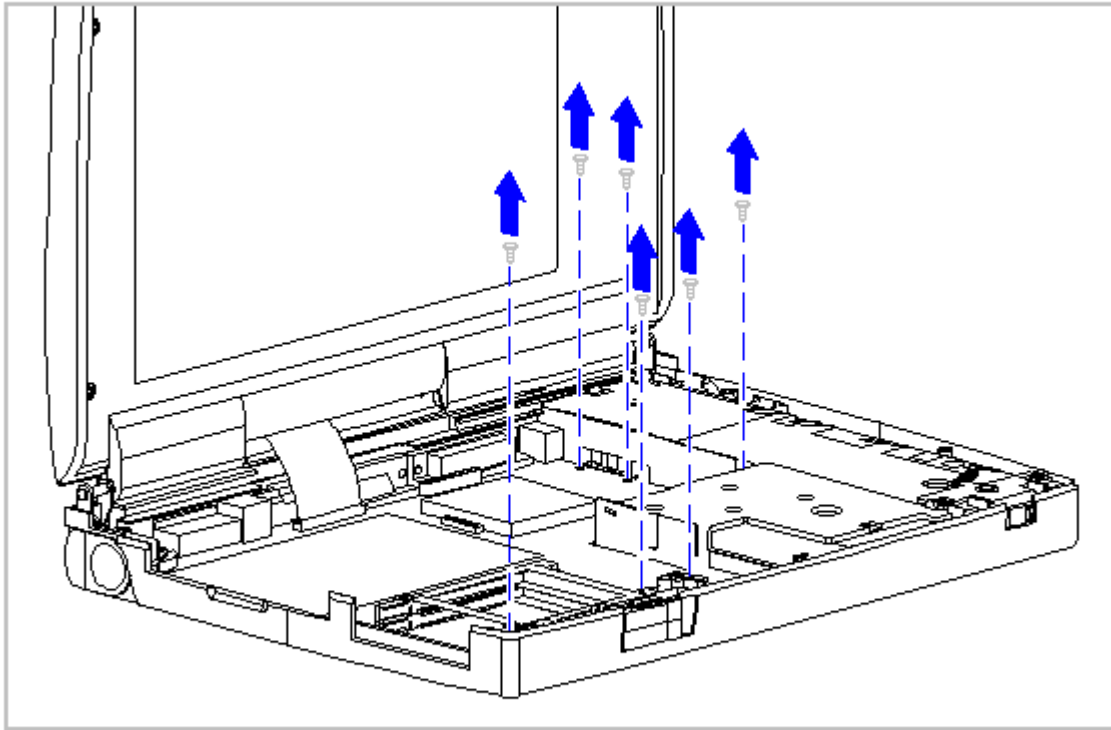

Figure 3-54. Removing the Four System Board and the Two Battery Contact Screws (Models 420 and 430)

17. From the front of the computer, tilt the system board up then lift the system board out of the system chassis (Figure 3-55).

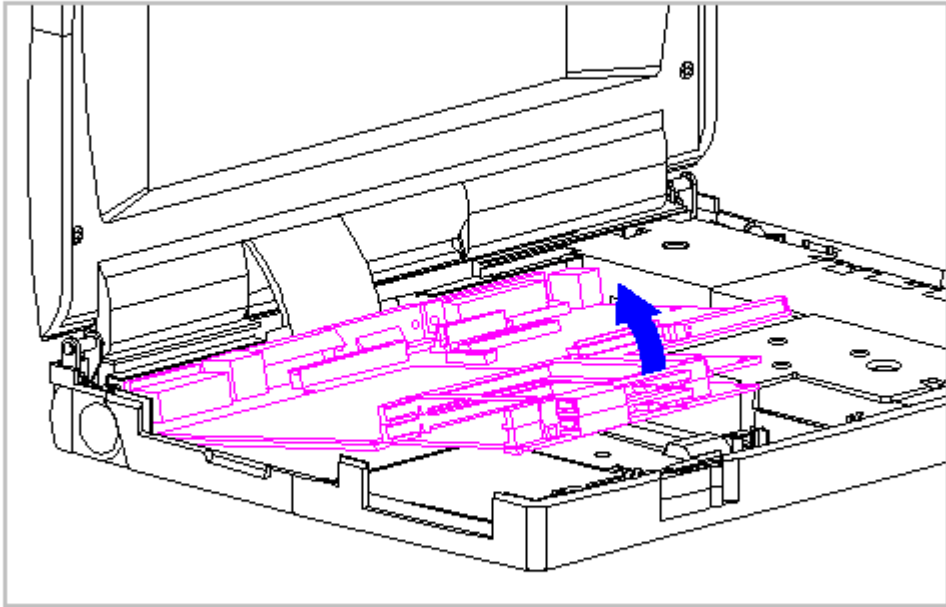

Figure 3-55. Removing the System Board (All Models)

18. Remove the LIF clip from above the serial port connector between the system board and the system chassis (Figure 3-56).

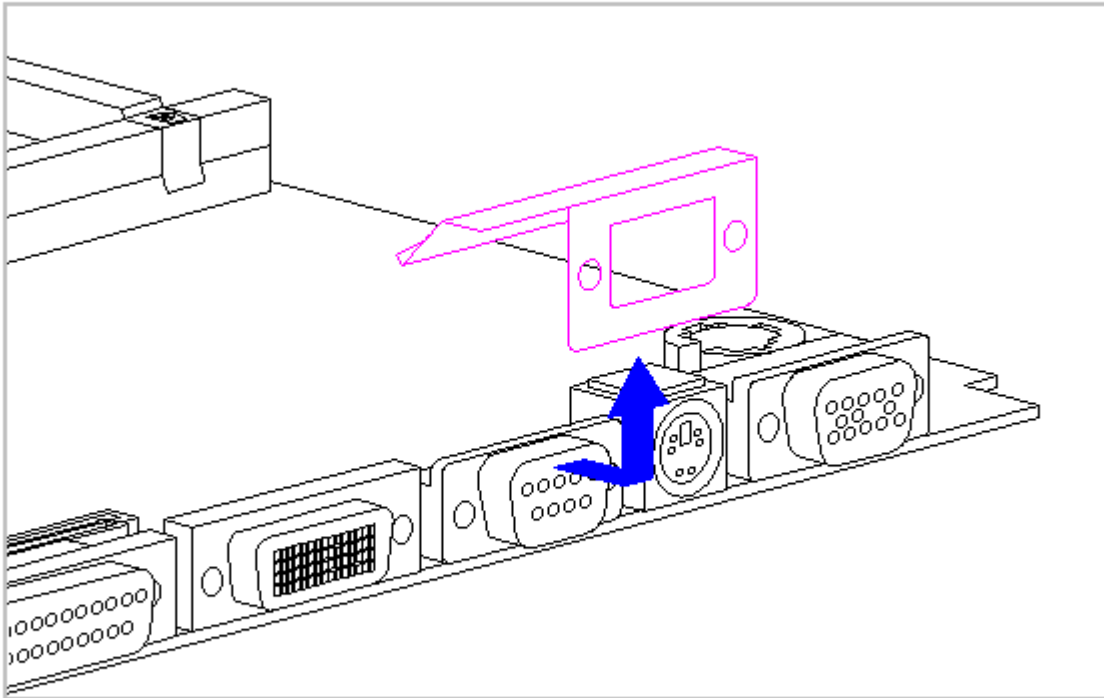

Figure 3-56. Removing the LIF Clip (All Models)

19. To replace the system board, reverse the previous steps.

To replace the System Board, follow these steps:

IMPORTANT: When installing a new system board, make sure that the insulator is placed between the system board and the diskette drive. The gasket over the Keyboard connector must be tucked under the Chassis.

IMPORTANT: When replacing the system board, the screws must be replaced as follows:

1. Replace the two alignment screws on the rear of the system unit module to align the system board (Figure 3-57).

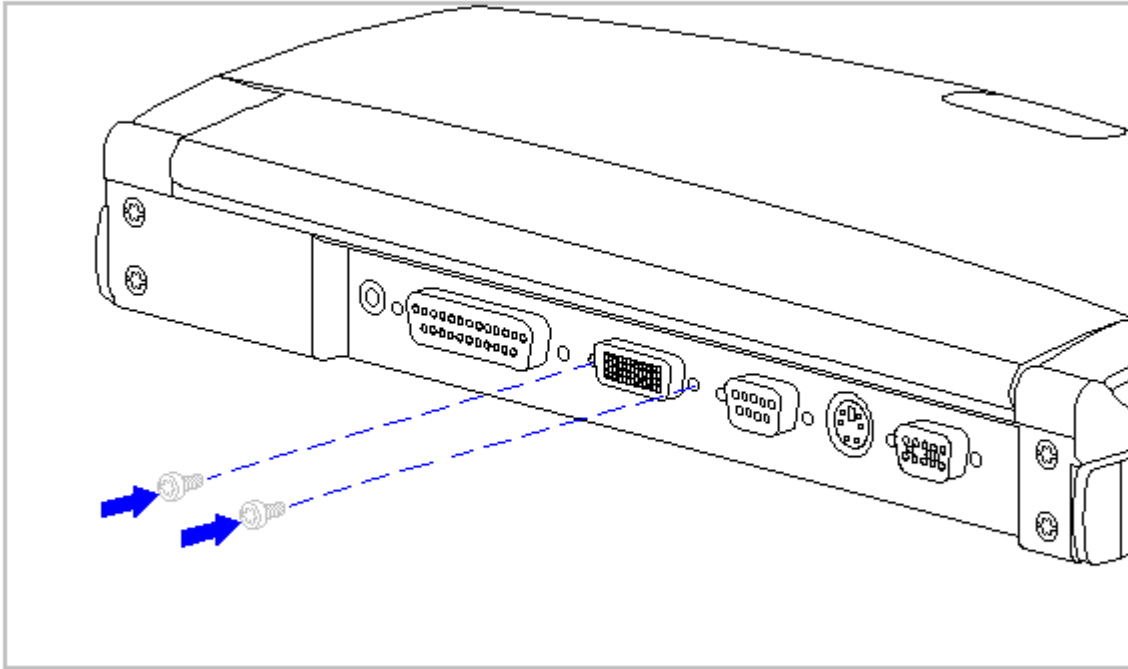

Figure 3-57. Replacing the Alignment Screws (All Models)

2. Install screws [1] and [2] on the system board before replacing the remaining system board and battery contact screws for Models 400 and 410 (Figure 3-58) and for Models 420 and 430 (Figure 3-59).

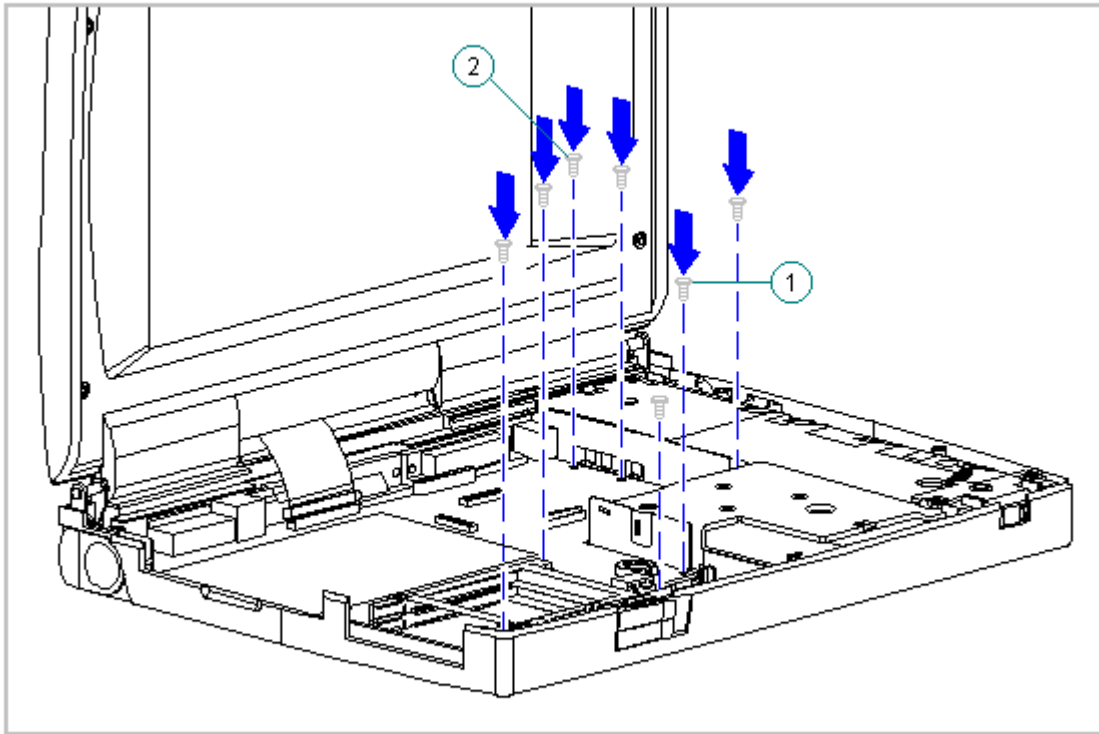

Figure 3-58. Replacing the Five System Board Screws and Two Battery Contact Screws (Models 400 and 410)

rails are assembled properly into the PC Card Header. The rail goes under the edge of the header. Tighten the header screws from the bottom of the system board.

Removing the PC Card (PCMCIA) Rails

NOTE: The rails for the 400 and 410 models are not interchangeable with the rails for the 420 and 430 models.

To remove the PC Card rails, follow these steps.

1. Remove the PC Card clips. Refer to "Removing the PC Card Clip" in this section.
2. Slide the rails out of the header (Figure 3-61).

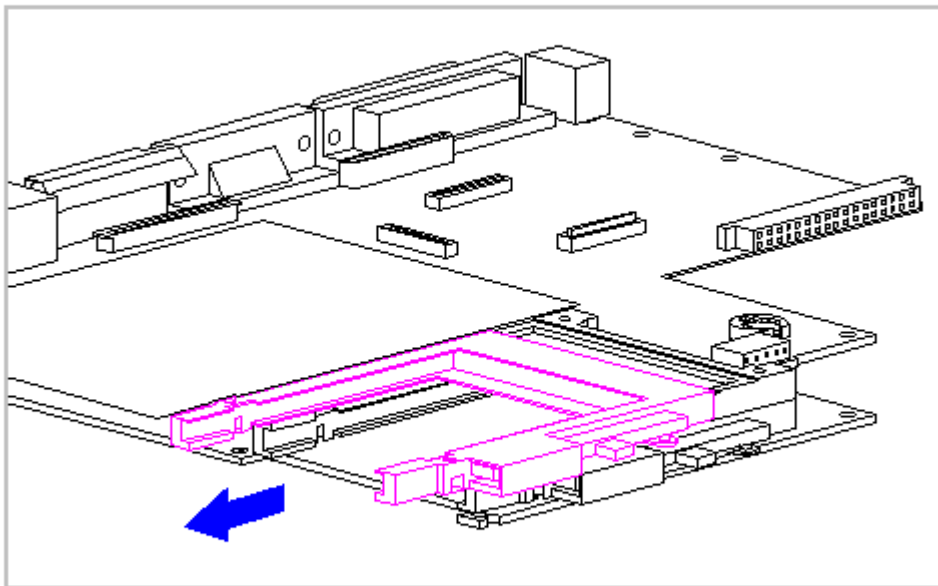

Figure 3-61. Removing the PC Card Rails from the Header (All Models)

3. To replace the PC Card rails, reverse the previous steps. The PC Card rails go under the edge of the Header.

Chapter 3.17 PC Card (PCMCIA) Ejection Levers and Pin

This section contains removal and replacement procedures for the PC Card ejection levers and pin.

To remove the PC Card ejection levers and pin, follow these steps:

1. Disconnect all power from the computer and remove the AC Adapter and battery pack (Section 3.2).
2. Remove the PC Card ejection lever pin from the system chassis (Figure 3-62).

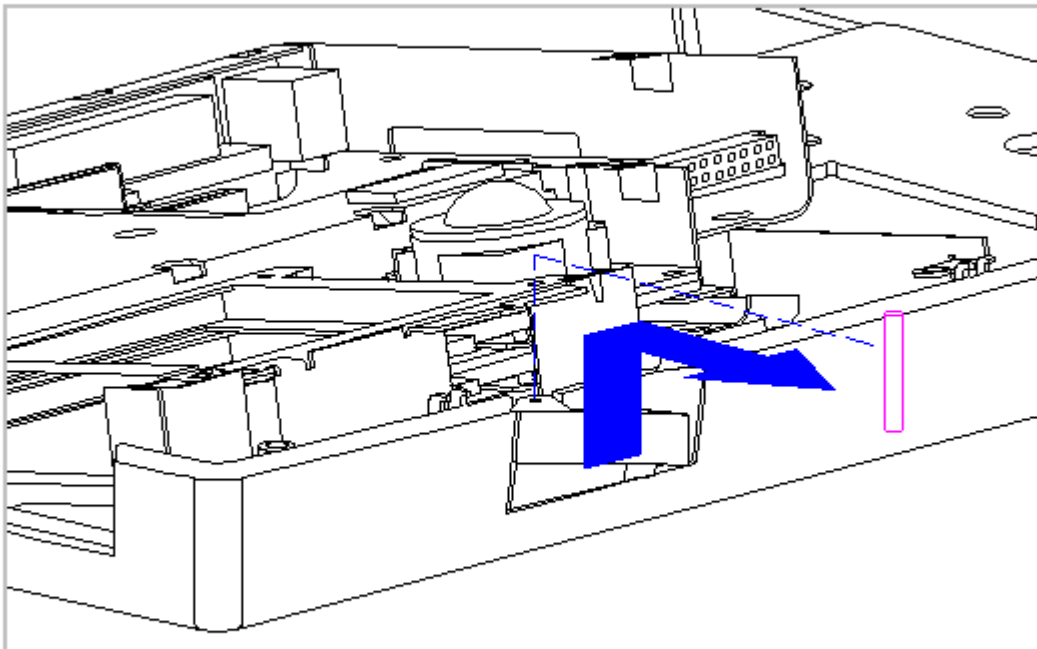

Figure 3-62. Remove the PC Card Ejection Lever Pin (All Models)

3. Remove the top PC Card (PCMCIA) ejection lever (Figure 3-63).

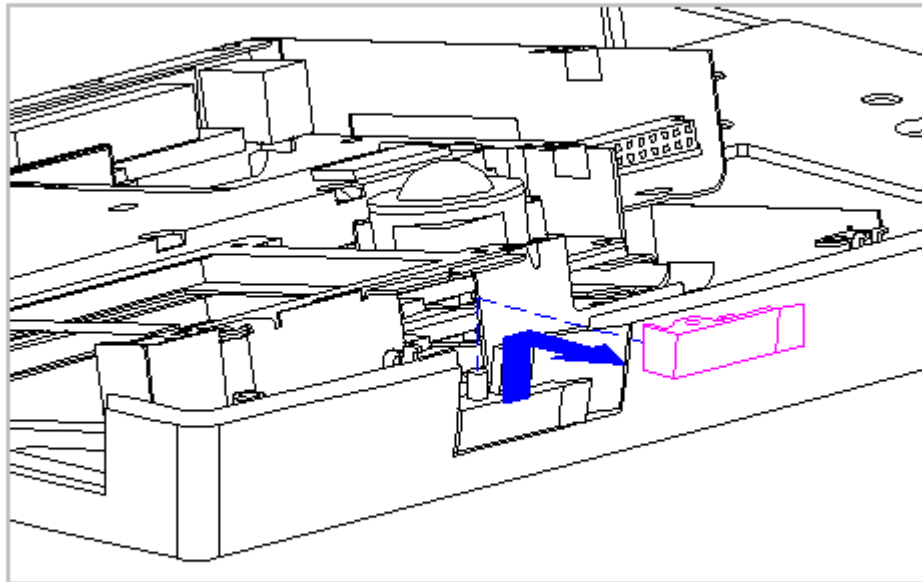

Figure 3-63. Removing the Top PC Card Ejection Lever (All Models)

4. Remove the bottom PC Card ejection lever from the boss on the CPU base (Figure 3-64)

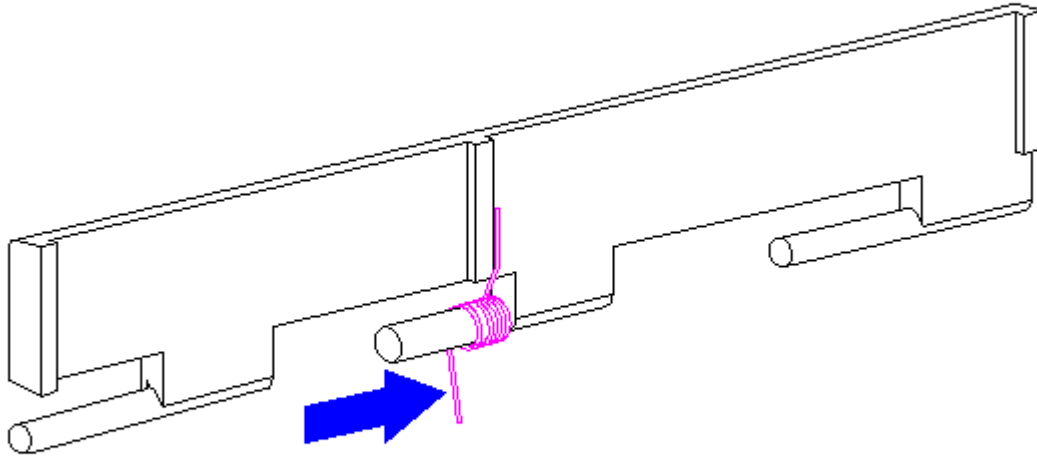

Figure 3-66. Replacing the PC Card Spring (All Models)

2. Install the PC Card door, making sure the spring is placed between the notch [1] and the rib [2] (Figure 3-67).

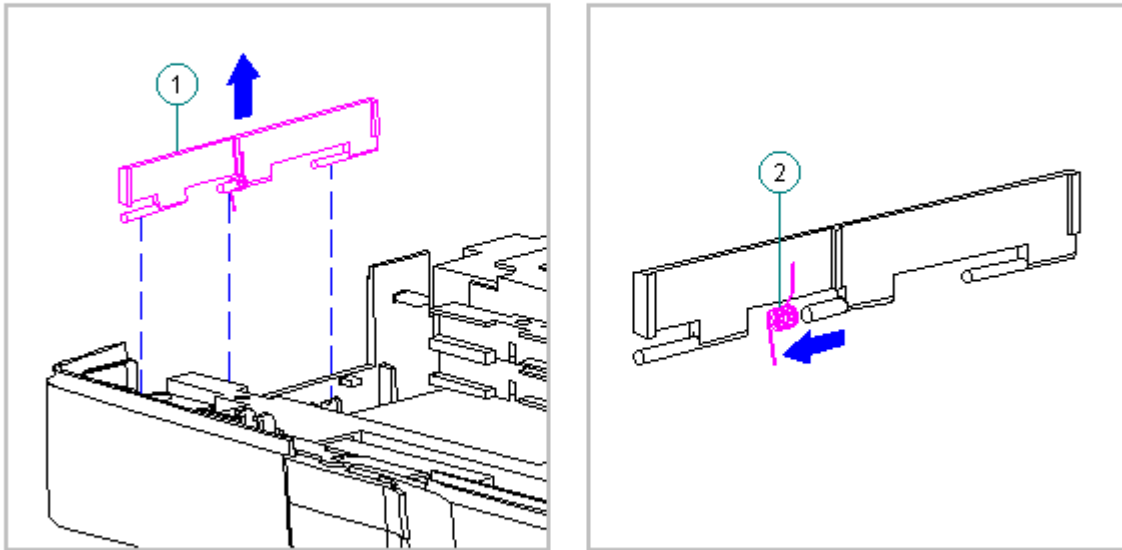

Figure 3-68. Removing the Bottom PC Card Door and Spring (All Models)

To replace the bottom PC Card (PCMCIA) spring and door, follow these steps:

1. Install the PC Card spring on the door post, making sure the bent arm of the spring is placed against the rib on the PC Card door (Figure 3-69).

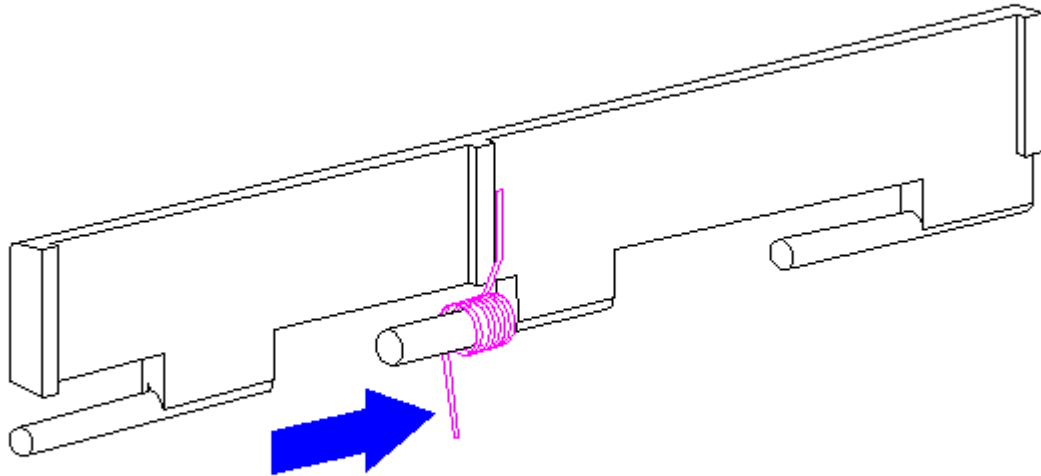

Figure 3-69. Replacing the PC Card Spring (All Models)

2. Install the PC Card door, making sure the spring is placed between the notch [1] and the rib [2] (Figure 3-70).

7. Remove the four clutch screws from the rear of the system unit module (Figure 3-71).

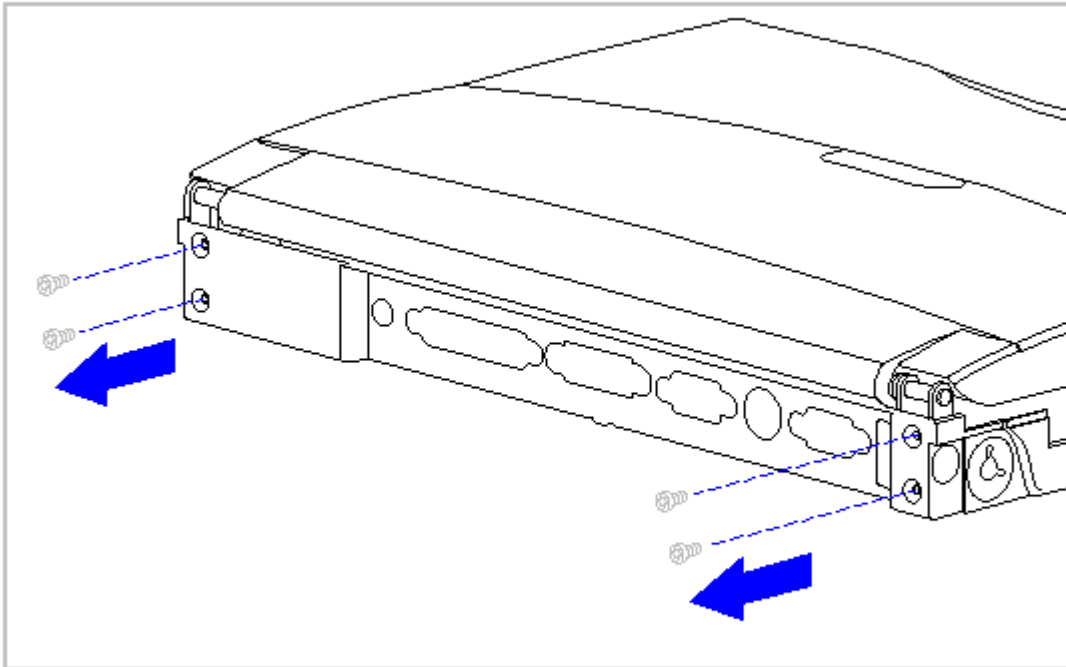

Figure 3-71. Removing the Rear Clutch Screws (All Models)

8. Remove the display assembly from the system unit module (Figure 3-72).

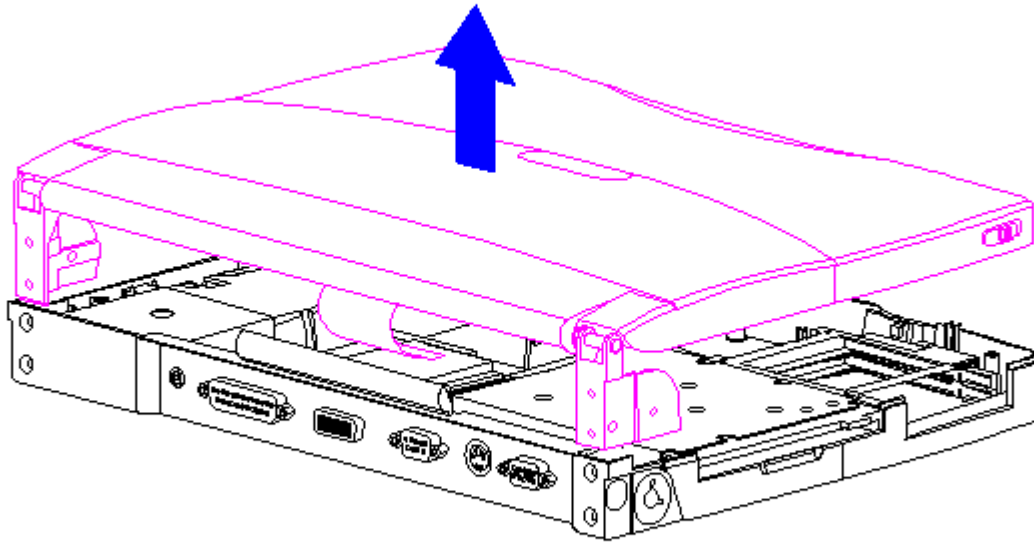

Figure 3-72. Removing the Display Assembly (All Models)

9. Slide the trough at the rear of the CPU base to the right, then lift up to remove (Figure 3-73).

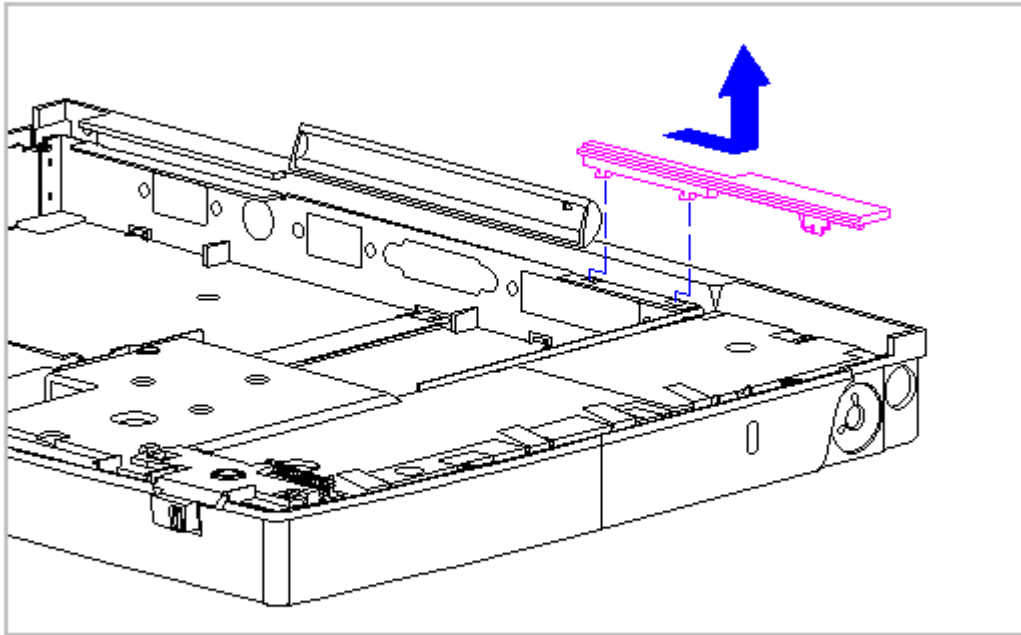

Figure 3-73. Removing the Trough from the CPU Base (All Models)

10. Remove the system chassis by gently separating it from the CPU base and lifting out the system chassis (Figure 3-74).

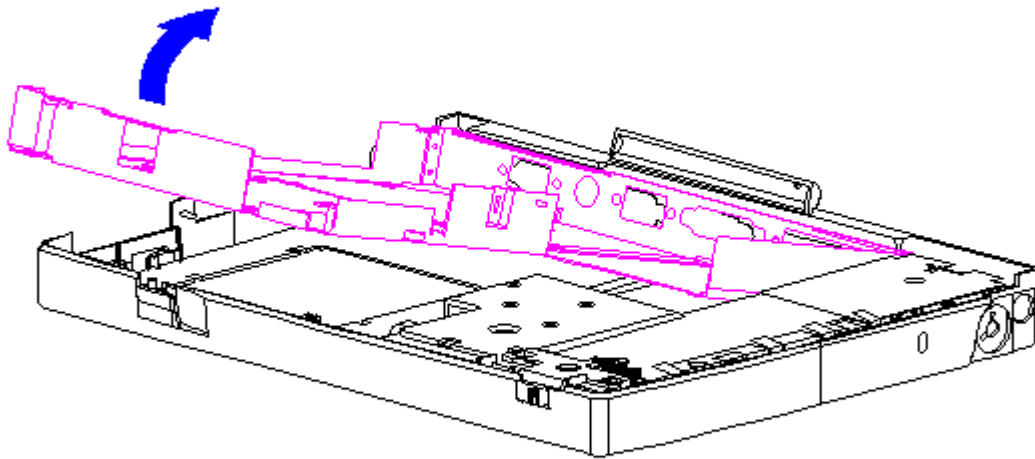

Figure 3-74. Removing the System Chassis (All Models)

11. To replace the system chassis, reverse the previous steps.

Chapter 3.20 CPU Base (All Models)

This section provides removal and replacement procedures for the following CPU base components:

- o Battery shield clip
- o Lock provision plate
- o Anti-skid pads

Removing and Replacing the Battery Shield Clip

To remove the battery shield clip, follow these steps:

1. Disconnect all power from the computer and remove the AC Adapter and battery pack (Section 3.2).

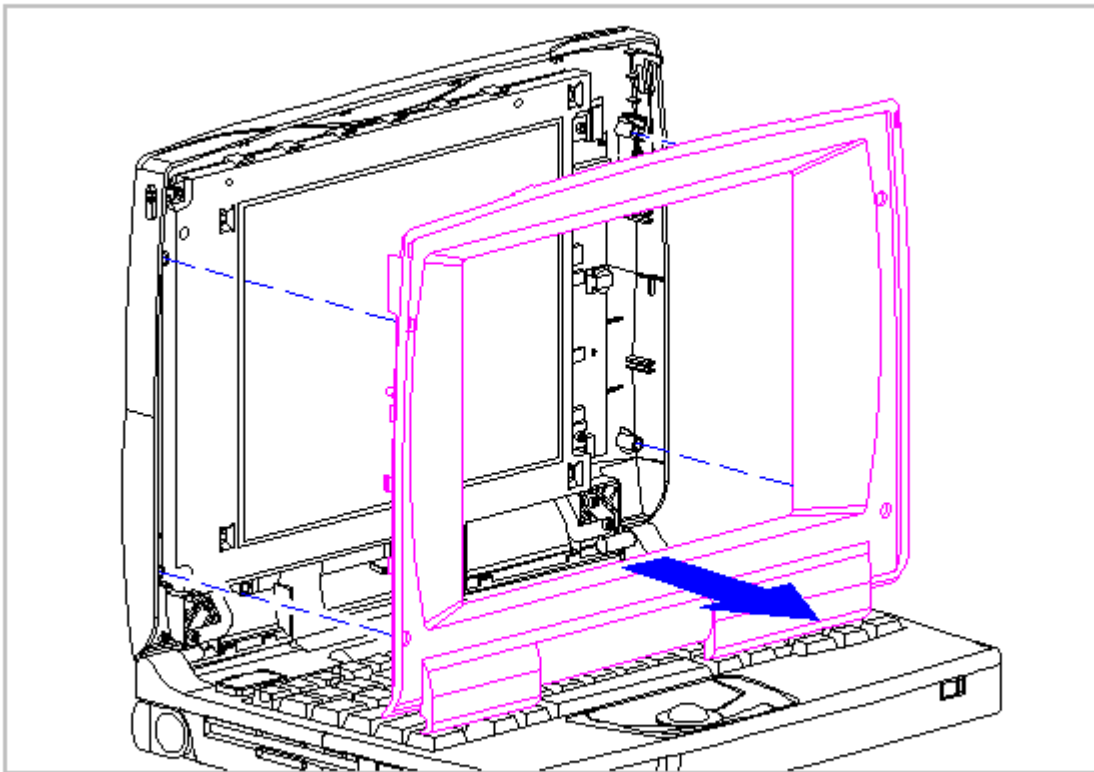

Figure 3-79. Removing the Display Bezel (Models 400 and 410)

5. To replace the bezel, reverse the previous steps.

Removing the Display Enclosure Latches and Springs

To remove the display enclosure latches and springs from either side of the display enclosure, follow these steps:

1. Disconnect all power from the computer and remove the AC Adapter and battery pack (Section 3.2).
2. Open the computer.
3. Remove the display bezel. Refer to "Removing and Replacing the Display Bezel" in this section.
4. Hold the bottom of the latch near the spring. Flex the hook end of the display latch away from the display enclosure [1] (Figure 3-80).
5. Pull the display latch from the top, then out of the display enclosure [2] (Figure 3-80).

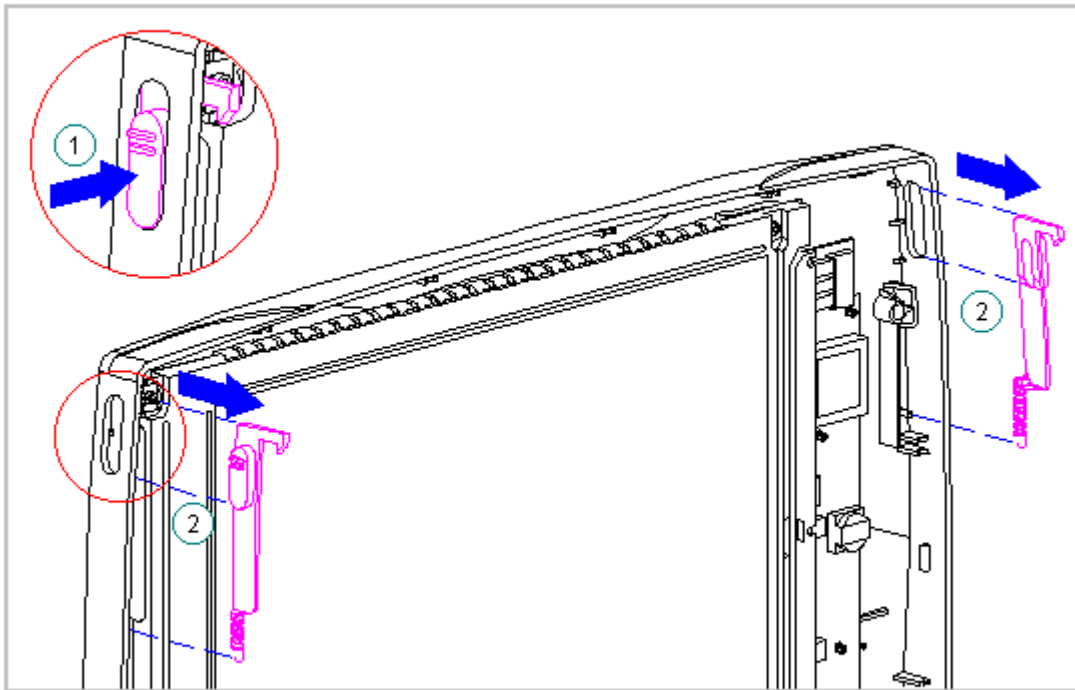

Figure 3-80. Removing the Display Latch from the Display Enclosure (All Models)

6. Remove the display latch spring from the latch (Figure 3-81).

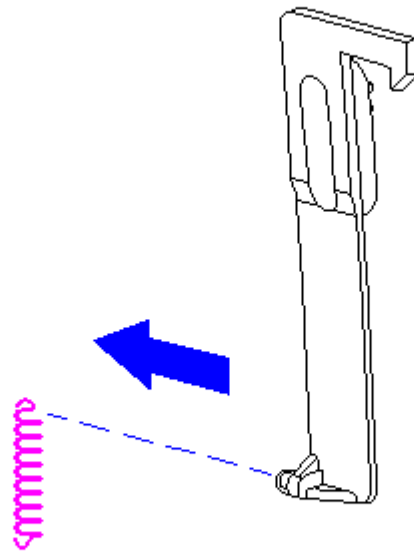

Figure 3-81. Removing the Display Latch Spring from the Latch (Models 400 and 410)

Replacing the Display Enclosure Springs and Latches

To replace the display springs and latches, follow these steps:

1. Hook the display latch spring on to the display latch [1] and place the display latch spring over the post in the display enclosure [2] (Figure 3-82).

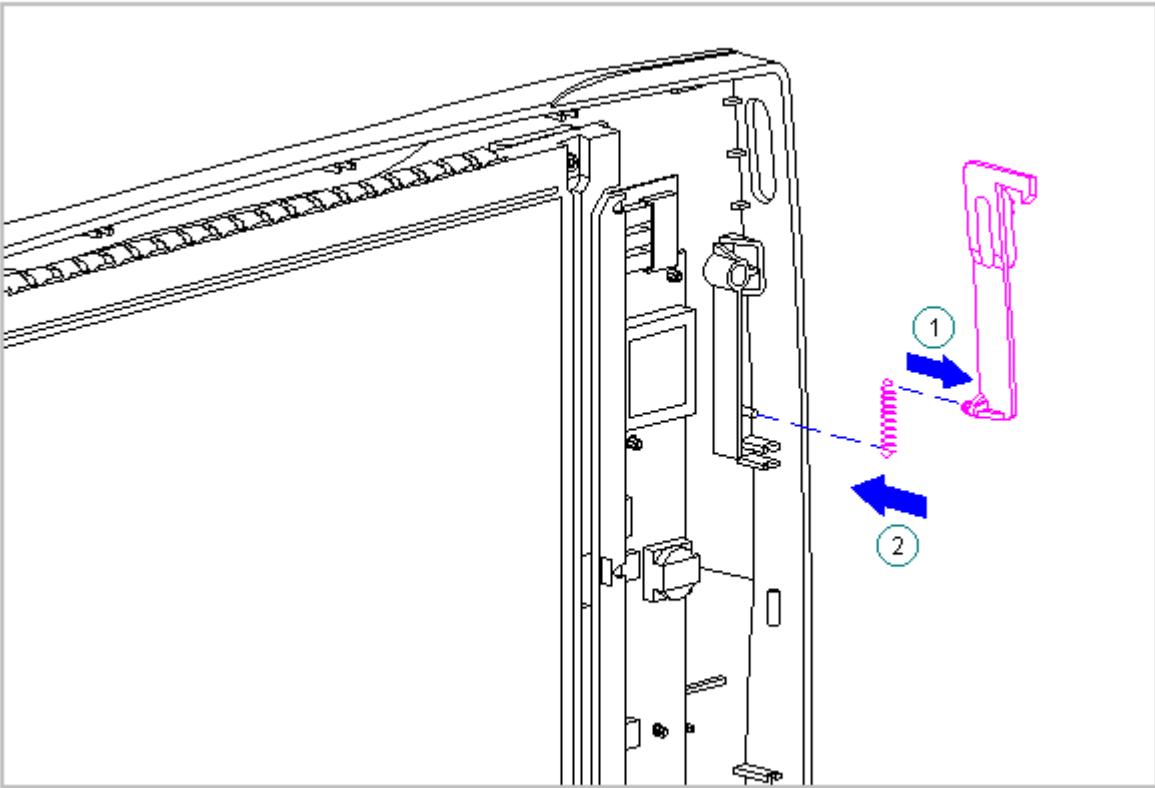

Figure 3-82. Replacing the Display Latch Spring (Models 400 and 410)

2. Slide the display latch into place on either side of the display enclosure (Figure 3-83).

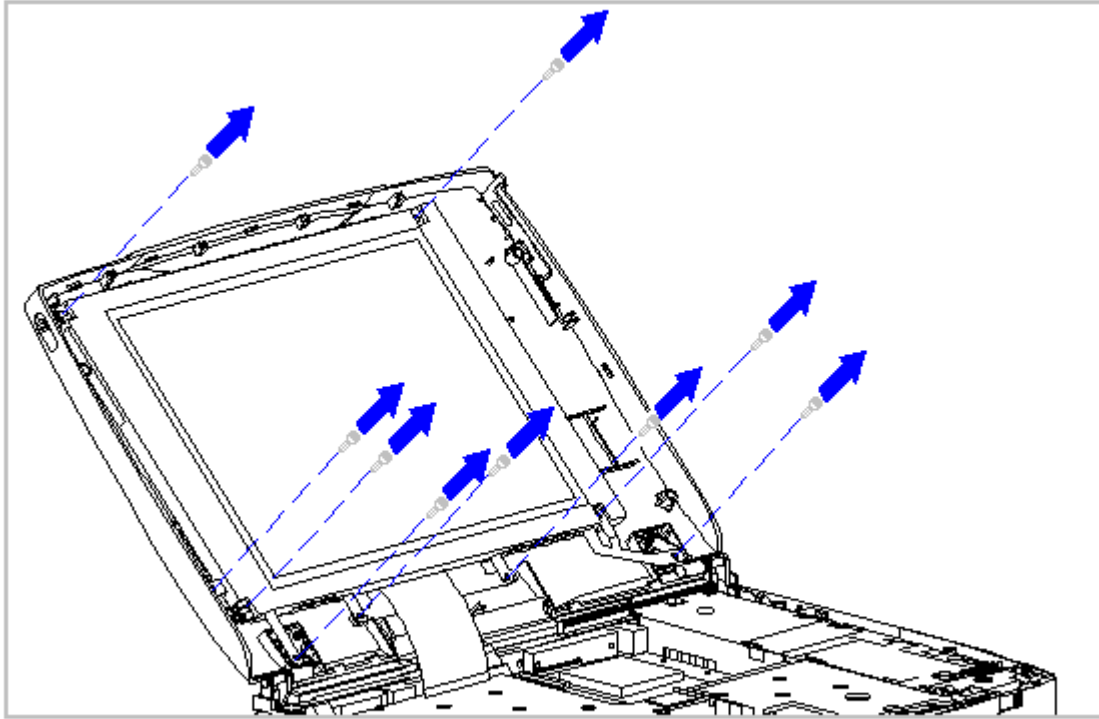

Figure 3-89. Removing the Screws from the Monochrome LCD Panel and the Shield (Models 400 and 410)

12. Carefully remove the Monochrome LCD panel, display cable, and shield from the display enclosure (Figure 3-90).

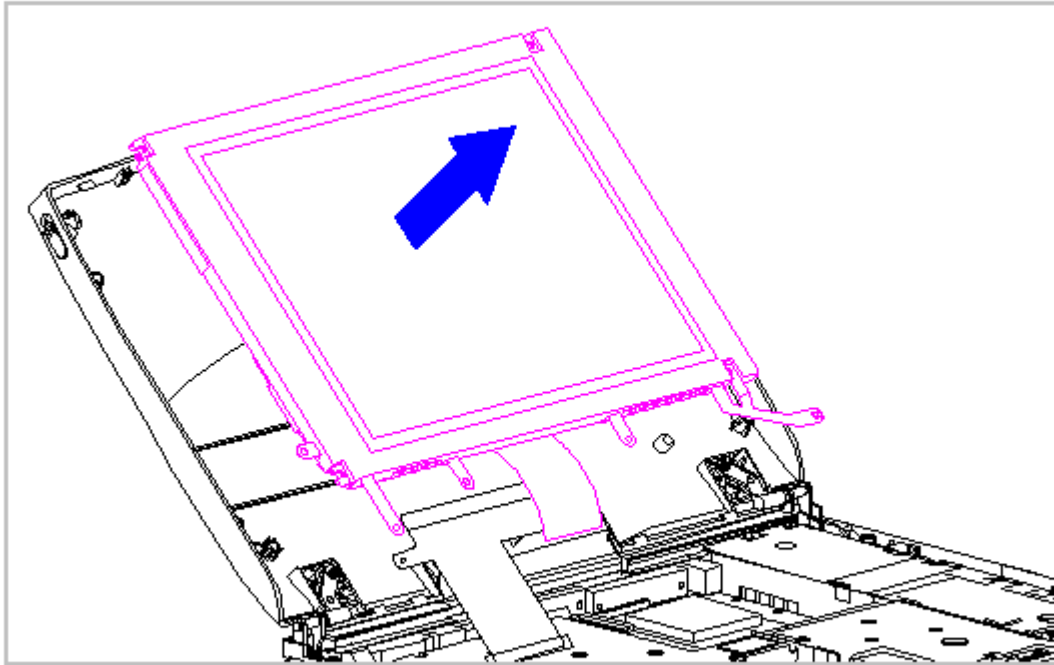

Figure 3-90. Removing the Monochrome LCD Panel and Shield (Models 400 and 410)

13. Lay the Monochrome LCD panel face down on a clean surface.
14. Grasp the sides of the shield near the backlight cable. Flex the shield away from the Monochrome LCD panel. Ensure that the shield tabs and finger grips clear the LCD panel (Figure 3-91).

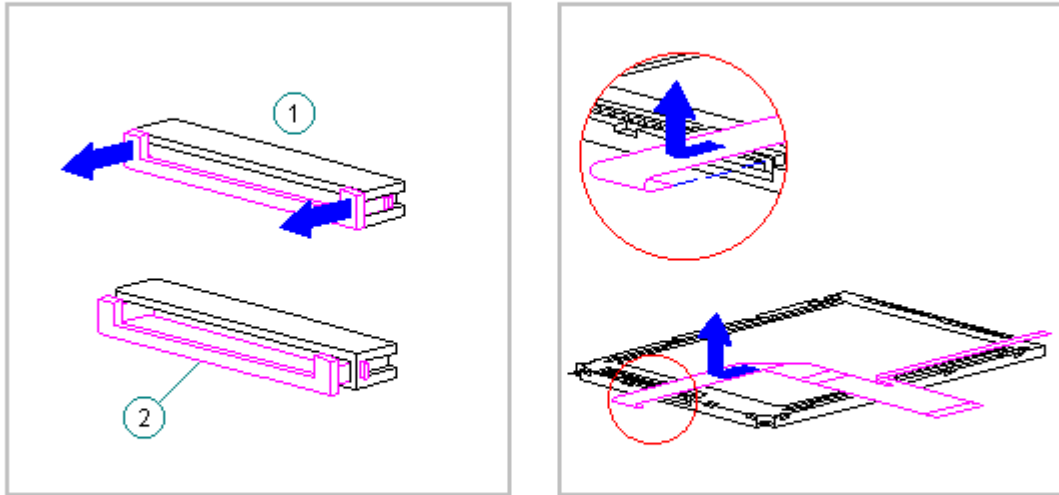

Figure 3-92. Removing the Display Cable from the Monochrome LCD Panel (Models 400 and 410)

17. Lift the display ground cable out of the display enclosure (Figure 3-93).

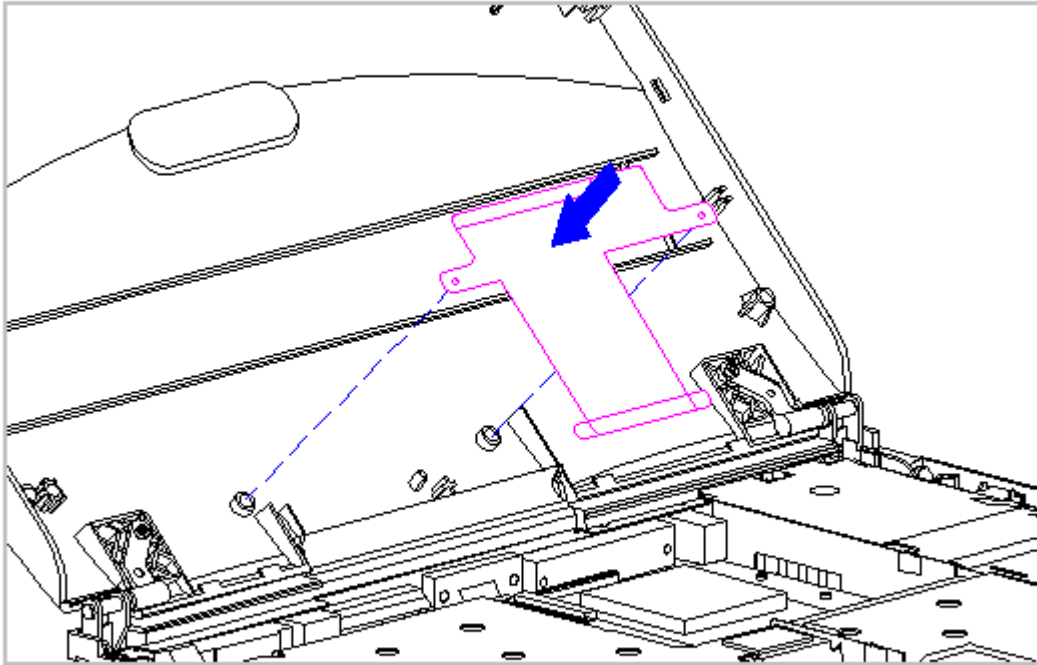

Figure 3-94. Replacing the Display Ground Cable (Models 400 and 410)

2. Replace the display cable on the monochrome LCD panel by carefully inserting the end of the display cable into the ZIF connector slide on the LCD panel (Figure 3-95).

IMPORTANT: Ensure that the ZIF connector slide is in its fully upward position and that it remains so while you are inserting the cable into it. Before closing the slide, ensure that the cable is fully seated in the ZIF connector.

3. While holding the end of the display cable inside the ZIF connector slide, press down both ends of the slide simultaneously to secure the cable in the ZIF connector (Figure 3-95).

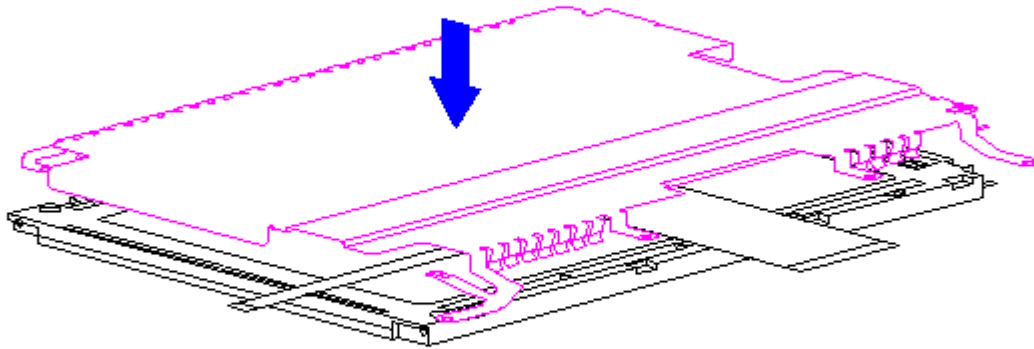

Figure 3-96. Placing the Shield on the Monochrome LCD Panel (Models 400 and 410)

5. Place the shield tabs in the indentations on the right side of the Monochrome LCD panel (Figure 3-97).

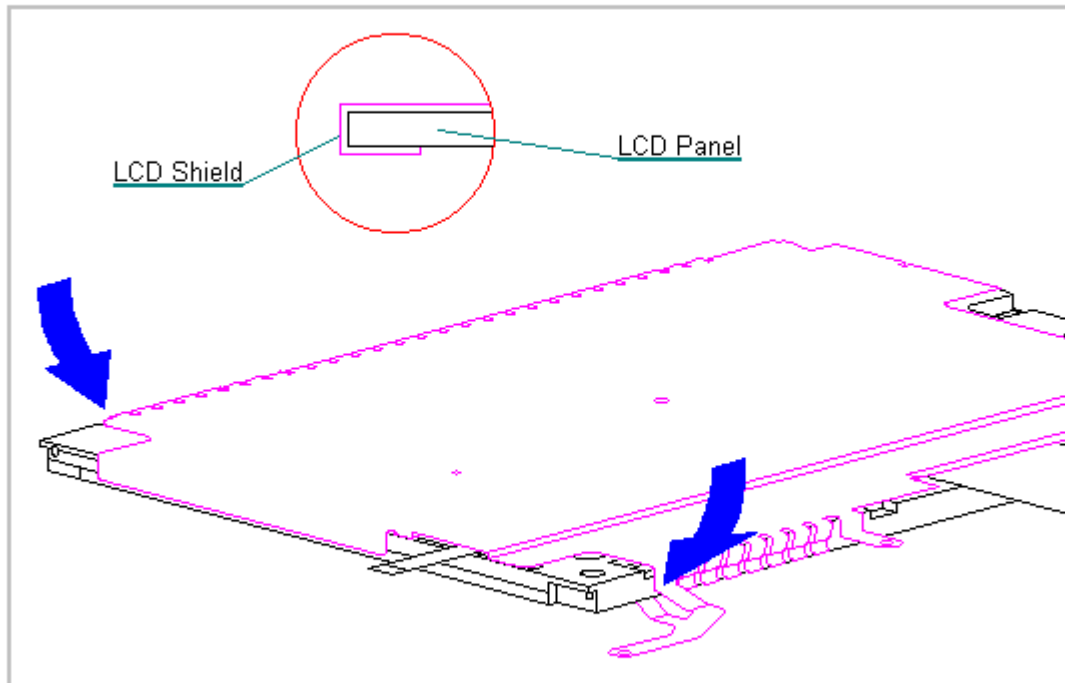

Figure 3-97. Positioning the Display Shield Tabs (Models 400 and 410)

6. Align the Monochrome LCD panel, shield, and cable in the display enclosure and replace the screws. Ensure that the ZIF connector end of the display cable and the end of the display ground cable are exposed at the bottom of the display enclosure (Figure 3-98).

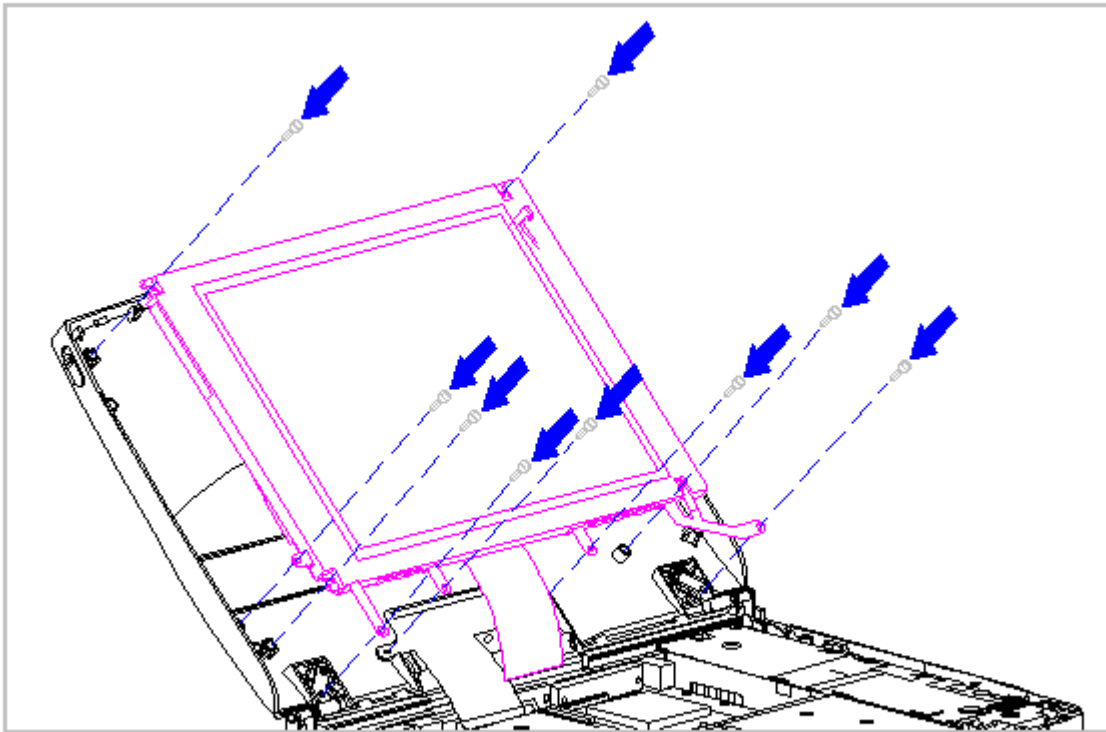

Figure 3-98. Aligning the Monochrome LCD Panel and the Display Shield (Models 400 and 410)

7. Connect the display cable and the backlight cable to the inverter board (Section 3.21).
8. Replace the inverter board (Section 3.21).
9. Replace the bezel (Section 3.21).
10. Connect the display ground cable [1] to the LIF clip above the serial port connector (Figure 3-99).
11. Carefully insert the end of the display ground cable into the ZIF connector slide on the system board (Figure 3-99).

IMPORTANT: Ensure that the ZIF connector slide is in its fully upward position and that it remains so while you are inserting the cable into it. Before closing the slide, ensure that the cable is fully seated (to the white insertion line) in the ZIF connector.

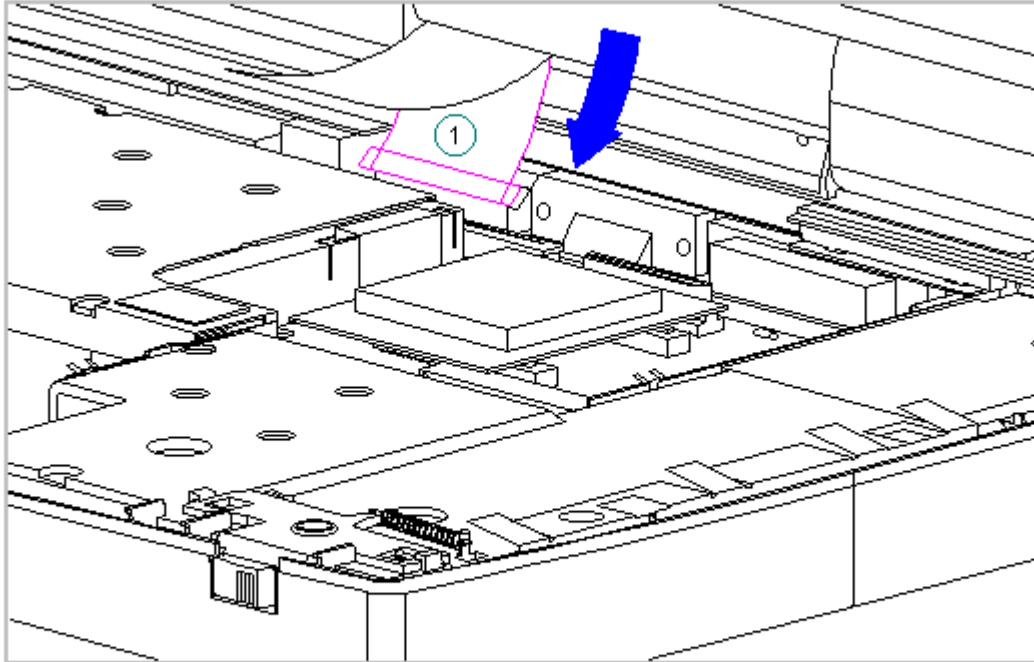

Figure 3-99. Connecting the Display Ground Cable (Models 400 and 410)

12. While holding the end of the display cable inside the ZIF connector slide, press down both ends of the slide simultaneously to secure the cable in the ZIF connector (Figure 3-100).

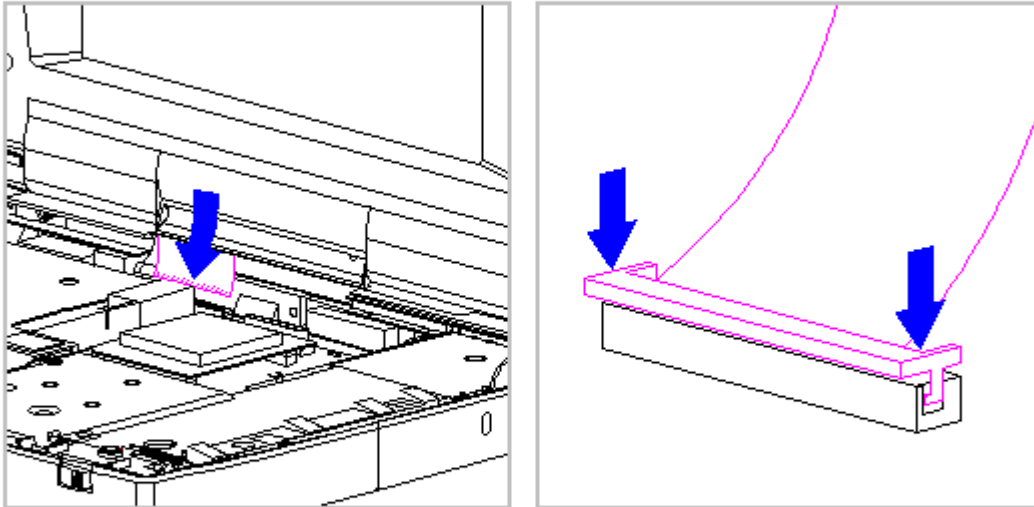

Figure 3-100. Connecting the Display Cable to the System Board (Models 400 and 410)

13. Ensure that the cable has been seated evenly and that the white line on the cable is level.
14. Replace the keyboard assembly (Section 3.7).

Chapter 3.23 Color STN (9.5 inch) Display (Models 400 and 410)

IMPORTANT: The Monochrome, CSTN and the CTFT displays have different removal and replacement procedures. Be sure to follow the procedures for the specific display.

This sections contains removal and replacement procedures for the following CSTN (9.5 inch) display components:

- o Display panel
- o Shield
- o Display cable
- o Display ground cable

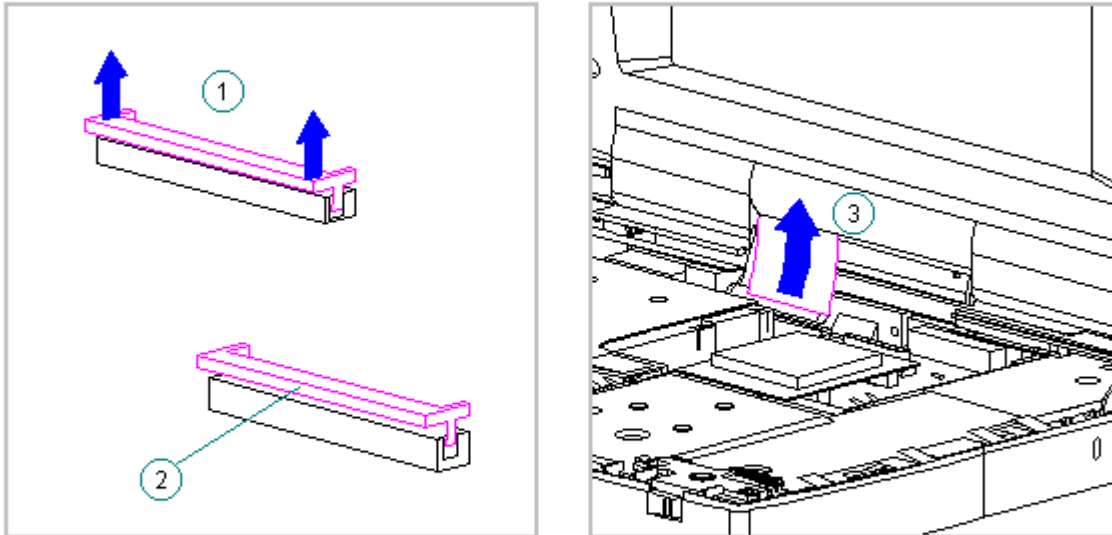

Figure 3-101. Removing the Display Cable from the System Board (Models 400 and 410)

6. Disconnect the display ground cable [1] from the LIF clip above the serial port connector (Figure 3-102).

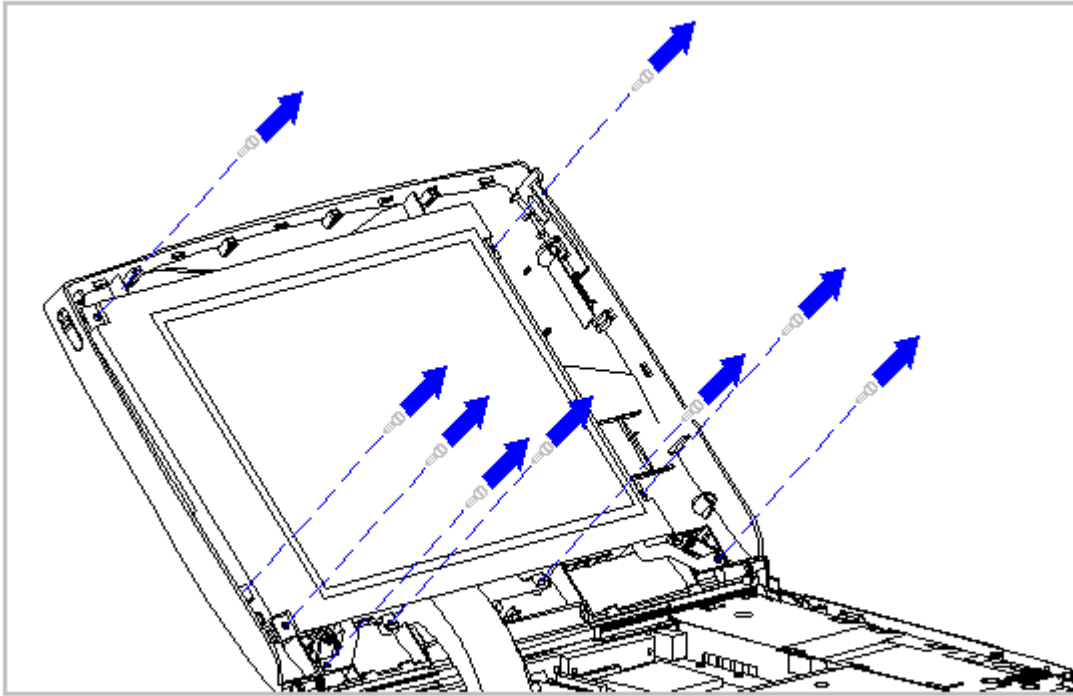

Figure 3-104. Removing the Screws from the CSTN (9.5 inch) Panel and Shield
(Models 400 and 410)

12. Carefully remove the CSTN (9.5 inch) panel, display cable, and shield from the display enclosure (Figure 3-105).

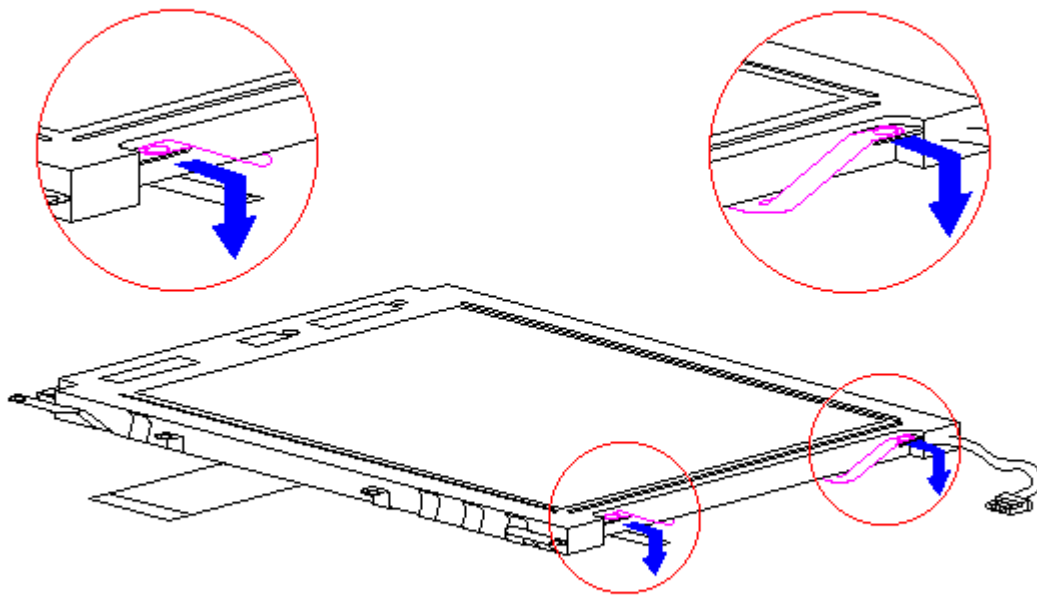

Figure 3-106. Removing the Display Shield Tabs (Models 400 and 410)

14. Lay the CSTN (9.5 inch) panel face down on a clean surface.
15. Slide the display shield off the CSTN (9.5 inch) panel (Figure 3-107).

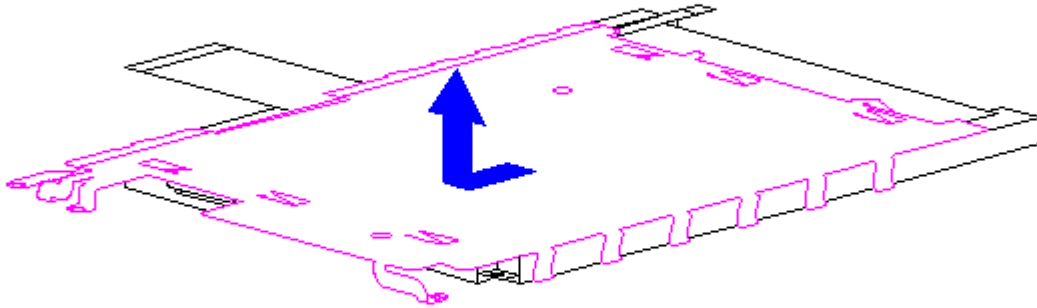

Figure 3-107. Removing the Display Shield from the CSTN (9.5 inch) Panel (Models 400 and 410)

16. Disconnect the display cable from the connector on the back of the CSTN (9.5 inch) panel (Figure 3-108).

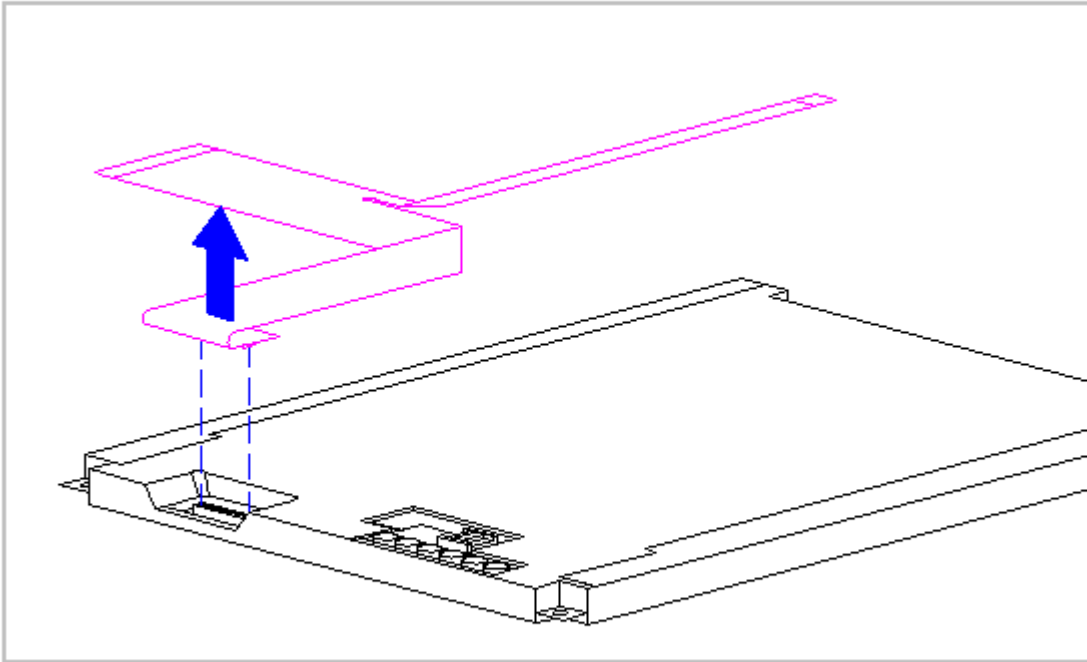

Figure 3-108. Removing the Display Cable from the CSTN (9.5 inch) Panel (Models 400 and 410)

17. Lift the display ground cable out of the display enclosure (Figure 3-109).

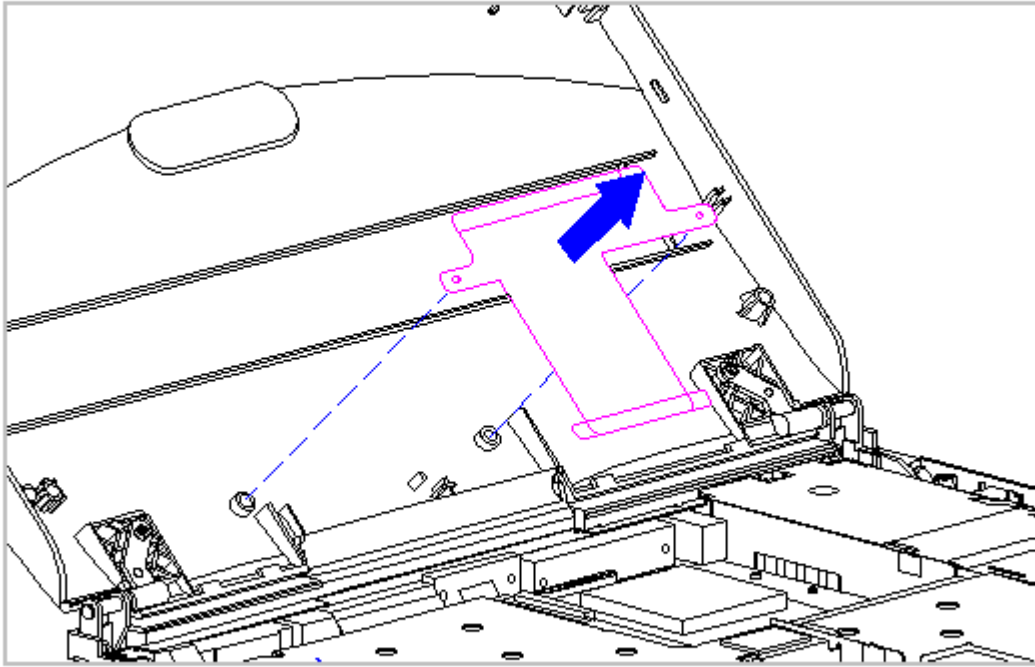

Figure 3-109. Removing the Display Ground Cable from the Display Enclosure
(Models 400 and 410)

Replacing the Display Ground Cable, Display Cable, Shield, and the CSTN
(9.5 inch) Panel

To replace the display ground cable, the display cable, the shield, and
the CSTN (9.5 inch) panel, follow these steps:

1. Position the display ground cable in the display enclosure, aligning
the cable with the bosses in the display enclosure (Figure 3-110).

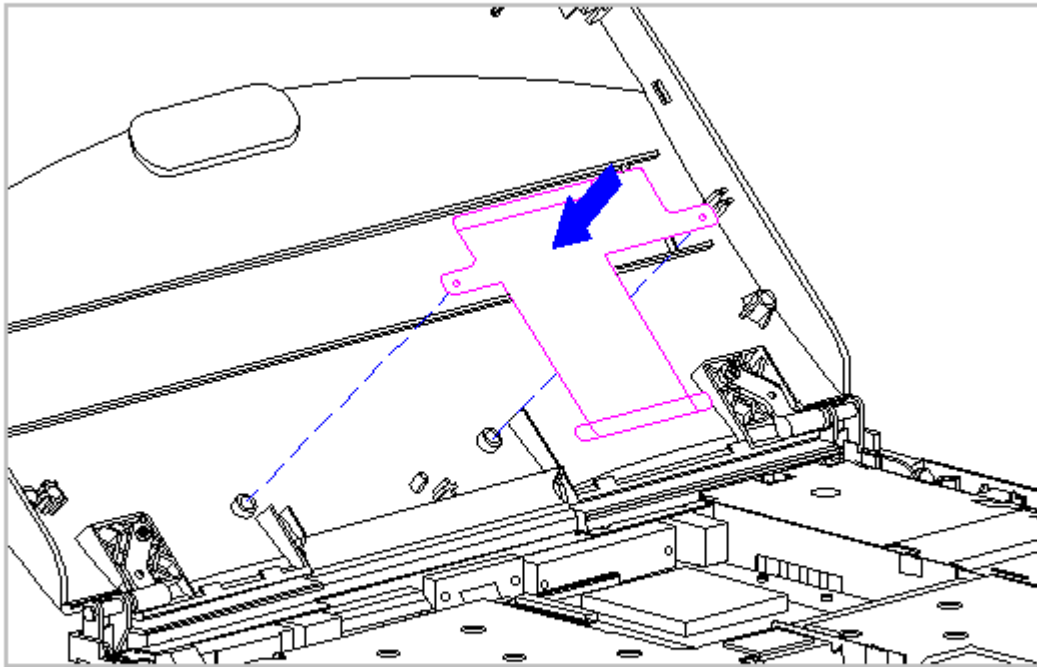

Figure 3-110. Replacing the Display Ground Cable (Models 400 and 410)

2. Connect the display cable to the connector on the back of the CSTN (9.5 inch) panel (Figure 3-111).

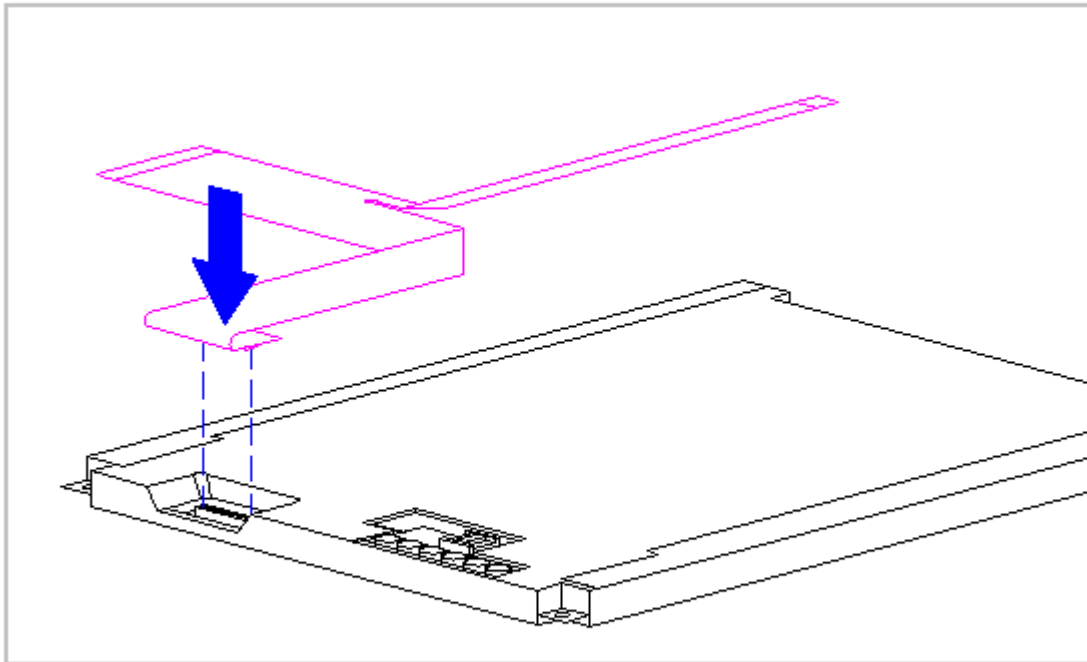

Figure 3-111. Replacing the Display Cable to the CSTN (9.5 inch) Panel (Models 400 and 410)

3. Slightly lift the tabs on the left side of the display shield and slide the shield onto the CSTN (9.5 inch) panel. Ensure that the LIF connector end of the display cable is exposed on the right side of the CSTN (9.5 inch) panel (Figure 3-112).

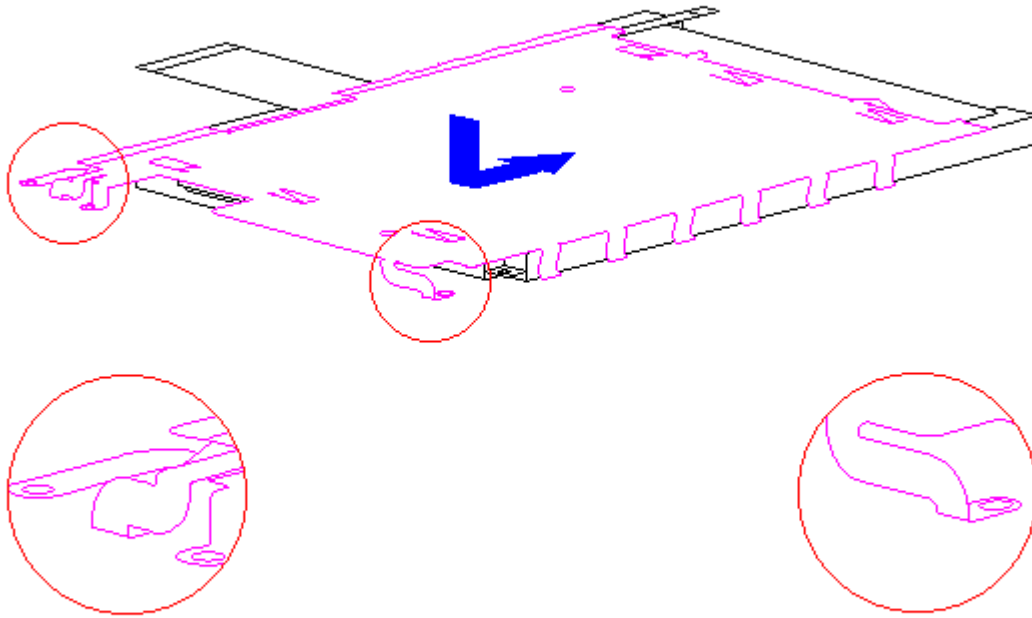

Figure 3-112. Placing the Display Shield on the CSTN (9.5 inch) Panel (Models 400 and 410)

4. Place the display shield tabs in the indentations on the sides of the CSTN (9.5 inch) panel (Figure 3-113).

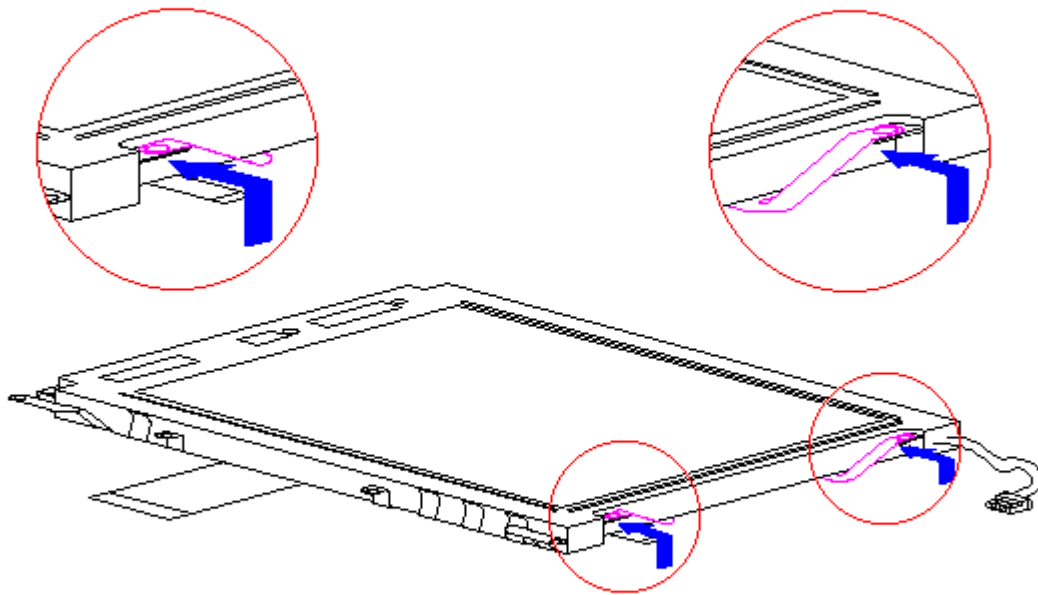

Figure 3-113. Positioning the Display Shield Tabs (Models 400 and 410)

5. Align the CSTN (9.5 inch) panel, display cable, and shield in the display enclosure and replace the screws. Ensure that the ZIF connector end of the display cable and the end of the display ground cable are exposed at the bottom of the display enclosure (Figure 3-114).

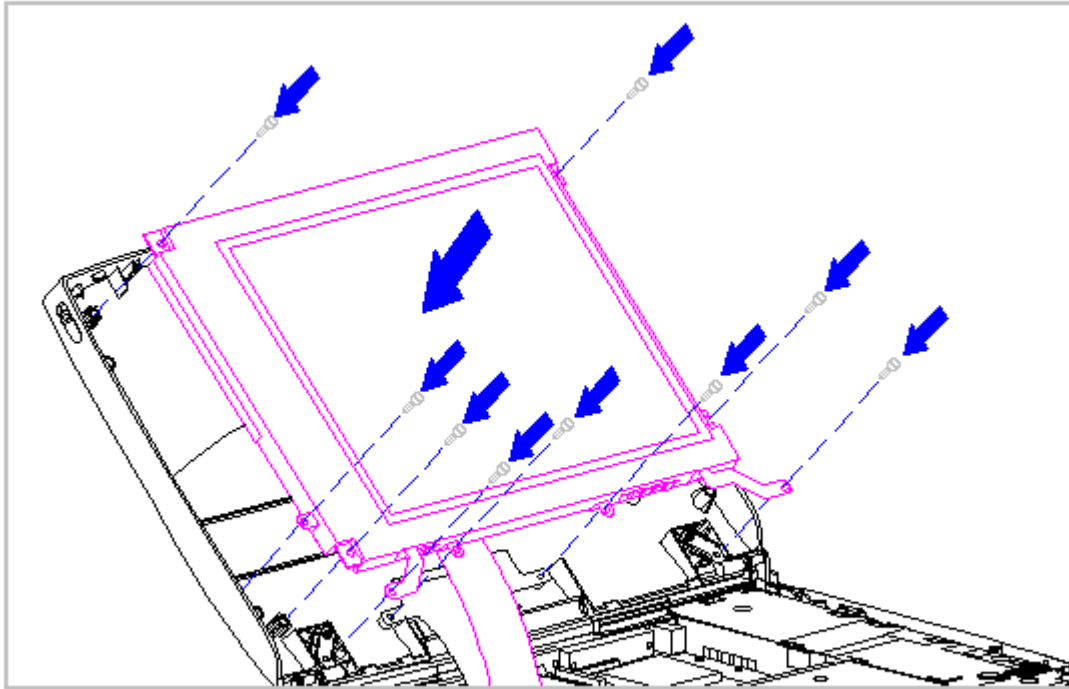

Figure 3-114. Aligning the CSTN (9.5 inch) Panel and the Display Shield (Models 400 and 410)

6. Connect the display cable and the backlight cable to the inverter board (Section 3.23).
7. Replace the inverter board (Section 3.23).
8. Replace the bezel (Section 3.23).
9. Connect the display ground cable [1] from the LIF clip above the serial port connector (Figure 3-115).

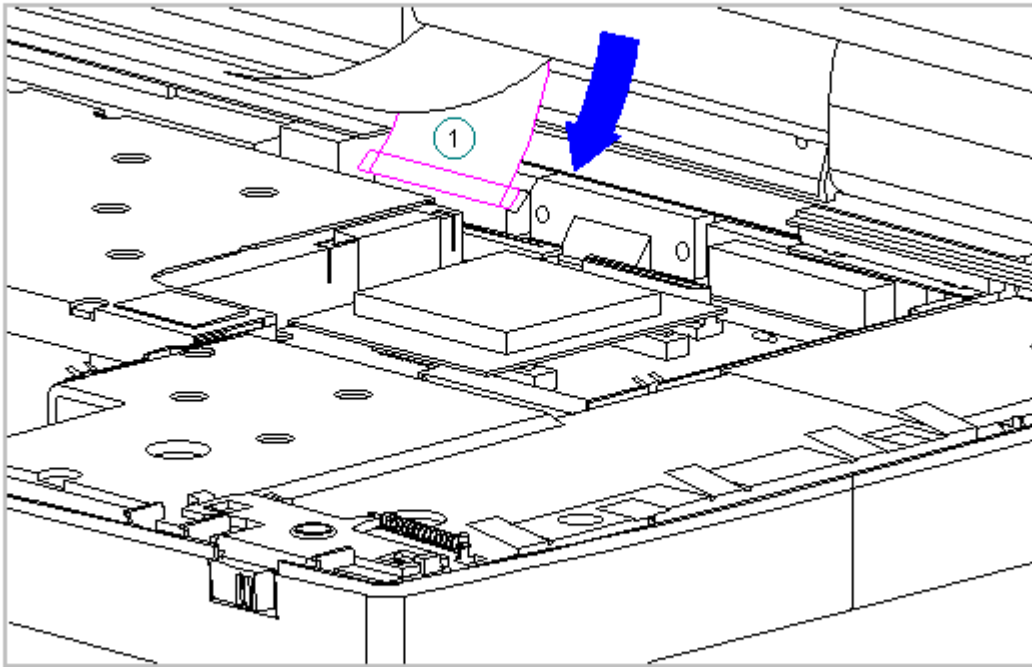

Figure 3-115. Connecting the Display Ground Cable (Models 400 and 410)

10. Carefully insert the end of the display cable into the ZIF connector slide on the system board.

IMPORTANT: Ensure that the ZIF connector slide is in its fully upward position and that it remains so while you are inserting the cable into it. Before closing the slide, ensure that the cable is fully seated (to the white insertion line) in the ZIF connector.

11. While holding the end of the display cable inside the ZIF connector slide, press down both ends of the slide simultaneously to secure the cable in the ZIF connector (Figure 3-116).

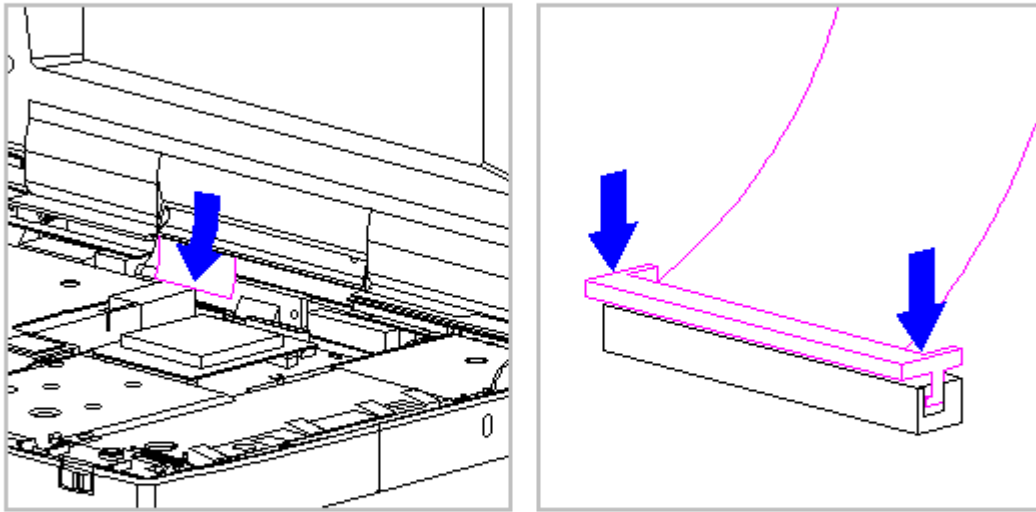

Figure 3-116. Connecting the Display Cable to the System Board

12. Ensure that the cable has been seated evenly and that the white line on the cable is level.
13. Replace the keyboard assembly (Section 3.7).

Chapter 3.24 Color TFT (8.4 inch) Display (Models 400 and 410)

IMPORTANT: The Monochrome, CSTN and the CTFT displays have different removal and replacement procedures. Be sure to follow the procedures for the specific display.

This sections contains removal and replacement procedures for the following color CTFT (8.4 inch) display components:

- o Display panel
- o Display cable
- o Shield
- o Display ground cable

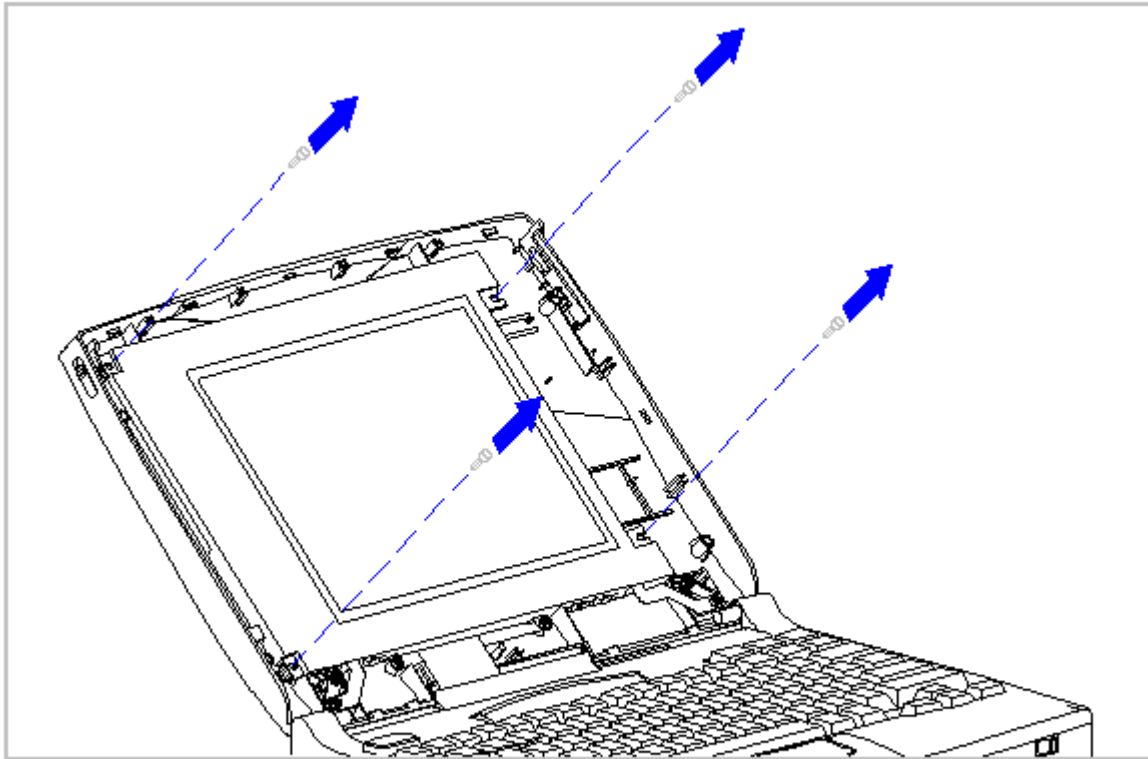

Figure 3-118. Removing the Screws from the CTFT (8.4 inch) Panel (Models 400 and 410)

8. Carefully rotate the CTFT (8.4 inch) panel down and out of the display enclosure, laying the CTFT (8.4 inch) panel gently on the keyboard assembly (Figure 3-119).

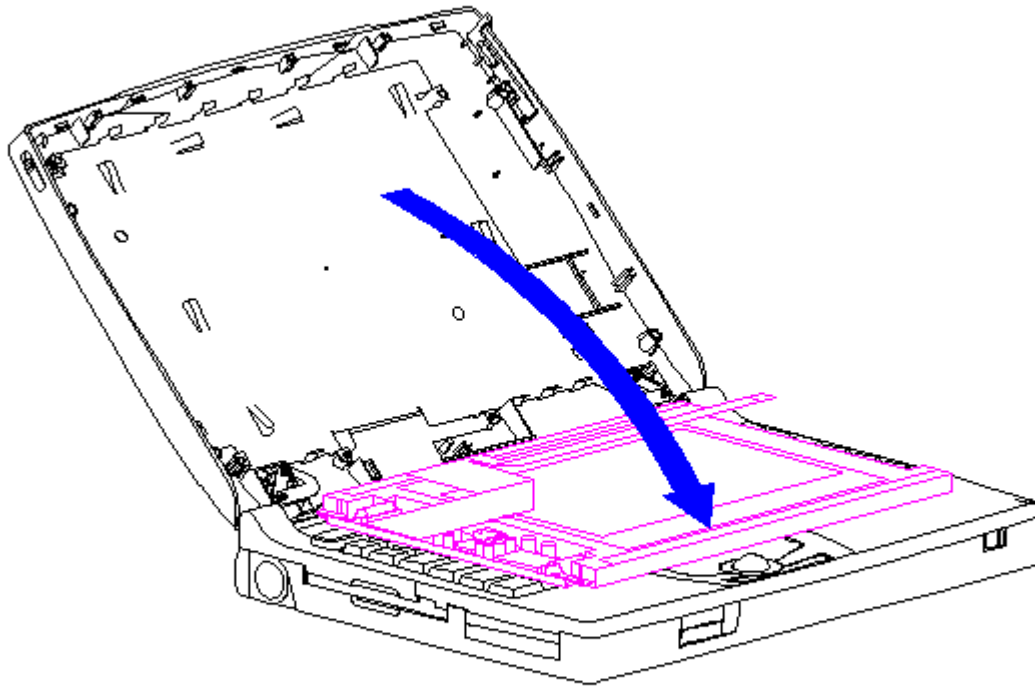

Figure 3-119. Removing the CTFT (8.4 inch) Panel from the Display Enclosure (Models 400 and 410)

9. Remove the display cable from the connector on the back of the panel by pulling the tabs at the back of the connector (Figure 3-120).

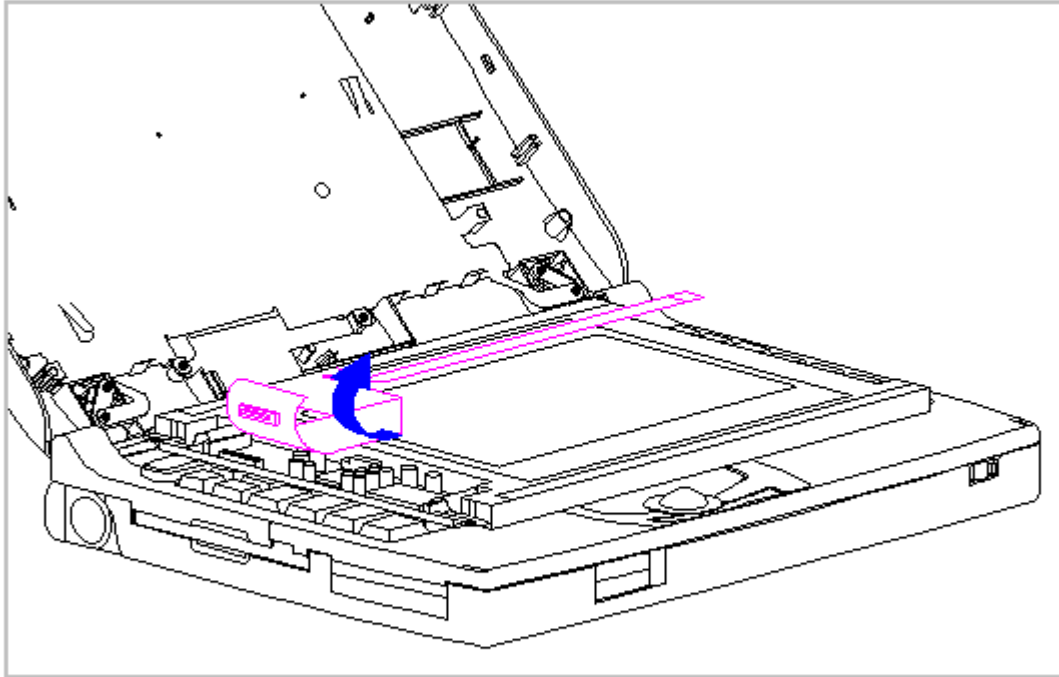

Figure 3-120. Removing the Display Cable from the CTFT (8.4 inch) Panel (Models 400 and 410)

Replacing the CTFT (8.4 inch) Display Panel

To replace the CTFT (8.4 inch) panel, follow these steps:

1. Connect the display cable to the connector on the back of the CTFT (8.4 inch) panel (Figure 3-121).

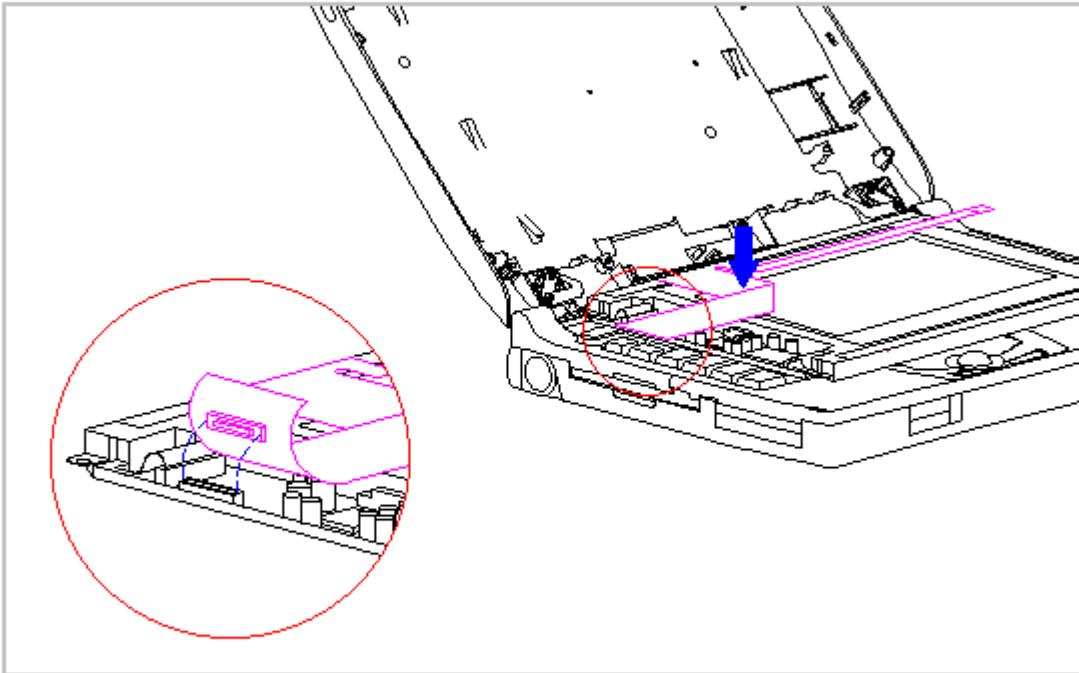

Figure 3-121. Connecting the Display Cable to the CTFT (8.4 inch) Panel (Models 400 and 410)

2. Position the CTFT (8.4 inch) panel into the display enclosure, ensuring that the ZIF connector end of the display cable is exposed on the right side of the CTFT (8.4 inch) panel (Figure 3-122).

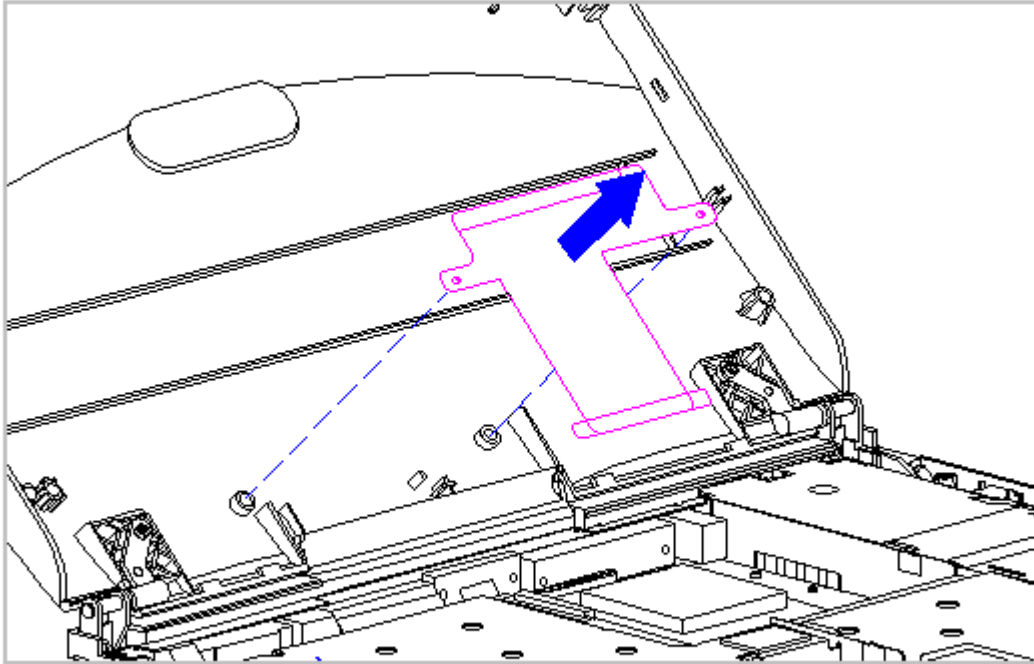

Figure 3-128. Removing the Display Ground Cable (Models 400 and 410)

11. To replace the display ground cable, reverse the previous steps.

Chapter 3.25 Display Components (Models 420 and 430)

This section contains removal and replacement procedures for the following display assembly components:

- o Bezel
- o Latches
- o Inverter board

Removing and Replacing the Display Bezel

To remove the display bezel, follow these steps:

1. Disconnect all power from the computer and remove the AC Adapter and battery pack (Section 3.2).

2. Open the computer.
3. Remove the four screws from the display bezel (Figure 3-129).

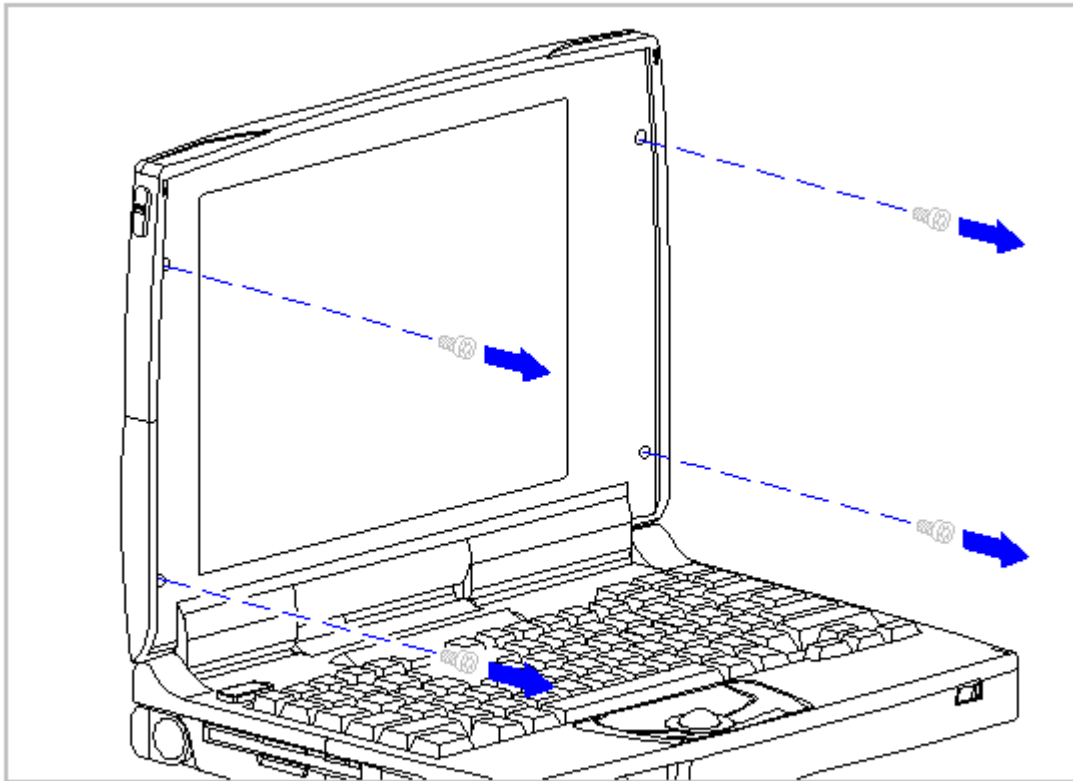

Figure 3-129. Removing the Display Bezel Screws (Models 420 and 430)

4. Separate the display bezel from the display assembly (Figure 3-130).

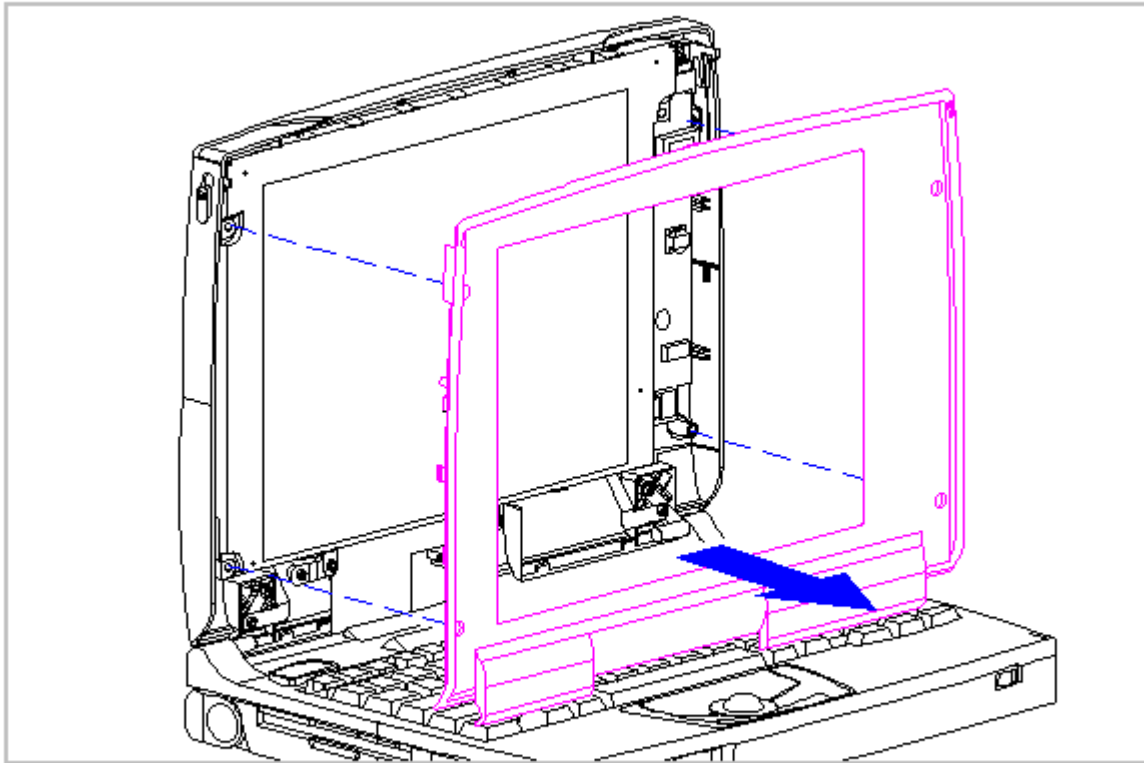

Figure 3-130. Removing the Display Bezel (Models 420 and 430)

5. To replace the bezel, reverse the previous steps.

Removing the Display Enclosure Latches and Springs

To remove the display enclosure latches and springs from either side of the display enclosure, follow these steps:

1. Disconnect all power from the computer and remove the AC Adapter and battery pack (Section 3.2).
2. Open the computer.
3. Remove the display bezel. Refer to "Removing and Replacing the Display Bezel" in this section.
4. Hold the bottom of the latch near the spring. Flex the hook end of the display latch away from the display enclosure [1] (Figure 3-131).
5. Pull the display latch from the top, then out of the display enclosure [2] (Figure 3-131).

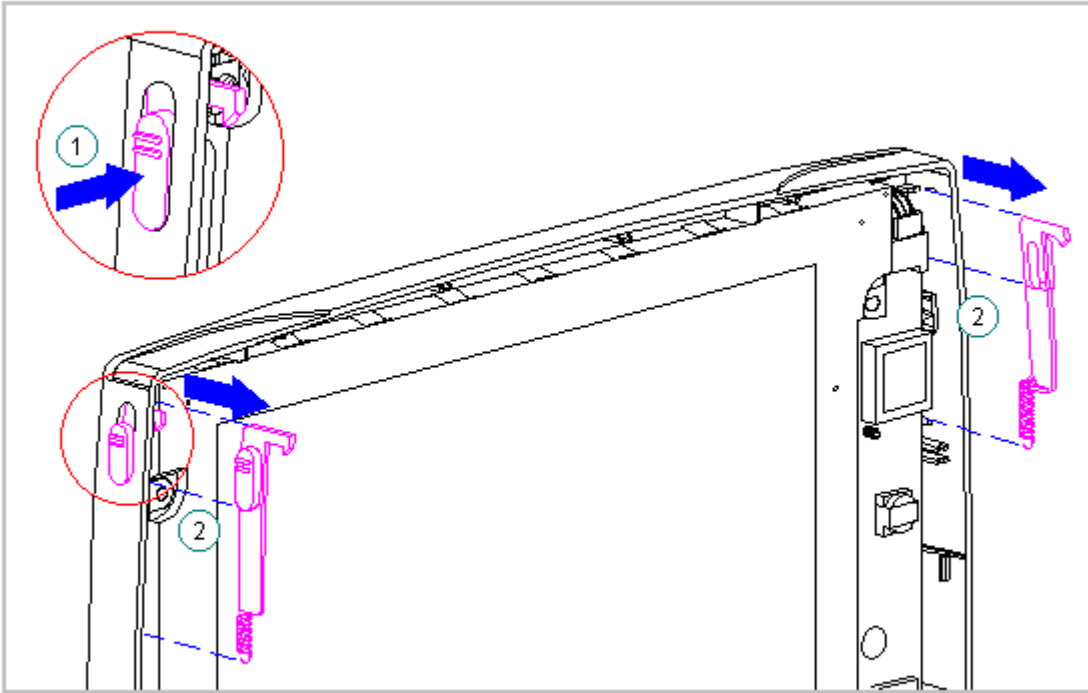

Figure 3-131. Removing the Display Latch from the Display Enclosure (Models 420 and 430)

6. Remove the display latch spring from the latch (Figure 3-132).

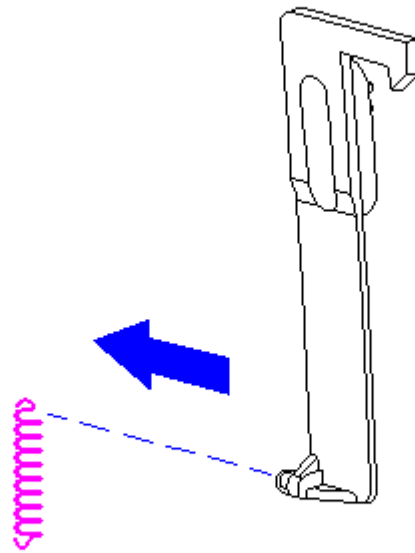

Figure 3-132. Removing the Display Latch Spring from the Latch (Models 420 and 430)

Replacing the Display Enclosure Springs and Latches

To replace the display springs and latches, follow these steps:

1. Hook the display latch spring on to the display latch [1] and place the display latch spring over the post in the display enclosure [2] (Figure 3-133).

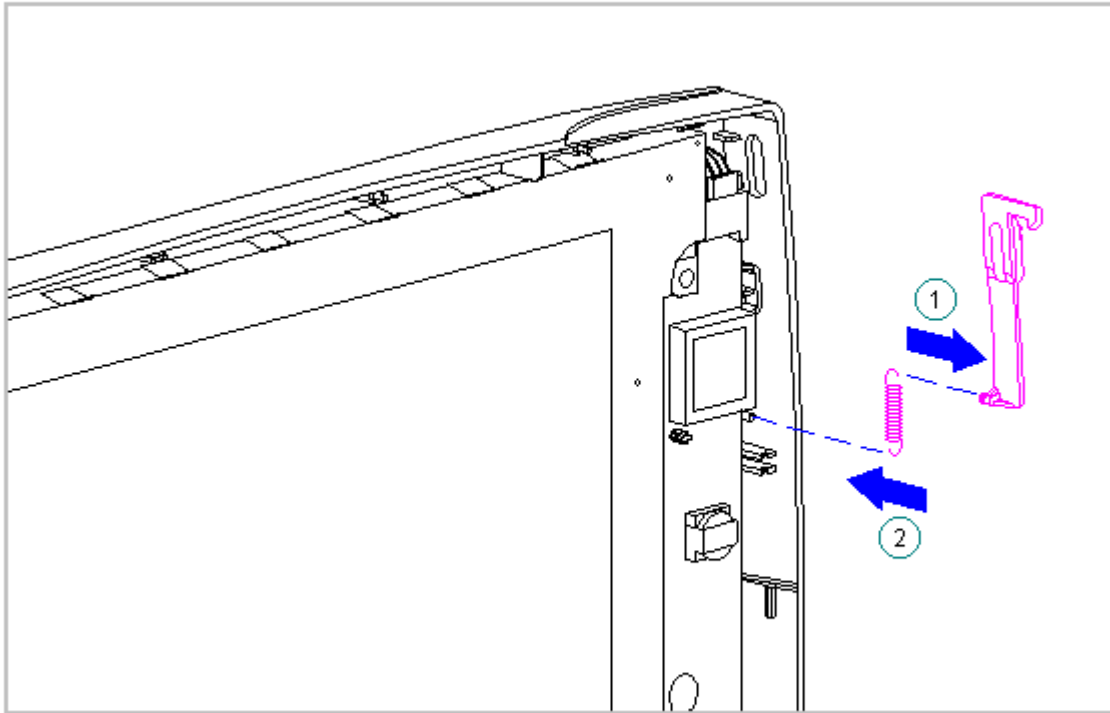

Figure 3-133. Replacing the Display Latch Spring (Models 420 and 430)

2. Slide the display latch into place on either side of the display enclosure (Figure 3-134).

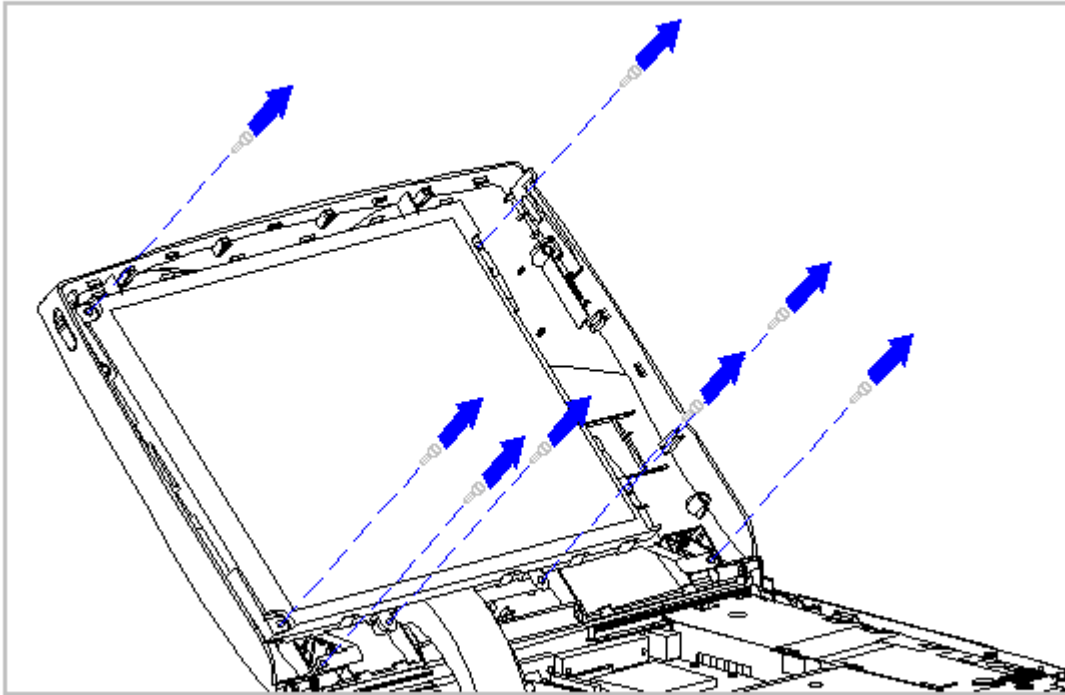

Figure 3-143. Removing the Screws from the CSTN (10.4 inch) Panel and Shield (Models 420 and 430)

12. Carefully remove the CSTN (10.4 inch) panel, display cable, and shield from the display enclosure (Figure 3-144).

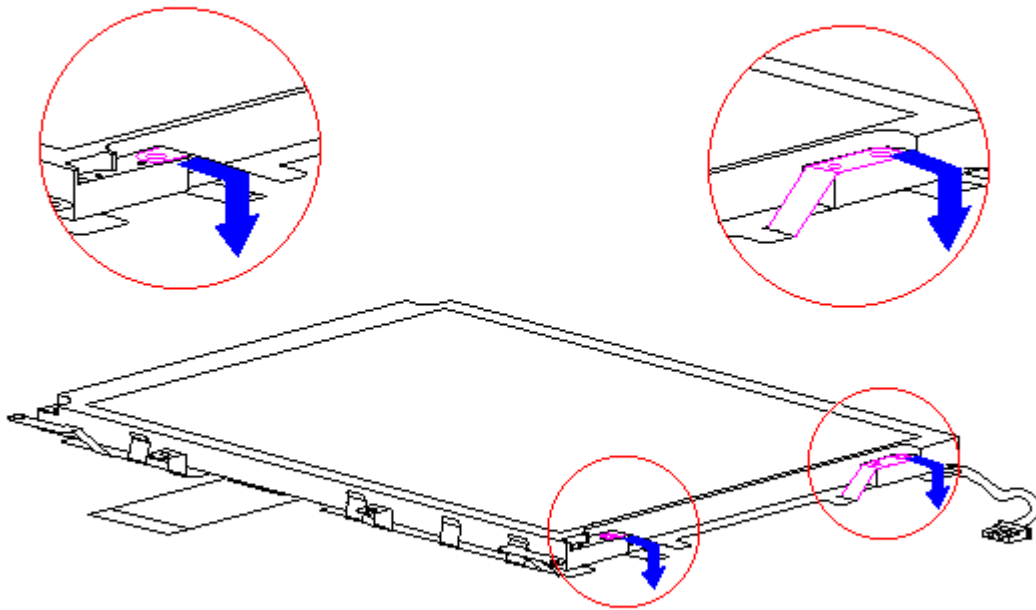

Figure 3-145. Removing the Display Shield Tabs (Models 420 and 430)

14. Lay the CSTN (10.4 inch) panel face down on a clean surface.
15. Slide the display shield off the CSTN panel (Figure 3-146).

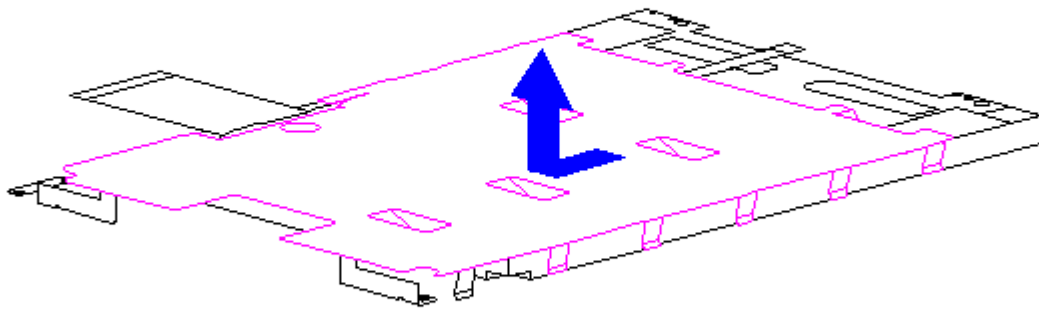

Figure 3-146. Removing the Display Shield from the CSTN (10.4 inch) Panel (Models 420 and 430)

16. Only Sharp panels require the XOVER Board. Remove the ground wire connecting the XOVER Board with the CSTN (10.4 inch) Panel (Figure 3-147).

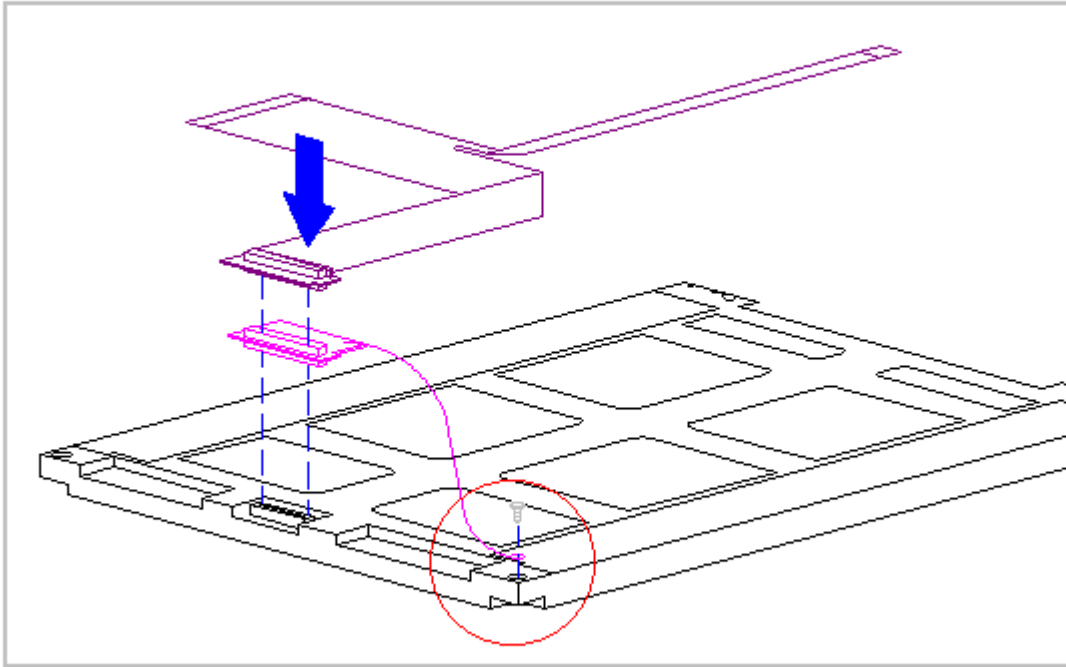

Figure 3-147 Removing the XOVER Board Ground Wire from the CSTN (10.4 inch) Panel (Models 420 and 430)

17. Disconnect the display cable from the connector on the back of the CSTN (10.4 inch) panel (Figure 3-148).

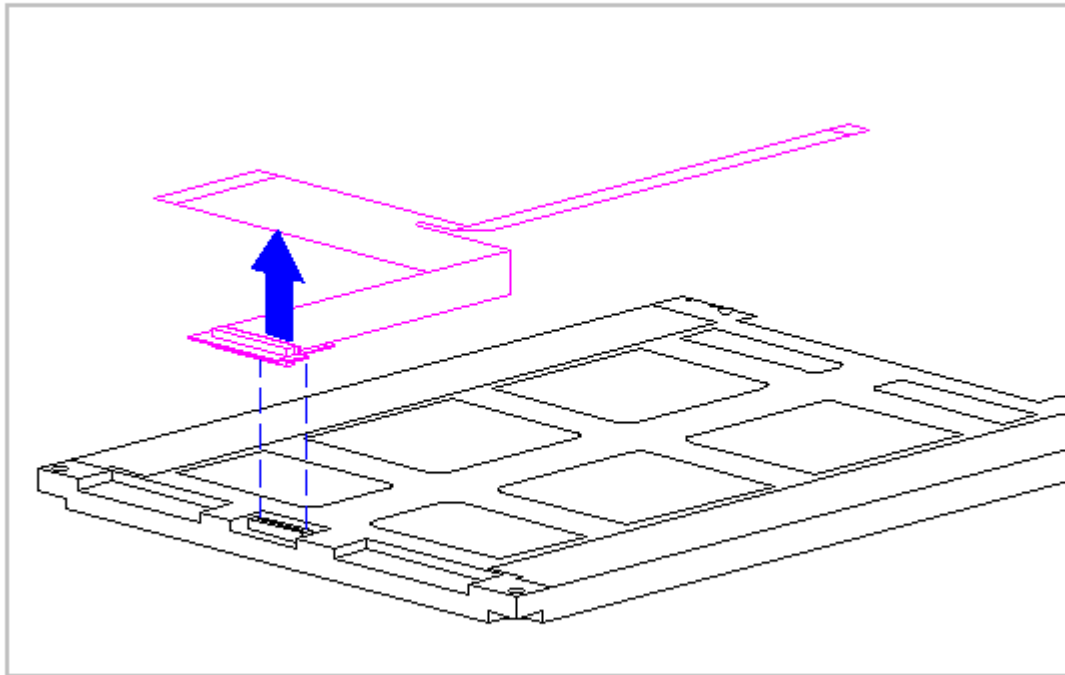

Figure 3-148. Removing the Display Cable from the CSTN (10.4 inch) Panel (Models 420 and 430)

17. Lift the display ground cable out of the display enclosure (Figure 3-149).

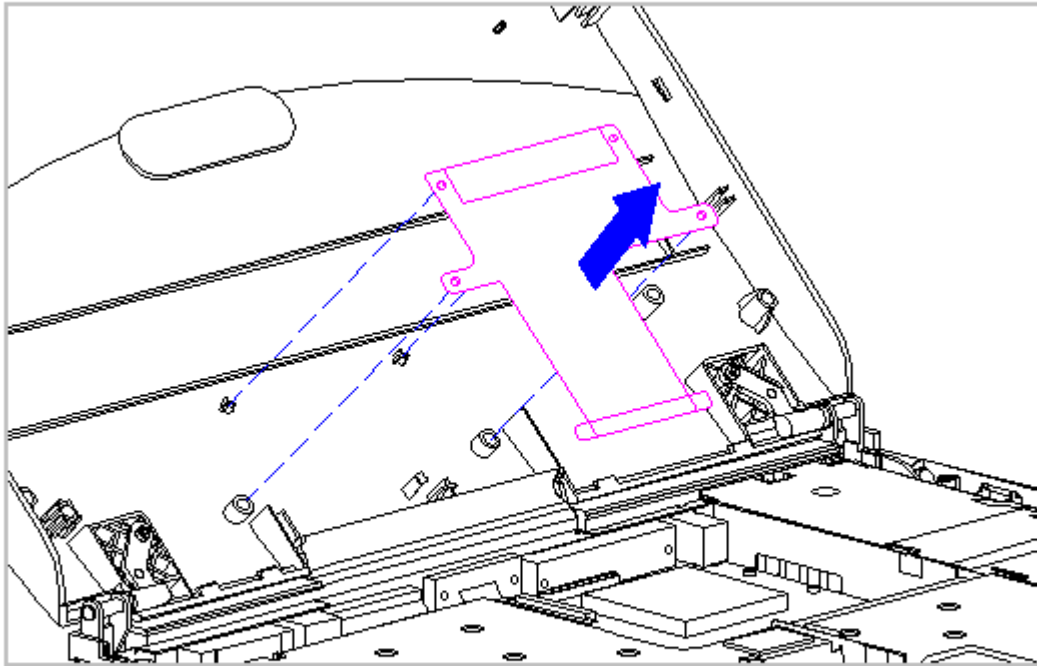

Figure 3-149. Removing the Display Ground Cable from the Display Enclosure (Models 420 and 430)

Replacing the Display Ground Cable, Display Cable, Shield, and the CSTN (10.4 inch) Panel

To replace the display ground cable, display cable, shield, and the CSTN (10.4 inch) panel, follow these steps:

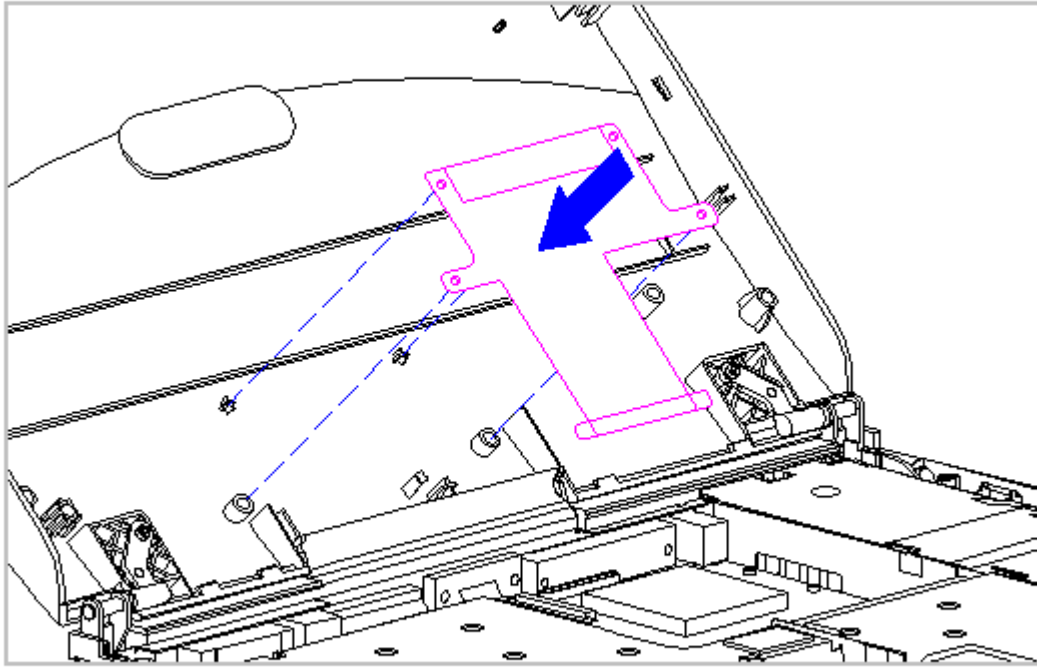

Figure 3-150. Replacing the Display Ground Cable (Models 420 and 430)

1. Position the display ground cable in the display enclosure, aligning the cable with the bosses in the display enclosure (Figure 3-151).
2. If the CSTN panel is manufactured by Sharp complete this step. If not, continue to step 4. Connect the display cable to the XOVER Board. Then connect the XOVER Board to the connector on the back of the CSTN (10.4 in) panel. Attach the ground wire of the XOVER Board to the display panel as indicated in (Figure 3-151).

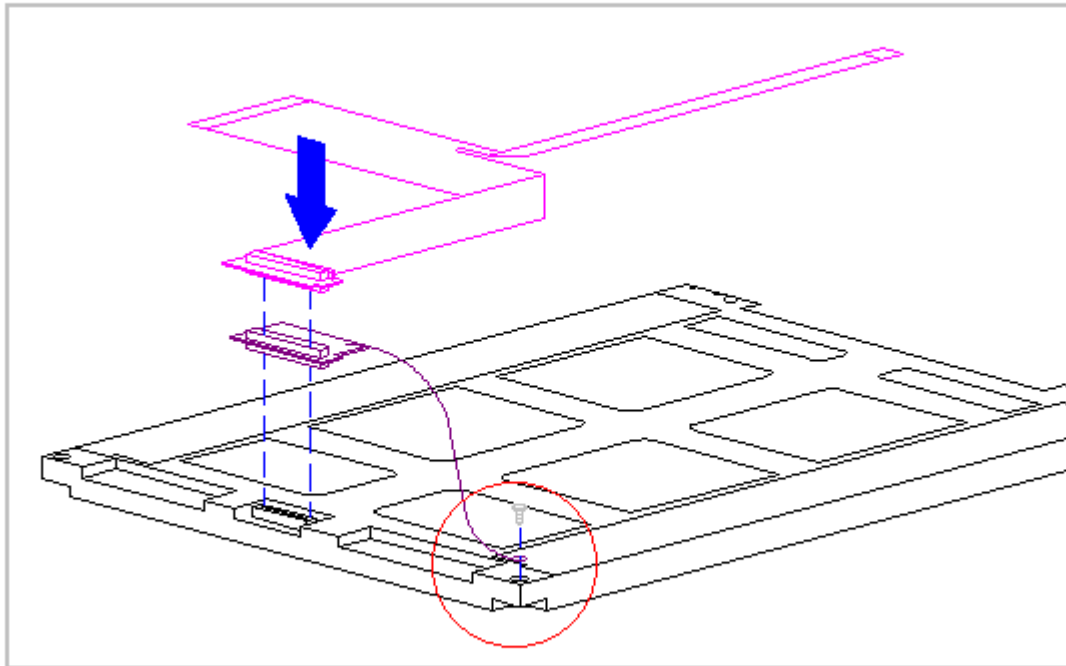

Figure 3-151. Replacing the Display Cable to the CSTN (10.4 inch) Panel (Models 420 and 430)

3. If the CSTN panel is manufactured by Sharp complete this step. If not, continue to the next step. Peel off the adhesive from the back of the rubber pad found in the spare kit. Place this pad on the display enclosure indicated by the embossed area (Figure 3-152).

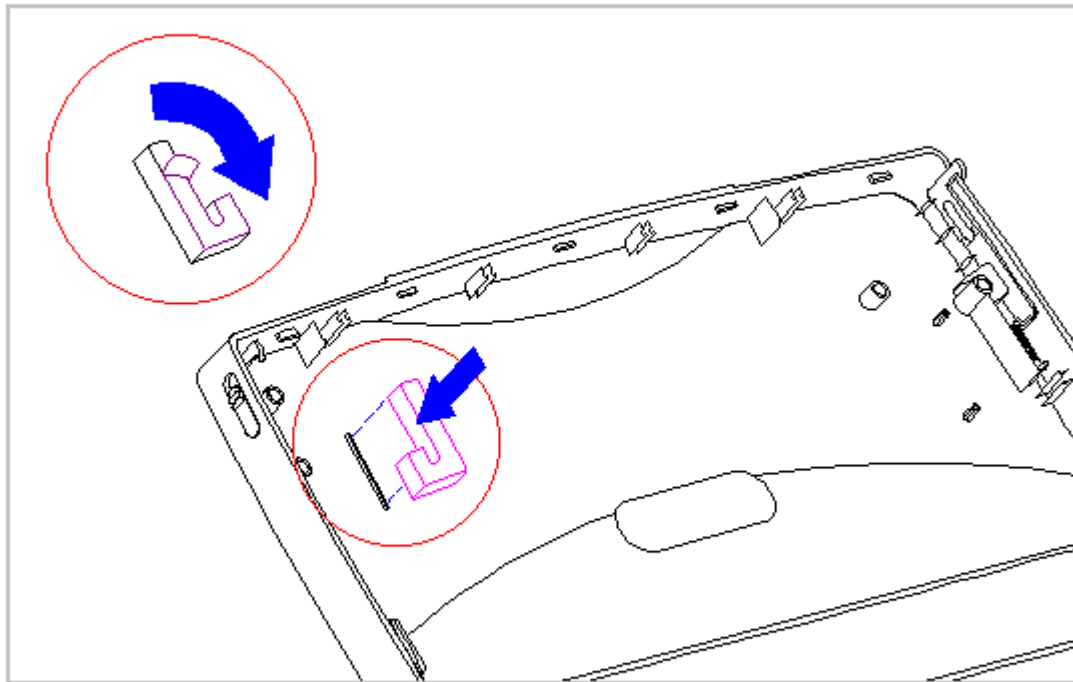

Figure 3-152. Adding the Rubber Pad for the Sharp CSTN (10.4 inch) Panel (Models 420 and 430)

4. Slightly lift the tabs on the left side of the display shield and slide the shield onto the CSTN (10.4 inch) panel. Ensure that the LIF connector end of the display cable is exposed on the right side of the CSTN (10.4 inch) panel (Figure 3-153).

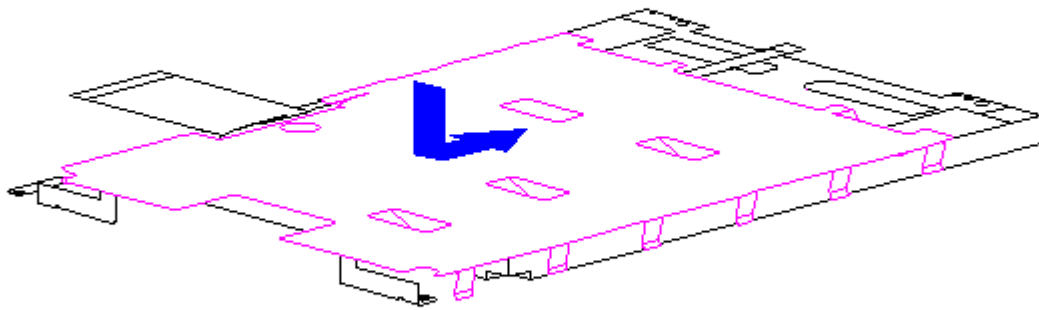

Figure 3-153. Placing the Display Shield on the CSTN (10.4 inch) Panel (Models 420 and 430)

5. Place the display shield tabs in the indentations on the sides of the CSTN (10.4 in) panel (Figure 3-154).

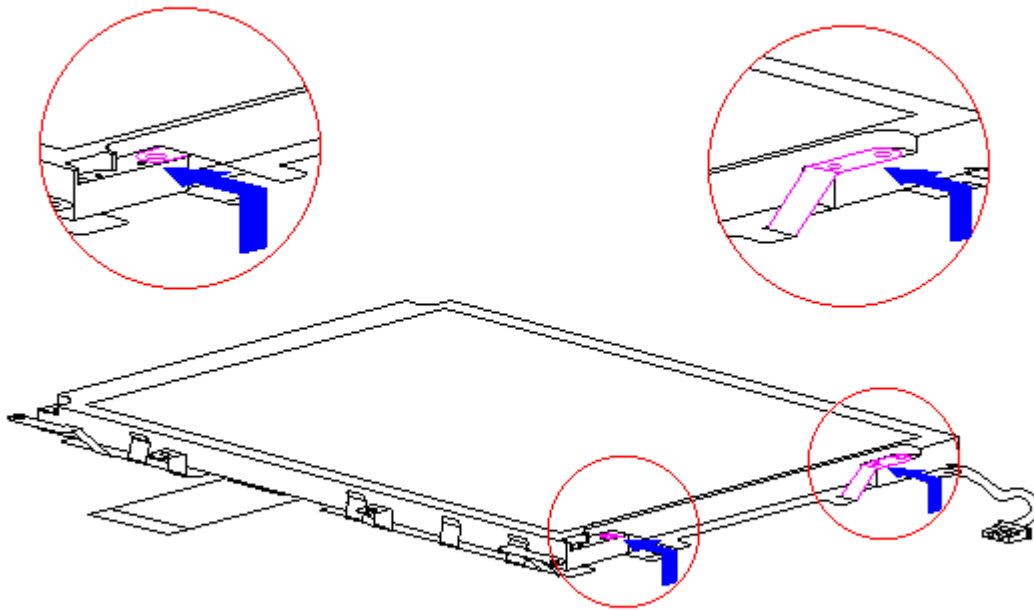

Figure 3-154. Positioning the Display Shield Tabs (Models 420 and 430)

6. Align the CSTN (10.4 inch) panel, display cable, and shield in the display enclosure and replace the screws. Ensure that the ZIF connector end of the display cable and the end of the display ground cable are exposed at the bottom of the display enclosure (Figure 3-155).

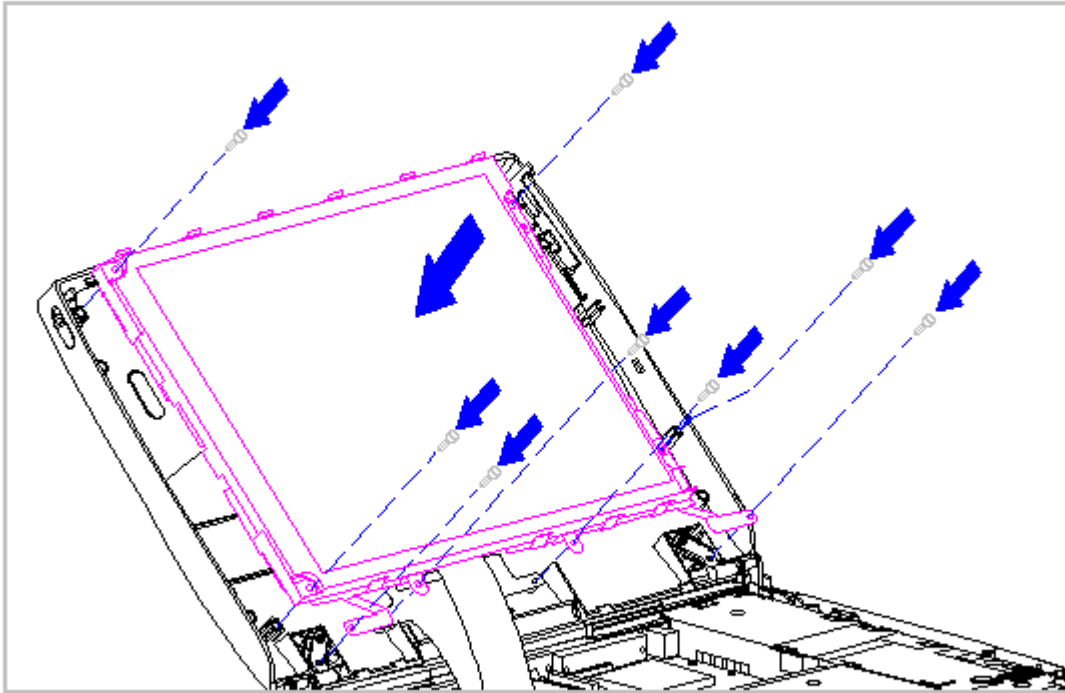

Figure 3-155. Replacing the CSTN (10.4 inch) Panel and the Display Shield (Models 420 and 430)

7. Connect the display cable and the backlight cable to the inverter board (Section 3.25).
8. Replace the inverter board (Section 3.25).
9. Replace the bezel (Section 3.25).
10. Connect the display ground cable [1] from the LIF clip above the serial port connector (Figure 3-156).

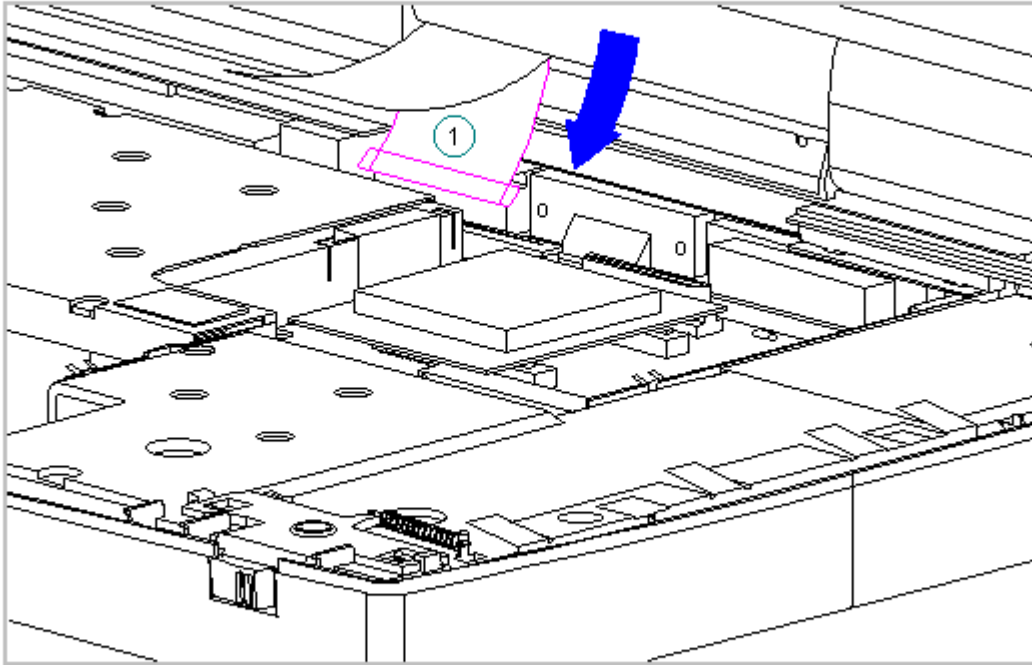

Figure 3-156. Connecting the Display Ground Cable (Models 420 and 430)

11. Carefully insert the end of the display ground cable into the ZIF connector slide on the system board.

IMPORTANT: Ensure that the ZIF connector slide is in its fully upward position and that it remains so while you are inserting the cable into it. Before closing the slide, ensure that the cable is fully seated (to the white insertion line) in the ZIF connector.

12. While holding the end of the display cable inside the ZIF connector slide, press down both ends of the slide simultaneously to secure the cable in the ZIF connector (Figure 3-157).

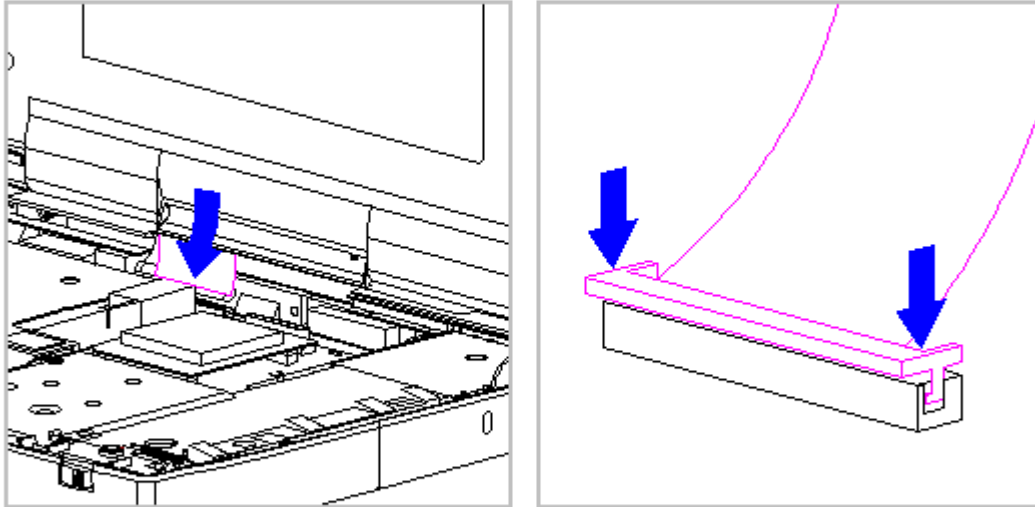

Figure 3-157. Connecting the Display Cable to the System Board (Models 420 and 430)

13. Ensure that the cable has been seated evenly and that the white line on the cable is level.
14. Replace the keyboard assembly (Section 3.7).

Chapter 3.27 Color TFT (10.4 inch) Display (Models 420 and 430)

IMPORTANT: The Monochrome, CSTN and the CTFT displays have different removal and replacement procedures. Be sure to follow the procedures for the specific display.

This sections contains removal and replacement procedures for the following CTFT (10.4 inch) display components:

- o Display panel
- o Display cable
- o Shield
- o Display ground cable

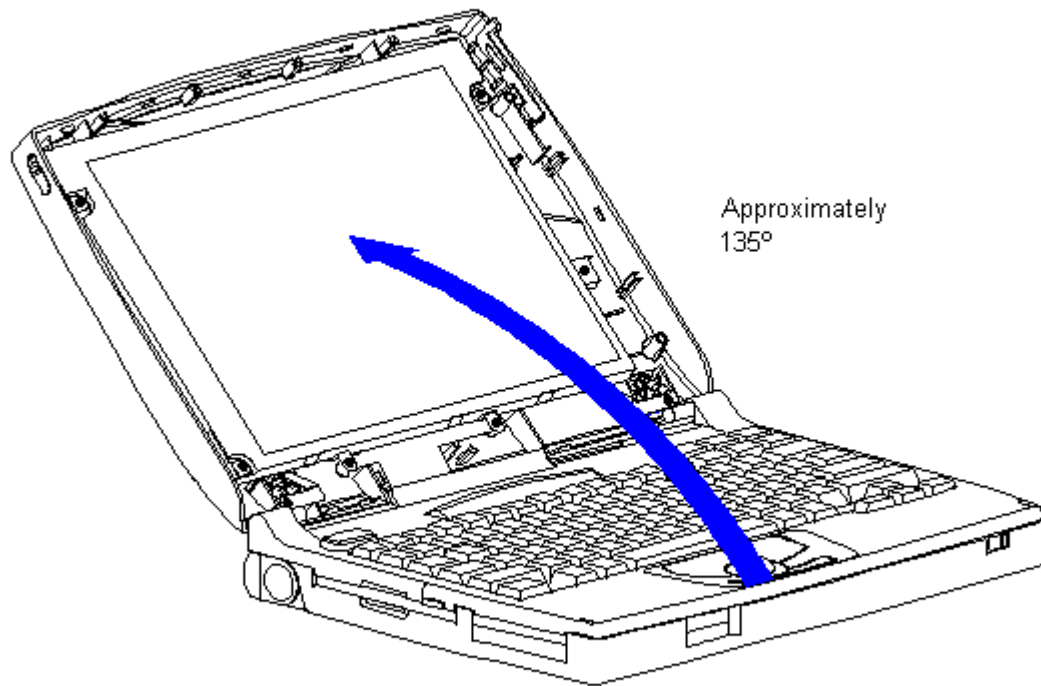

Figure 3-158. Opening the Display to Approximately 135-Degree Angle

NOTE: The CTFT (10.4 inch) display is different than all other displays. The inverter board fits partially behind the display. Loosen the screws on the display to slide the inverter out from behind the display.

5. Remove the inverter board (Section 3.25).
6. Remove the display cable and backlight cable from the inverter board (Section 3.25).
7. Remove the four screws that secure the CTFT (10.4 inch) panel to the display enclosure (Figure 3-159).

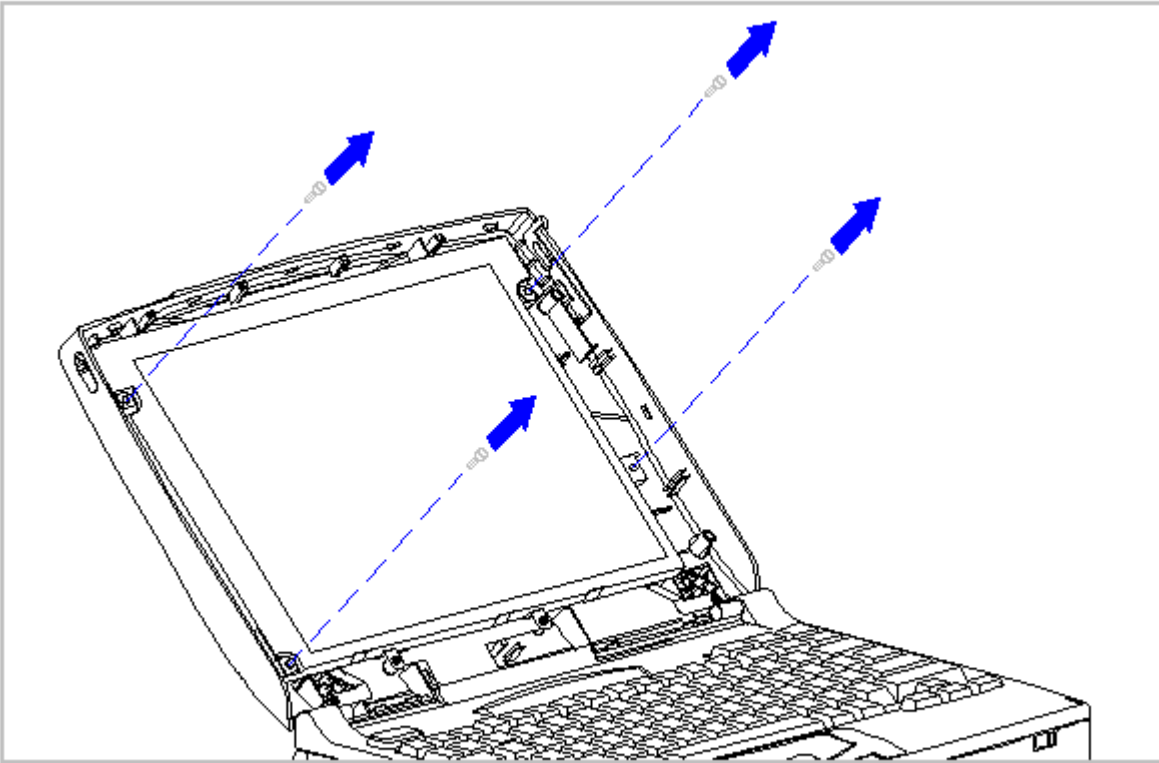

Figure 3-159. Removing the Screws from the CTFT (10.4 inch) Panel (Models 420 and 430)

8. Carefully rotate the CTFT (10.4 inch) panel down and out of the display enclosure, laying the CTFT (10.4 inch) panel gently on the keyboard assembly (Figure 3-160).

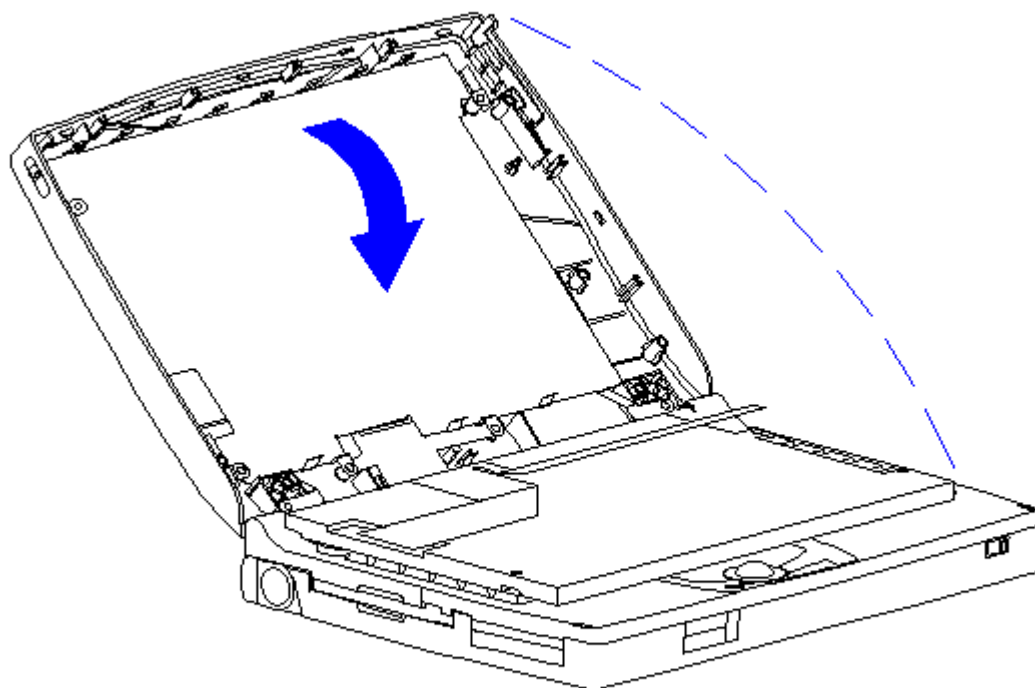

Figure 3-160. Removing the CTFT (10.4 inch) Panel from the Display Enclosure (Models 420 and 430)

9. Remove the display cable from the connector on the back of the panel (Figure 3-161).

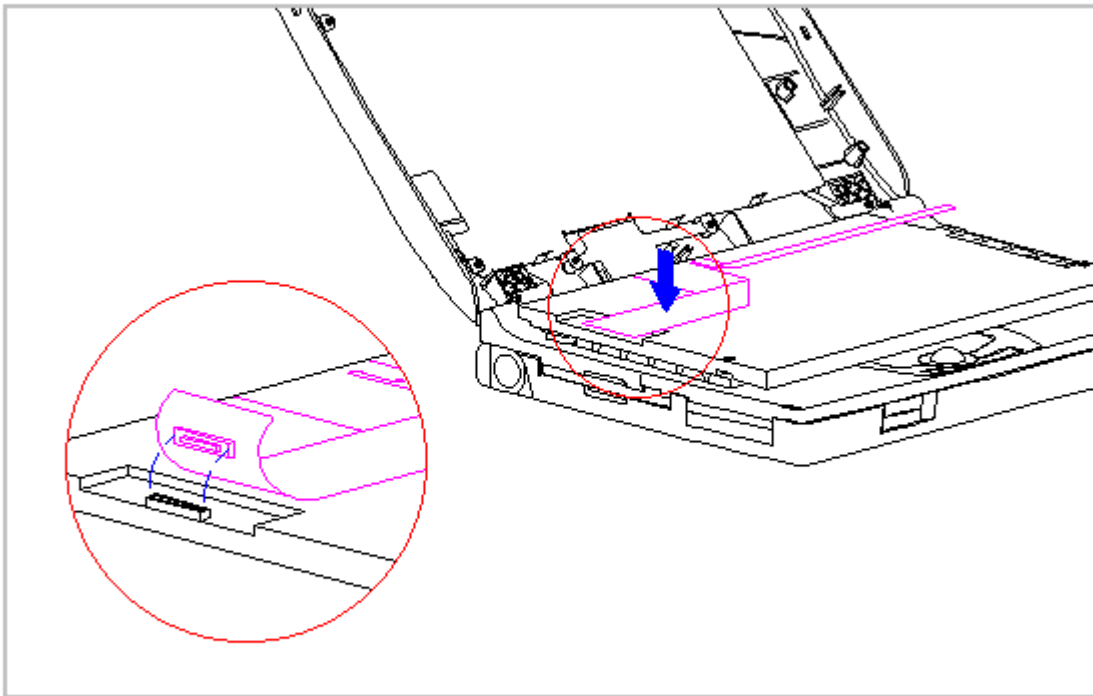

Figure 3-162. Connecting the Display Cable to the CTFT (10.4 inch) Panel (Models 420 and 430)

2. Position the CTFT (10.4 inch) panel into the display enclosure, ensuring that the ZIF connector end of the display cable is exposed on the right side of the CTFT (10.4 inch) panel (Figure 3-163).

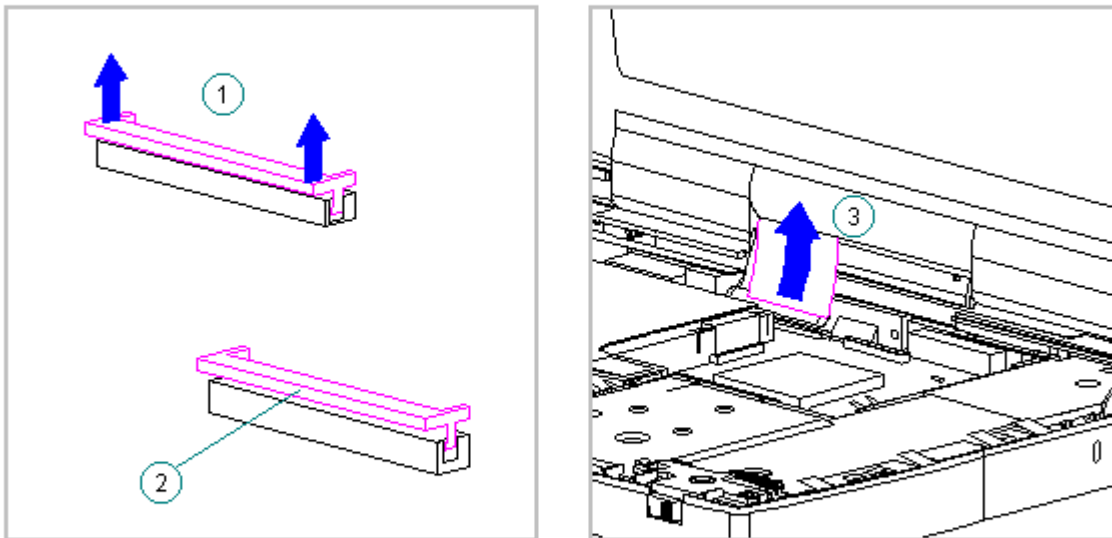

Figure 3-171. Disconnecting the Display Cable from the System Board (All Models)

8. Disconnect the display ground cable [1] from the LIF clip (Figure 3-172).

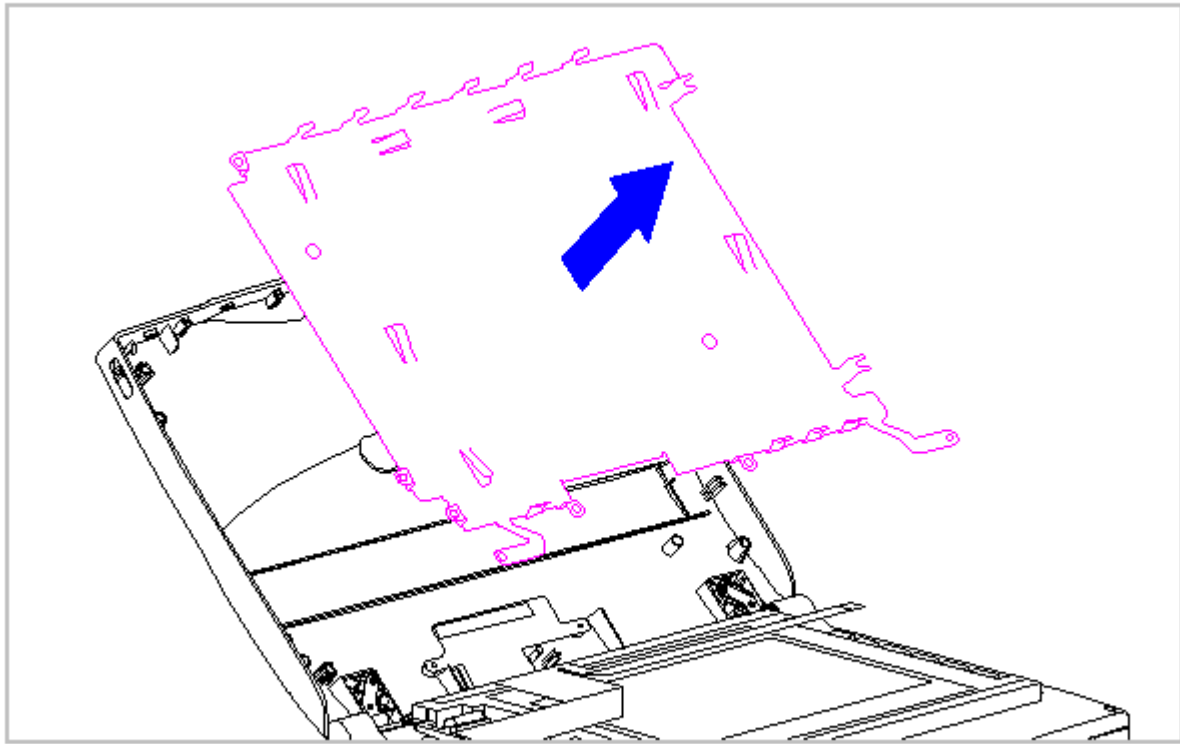

Figure 3-173. Removing the Rear Clutch Screws (All Models)

11. Lift the display assembly off the system unit module (Figure 3-174).

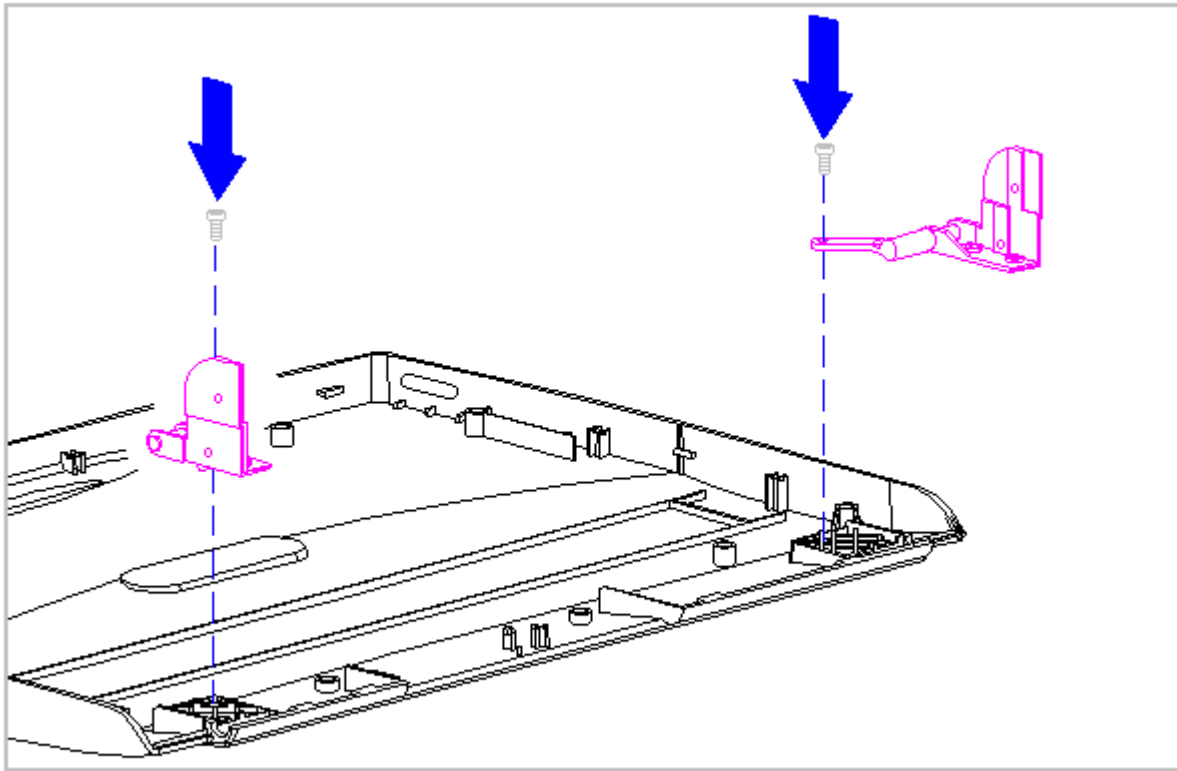

Figure 3-176. Replacing the Display Clutches (All Models)

21. Replace the display ground cable, the LCD panel, the shield, and the display cable into the display enclosure as follows:
 - If replacing a Monochrome panel and shield, refer to Section 3.22.
 - If removing a CSTN (9.5 in) panel and shield, refer to Section 3.23.
 - If removing a CTFT (8.4 in) panel and shield, refer to Section 3.24.
 - If removing a CSTN (10.4 in) panel and shield, refer to Section 3.26.
 - If removing a CTFT (10.4 in) panel and shield, refer to Section 3.27.
22. Connect the display cable and backlight cable to the inverter board (Section 3.25).
23. Replace the inverter board (Section 3.25).
24. Replace the display latches and springs (Section 3.25).
25. Replace the bezel (Section 3.25).
26. Position the display clutches at a 90-degree angle (Figure 3-177).

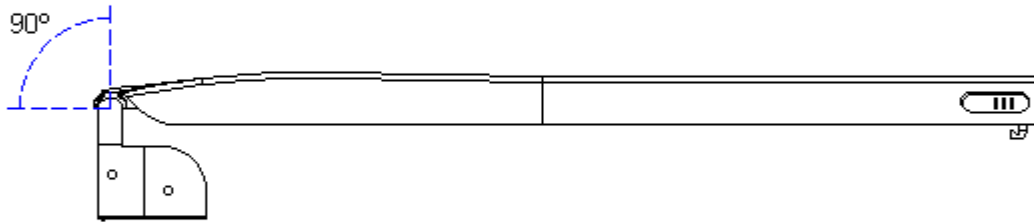

Figure 3-177. Positioning Display Clutches (All Models)

27. Align the clutches with the system unit module, ensuring that the display ground cable and the display cable are positioned on top of the system unit module (Figure 3-178).

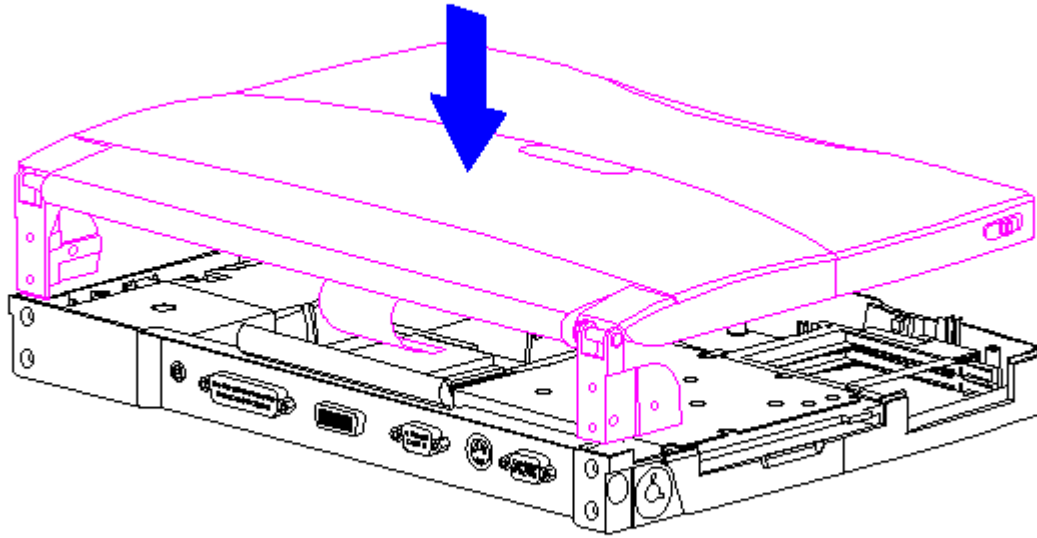

Figure 3-178. Replacing the Display Assembly (All Models)

28. Replace the four rear clutch screws (Figure 3-179).

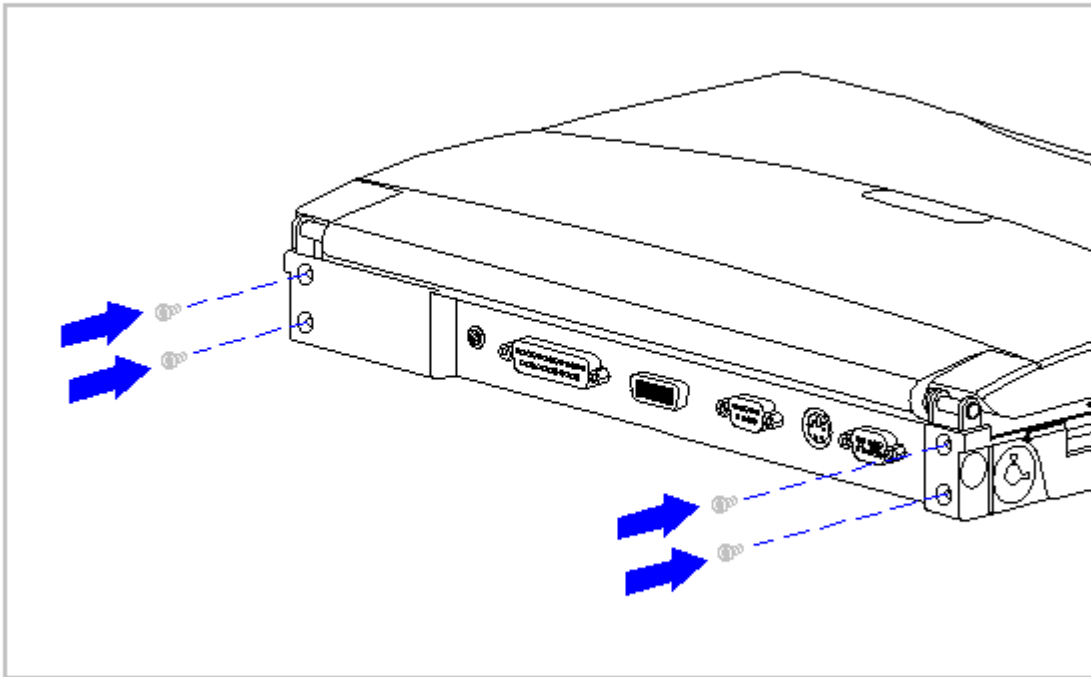

Figure 3-179. Replacing the Rear Clutch Screws (All Models)

29. Open the display to a 90-degree angle (Figure 3-180).

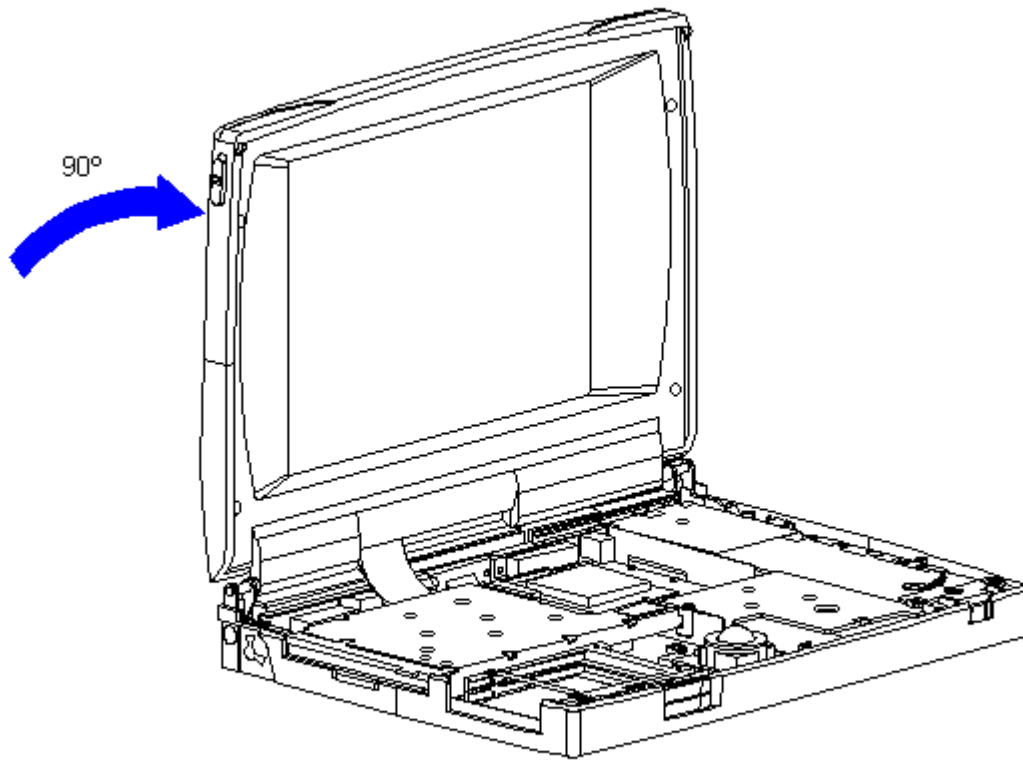

Figure 3-180. Opening the Display (All Models)

30. Connect the display ground cable [1] to the LIF clip above the serial port connector between the system board and the system chassis (Figure 3-181).

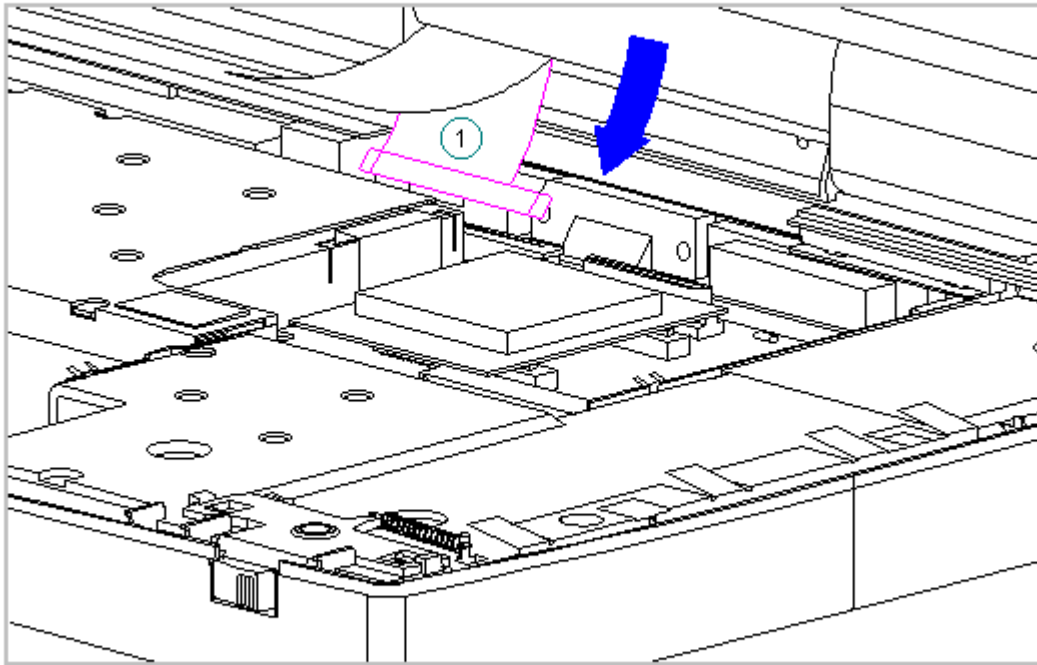

Figure 3-181. Connecting the Display Ground Cable to the LIF Clip on the System Unit Module (All Models)

31. Carefully insert the end of the cable into the ZIF connector slide on the system unit.

IMPORTANT: Ensure that the ZIF connector slide is in its fully upward position and that it remains so while you are inserting the cable into it. Before closing the slide, ensure that the cable is fully seated (to the white insertion line) in the ZIF connector.

32. While holding the end of the display cable inside the ZIF connector slide, press down both ends of the slide simultaneously to secure the cable in the ZIF connector (Figure 3-182).

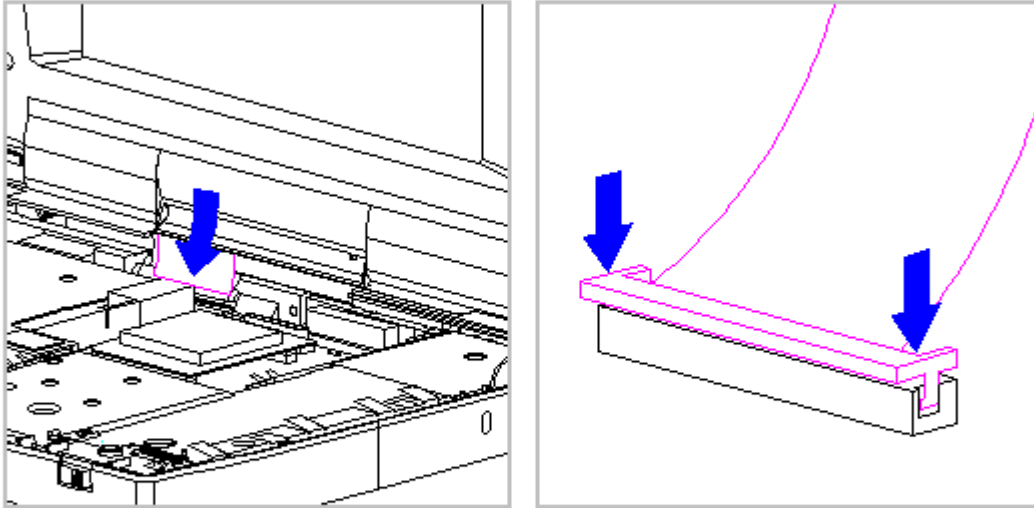

Figure 3-182. Connecting the Display Cable to the System Unit Module (All Models)

33. Ensure that the cable has been seated evenly and that the white line on the cable is level.
34. Replace the right clutch ground clip located between the clutch and the CPU base. The right clutch clip for Models 420 and 430 is different and is illustrated in the insert Figure 3-183).

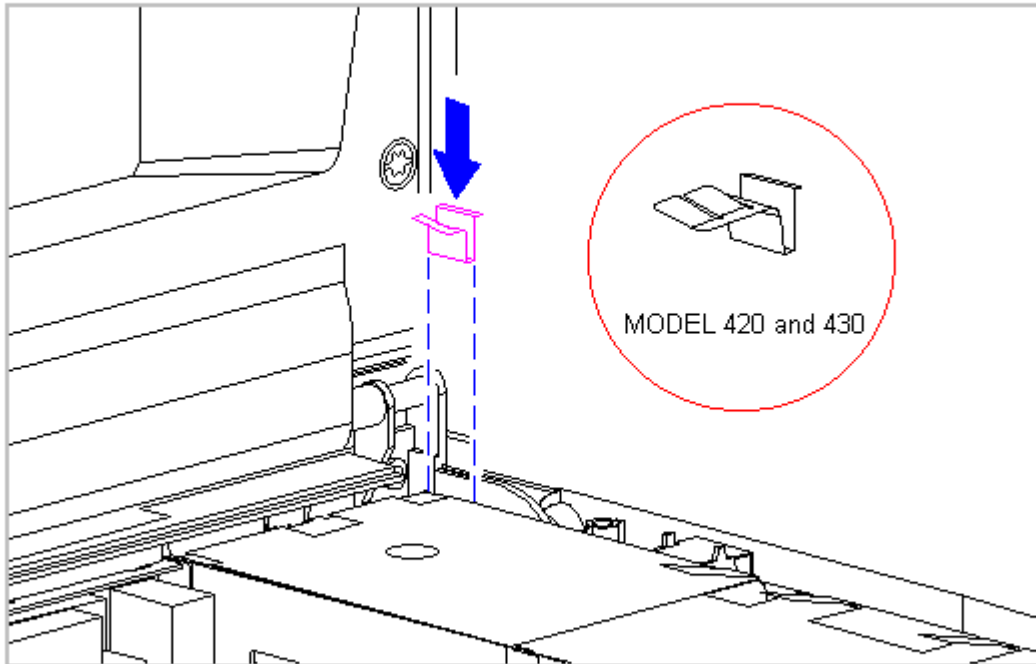

Figure 3-183. Replacing the Right Clutch Ground Clip (All Models)

35. Replace the keyboard assembly (Section 3.7).
36. Replace the tilt feet (Section 3.4).
37. Replace the handle bracket (Section 3.3).

Chapter 3.29 Clutches and Ground Clips

This section contains removal and replacement procedures for the clutch ground clips located between the system chassis and CPU base, and for the clutches that join the system unit module and the display enclosure.

Removing and Replacing the Clutch Ground Clips

To remove the left and right clutch ground clips, follow these steps:

1. Disconnect all power from the computer and remove the AC Adapter and battery pack (Section 3.2).
2. Remove the keyboard assembly (Section 3.7).
3. Remove the left clutch ground clip from the system chassis (Figure 3-184).

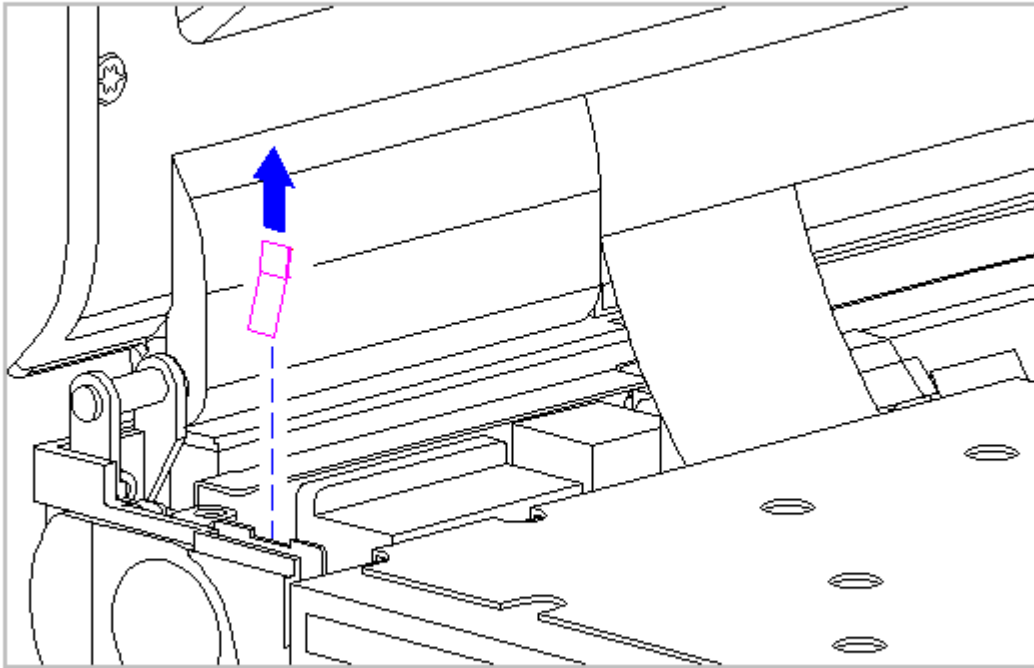

Figure 3-184. Removing the Left Clutch Ground Clip (All Models)

4. Remove the right clutch ground clip located between the clutch and the CPU base. The right clutch clip for Models 420 and 430 is different and is illustrated in the insert (Figure 3-185).

5. Remove the left and right clutch ground clips (see "Removing and Replacing Clutch Ground Clips" in this section).
6. Pull up both ends of the ZIF connector slide simultaneously [1], carefully opening the slide [2] (Figure 3-186).
7. Lift the display cable out of the connector slide [3], being careful not to pull or twist the cable (Figure 3-186).

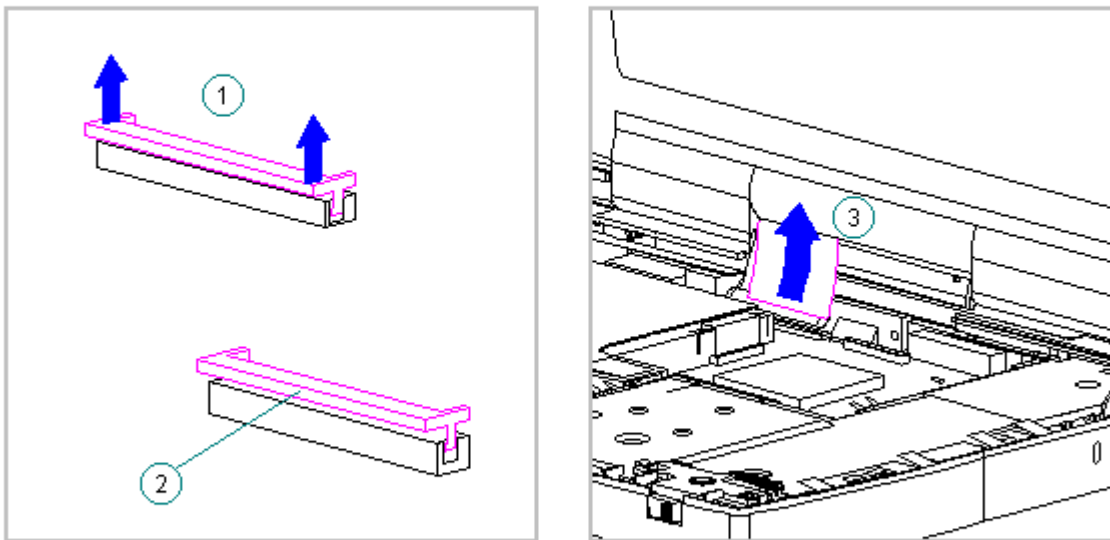

Figure 3-186. Disconnecting the Display Cable from the System Board (All Models)

8. Remove the display ground cable [1] away from the LIF clip (Figure 3-187).

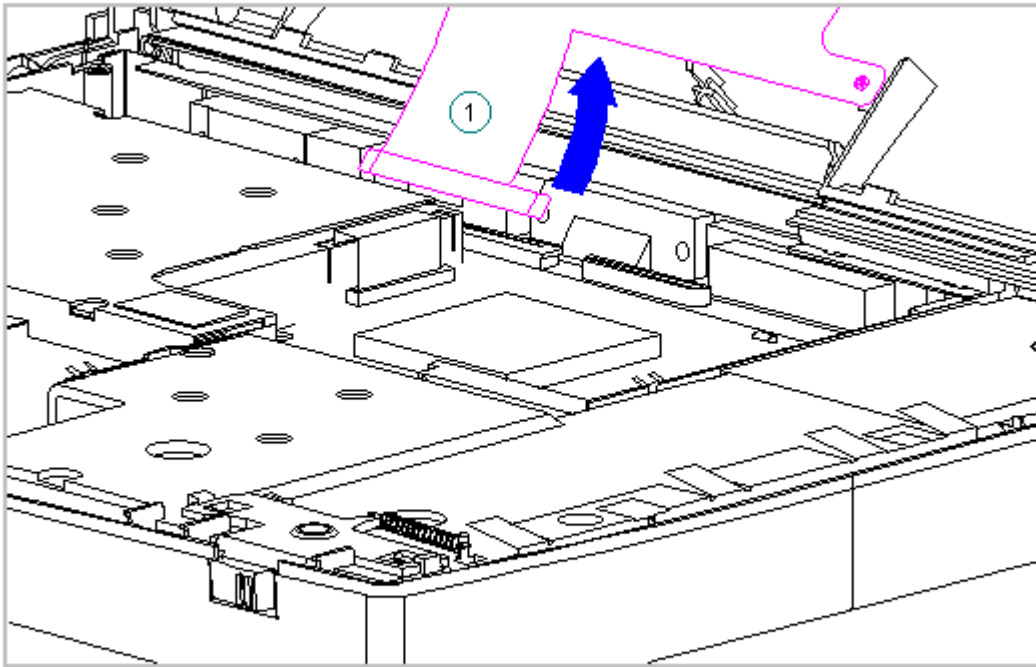

Figure 3-187. Disconnecting the Display Ground Cable from the LIF Clip (All Models)

9. Using a Torx T8 or slotted driver, remove the four clutch screws on the rear of the system unit module (Figure 3-188).

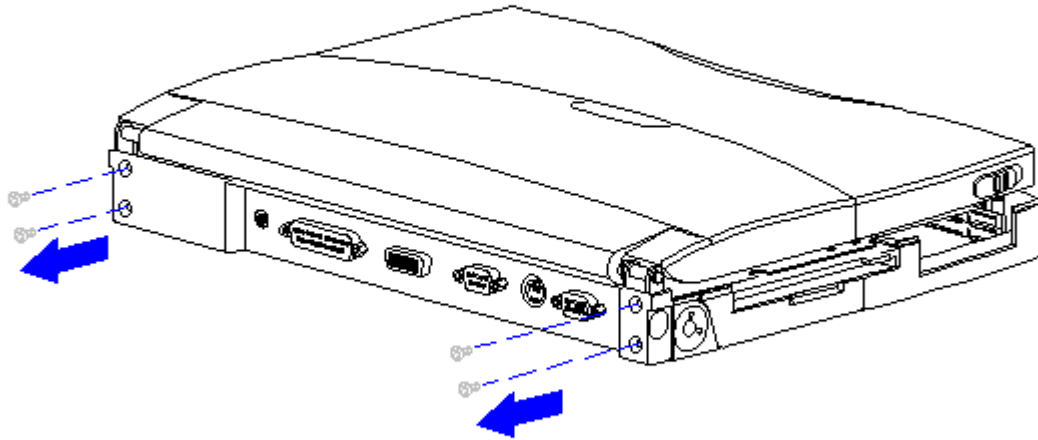

Figure 3-188. Removing the Rear Clutch Screws (All Models)

10. Lift the display assembly off the system unit module (Figure 3-189).

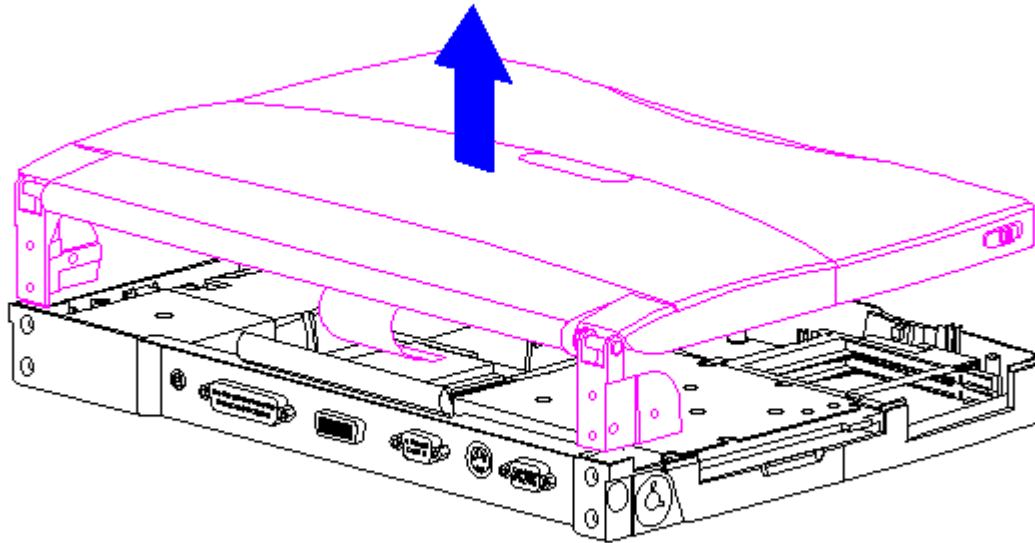

Figure 3-189. Removing the Display Assembly from the System Unit Module (All Models)

11. Place the display assembly top-side up.
12. Remove the display bezel (Section 3.21).
13. Remove the screws from the clutches on either side of the display enclosure.
14. On either side of the display enclosure, slide the clutches from underneath the display shield tabs (Figure 3-190).

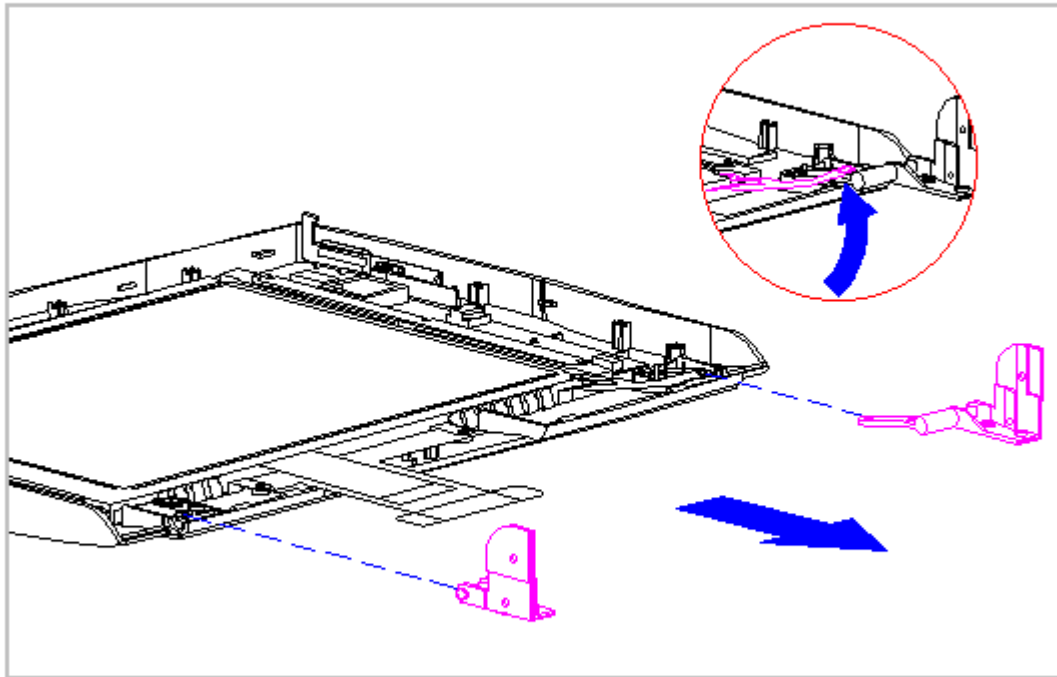

Figure 3-190. Removing the Clutches from Underneath the Display Shield (All Models)

15. Slide the clutches out of the display enclosure.

16. To replace the clutches, reverse the previous steps.

IMPORTANT: When replacing the display clutch screws, ensure proper alignment of the display clutches on either side of the display enclosure with the shield (Figure 3-191).

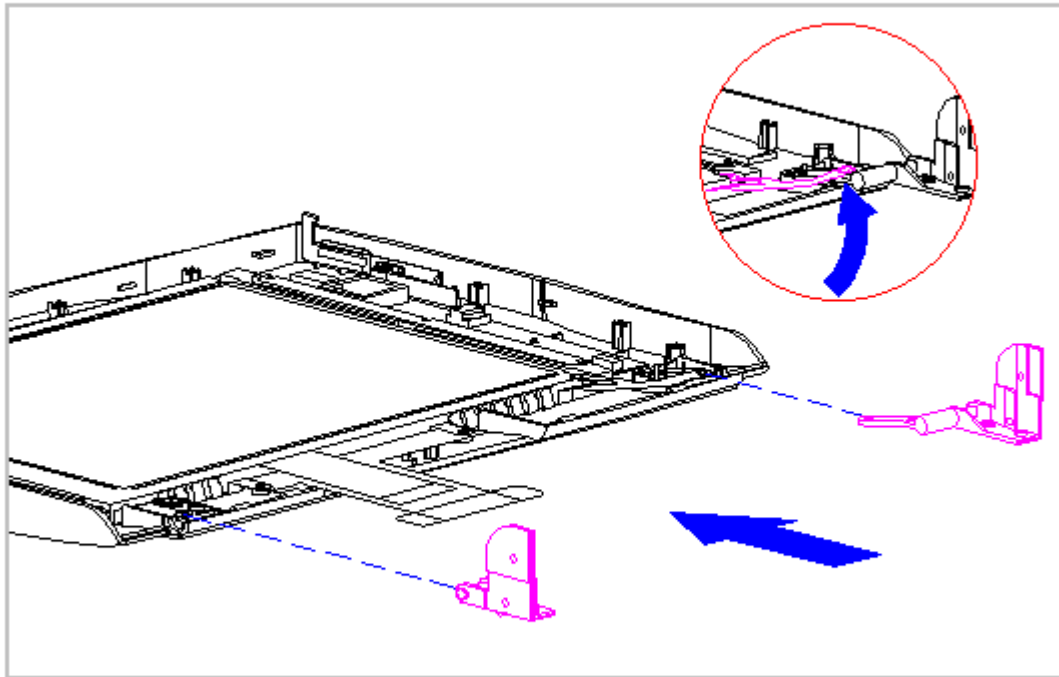

Figure 3-191. Replacing the Display Clutches (All Models)

Chapter 3.30 Docking Base

This section contains removal procedures for the following docking base components:

- o Battery Door
- o Feet
- o Handle

Removing the Battery Door

To remove the battery door, follow these steps:

1. Open the battery door until it is perpendicular to the docking base (Figure 3-192).

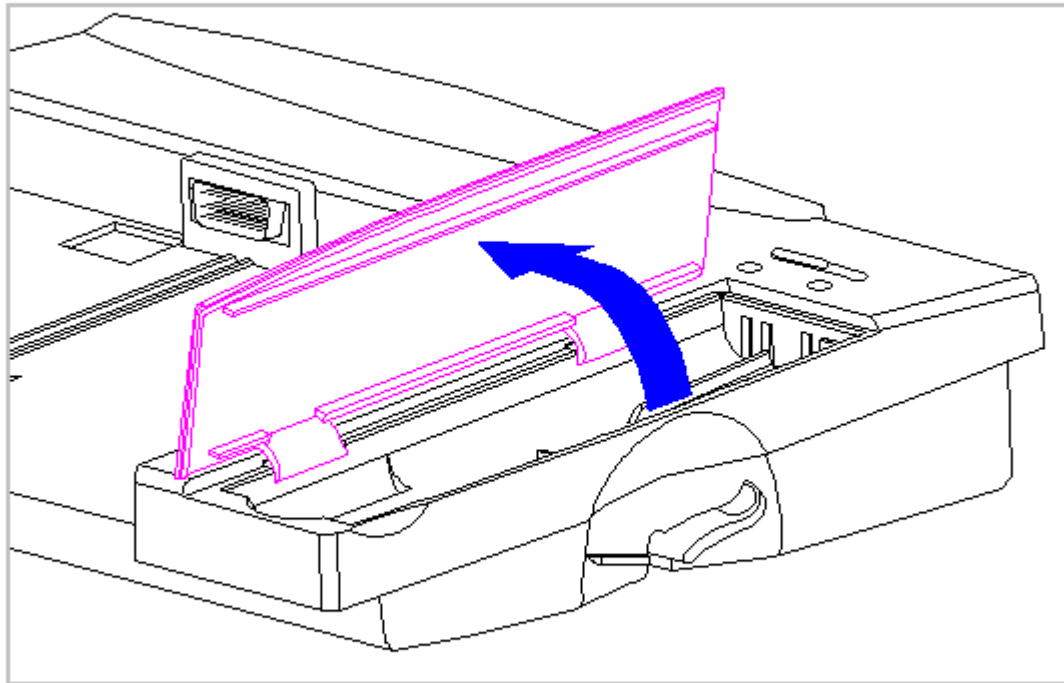

Figure 3-192. Opening the Battery Door (All Models)

2. Hold the door upright, applying pressure to the door at the base of the front hinge [1]. This creates a pivot point [2] to rotate the door out of the base (Figure 3-193).
3. Flex the front end of the door until the retaining pin [3] clears the hinge slot on the docking base (Figure 3-193).

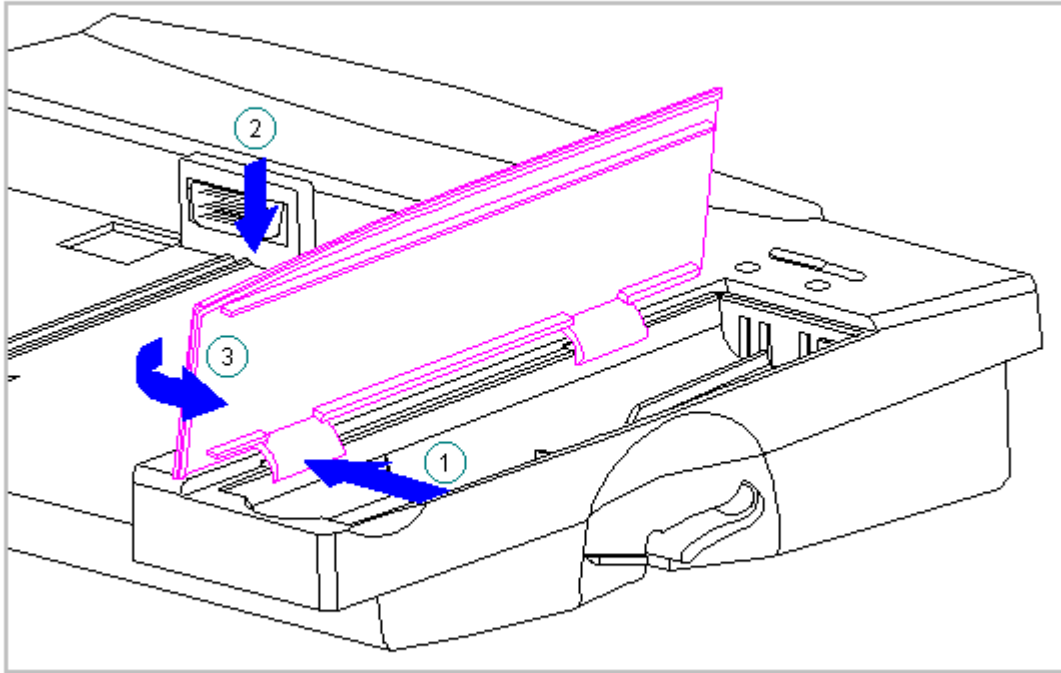

Figure 3-193. Unhinging the Battery Door from the Docking Base (All Models)

4. Remove the battery door from the docking base (Figure 3-194).

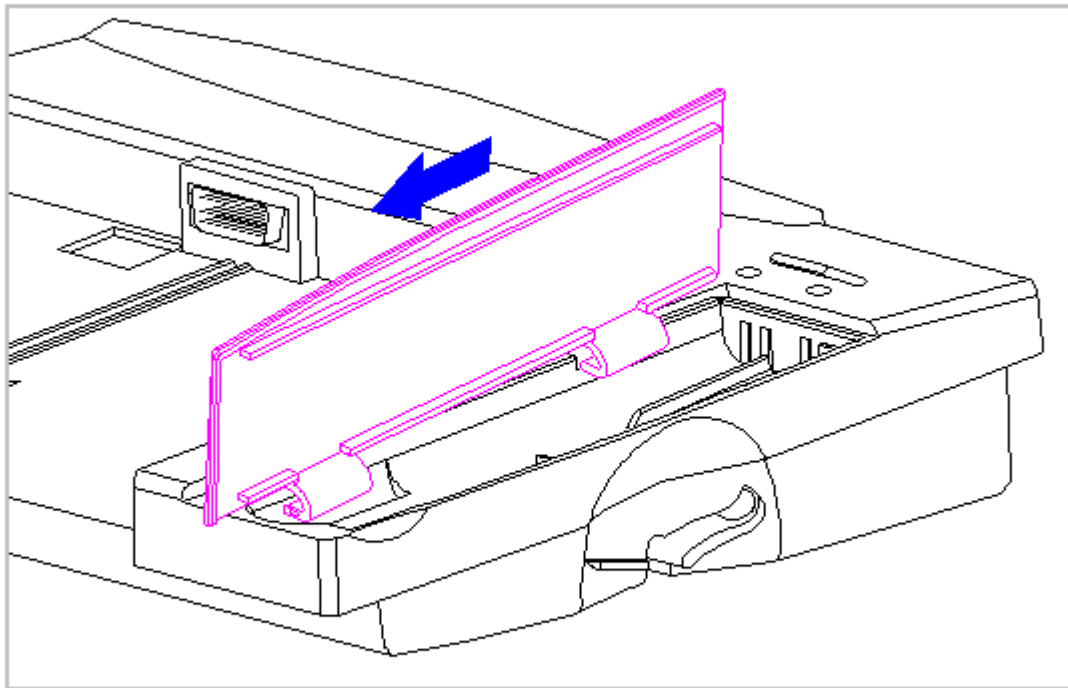

Figure 3-194. Removing the Battery Door from the Docking Base (All Models)

5. To replace the battery door, reverse the previous steps.

Replacing the Docking Base Feet

To replace the docking base feet, follow these steps:

1. Remove the top layer from the foot to expose the adhesive strip (Figure 3-195).
2. Place the foot adhesive-side down into the circular indentation on the bottom of the docking base (Figure 3-195).

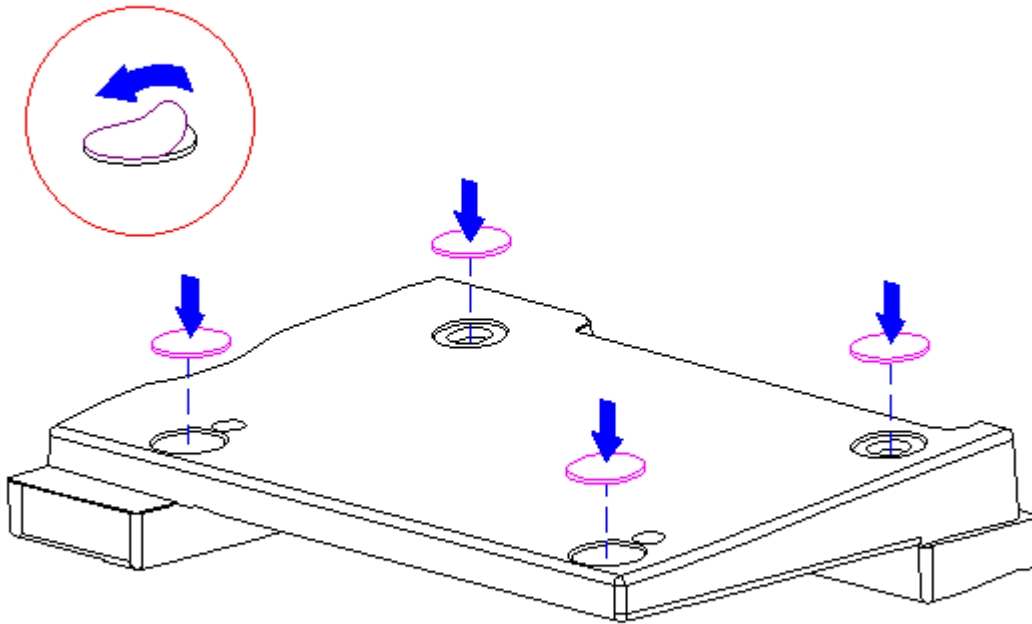

Figure 3-195. Replacing the Docking Base Feet (All Models)

Replacing the Handle

To replace the docking base handle, follow these steps:

1. Using a Torx T8, remove the screw from the rear of the handle (Figure 3-196).

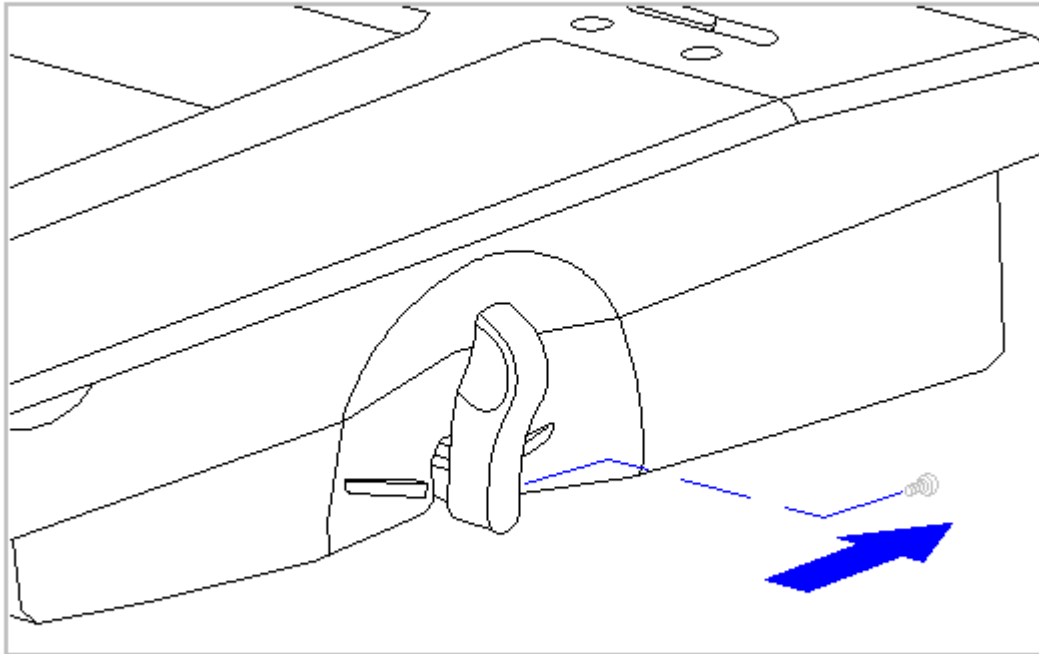

Figure 3-196. Removing the Handle Screw (All Models)

2. Slide the handle off the crankshaft (Figure 3-197).

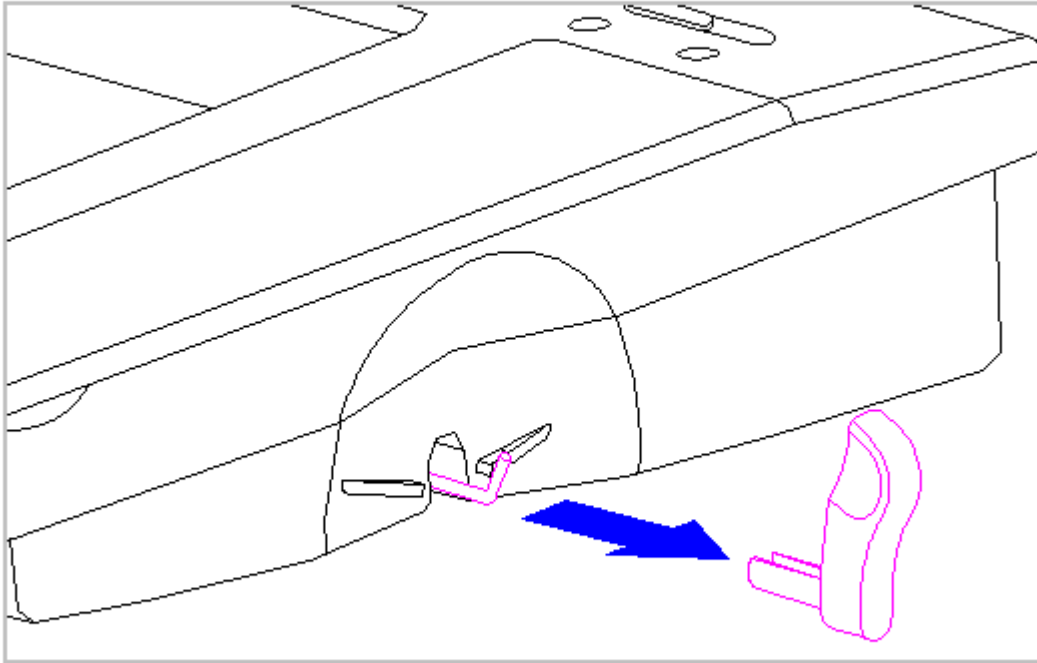

Figure 3-197. Removing the Docking Base Handle (All Models)

3. Slide the new handle on the crankshaft until the handle seats.
4. To secure the new handle to the crankshaft, replace the screw behind the handle.

Chapter 3.31 Monitor Support Cover

This section contains replacement procedures for the foot on the monitor support cover.

To replace the foot, follow these steps:

1. Turn the monitor support cover top-side down.
2. Remove the top layer from the foot to expose the adhesive strip (Figure 3-198).
3. Position the foot adhesive-side down on the exposed metal and press (Figure 3-198).

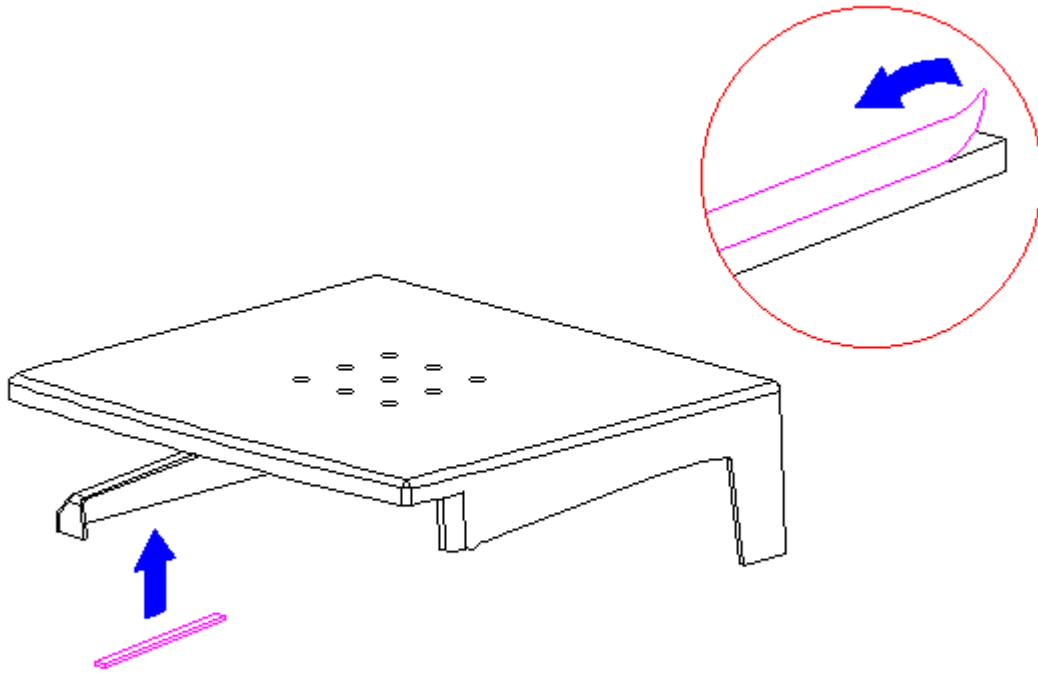

Figure 3-198. Replacing the Monitor Support Cover Foot (All Models)

Chapter 4. Running POST and Test

Introduction

This chapter covers troubleshooting information for the computer. The basic steps in troubleshooting include:

1. Follow the preliminary steps listed in Section 4.1.
2. Run the Power-On Self-Test (POST) as described in Section 4.2.
3. Run Computer Checkup (TEST) as described in Section 4.3.
4. Follow the recommended action described in the diagnostic tables in Chapter 5, Section 5.1, 5.2, and 5.3 if you are unable to run POST or Computer Checkup, or if the problem still persists after they are run.

When taking the recommended actions given in Section 5.2, 5.3, and 5.4, take them one at a time in the given order until the problem is solved and no error messages occur. Refer to Chapter 3 for any recommended removal and replacement procedures.

NOTE: If a problem only occurs when an external device is connected to the computer, the problem may be with the external device or its cable. Verify this by running POST with and without the external device connected.

Chapter 4.1 Preliminary Steps

IMPORTANT: Use AC power when running POST, Computer Setup, and Computer Checkup. A low battery condition could initiate Standby and interrupt the program.

Before running POST and Computer Checkup, complete the following preliminary steps:

1. If a power-on password has been established, type the password and press the Enter key.

NOTE: If the key symbol (ohm) appears on the screen when the computer is turned on, a power-on password has been established. If the password is unknown, it must be cleared (refer to "Clearing the Power-On Password" in this chapter).

2. Verify that Computer Setup has been run. If not, run Computer Setup.
3. Simultaneously press the Fn+F9 keys to adjust the brightness and the Fn+F8 keys to adjust contrast on the MSTN and CSTN displays.
4. Turn off the computer and external devices.

5. Disconnect any external devices that you do not want to test. (Do not disconnect the printer if you want to test it or use it to log error messages.)
6. Install loopback and terminating plugs in the serial and parallel connectors if you would like to test these ports.
7. Ensure that the hard drive is installed in the computer.
8. Connect the computer to an external AC power source with the battery pack inserted.

When the preliminary steps are complete, you are ready to run POST (Section 4.2.) and Computer Checkup (Section 4.3).

Clearing the Power-on Password

IMPORTANT: Clearing the power-on password also clears the setup password and the CMOS that contains configuration information for all external devices. After clearing the power-on password, reset the setup password and run Computer Setup to restore the configuration information.

If the password is unknown, clear it by completing the following steps:

1. Turn off the computer by simultaneously pressing the left Ctrl+Alt keys and power button.
2. Disconnect the power cord.
3. Remove the battery pack (Section 3.2).
4. Remove the keyboard cover (Section 3.7).
5. Disable the power-on password by removing the real-time clock battery as referenced in the following removal procedures:
 - Section 3.9, "Real-Time Clock Battery for Models 400 and 410"
 - Section 3.10, "Real-Time Clock Battery for Models 420 and 430"
6. Short the real-time clock battery terminals in the processor board by touching the battery terminals with two ends of a wire.
7. Replace all components.

IMPORTANT: Ensure that the battery pack is charged, since a low battery condition could initiate Hibernation and interrupt the procedure.

8. Replace the battery pack (Section 3.2).

9. Connect the power cord (Section 3.2).
10. Connect the power cord to the external outlet.
11. Turn on the computer by pressing the power button.
12. Verify that the power-on password has been cleared. If it has not been cleared, repeat steps 1 through 7. If the password is still not cleared refer to the following section for removal procedures.
 - Section 3.15, "System Board for Models 400, 410, 420 and 430"
13. Run Computer Setup to reconfigure the system.

Chapter 4.2 Power-On Self-Test (POST)

The Power-On Self-Test (POST) is a series of diagnostic tests that run automatically when the system is turned on. POST detects which type of mass storage devices are installed in the computer and checks that the following assemblies are functioning properly:

- o System board
- o Processor board
- o Memory expansion board
- o Internal keyboard controller (self-test, report error if failed)
- o External keyboard (self-test, report error if failed)
- o Display
- o Video controller circuitry
- o Trackball assembly (identifies the trackball, but no actual test)
- o Hard drive
- o Diskette drive
- o System memory

Running POST

To run POST, complete the following steps:

1. Turn off the computer by simultaneously pressing the left Ctrl+Alt keys and power button.
2. Turn on the computer.
 - If POST does not detect any errors, the computer beeps one or two times to indicate that POST has successfully run, and the computer

boots from the hard drive (or from a bootable diskette if installed in the diskette drive). However, diskette drive may be disabled, and the computer cannot boot from the diskette drive.

- If POST detects errors, the errors are indicated by screen and/or audible messages. Refer to "Power-On Self-Test (POST) Error Messages" in this section for a list of POST error messages, probable causes, and recommended actions.

3. Take the recommended action for each error code, then repeat steps 1 and 2 until POST runs successfully.

After POST runs successfully, run Computer Checkup (Section 4.3).

NOTE: If the system is not functioning well enough to run POST, or if the display is not functioning well enough to show POST error messages, refer to the troubleshooting tables in Section 5.4. Take the recommended actions, then repeat steps 1 and 2 until POST runs successfully.

Chapter 4.3 Computer Checkup (TEST)

After POST runs successfully, run the latest version of Computer Checkup (TEST). Computer Checkup determines if the computer assemblies and options are recognized by the system and functioning properly. Run Computer Checkup after installing or connecting a new assembly or option.

Computer Checkup is installed on the hard drive. If the hard drive is nonfunctional, you can run it from a diskette.

NOTE: It is recommended that you make diskette copies of Computer Checkup and keep them available for future need. A current copy can be obtained from the Compaq Customer Support Center.

Running Computer Checkup

To run Computer Checkup from the hard drive, complete the following steps:

1. Turn off the computer by simultaneously pressing the left Ctrl+Alt keys and power button.
2. Turn on the computer.
3. When the cursor moves to the right side of the screen, press F10.

The Configuration and Diagnostics menu is displayed.

4. From the Configuration and Diagnostics menu, select Computer Checkup (TEST).

A test option menu is displayed.

5. Select the option to view the device list.

A list of the installed hardware devices is displayed.

NOTE: Computer Checkup does not detect all non-Compaq devices.

6. Verify that Computer Checkup correctly detected the installed devices.

If the list is correct, select OK. The Computer Checkup option menu is displayed again.

If the list is incorrect, verify that the new devices are installed properly.

7. Select one of the following from the test option menu:
 - Quick Check Diagnostics -- This option runs a quick, general test on each device with a minimal number of prompts. If errors occur, they are displayed when the testing is complete.
 - Automatic Diagnostics -- This option runs an unattended, maximum test of each device with minimal prompts. You can choose how many times to run the tests, to stop on errors, or to print or file a log of errors.
 - Prompted Diagnostics -- This option allows maximum control over the device testing process. You can choose attended or unattended testing, decide to stop on errors, or choose to print or file a log of errors.
8. Follow the instructions on the screen as the diagnostic tests are run on the devices.

When the testing is complete, the test option menu is displayed again.

9. Exit the test option menu.
10. Exit the Configuration and Diagnostics menu.

NOTE: Exiting the Configuration and Diagnostics menu restarts the computer and saves your changes.

11. Look up the Computer Checkup error codes that were displayed by referring to "Computer Checkup (TEST) Error Codes" and take the recommended action.
12. Rerun POST and Computer Checkup, taking the recommended actions in given order until the problem is solved and no error messages occur.

Computer Checkup (TEST) Error Codes

Computer Checkup (TEST) error codes (Section 5.2) occur if the system recognizes a problem while running Computer Checkup. These error codes

help identify possible defective assemblies. Tables 5-2 through 5-13 list Computer Checkup error codes, a description of the error condition, and the recommended action for resolving the condition. For removal and replacement procedures, refer to Chapter 3.

IMPORTANT: Rerun Computer Checkup each time you complete a recommended action step. If the problem is resolved when POST and Computer Checkup are rerun (i.e., with no error codes), do not perform the remaining recommended action steps.

NOTE: The error codes in the following tables are listed in an AYY-XX format, where:

A or AA	=	Number that represents the faulty assembly.
YY	=	Test or action that failed.
XX	=	Specific problem.

Chapter 5. Error Messages and Codes

Introduction

This chapter provides tables covering possible errors messages for the Power-On Self-Test (POST) and the Computer Checkup (TEST) diagnostics.

Chapter 5.1 Power-On Self-Test (POST)

POST error messages occur when problems are discovered during POST. Table 5-1 lists visual error messages for POST, audible (beep) error messages, probable causes, and recommended actions.

Table 5-1. Power-On Self-Test Messages

Message	Beeps	Probable Cause	Recommended Action
101 - ROM Error	1 Long, 1 Short	System ROM checksum	<ol style="list-style-type: none"> 1. Inspect the ROM placement. 2. Replace the ROM. 3. Flash the ROM. 4. Replace the system board.
101 - I/O ROM Error	None	Option ROM checksum	<ol style="list-style-type: none"> 1. Inspect the ROM placement. 2. Verify the correct ROM. 3. Replace the ROM.
102 - System Board Failure	None	DMA, timers, etc. Unsupported processor upgrade installed	<ol style="list-style-type: none"> 1. Replace the processor board. 2. Replace the system board.
162 - System Options Error	2 Short	No diskette drive or mismatch in drive type	<ol style="list-style-type: none"> 1. Run Computer Setup. 2. Check diskette cable. 3. Check diskette drive.
162 - System Options Not Set	2 Short	Configuration incorrect	Run Computer Setup.
163 - Time & Date Not Set	2 Short	Invalid time or date in configuration memory	Run Computer Setup.
164 - Memory Increase Detected	2 Short	Configuration memory incorrect	The following steps apply to 164 Memory Increase Detected and 164 Memory Decrease Detected error messages:
164 - Memory Decrease Detected	2 Short	Configuration memory incorrect	<ol style="list-style-type: none"> 1. Autosetup will correct. 2. Verify that memory board is installed correctly. 3. Replace memory board. 4. Replace system board.

Message	Beeps	Probable Cause	Recommended Action
168 - CMOS CheckSUM Invalid			<ol style="list-style-type: none"> 1. Autoseup will configure to the default settings. 2. Run Computer Setup if configuration settings are other than default.
201 - Memory Error	None	RAM failure	<ol style="list-style-type: none"> 1. If installed, make sure the memory expansion board is installed correctly. 2. If installed, clean the contacts of the memory expansion board and system board. 3. Replace the memory expansion board (if applicable). 4. Make sure the memory PC card is installed correctly by running PC card service and Computer Setup. 5. Replace the memory PC card. 6. Replace the system board.
203 - Memory Address Error	None	RAM failure	See Message 201 above.
205 - Memory Error	None	Cache memory error	<ol style="list-style-type: none"> 1. Run Computer Checkup. 2. Replace the system board.
207 - Invalid Memory Configuration Module	None	Memory module installed incorrectly	Verify placement of memory.
209 - NCA RAM Error	None	RAM Failure	Run Computer Checkup.
211 - Memory Failure	None	RAM Failure	Run Computer Checkup.
301 - Keyboard Error	None	Keyboard Failure	<ol style="list-style-type: none"> 1. Check external keyboard for stuck key or loose cable. 2. Replace system board.
Message	Beeps	Probable Cause	Recommended Action
301 -	None	Keyboard Failure	1. Check external keyboard.

Keyboard Error or Text Fixture Installed			2. Replace system board.

303 - Keyboard Controller Error	None	System board keyboard controller	Replace the system board.

304 - Keyboard or System Unit Error	None	Keyboard	1. Check external keyboard. 2. Replace system board.

401 - Printer Error	None	Printer controller	Replace the system board, if applicable.

402 - Monochrome Adapter Failure	1 Long, 2 Short	Monochrome display controller	Replace the monochrome display controller.

501 - Display Adapter Failure	1 Long, 2 Short	Video display controller	Replace the display panel.

601 - Diskette Controller Error	None	Diskette controller circuitry	1. Make sure diskette drive cable is seated. 2. Replace the diskette drive cable. 3. Replace the diskette drive. 4. Replace the system board.

602 - Diskette Boot	None	Diskette in drive A not bootable	1. Replace the diskette. 2. Replace the diskette drive. 3. Replace the system board.

Message	Beeps	Probable Cause	Recommended Action

605 - Diskette Drive Error	2 Short	Mismatch in drive type	Run Computer Setup.

702 - Coprocessor Detection Error	None	Coprocessor	1. Replace the processor upgrade. 2. Replace the system board.

702A - Coprocessor Detection Error	2 Short	Coprocessor	1. Replace the processor upgrade. 2. Replace the system board.

703 - CMOS Reports A Coprocessor That Has Not	2 Short	Coprocessor or configuration error	1. Run the Configuration utility. 2. Replace the processor upgrade.

Been Detected by POST			3. Replace the system board.

1125 - Internal Serial Port Failure	2 Short	Defective internal serial port	1. Run Computer Setup and Check it. 2. Replace the system board.

1780 - Disk 0 Failure	None	Hard drive/format error	1. Run Computer Checkup. 2. Replace the drive.

1782 - Disk Controller	None	Hard drive circuitry error	1. Run Computer Checkup. 2. Replace the drive.

1790- Disk 0 Failure	None	Hard drive error or wrong drive type	1. Run Computer Setup and Computer Checkup. 2. Change drive type. 3. Replace the drive.

Audible	1 Short	Power-on successful	None.

Audible	2 Short	Power-on successful	None.

(RESUME = F1 KEY)	None	As indicated to continue	Press the F1 key.
=====			

Chapter 5.2 Computer Checkup (TEST) Error Codes

Computer Checkup (TEST) error codes occur if the system recognizes a problem while running Computer Checkup. These error codes help identify possible defective assemblies. Tables 5-2 through 5-12 list Computer Checkup error codes, a description of the error condition, and the recommended action for resolving the condition. For removal and replacement procedures, refer to Chapter 3.

IMPORTANT: Rerun Computer Checkup each time you complete a recommended action step. If the problem is resolved when POST and Computer Checkup are rerun (i.e., with no error codes), do not perform the remaining recommended action steps.

NOTE: The error codes in the following tables are listed in an AYY-XX format, where:

A or AA = Number that represents the faulty assembly.
 YY = Test or action that failed.
 XX = Specific problem.

Table 5-2. Processor Computer Checkup Error Codes

Error Code	Description	Recommended Action
101 - xx	CPU test failed	Replace the system board.
102 - xx	Coprocessor error	Replace the system board.

103 - xx	DMA page registers test failed	Replace the system board.
104 - xx	Interrupt controller master test failed	Replace the system board.
105 - xx	Port 61 error	Replace the system board.
106 - xx	Keyboard controller self-test failed	<ol style="list-style-type: none"> 1. If using an external keyboard, try another keyboard. If second keyboard passes, replace first one. 2. Replace the system board.
107 - xx	CMOS RAM test failed	Replace the system board.
108 - xx	CMOS interrupt test failed	Replace the system board.
109 - xx	CMOS clock load data test failed	Replace the system board.
110 - xx	Programmable timer load data test failed	Replace the system board.
111 - xx	Refresh detect test failed	Replace the system board.
112 - xx	Speed test slow mode out of range	Replace the system board.
113 - 01	Protected mode test failed	Replace the system board.
114 - 01	Speaker test failed	<ol style="list-style-type: none"> 1. Check system configuration to verify that speaker is enabled. 2. Replace the keyboard assembly. 3. Replace the system board.
116 - xx	Cache test failed	Replace the system board.

Table 5-3. Memory Computer Checkup Error Codes

Error Code	Description	Recommended Action
200 - xx	Invalid memory configuration	<ol style="list-style-type: none"> 1. Run Computer Setup. 2. Replace the system board.
201 - xx	Memory machine ID test failed	The following steps apply to 201 - xx through 202 - xx error codes:
202 - xx	Memory system ROM checksum failed	<ol style="list-style-type: none"> 1. Run Computer Setup. 2. Replace the system board.
203 - xx	Memory write/read test failed	The following steps apply to 203 - xx through 210 - xx error codes:

204 - xx	Memory address test failed	If you don't have a memory expansion board, replace the system board.
206 - xx	Increment pattern test failed	If you have a memory expansion board:
210 - xx	Random pattern test failed	1. Remove the memory expansion board and reinstall a new board. 2. Replace the memory expansion board.

Table 5-4. Keyboard Computer Checkup Error Codes

Error Code	Description	Recommended Action
301 - xx	Keyboard short test 8042 self-test failed	1. Check the keyboard connection. If disconnected, turn off the computer and connect the keyboard. 2. Replace the keyboard. 3. Replace the system board.
302 - xx	Keyboard long test failed	1. Check the keyboard connection. If disconnected, turn off the computer and connect the keyboard. 2. Replace the keyboard. 3. Replace the system board.
303 - xx	Keyboard indicator test, 8042 self-test failed	1. Replace the system board. 2. If an external keyboard is being used, replace the external keyboard.
304 - xx	Keyboard typematic test failed	1. Check the keyboard connection. If disconnected, turn off the computer and connect the keyboard. 2. Replace the keyboard. 3. Replace the system board.

Table 5-5. Parallel Printer Computer Checkup Error Codes

Error Code	Description	Recommended Action
401 - xx	Printer failed or not connected	The following steps apply to 401 - xx through 498 - xx error codes:
402 - xx	Printer data register failed	1. Connect the printer. 2. Check power to the printer. 3. Install the loopback connector.
403 - xx	Printer pattern test failed	4. Replace the system board.
498 - xx	Printer failed or not	

connected

Table 5-6. Diskette Drive Computer Checkup Error Codes

Error Code	Description	Recommended Action
600 - xx	Diskette ID drive types test failed	The following steps apply to 600 - xx through 698 - xx error codes: 1. Replace the diskette. 2. Check and/or replace the diskette cable. 3. Replace the diskette drive. 4. Replace the system board.
601 - xx	Diskette format failed	
602 - xx	Diskette read test failed	
603 - xx	Diskette write, read, compare test failed	
604 - xx	Diskette random seek test failed	
605 - xx	Diskette ID media failed	
606 - xx	Diskette speed test failed	
607 - xx	Diskette wrap test failed	
608 - xx	Diskette write-protect test failed	
609 - xx	Diskette reset controller test failed	
610 - xx	Diskette change line test failed	
697 - xx	Diskette type error	
698 - xx	Diskette drive speed not within limits	
699 - xx	Diskette drive/media ID error	

Table 5-7. Serial Computer Checkup Error Codes

Error Code	Description	Recommended Action
1101 - xx	Serial Port test	Replace the system board.

Table 5-8. Modem Communications Computer Checkup Error Codes

Error Code	Description	Recommended Action
1201 - xx	Modem Internal Loopback	The following steps apply to

	Test	1201 - xx through 1210 - xx error codes:
1202 - xx	Modem Timeout Test	1. Refer to modem documentation for correct setup procedures.
1203 - xx	Modem External Termination Test	2. Check the modem line. 3. Replace the modem.
1204 - xx	Modem Auto Originate Test	
1206 - xx	Dial Multifrequency Tone Test	
1210 - xx	Modem Direct Connect Test	

Table 5-9. Hard Drive Computer Checkup Error Codes

Error Code	Description	Recommended Action
1700 - xx	Hard ID drive types test failed	The following steps apply to 1700 - xx through 1799 - xx error codes:
1701 - xx	Hard drive format test failed	1. Run Computer Setup and verify drive type.
1702 - xx	Hard drive read test failed	2. Reset the hard drive.
1703 - xx	Hard drive write/read/ compare test failed	3. Try another hard drive. If first drive was defective, try to recover data.
1704 - xx	Hard drive random seek test failed	4. Replace the system board
1705 - xx	Hard drive controller test failed	
1706 - xx	Hard drive ready test failed	
1707 - xx	Hard drive recalibration test failed	
1708 - xx	Hard drive format bad track test failed	
1709 - xx	Hard drive reset controller test failed	
1710 - xx	Hard drive park head test failed	
1714 - xx	Hard drive file write test failed	
1715 - xx	Hard drive head select test failed	

1716 - xx Hard drive conditional
format test failed

1717 - xx Hard drive ECC * test
failed

1719 - x Hard drive power mode
test failed

1799 - xx Invalid hard drive
type failed

* Error Correction Code
=====

Table 5-10. Graphics Computer Checkup Error Codes
=====

Error Code	Description	Recommended Action
2402 - xx	Video memory test failed	The following step applies to 2402 - xx through 2480 - xx error codes: Replace the system board.
2403 - xx	Video attribute test failed	
2404 - xx	Video character set test failed	
2405 - xx	Video 80 x 25 mode 9 x 14 character cell test failed	
2406 - xx	Video 80 x 25 mode 8 x 8 character cell test failed	
2408 - xx	Video 320 x 200 mode color set 0 test failed	
2409 - xx	Video 320 x 200 mode color set 1 test failed	
2410 - xx	Video 640 x 200 mode test failed	
2412 - xx	Video gray scale test failed	
2414 - xx	Video white screen test failed	
2416 - xx	Video noise pattern test failed	
2418 - xx	ECG/VGC memory test failed	

2419 - xx ECG/VGC ROM checksum
test failed

2421 - xx ECG/VGC 640 x 200
graphics mode test
failed

Error Code	Description	Recommended Action
2422 - xx	ECG/VGC 640 x 350 16 color set test failed	The following step applies to 2402 - xx through 2480 - xx error codes: Replace the system board.
2423 - xx	ECG/VGC 640 x 350 64 color set test failed	
2424 - xx	ECG/VGC monochrome text mode test failed	
2425 - xx	ECG/VGC monochrome graphics mode test failed	
2431 - xx	640 x 480 graphics test failure	
2432 - xx	320 x 200 graphics (256 color mode) test failure	
2448 - xx	Advanced Graphics Controller test failed	
2451 - xx	132 - column Advanced Graphics test failed	
2456 - xx	Advanced Graphics 256 Color test failed	
2458 - xx	Advanced Graphics BitBLT test	
2468 - xx	Advanced Graphics DAC test	
2477 - xx	Advanced Graphics data path test	
2478 - xx	Advanced Graphics BitBLT test	
2480 - xx	Advanced Graphics Line draw test	

Table 5-11. Pointing Device Interface Computer Checkup Error Codes

Error Code	Description	Recommended Action
8601 - xx	Pointing Device Interface test failed.	1. Run SETUP, check trackball settings.

Computer is beeping and battery indicator is flashing.

Computer has entered a low battery condition.

Immediately save any open file(s). Then do any one of the following:

- o Connect the computer to an external power source, then charge the battery pack.
- o Replace the battery pack with a fully charged battery pack.
- o Initiate Hibernation (press the Fn key and power button simultaneously) to completely halt the power consumption on the battery pack, or initiate Standby by pressing the power button once to reduce power consumption until the battery pack can be recharged or another power source can be connected.

Problem

Probable Cause

Solution(s)

Computer turned off while left unattended. Power indicator is off.

System initiated Hibernation due to a low battery condition.

Install a fully charged battery pack or connect the computer to an external power source, then turn on the computer.

System initiated Hibernation according to Power Management settings.

Turn on the computer.

The computer has no power at all when the power switch is activated. All indicators are off. If the other indicators come on for any period of time (even for a momentary flash), this is not a "no power" problem.

Power switch not functioning.

1. Determine if the power switch is functioning by removing the battery and connecting the AC power cord to the unit.
2. Replace the keyboard assembly.

Defective keyboard assembly.

Install a new keyboard assembly.

Unit powers up from AC power, but not from the battery.

Battery not charged.

Charge the battery fully.

Defective battery.

Install another battery.

Battery contacts
not making good
contact with
battery.

Remove the keyboard
assembly and examine the
battery contacts. Ensure
that the battery is making
good contact with all 4
contacts.

Replace the system board.

Defective system
board.

Replace the system board.

Problem

Probable Cause

Solution(s)

The computer has a
crowbar condition: it
powers up for a short
period, then shuts off.
indicators flash on,
then off (this takes
place in less than 3
seconds).

Short circuit on
one of the power
supply outputs.

1. Remove the following
parts one at a time
until the short circuit
is located:

NOTE: After verifying
that a part is not the
cause of the short
circuit, reinstall it
before removing the next
part. In addition, note
that the first three
parts can be checked by
the user.

- a. PC card
- b. Battery pack
- c. Hard drive
- d. Diskette drive
- e. Internal AC power
supply

2. Disconnect the display
cable from the system
board and power the
unit up. If the unit
powers up, the display
cable or display
assembly has failed.
Plug the display cable
back into the system
board and attempt to
find the defective
part in the display
assembly by completing
the following steps
one at a time until
the short circuit is
located:

- a. Disconnect the
display cable from
the inverter board

- and attempt to power the unit up. If the unit powers up, replace the inverter board.
- b. Disconnect the display cable from the display panel and power the unit up. If the unit powers up, replace the display panel.
- c. Replace the display cable.
- 3. Replace the system board.

Table 5-13. Solving System Start Problems

Problem	Probable Cause	Solution(s)
System powers up (LEDs on) but it does not begin POST.	Bad contacts between processor board and system board.	Replace system board.
	Defective processor board.	Replace system board.
	Defective system board.	Replace system board.

Table 5-14. Solving Standby Problems

Problem	Probable Cause	Solution(s)
The power/standby button is pressed, but the unit does not go into standby.	Defective keyboard assembly.	Replace the keyboard assembly.
	Defective system board.	Replace the system board.

Table 5-15. Solving Battery Problems

Problem	Probable Cause	Solution(s)
Battery indicator flashes to indicate low battery condition, but computer does not beep.	Low battery beeps were turned off.	Use Power Management to turn on the low battery warning beeps.
	Volume is turned on/off.	Press the Fn + F5 keys.
Battery indicator doesn't light and battery pack won't fast charge.	Battery pack is already charged.	No action is necessary.
	Battery pack was	Allow time for the battery

	exposed to temperature extremes.	pack to return to room temperature.
	Battery pack is at end of its life.	Replace battery pack.
Battery charge does not last as long as expected.	Battery is being exposed to high temperatures. *	Keep computer at a cooler temperature and recharge the battery.
	Battery is being exposed to cold temperatures. *	Put computer in a warmer place and recharge the battery.
	Battery has partially self-discharged.	Recharge the battery.
	Power conservation is disabled or set to "None."	Set a power conservation level.
	An external device or PCMCIA card is draining the battery.	Turn off or remove the external device when not using it.
	Defective battery.	Condition the battery. Install another battery. If this fixes the problem, original battery is defective. Replace the battery.
Battery pack is warm to the touch after charging.	Normal warming has occurred due to charging.	No action is required.
Battery indicator does not come on and the battery gauge does not reflect a change in battery charge level.	Battery pack is trickle charging.	Allow battery pack to continue charging for 30 minutes and recheck the battery gauge.
	Battery contacts not making good contact with battery.	Remove the keyboard assembly and examine the battery contacts. Ensure that the battery is making good contact with all 4 contacts. If not, gently bend the contacts on the system board out to make good contact.
	Defective system board.	Replace the system board.

* The recommended storage temperature range for the battery pack is -4oF to 86oF (-20oC to 30oC). The recommended operating temperature range is 50oF to 104oF (10oC to 40oC).

Table 5-16. Solving Battery Gauge Problems

Problem	Probable Cause	Solution(s)
Battery gauge appears inaccurate.	Battery pack has been partially recharged too many times or computer has been in Standby for an extended period of time.	Charge the battery pack * (Appendix B). NOTE: The battery gauge is not linear. It will not necessarily stay on each indicator the same amount of time. The battery gauge is based on voltage output from the battery.

* The battery pack needs to be conditioned every 60 days to maintain battery gauge accuracy.

Table 5-17. Solving Display Problems

Problem	Probable Cause	Solution(s)
Characters are dim.	From MS-DOS: Power Management settings is set on high or custom.	From MS-DOS: Change Power Management settings to medium.
	From Windows: Power Management brightness setting is incorrect.	From Windows: Adjust brightness setting in Power Management.
	Brightness or contrast (if applicable) is not set properly.	Press the Fn + F9 keys. Use arrows keys to adjust the brightness. Press the Fn + F8 keys. Use arrows keys to adjust the contrast. NOTE: Contrast adjustment is not applicable on models with Color TFT displays.
	Computer screen is in direct light.	Tilt display or move computer.
Screen is blank.	Quick Blank is initiated.	Enter password to exit QuickBlank.
	Another screen blanking utility may be installed.	Press any key and/or enter password.
	Screen save was initiated by Power Management due to	Press any key or click the mouse.

lack of user activity.

Brightness and contrast needs adjusting.

Press the Fn + F9 keys to adjust the brightness. Use the left and right arrow keys to adjust brightness. Press the Fn + F8 keys to adjust the contrast.

Display has overheated.

If computer is in direct sunlight, move it and allow it to cool off.

Display is blank and the Power/standby indicator is flashing.

System is in Standby.

Press the Power/standby button to exit Standby.

Problem

Probable Cause

Solution(s)

Screen is blank, the Power/standby indicator is flashing, and the battery indicator is flashing.

System has entered a low battery Standby condition. The computer will next activate Hibernation, if this feature is not disabled.

If available, immediately connect the computer to an external power source or insert a charged battery pack. Then press the standby button to exit Standby.

If another power source is not immediately available and Hibernation is disabled, attempt to exit Standby and save any open files. However, the computer may not have enough power to do this.

If you have not disabled Hibernation, the computer automatically hibernates. Do not interfere with the computer while it is hibernating. Once the computer has turned off, insert a charged battery pack or connect the computer to another power source, then turn the computer back on.

Computer display is blank and the screen on an external monitor displays information.

Display function was switched to the external monitor.

Press the Fn + F4 keys to activate the computer display. Press the keys again to display information simultaneously.

**

Distorted or garbled characters on the display are mixed with text.	The ANSI.SYS driver is not in the CONFIG.SYS file or the path is incorrect.	Add the ANSI.SYS driver to the CONFIG.SYS file. Add the following line: DEVICE=C:\ANSI.SYS
---	---	---

Computer display flashes or has garbled characters when computer is connected to external monitor.	Using 800 x 600 or higher resolution on external monitor and have toggled back to internal display, which only supports 640 x 480 resolution.	Restart the computer. If simultaneous display is desired, use 640 x 480 resolution. **
--	---	--

** When using an external monitor and simultaneously displaying an image on the internal display, the image on the external monitor may not fill the screen.

Problem	Probable Cause	Solution(s)
---------	----------------	-------------

Computer display and external monitor do not display information simultaneously.	External monitor was connected after the computer was turned on.	Turn the computer off and connect the external monitor on, then turn on the computer. Press the Fn + F4 keys to "toggle" through the three display possibilities.
--	--	--

The light tubes on the edge of the display panel do not light up at all and Power-On Self-Test (POST) completes when the unit is powered up. **	External monitor was connected when the computer was turned on. Improper backlight or display cable connections.	If an external monitor is detected during POST, only the external monitor will turn on. Press the Fn + F4 keys to activate the computer display. 1. Reseat the display cable to the system board. 2. Reseat the display cable to the inverter board. 3. Reseat the backlight cable to the inverter board.
---	---	--

Defective inverter board.	Replace the inverter board.
---------------------------	-----------------------------

Defective display cable.	Replace the display cable.
--------------------------	----------------------------

Defective display panel.	Replace the display panel.
--------------------------	----------------------------

Defective system board.	Replace the system board.
-------------------------	---------------------------

The light tubes on the edge of the display panel do not	Defective system board.	Replace the system board.
---	-------------------------	---------------------------

light up at all and Power-On-Self-Test (POST) does not complete when the unit is powered up. ****

** When using an external monitor and simultaneously displaying an image on the internal display, the image on the external monitor may not fill the screen.

**** Blocks usually appear in an even fraction of the display (1/2, 1/4, 1/6, 1/8, etc.)

Problem	Probable Cause	Solution(s)
Backlight (brightness) cannot be adjusted with brightness control pop-up Fn + F9 keys. *	Power conservation mode settings are set high, causing a dim display.	Verify that you are not in a power conservation mode that limits the output of the backlight.
	Improper display cable connections.	1. Reseat the display cable to the inverter board. 2. Reseat the display cable to the system board.
	Defective inverter board.	Replace the inverter board. ***
	Defective display cable.	Replace the display cable. ***
	Defective system board.	Replace the system board. ***
Contrast cannot be adjusted with the Fn + F8 keys. *	Improper display cable connections.	Reseat the display cable to the following one at a time until the problem is solved: a. Inverter board. b. System board. c. Display panel.
	Defective inverter board.	Replace the inverter board. ***
	Defective display cable.	Replace the display cable. ***
	Defective display panel.	Replace the display panel. ***
The display panel has a continuous pattern across it (e.g., a	Improper display cable connections.	Reseat the display cable to the following until the problem is solved:

"jailbars" pattern), has a single color on it, or has garbled graphics across the entire panel. This failure is for patterns across the entire panel (not just on one section).		a. System board b. Display panel c. Inverter board
	Defective display cable	Replace the display cable.
	Defective inverter board.	Replace the inverter board.
	Defective system board.	Replace the system board.
A single line, small group of lines, or block appears on the display panel. This failure occurs in only a section of the display panel. ****	Defective display panel	Replace the display panel.
A number of single pixels are out or dots of various colors are visible on a black screen.	Acceptable according to specifications.	Check the number of pixels that are out against Compaq specifications. A certain number of pixels are allowed to be out, due to limitations in LCD technology.
	Defective display panel.	If the number of pixels that are out is beyond Compaq specifications, replace the display panel.
	Defective system board.	Replace system board.
<p>* Press the Fn + F9 keys to adjust the brightness, setting. Additionally, on the MSTN and CSTN models, press the Fn + F8 keys to adjust the contrast setting.</p> <p>** When using an external monitor and simultaneously displaying an image on the internal display, the image on the external monitor may not fill the screen.</p> <p>*** This problem indicates that the backlight or its power circuitry has failed. Since you cannot observe the POST results on the display panel when the backlight is not functioning, connect the unit to an external monitor before powering the unit up. If an external monitor is not available, verify that POST completes by listening for the single or double beep, and watching for the indicators to turn on at the top of the keyboard.</p> <p>**** Blocks usually appear in an even fraction of the display (1/2, 1/4, 1/6, 1/8, etc.).</p>		

Table 5-18. Solving Diskette/Diskette Drive Problems

Problem	Probable Cause	Solution(s)
---------	----------------	-------------

Diskette drive indicator stays on.	Diskette is damaged.	Run CHKDSK on the diskette. At the system prompt, type: CHKDSK A:
	Software program is damaged.	Check the program diskettes.
Diskette drive cannot write to a diskette.	Diskette is write-protected.	Disable the diskette's write-protect feature or use a diskette that is not write-protected.
	Computer is writing to the wrong drive.	Check the drive letter in the path statement.
	Drive error has occurred.	Run Computer Checkup.
	Diskette is not formatted.	Format the diskette.
Diskette drive cannot read a diskette.	The wrong type of diskette is being used.	Use the type of diskette required by the drive.
	Diskette has a bad sector.	Copy files to hard drive or another diskette. Reformat bad diskette.
	Drive error has occurred.	Run Computer Checkup.
	Diskette is not formatted.	Format the diskette.

Table 5-19. Solving Hard Drive Problems

Problem	Probable Cause	Solution(s)
Reading hard drive takes an unusually long time after restarting the computer.	System entered Hibernation due to low battery condition and is now exiting from it.	Give the system time to restore the previously saved data to its exact state before Hibernation.
Hard drive error occurs.	Hard drive has bad sectors or has failed.	Run Computer Checkup.
Hard drive does not work.	Hard drive is not seated properly.	Turn off and unplug the computer, remove the battery pack, and remove and then reinsert the hard drive.
	Hard drive was removed and replaced while computer was	Turn off computer then turn it on again. Before removing the hard drive,

on, in Standby, or in Hibernation. make sure computer is off, unplugged, and the battery pack is removed.

Table 5-20. Solving External Device Installation Problems

Problem	Probable Cause	Solution(s)
A new device is not recognized as part of the computer system.	Computer Setup has not been run to configure the new device.	Run Computer Setup.
	Cable(s) of new external device are loose or power cables are unplugged.	Ensure that all cables are properly and securely connected.
	Power switch of new external device was not turned on when the computer was powered up.	Turn off the computer, turn on the external device, then turn on the computer to integrate the device with the computer system.
	Device is not seated properly.	Turn off the computer and reinsert the device.

Table 5-21. Solving Keyboard/Numeric Keypad Problems

Problem	Probable Cause	Solution(s)
Embedded numeric keypad on computer keyboard is disabled.	Num Lock function is not turned on.	Press the Fn+End/Num Lock keys to enable the Num Lock function and embedded numeric keypad.
Keyboard is locked.	QuickLock is initiated.	Enter password to exit QuickLock.

Table 5-22. Solving Trackball/Mouse Problems

Problem	Probable Cause	Solution(s)
Trackball or mouse does not work.	Incorrect or no device driver is installed.	Install the device driver and add to the AUTOEXEC.BAT file or CONFIG.SYS file.
	The device driver is not installed in Windows.	Install the Compaq mouse driver in Windows.
Integrated trackball does not work.	An external pointing device is connected to the computer and the system has disabled the integrated trackball.	Disconnect the external pointing device and restart the computer.

Trackball or mouse does not work even though the device driver is in the PATH command of the AUTOEXEC.BAT file.	Mouse device driver is not activated (loaded into memory) in MS-DOS.	Enter MOUSE at the system prompt to activate the mouse device driver. Add a line in the AUTOEXEC.BAT file to automatically activate the mouse device driver each time the computer is turned on or restarted.
	Defective trackball assembly.	Replace the trackball assembly.
	Defective system board.	Replace the system board.
	Mouse device driver is not correctly installed in Windows.	From Windows, run Windows Setup and select the proper mouse driver.
Cursor skips or moves abnormally when using a trackball or mouse.	The ball, rollers, or tracking post in the trackball or mouse need cleaning.	Clean the ball in the trackball or mouse.
	Defective trackball assembly.	Replace trackball assembly.

Table 5-23. Solving Memory Problems

Problem	Probable Cause	Solution(s)
Memory count during Power-On Self-Test (POST) is incorrect.	Optional memory board is installed incorrectly, is incompatible with the computer, or is configured incorrectly.	1. Ensure that the appropriate memory board has been installed correctly. 2. Run Computer Setup
"Out of Memory" message is displayed on the screen or insufficient memory error occurs during operation.	Too many TSRs are installed.	Delete any TSR applications that you do not need.
	Memory configuration is not set up correctly.	Reconfigure the memory using MS-DOS MEMMAKER.
	System ran out of memory for the application.	1. Check the application documentation for memory requirements. 2. Increase memory.

Table 5-24. Solving PC Card Problems

Problem	Probable Cause	Solution(s)
---------	----------------	-------------

When turned on, the computer does not beep when a PC Card is inserted.

Card is not inserted properly.

Remove and reinsert the card in the correct orientation.

PC Card beeps are disabled.

From MS-DOS: Run the PCCARD utility to re-enable PC Card beeps. From Windows: Select Computer Setup from the Compaq Control Center and select the PC Card option to re-enable PC Card beeps.

Warning beeps are turned off.

Press Fn+F5 keys to turn on warning beeps.

PC Card drivers are not loaded.

Select Computer Setup from the Compaq Control Center and select the PC Card option to enable the PC Card drivers.

The PC Card slot is disabled.

From MS-DOS: Select Security Management from the Configuration and Diagnostics menu to enable the PC Card slot.

Card or card driver is not PC Card compliant.

From Windows: Select Security Management from the Compaq Control Center to enable the PC Card slot.

Contact Compaq Reseller Support for a list of PC Cards tested successfully in Compaq PC Card platforms.

The PC Card drivers (Socket Services, Card Services, Card ID) fail with error messages when the computer is turned on.

The PC Card slot is disabled.

From MS-DOS: Select Security Management from the Configuration and Diagnostics menu to enable the PC Card slot.

From Windows: Select Security Management from the Compaq Control Center to enable the PC Card slot.

Problem

Probable Cause

Solution(s)

PC Card modem or fax card does not work.

Wrong COM port being used to access the card.

From MS-DOS: Run CARDINFO to determine which COM port is assigned to the card.

From Windows: Select Computer Setup from the Compaq Control Center to

determine which COM port is assigned to the card.

The card conflicts with the system board serial device.

From MS-DOS: Run PCCARD to select a different COM port for the PC Card.

From Windows: Select Computer Setup from the Compaq Control Center, then select the PC Card option and choose a different COM port for the PC Card.

The card is not PC Card compliant.

Contact Compaq Reseller Support for a list of PC Cards tested successfully in Compaq PC Card platforms.

Modem or network PC Card does not work.

Network driver is not set up properly.

Select Computer Setup from the Compaq Control Center and select the PC Card option; then view the Online help for detailed instructions on setting up network PC Cards.

Storage PC Card does not work.

SRAM and flash memory cards require the memory card driver to be loaded.

Select Computer Setup from the Compaq Control Center; then select the PC Card option to enable the memory card driver.

Flash memory cards require the Microsoft FlashFile System to be loaded.

Select Computer Setup from the Compaq Control Center; then select the PC Card option to enable the flash file system.

Hard disks on flash mass storage cards require the PC Card ATA driver to be loaded.

Select Computer Setup from the Compaq Control Center; then select the PC Card option to enable the PC Card ATA driver.

Problem

Probable Cause

Solution(s)

You are trying to access the card using the wrong drive letter.

From MS-DOS: Run CARDINFO to determine which drive letter is assigned to the card.

From Windows: Select Computer Setup from the Compaq Control Center to see which drive letter is assigned to the card.

The card is not formatted.

From MS-DOS: For memory cards, run MEMCARD to format the card. For hard drive cards and flash mass storage cards, run ATACARD, then run FORMAT.

From Windows: Select Computer Setup from the Compaq Control Center, then select MEMCARD or ATACARD from the PC Card option.

The card is not supported.

Contact Compaq Reseller Support for a list of PC Cards tested successfully in Compaq PC Card platforms.

Table 5-25. Solving Printer Problems *

Problem	Probable Cause	Solution(s)
Printer does not print.	The device drivers for the application are not installed.	Install the correct printer drivers for the application to the CONFIG.SYS file.
	Printer that is set up for a network is not connected to the network.	Connect the printer to the network.
	Printer cable is too long, unshielded, or defective.	Replace the cable.
Printer is off-line.	Paper tray is empty.	Fill the paper tray and select Online.
Printer prints garbled information.	Correct printer drivers are not installed.	Install the correct printer driver.
	Cable is not connected properly to computer.	Connect printer cable properly to the computer.
	Printer cable is too long, unshielded, or defective.	Replace the cable.

* If you experience problems printing, run a printer self-test to determine if it is a printer-specific problem. Refer to the documentation provided with the printer and the application software.

Table 5-26. Solving Software Application Problems

Problem	Probable Cause	Solution(s)
Cannot use an application.	The application has not been added to the PATH statement.	<ol style="list-style-type: none"> 1. Add or edit the application entry in the AUTOEXEC.BAT file. 2. Run the program with the full path name.
Application fails or does not work properly.	A conflict exists between applications.	Close all applications being used.
Insufficient memory to run application.	Too many TSRs are installed.	Delete any TSR applications that are not needed.
	Application requires Windows to be run in enhanced mode.	Exit Windows and enter again using the following command to run in enhanced mode: WIN/3
	Memory configuration is not set up correctly.	Re configure the memory using MS-DOS MEMMAKER.
	System ran out of memory for the application.	<ol style="list-style-type: none"> 1. Check the application documentation for memory requirements. 2. Install additional memory.

Table 5-27. Solving Sound Problems

Problem	Probable Cause	Solution(s)
Computer does not beep after the Power-On Self-Test (POST).	Beeps have been turned off.	Press the Fn+F5 keys to turn the speaker on.

Chapter 5.4 Contacting Compaq Support

Obtain the following information before contacting Compaq Support:

- o Product name
- o Product serial number (Section 1.2)
- o Purchase date
- o Conditions under which the problem occurred
- o Any error messages that have occurred
- o Hardware configuration

- o Type of printer connected
- o Hardware/software being used
- o Printed results of Computer Checkup (TEST) and View System Information (INSPECT), if possible
- o Printed copies of CONFIG.SYS and AUTOEXEC.BAT files, if possible

Chapter 5.5 Shipping Preparation

To ship the computer, complete the following steps:

1. Back up the critical hard drive files. Ensure that backup tapes/diskettes are not exposed to electrical or magnetic fields while stored or in transit.
2. Turn off the computer and external devices.
3. Disconnect the external devices from their power sources, then from the computer.

IMPORTANT: Ensure that there is no diskette in the diskette drive and that there are no PC Cards in the PC Card slot.

4. Close the display and all exterior doors (external options, PC Card compartment, memory, and hard drive).
5. Pack the computer system with sufficient packing material to protect it. Use the original packing box or similar packaging.

Chapter 6. Specifications

Introduction

This chapter provides physical, environmental, and performance specifications for the computer and its subassemblies including the following:

- o Monochrome STN display
- o Color STN and TFT displays
- o Hard drives
- o Diskette drive
- o NiMH battery pack
- o AC Adapter
- o Docking Base

Chapter 6.1 Computer

Table 6-1. Computers Models 400 and 410

	English	Metric
=====		
Dimensions Online		
Monochrome (9.5 inch):		
Height	1.8 in	4.57 cm
Width	11.9 in	30.20 cm
Depth	8.9 in	22.70 cm
Weight (w/o battery)	5.6 lbs	2.53 kg
Weight (with battery)	5.95 lbs	2.69 kg
Color STN (9.5 inch):		
Height	8.9 in	22.70 cm
Width	11.9 in	30.20 cm
Depth	2.0 in	5.08 cm
Weight (w/o battery)	5.9 lbs	2.67 kg
Weight (with battery)	6.25 lbs	2.83 kg
Color TFT (8.4 inch):		
Height	8.9 in	22.70 cm
Width	11.9 in	30.20 cm
Depth	2.0 in	5.08 cm
Weight (w/o battery)	5.9 lbs	2.67 kg
Weight (with battery)	6.25 lbs	2.83 kg

Stand-alone (Battery)		
Power Requirements:		
Nominal Operating Voltage	10.8 V	
Nominal Operating	11.0 W	
Peak Operating	24.0 W	

 Environmental Requirements

Temperature:
 Operating 50oF to 104oF 10oC to 40oC
 Nonoperating -4oF to 140oF -20oC to 60oC

Relative Humidity:
 (noncondensing)
 Operating 10% to 90%
 Nonoperating 5% to 95%

Maximum Altitude:
 (nonpressurized)
 Operating 10,000 ft 3658 m
 Nonoperating 30,000 ft 12192 m

 Shock and Vibration

Shock:
 Operating 10 g, 11 ms, half sine
 Nonoperating 60 g, 11 ms, half sine

Vibration:
 Operating 0.25 g, 5-500 Hz 1/2 octave/min
 sweep, 1 hour duration
 Nonoperating 1.00 g, 5-500 Hz 1/2 octave/min
 sweep, 1 hour duration

=====
 Table 6-2. Computers Models 420 and 430

	English	Metric
=====		
Dimensions (display size)		
Color STN (10.4 inch):		
Height	2.20 in	5.49 cm
Width	11.90 in	30.29 cm
Depth	8.90 in	22.83 cm
Weight (w/o battery)	5.9 lbs	2.67 kg
Weight (with battery)	6.25 lbs	2.83 kg
Color TFT (10.4 inch):		
Height	2.20 in	5.49 cm
Width	11.90 in	30.29 cm
Depth	8.90 in	22.83 cm
Weight (w/o battery)	5.9 lbs	2.67 kg
Weight (with battery)	6.25 lbs	2.83 kg

 Stand-alone (Battery)

Power Requirements:
 Nominal Operating Voltage 10.8 V
 Nominal Operating 11.0 W
 Peak Operating 24.0 W

 Environmental Requirements

Temperature:
 Operating 50oF to 95oF 10oC to 35oC
 Nonoperating -4oF to 140oF -20oC to 60oC

Relative Humidity
 (noncondensing):

Operating	10% to 90%
Nonoperating	5% to 95%

Maximum Altitude (unpressurized):		
Operating	10,000 ft	3658 m
Nonoperating	30,000 ft	12192 m

Shock and Vibration

Shock:	
Operating	10 g, 11 ms, half sine
Nonoperating	60 g, 11 ms, half sine
Vibration:	
Operating	0.25 g, 5-500 Hz 1/2 octave/min sweep, 1 hour duration
Nonoperating	1.00 g, 5-500 Hz 1/2 octave/min sweep, 1 hour duration

Chapter 6.2 Displays

Table 6-3. Monochrome (9.5 inch) Display Models 400 and 410

	English	Metric
Dimensions (display size):		
Height	5.7 in	14.4 cm
Width	7.6 in	19.2 cm
Mounting	Internal	
Gray Scales	16 shades	
Contrast Ratio	18:1	
Brightness	70 CD/MU2	
Pixel Size:		
Pitch	0.3 x 0.3 mm	
Format	640 x 480	
Backlight	CCFT-Edgelit at the Top and Bottom	
Character Display	80 x 25	
Total Power Consumption	3.0 W	
Frequency:		
Horizontal	31.2 kHz (CRT mode) 32 kHz (LCD mode)	
Vertical	60 Hz (VGA) 70 Hz (CGA)	
Display Inverter Board:		
Input Voltage	+5 Vdc, +18 Vdc	
Output Voltage	340 Vac	
Maximum Input Power	2.0 W	
Maximum Output Power	1.4 W	

Table 6-4. Color STN (9.5 inch) Display Models 400 and 410

	English	Metric
Dimensions (display size):		
Height	5.7 in	14.4 cm
Width	7.6 in	19.2 cm
Mounting	Internal	
Number of Colors	256 Colors	
Color Palette	4096	
Contrast Ratio	18:1	
Brightness	70 CD/MU2	
Pixel Size:		
Pitch	0.3 x 0.3 mm	
Format	640 x 480	
Configuration	RGB Stripe	
Backlight	CCFT-Edgelit at Top	
Character Display	80 x 25	
Total Power Consumption	4 W	
Frequency:		
Horizontal	31.2 kHz (CRT mode) 32 kHz (LCD mode)	
Vertical	60 Hz (VGA) 70 Hz (CGA)	
Display Inverter Board:		
Input Voltage	+5 Vdc, +18 Vdc	
Output Voltage	500 Vac	
Maximum Input Power	3.5 W	
Maximum Output Power	2.5 W	

Table 6-5. Color TFT (8.4 inch) Display Models 400 and 410

	English	Metric
Dimensions (Display Size):		
Height	5.1 in	12.9 cm
Width	6.7 in	17.1 cm
Mounting	Internal	
Number of Colors	256 Colors	
Color Palette	27000	
Contrast Ratio	100:1	
Brightness	70 CD/MU2	

Pixel Size:	
Pitch	0.27 x 0.27 mm
Format	640 x 480
Configuration	RGB Stripe

Backlight	CCFT-Edgelit at Top

Character Display	80 x 25

Total Power Consumption	4 W

Frequency:	
Horizontal	31.2 kHz (CRT mode) 32 kHz (LCD mode)
Vertical	60 Hz (VGA) 70 Hz (CGA)

Display Inverter Board:	
Input Voltage	+5 Vdc, +18 Vdc
Output Voltage	500 Vac
Maximum Input Power	3.5 W
Maximum Output Power	2.5 W
=====	

Table 6-6. Color STN (10.4 inch) Display Models 420 and 430

	English	Metric

Dimensions (Display Size):		
Height	6.33 in	16.08 cm
Width	8.43 in	21.41 cm

Mounting	Internal	

Number of Colors	256 Colors in 640 x 480 resolution	

Color Palette	4096	

Contrast Ratio	20:1	

Brightness	70 CD/MU2	

Pixel Size:	640 x 480	
Pitch	0.33 mm	
Format	RGB Stripe	
Configuration	Stripe	

Backlight	CCFT-Edge light	

Character Display	80 x 25	

Total Power Consumption	4.0 Watts (Max)	

Frequency:		
Horizontal	31.2 kHz (CRT mode) 32 kHz (LCD mode)	
Vertical	60 Hz (VGA) 70 Hz (CGA)	

Display Inverter Board:		
Input Voltage	+5 Vdc, +18 Vdc	

Output Voltage	500 Vac
Maximum Input Power	3.5 W
Maximum Output Power	2.5 W

Table 6-7 Color TFT (10.4 inch) Display Models 420 and 430

	English	Metric
Dimensions (display size):		
Height	6.335 in	16.09 cm
Width	8.365 in	21.25 cm
Mounting	Internal	
Number of Colors	256 in 640 x 480 resolution	
Color Palette	256 K	
Contrast Ratio	100:1	
Brightness	70 CD/MU2	
Pixel Size:	640 x 480	
Pitch	0.33 mm	
Format	RGB Stripe	
Configuration	Stripe	
Backlight	CCFT-Edge light	
Character Display	80 x 25	
Total Power Consumption	4 Watts (Max)	
Frequency:		
Horizontal	31.2 kHz (CRT mode) 32.0 kHz (LCD mode)	
Vertical	60 Hz (VGA) 70 Hz (CGA)	
Display Inverter Board:		
Input Voltage	+5 Vdc, +18 Vdc	
Output Voltage	500 Vac	
Maximum Input Power	3.5 W	
Maximum Output Power	2.5 W	

Chapter 6.3 Hard Drives

Table 6-8a. Hard Drives

Model	170 MB	250 MB	350 MB
Formatted Capacity			
Per Drive (MB):			
Physical	170.9	256.0	351.9
Logical	170.0	256.0	351.9

Drive Type	65 (soft)	65 (soft)	65 (soft)

Drive Height:			
With drive frame	12.7 mm	12.7 mm	12.7mm

Drive Size:			
Inches	2.5 x 0.5	2.5 x 0.5	2.5 x 0.5
Centimeters	6.3 x 1.3	6.3 x 1.3	6.3 x1.3

Transfer Rate:			
Media (Mb/s)	21.07 to 35.9	21.07 to 35.9	26.9 to 39.5
Interface (MB/s)	4.0	4.0	11.1

Sector Interleave	1:1	1:1	1:1

Typical Seek Time (including settling):			
Single Track (ms)	5.0	5.0	4.0
Average (ms)	17.0	17.0	14.0
Full Stroke (ms)	24.0	24.0	24.0

Disk Rotational Speed	4500 rpm	4500 rpm	4000 rpm

Physical Configuration:			
Cylinders	1704	1704	3477
Data Heads	4	4	2
Sectors/Track	54 to 92	54 to 92	80 to 120
Bytes/Sector	512	512	512

Logical Configuration:			
Cylinders	538	723	682
Data Heads	10	11	16
Sectors/Track	16	63	63
Bytes/Sector	512	512	512

Buffer Size (KB)	96	96	64
=====			

Table 6-8b. Hard Drives

Model	420 MB	540 MB	720 MB
=====			
Formatted Capacity Per Drive (MB):			
Physical	421.1	541.9	722.5
Logical	421.1	541.9	722.5

Drive Type	65 (soft)	65 (soft)	65 (soft)

Drive Height:			
With drive frame	12.7 mm	12.7 mm	12.7 mm

Drive Size:			
Inches	2.5 x 0.5	2.5 x 0.5	2.5 x 0.5
Centimeters	6.3 x 1.3	6.3 x 1.3	6.3 x 1.3

Transfer Rate:			

Media (Mb/s)	19 to 33	26.9 to 39.5	26.9 to 39.5
Interface (MB/s)	11.1	11.1	11.1

Sector Interleave	1:1	1:1	1:1

Typical Seek Time (including settling):			
Single Track (ms)	3.0	4.0	4.0
Average (ms)	13.0	14.0	14.0
Full Stroke (ms)	21.0	24.0	24.0

Disk Rotational			
Speed	3600 rpm	4000 rpm	4000 rpm

Physical			
Configuration:			
Cylinders	2393	3477	3477
Data Heads	4	3	4
Sectors/Track	60 to 107	80 to 120	80 to 120
Bytes/Sector	512	512	512

Logical			
Configuration:			
Cylinders	816	1050	1400
Data Heads	16	16	16
Sectors/Track	63	63	63
Bytes/Sector	512	512	512

Buffer Size (KB)	64	64	64
=====			

Chapter 6.4 Diskette Drive

Table 6-9. Diskette Drive (All Models)

=====	
Diskettes:	
Size	3.5 in (8.8 cm)
High Density (MB)	1.44
Low Density (KB)	720

LED Indicator	Green

Height	One-third

Sectors per Track:	
High Density	18
Low Density	9

Tracks per Side:	
High Density	80
Low Density	80

Transfer Rate:	
Media (Mb/s)	
Interface (MB/s)	

Cylinder:	
High	

Low

Rotational Speed	300 rpm
Read/Write Heads	2
Average Access Time (ms):	
Track-to-Track (high/low)	3/3
Average (high/low)	94/94
Settling Time (ms)	15
Latency Average (ms)	100

Chapter 6.5 Nickel Metal Hydride (NiMH) Battery Pack

Table 6-10. Battery Pack (All Models)

	English	Metric
Dimensions:		
Height	0.7 in	1.8 cm
Length	8.2 in	20.8 cm
Width	2.0 in	5.2 cm
Weight	1.0 lb	0.4 kg
Energy:		
Rated Capacity	10.8 V dc	
Nominal Open Circuit Volt.	12.0 V dc	
Rated Capacity	2.4 Ah	
Standard Recharge Rate	15 W Max. 7 W Min.	
Battery Life *	4 to 6 h	
Environmental Requirements		
Temperature:		
Operating	50oF to 104oF	10oC to 40oC
Storage		
No time limit	-4oF to 86oF	-20oC to 30oC
No longer than 3 months	-4oF to 104oF	-20oC to 40oC
No longer than 1 month	-4oF to 122oF	-20oC to 50oC

* Battery life is based on an estimated typical use pattern of an average user and will vary based on the configuration of the computer and the usage pattern of the individual user. To maximize battery life, Compaq recommends that power conservation be set to high.

Chapter 6.6 AC Adapter

Table 6-11. AC Adapter (All Models)

	English	Metric
Dimensions:		

Height	1.3 in	3.3 cm
Depth	3.0 in	7.6 cm
Width	5.0 in	12.7 cm

Weight (without cords)	6 oz	0.227 kg

Power Supply Ratings:		
Voltage Range	100-120 220-240 V	100-120 220-240 V
Input Current	0.8A/0.4 A	0.8A/0.4 A
Input Frequency	50 - 60 Hz	50 - 60 Hz
Maximum Output Voltage	16.5 V dc	16.5 V dc
Maximum Output Current	2.6 A	2.6 A
Maximum Output Power	27 W	27 W
Maximum Transient	1 kV for 50 nx	1 kV for 50 nx

Minimum Charge Time	1.0 hr	1.0 hr
=====		

Chapter 6.7 Docking Base

Table 6-12. Docking Base (All Models)

	Without Monitor Support Cover	With Monitor Support Cover
=====		
Dimensions:		
Height	2.75 in (7 cm)	3.875 in (10 cm)
Width	15.75 in (30 cm)	17.5 in (34 cm)
Depth	11.75 in (40 cm)	13.5 in (44 cm)

Weight	59.13 oz (1.7 kg)	130.86 oz (3.7 kg)

Power Supply:		
Input Voltage	18.5 Vdc Maximum	
Input Power	27 W Maximum	

Environmental Requirements		
Temperature:		
Operating	50oF to 104oF	10oC to 40oC
Nonoperating	-7.6oF to 140oF	-20oC to 60oC
Relative Humidity:		
Operating	10% to 90%, noncondensing	
Nonoperating	5% to 95%, noncondensing	

Shock and Vibration		
Shock:		
Operating	10 g, 11 ms, half sine	
Nonoperating	60 g, 11 ms, half sine	
Vibration:		
Operating	0.25 g, 5-500 Hz/octave/min sweep	
Nonoperating	1.00 g, 5-500 Hz/octave/min sweep	

Maximum Unpressurized Altitude:		
Operating	10,000 ft	3658 m
Nonoperating	40,000 ft	15750 m
=====		

Free Manuals Download Website

<http://myh66.com>

<http://usermanuals.us>

<http://www.somanuals.com>

<http://www.4manuals.cc>

<http://www.manual-lib.com>

<http://www.404manual.com>

<http://www.luxmanual.com>

<http://aubethermostatmanual.com>

Golf course search by state

<http://golfingnear.com>

Email search by domain

<http://emailbydomain.com>

Auto manuals search

<http://auto.somanuals.com>

TV manuals search

<http://tv.somanuals.com>