

# PLAYSKOOL®

## Ride2Roll™ Scooter

Thank you for buying this PLAYSKOOL brand product!

**!** **CAUTION:** This product contains small parts which are necessary for assembly. Prior to and during assembly of this product, keep small parts out of children's reach. Small parts pose a choking hazard to children under 3 years.

**!** **WARNING:** Adult supervision required. This ride-on toy is not to be used near swimming pools, on or near hills, roadways or stairways. Shoes must be worn at all times when riding this toy. Designed for only one rider at a time.

**!** **CAUTION:** Always wear protective equipment including helmet, wrist guards, knee pads and elbow pads (not included). Close-toed shoes or sneakers must be worn.

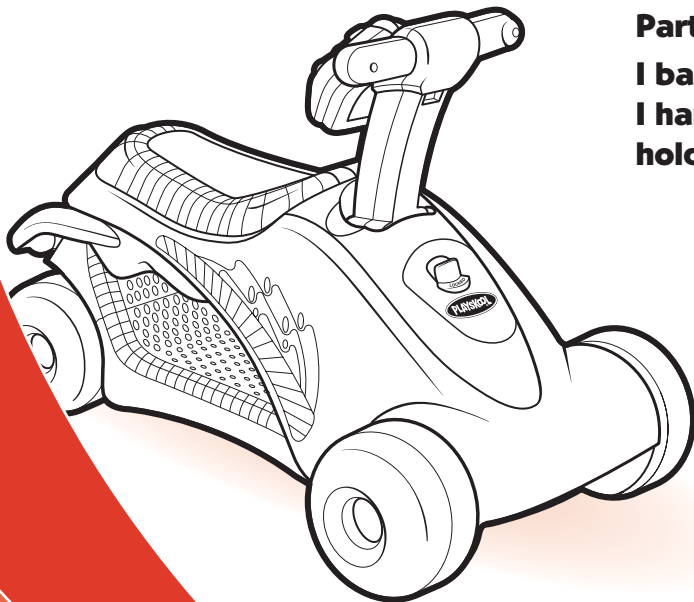

**Parts include:**

**1 base, 1 end piece, 1 vehicle body, 4 wheels, 1 axle, 1 handlebar section, 1 dashboard unit, 1 dashboard holder, 1 bag of screws, 2 labels.**

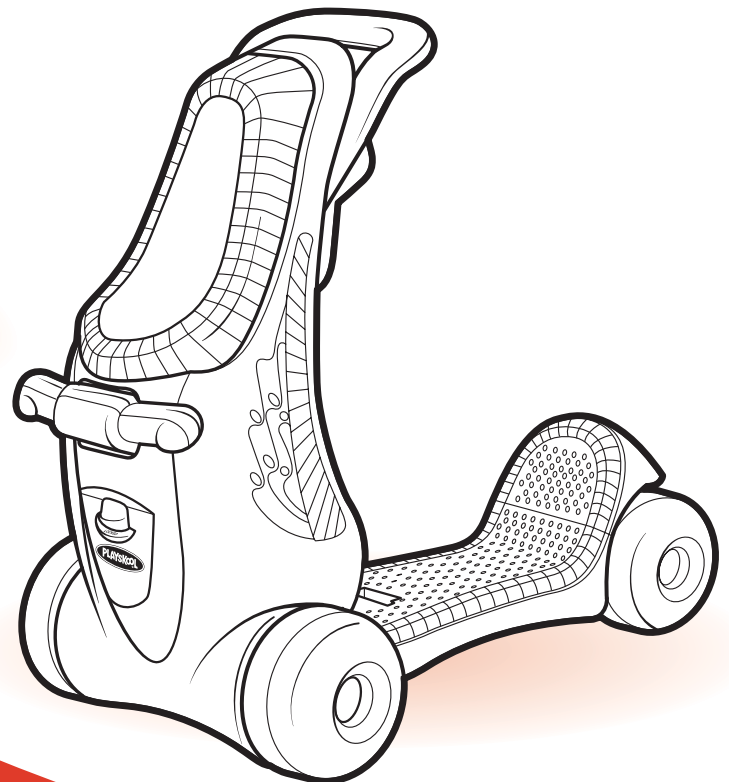

**Adult assembly  
required.**

**MAXIMUM WEIGHT  
60 LBS. (27.2 KGS.)**

## ASSEMBLY

### 1. Attach End piece to Base

Fit end piece onto base. From underside of base, tighten 2 screws into base and end piece.

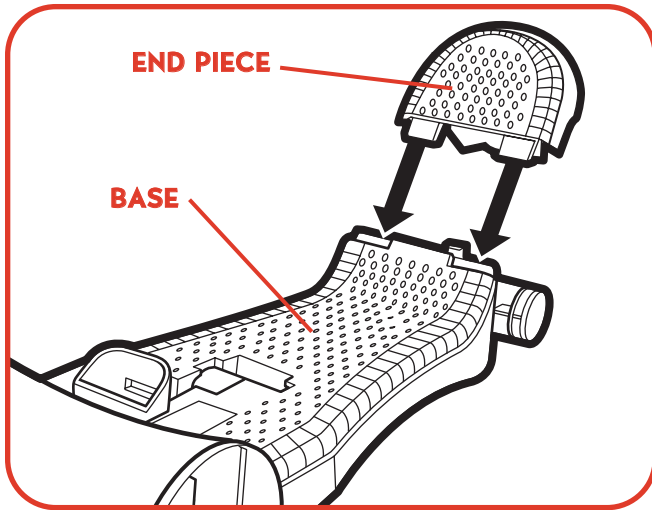

### 2. Attach Dashboard Holder to Vehicle Body

Fit dashboard holder onto vehicle body (align 3 tabs on holder with slots on body). Tighten 6 screws into dashboard holder and vehicle body.

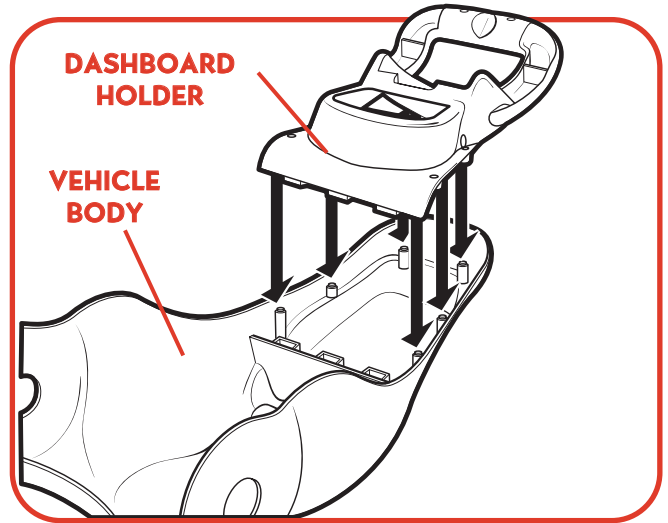

### 3. Attach Vehicle Body and Axle to Base

Fit vehicle body onto base (align holes in body with holes in base). Insert axle through holes. From underside of vehicle, tighten screw into axle and base.

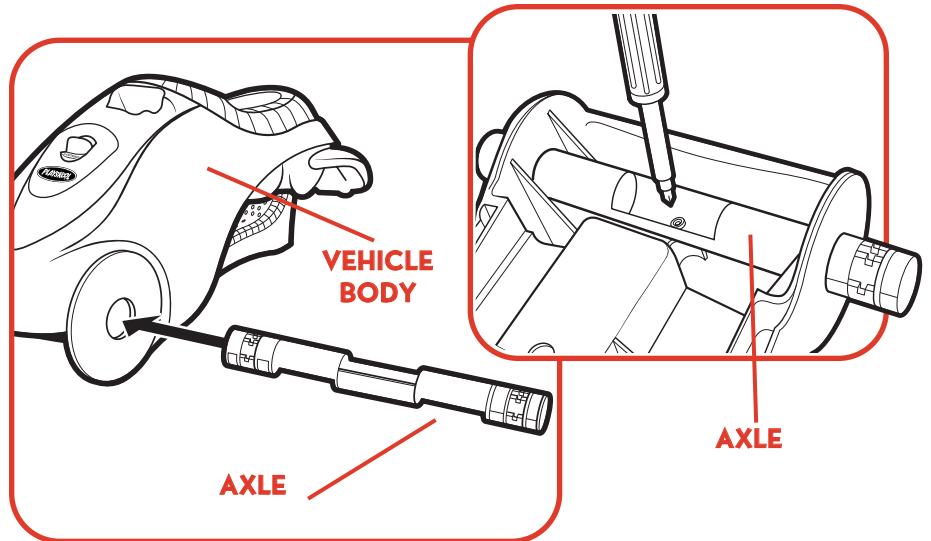
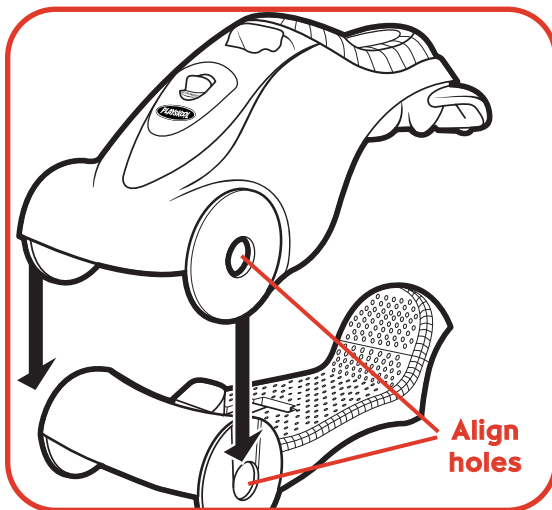

### 4. Attach Wheels to Vehicle

Note: Be sure rounded side of wheels face out when attaching to vehicle. Snap smaller wheels onto rear of base. Snap larger wheels onto axle.

ROUNDED SIDE FACING OUT

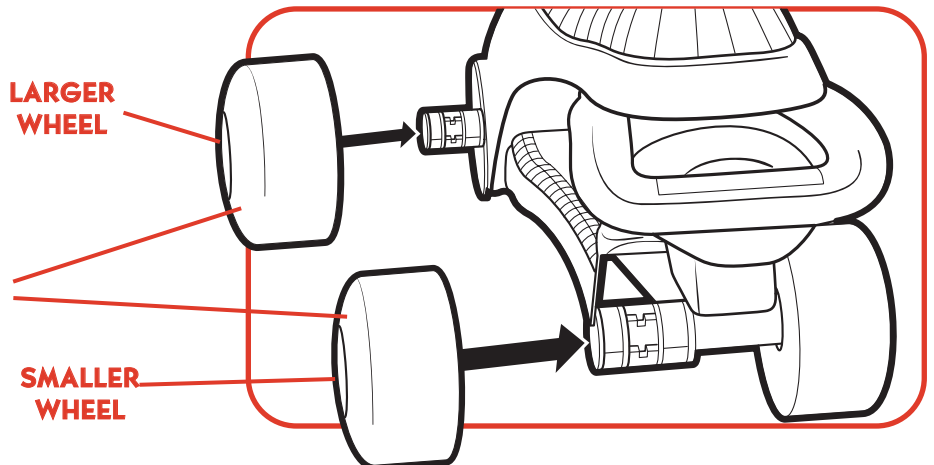

## 5. Attach Handlebar Section

Press latch on vehicle body, slide arm of handlebar section through hole in vehicle body, and snap handlebar arm into post on base. Tighten 2 screws into base post and handlebar arm.

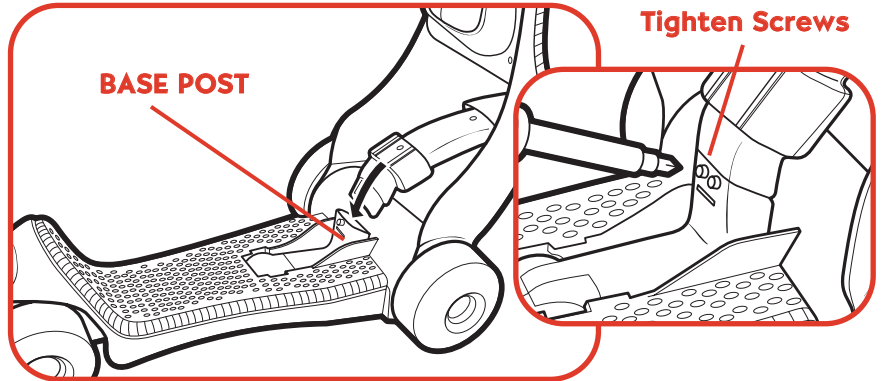
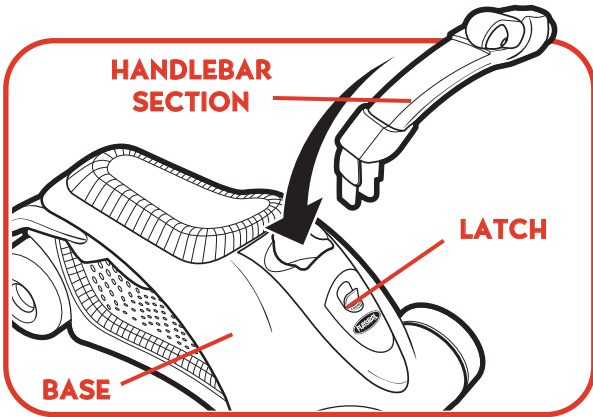

## 6. Attach Label

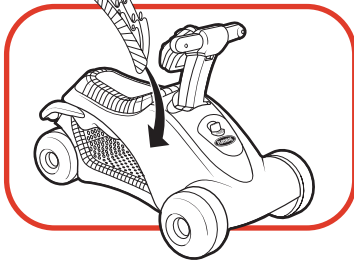

**NOW YOU'RE READY TO ROLL OR RIDE...YOU DECIDE!**

This unique toddler toy offers 2 kinds of vehicle play!  
Use it as a ride-on or scooter!

## RIDE-ON

For growing toddlers, the RIDE2ROLL Scooter is a foot-to-floor ride-on that offers extra height and leg room.

If the toy is in scooter mode:

- Push latch on vehicle body downward and bring vehicle body down until it locks into place. Be sure the word "LOCKED" appears on latch.
- Slide the clip on the dashboard unit into slot in the center of handlebar section.

**Now you're ready to ride!**

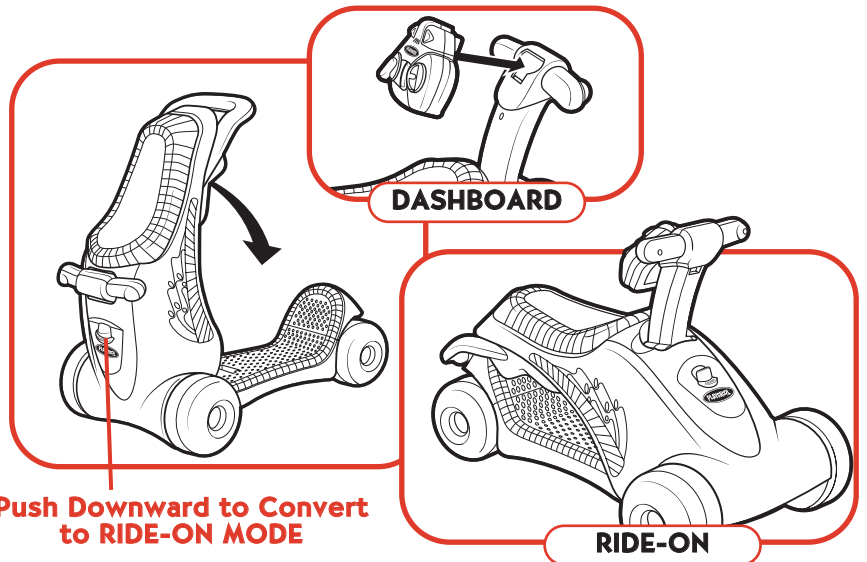

**Push Downward to Convert to RIDE-ON MODE**

## SCOOTER

As your child grows steadier on his feet, this toy easily converts to a child's first scooter that encourages balance, coordination and timing.

If the toy is in ride-on mode:

- Remove dashboard unit from handlebar section by lifting it up.
- Press latch on vehicle body and raise vehicle body until it locks into place. Be sure the word "LOCKED" appears on latch.
- Snap clip on unit to post in dashboard holder. (To remove dashboard unit, lift up on unit from bottom.)

**Now you're ready to roll!**

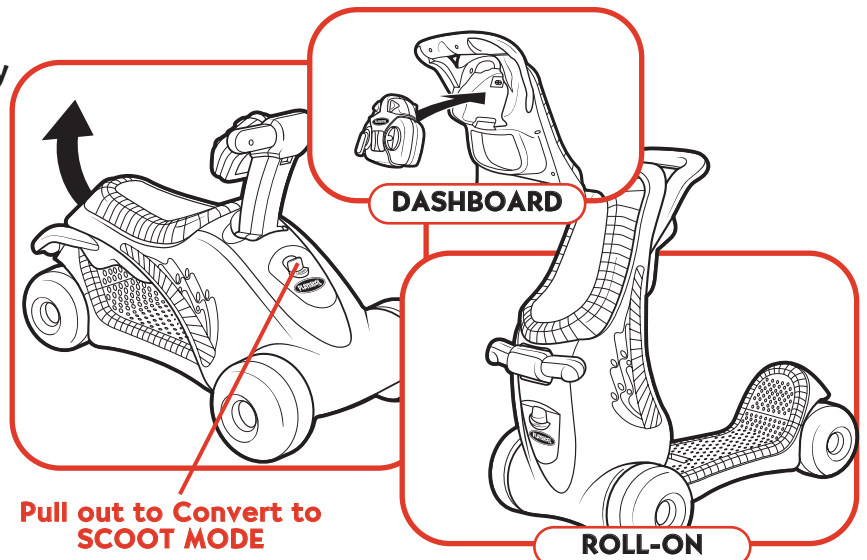

**Pull out to Convert to SCOOTER MODE**

## PLAY FEATURES

Flashing lights, happy songs, and great vehicles sounds help keep the fun in high gear - in either mode!

**Plays 5 different children's songs!**

**Perfect for indoor or outdoor fun!**

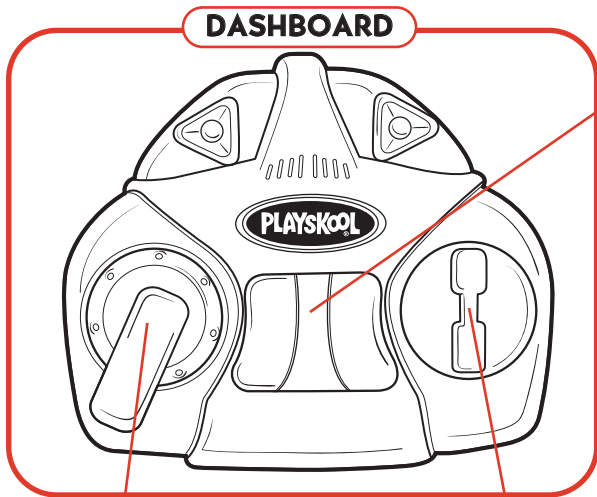

**Press button for horn sound and music!**

**Turn the "turn signal" lever for sound effects!**

**Turn the key start the engine sound!**

**Easy-grip handlebars!**

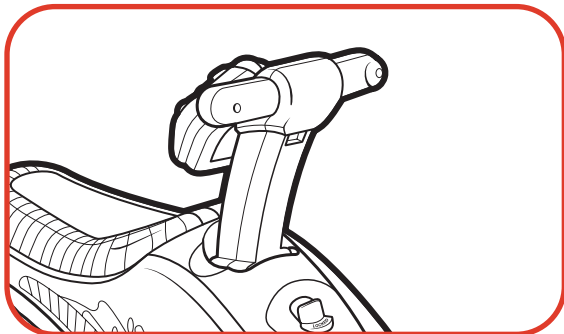

## FCC STATEMENT

This equipment has been tested and found to comply with the limits for a Class B digital device, pursuant to part 15 of the FCC Rules. These limits are designed to provide reasonable protection against harmful interference in a residential installation. This equipment generates, uses and can radiate radio frequency energy, and, if not installed and used in accordance with the instructions, may cause harmful interference to radio communications. However, there is no guarantee that interference will not occur in a particular installation. If this equipment does cause harmful interference to radio or television reception, which can be determined by turning the equipment off and on, the user is encouraged to try to correct the interference by one or more of the following measures:

- Reorient or relocate the receiving antenna.
- Increase the separation between the equipment and the receiver.
- Consult the dealer or an experienced radio/TV technician for help.



© 2003 Hasbro, Inc. All Rights Reserved.  
© denotes Reg. U.S. Pat. & TM Office.  
U.S. Patent Pending.  
06717 P/N 6293990000

**PLAYSKOOL.COM**  
FOR NEW PRODUCTS AND OFFERS  
Questions? Call: 1-800-PLAYSKL

## TO REPLACE BATTERIES

Use a Phillips/cross head screwdriver to loosen screw in battery compartment door (screw remains attached to door). Remove door. Remove and discard old batteries. Insert 3 x 1.5 V "AAA" or LR03-size batteries. Alkaline batteries recommended. Replace door and tighten screw.

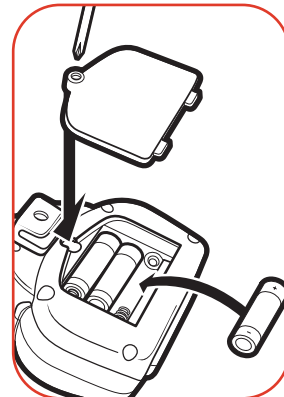

**CAUTION:**

## TO AVOID BATTERY LEAKAGE

1. As with all small batteries, the batteries used with this toy should be kept away from small children who still put things in their mouths. If they are swallowed, promptly see a doctor and, in the U.S., have the doctor phone (202) 625-3333 collect, or, in Canada, have the doctor call your provincial Poison Control Centre.
2. Make sure the batteries are inserted correctly and always follow the toy and battery manufacturers' instructions;
3. Do not mix old batteries and new batteries or alkaline, standard (carbon zinc) or rechargeable (nickel-cadmium) batteries.

## IMPORTANT: BATTERY INFORMATION

Please retain this information for future reference. Batteries should be replaced by an adult.



**CAUTION:**

1. Always follow the instructions carefully. Use only batteries specified and be sure to insert them correctly by matching the + and - polarity markings.
2. Do not mix old batteries and new batteries or standard (carbon-zinc) with alkaline batteries.
3. Remove exhausted or dead batteries from the product.
4. Remove batteries if product is not to be played with for a long time.
5. Do not short-circuit the supply terminals.
6. Should this product cause, or be affected by, local electrical interference, move it away from other electrical equipment. Reset (switching off and back on again or removing and re-inserting batteries) if necessary.
7. **RECHARGEABLE BATTERIES:** Do not mix these with any other types of battery. Always remove from the product before recharging. Recharge batteries under adult supervision. **DO NOT RECHARGE OTHER TYPES OF BATTERIES.**

## Free Manuals Download Website

<http://myh66.com>

<http://usermanuals.us>

<http://www.somanuals.com>

<http://www.4manuals.cc>

<http://www.manual-lib.com>

<http://www.404manual.com>

<http://www.luxmanual.com>

<http://aubethermostatmanual.com>

Golf course search by state

<http://golfingnear.com>

Email search by domain

<http://emailbydomain.com>

Auto manuals search

<http://auto.somanuals.com>

TV manuals search

<http://tv.somanuals.com>