

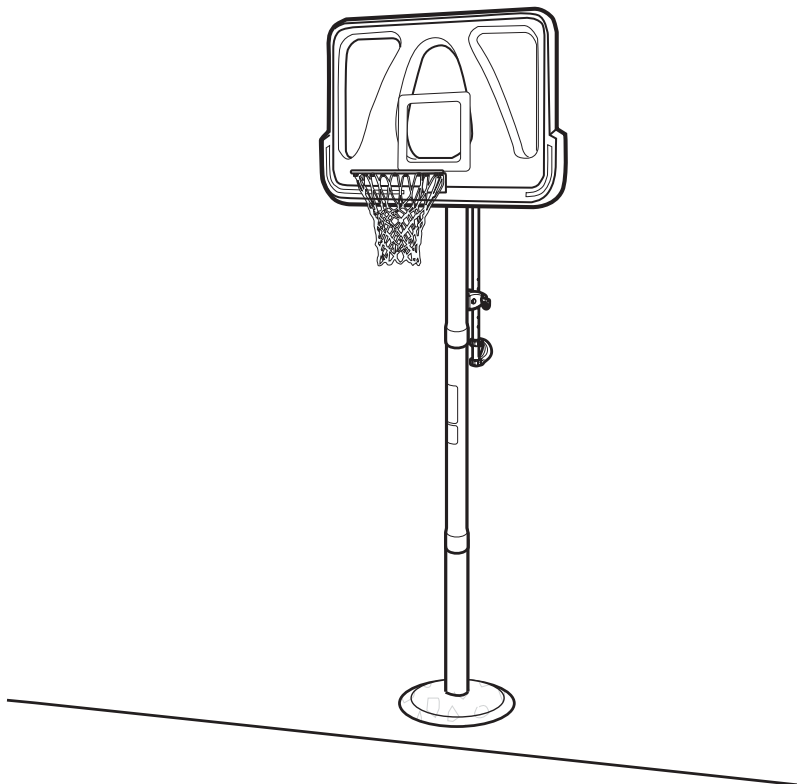

# HUFFY<sup>®</sup>SPORTS

## Inground System Owners Manual

Customer Service Center

• N53 W24700 South Corporate Circle • Sussex, WI 53089 • U.S.A.











































! WARNING!

**READ AND UNDERSTAND OPERATOR'S MANUAL BEFORE USING THIS UNIT.**

**FAILURE TO FOLLOW OPERATING INSTRUCTIONS COULD RESULT IN INJURY OR DAMAGE TO PROPERTY.**

### REQUIRED TOOLS AND MATERIALS:

<ul style="list-style-type: none"> <li> • 2 People</li> <li> • Carpenter's Level</li> <li> • 15' Tape Measure</li> <li> • Shovel &amp; Post Hole Digger</li> <li> • Wood Board (scrap)</li> <li> • Tape</li> <li> • Sawhorse or Support Table</li> <li> • Wedge</li> </ul>	<ul style="list-style-type: none"> <li> • Phillips Screwdriver</li> <li> • Hammer</li> <li> • Stepladder 8 ft. (2.4 m)</li> <li> • Safety Goggles</li> <li>• (2 each) Wrenches and/or Socket Wrenches and Sockets (Deep-Well Sockets are Recommended).</li> </ul> <table style="width: 100%; text-align: center;"> <tr> <td></td> <td></td> <td></td> <td></td> </tr> <tr> <td></td> <td></td> <td></td> <td></td> </tr> </table>									<ul style="list-style-type: none"> <li> <b>CONCRETE</b> • 540 LBS. (245 KG.)</li> <li>• Container to Mix</li> </ul> 
										
										
	<ul style="list-style-type: none"> <li>• Optional: Large &amp; Small Adjustable Wrenches</li> </ul> 									

Toll-Free Customer Service Number for U.S: 1-800-558-5234,

For Canada: 1-800-284-8339,

For Europe: 00 800 555 85234 (Sweden: 009 555 85234),

For Australia: 1-800-632 792

Internet Address: <http://www.huffysports.com>

# BEFORE YOU START!

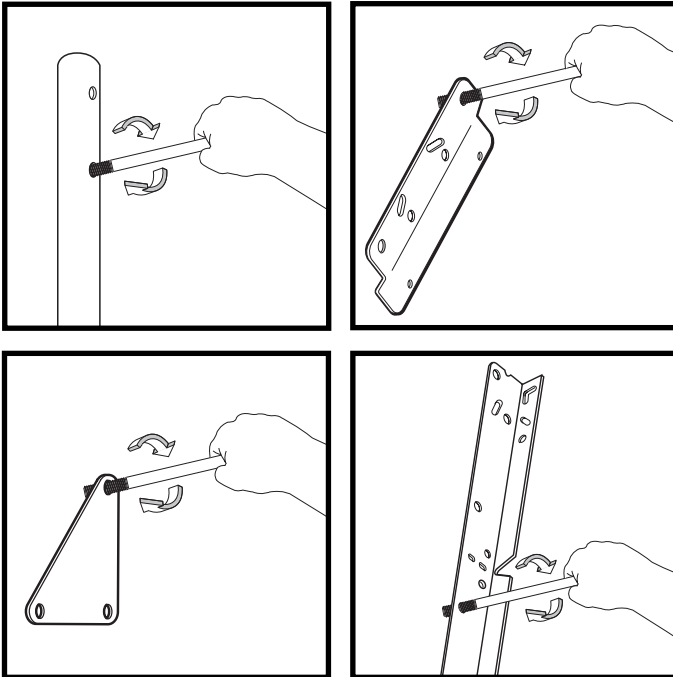

To ensure optimal playability of backboard system, a close tolerance fit between the elevator components and hardware is required. Test-fit large bolts into large holes of elevator tubes, backboard brackets, and triangle plates. Carefully rock them in a circular motion to ream out any excess paint from holes if necessary.

Not all items pictured are included with every model.

## **WARNING**

FAILURE TO FOLLOW THESE WARNINGS MAY RESULT IN SERIOUS INJURY AND/OR PROPERTY DAMAGE.

Owner must ensure that all players know and follow these rules for safe operation of the system.

- DO NOT HANG on the rim or any part of the system including backboard, support braces or net.
- During play, especially when performing dunk type activities, keep player's face away from the backboard, rim and net. Serious injury could occur if teeth/face come in contact with backboard, rim or net.
- Do not slide, climb, shake or play on pole.
- When adjusting height, keep hands and fingers away from moving parts.
- Do not allow children to move or adjust system.
- During play, do not wear jewelry (rings, watches, necklaces, etc.). Objects may entangle in net.
- Keep organic material away from pole base. Grass, litter, etc. could cause corrosion and/or deterioration.
- Check pole system for signs of corrosion (rust, pitting, chipping) and repaint with exterior enamel paint. If rust has penetrated through the steel anywhere, replace the pole immediately.
- Check system before each use for proper ballast, loose hardware, excessive wear and signs of corrosion and repair before use.
- Check system before each use for instability.
- Never play on damaged equipment.
- Keep pole top covered with cap at all times.
- See instruction manual for proper installation.

### **HUFFY**® SPORTS

In the U.S.: 1-800-558-5234 and Canada: 1-800-284-8339

201240 2/99

35

## HEIGHT ADJUSTMENT

TO ADJUST BACKBOARD:

1. While holding handle, remove pin.
2. Move elevator up or down to desired height.
3. Replace pin full length to lock system at desired height.

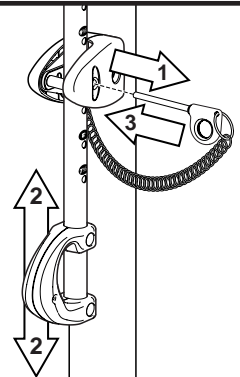

201251 2/99



# SAFETY INSTRUCTIONS



**FAILURE TO FOLLOW THESE SAFETY INSTRUCTIONS MAY RESULT IN SERIOUS INJURY, PROPERTY DAMAGE AND WILL VOID WARRANTY.**

*Owner must ensure that all players know and follow these rules for safe operation of the system.*

To ensure safety, do not attempt to assemble this system without following the instructions carefully. Proper and complete assembly, use and supervision is essential for proper operation and to reduce the risk of accident or injury. A high probability of serious injury exists if this system is not installed, maintained, and operated properly. Check entire box and inside all packing material for parts and/or additional instructional material. Before beginning assembly, read the instructions and identify parts using the hardware identifier and parts list in this document.

- If using a ladder during assembly, use extreme caution.
- Two (2) people are recommended for this operation.
- Seat the pole sections properly. Failure to do so could allow the pole sections to separate during play.
- Before digging, contact utility company to locate underground power cables, gas, and water lines. Ensure there are no overhead power lines within 20 ft. (7 m) radius of pole location.
- Climate, corrosion, excessive use, or misuse could result in system failure.
- If technical assistance is required, contact Huffy Sports.
- Minimum operational height is 6'6" (1.98 m) to the bottom of backboard.
- This equipment is intended for home recreational use only and NOT excessive competitive play.
- Read and understand the warning label affixed to pole. Label is shown below
- The life of your basketball pole depends on many conditions. The climate, placement of the pole, the location of the pole, exposure to corrosives such as pesticides, herbicides, or salts are all important.
- Adult supervision is recommended when adjusting height.
- Serious injury could occur if teeth/face come in contact with backboard, net, or rim.

*Most injuries are caused by misuse and/or not following instructions.  
Use caution when using this system.*

## PARTS LIST - See Hardware Identifier

<u>Item</u>	<u>Qty.</u>	<u>Part No.</u>	<u>Description</u>	<u>Item</u>	<u>Qty.</u>	<u>Part No.</u>	<u>Description</u>
1	1	908123	Top Pole Section	28	2	900183	Elevator Tube, Lower-Long
2	1	908125	Middle Pole Section	29	1	204837	Spring
3	1	908124	Bottom Pole Section	30	2	904807	Elevator Tube, Upper-Short
4	2	202800	Ground Sleeve	31	2	201129	Spacer, Metal .402 I.D. x .50 O.D. x 1.8
5	1	202801	Ground Sleeve Cap	32	1		Rim
6	1	204832	Bracket, Pole Mount	33	12*	201219	Smart Clip
7	2	203053	Carriage Bolt, 5/16-18 x 4 Long	34	1	204281	Net
8	9*	203100	Hex Flange Nut, 5/16-18	35	1	201251	Label, Height Adjustment
9	3*	206360	Bolt, Hex Head, 3/8-16 x 2-5/8 Long	36	1	203279	Anti-Skid Tape
10	4	203232	Washer, Metal, 3/4" O.D.	37	1	204855	Handle, Left
11	4	203063	Nut, Nylock, Hex Head, 3/8-16	38	1	204856	Handle, Right
12	2	204858	Spacer, Biscuit, Plastic	39	2	201683	Spacer, Black, 1.5 Long
13	2	204857	Spacer, Metal 1/2" O.D. x 1.44 Long	40	1	206990	Bracket Reinforcement
14	2	204859	Cover, Pin Assembly	41	1	900033	Slam Jam Bracket, Black
15	3*	203038	Carriage Bolt, 5/16-18 x 2-3/4 Long	42	1	203796	Bolt, "Tee" 3/8 - NC x 5 Long
16	1	204850	Pin, Locking	43	1	200318	Bracket Reinforcement, Slam Jam
17	1	204853	Lanyard, Black Coil	44	1	203472	Spring, Black
18	1	908152	Height Adjustment Rod	45	1	203470	Washer, Flat 5/8 I.D. x 1-1/2 O.D.
19	1	204872	Label, Height Indicator	46	1	203795	Nut, Special 3/8-NC
20	2	203103	Carriage Bolt, 5/16-18 x 2 Long	47	4	201611	Bolt, Hex-Flange 5/16-18 x 3" Long
21	1	204803	Screw, Phillips Head	48	1	240017	Bolt, Hex, 1/4-20 x 2-1/4 Long
22	4	202862	Spacer, .563 ID x 1.190 Long	49	1	240027	Nut, Hex, Nylock, 1/4-20
23	4	206311	Spacer, .53 I.D. x .65 O.D. x .5 Long	50	1	903601	Rebar
24	6	206340	Lock Nut, 1/2-13	51	2	204159	Rebar Centering Spacer
25	2	900846	Board Bracket	52	2	200533	Spacer, Board Mounting, Plastic
26	1	207103	Cap, Pole, 3.5" X .75"	53	4	205528	Bolt, Hex Flange, 5/16-18 x 1" Long
27	6	206244	Bolt, Hex Head 1/2-13 x 8 Long	54	1	206118	Label, Warning

\* YOU MAY HAVE EXTRA PARTS WITH THIS MODEL.

### NOTICE TO ASSEMBLERS

**ALL Huffy Sports Basketball Systems, including those used for DISPLAYS, MUST be assembled and ballasted with sand, water or concrete according to the instructions. Failure to follow instructions could result in SERIOUS INJURY. It is NOT acceptable to devise a makeshift weight system.**

**Questions or Missing Parts?**

**STOP!**

**DON'T go back to store!**

Call TOLL-FREE Customer Service  
Number listed on the front page!

**IMPORTANT!**  
Remove all contents from boxes.  
Be sure to check inside pole sections;  
hardware and additional parts are  
packed inside.

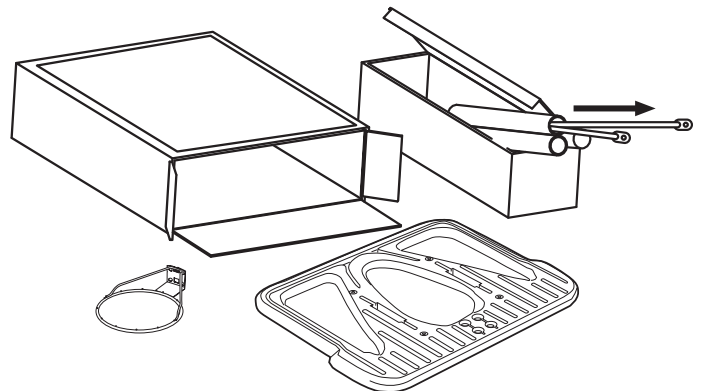

**WARRANTY CARD:**

Please remember to complete your product registration form either on-line at:  
**www.huffysports.com** or mail-in the enclosed postcard.

For more information on assembly, placement, proper use, and maintenance, visit The American Basketball Council website at <http://www.smarthoops.com>.

**HARDWARE IDENTIFIER (BOLTS & SCREWS)**

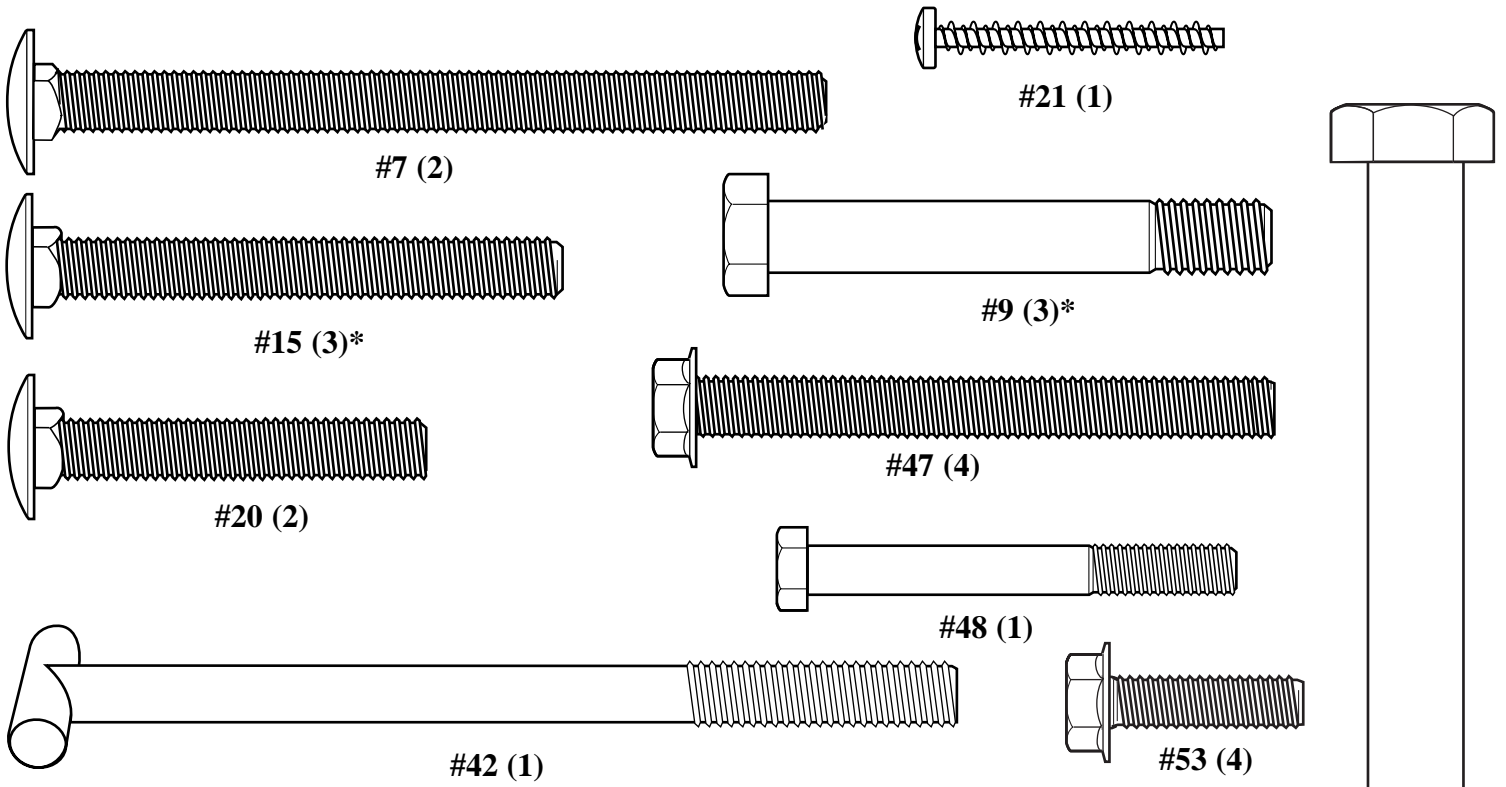

**HARDWARE IDENTIFIER (NUTS & WASHERS)**

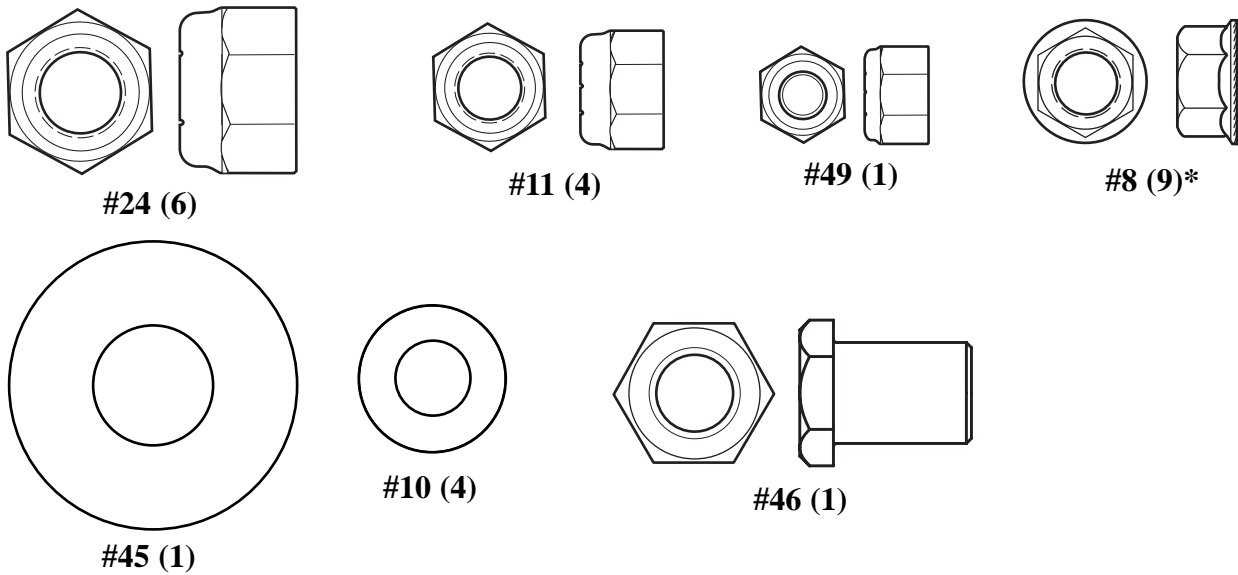

**HARDWARE IDENTIFIER (METAL SPACERS)**

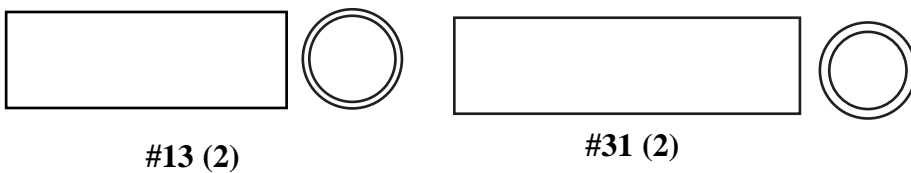

\* You may have extra parts with this model.

#27 (6)

**HARDWARE IDENTIFIER (PLASTIC SPACERS & CLIPS)**

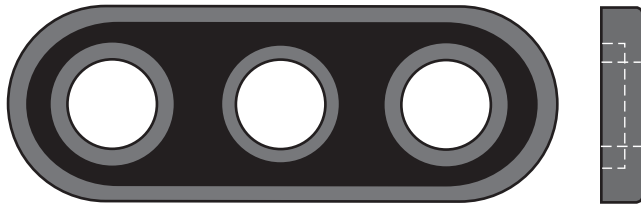

**#12 (2)**

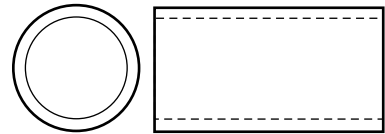

**#22 (4)**

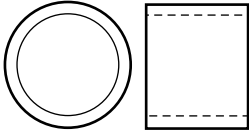

**#23 (4)**



**#39 (2)**



**#33 (12)\***

**HARDWARE IDENTIFIER (OTHER)**

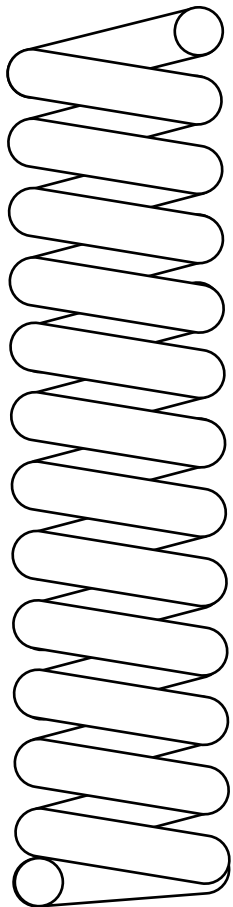

**#44 (1)**

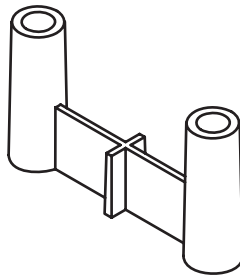

**#52 (2)**

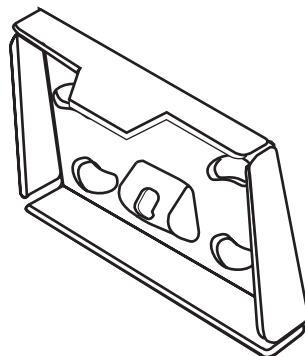

**#41 (1)**

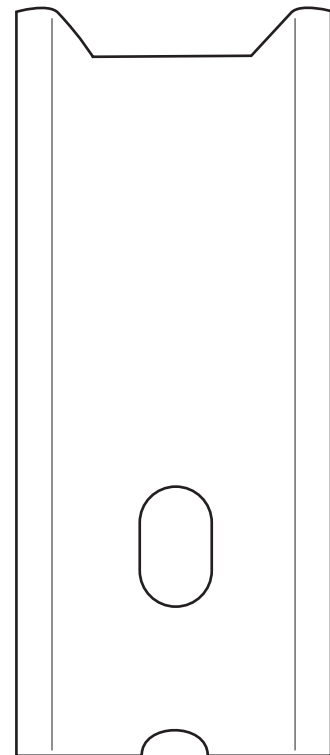

**#43 (1)**

# SECTION A: ASSEMBLE THE POLE

This is what your system will look like when you've finished this section:

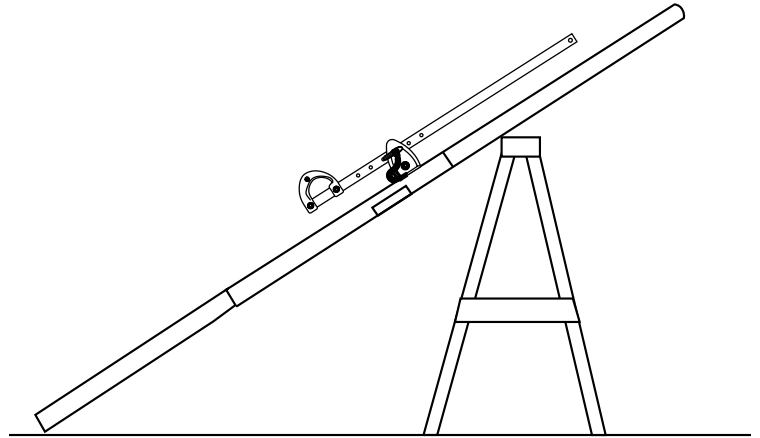

## TOOLS REQUIRED FOR THIS SECTION

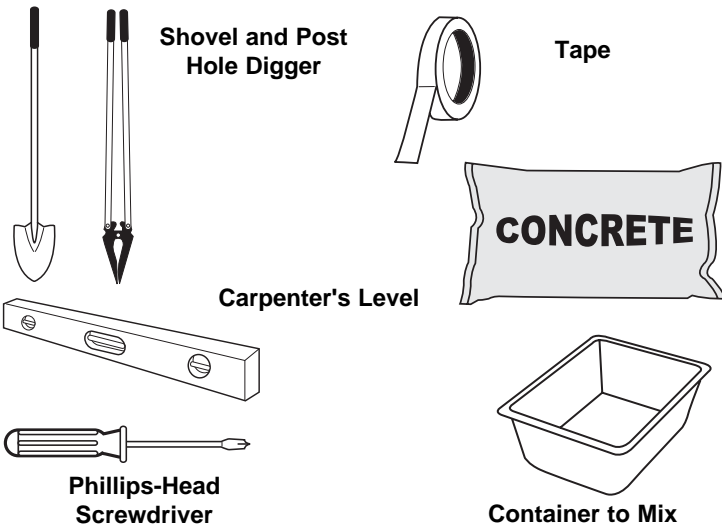

(2) 1/2" and (2) 9/16" Wrenches

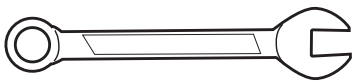

AND/OR

(2) Socket Wrenches and Sockets

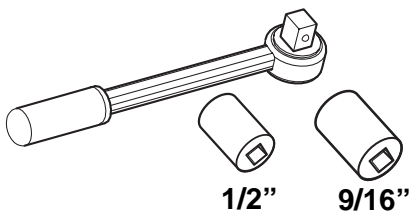

## HARDWARE USED IN THIS SECTION (not actual size)

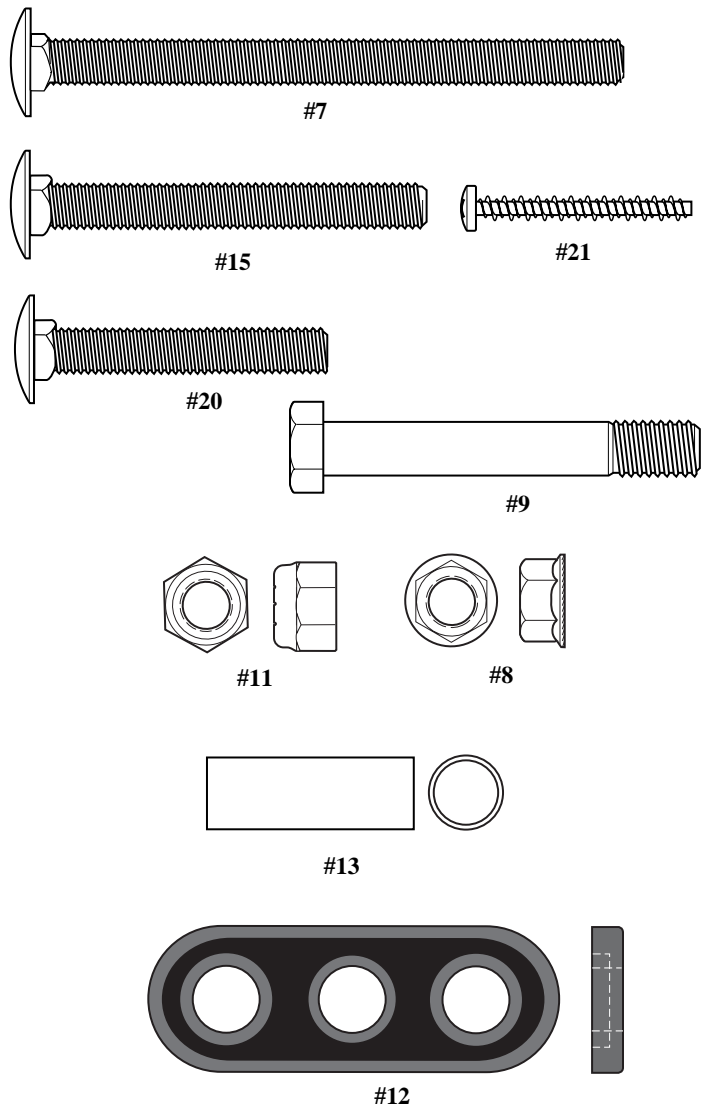

1. Mark pole sections with tape (not supplied) at indicated distances from ends as shown.

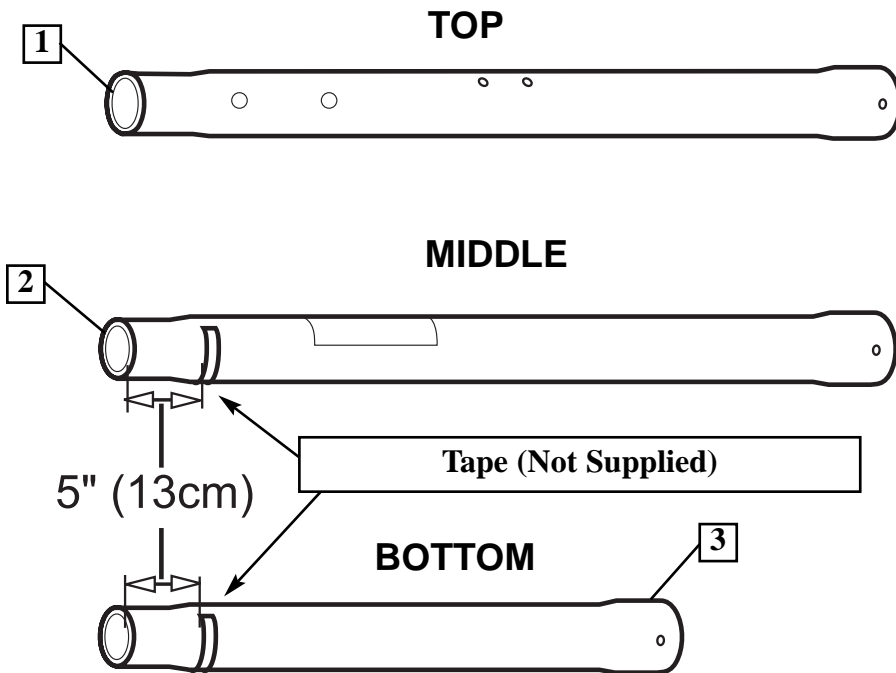

2. Ensure ground is level with playing surface, then dig pole hole.

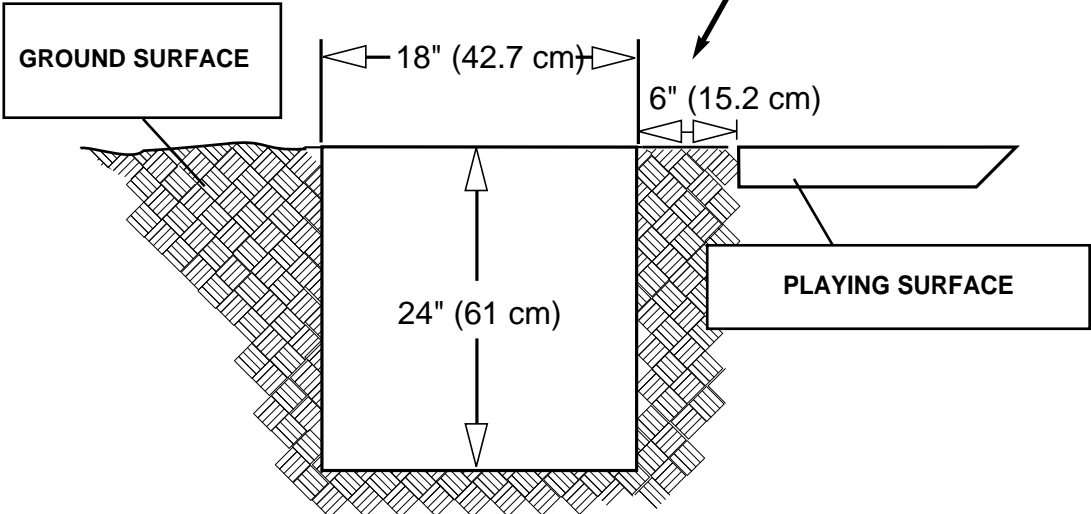
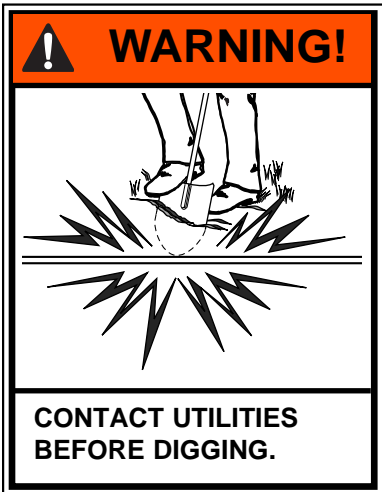



3.

Snap two halves of ground sleeve (4) together.

Insert and secure bottom pole section (3) into ground sleeve (4) by tightening ground sleeve cap (5).

**NOTE:** Flared end goes inside ground sleeve.

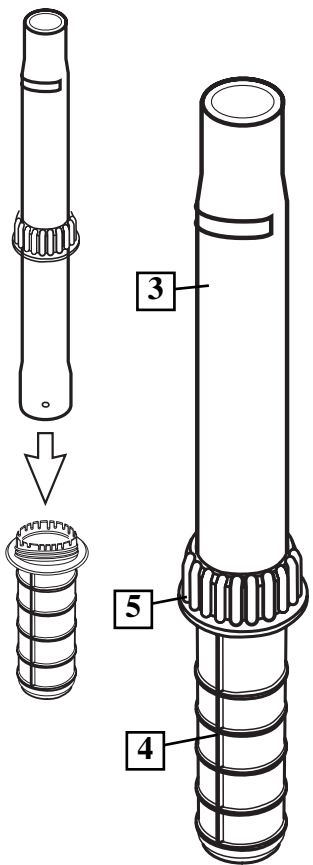
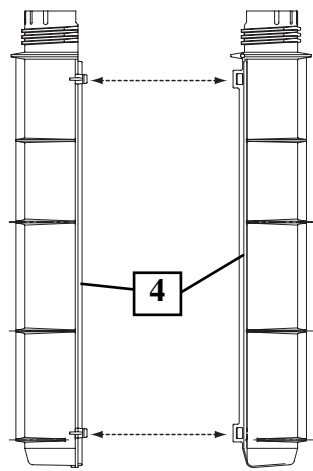

4.

Fill hole approximately 1/3 full with mixed concrete.

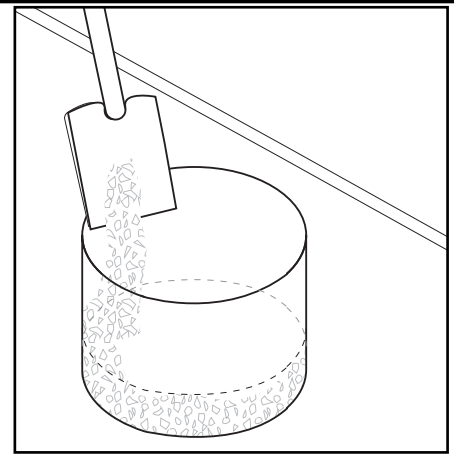

5.

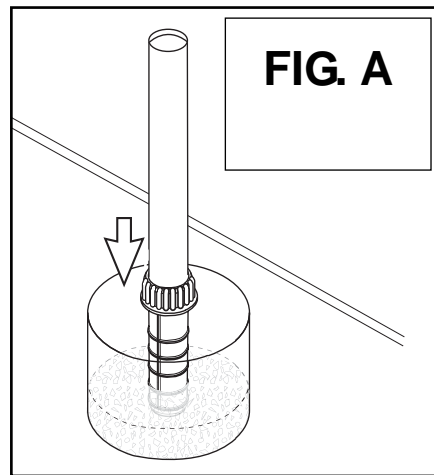

Insert ground sleeve assembly and center in hole (FIG. A).

**Note:** Leave 1" below flange exposed for drainage hill.

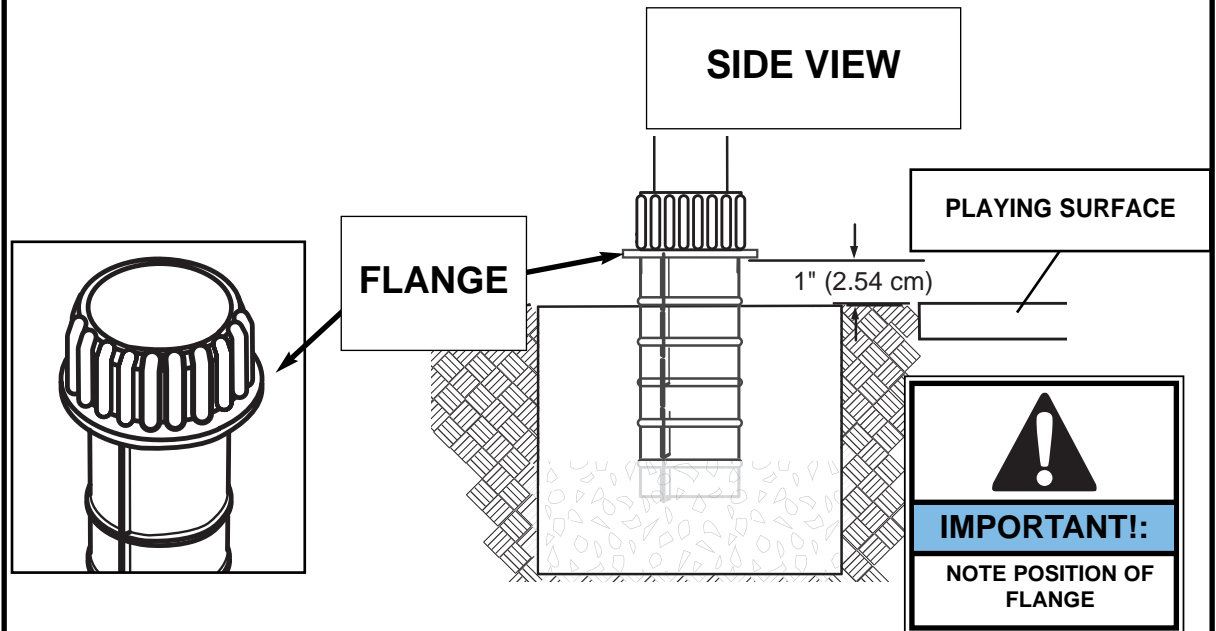

**IMPORTANT!: CONTINUE ON TO NEXT STEP. DO NOT WAIT FOR CONCRETE TO CURE.**

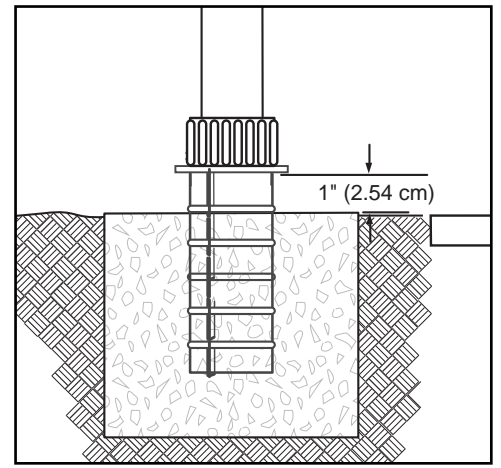
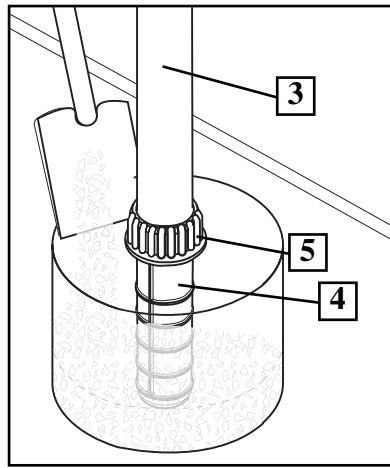

**6.** Fill hole completely with concrete.

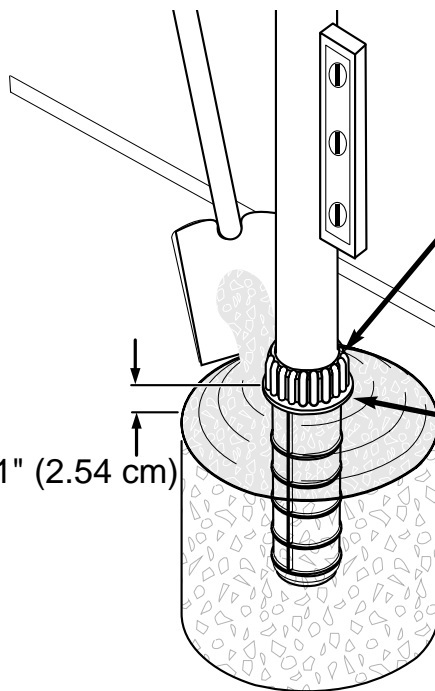

**IMPORTANT!: CONTINUE ON TO NEXT STEP.  
DO NOT WAIT FOR CONCRETE TO CURE.**

**7.** Tamp down concrete to release air pockets and build drainage hill. Level pole section in all directions several times while concrete is curing.

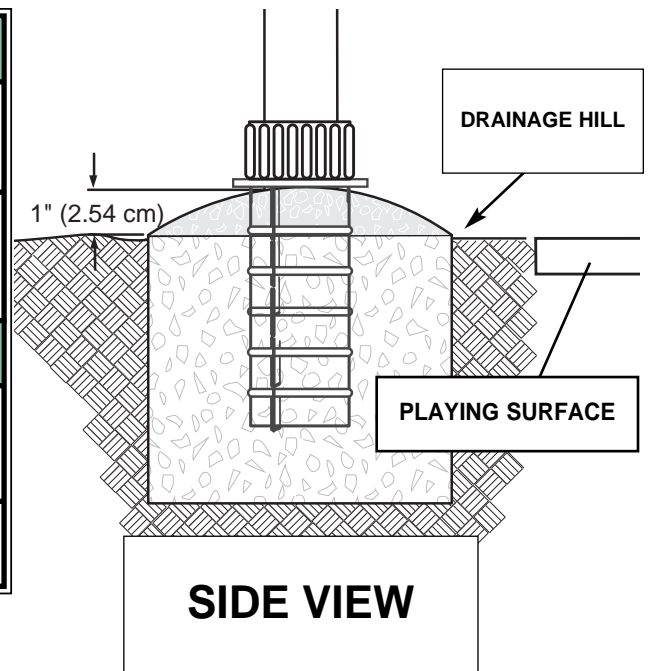

<b>NOTE A:</b>

Make a reference mark here for anti-skid tape.
<b>NOTE B:</b>

Keep flange pushed down to concrete and leveled.

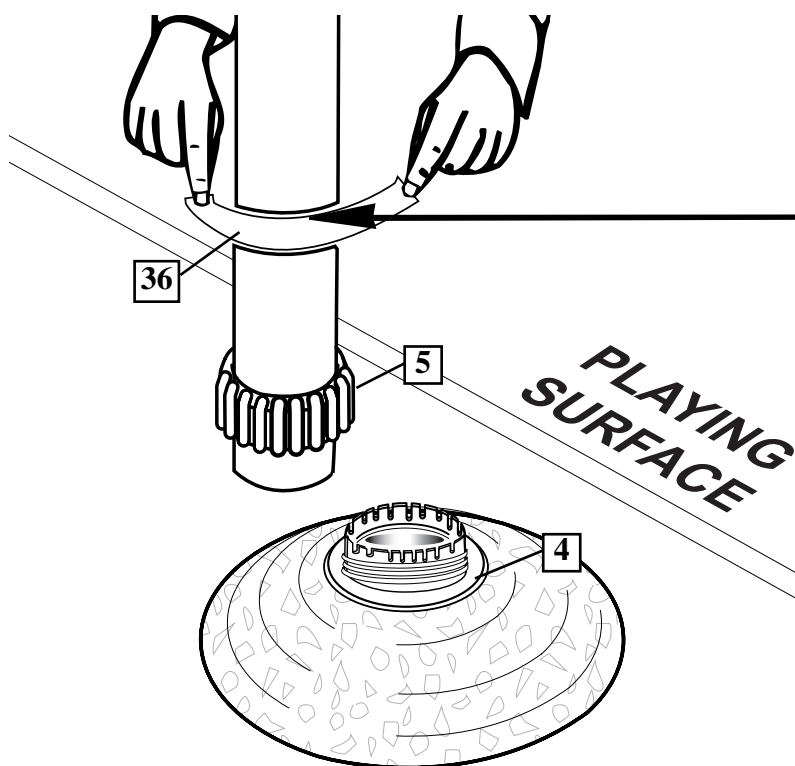

**IMPORTANT!: WAIT A MINIMUM OF 24 HOURS BEFORE  
GOING ON TO NEXT STEP. CONCRETE MUST CURE.**

- 8.** After concrete has cured, remove bottom pole section from ground sleeve (4). Place anti-skid tape (36) around the bottom area of bottom pole (see note A). **KEEP GROUND SLEEVE CAP ON BOTTOM POLE.**



**NOTE A:**

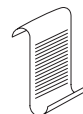

Place top edge of anti-skid tape on mark made in step 7.

**NOTE B:**

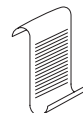

Tape prevents the pole from rotating during play.

**9.** Stack and bounce bottom (3) and middle (2) pole sections together. Bounce pole sections together until middle section no longer moves toward taped reference mark on bottom pole.

**10.** Stack upper pole section (1) to bottom and middle pole assembly and continue bouncing until top pole (1) no longer moves toward taped reference mark on middle pole.

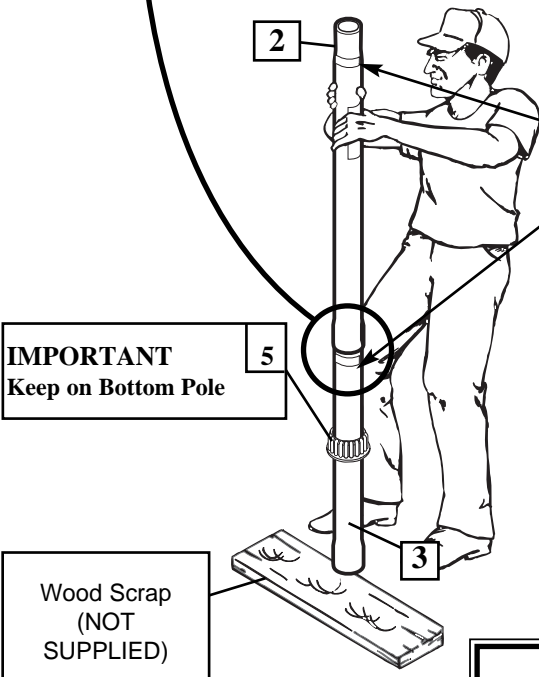
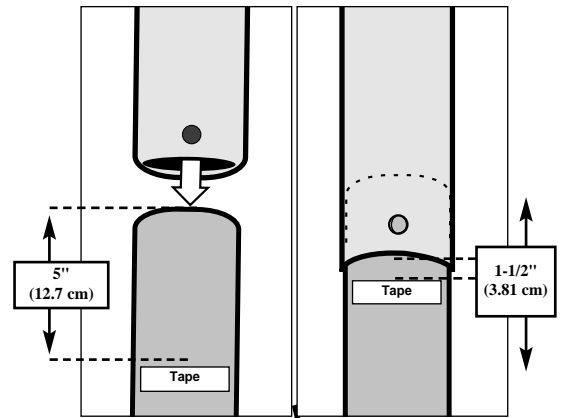
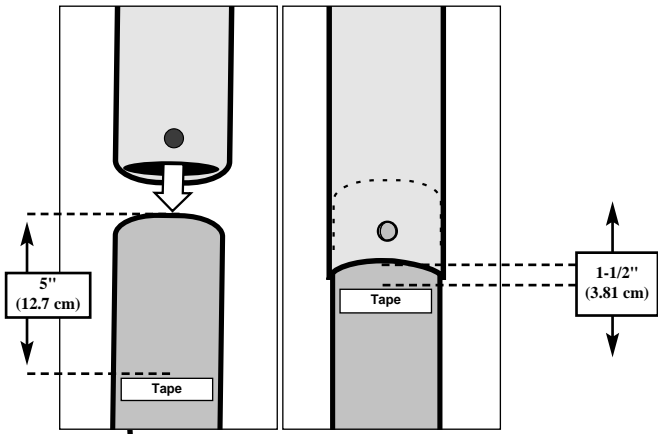

Taped reference marks

Wood Scrap (NOT SUPPLIED)

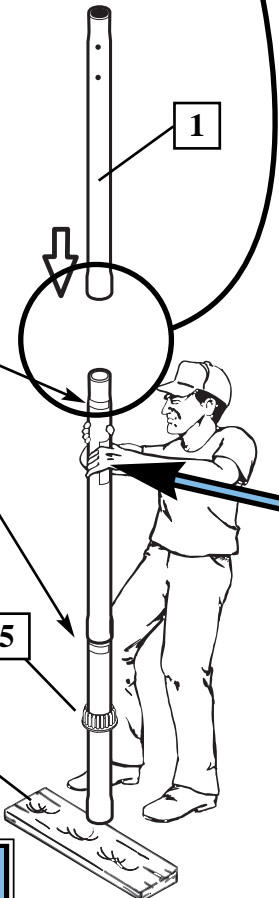

**! IMPORTANT!**  
The warning label should be 90 degrees from uppermost holes on top pole (1) - see Illustration.

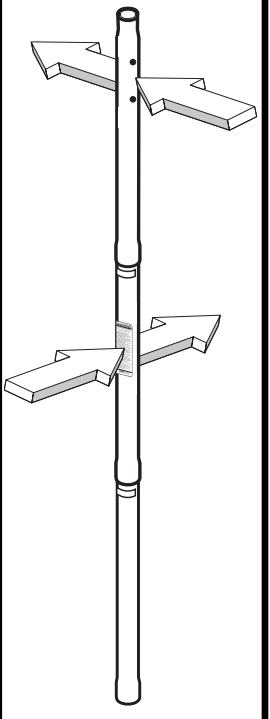

**! IMPORTANT!**  
POLE SECTIONS SHOULD HAVE A 3-1/2" (9 CM) MINIMUM OVERLAP.

- 11.** Install pole mount bracket (6) and bracket reinforcement (40) with carriage bolts (7) as shown. Tighten flange nuts (8) completely.

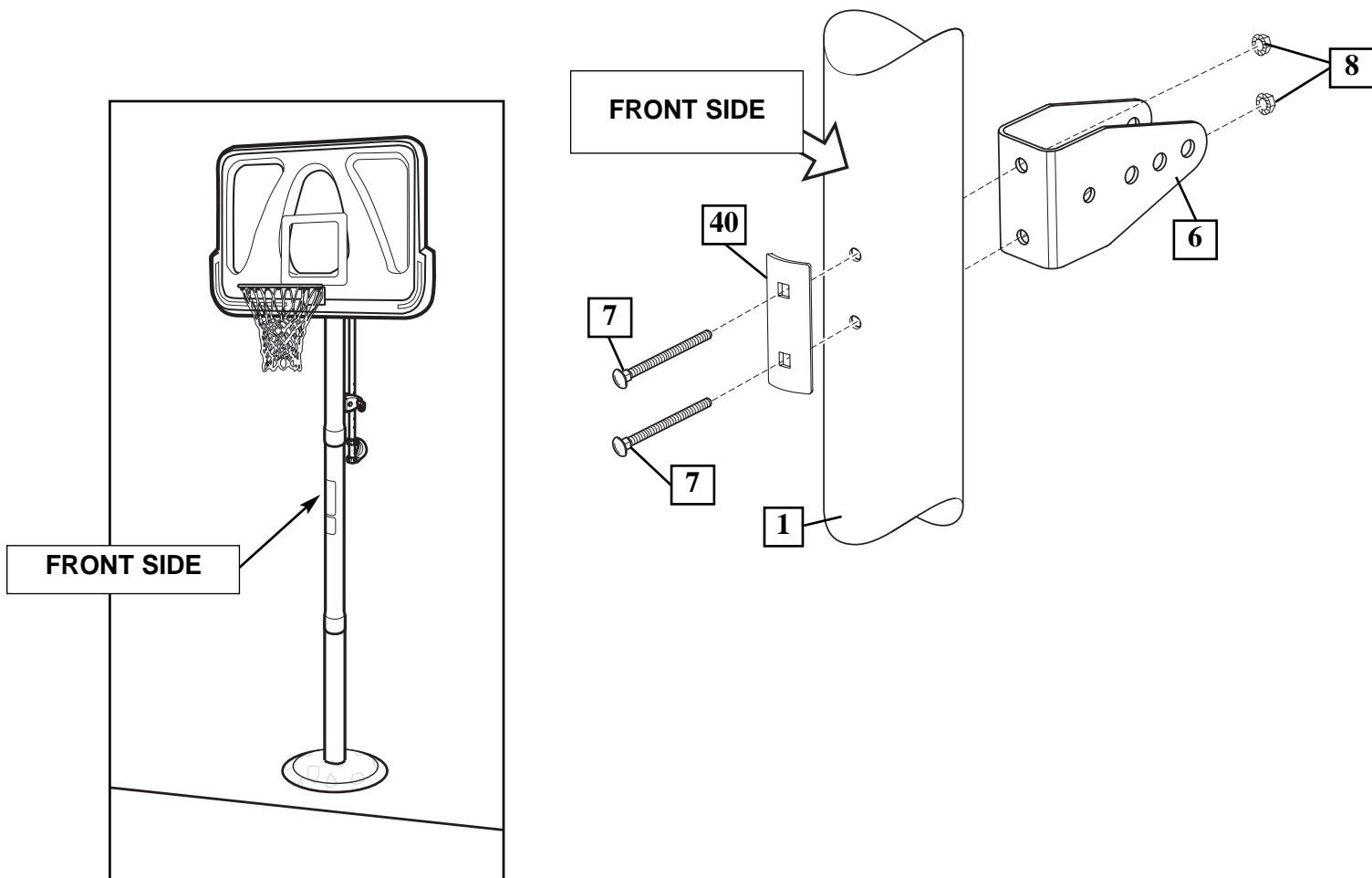

- 12.** Attach spacers (12, 13) to pole mount bracket (6) with bolts (9), washers (10), and nuts (11) as shown.

**! IMPORTANT!:**  
Tighten just until washers (10) stop moving.

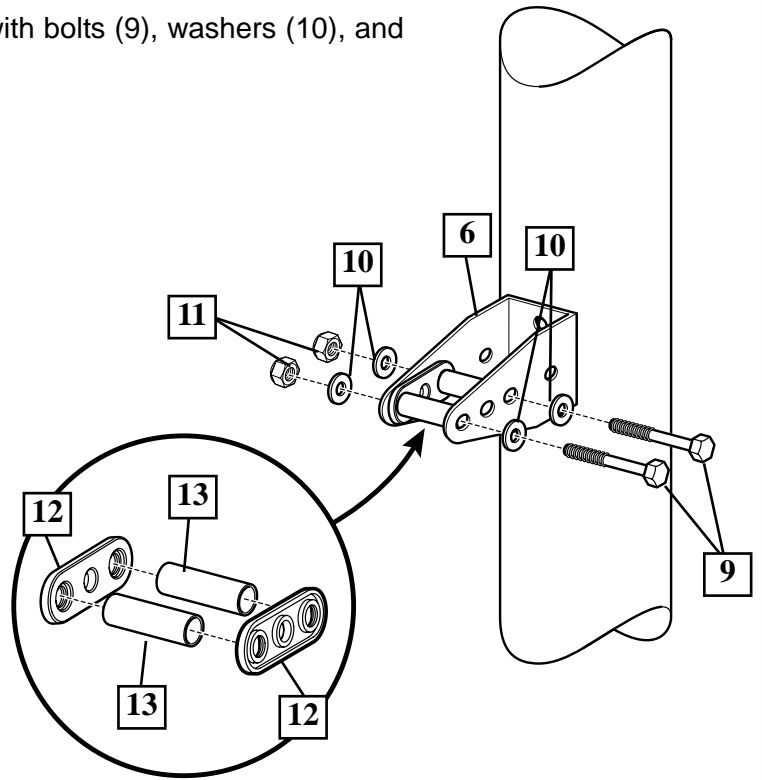

- 13.** Assemble lanyard (17) to locking pin (16) as shown. Attach covers (14) onto pole mount bracket (6) with carriage bolt (15) and nut (8) as shown. **DO NOT OVERTIGHTEN**

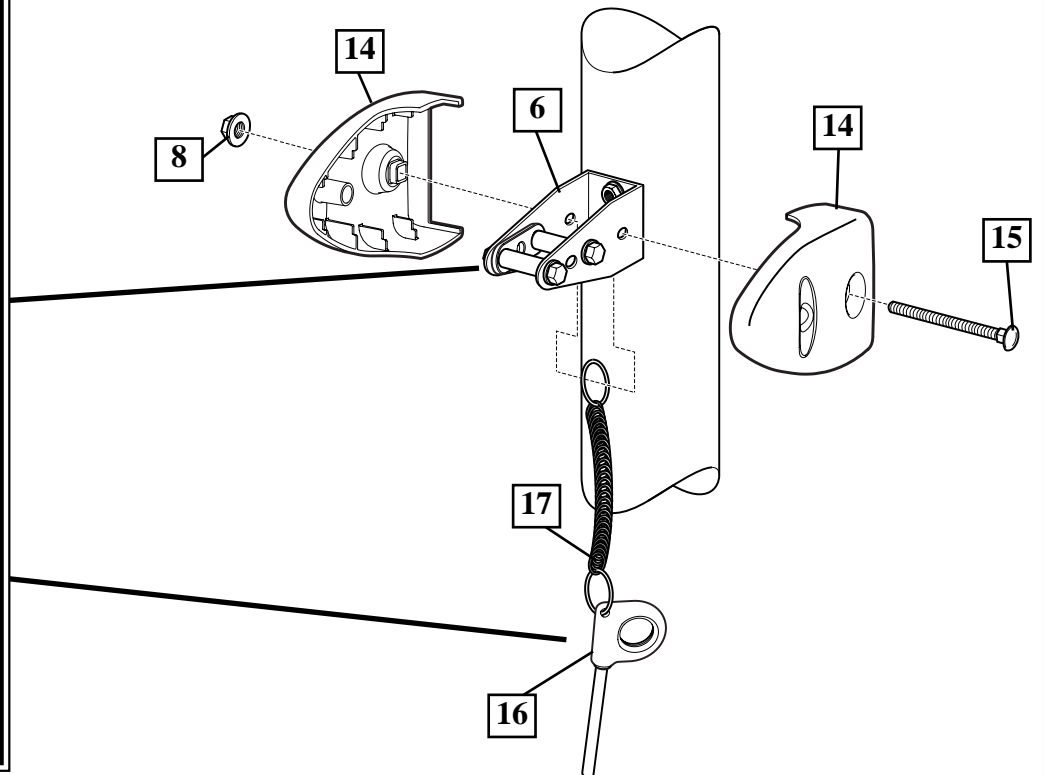
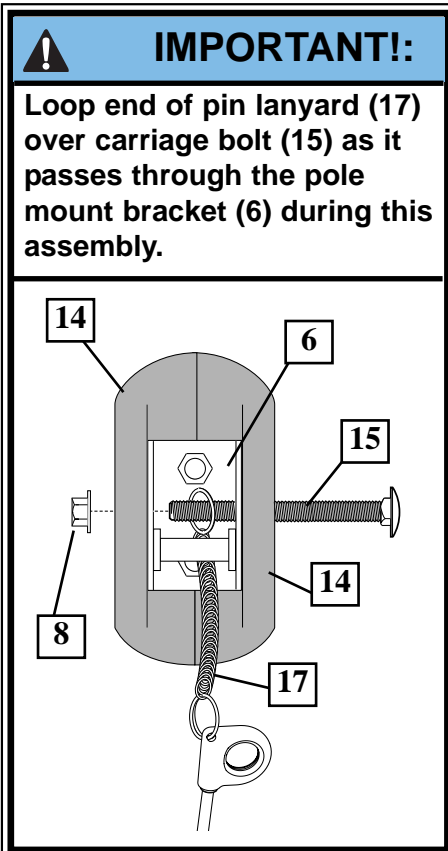

14.

Apply logo and height indicator labels (19) to adjustment rod (18) as shown. Attach handle parts (37, 38) to adjustment rod with screw (21), carriage bolt (20), and flange nut (8) as shown.

**NOTE:** Holes in adjustment rod allow for either rear access or side access.

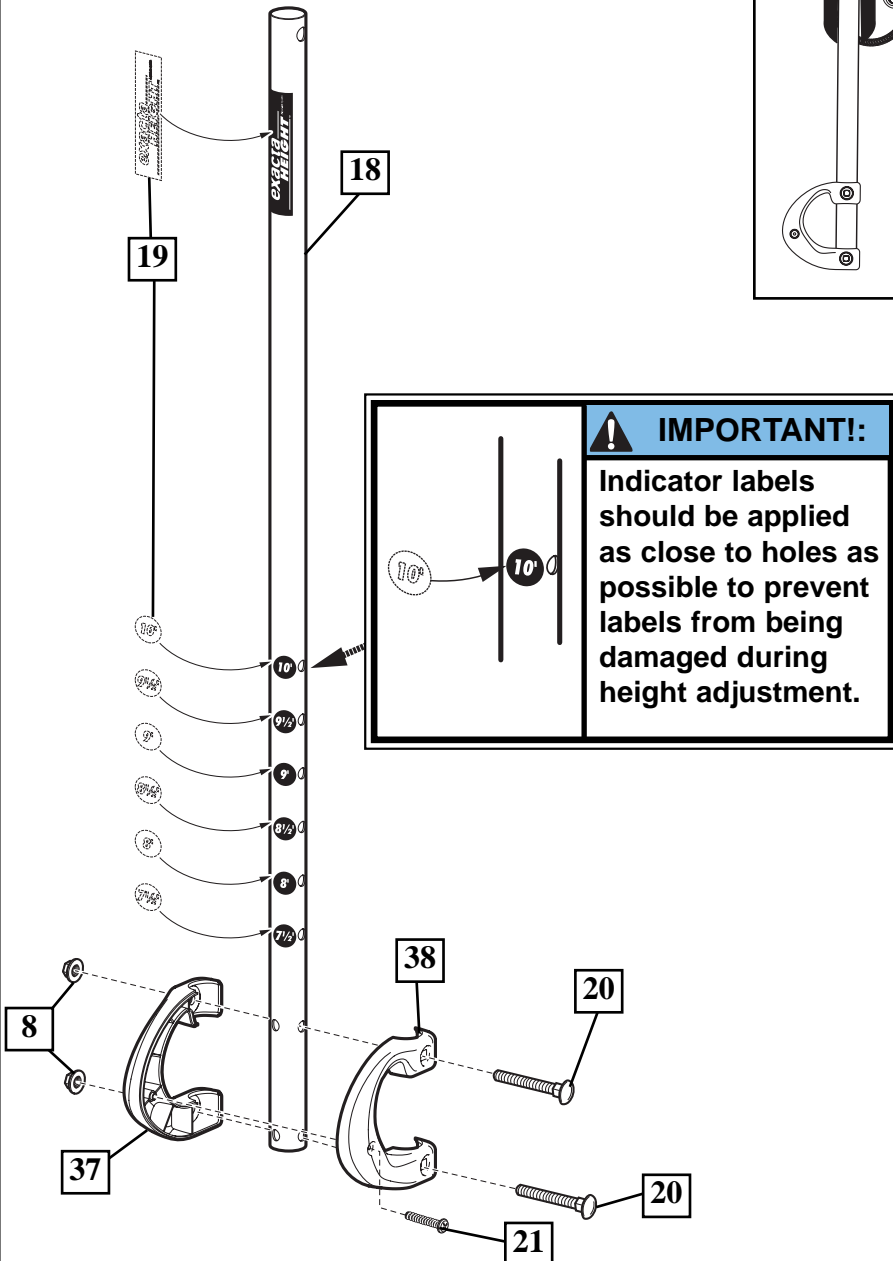

**SIDE ACCESS**

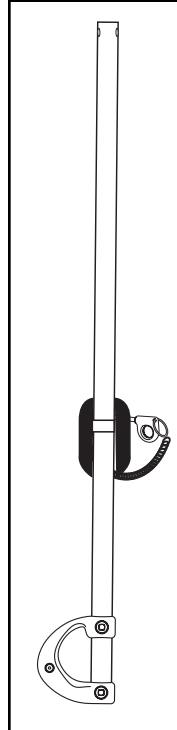

15.

Insert handle assembly through pole mount assembly as shown.

Lock pole assembly in place at the 10' (3.05 m) mark with pin (16).

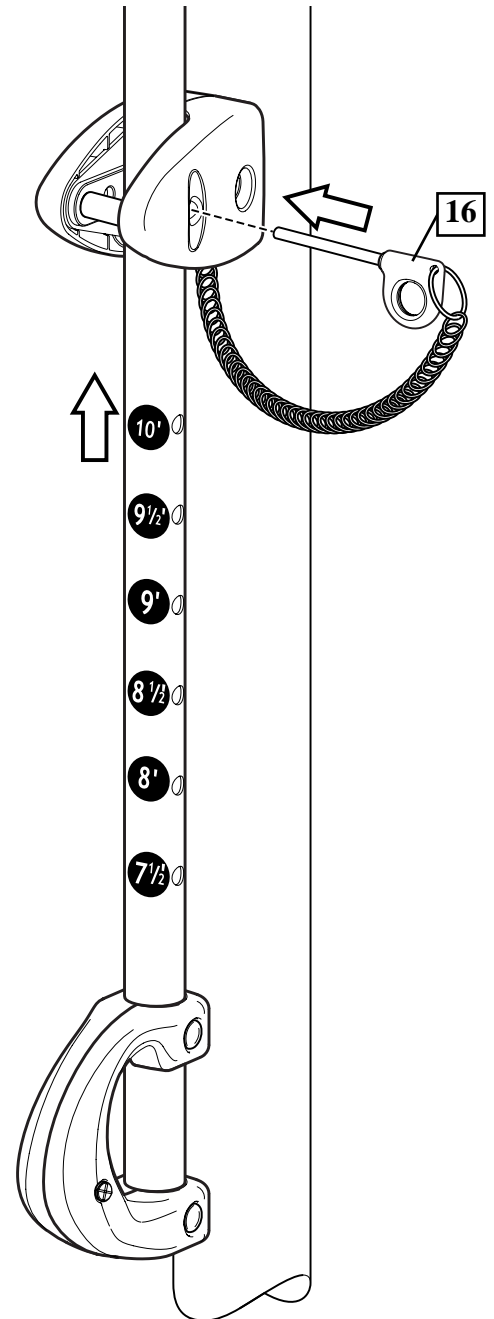

# SECTION B: ASSEMBLE THE ELEVATOR TUBES TO BACKBOARD

This is what your system will look like when you've finished this section:

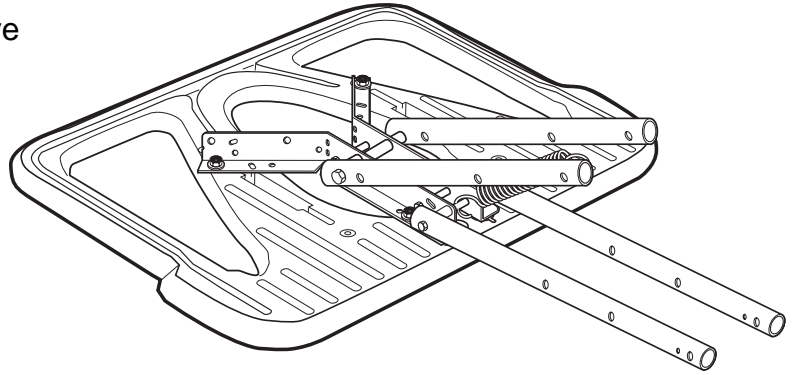

## TOOLS REQUIRED FOR THIS SECTION



(2) Wrenches 1/2", (2), 9/16" and (2) 3/4"

AND/OR

(2) Socket Wrenches and Sockets

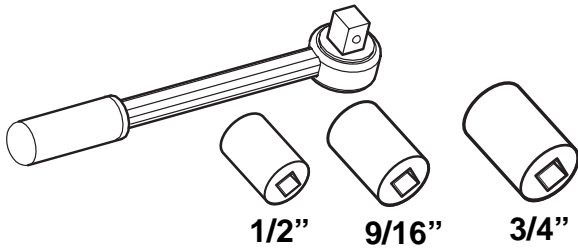

## HARDWARE USED IN THIS SECTION (not actual size)

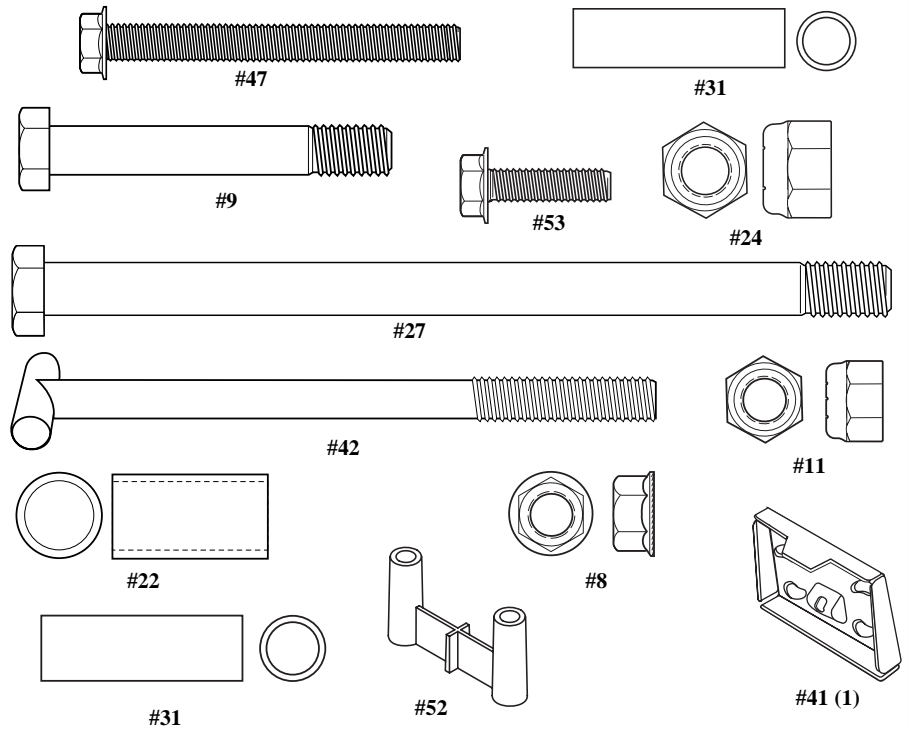

Identify elevator tubes (28 & 30).

Toward Board



Upper Elevator tube

30

Toward Pole

Toward Board



Lower Elevator tube

28

Toward Pole



- 1.** Assemble backboard support brackets (25) using bolts (9 & 48), spacers (31), and nuts (11 & 49) as shown.

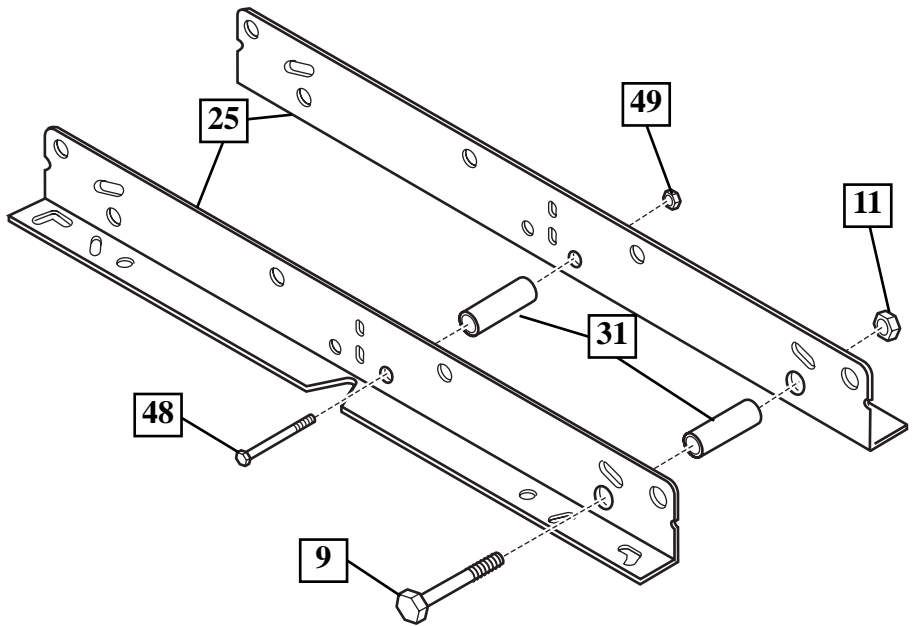

- 2.** Attach lower elevator tubes (28) and counter balance spring (29) to backboard support brackets (25) using spacers (22), bolt (27), and nut (24) as shown.

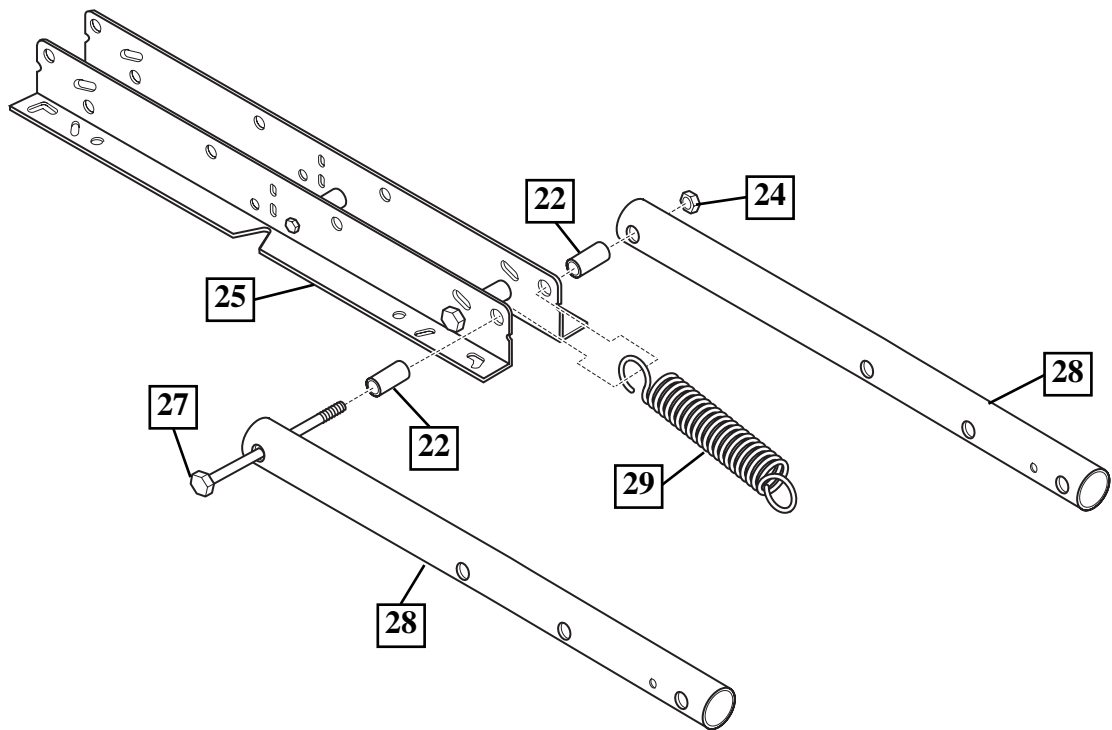

- 3.** Place board spacers (52) into board as shown. Bend upper portion of the board brackets (25) to match holes in backboard as shown. Insert t-bolt (42) into rim bracket (41). Secure board brackets (25) and rim bracket (41) to backboard with bolts (53 & 47) and nuts (8). Insert bolts (53) into unused holes in board

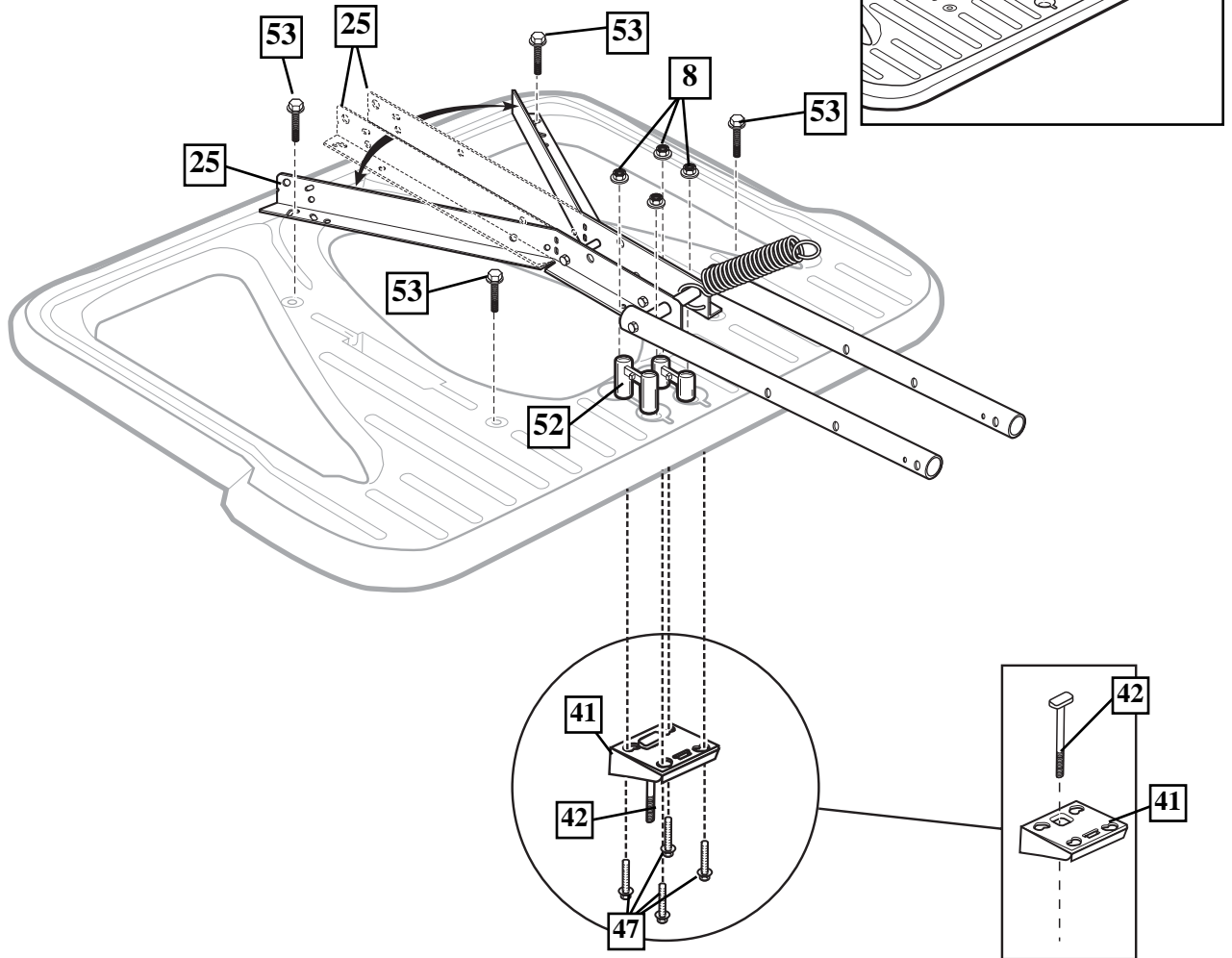

- 4.** Attach upper elevator tubes (30) to backboard support brackets (25) using spacers (22), bolt (27), and nut (24) as shown.

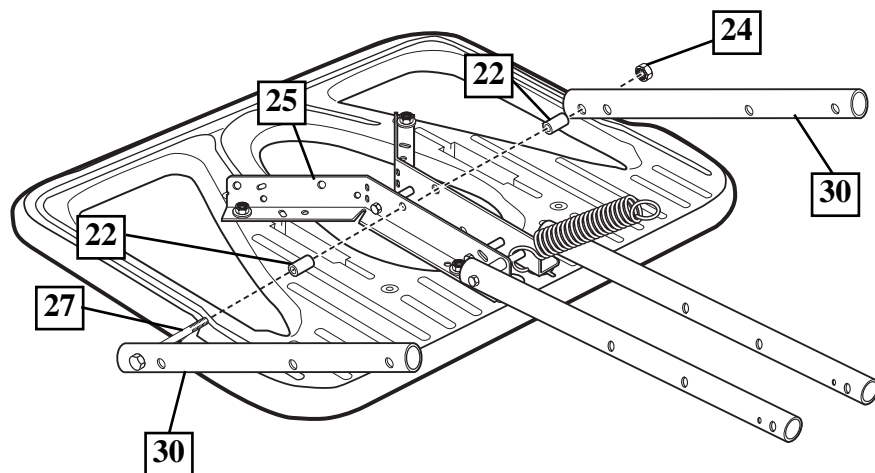

# SECTION C: ATTACH THE BACKBOARD & ELEVATOR ASSEMBLY TO POLE SYSTEM

This is what your system will look like when you've finished this section:

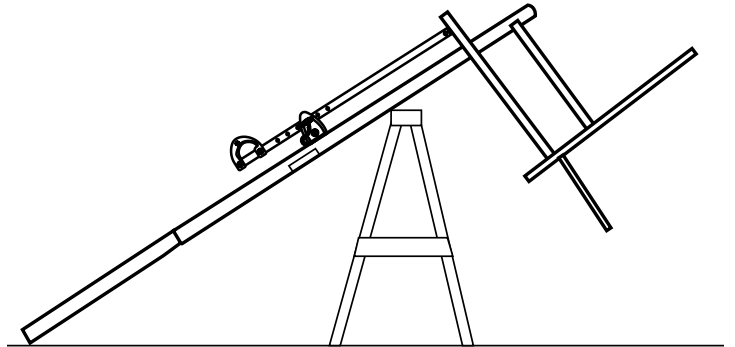

## TOOLS REQUIRED FOR THIS SECTION

## HARDWARE USED IN THIS SECTION (not actual size)

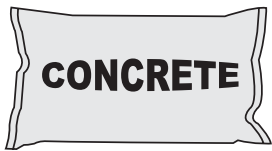

**CONCRETE**

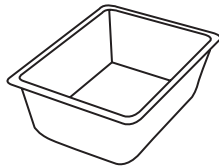

Container to Mix



Phillips-Head  
Screwdriver

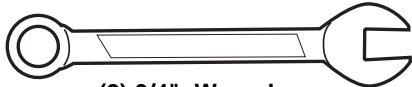

(2) 3/4" Wrenches

AND/OR

(2) Socket Wrenches and Sockets

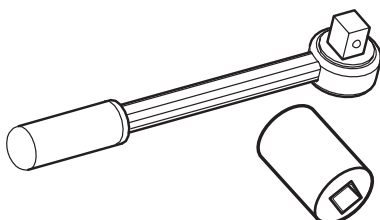

3/4"

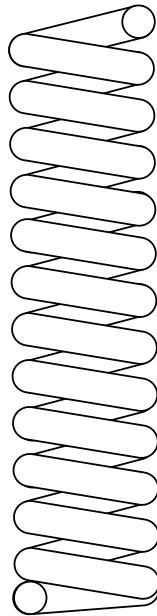

#44

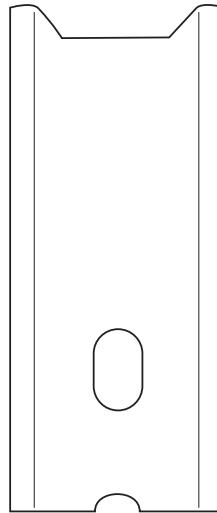

#43

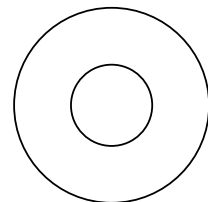

#45

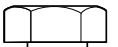

#27

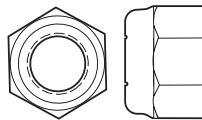

#24



#46

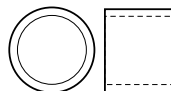

#23

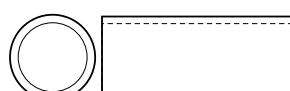

#39



#33

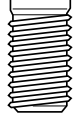

**1.** Support pole on sawhorse. Attach backboard assembly to top pole section (1).

**WARNING!** 

USE CAUTION; ELEVATOR ASSEMBLY IS HEAVY.

TWO PEOPLE REQUIRED FOR THIS PROCEDURE. FAILURE TO FOLLOW THIS WARNING COULD RESULT IN SERIOUS INJURY AND/OR PROPERTY DAMAGE.

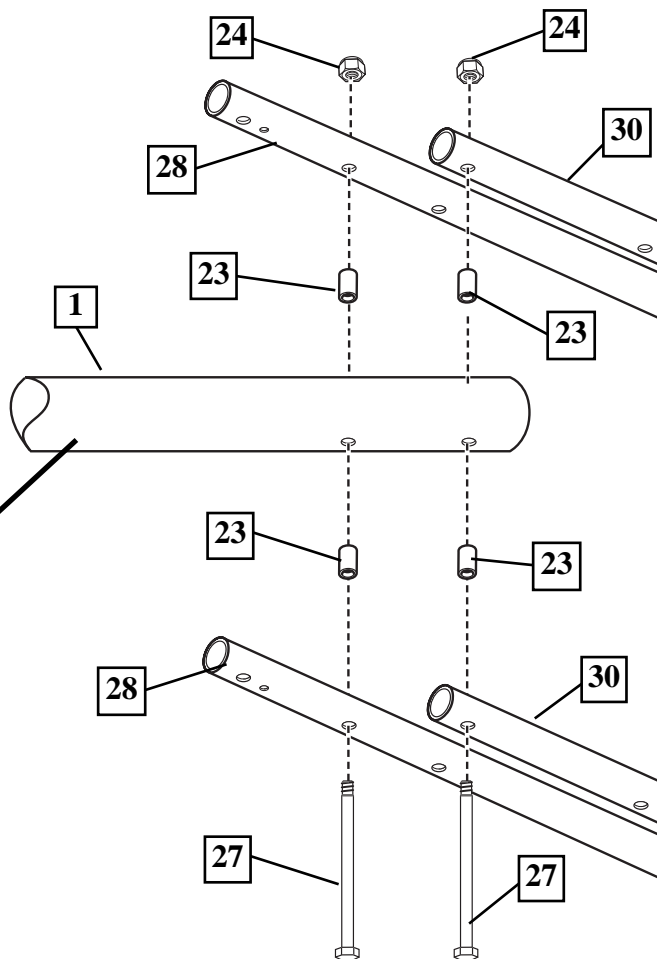
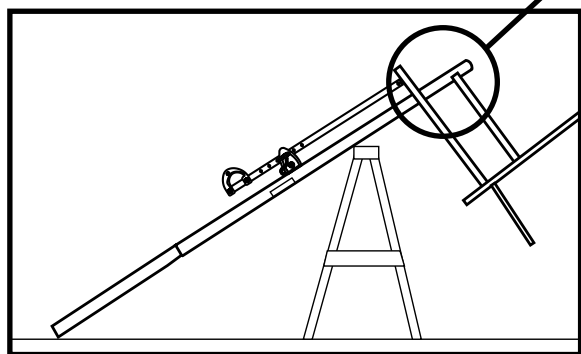

**2.**

Install handle assembly to long elevator tubes (28) using bolt (27), spacers (39), and nut (24) as shown.

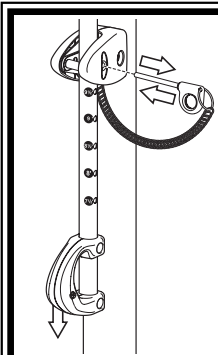
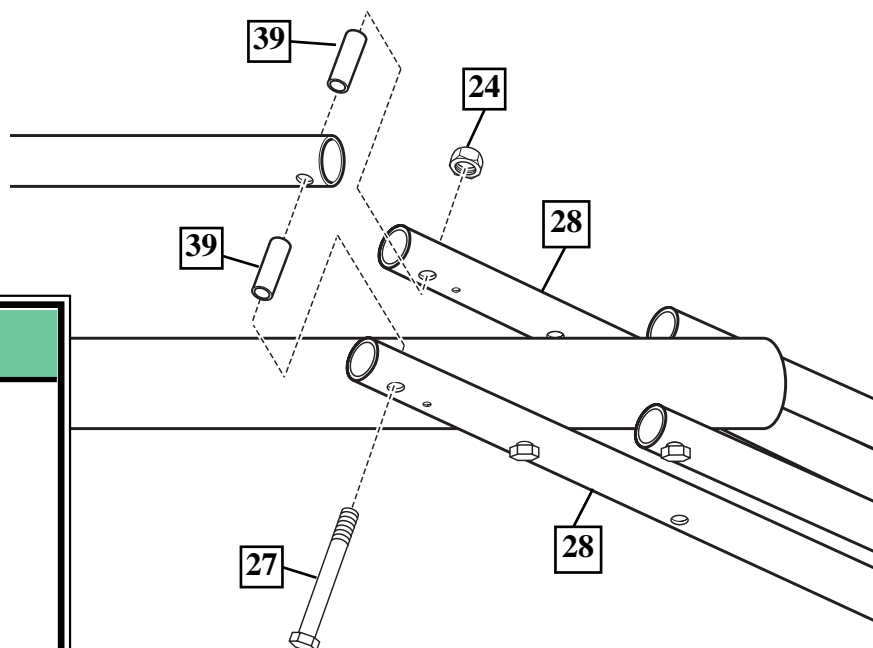

**NOTE:**

Before going on to next step, set adjustable system assembly to the 10' (3.05 m) setting.

**3.****Install Slam Jam Rim to Backboard**

- A • Fit rim (32) securely into bracket (41) as shown (Allow "T"-bolt (42) to slip through center hole in rim (32)).
- B • Install reinforcement bracket (43) onto "T" bolt (42) as shown.
- C • Install spring (44) onto "T" bolt (42) as shown.
- D • Install special nut (46) and washer (45) onto "T" bolt (42).
- E • Tighten nut (46) until flush with end of "T" bolt (42).

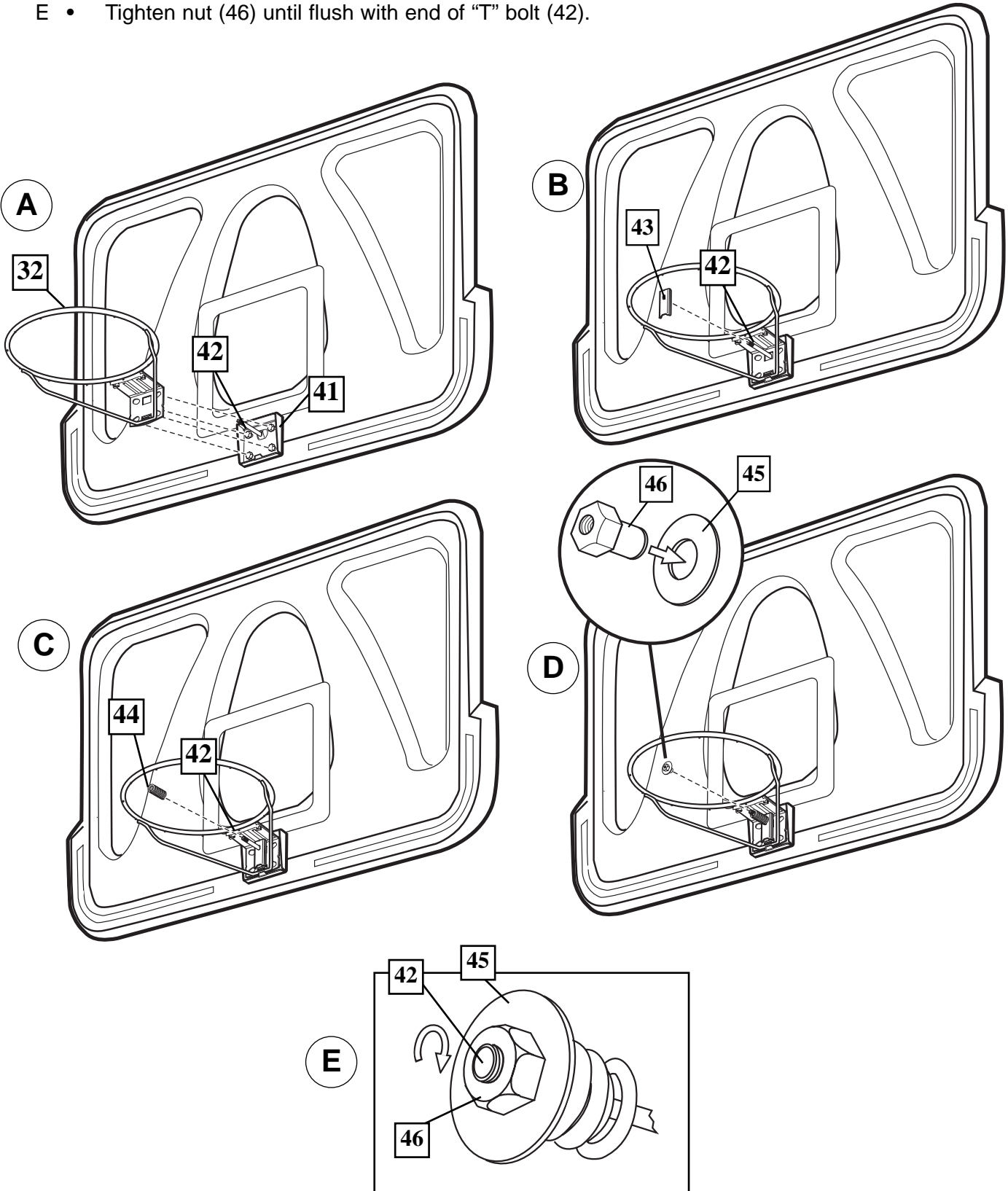

- 4.** Insert bolt (27) through left side of short elevator tube (30), then stretch spring or springs (29) onto bolt (27). Insert bolt (27) through right side of short elevator tube (30) and secure with nut (24).



**! WARNING!**  
USE EYE PROTECTION  
WHEN INSTALLING  
SPRINGS.

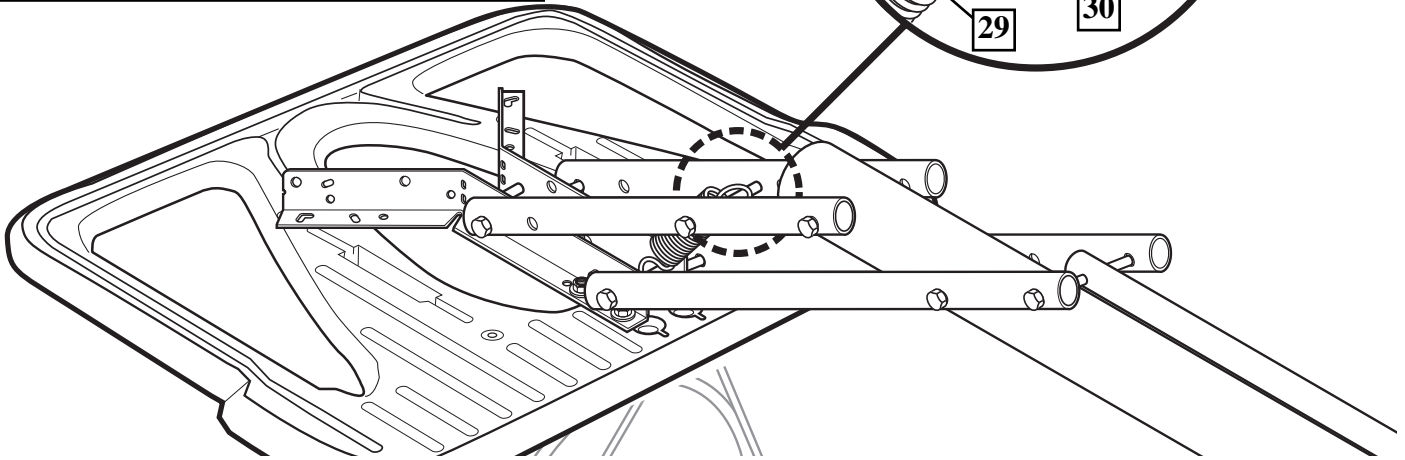
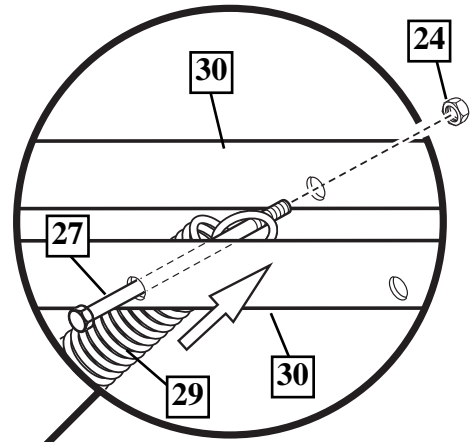

- 5.** Assemble rebar centering spacers (51) near top and bottom of rebar (50) as shown.

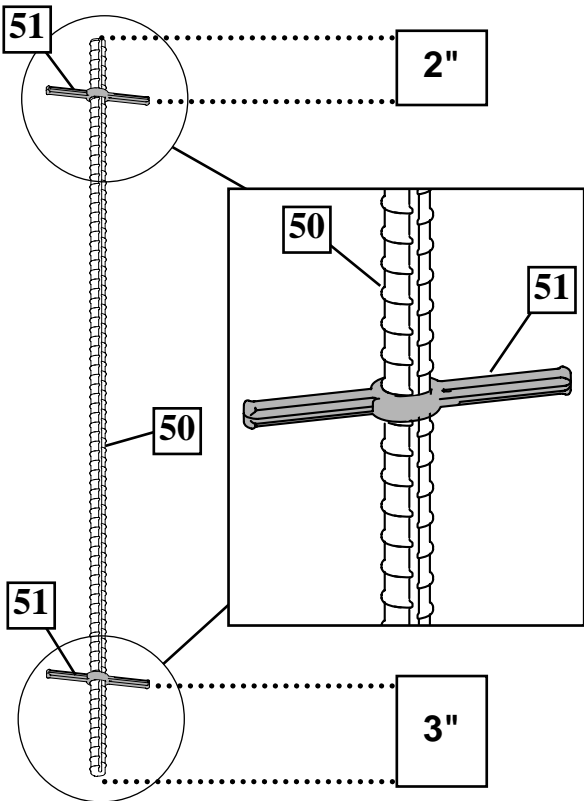

- 6.** Place rebar with spacers into bottom pole section (3) as shown.

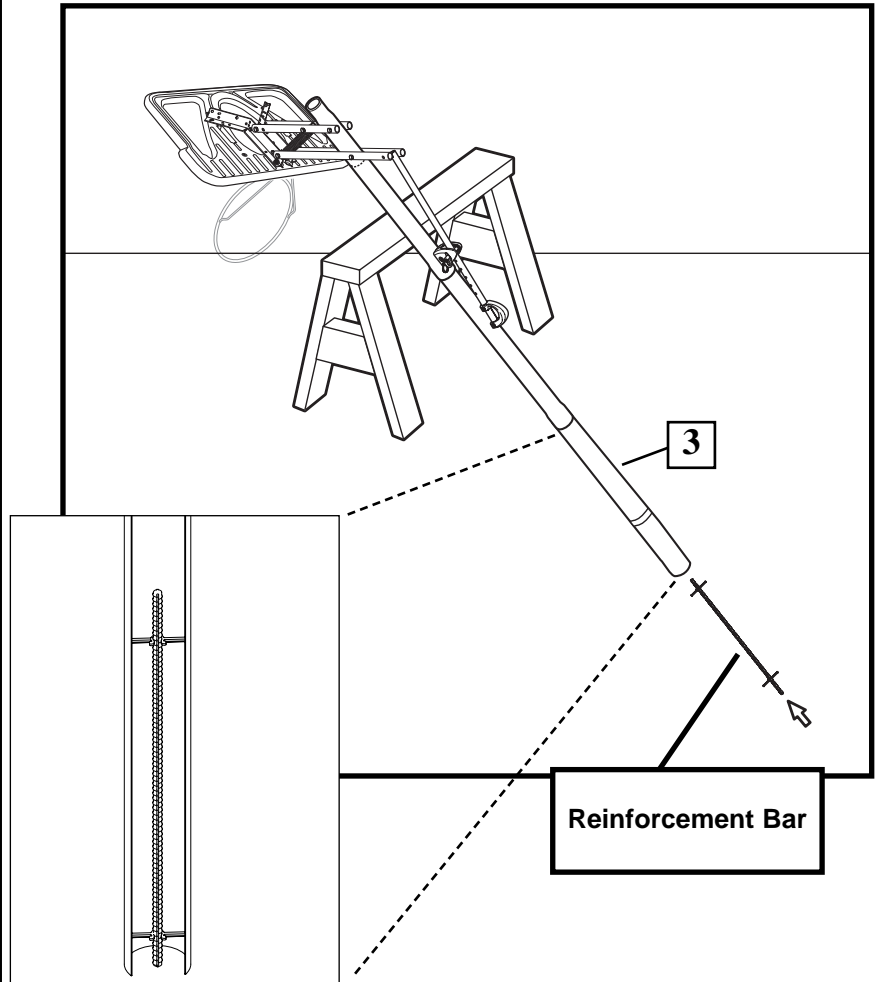

- 7.** Seal hole at the bottom of the bottom pole with heavy-duty tape (not included) to retain rebar and concrete inside.

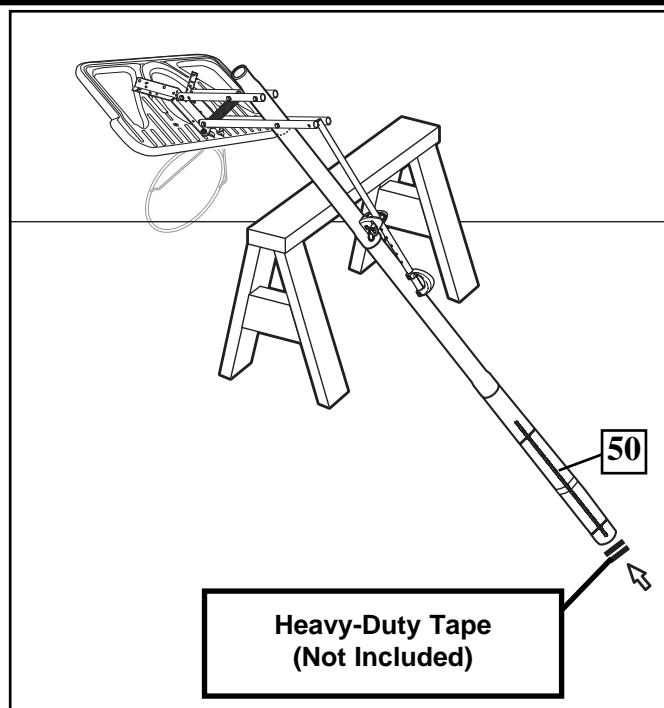

- 8.** Fill pole with concrete approximately 1" (2.54 cm) below bottom elevator hole as shown.

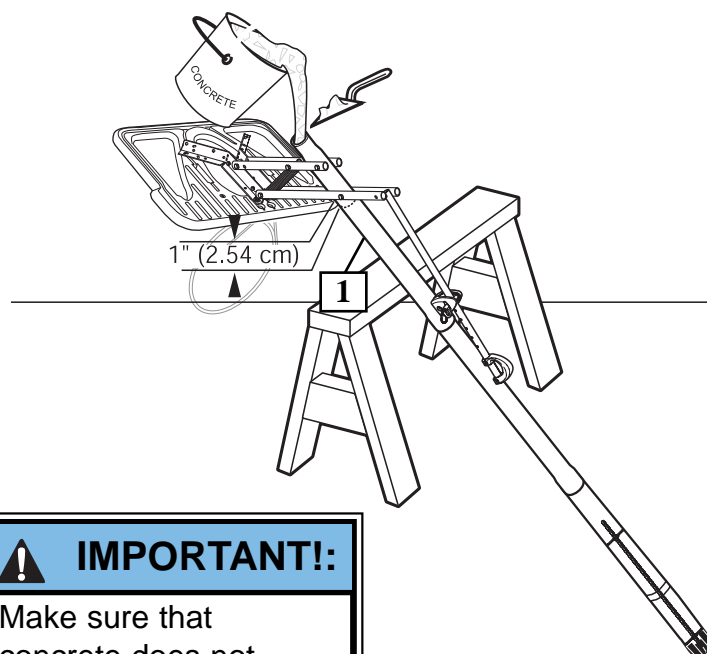

**IMPORTANT!:**

FAILURE TO FILL YOUR POLE COMPLETELY WITH CONCRETE AS DESCRIBED IN THESE INSTRUCTIONS WILL VOID ALL WARRANTIES WRITTEN AND IMPLIED.



**IMPORTANT!:**

Make sure that concrete does not bulge from the end of pole assembly. Allow concrete to completely cure.

**IMPORTANT!:**

WAIT A MINIMUM OF 24 HOURS BEFORE GOING ON TO NEXT STEP. CONCRETE MUST CURE.

9.

Install clips.



**WARNING!**

USE OF THIS PRODUCT WITHOUT PROPER INSTALLATION OF SMART CLIPS®, OR WHEN ALL SMART CLIPS® ARE NOT PRESENT COULD RESULT IN BODILY HARM. BE SURE TO FOLLOW DIRECTIONS CAREFULLY.

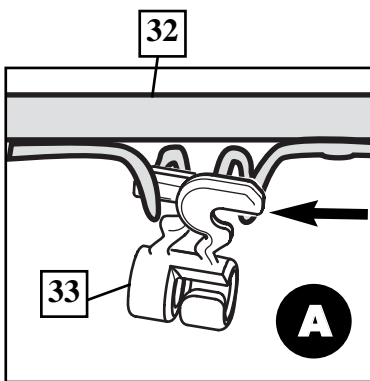
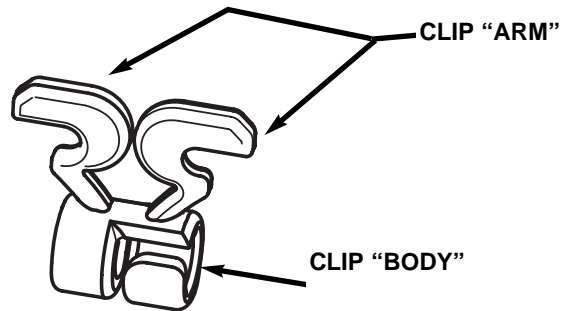

Insert one "arm" of clip into ram as shown. Twist "body" of clip slightly so that second "arm" slides over the top of the first "arm" as shown. Push in direction indicated by arrows.

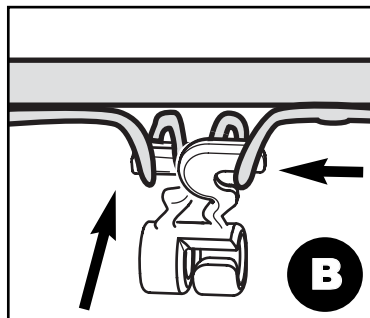

Push second "arm" back and into ram as shown.

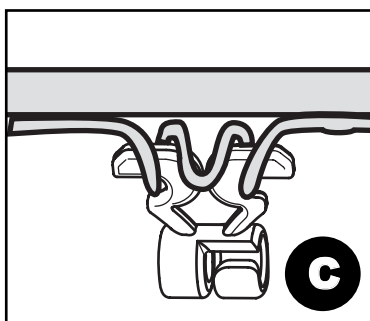

Twist "body" of clip slightly again to spread "arms" of clip. Clip "arms" must be flat and touching edge to edge as shown, not overlapping.



# NET INSTALLATION

10.

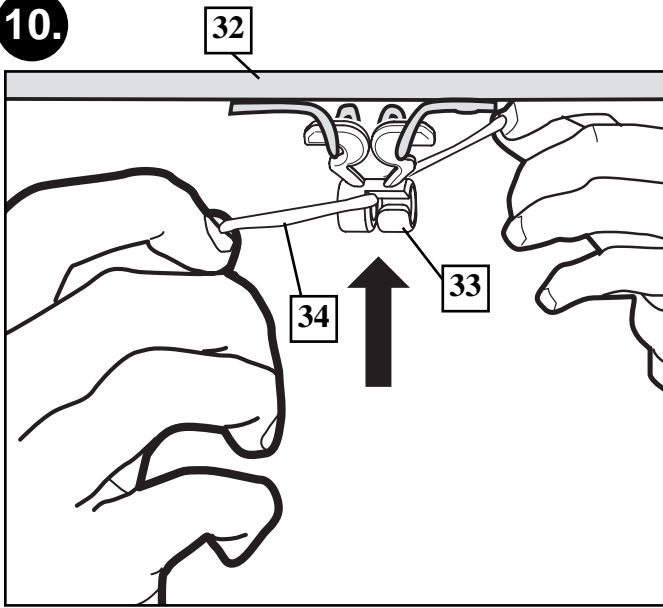

Insert net into bottom of clip as shown.

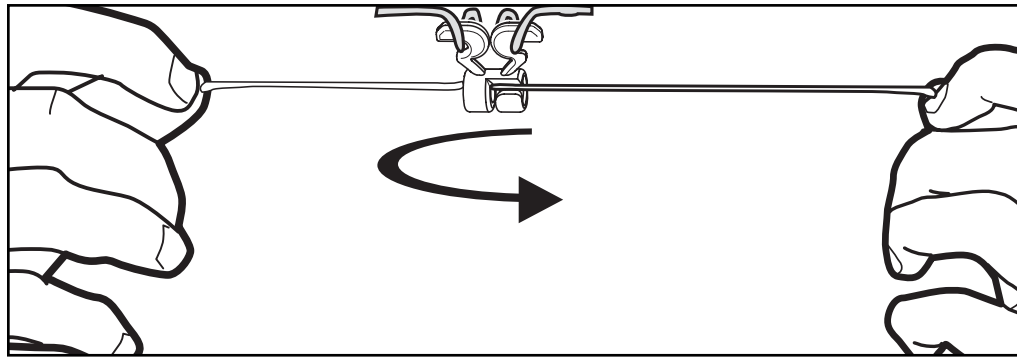

Twist net until it snaps into position. Net must be centered through clip.

SIDE VIEW

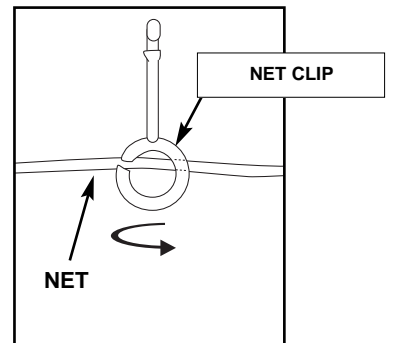
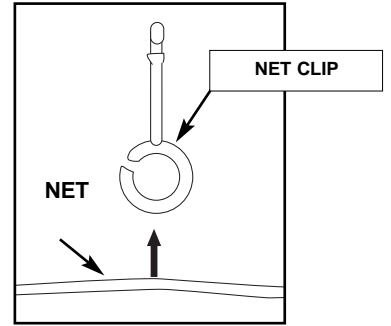

# SECTION D: UPRIGHT, SECURE AND USE POLE SYSTEM

This is what your system will look like when you've finished this section:

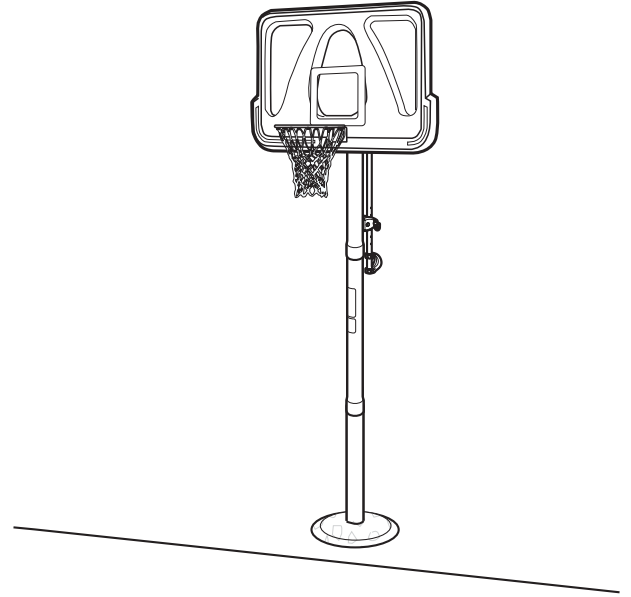

## TOOLS REQUIRED FOR THIS SECTION

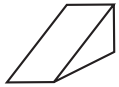

Wedge



Hammer

## HARDWARE USED IN THIS SECTION (not actual size)

**None**

1. After concrete has cured, remove tape, install pole cap (26), fit pole assembly into sleeve (4).

**WARNING!** 

USE CAUTION;  
ASSEMBLY IS HEAVY.

TWO PEOPLE REQUIRED FOR THIS  
PROCEDURE. FAILURE TO FOLLOW  
THIS WARNING COULD RESULT IN  
SERIOUS INJURY AND/OR  
PROPERTY DAMAGE.

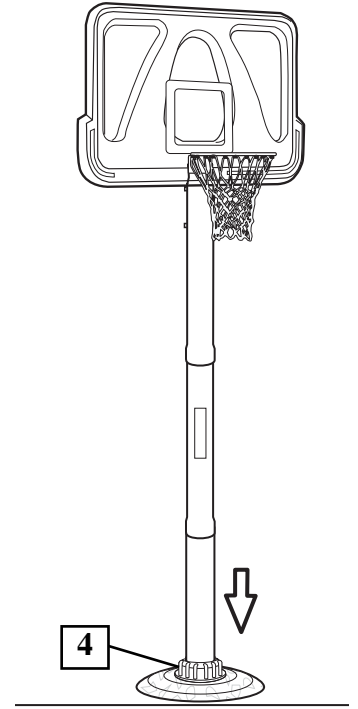
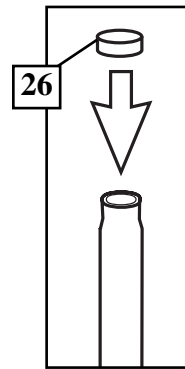

PLAYING SURFACE

2. Use wedge to gently tap cap of ground sleeve (5) until tight.

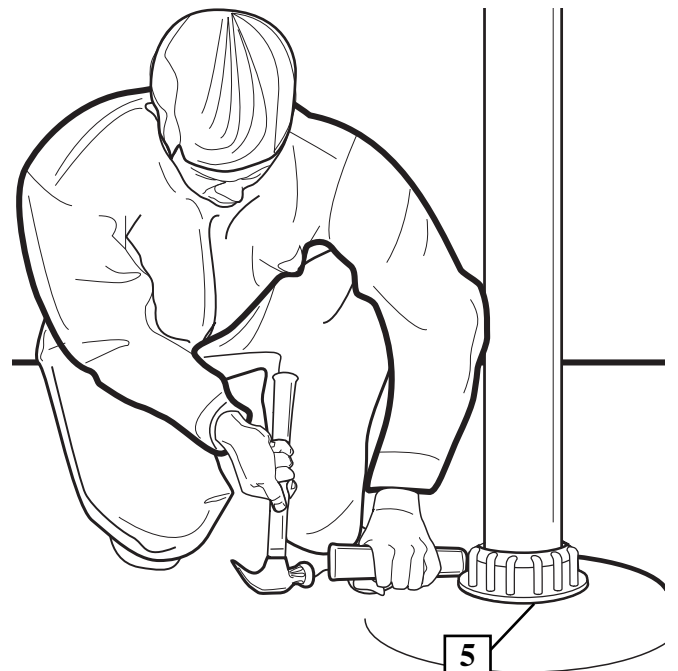

- 3.** A. While holding handle, remove pin (16).  
 B. Move elevator up or down to desired height.  
 C. Replace pin (16) full length to lock system at desired height.

**! WARNING!**  
 DO NOT ALLOW CHILDREN TO ADJUST HEIGHT.

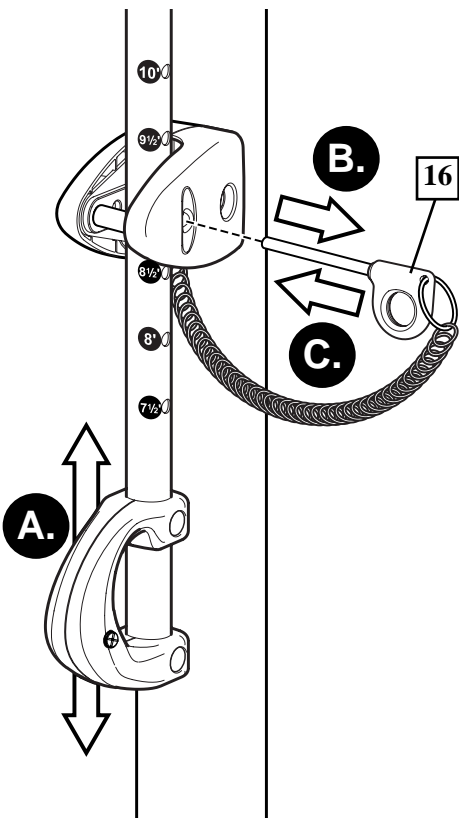

- 4.** Apply height adjustment label (35) to front of pole as shown. Regulation rim height is 10 feet (3.05 m).

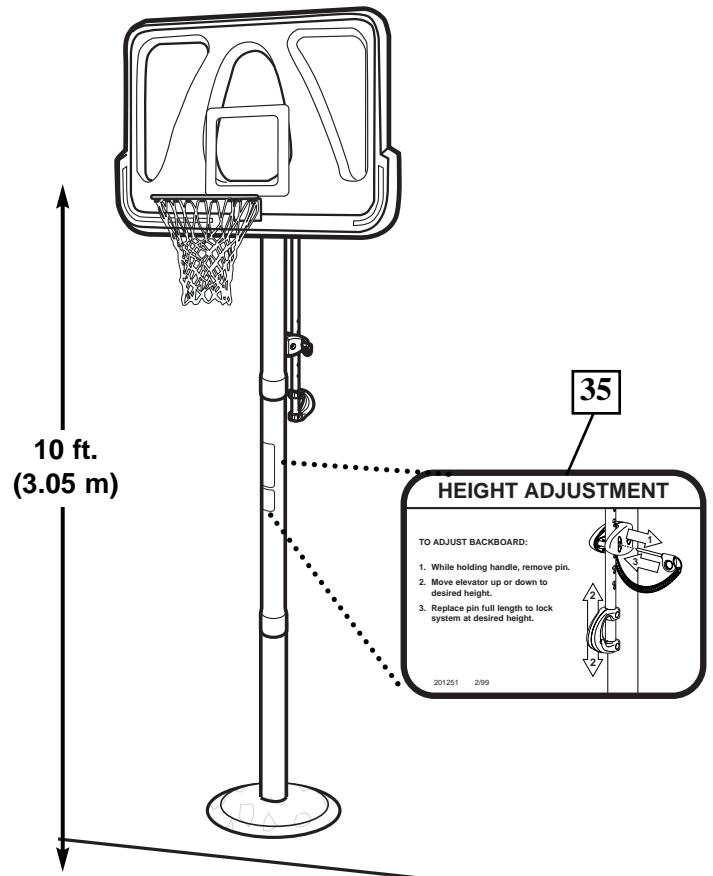

## Free Manuals Download Website

<http://myh66.com>

<http://usermanuals.us>

<http://www.somanuals.com>

<http://www.4manuals.cc>

<http://www.manual-lib.com>

<http://www.404manual.com>

<http://www.luxmanual.com>

<http://aubethermostatmanual.com>

Golf course search by state

<http://golfingnear.com>

Email search by domain

<http://emailbydomain.com>

Auto manuals search

<http://auto.somanuals.com>

TV manuals search

<http://tv.somanuals.com>