

**OEM FUNCTIONAL SPECIFICATION  
ULTRASTAR XP (DFHC) SSA MODELS  
1.12/2.25 GB - 1.0" HIGH  
4.51 GB - 1.6" HIGH  
3.5 FORM FACTOR DISK DRIVE  
VERSION 5.0**

August 15, 1995  
Publication number 3304

**IBM Corporation**

This document is preliminary and the contents are subject to change without notice. Equiries, suggestions, and requests for additional copies may be directed to:

OEM Engineering  
IBM Corporation  
5600 Cottle Road  
San Jose, CA 95193 (USA)

IBM may use any information that you supply without incurring any obligation.

IBM may have patents or pending patent applications covering subject matter in this document. The furnishing of this document does not give you any license to these patents. You can send license inquiries, in writing, to:

Director of Commercial Relations  
IBM Corporation  
A r m o n k NY 10577 USA

**©Copyright International Business Machines Corporation 1994. All rights reserved.**

Note to U.S. Government Users —Documentation related to restricted rights —Use, duplication or disclosure subject to restrictions set forth in GSA ADP Schedule Contract with IBM Corp.

---

## Preface

This document details the product hardware specification for the **Ultrastar XP SSA** family of Direct Access Storage Devices. The capacity model offerings are 1.12, 2.25, and 4.51 GBytes (see 2.1.1, "Capacity Equations" on page 13 for exact capacities based on model and block size). The form factor offerings are 'Brick On Sled' carrier and 3.5-inch small form factor (refer to 4.1.1, "Weight and Dimensions" on page 51 for exact dimensions).

This document, in conjunction with the *Ultrastar XP (DFHC) SSA Models Interface Specification*, make up the Functional Specification for the Ultrastar XP SSA (DFHC) product.

The product description and other data found in this document represent IBM's design objectives and is provided for information and comparative purposes. Actual results may vary based on a variety of factors and the information herein is subject to change. **THIS PRODUCT DATA DOES NOT CONSTITUTE A WARRANTY, EXPRESS OR IMPLIED.** Questions regarding IBM's warranty terms or the methodology used to derive the data should be referred to your IBM customer representative.

**Note:** Not all models described in this document are in plan. Contact your IBM customer representative for actual product plans.



# Contents

<b>1.0 Description</b>	9
1.1 Features	9
1.1.1 General Features	9
1.1.2 Performance Summary	9
1.1.3 Interface Controller Features	9
1.1.4 Reliability Features	10
1.2 Models	10
<b>2.0 Specifications</b>	11
2.1 General	11
2.1.1 Capacity Equations	13
2.2 Power Requirements by Model	15
2.2.1 C1x Models	15
2.2.2 C2x Models	21
2.2.3 C4x Models	27
2.2.4 CxB Models	33
2.2.5 Power Supply Ripple	34
2.2.6 Grounding Requirements of the Disk Enclosure	34
2.2.7 Hot plug/unplug support	34
2.2.8 Bring-up Sequence (and Stop) Times	36
<b>3.0 Performance</b>	39
3.1 Environment Definition	39
3.2 Workload Definition	39
3.2.1 Sequential	40
3.2.2 Random	40
3.3 Command Execution Time	40
3.3.1 Basic Component Descriptions	40
3.3.2 Comments	42
3.4 Approximating Performance for Different Environments	43
3.4.1 For Different Transfer Sizes	44
3.4.2 When Read Caching is Enabled	44
3.4.3 When Write Caching is Enabled	44
3.4.4 When Adaptive Caching is Enabled	44
3.4.5 When Read-ahead is Enabled	44
3.4.6 When No Seek is Required	45
3.4.7 For Queued Commands	45
3.4.8 Out of Order Transfers	45
3.5 Skew	46
3.5.1 Cylinder to Cylinder Skew	46
3.5.2 Track to Track Skew	46
3.6 Idle Time Functions	47
3.6.1 Servo Run Out Measurements	48
3.6.2 Servo Bias Measurements	48
3.6.3 Predictive Failure Analysis	48
3.6.4 Channel Calibration	48
3.6.5 Save Logs and Pointers	49
3.6.6 Disk Sweep	49
3.6.7 Summary	49
3.7 Command Timeout Limits	49

<b>4.0 Mechanical</b>	51
4.1 Small Form Factor Models (CxC)	51
4.1.1 Weight and Dimensions	51
4.1.2 Clearances	51
4.1.3 Mounting	51
4.1.4 Unitized Connector Locations	55
4.2 Carrier Models (CxB)	57
4.2.1 Weight and Dimensions	57
4.2.2 Clearances	57
4.2.3 Mounting	57
4.2.4 Auto-docking Assembly Side Rails	60
4.2.5 Electrical Connector and Indicator Locations	62
<b>5.0 Electrical Interface</b>	63
5.1 SSA Unitized Connector	63
5.2 Carrier Connector	64
5.3 SSA Link Cable	66
5.4 SSA Link Electrical Characteristics	66
5.5 Option Pins and Indicators	66
5.5.1 - Manufacturing Test Mode (Option Port Pin 1)	66
5.5.2 - Auto Start Pin (Option Port Pin 2)	66
5.5.3 - Sync Pin (Option Port Pin 3)	66
5.5.4 - Write Protect (Option Port Pin 4)	67
5.5.5 - Ground long (Option Port Pin 5)	67
5.5.6 - Device Activity Pin/Indicator (Option Port Pin 6)	67
5.5.7 + 5V (Option Port Pin 7)	67
5.5.8 - Device Fault Pin/Indicator (Option Port Pin 8)	67
5.5.9 Programmable pin 1 (Option Port Pin 9)	68
5.5.10 Programmable pin 2 (Option Port Pin 10)	68
5.5.11 - Early Power Off Warning or Power Fail (Power Port Pin 11)	68
5.5.12 12V Charge and 5V Charge (Power Port pin 1 and 2)	68
5.6 Front Jumper Connector	68
5.7 Spindle Synchronization	69
5.7.1 Synchronization overview	69
5.7.2 Synchronization Mode	69
5.7.3 Synchronization time	69
5.7.4 Synchronization with Offset	69
5.7.5 Synchronization Route	69
<b>6.0 Reliability</b>	73
6.1 Error Detection	73
6.2 Data Reliability	73
6.3 Seek Error Rate	73
6.4 Power On Hours Examples:	73
6.5 Power on/off cycles	74
6.6 Useful Life	74
6.7 *Mean Time Between Failure (*MTBF)	75
6.7.1 Sample Failure Rate Projections	75
6.8 SPQL (Shipped product quality level)	75
6.9 Install Defect Free	75
6.10 Periodic Maintenance	76
6.11 ESD Protection	76
6.12 Connector Insertion Cycles	76
<b>7.0 Operating Limits</b>	77

7.1 Environmental	77
7.1.1 Temperature Measurement Points	77
7.2 Vibration and Shock	79
7.2.1 Drive Mounting Guidelines	80
7.2.2 Output Vibration Limits	80
7.2.3 Operating Vibration	80
7.2.4 Operating Shock	82
7.2.5 Nonoperating Shock	82
7.3 Contaminants	82
7.4 Acoustic Levels	83
<b>8.0 Standards</b>	<b>85</b>
8.1 Safety	85
8.2 Electromagnetic Compatibility (EMC)	85
<b>Bibliography</b>	<b>87</b>





---

# 1.0 Description

---

## 1.1 Features

### 1.1.1 General Features

- 1.12/2.25/4.51 gigabytes formatted capacity (512 bytes/sector)
- Serial Storage Architecture (SSA) attachment (dual port)
- Brick On Sled carrier and 3.5" small form factor models
- Rotary voice coil motor actuator
- Closed-loop digital actuator servo (embedded sector servo)
- Magnetoresistive (MR) heads
- (0,8,6,infinity) 8/9 rate encoding
- Partial Response Maximum Likelihood (PRML) data channel with digital filter
- All mounting orientations supported
- Jumperable auto spindle motor start
- Jumperable write protection
- Spindle synchronization
- Two LED drivers
- Bezel (optional)

### 1.1.2 Performance Summary

- Average read seek time (1.12 GB): 6.9 milliseconds
- Average read seek time (2.25 GB): 7.5 milliseconds
- Average read seek time (4.51GB): 8.0 milliseconds
- Average Latency: 4.17 milliseconds
- Split read/write control
- Media data transfer rate: 9.59 to 12.58 MegaBytes/second (10 bands)
- SSA data transfer rate: 20 Megabytes/second

### 1.1.3 Interface Controller Features

- Multiple initiator support
- Supports block sizes from 256 to 5952 bytes
- 512K byte, multi-segmented, dual port data buffer
- Read-ahead caching
- Adaptive caching algorithms
- Write Cache supported (write back & write thru)
- Tagged command queuing
- Command reordering
- Back-to-back writes (merged writes)
- Split reads and writes
- Nearly contiguous read/write
- Link error recovery procedure exit
- Disable registration
- Duplicate tags
- Two byte ULP message codes
- SCSI response
- Move data transfer messages
- Multiple ULP's
- Automatic retry and data correction on read errors

- Automatic sector reallocation
- In-line alternate sector assignment for high-performance
- Improved technique for down-loadable SSA firmware

## 1.1.4 Reliability Features

- Self-diagnostics on power up
- Dedicated head landing zone
- Automatic actuator latch
- Embedded Sector Servo for improving on-track positioning capability
- Buffer memory parity
- Longitudinal Redundancy Check (LRC) on Customer Data
- ECC on the fly
- Error logging and analysis
- Data Recovery Procedures (DRP)
- Predictive Failure Analysis™ (PFA &tm)
- No preventative maintenance required
- Two Field Replaceable Units (FRU's): Electronics Card and Head Disk Assembly (HDA)
- Probability of not recovering data: **10 in 10<sup>15</sup>** bits read

## 1.2 Models

The **Ultrastar XP SSA** disk drive is available in various models as shown below.

The **Ultrastar XP SSA** data storage capacities vary as a function of model and user block size. The emerging industry trend is capacity points in multiples of 1.08GB (i.e. 1.08/2.16/4.32) at a block size of 512 bytes. Future IBM products will plan to provide capacities that are consistent with this trend. Users that choose to make full use of the **Ultrastar XP SSA** drive capacity above the standard capacity points may not find equivalent capacity breakpoints in future products.

Model #	Capacity GB (@512 Byte)	Form Factor	Connector Type
C1B	1.12	Brick On Sled Carrier	128-pin HPC
C1C	1.12	3.5-inch Small FF	38-pin Unitized
C2B	2.25	Brick On Sled carrier	128-pin HPC
C2C	2.25	3.5-inch Small FF	38-pin Unitized
C4B	4.51	Brick On Sled carrier	128-pin HPC
C4C	4.51	3.5-inch Small FF	38-pin Unitized
<b>Note:</b> CxB models (C1B, C2B, and C4B) include a DC/DC converter, activity and check indicators.			
<b>Note:</b> Please refer to section 2.1.1, "Capacity Equations" on page 13 for exact capacities based on user block size.			

## 2.0 Specifications

All specifications are nominal values unless otherwise noted.

The **Ultrastar XP SSA** data storage capacities vary as a function of model and user block size. The emerging Industry trend is capacity points in 1.08GB (i.e. 1.08/2.16/4.32) at a block size of 512 bytes. This and future products will always plan to provide capacities that are consistent with this trend. Users that choose to make full use of the **Ultrastar XP SSA** drive capacity above the standard capacity points may not find equivalent capacity breakpoints in future products.

### 2.1 General

**Note:** The recording band located nearest the disk outer diameter (OD) is referred to as 'Notch #1'. While the recording band located nearest the inner diameter (ID) is called 'Notch #10'. 'Average' values are weighted with respect to the number of LBAs per notch when the drive is formatted with 512 byte blocks.

**Data transfer rates**

	Notch #1	Notch #10	Average	
<b>Buffer to/from media</b>	12.58	9.59	12.07	MB/s (instantaneous)
<b>Host to/from buffer</b>	up to 20.0 MB/s (synchronous) (sustained)			

**Data Buffer Size (bytes)** 512 K (See 3.0, "Performance" on page 39 for user data capacity.)

**Rotational speed (RPM)** 7202.7

**Average latency (milliseconds)** 4.17

**Track Density (TPI)** 4352

	Minimum	Maximum	
<b>Recording density (BPI)</b>	96,567	124,970	
<b>Areal density (Megabits/square inch)</b>	420.3	543.9	
<b>(model numbers -&gt;)</b>	C4x	C2x	C1x
<b>Disks</b>	8	4	2
<b>User Data Heads (trk/cyl)</b>	16	8	4

**Seek times (in milliseconds)**

<b>Single cylinder (Read)</b>	0.5	0.5	0.5
<b>(Write)</b>	2.0	2.0	2.0
<b>Average (weighted) (Read)</b>	8.0	7.5	6.9
<b>(Write)</b>	9.5	9.0	8.5
<b>Full stroke (Read)</b>	16.5	15.0	14.0
<b>(Write)</b>	18.0	16.5	15.5

**Note:** Times are typical for a drive population under nominal voltages and casting temperature of 25°C. Weighted seeks are seeks to the cylinders of random logical block addresses (LBAs).

<b>Total Cylinders (tcyl) &amp; User Cylinders (ucyl)</b>	All models tcyl	C4x Models ucyl	C2x Models ucyl	C1x Models ucyl
<b>Notch #1</b>	1893	1879	1877	1872
<b>Notch #2</b>	956	955	955	955
<b>Notch #3</b>	49	48	48	48
<b>Notch #4</b>	310	309	309	309
<b>Notch #5</b>	349	348	348	348
<b>Notch #6</b>	116	115	115	115
<b>Notch #7</b>	214	213	213	213
<b>Notch #8</b>	190	189	189	189
<b>Notch #9</b>	131	130	130	130
<b>Notch #10</b>	208	206	206	206
<b>Sum of all Notches</b>	4416	4392	4390	4385

<b>Spares Sectors/cylinder (spr/cyl)</b>	C4x Models	C2x Models	C1x Models
<b>Notch #1</b>	40	20	10
<b>Notch #2</b>	40	20	10
<b>Notch #3</b>	38	19	10
<b>Notch #4</b>	37	19	9
<b>Notch #5</b>	36	18	9
<b>Notch #6</b>	34	17	9
<b>Notch #7</b>	33	17	8
<b>Notch #8</b>	32	16	8
<b>Notch #9</b>	31	16	8
<b>Notch #10</b>	30	15	7
<b>Last cylinder extra spares (lcspr)</b>	60	30	14

**User bytes/sector (ub/sct)** 256 - 744 (even number of bytes only)

**Sectors/logical block (sct/lba)** 1-8  
 The lowest sct/lba that satisfies the following rules is used...  
 1. Block Length is evenly divisible by a number 2-8.  
 2. Quotient of previous equation is evenly divisible by 2.  
 3. Quotient must be  $\geq 256$  and  $\leq 744$ .

**User bytes/logical block (ub/lba)** 256 - 5952 (See rules for determining sct/lba above for determining supported ub/lba values.)

**Sectors/track (sct/trk)** (See Table 1 on page 13 or contact an IBM Customer Representative for other block lengths.)

User bytes / logical block	Notch #									
	1	2	3	4	5	6	7	8	9	10
256	216	216	216	202	195	180	180	180	180	162
512	135	135	130	126	120	115	112	108	105	100
520	128	128	128	123	115	112	108	105	102	99
522	128	128	128	122	115	112	108	105	102	90
524	128	128	128	120	115	112	108	105	102	90
528	128	128	126	120	112	112	108	105	101	90
600	115	115	115	110	102	101	97	90	90	90
688	102	102	102	98	90	90	90	90	81	78
744	96	96	96	90	90	90	81	78	77	73

Table 1. Gross sectors per track for several block lengths

User bytes / logical block	C4x Models		C2x Models		C1x Models	
	formatted capacity (bytes)	logical blocks / drive	formatted capacity (bytes)	logical blocks / drive	formatted capacity (bytes)	logical blocks / drive
256	3,654,540,800	14,275,550	1,826,312,448	7,134,033	912,135,680	3,563,030
512	4,512,701,440	8,813,870	2,255,098,368	4,404,489	1,126,337,536	2,199,878
520	4,375,536,880	8,414,494	2,186,554,760	4,204,913	1,092,119,600	2,100,230
522	4,374,300,492	8,379,886	2,185,931,898	4,187,609	1,091,803,716	2,091,578
524	4,385,878,952	8,369,998	2,191,716,460	4,182,665	1,094,691,544	2,089,106
528	4,408,629,984	8,349,678	2,203,082,640	4,172,505	1,100,365,728	2,084,026
600	4,512,402,000	7,520,670	2,254,925,400	3,758,209	1,126,282,800	1,877,138
688	4,604,578,976	6,692,702	2,300,969,904	3,344,433	1,149,310,880	1,670,510
744	4,675,830,192	6,284,718	2,336,559,528	3,140,537	1,167,099,408	1,568,682

Table 2. User capacity for several block lengths

## 2.1.1 Capacity Equations

### 2.1.1.1 For Each Notch

The next group of equations must be calculated separately for each notch.

$$\text{user bytes/sector (ub/sct)} = \frac{\text{ub/lba}}{\text{sct/lba}}$$

$$\text{user sectors/cyl (us/cyl)} = (\text{sct/trk})(\text{trk/cyl}) - \text{spr/cyl}$$

$$\text{spares/notch (spr/nch)} = (\text{spr/cyl})(\text{ucyl})$$

**Note:** Add lcspr to the equation above for the notch closest to the inner diameter (#10).

$$\text{user sectors/notch (us/nch)} = (\text{us/cyl})(\text{ucyl})$$

**Note:** Subtract lcspr from the equation above for the notch closest to the inner diameter (#10).

### 2.1.1.2 For Entire Drive

$$\text{spr/drive (spr/drv)} = \sum_{\text{notch} = 1}^{10} \text{spr/nch}$$

$$\text{user sectors/drive (us/drv)} = \sum_{\text{notch} = 1}^{10} \text{us/nch}$$

$$\text{logical blocks/drive (lba/drv)} = \text{INT} \left[ \frac{\text{us/drv}}{\text{sct/lba}} \right]$$

$$\text{user capacity (fcap)} = (\text{lba/drv})(\text{ub/lba})$$

## 2.2 Power Requirements by Model

### 2.2.1 C1x Models

The following voltage specifications apply at the drive power connector. There is no special power on/off sequencing required. The extra power needed for Brick On Sled models and the +38V power option are described in 2.2.4, "CxB Models" on page 33.

#### Input Voltage

- +5 Volts Supply                    5V (± 5% during run and spin-up)
- +12 Volts Supply                12V (± 5% during run) (+5% / -7% during spin-up)

The following current values are the combination measured values of SCSI models and SSA Cx4 model. The differences between SCSI and SSA is +5 V currents. Because of different interface electronics and speed, SSA electronics card requires more +5 V current than SCSI. Read/Write Base Line is 290 ma higher. Idle Average is 500 ma higher. (290ma and 500ma differences were found by measuring SSA Cx4 model). SSA +5 V current numbers are derived from SCSI +5 V current numbers by adding 290ma and 500ma accordingly.

Power Supply Current	Notes	Population Mean	Population Stand. Dev.
+5VDC (power-up)	Minimum voltage slew rate = 4.5 V/sec		
+5VDC (idle avg)		1.23 Amps	0.02 Amps
+5VDC (R/W baseline)		1.25 Amps <sup>1</sup>	0.05 Amps
+5VDC (R/W pulse)	Base-to-peak	.36 Amps	0.06 Amps
+12VDC (power-up)	Minimum voltage slew rate = 7.4 V/sec		
+12VDC (idle avg)		0.28 Amps	0.02 Amps
+12VDC (seek avg)	1 op/sec	0.0027 Amps	0.002 Amps
+12VDC (seek peak)		1.20 Amps <sup>2</sup>	0.02 Amps
+12VDC (spin-up)	3.0 sec max	1.5 Amps <sup>3</sup>	0.1 Amps
Drive power			
Avg idle power		9.51 Watts	.35 Watts
Avg R/W power	30 ops/sec	10.58 Watts	.35 Watts

<sup>1</sup> See Figure 1 on page 18 for a plot of how the read/write baseline and read/write pulse sum together.

<sup>2</sup> The idle average and seek peak should be added together to determine the total 12 volt peak current. See Figure 2 on page 19 for a typical buildup of these currents. Refer to examples on the following page to see how to combine these values.

### 2.2.1.1 Power Calculation Examples

**Note:** The following formulas assume all system ops as a 1 block read or write transfer from a random cylinder while at nominal voltage condition.

**Example 1. Calculate the mean 12 volt average current.**

If we assume a case of 30 operations/second then to compute the sum of the 12 volt mean currents the following is done.

	mean	
+12VDC (idle average)	0.28	amps
+12VDC (seek average) $0.027 * 30 =$	0.081	amps
<b>TOTAL</b>	<b>0.361</b>	<b>amps</b>

**Example 2. Calculate the mean plus 3 sigma 12 volt average current.**

To compute the sum of the 12 volt mean current's 1 sigma value assume all the distributions are normal. Therefore the square root of the sum of the squares calculation applies. Assume a case of 30 operations/second.

	sigma	
+12VDC (idle average)	0.02	amps
+12VDC (seek average) $\text{sqrt}(30*((0.0002)**2))=$	0.001	amps
<b>TOTAL</b>	$\text{sqrt}((0.02)**2+(.001)**2)=0.02$	<b>amps</b>

So the mean plus 3 sigma mean current is  $0.361 + 3*0.02 = 0.42$  amps

**Example 3. Power Calculation.**

Nominal idle drive power =  $(1.23 \text{ Amps} * 5 \text{ Volts}) + (0.28 \text{ Amps} * 12 \text{ Volts}) = 9.51 \text{ Watts}$

Nominal R/W drive power at 30 ops/sec =  $(1.25 \text{ Amps} * 5 \text{ Volts}) + (0.361 \text{ Amps} * 12 \text{ Volts}) = 10.58 \text{ Watts}$

Mean plus 3 sigma drive power for 30 random R/W operations/second. Assume that the 5 volt and 12 volt distributions are independent therefore the square root of the sum of the squares applies.

+5VDC (1 sigma power) $0.05 * 5$	= 0.25	watts
+12VDC (1 sigma power) $0.02 * 12$	= 0.24	watts
Total (1 sigma power) $\text{sqrt}((0.25)**2+(0.24)**2)$	= 0.347	watts
Total power $9.13 + 3 * 0.347$	= 10.2	watts

<sup>3</sup> The current at start is the total 12 volt current required (ie. the motor start current, module current and voice coil retract current). See Figure 3 on page 20 for typical 12 volt current during spindle motor start.



**Example 4. Calculate the 12 volt peak current.**

To compute the sum of the 12 volt peak currents the following is done.

	mean
+12VDC (idle avg)	0.28 amps
+12VDC (seek peak)	1.2 amps
TOTAL	1.48 amps

**Example 5. Calculate the mean plus 3 sigma 12 volt peak current.**

To compute the sum of the 12 volt peak current's 1 sigma value assume all distributions are normal. Therefore the square root of the sum of the squares calculation applies.

	sigma
+12VDC (idle avg)	0.02 amps
+12VDC (seek peak)	0.02 amps

TOTAL  $\text{sqrt}((0.02)**2+(0.02)**2)=0.028$  amps

So the mean plus 3 sigma peak current is  $1.48 + 3*0.028 = 1.56$  amps

*Things to check when measuring 12 V supply current:*

- Null the current probe frequently. Be sure to let it warm up.
- Adjust the power supply to 12.00 V *at the drive terminals*.
- Use a proper window width, covering an integral number of spindle revolutions.
- Measure values at 25 degree C casting temperature.
- Get a reliable trigger for Seek Peak readings.

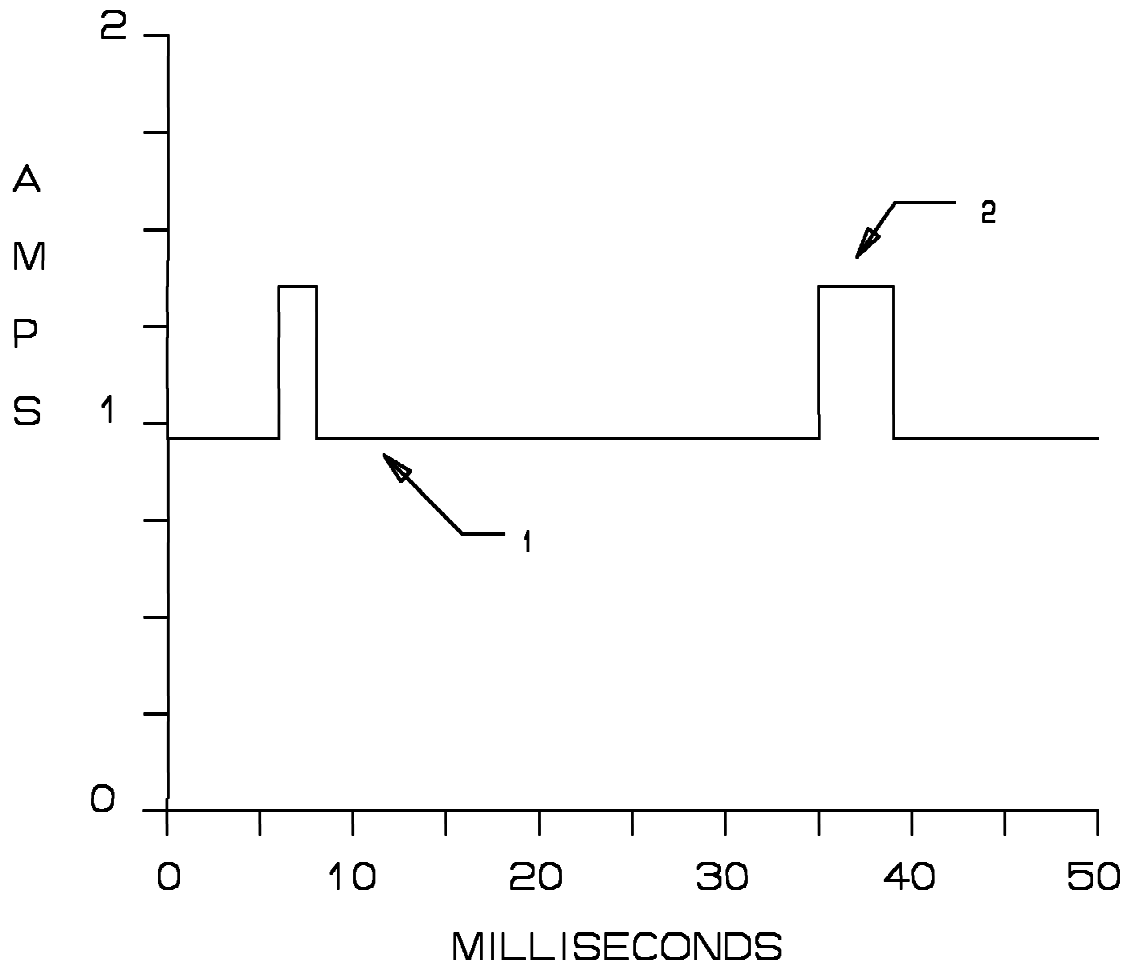

Figure 1. 5 volt current during read/write operations —C1x Models

1. Read/write baseline voltage.
2. Read/write pulse. The width of the pulse is proportional to the number of consecutive blocks read or written. The 5 volt supply must be able to provide the required current during this event.

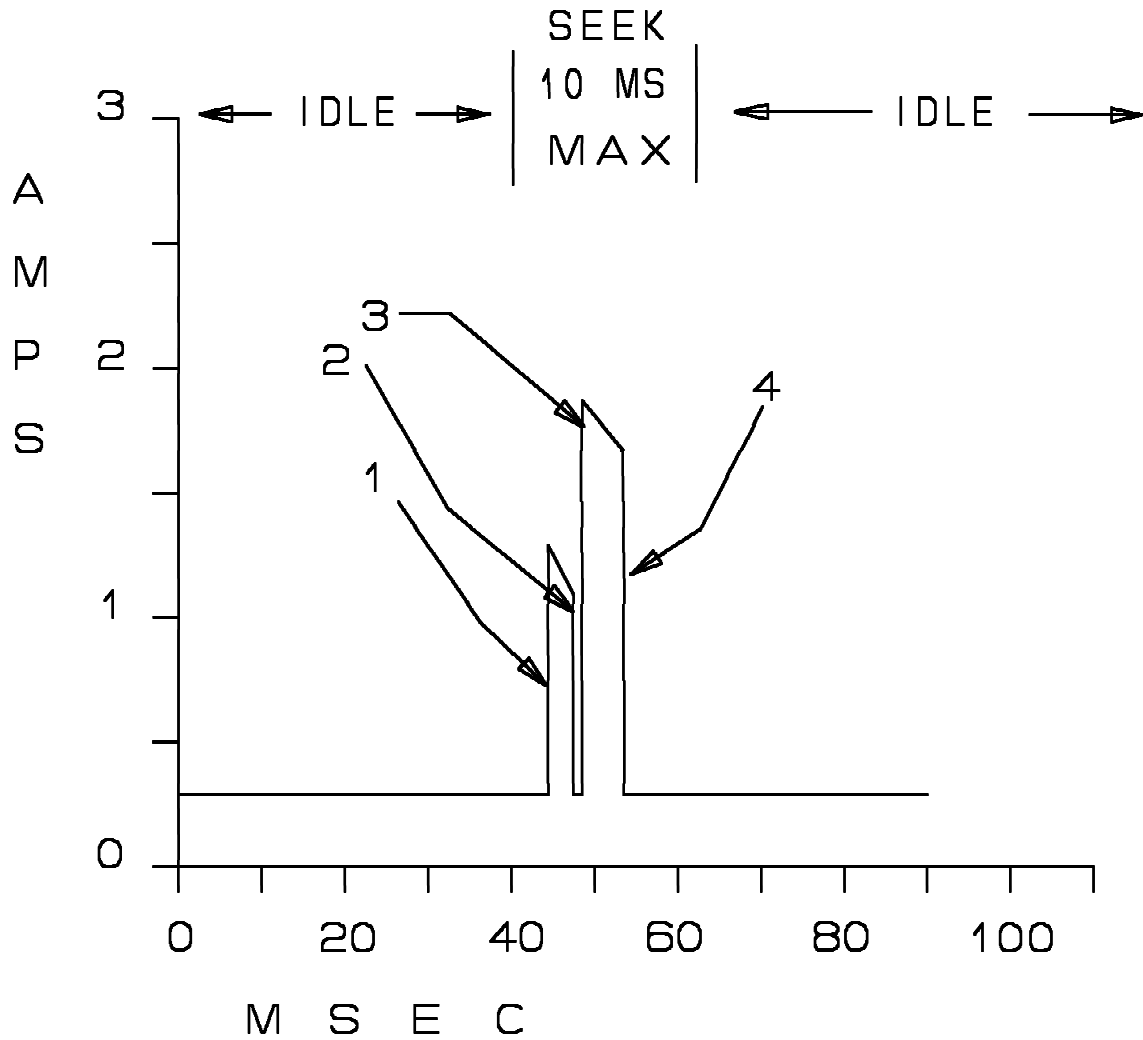

Figure 2. Typical 12 volt current —C1x Models

1. Maximum slew rate is 7 amps/millisecond.
2. Maximum slew rate is 100 amps/millisecond.
3. Maximum slew rate is 7 amps/millisecond.
4. Maximum slew rate is 3 amps/millisecond.

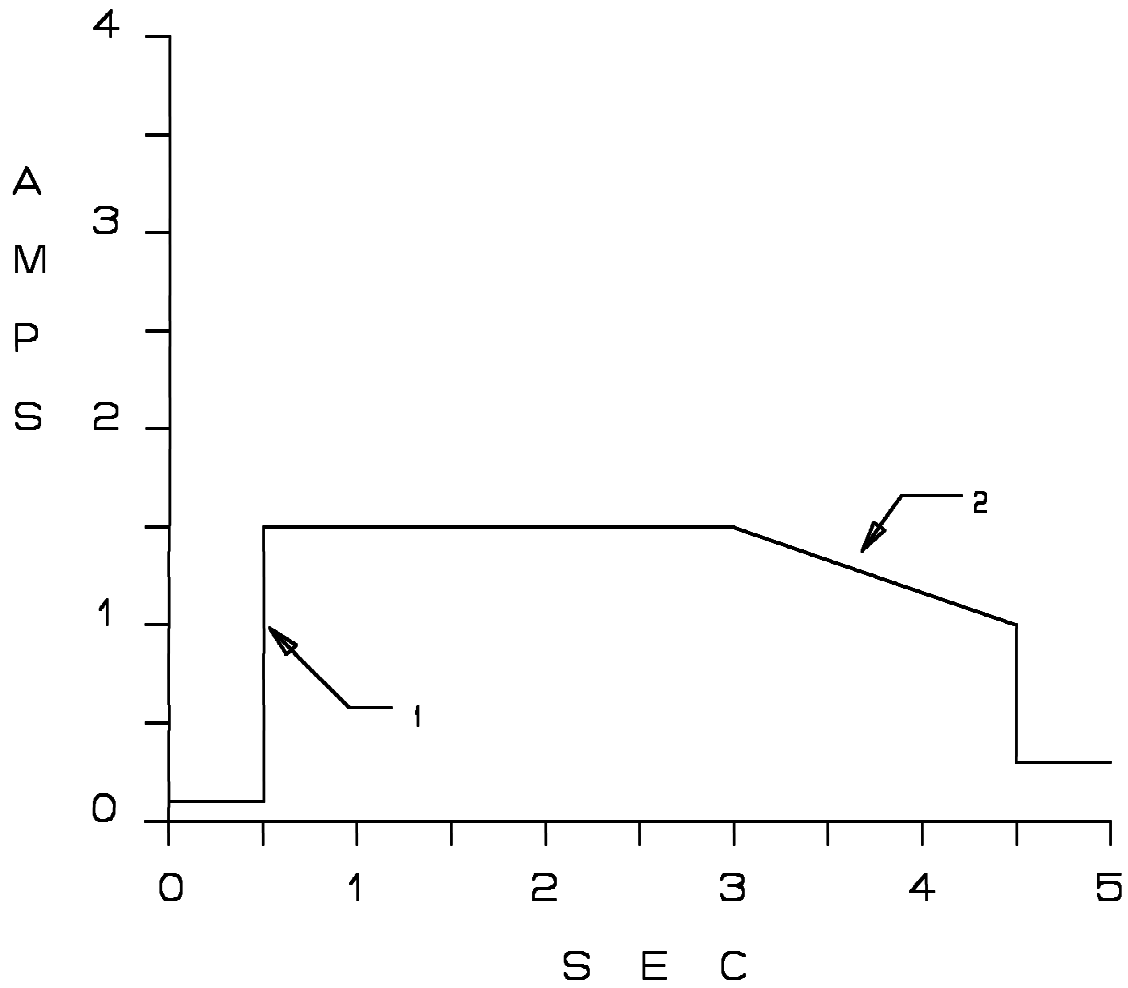

Figure 3. Typical 12 volt spin-up current —C1x Models

1. Maximum slew rate is 20 amps/millisecond.
2. Current drops off as motor comes up to speed.

## 2.2.2 C2x Models

The following voltage specifications apply at the drive power connector. There is no special power on/off sequencing required. The extra power needed for Brick On Sled models and the +38V power option are described in 2.2.4, "CxB Models" on page 33.

### Input Voltage

- +5 Volts Supply            5V (± 5% during run and spin-up)
- +12 Volts Supply        12V (± 5% during run) (+5% / -7% during spin-up)

The following current values are the combination measured values of SCSI models and SSA Cx4 model. The differences between SCSI and SSA is +5 V currents. Because of different interface electronics and speed, SSA electronics card requires more +5 V current than SCSI. Read/Write Base Line is 290 ma higher. Idle Average is 500 ma higher. (290ma and 500ma differences were found by measuring SSA Cx4 model). SSA +5 V current numbers are derived from SCSI +5 V current numbers by adding 290ma and 500ma accordingly.

Power Supply Current	Notes	Population Mean	Population Stand. Dev.
+5VDC (power-up)	Minimum voltage slew rate = 4.5 V/sec		
+5VDC (idle avg)		1.23 Amps	0.02 Amps
+5VDC (R/W baseline)		1.25 Amps <sup>4</sup>	0.05 Amps
+5VDC (R/W pulse)	Base-to-peak	.36 Amps	0.06 Amps
+12VDC (power-up)	Minimum voltage slew rate = 7.4 V/sec		
+12VDC (idle avg)		0.41 Amps	0.02 Amps
+12VDC (seek avg)	1 op/sec	0.0031 Amps	0.0002 Amps
+12VDC (seek peak)		1.20 Amps <sup>5</sup>	0.02 Amps
+12VDC (spin-up)	4.2 sec max	1.5 Amps <sup>6</sup>	0.1 Amps
<b>Drive power</b>			
Avg idle power		11.07 Watts	.35 Watts
Avg R/W power	30 ops/sec	12.25 Watts	.35 Watts

<sup>4</sup> See Figure 4 on page 24 for a plot of how the read/write baseline and read/write pulse sum together.

<sup>5</sup> The idle average and seek peak should be added together to determine the total 12 volt peak current. See Figure 5 on page 25 for a typical buildup of these currents. Refer to examples on the following page to see how to combine these values.

<sup>6</sup> The current at start is the total 12 volt current required (ie. the motor start current, module current and voice coil retract current). See Figure 6 on page 26 for typical 12 volt current during spindle motor start.

### 2.2.2.1 Power Calculation Examples

**Note:** The following formulas assume all system ops as a 1 block read or write transfer from a random cylinder while at nominal voltage condition.

**Example 1. Calculate the mean 12 volt average current.**

If we assume a case of 30 operations/second then to compute the sum of the 12 volt mean currents the following is done.

	mean
+12VDC (idle average)	0.41 amps
+12VDC (seek average) 0.0031 * 30 =	0.09 amps
<b>TOTAL</b>	<b>0.50 amps</b>

**Example 2. Calculate the mean plus 3 sigma 12 volt average current.**

To compute the sum of the 12 volt mean current's 1 sigma value assume all the distributions are normal. Therefore the square root of the sum of the squares calculation applies. Assume a case of 30 operations/second.

	sigma
+12VDC (idle average)	0.02 amps
+12VDC (seek average) $\sqrt{30*((0.0002)**2)}$ =	0.001 amps
<b>TOTAL</b> $\sqrt{(0.02)**2+(.001)**2}$ =	<b>0.02 amps</b>

So the mean plus 3 sigma mean current is  $0.50 + 3*0.02 = 0.56$  amps

**Example 3. Power Calculation.**

Nominal idle drive power =  $(1.23 \text{ Amps} * 5 \text{ Volts}) + (0.41 \text{ Amps} * 12 \text{ Volts}) = 11.07 \text{ Watts}$

Nominal R/W drive power at 30 ops/sec =  $(1.25 \text{ Amps} * 5 \text{ Volts}) + (0.50 \text{ Amps} * 12 \text{ Volts}) = 12.25 \text{ Watts}$

Mean plus 3 sigma drive power for 30 random R/W operations/second. Assume that the 5 volt and 12 volt distributions are independent therefore the square root of the sum of the squares applies.

+5VDC (1 sigma power) 0.05 * 5	= 0.25 watts
+12VDC (1 sigma power) 0.02 * 12	= 0.24 watts
Total (1 sigma power) $\sqrt{(0.25)**2+(0.24)**2}$	= 0.35 watts
Total power 10.8 + 3 * 0.35	= 11.9 watts

**Example 4. Calculate the 12 volt peak current.**

To compute the sum of the 12 volt peak currents the following is done.

	mean
+12VDC (idle avg)	0.41 amps
+12VDC (seek peak)	1.20 amps
<b>TOTAL</b>	<b>1.61 amps</b>

**Example 5. Calculate the mean plus 3 sigma 12 volt peak current.**

To compute the sum of the 12 volt peak current's 1 sigma value assume all distributions are normal. Therefore the square root of the sum of the squares calculation applies.

	sigma
+12VDC (idle avg)	0.03 amps
+12VDC (seek peak)	0.02 amps

TOTAL  $\text{sqrt}((0.03)**2+(0.02)**2)=0.036$  amps

So the mean plus 3 sigma peak current is  $1.61 + 3*0.036= 1.72$  amps

*Things to check when measuring 12 V supply current:*

- Null the current probe frequently. Be sure to let it warm up.
- Adjust the power supply to 12.00 V *at the drive terminals*.
- Use a proper window width, covering an integral number of spindle revolutions.
- Measure values at 25 degree C casting temperature.
- Get a reliable trigger for Seek Peak readings.

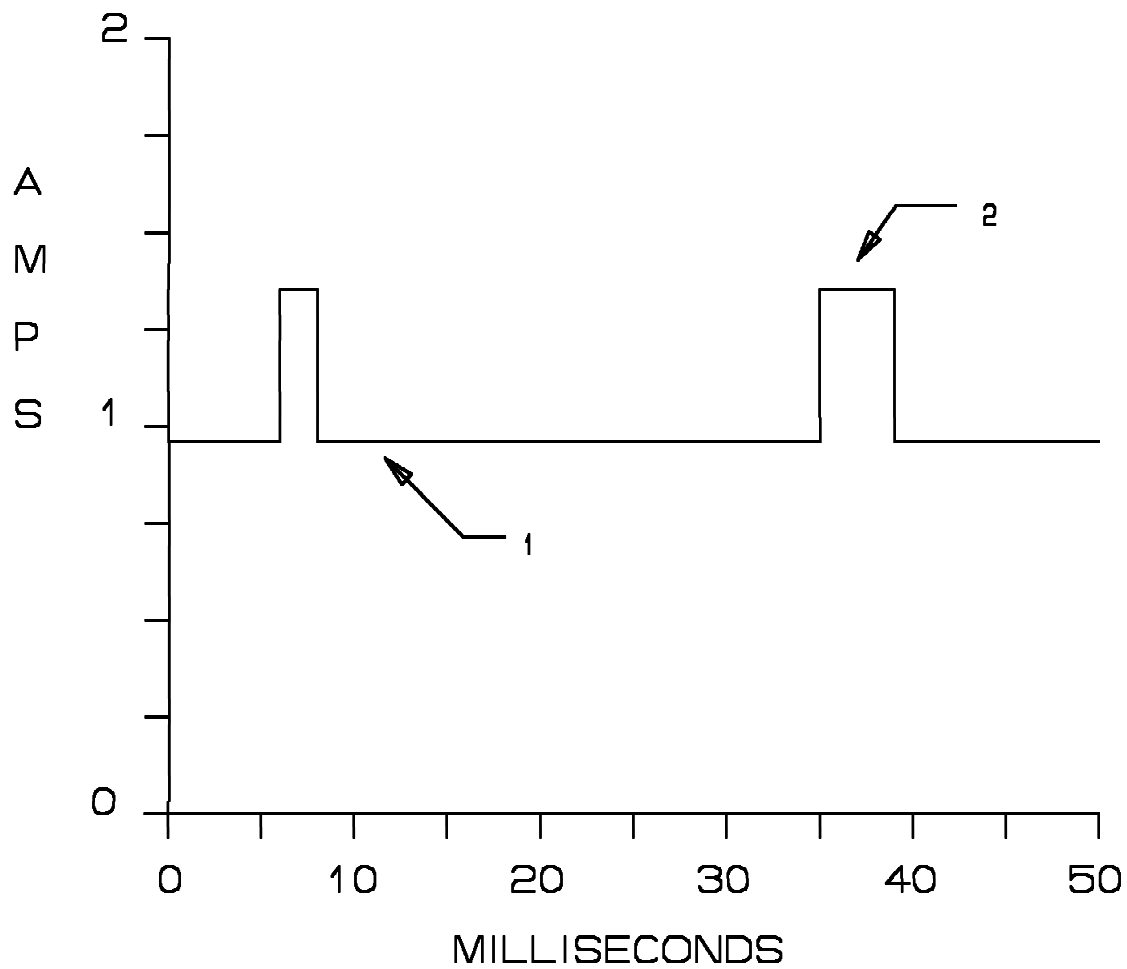

Figure 4. 5 volt current during read/write operations —C2x Models

1. Read/write baseline voltage.
2. Read/write pulse. The width of the pulse is proportional to the number of consecutive blocks read or written. The 5 volt supply must be able to provide the required current during this event.



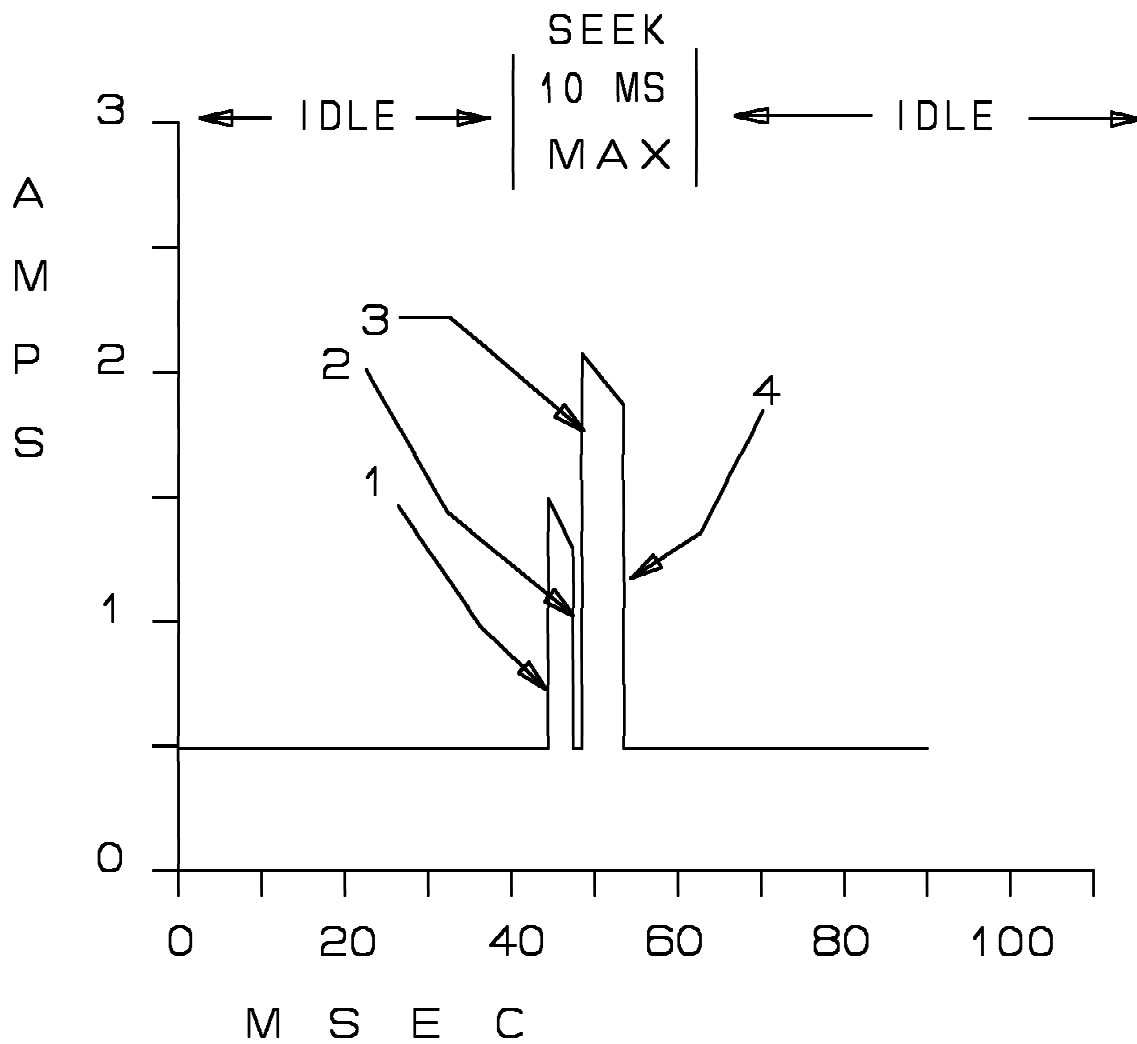

Figure 5. Typical 12 volt current —C2x Models

1. Maximum slew rate is 7 amps/millisecond.
2. Maximum slew rate is 100 amps/millisecond.
3. Maximum slew rate is 7 amps/millisecond.
4. Maximum slew rate is 3 amps/millisecond.

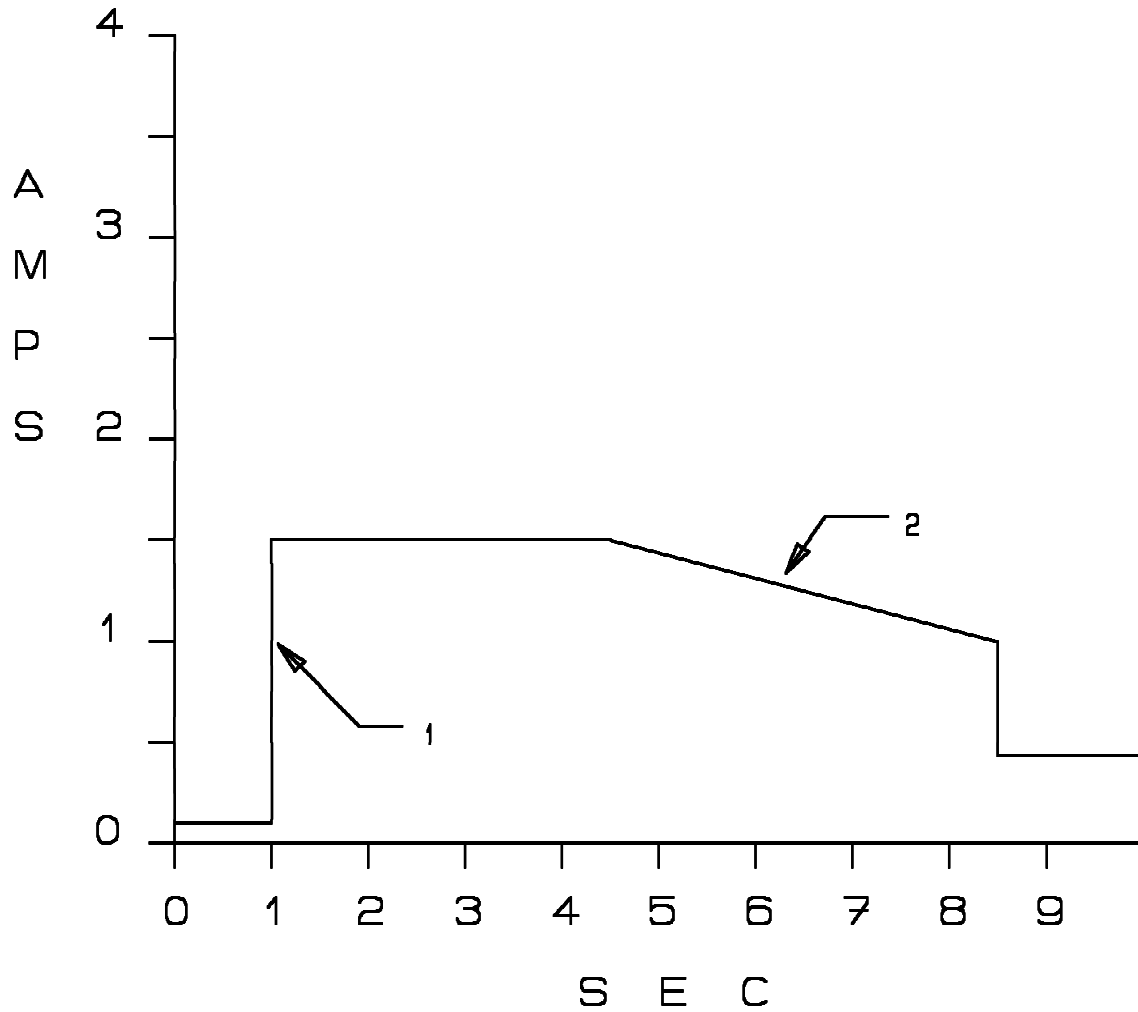

Figure 6. Typical 12 volt spin-up current —C2x Models

1. Maximum slew rate is 20 amps/millisecond.
2. Current drops off as motor comes up to speed.

### 2.2.3 C4x Models

The following voltage specifications apply at the drive power connector. There is no special power on/off sequencing required. The extra power needed for Brick On Sled models and the +38V power option are described in 2.2.4, “CxB Models” on page 33.

#### Input Voltage

- +5 Volts Supply            5V (± 5% during run and spin-up)
- +12 Volts Supply        12V (± 5% during run) (+5% / -7% during spin-up)

The following current values are the combination measured values of SCSI models and SSA Cx4 model. The differences between SCSI and SSA is +5V currents. Because of different interface electronics and speed, SSA electronics card requires more +5V current than SCSI. Read/Write Base Line is 290 ma higher. Idle Average is 500 ma higher. (290ma and 500ma differences were found by measuring SSA Cx4 model). SSA +5V current numbers are derived from SCSI +5V current numbers by adding 290ma and 500ma accordingly.

Power Supply Current	Notes	Population Mean	Population Stand. Dev.
+5VDC (power-up)	Minimum voltage slew rate = 4.5 V/sec		
+5VDC (idle avg)		1.26 Amps	0.02 Amps
+5VDC (R/W baseline)		1.27 Amps <sup>7</sup>	0.05 Amps
+5VDC (R/W pulse)	Base-to-peak	.36 Amps	0.06 Amps
+12VDC (power-up)	Minimum voltage slew rate = 7.4 V/sec		
+12VDC (idle avg)		0.77 Amps	0.03 Amps
+12VDC (seek avg)	1 op/sec	0.0036 Amps	0.0002 Amps
+12VDC (seek peak)		1.3 Amps <sup>8</sup>	0.02 Amps
+12VDC (spin-up)	8.5 sec max	2.2 Amps <sup>9</sup>	0.1 Amps
<b>Drive power</b>			
Avg idle power		15.54 Watts	.44 Watts
Avg R/W power	30 ops/sec	16.91 Watts	.44 Watts

<sup>7</sup> See Figure 7 on page 30 for a plot of how the read/write baseline and read/write pulse sum together.

<sup>8</sup> The idle average and seek peek should be added together to determine the total 12 volt peak current. See Figure 8 on page 31 for a typical buildup of these currents. Refer to examples on the following page to see how to combine these values.

<sup>9</sup> The current at start is the total 12 volt current required (ie. the motor start current, module current and voice coil retract current). See Figure 9 on page 32 for typical 12 volt current during spindle motor start.

### 2.2.3.1 Power Calculation Examples

**Note:** The following formulas assume all system ops as a 1 block read or write transfer from a random cylinder while at nominal voltage condition.

**Example 1. Calculate the mean 12 volt average current.**

If we assume a case of 30 operations/second then to compute the sum of the 12 volt mean currents the following is done.

	mean
+12VDC (idle average)	0.77 amps
+12VDC (seek average) 0.0036 * 30 =	0.11 amps
<b>TOTAL</b>	<b>0.88 amps</b>

**Example 2. Calculate the mean plus 3 sigma 12 volt average current.**

To compute the sum of the 12 volt mean current's 1 sigma value assume all the distributions are normal. Therefore the square root of the sum of the squares calculation applies. Assume a case of 30 operations/second.

	sigma
+12VDC (idle average)	0.02 amps
+12VDC (seek average) $\sqrt{30*((0.0002)**2)}$ =	0.001 amps
<b>TOTAL</b>	$\sqrt{(0.02)**2+(.001)**2}$ =0.02 amps

So the mean plus 3 sigma mean current is  $0.88 + 3*0.02 = 0.94$  amps

**Example 3. Power Calculation.**

Nominal idle drive power =  $(1.26 \text{ Amps} * 5 \text{ Volts}) + (0.77 \text{ Amps} * 12 \text{ Volts}) = 15.54 \text{ Watts}$

Nominal R/W drive power at 30 ops/sec =  $(1.27 \text{ Amps} * 5 \text{ Volts}) + (0.88 \text{ Amps} * 12 \text{ Volts}) = 16.91 \text{ Watts}$

Mean plus 3 sigma drive power for 30 random R/W operations/second. Assume that the 5 volt and 12 volt distributions are independent therefore the square root of the sum of the squares applies.

+5VDC (1 sigma power) $0.05 * 5$	= 0.25 watts
+12VDC (1 sigma power) $0.03 * 12$	= 0.36 watts
Total (1 sigma power) $\sqrt{(0.25)**2+(0.36)**2}$	= 0.44 watts
Total power $15.46 + 3 * 0.44$	= 16.8 watts

**Example 4. Calculate the 12 volt peak current.**

To compute the sum of the 12 volt peak currents the following is done.

	mean
+12VDC (idle avg)	0.77 amps
+12VDC (seek peak)	1.3 amps
<b>TOTAL</b>	<b>2.07 amps</b>

**Example 5. Calculate the mean plus 3 sigma 12 volt peak current.**

To compute the sum of the 12 volt peak current's 1 sigma value assume all distributions are normal. Therefore the square root of the sum of the squares calculation applies.

	sigma
+12VDC (idle avg)	0.02 amps
+12VDC (seek peak)	0.02 amps

TOTAL  $\text{sqrt}((0.02)**2+(0.02)**2)=0.028$  amps

So the mean plus 3 sigma peak current is  $2.07 + 3*0.028= 2.1$  amps

*Things to check when measuring 12 V supply current:*

- Null the current probe frequently. Be sure to let it warm up.
- Adjust the power supply to 12.00 V *at the drive terminals*.
- Use a proper window width, covering an integral number of spindle revolutions.
- Measure values at 25 degree C casting temperature.
- Get a reliable trigger for Seek Peak readings.

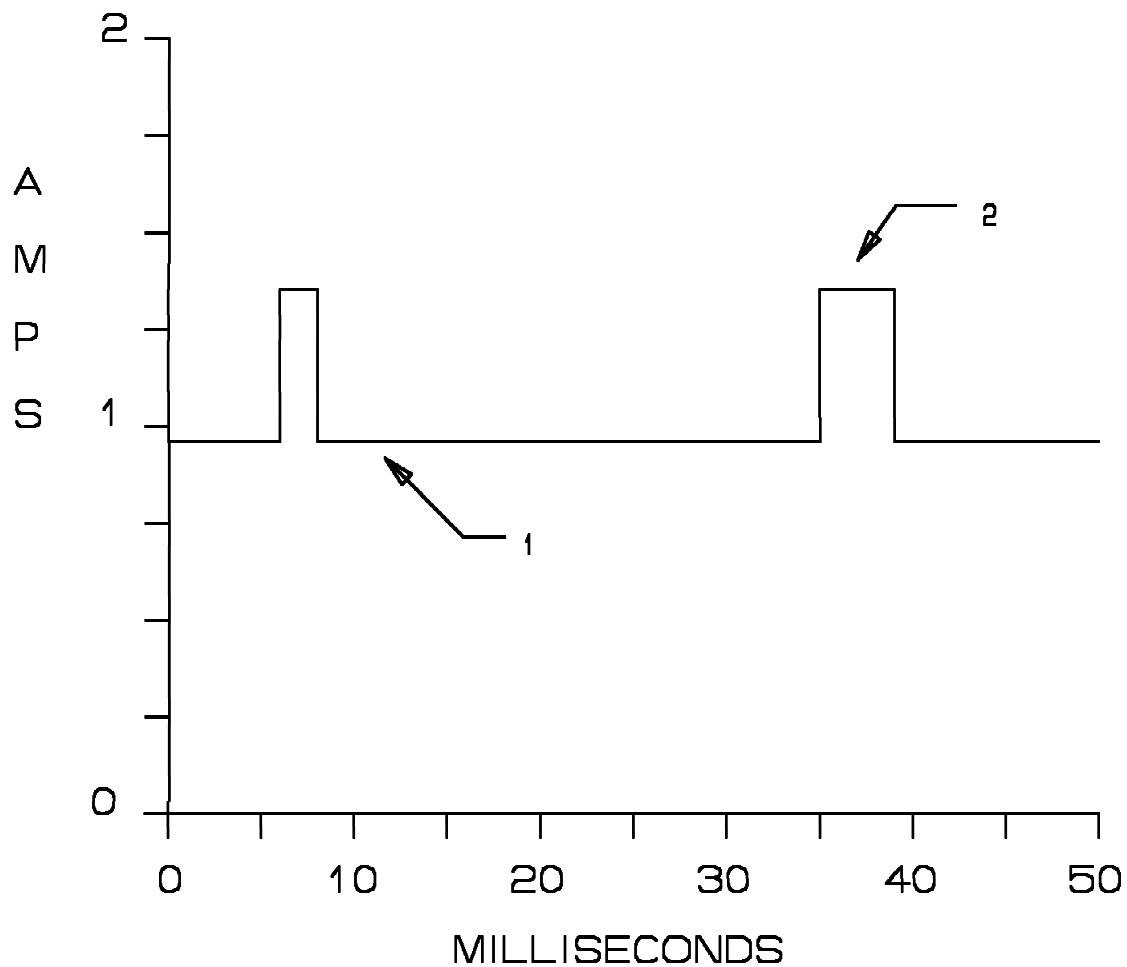

Figure 7. 5 volt current during read/write operations —C4x Models

1. Read/write baseline voltage.
2. Read/write pulse. The width of the pulse is proportional to the number of consecutive blocks read or written. The 5 volt supply must be able to provide the required current during this event.

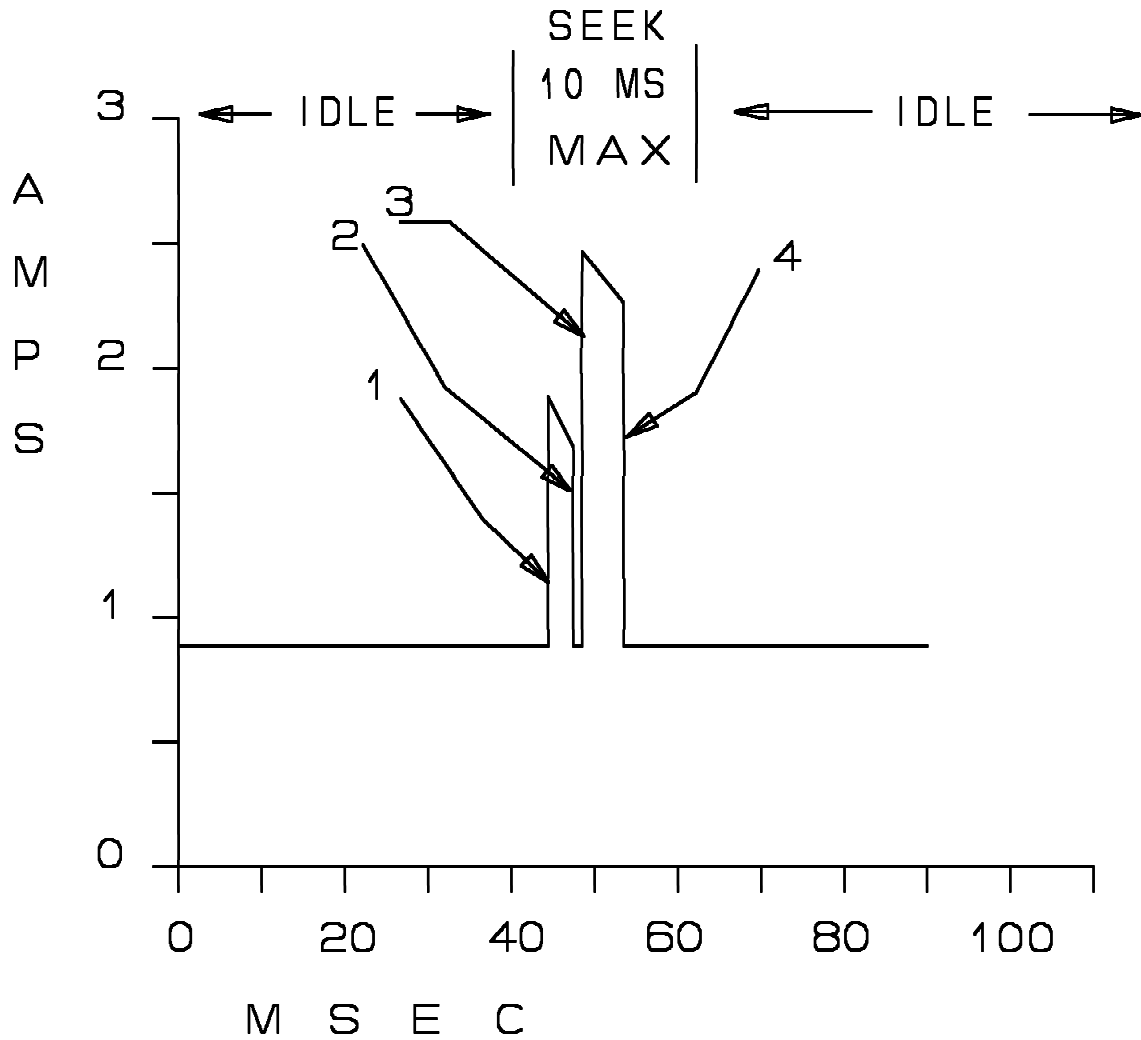

Figure 8. Typical 12 volt current —C4x Models

1. Maximum slew rate is 7 amps/millisecond.
2. Maximum slew rate is 100 amps/millisecond.
3. Maximum slew rate is 7 amps/millisecond.
4. Maximum slew rate is 3 amps/millisecond.

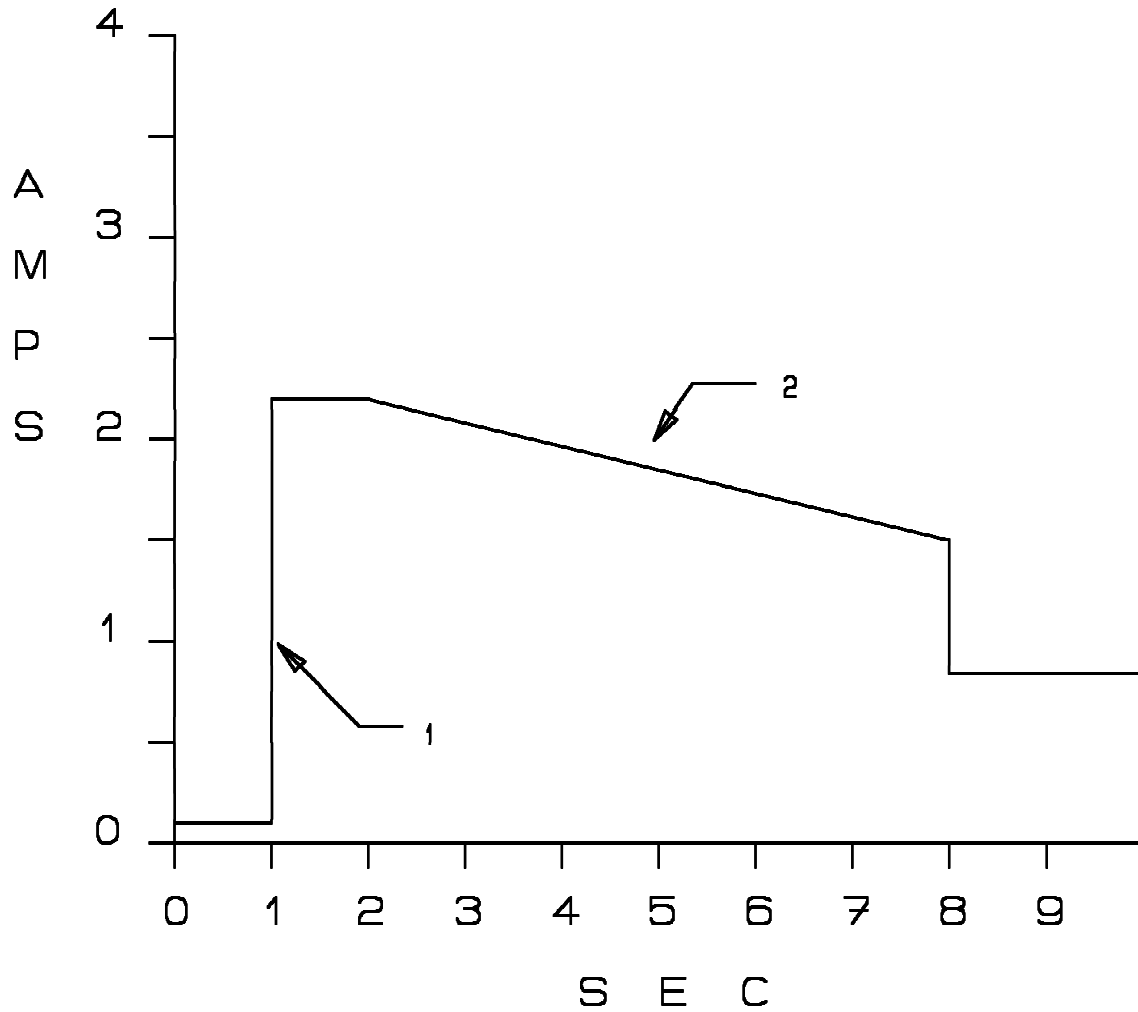

Figure 9. Typical 12 volt spin-up current —C4x Models

1. Maximum slew rate is 20 amps/millisecond.
2. Current drops off as motor comes up to speed.



## 2.2.4 CxB Models

The carrier models include a DC/DC power converter, device activity and fault/service indicators. There is no additional current required for +5V or +12V.

### 2.2.4.1 Power supply methods

When +38V is applied to the interface connector pins **+38V Source A**, **+38V Source B**, and **Ground**, the +38V supply is input to a DC/DC converter that provides +12V and +5V to the drive electronics.

### 2.2.4.2 DC/DC Converter

Typical efficiency of this converter is 80% at maximum output load with input voltage at 38V.

There are two independent +38V power supply inputs on the interface connector which supply two independent inputs to the DC/DC converter, **+38V Source A** and **+38V Source B** (refer to Table 12 on page 65). The DC/DC converter will operate while one input voltage is in the range of +34V to +40V and the other input voltage is in the range of 0 to +40 volts. Input voltage ripple must be less than 1.0 volts peak-to-peak at the fundamental frequency of 420 Hz maximum, less than 500mv at the frequency from 421hz to 1 khz, less than 100mv at the frequency greater than 1 khz. The converter output is +5 volts at 0.3 amps to 2.6 amps and +12 volts at 0.3 amps to 1.4 amps continuous current. The +12v output can handle a surge current of 2.2 amps in 9 seconds.

The total input current to the converter is 1.6A amps when the highest input voltage on the power supply input pins is +34 volts and the converter outputs are operating at full load. The input current ripple, due to converter switching is no more than 100 milliamps peak-to-peak at 1 MHz. Maximum inrush current is limited to 3 amps during turn on except for a maximum period of 2 microseconds (during hot plugging) where the current can exceed 3 amps but is less than 8 amps.

A DC/DC converter output enable is provided on the interface connector. This signal, **+DC/DC Enable**, is pulled up within the converter. To enable the DC outputs, this line must be at or above 2.4 volts. To disable the DC outputs, the signal must be at or below 1.4 volts.

The DC/DC converter has over-current, over-voltage, and over-temperature detection. Any of these conditions will latch off the converter. The latch is reset by insuring that both input voltages fall below +5 volts for a period greater than or equal to 10 milliseconds.

Refer to 5.5, "Option Pins and Indicators" on page 66 for descriptions of the Early Power Off Warning and Loss of Redundancy fault signals associated with the +38V supply inputs.

## 2.2.5 Power Supply Ripple

Externally Generated Ripple<sup>10</sup>  
as seen at drive power connector

	Maximum	Notes
+5VDC	150 mV peak-to-peak	0-20 MHz
+12VDC	150 mV peak-to-peak	0-20 MHz

During drive start up and seeking, 12 volt ripple is generated by the drive (referred to as dynamic loading). If several drives have their power daisy chained together then the power supply ripple plus other drive's dynamic loading must remain within the regulation tolerance window of +/- 5%. A common supply with separate power leads to each drive is a more desirable method of power distribution.

## 2.2.6 Grounding Requirements of the Disk Enclosure

The disk enclosure is at Power Supply ground potential. It is allowable for the user mounting scheme to common the Disk Enclosure to Frame Ground potential or to leave it isolated from Frame Ground.

From a Electro-Magnetic Compatibility (EMC) standpoint it will, in most cases be preferable to common the Disk Enclosure to the system's mounting frame. With this in mind, it is important that the Disk Enclosure not become an excessive return current path from the system frame to power supply. The drive's mounting frame must be within  $\pm 150$  millivolts of the drive's power supply ground. At no time should more than 35 milliamps of current (0 to 100Mhz) be injected into the disk enclosure.

Please contact your IBM Customer Representative if you have questions on how to integrate this drive in your system.

## 2.2.7 Hot plug/unplug support

Power supply and SSA link hot plug and un-plug is allowed for all SSA models.

**For Form Factor models**, there is no special sequence required for connecting 5 volt, 12 volt, or ground. During a hot plug-in event the drive being plugged will draw a large amount of current at the instant of plug-in. This current spike is due to charging the bypass capacitors on the drive. This current pulse may cause the power supply to go out of regulation. If this supply is shared by other drives then a low voltage power on reset may be initiated on those drives. Therefore the recommendation for hot plugging is to have one supply for each drive. Never daisy chain the power leads if hot plugging is planned. Hot plugging should be minimized to prevent wear on the power connector.

**The carrier models** may be hot plugged **ONLY IF** the ground pins (longer pin) make contact first (before other pins which are shorter). Vice versa, the carrier may be hot unplugged **ONLY IF** the ground pins (longer pins) are the last to remove (after other pins which are shorter). **DAMAGE TO THE FILE ELECTRONICS AND THE ADAPTER ELECTRONICS COULD RESULT IF THE ABOVE CONDITIONS ARE NOT MET.** The mating HPC connector **MUST HAVE PROGRAMMABLE PIN LENGTH. GND PINS MUST BE LONGER THAN SIGNAL AND POWER PINS. THE GUIDE PINS MUST BE TIED TO THE DOKING ASSEMBLY FRAME GND**

<sup>10</sup> This ripple must not cause the power supply to the drive to go outside of the  $\pm 5\%$  regulation tolerance.

Hot plugging the SSA link will be recognized by the next node which will cause a configuration process to be started by the Initiators.

During hot plugging, the supplies must not go over the upper voltage limit. This means that proper ESD protection must be used during the plugging event.

During hot un-plugging if the operating shock limit specification can be exceeded then the drive should be issued a Start/Stop Unit command (spin down) that is allowed to complete before un-plugging.

## 2.2.8 Bring-up Sequence (and Stop) Times

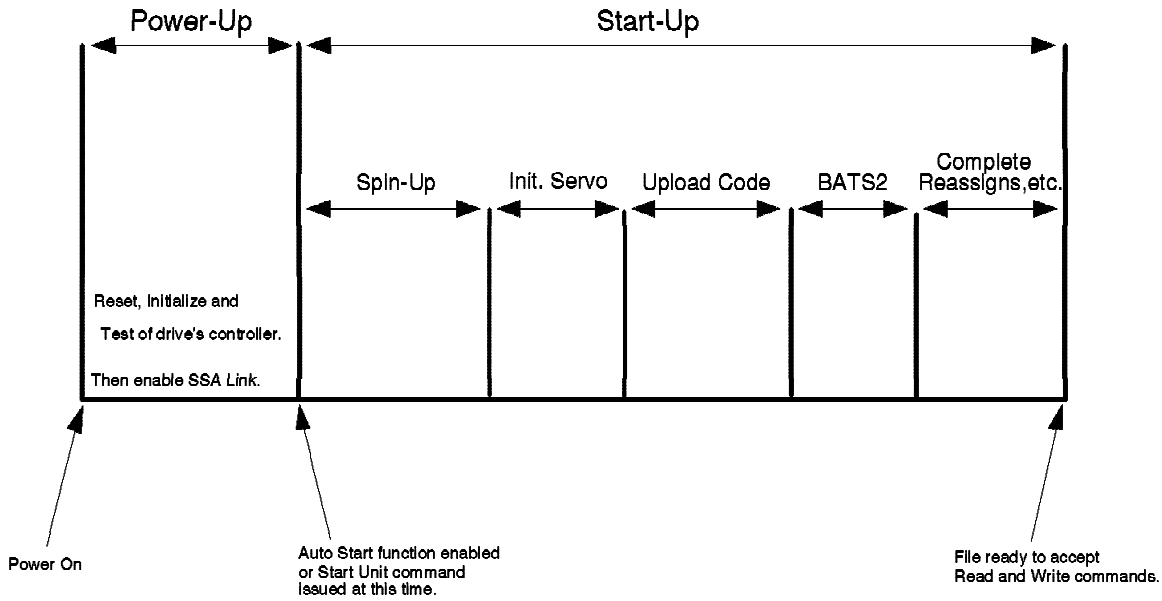

Figure 10. Start Time Diagram

**Note:** BATS is the abbreviation for Basic Assurance Tests. Start-up sequence spins up the spindle motor, initializes the servo subsystem, up-loads code, performs BATS2 (verifies read/write hardware), resumes "Reassign in Progress" operations, and more. For more information on the start-up sequence, refer to the *Ultrastar XP (DFHC) SSA Models Interface Specification*.

**Note:** If a RESET is issued before the drive comes ready, the power on sequence will start again. In all other cases when a RESET is issued the present state of the motor is not altered.

**Note:** Reference "Start/Stop Unit Time" on page 49 for additional details.

**Note:** See 5.7, "Spindle Synchronization" on page 69 for details about Start-up time increases when the device is requested via Mode Parameters to synchronize the spindle motor to another device.

Event	Nominal	Maximum	Notes
Power-up	1.5 sec	2.0 sec	*see Figure 10
Start-up	12.4 sec	45 sec.	*see Figure 10
Spin-up	8.2 sec	29.2 sec	*see Figure 10
Spindle Stop	6.0 sec	12.0 sec	

Table 3. Bring-up Sequence Times and Stop Time for C1x Models

<b>Event</b>	<b>Nominal</b>	<b>Maximum</b>	<b>Notes</b>
Power-up	1.5 sec	2.0 sec	*see Figure 10
Start-up	17.6 sec	45 sec.	*see Figure 10
Spin-up	13.2 sec	29.2 sec	*see Figure 10
Spindle Stop	9.0 sec	12.0 sec	

Table 4. Bring-up Sequence Times and Stop Time for C2x Models

<b>Event</b>	<b>Nominal</b>	<b>Maximum</b>	<b>Notes</b>
Power-up	1.5 sec	2.0 sec	*see Figure 10 on page 36
Start-up	16.5 sec	45 sec.	*see Figure 10 on page 36
Spin-up	11.17 sec	30.9 sec	*see Figure 10 on page 36
Spindle Stop	8.0 sec	12.0 sec	

Table 5. Bring-up Sequence Times and Stop Time for C4x Models



---

## 3.0 Performance

Drive performance characteristics are dependent upon the workloads run and the environments in which they are run.

All times listed in this chapter are typical values provided for information only, so that the performance for environments and workloads other than those shown as examples can be approximated. Actual minimum and maximum values will vary depending upon factors such as workload, logical and physical operating environments.

---

### 3.1 Environment Definition

Drive performance criteria is based on the following operating environment. Deviations from this environment may cause deviations from values listed in this specification.

- Block lengths are formatted at 512 bytes per block.
- The number of data buffer cache segments is 8. The total data buffer length is 512k bytes. Each segment is of equal length. Therefore, each cache segment is 64k bytes.

The number of blocks of customer data that can fit into one segment is reduced because 2 bytes of LRC information is also stored in the segment for each block of customer data stored in the segment. Therefore, use the following equation to determine how many blocks can fit into one segment.

$$\left( \frac{512\text{KB}}{\# \text{ of segments}} \right) \div (\text{ub/lba} + 2)$$

- Ten byte Read and Write commands are used.
- SSA environment consists of a single initiator and single target with no SSA link contention.
- The Initiator delay in responding to messages from the Target is assumed to be zero.
- All performance enhancing functions are disabled, except where noted. More specifically,
  - Commands are not queued
  - Caching is disabled (RCD=1, WCE=0)
  - Out of order transfers are not allowed (OOTM=0, OOTI=0)
- The media is formatted with the skew definition that optimizes the disk data transfer rate for unsynchronized spindle operation.
- All Current Mode Parameters are set to their Default values except where noted.
- Averages are based on a sample size of 10,000 operations.

---

### 3.2 Workload Definition

The drive's performance criteria is based on the following command workloads. Deviations from these workloads may cause deviations from this specification.

- Operations are either all Reads or all Writes. The specifications for Command Execution Time with Read Ahead describe exceptions to this restriction. For that scenario all commands are preceded by a Read command, except for sequential write commands.
- The Data Transfer size is set to 64 Blocks.

- The time between the end of an operation, and when the next operation is issued is 50 msec, +/- a random value of 0 to 50 msec, unless otherwise noted.

### 3.2.1 Sequential

- No Seeks. The target LBA for all operations is the previous LBA + 64.

### 3.2.2 Random

- All operations are to random LBAs. The average seek is an average weighted seek.

---

## 3.3 Command Execution Time

Command execution, or service, times are the sum of several Basic Components:

1. Seek
2. Latency
3. Command Execution Overhead
4. Data Transfer to/from Disk
5. Data Transfer to/from SSA Link

The impact or contribution of those Basic Components to Command Execution Time is a function of the workload being sent to the drive and the environment in which the drive is being operated.

### 3.3.1 Basic Component Descriptions

#### Seek

The average time from the initiation of the seek, to the acknowledgement that the R/W head is on the track that contains the first requested LBA. Values are population averages, and vary as a function of operating conditions. The values used to determine Command Execution Times for sequential commands is 0 milliseconds and the values for random commands are shown in section 2.0, "Specifications" on page 11.

#### Latency

The average time required from the activation of the read/write hardware until the target sector has rotated to the head and the read/write begins. This time is 1/2 of a revolution of the disk, or 4.17 milliseconds.

#### Command Execution Overhead

The average time added to the Command Execution Time due to the processing of the command. It includes all time the drive spends not doing a disk operation or SSA link data transfer.

The following values are used when calculating the Command Execution Times.

Workload	Command Execution
Sequential Read	.65 ms
Sequential Write	1.00 ms
Random Read	.25 ms
Random Write	.30 ms

Table 6. Overhead Values

A number of Initiator controlled factors affect Command Execution Overhead. These are examined separately in 3.4, "Approximating Performance for Different Environments" on page 43.



The *Post Command Processing* time of .26 ms is defined as the average time required for process cleanup after the command has completed. If a re-instruct period faster than this time is used, the difference is added to the Command Execution Overhead of the next operation.

#### **Data Transfer to/from Disk**

The average time used to transfer the data between the media and the drive's internal data buffer. This is calculated from:

$(\text{Data Transferred})/(\text{Media Transfer Rate})$ .

There are four interpretations of Media Transfer Rate. How it is to be used helps decide which interpretation is appropriate to use.

1. Instantaneous Data Transfer Rate

The same for a given notch formatted at any of the supported logical block lengths. It varies by notch only and does not include any overhead.

2. Track Data Sector Transfer Rate

Varies depending upon the formatted logical block length and varies from notch to notch. It includes the overhead associated with each individual sector. This is calculated from:

$(\text{user bytes/sector})/(\text{individual sector time})$

(Contact an IBM Customer Representative for individual sector times of the various formatted block lengths.)

3. Theoretical Data Sector Transfer Rate

Also includes time required for track and cylinder skew and overhead associated with each track. (See 3.3.2.1, "Theoretical Data Sector Transfer Rate" on page 43 for a description on how to calculate it.)

4. Typical Data Sector Transfer Rates

Also includes the effects of defective sectors and skipped revolutions due to error recovery. See Appendix B of the *Ultrastar XP (DFHC) SSA Models Interface Specification* for a description of error recovery procedures.

Rates for drives formatted at 512 bytes/block are located in Table 7 on page 42.

Model Type	All		C4x		C2x		C1x	
Notch #	Instant.	Track	Theoretical	Typical	Theoretical	Typical	Theoretical	Typical
Average	12.07	7.91	7.17	7.13	7.13	7.10	7.06	7.03
1	12.58	8.30	7.52	7.48	7.48	7.44	7.40	7.37
2	12.58	8.30	7.52	7.48	7.48	7.44	7.40	7.37
3	12.51	7.99	7.22	7.18	7.18	7.15	7.11	7.08
4	11.96	7.74	7.02	6.99	6.99	6.95	6.92	6.89
5	11.26	7.38	6.66	6.63	6.63	6.60	6.57	6.54
6	11.05	7.07	6.41	6.38	6.38	6.35	6.31	6.28
7	10.64	6.88	6.23	6.20	6.19	6.16	6.13	6.10
8	10.29	6.64	6.03	6.00	6.00	5.97	5.94	5.91
9	10.01	6.45	5.85	5.83	5.83	5.80	5.77	5.74
10	9.59	6.15	5.55	5.53	5.53	5.50	5.48	5.45
<b>Note:</b> The values for Typical Data Sector Transfer Rates assume a typically worst case value of 3.16 errors in 10 <sup>9</sup> bits read at nominal conditions for soft error rate.								
<b>Note:</b> Contact an IBM Customer Representative for values when formatted at other block lengths.								
<b>Note:</b> "Average" values are sums of the individual notch values weighted by the number of LBAs in the associated notches.								

Table 7. Data Sector Transfer Rates. (All rates are in MB/sec)

### Data Transfer to/from SSA Link

The time required to transfer data between the SSA link and the drive's internal data buffer, that is not overlapped with the time for the Seek, Latency or Data Transfer to/from Disk.

When the drive is reading, data is transferred from the medium to its data buffer and from the buffer across the SSA link simultaneously. However, data transfer to the link from the data buffer lags transfer from the medium to the buffer by one block. At the end of the transfer from the medium, one block still has to be transferred across the link.

For a write operation, the data is normally transferred to the data buffer during the seek and latency time. In the rare case that these are both zero, the write cannot begin until one sector is transferred, and the time to do this becomes part of the overhead.

Each block of data is transferred as one or more frames on the SSA Link. Each frame requires 10 bytes of overhead and may contain up to 128 bytes of data. The time to transfer one block depends on the number of frames required. For example, a 744 byte block needs 6 frames (5 x 128 byte, 1 x 104). This adds 60 bytes of overhead making 804 bytes total. At an instantaneous transfer rate of 20MB/s, that is 40 microseconds per block (17.7MB/s sustained).

### 3.3.2 Comments

Overlap has been removed from the Command Execution Time calculations. The components of the Command Execution Times are truly additive times to the entire operation. For example,

- The Post Command Processing times are not components of the Command Execution time therefore they are not included in the calculation of environments where the re-instruct period exceeds the Post Command Processing time.

The effects of idle time functions are not included in the above examples. The 3.2.1, "Sequential" on page 40 and 3.2.2, "Random" on page 40 both define environments where the effects due to increased command overhead of Idle Time Functions upon Command Execution time are less than 0.15%.

### 3.3.2.1 Theoretical Data Sector Transfer Rate

This Rate does not account for time required for error recovery or defective sectors (the Typical Data Sector Transfer Rate described in 3.3.1, "Basic Component Descriptions" on page 40 does include those effects). Each group of cylinders with a different number of gross sectors per track is called a notch. The following shows values for notch #1 of C4x models. The "Average" values used in this specification are sums of the individual notch values weighted by the number of LBAs in the associated notches. For the other notches and block lengths use values that correspond to those notches and block lengths.

$$\begin{aligned}
 \text{Data Sector Transfer Rate} &= \\
 & \frac{\text{Bytes/cylinder}}{\text{time for 1 cyl + track skews + 1 cyl skew}} \\
 \text{Bytes/cylinder} &= \{(\text{tracks/cyl})(\text{gross sectors/track}) - \text{spares/cyl}\}(\text{user bytes/sector}) \\
 &= \{(16)(135) - 40\}(512) \\
 &= 1,085,440 \text{ Bytes/cyl} \\
 \text{time for 1 cyl of data} &= \{(\text{tracks/cyl})(\text{gross sectors/track}) - \text{spares/cyl}\}(\text{avg. sector time}) \\
 &= \{(16)(135) - 40\}(.061705) \\
 &= 130.815 \text{ msec/cyl} \\
 \text{time for track skews} &= (\text{tracks/cyl} - 1)(\text{track skew})(\text{avg. sector time}) \\
 &= (16-1)(13)(.061700) \\
 &= 12.032 \text{ msec/cyl} \\
 \text{time for 1 cyl skew} &= (\text{cylinder skew})(\text{avg. sector time}) \\
 &= (25)(.061705) \\
 &= 1.543 \text{ msec/cyl}
 \end{aligned}$$

$$\begin{aligned}
 \text{Data Sector Transfer Rate} &= \\
 & \frac{1,085,440 \text{ Bytes}}{130.815 \text{ msec} + 12.032 \text{ msec} + 1.543 \text{ msec}} \\
 &= 7.517 \text{ MB/sec (Notch \#1)}
 \end{aligned}$$

**Note:** See 2.0, "Specifications" on page 11 for the descriptions of

- tracks/cyl (trk/cyl)
- gross sectors/track (gs/trk)
- spares/cyl (b1spr/cyl and b2spr/cyl)
- user bytes/sector (ub/sct)
- gross bytes/sector (gb/sct)

See 3.5, "Skew" on page 46 for the descriptions of

- track skew (tss)
- cylinder skew (css)

Average sector times per notch can be calculated as follows:

- average sector time (ast) =

$$\frac{1 \text{ sec}}{120.045 \times \text{gs/trk}}$$

---

## 3.4 Approximating Performance for Different Environments

### 3.4.1 For Different Transfer Sizes

The primary performance change due to a change of transfer size is the Data Transfer to/from Disk parameter. See 3.3.1, "Basic Component Descriptions" on page 40 for an explanation of the calculation of this parameter.

The Command Execution Overhead may also change if the transfer size is reduced to the point where certain internal control functions can no longer be overlapped with either the SSA Link or Disk data transfer.

For example, a short read may incur up to .65ms extra overhead if the Data Ready/Reply exchange does not overlap the disk transfer.

### 3.4.2 When Read Caching is Enabled

For read commands with Read Caching Enabled Command Execution time can be approximated by deleting Seek, Latency, and Data Transfer to/from Disk components if all of the requested data is available in a cache segment (cache hit). Command Execution Overhead increases by approximately .1ms in this case as there is no overlap with seek/latency.

When some, but not all, of the requested data is available in a cache segment (partial cache hit) Data Transfer to/from Disk will be reduced but not eliminated. Seek and Latency may or may not be reduced depending upon the location of requested data not in the cache and location of the read/write heads at the time the command was received.

The contribution of the Data Transfer to/from SSA link to the Command Execution time may increase since a larger, or entire, portion of the transfer may no longer be overlapped with the components that were reduced.

### 3.4.3 When Write Caching is Enabled

For write commands with the Write Caching Enabled (WCE) Mode parameter bit set, Command Execution time can be approximated by deleting Seek, Latency, and Data Transfer to/from Disk components. The contribution of the Data Transfer to/from SSA link to the Command Execution time may increase since a larger, or entire, portion of the transfer may no longer be overlapped with the components that were reduced. The reduced times effectively are added to the Post Command Processing Time.

Command completion status is returned when data is completely stored in the buffer. The time to transfer this group of data to the disk will be added to the performance of any next command that was in the queue.

### 3.4.4 When Adaptive Caching is Enabled

The Adaptive Caching feature attempts to increase Read Cache hit ratios by monitoring workload and adjusting cache control parameters, normally determined by the using system via the Mode Parameters, with algorithms using the collected workload information.

### 3.4.5 When Read-ahead is Enabled

If read-ahead is active, the service time is affected in several ways:

- If the data requested by a read command is all in the data buffer already, the command can be serviced very quickly.
- If the beginning of the requested data is in the buffer, and the read-ahead is still in progress, data transfer

for the command can start immediately. This effectively avoids latency time for read operations sequential on a previous read.

- If the data requested by a read operation is **not** in the read-ahead buffers, there is an increase in the command overhead time due to the time spent searching the buffers. This time depends on the number of buffer segments selected by the Mode Select command.
- If read-ahead is still in progress when the next command is received and the data requested is not sequential, the drive aborts read-ahead and starts the command. The time to perform this abort increases the Command Execution Overhead by .23ms.

### 3.4.6 When No Seek is Required

For a Read command, the additional Command Execution Overhead when no seek is required is approximately .50ms. For a Write, it is approximately .70ms.

### 3.4.7 For Queued Commands

If commands are sent to the drive when it is busy performing a previous command, they can be queued. In this case, some of the command processing is performed during the previous command and the overhead for the queued command is reduced by approximately .20 milliseconds.

#### 3.4.7.1 Reordered Commands

If the Queue Algorithm Modifier Mode Parameter field is set to allow it, commands in the device command queue may be executed in a different order than they were received. Commands are reordered so that the seek portion of Command Execution time is minimized. The amount of reduction is a function of the location of the 1st requested block per command and the rate at which the commands are sent to the drive.

A Queue Algorithm Modifier Mode Parameter value of 9 enables an algorithm that gives the using system the ability to place new commands into the drive command queue execution order relative to the outstanding commands in the queue. For example, if a request is sent to the drive that the using system prioritizes such that it's completion time is more important than one or more of the outstanding commands, the using system can increase the likelihood that command is executed before those others by using a tag value greater than those outstanding commands.

#### 3.4.7.2 Back-To-Back Commands

If consecutive read/write commands access contiguous data, they can be serviced without incurring disk latency between commands.

**Note:** There is a minimum transfer length for a given environment where continuous access to the disk can not be maintained without missing a motor revolution. For Write commands with Write Caching enabled the likelihood is increased that shorter transfers can fulfill the requirements needed to maintain continuous writing to the disk.

Back-to-back Read is only enabled if Read-ahead is disabled.

### 3.4.8 Out of Order Transfers

Two bits in the SCSI Command message control out of order transfers. OOTM applies to transfers to/from the media and OOTI applies to transfers to/from the interface (SSA Link).

The benefit from setting OOTM increases as the transfer length approaches one disk revolution. This affects both reads and writes and is due to the reduction in latency.

The full benefit of out of order transfers is only achieved if OOTI is also set. Read data is transferred on the interface in the same order as it was read from the media.

## 3.5 Skew

### 3.5.1 Cylinder to Cylinder Skew

Cylinder skew is the sum of the sectors required for physically moving the heads (csms), which is a function of the formatted block length and recording density (notch #), and reassign allowance sectors (ras = 3) used to maintain optimum performance over the normal life of the drive.

**Note:** The values in the Mode Page 3 'Cylinder Skew Factor' are notch specific non-synchronized spindle mode values. The value for notch 1 is returned when the Active Notch is set to 0.

User bytes / logical block	Notch #									
	1	2	3	4	5	6	7	8	9	10
256	42	42	42	40	38	36	36	36	36	32
512	28	28	27	26	25	24	24	23	22	21
520	26	26	26	26	24	24	23	22	22	21
522	26	26	26	25	24	24	23	22	22	20
524	26	26	26	25	24	24	23	22	22	20
528	26	26	26	25	24	24	23	22	22	20
600	24	24	24	23	22	22	21	20	20	20
688	22	22	22	21	20	20	20	20	18	18
744	21	21	21	20	20	20	18	18	17	17

**Note:** Contact an IBM Customer Representative for values at other formatted block lengths.

Table 8. Optimal Cylinder Skew for several block lengths

In order to increase the likelihood that equivalent LBA's on two or more devices are located at the same relative physical position when the devices are used in a synchronized spindle mode, cylinder skew is calculated differently. The cylinder skew calculations do not take into account known defective sites. To prohibit revolutions from being missed on cylinder crossings by drives formatted while in a synchronized spindle mode, an extra allowance for 6 defects is added that is not added when optimally formatted in a non-synchronized mode.

### 3.5.2 Track to Track Skew

**Note:** The values in the SCSI Mode Page 3 'Track Skew Factor' are notch specific values. The value for notch 1 is returned when the Active Notch is set to 0.

User bytes / logical block	Notch #									
	1	2	3	4	5	6	7	8	9	10
256	20	20	20	19	19	17	17	17	17	15
512	13	13	13	12	12	11	11	10	10	10
520	12	12	12	12	11	11	10	10	10	10
522	12	12	12	12	11	11	10	10	10	9
524	12	12	12	12	11	11	10	10	10	9
528	12	12	12	12	11	11	10	10	10	9
600	11	11	11	11	10	10	10	9	9	9
688	10	10	10	10	9	9	9	9	8	8
744	9	9	9	9	9	9	8	8	8	7

**Note:** Contact an IBM Customer Representative for values at other formatted block lengths.

Table 9. Track (or Head) Skew for several block lengths

### 3.6 Idle Time Functions

The execution of various functions by the drive during idle times may result in delays of commands requested by initiators. 'Idle time' is defined as time spent by the drive not executing a command requested by a initiator. The functions performed during idle time are:

1. Servo Run Out Measurements
2. Servo Bias Measurements
3. Predictive Failure Analysis (PFA)
4. Channel Calibration
5. Save Logs and Pointers
6. Disk Sweep

The command execution time for commands received while performing idle time activities may be increased by the amount of time it takes to complete the idle time activity. The messages and data exchanged across the SSA link are not affected by idle time activities.

**Note:** Command Timeout Limits do not change due to idle time functions.

All Idle Time Functions have mechanisms to lessen performance impacts for critical response time periods of operation. And in some cases virtually eliminate those impacts from an Initiator's point of view. All Idle Time Functions will only be started if the drive has not received a SCSI command for at least 5 seconds (40 seconds for Sweep). This means that multiple SCSI commands are accepted and executed without delay if the commands are received by the drive within 5 seconds after the completion of a previous SCSI command. This mechanism has the benefit of not requiring special system software (such as issuing SCSI Rezero Unit commands at known & fixed time intervals) in order to control if and when this function executes.

**Note:** Applications which can only accommodate Idle Time Function delays at certain times, but can not guarantee a 5 second re-instruction period, may consider synchronizing idle activities to the system needs through use of the LITF bit in Mode Select Page 0, and the Rezero Unit command. Refer to the *Ultrastar XP (DFHC) SSA Models Interface Specification* for more details

Following are descriptions of the various types of idle functions, how often they execute and their duration. Duration is defined to be the maximum amount of time the activity can add to a command when no errors occur. No more than one idle function will be interleaved with each command.

Following the descriptions is a summary of the possible impacts to performance.

### 3.6.1 Servo Run Out Measurements

The drive periodically measures servo run out, the amount of wobble on each disk, to track follow more precisely.

Servo run out for all heads is measured every 60 minutes, therefore the frequency of run out measurements is dependent on the number of heads a particular model has. The drive attempts to spread the measurements evenly in time and each measurement takes 100 milliseconds. For example, a model C4x with 8 heads performs one run out measurement every  $7 \frac{1}{2}$  minutes ( $60 / 8$ ).

### 3.6.2 Servo Bias Measurements

The drive periodically measures servo bias, the amount of resistance to head movement as a function of disk radius. It also helps prevent disk lubrication migration by moving the heads over the entire disk surface.

Servo bias is measured every 12 minutes during the first hour after a power cycle, and every 60 minutes after that. The measurement takes 200 milliseconds.

### 3.6.3 Predictive Failure Analysis

*Predictive Failure Analysis* measures drive parameters and can predict if a drive failure is imminent.

Eight different PFA measurements are taken for each head. All measurements for all heads are taken over a period of 4 hours, therefore the frequency of PFA is dependent on the number of heads a particular model has. The drive attempts to spread the measurements evenly in time and each measurement takes about 80 milliseconds. For example, a C4x model with 8 heads will perform one PFA measurement every 3.7 minutes ( $240 / 8 \times 8$ ). For the last head tested for a particular measurement type (once every 1/2 hour), the data is analyzed and stored. The extra execution time for those occurrences is approximately 40 milliseconds.

This measurement/analysis feature can be disabled for critical response time periods of operation by setting the Page 0h Mode Parameter LITF = 1. The using system also has the option of forcing execution at known times by issuing the Rezero Unit command if the Page 0h Mode Parameter TCC = 1. All tests for all heads occur at those times.

**Note:** Refer to the *Ultrastar XP (DFHC) SSA Models Interface Specification* for more details about PFA, LITF, and TCC.

### 3.6.4 Channel Calibration

The drive periodically calibrates the channel to insure that the read and write circuits function optimally, thus reducing the likelihood of soft errors.

Channel calibration is done once every 4 hours and typically completes in 20 milliseconds, but may take up to 64 milliseconds per measurement.

The measurement will only be started if the drive has not received a command for at least 5 seconds. This means that multiple commands are accepted and executed without delay if the commands are received by the drive within 5 seconds after the completion of a previous command. This function also makes use of the mechanism to alter the idle detection period to limit execution for critical response time periods of operation, if needed.



### 3.6.5 Save Logs and Pointers

The drive periodically saves data in logs in the reserved area of the disks. The information is used by the drive to support various commands and for the purpose of failure analysis.

Logs are saved every 35 minutes. The amount of time it takes to update the logs varies depending on the number of errors since the last update. In most cases, updating those logs and the pointers to those logs will occur in less than 30 milliseconds.

### 3.6.6 Disk Sweep

The heads are moved to another area of the disk if the drive has not received a command for at least 40 seconds. After flying in the same spot for 9 minutes, the heads are moved to another position. Execution time is less than 1 full stroke seek.

### 3.6.7 Summary

Idle Time Function Type	Max. Frequency of Occurrence (minutes)	Duration (ms)	Mechanism to Delay/Disable
Servo Run Out	60/(trk/cyl)	100	Re-instruction Period
Servo Bias (< 1st hour)	12	200	Re-instruction Period
Servo Bias (> 1st hour)	60	200	Re-instruction Period
PFA	30/(trk/cyl)	80	Re-instruction Period / LITF
Channel Calibration	240	64	Re-instruction Period
Save Logs & Pointers	35	30	Re-instruction Period
<b>Note:</b> "Re-instruction Period" is the time between consecutive SCSI command requests.			

Table 10. Summary of Idle Time Function Performance Impacts

## 3.7 Command Timeout Limits

The 'Command Timeout Limit' is defined as the time period from when the SCSI\_command message is received by the drive until the corresponding SCSI\_status message is transmitted by the drive.

The following times are for environments where Automatic Reallocation is disabled and there are no queued commands.

**Reassignment Time:** The drive should be allowed a minimum of 45 seconds to complete a "Reassign Blocks" command.

**Format Time:** The time to complete a "Format Unit" command (with Immed bit = 0) varies by model:

- C4x** 45 minutes
- C2x** 25 minutes
- C1x** 15 minutes

Initiators should also use this time to allow format sequences initiated by "Format Unit" commands (with Immed bit = 1) to complete and place the drive in a "ready for use" state.

**Start/Stop Unit Time:** The drive should be allowed a minimum of 30 seconds to complete a "Start/Stop Unit" command (with Immed bit = 0).

Initiators should also use this time to allow start-up sequences initiated by auto start ups and "Start/Stop Unit" commands (with Immed bit = 1) to complete and place the drive in a "ready for use" state.

**Note:** A timeout of one minute or more is recommended but NOT required. The larger system timeout limit allows the system to take advantage of the extensive ERP/DRP that the drive may attempt in order to successfully complete the start-up sequence.

**Note:** A 60 second minimum is required if electronics card replacement is required as a service practice. Please contact an IBM Customer Representative for more details if required.

**Medium Access Command Time:** The timeout limit for medium access commands that transfer user data and/or non-user data should be a minimum of 30 seconds. These commands are:

- Log Select
- Log Sense
- Mode Select
- Mode Sense
- Pre-Fetch
- Read
- Read Capacity
- Read Defect Data
- Read Long
- Receive Diagnostic Results
- Release
- Reserve
- Rezero Unit
- Seek
- Send Diagnostic
- Verify
- Write
- Write and Verify
- Write Buffer
- Write Long
- Write Same

**Note:** The 30 sec limit assumes the absence of SSA link contention and user data transfers of 64 blocks or less. This time should be adjusted for anticipated SSA link contention and if longer user data transfers are requested.

**Timeout limits for other commands:** The drive should be allowed a minimum of 5 seconds to complete these commands:

- Format Unit (with Immed bit = 1)
- Inquiry
- Read Buffer
- Read Memory
- Request Sense
- Start/Stop Unit (with Immed bit = 1)
- Synchronize Cache
- Test Unit Ready

When Automatic Reallocation is enabled add 45 seconds to the timeout of the following commands: Read (6), Read (10), Write (6), Write (10), Write and Verify, and Write Same.

The command timeout for a command that is not located at the head of the command queue should be increased by the sum of command timeouts for all of the commands that are performed before it is.

## 4.0 Mechanical

### 4.1 Small Form Factor Models (CxC)

#### 4.1.1 Weight and Dimensions

	C1C & C2C Models		C4C Models	
	U.S.	S.I. Metric	U.S.	S.I. Metric
Weight	1.00 pounds	0.46 kilograms	1.80 pounds	0.82 kilograms
Height	1.00 inches	25.4 millimeters	1.63 inches	41.3 millimeters
Width	4.00 inches	101.6 millimeters	4.00 inches	101.6 millimeters
Depth	5.75 inches	146.0 millimeters	5.75 inches	146.0 millimeters

#### 4.1.2 Clearances

A minimum of 2 mm clearance should be given to the bottom surface except for a 10 mm maximum diameter area around the bottom mounting holes. Figure 11 and Figure 12 show the clearance requirements (Note 1). For proper cooling it is suggested that a clearance of 6 mm be provided under the drive and on top of the drive.

There should be 7 mm of clearance between drive's that are mounted with their top sides (see Figure 22 on page 78 for top view of drive) facing each other.

#### 4.1.3 Mounting

The drive can be mounted with any surface facing down.

The drive is available with both side and bottom mounting holes. Refer to Figure 11 to Figure 13 for the location of these mounting holes for each configuration.

The maximum allowable penetration of the mounting screws is 3.8 mm.

The torque applied to the mounting screws must be 0.8 Newton-meters ± 0.1 Newton-meters.

The recommended torque to be applied to the mounting screw is 0.8 Newton-meter ± 0.4 Newton-meter. IBM will provide technical support to users that wish to investigate higher mounting torques in their application.

**WARNING:** The drive may be sensitive to user mounting implementation due to frame distortion effects. IBM will provide technical support to assist users to overcome mounting sensitivity.

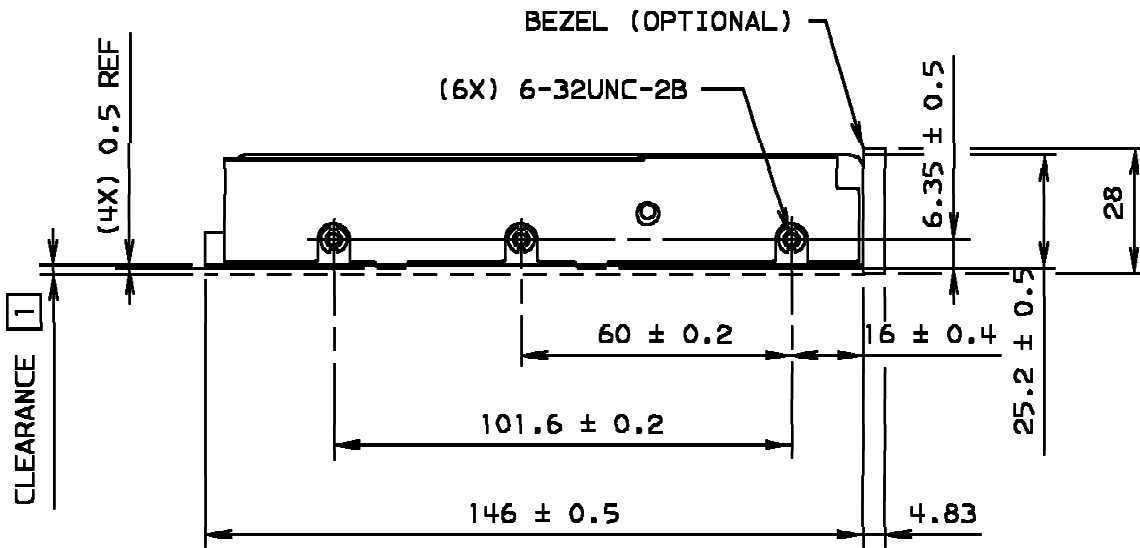

notes: 1) Bottom clearance required by 4.1.2, "Clearances."

2) Dimensions are in millimeters.

Figure 11. Location of Side Mounting Holes of C1C & C2C Models

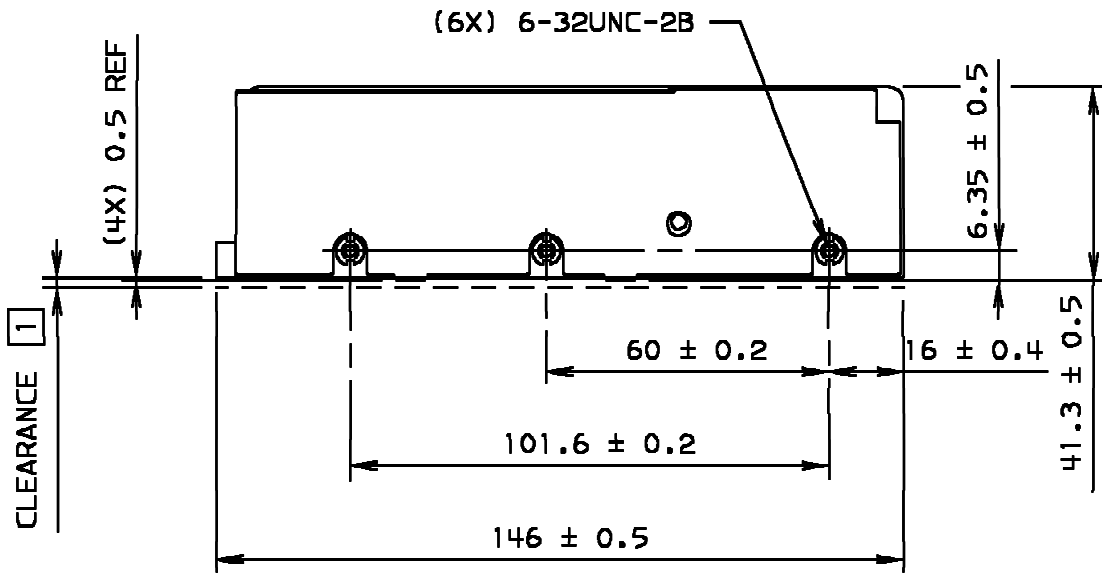

- notes:** 1) Bottom clearance required by 4.1.2, "Clearances" on page 51.
- 2) Dimensions are in millimeters.

Figure 12. Location of Side Mounting Holes of C4C Models

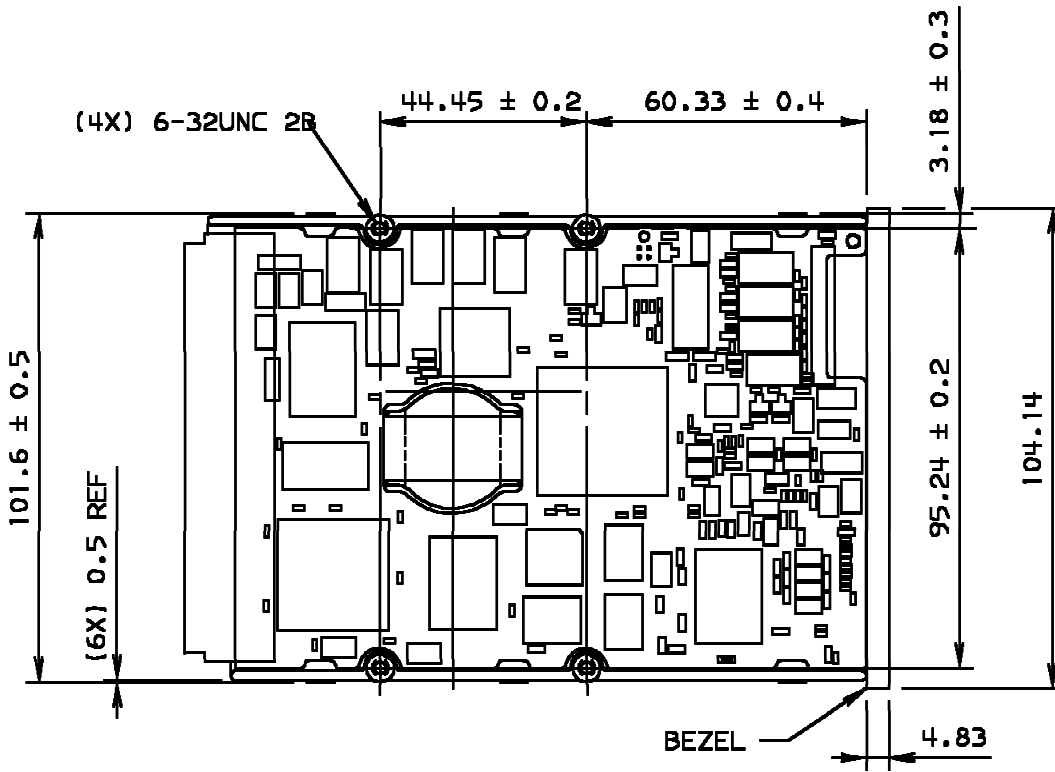

notes:

- 1) The purpose of this drawing is to show the bottom hole pattern.
- 2) Dimensions are in millimeters.

Figure 13. Location of Bottom Mounting Holes of CxC Models

#### 4.1.4 Unitized Connector Locations

The Unitized connector is located on the left side of the top view (bottom drawing) as shown in Figure 14 on page 56. The jumper connector is located on the right side of the top view (bottom drawing) as shown in Figure 14 on page 56. This jumper connector is referred to as Front Jumper because of its front location. It is reserved for IBM Engineering used only.

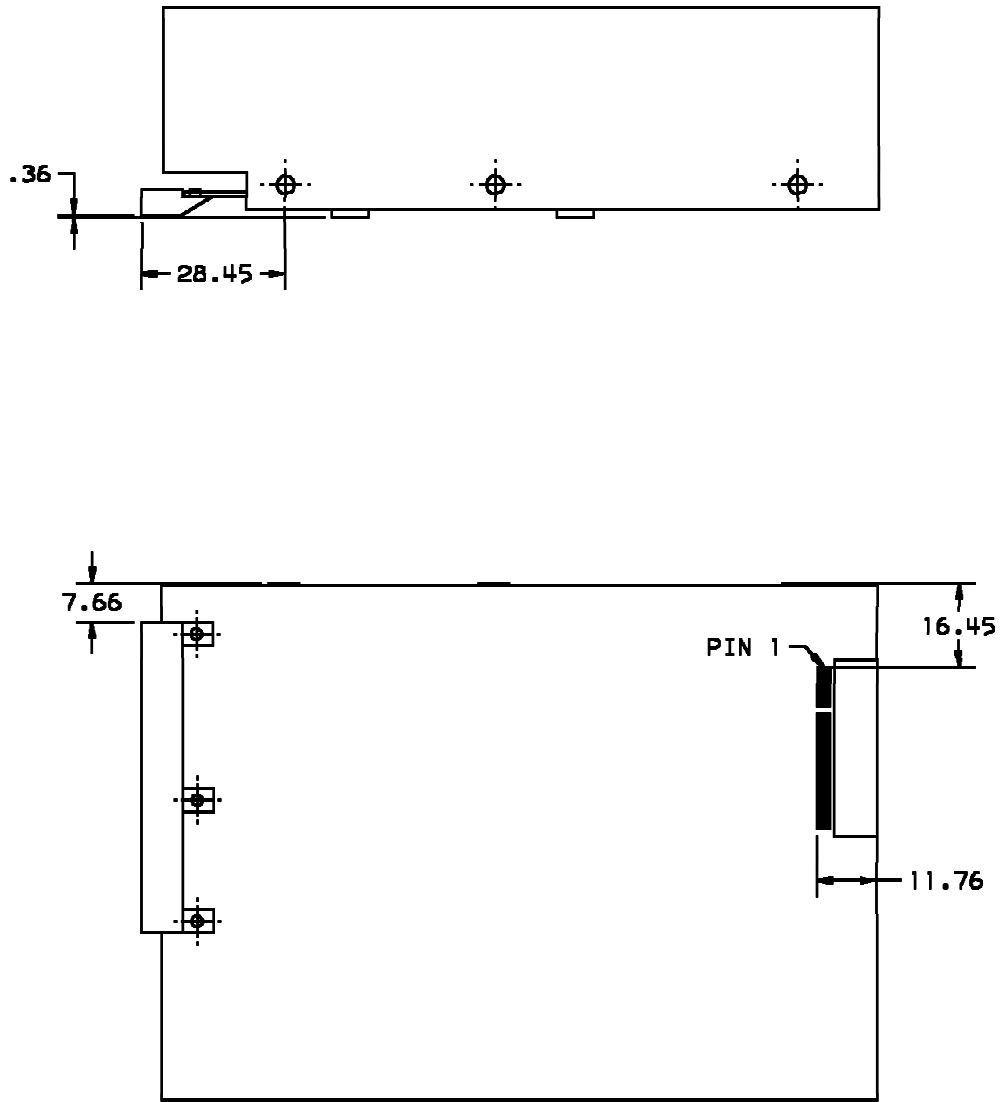

---

Figure 14. Electrical connectors (rear and top view) -- CxC Models.



## 4.2 Carrier Models (CxB)

The carrier model assemblies include the disk drive, drawer mounting hardware (rails, latching mechanism, and connector), and DC/DC power converter.

### 4.2.1 Weight and Dimensions

	C1B & C2B Models		C4B Models	
	U.S.	S.I. Metric	U.S.	S.I. Metric
Weight	2.00 pounds	0.92 kilograms	2.80 pounds	1.288 kilograms
Height	1.75 inches	44.5 millimeters	1.75 inches	44.5 millimeters
Width	4.26 inches	108.3 millimeters	4.26 inches	108.3 millimeters
Depth	10.72 inches	272.3 millimeters	10.72 inches	272.3 millimeters

Refer to Figure 15 on page 58 for detailed dimensions.

### 4.2.2 Clearances

For proper cooling, a clearance of 6 millimeters should be provided above and below the carrier surfaces. Adequate airflow is needed in order to meet the operating specifications. Maximum temperatures are specified for critical drive components in Table 15 on page 78.

### 4.2.3 Mounting

The drive can be mounted with any surface facing down.

The carrier is designed to be plugged into an auto-docking assembly. The auto-docking assembly contains an electrical receptacle that provides connections for DC power, SSA interface signals, and fault sensing and reporting signals (see 5.2, "Carrier Connector" on page 64). The carrier design allows for positive retention of the carrier in all axes when plugged into the auto-docking assembly. In addition, the carrier retention provides a force to bottom out the carrier auto-docking connector into the auto-docking assembly and maintain a force of 5 pounds minimum, 40 pounds maximum.

The mating connector should contain two guide pins to align the carrier receptacle during seating. These guide pins are BERG part number 77693-014 (IBM part number 72G0343) or AMP equivalent part number 1-532808-1 (IBM part number 19G6789). The guide pin length should be 26.04 millimeters while the thread depth depends upon the thickness of the circuit board the connector is mounted to. The guide pins should be tied to the docking assembly frame ground.

**Note:** The connector pins must be lubricated to insure seating of the carrier into the auto-docking assembly. The type of lubricant recommended is Stauffer CL-920 or equivalent.

**WARNING:** The drive may be sensitive to user mounting implementation due to frame distortion effects. IBM will provide technical support to assist users to overcome mounting sensitivity.

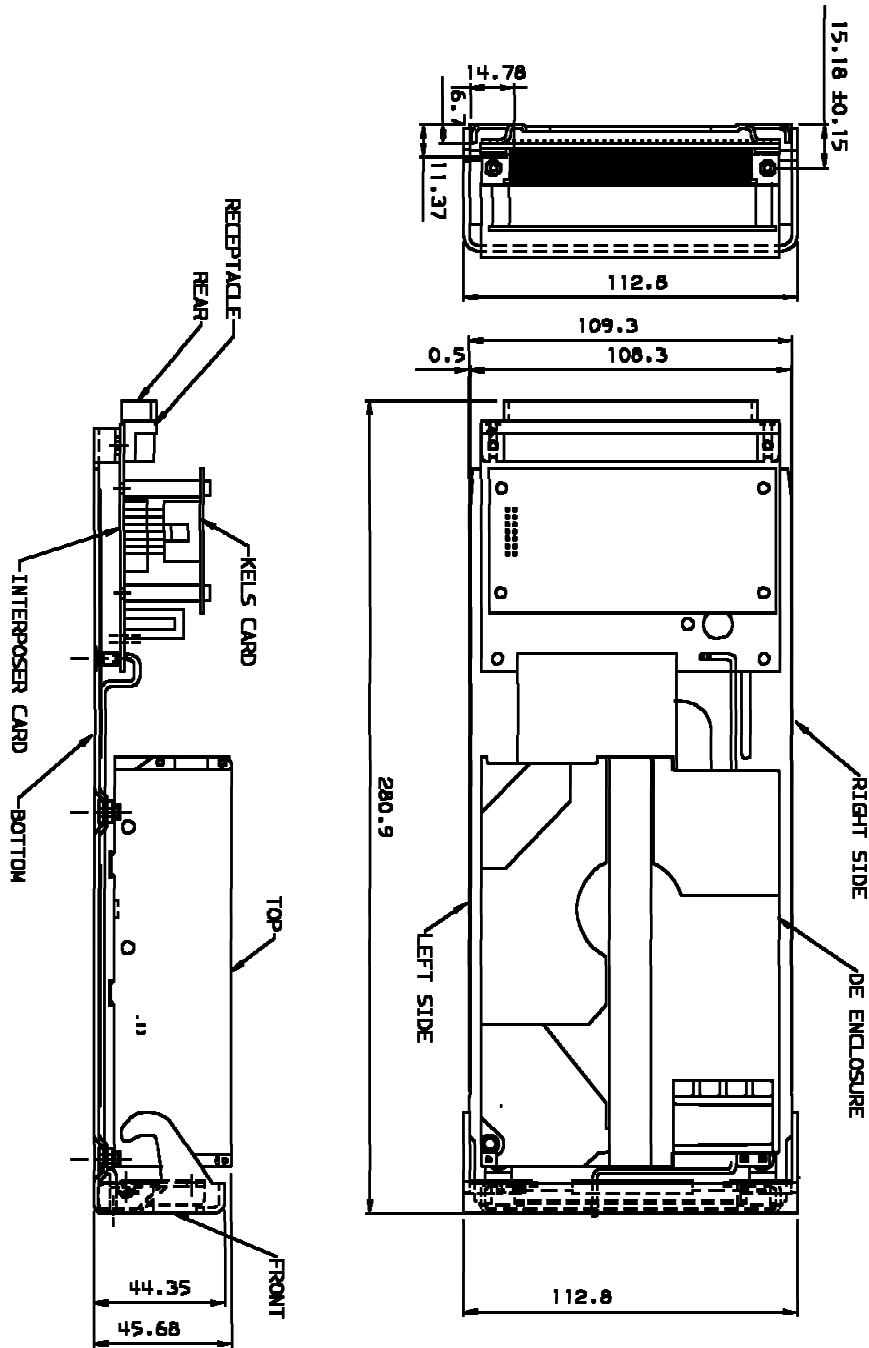

**Note:** Dimensions are in millimeters.

Figure 15. Dimensions — CxB Models

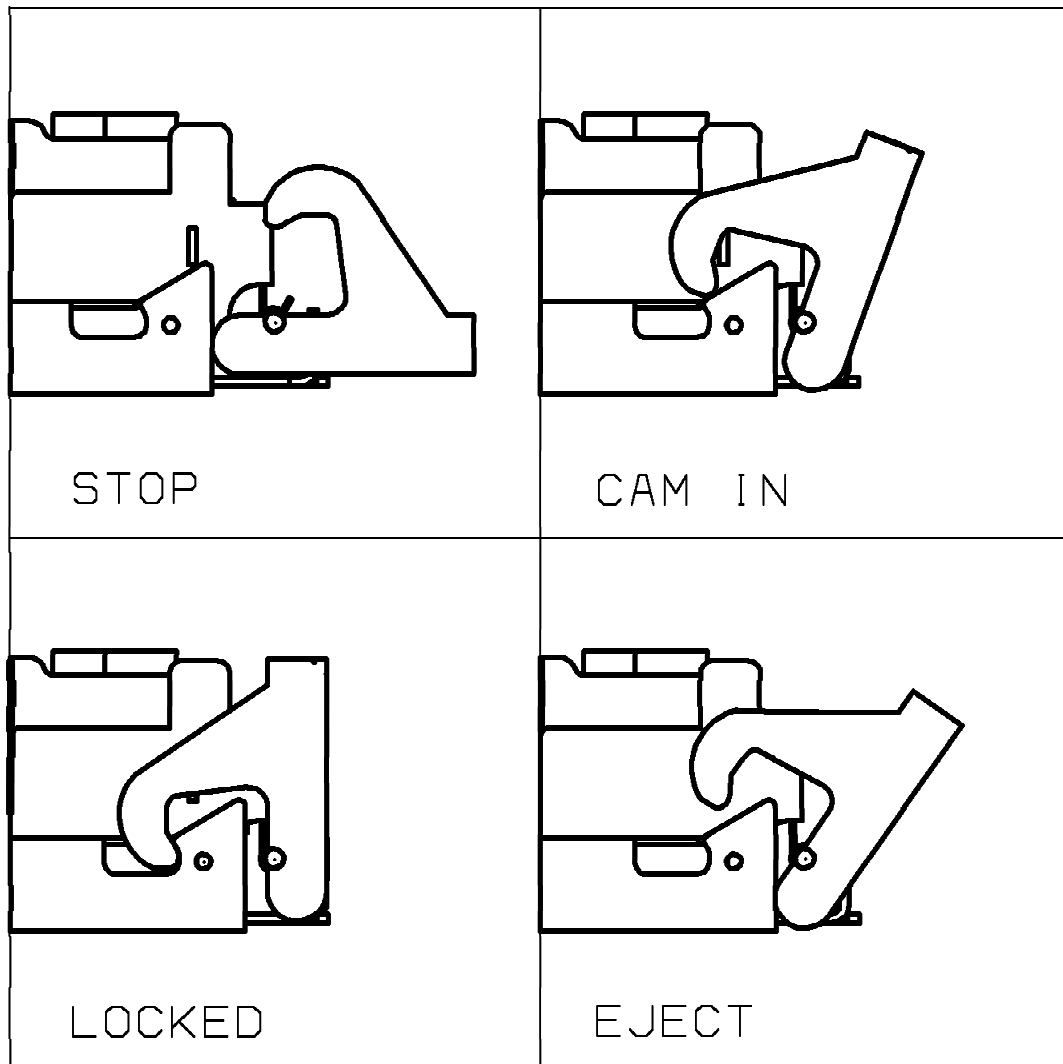

Figure 16. Handle Docking and Ejection System

The handle on the carrier is used for insertion into and extraction from the drawer. It also provides enough force to ensure seating of the carrier electrical receptacle with the mating connector. Referring to Figure 16, with the handle in the STOP or open position, a carrier inserted into the auto-docking assembly will have the connector guide pins inserted into the carrier receptacle but the connector pins will not be making contact with the carrier receptacle. Moving the carrier handle to the CAM IN position and eventually to the LOCKED position sets the auto-docking connector with the carrier receptacle and holds the carrier in all the mounting positions listed above. Moving the handle from the LOCKED position to the EJECT position provides leverage via the cam surface on the handle acting against the side rails to separate the connector pins from the receptacle.

## 4.2.4 Auto-docking Assembly Side Rails

IBM supplied side rails that can be used for the auto-docking assembly are shown in Figure 17 on page 61 along with mounting location information. Refer to the figure for the following notes:

**Note 1:** With the side rails mounted within the given tolerances, there will be a nominal 1.5 millimeter interference between the handle and side rail to provide positive retention of the carrier and the handle.

**Note 2:** The IBM part number of the auto-docking side rails is 36G6422.

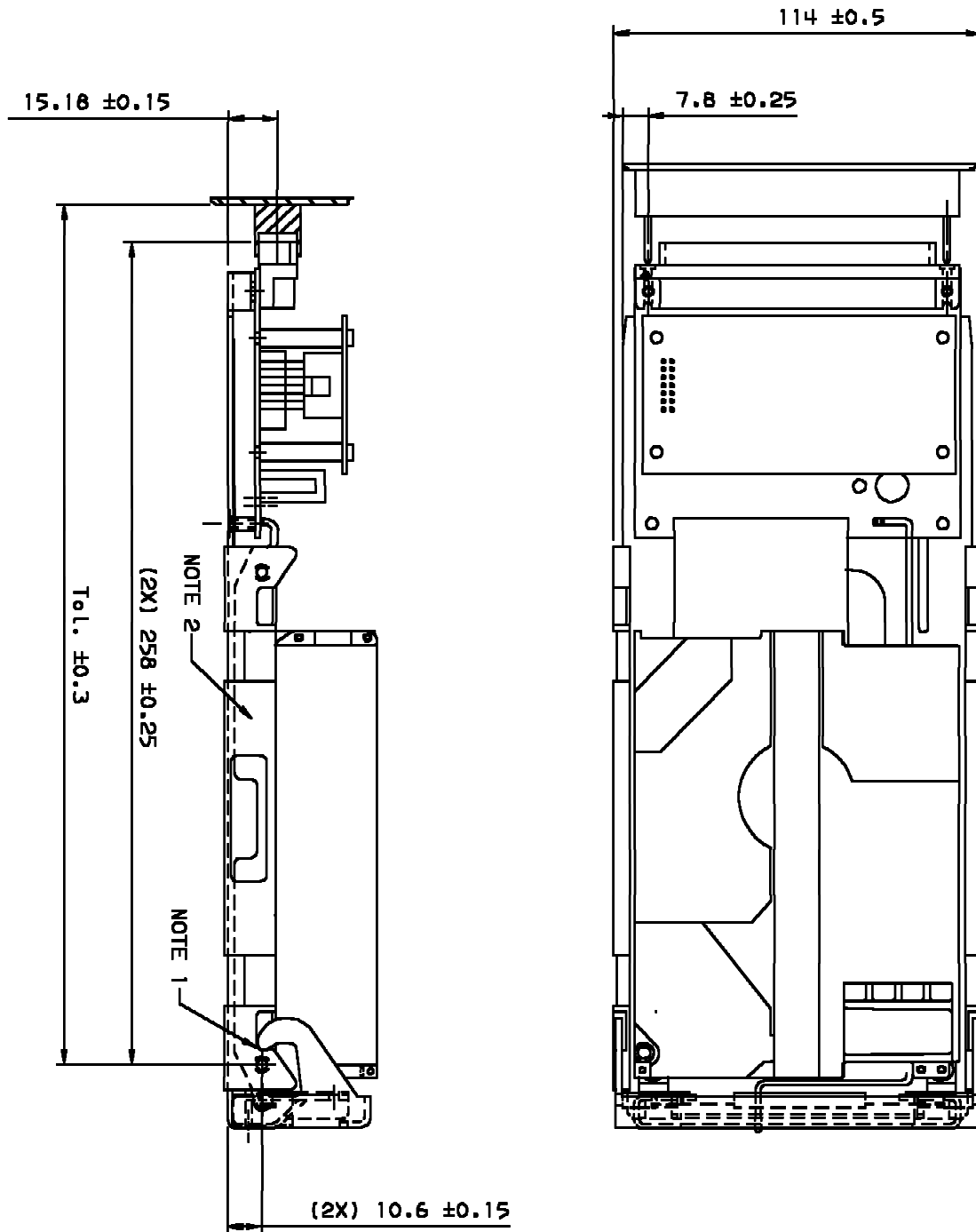
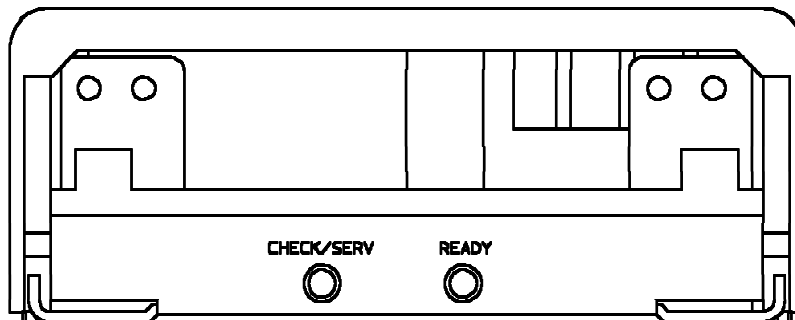

Figure 17. Side Rail Positioning

## 4.2.5 Electrical Connector and Indicator Locations

The HPC electrical connectors are located as shown in Figure 15 on page 58. The indicators (LEDs) are located as shown in Figure 18 on page 62.

---



---

Figure 18. LED Locations (front view) —CxB Models.

## 5.0 Electrical Interface

### 5.1 SSA Unitized Connector

Electrical connections for CxC models are provided by a single connector mounted on the rear of the drive (see Figure 14 on page 56). Connections are provided for two SSA ports, fault sensors and indicators, option customization, and power. Refer to Figure 19 and Table 11 on page 64 for contact assignments.

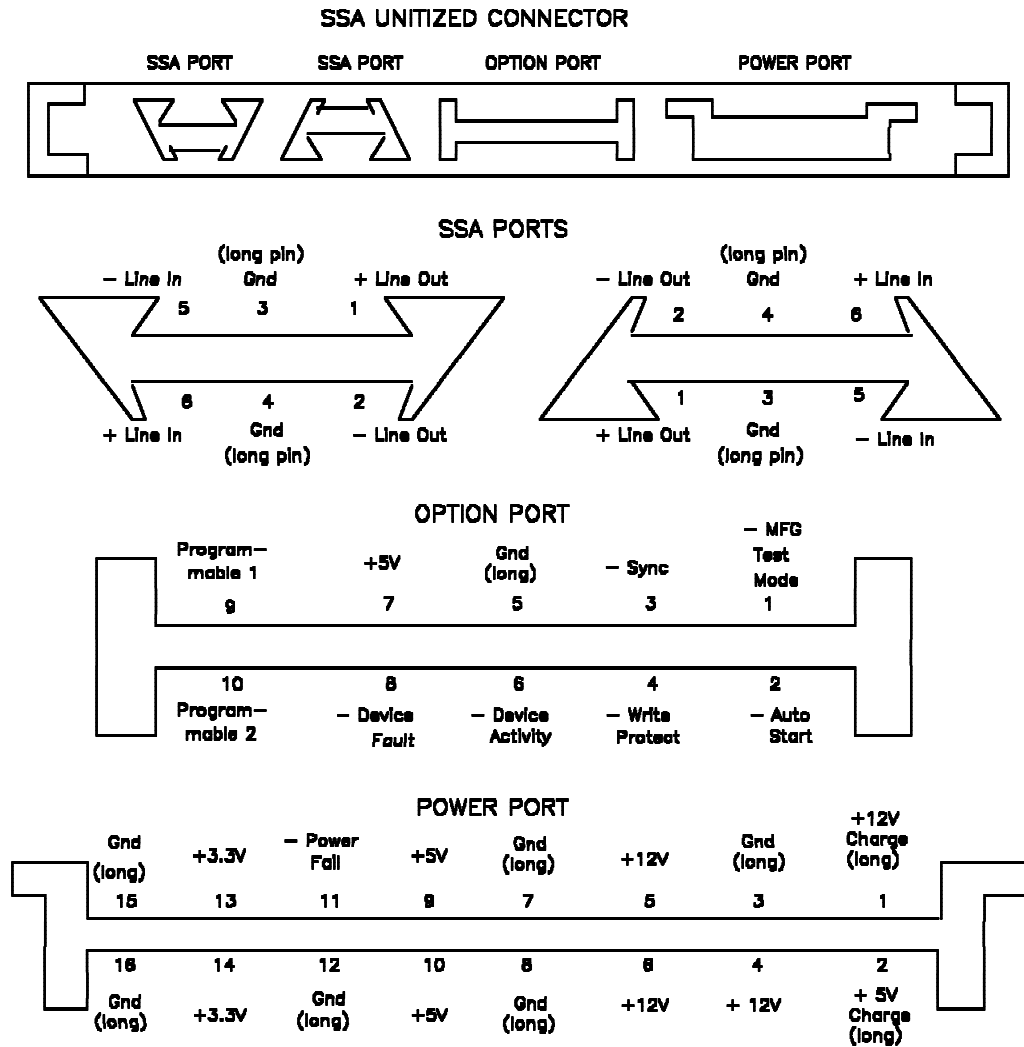

Figure 19. Unitized Connector (looking in the file at the connector end)

Pin	SSA PORT	SSA PORT	OPTION PORT	POWER PORT
1	+ Line Out	+ Line Out	- MTM	+ 12V Charge (long)
2	- Line Out	- Line Out	- Auto Start	+ 5V Charge (long)
3	Gnd (long)	Gnd (long)	- Sync	Gnd (long)
4	Gnd (long)	Gnd (long)	- Write Protect	+ 12V
5	- Line In	- Line In	Gnd (long)	+ 12V
6	+ Line In	+ Line In	- Device Activity	+ 12V
7	N/A	N/A	+ 5V	Gnd (long)
8	N/A	N/A	- Device Fault	Gnd (long)
9	N/A	N/A	Programmable 1	+ 5V
10	N/A	N/A	Programmable 2	+ 5V
11	N/A	N/A	N/A	- Power Fail
12	N/A	N/A	N/A	GND (long)
13	N/A	N/A	N/A	+ 3.3V
14	N/A	N/A	N/A	+ 3.3V
15	N/A	N/A	N/A	Gnd (long)
16	N/A	N/A	N/A	Gnd (long)

Table 11. Electrical Connector Contact Assignments —CxC Models

## 5.2 Carrier Connector

Electrical connections for CxB models are provided by a single 128 pin connector mounted on the rear of the drive (see Figure 15 on page 58 for location). Connections are provided for two SSA ports, fault sensors and indicators, and power. The receptacle used is a 4x32, female contact, BERG HPC connector, IBM part number 99F9429. Refer to Figure 20 and Table 12 on page 65 for contact assignments.

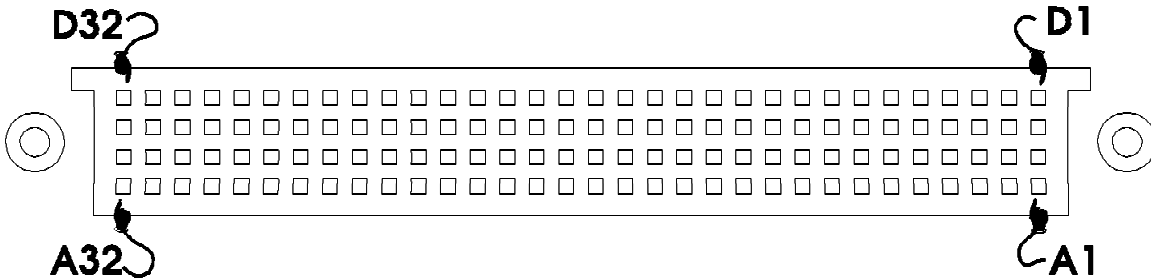

Figure 20. Carrier Interface Receptacle



Row	A	B	C	D
1	n/c	n/c	n/c	n/c
2	n/c	n/c	n/c	n/c
3	n/c	n/c	n/c	n/c
4	n/c	n/c	n/c	n/c
5	n/c	n/c	n/c	n/c
6	n/c	n/c	n/c	n/c
7	n/c	n/c	n/c	Device Fault (*)
8	+38V Source A	+38V Source A	+38V Source A	+38V Source A
9	+38V Source A	+38V Source A	+38V Source A	+38V Source A
10	Ground	Ground	Ground	Ground
11	Ground	Ground	Ground	Ground
12	+38V Source B	+38V Source B	+38V Source B	+38V Source B
13	+38V Source B	+38V Source B	+38V Source B	+38V Source B
14	n/c	n/c	n/c	n/c
15	n/c	n/c	n/c	n/c
16	n/c	n/c	n/c	n/c
17	Shield	Shield	Shield	Shield
18	+ Out 1	+ Out 1	+ In 2	+ In 2
19	- Out 1	- Out 1	- In 2	- In 2
20	Shield	Shield	Shield	Shield
21	+ In 1	+ In 1	+ Out 2	+ Out 2
22	- In 1	- In 1	- Out 2	- Out 2
23	Shield	Shield	Shield	Shield
24	n/c	n/c	n/c	n/c
25	n/c	n/c	n/c	n/c
26	n/c	n/c	n/c	n/c
27	n/c	n/c	n/c	n/c
28	n/c	n/c	n/c	n/c
29	n/c	n/c	n/c	n/c
30	n/c	n/c	n/c	n/c
31	n/c	n/c	n/c	n/c
32	n/c	n/c	n/c	n/c
<b>Note:</b>				
<ul style="list-style-type: none"> <li>• "n/c" means "no connection" (not used).</li> <li>• (*) means pin is reserved for this function but model CxB does not provide connection to support it.</li> </ul>				

Table 12. Electrical Connector Contact Assignments —CxB Models

---

## 5.3 SSA Link Cable

The SSA link cable must meet the specifications described in the Electrical Specifications section of *Serial Storage Architecture SSA-PH (Transport Layer), X3T10.1/94-015 rev 01*.

---

## 5.4 SSA Link Electrical Characteristics

The drive SSA link line driver, line receiver, and line receiver termination are fully compliant with the specifications described in the Electrical Specifications section of *Serial Storage Architecture SSA-PH (Transport Layer), X3T10.1/94-015 rev 01*.

---

## 5.5 Option Pins and Indicators

**Ultrastar XP SSA** drives contain option pins and/or indicators used to sense and report fault conditions, and to enable certain features of the drive. The electrical characteristics and requirements of these pins are fully compliant with the specifications described in the Electrical Specification section of *Serial Storage Architecture SSA-PH (Transport Layer), X3T10.1/989D rev 01*. The existence and definition of these pins are model dependent. Refer to Figure 14 on page 56 and Figure 18 on page 62 for locations of pins and LEDs on the front of the drive. Refer to Table 11 on page 64 and Table 12 on page 65 for locations of pins on the rear of the drive.

### 5.5.1 - Manufacturing Test Mode (Option Port Pin 1)

A low active input pin, that when active (pulled below .8V) makes pins 2, 3, 4, 6, 8, 9 and 10 available to be redefined. Pins 5 and 7 must remain Ground and +5 V respectively. One possible purpose for this pin is to allow a manufacturing tester to redefine the option pins to whatever functions it desires, while allowing the shipped product to return to the standard definitions in the customers environment. All models (Cx C and Cx B) reserve this pin but it is not connected to any internal logic.

### 5.5.2 - Auto Start Pin (Option Port Pin 2)

A low active input pin, that when active (pulled below 0.8 V) on Cx C model causes the drive motor to spin up and become ready for media access operations after power is applied without the need to receive a Start/Stop Unit command. When inactive (pulled above 2.0 V), the drive motor shall not spin up until after the receipt of a Start/Stop Unit command. The signal is to be sampled by the device at power on, or hard reset or soft reset conditions. Refer to the "Option Pins" section of the *Ultrastar XP (DFHC) SSA Models Interface Specification* for a detailed functional description of operations associated with this pin.

This pin is not accessible on Cx B models.

### 5.5.3 - Sync Pin (Option Port Pin 3)

The **Sync** input/output pin on Cx C model can be used for synchronizing among devices. The synchronization is achieved by having one device uses this pin as output to transmit one sync character once per its spindle revolution. The other node may use this pin as an input and synchronize their spindle revolution position to match the Sync signal. The SSA network provide Sync character over SSA link, but this option pin allows synchronization across multiple SSA networks, or allow tighter latency of the Sync pulse. Refer to Figure 21 on page 70 for examples of Synchronization connection.

The width, period, and tolerance of the negative active Sync pulse is manufacturer dependent, and thus synchronization across different manufacturers or even different product lines of the same manufacturer is not guaranteed. The Sync pin usage is controlled by mode pages within the mode select command.

This pin is not accessible on CxB model.

#### 5.5.4 - Write Protect (Option Port Pin 4)

a low active input pin, that when active (pulled below 0.8 V), the drive will prohibit commands that alter the customer data area portion of the the media from being performed. The state of this pin is monitored on a per command basis. Refer to "Option pins" section of the *Ultrastar XP (DFHC) SSA Models Interface Specification* for a detailed functional description of this pin.

This pin is not accessible on CxB models.

#### 5.5.5 - Ground long (Option Port Pin 5)

The **Ground** long output pin on CxC and CxB models shall be capable of syncing 1.0 Amp of current. This pin is longer than any others in the option block to allow for the ground to mate first or last in a hot-plug or hot-unplug situation.

#### 5.5.6 - Device Activity Pin/Indicator (Option Port Pin 6)

A low active LED output pin on CxC models can be used to drive an external Light Emitting Diode. CxB models have an integrated Green LED. Refer to the "Option Pins" section of the *Ultrastar XP (DFHC) SSA Models Interface Specification* for a detailed functional description of this pin/LED.

CxC models provide up to 24 mA of TTL level LED sink current capability. Current limiting for the LED is provided on the electronics card. The anode may be tied to the +5V power source (provided on the the unitized connector). The LED Cathode is then connected to the **Device Activity** pin to complete the circuit.

#### 5.5.7 + 5V (Option Port Pin 7)

The + 5V output pin on CxC and CxB models shall supply up to 1.0 Amp of current limited + 5 V (+/- 10%), as long as power is supplied to the device.

#### 5.5.8 - Device Fault Pin/Indicator (Option Port Pin 8)

The **Device Fault** pin on CxC models can be used to drive an external Light Emitting Diode. CxB models have an integrated Amber LED. Refer to the "Option Pins" section of the *Ultrastar XP (DFHC) SSA Models Interface Specification* for a detailed functional description of this pin/LED.

CxC models provide up to 24 mA of TTL level LED sink current capability. Current limiting for the LED is provided on the electronics card. The anode may be tied to the +5V power source (provided on the the unitized connector). The LED Cathode is then connected to the **Device Fault** pin to complete the circuit.

### 5.5.9 Programmable pin 1 (Option Port Pin 9)

This pin can be used by a manufacturer for what ever purposes it desires within the specified definition, electrical characteristic and the availability of microcode. This pin is completely controlled by microcode. Refer to the "Option Pins" section of the *Ultrastar XP (DFHC) SSA Models Interface Specification* for a detailed functional description of this pin.

This pins is not accessible externally on CxB models.

### 5.5.10 Programmable pin 2 (Option Port Pin 10)

This pin is reserved and it is not connected to any internal logic.

This pins is not accessible externally on CxB models.

### 5.5.11 - Early Power Off Warning or Power Fail (Power Port Pin 11)

The *Early Power Off Warning* input pin on CxC models can be used to indicate to the drive that a power loss will occur by pulling this signal to ground. The input must provide a minimum of 6 milliseconds warning before power falls below operating specifications in order for the drive to stop its activities and handle the fault. Refer to the "Option Pins" section of the *Ultrastar XP (DFHC) SSA Models Interface Specification* for a detailed functional description of the fault handling associated with this pin..

This pin is not accessible on CxB models.

### 5.5.12 12V Charge and 5V Charge (Power Port pin 1 and 2)

These pins are longer than the others. They help to reduce current spikes during hot plug. Each pin require a resistor (not in the drive) in series between the power source and the drive connector. This allows for more controlled current draw as prior to other voltage pins. It is up to the subsystem to determine the proper resistance to add to these pins to meet the +/- 10% voltage drop limitations and the current draw limitation of the connector.

These pins are not accessible on CxB models

---

## 5.6 Front Jumper Connector

All models contain a jumper block (refer to Figure 14 on page 56) that is reserved for IBM Engineering use only.

## 5.7 Spindle Synchronization

### 5.7.1 Synchronization overview

Spindle synchronization of drives is achieved by one node transmitting a special Sync character or a Sync pulse once per every revolution of its drive. The transmitting is done either on SSA Link (sending Sync character) or on a hard-wire (Sending Sync pulse) that connects all the drives via the SSA Option Port 'Sync' pin. The synchronization mode is controlled by the RPL field of the Mode Select Page 04h parameter (see *Ultrastar XP (DFHC) SSA Models Interface Specification* for more details). The drive can operate in one of three modes:

### 5.7.2 Synchronization Mode

Mode	Operation
<b>No Sync</b>	Spindle synchronization is disabled.
<b>Slave Sync</b>	Spindle synchronization is attempted by synchronizing the spindle motor to the Sync special character on SSA link (or the Sync pulse on Sync hard-wire) that is driven by another node.
<b>Master Sync</b>	Spindle synchronization is not attempted by this device. It generates a Sync special character via SSA link (or a Sync pulse via a hard-wire) once per its spindle revolution.
<b>Master Sync Control</b>	Master Sync Control is not supported.

### 5.7.3 Synchronization time

It will take 6 seconds to synchronize the Slave drive to the Master drive. While the Slave drive is synchronizing to these characters, it is not able to read or write data. Once synchronized the drive will maintain  $\pm 20$  microseconds synchronization tolerance.

When operating in Slave Sync mode, the drive must receive the Spindle Sync special characters at a period of 8.333 milliseconds with a tolerance of  $\pm .025\%$  (2.08 microseconds).

### 5.7.4 Synchronization with Offset

The **Rotational Offset** value is the amount of rotational skew that the Target uses when synchronized. The rotational skew is applied in the retarded direction (lagging the synchronized spindle master control). The value in the field is the numerator of a fractional multiplier that has 256 as its denominator (e.g., a value of 128 indicates a one-half revolution skew). A value of 00h indicates that rotational offset is not used. The rotational offset is only used when the Drive is running in the Slave Sync RPL mode.

### 5.7.5 Synchronization Route

#### 5.7.5.1 Over SSA Link

Spindle Sync special characters are forwarded from one SSA link to the other with a delay of 350 nanoseconds with a tolerance of  $\pm 50$  nanoseconds. This delay can be increased by 50 nanoseconds when the drive is sending the second of a double character sequence (RR or ACK) and by 50 nanoseconds when sending a SAT or SAT' character.

The spindle synchronization timing requirements are met in a string composed of **Ultrastar XP SSA** drives when there are no more than seventeen drives between the one operating in Master Sync mode and the furthest drive operating in Slave Sync mode.

### 5.7.5.2 Over Sync Hard-wire

There will be a single wire that connects all the drives together through the SSA Option Port pin 3 (- Sync pin). One of these drives will be a Master drive. Two potential configurations of this hard-wire connection are shown in the following figures:

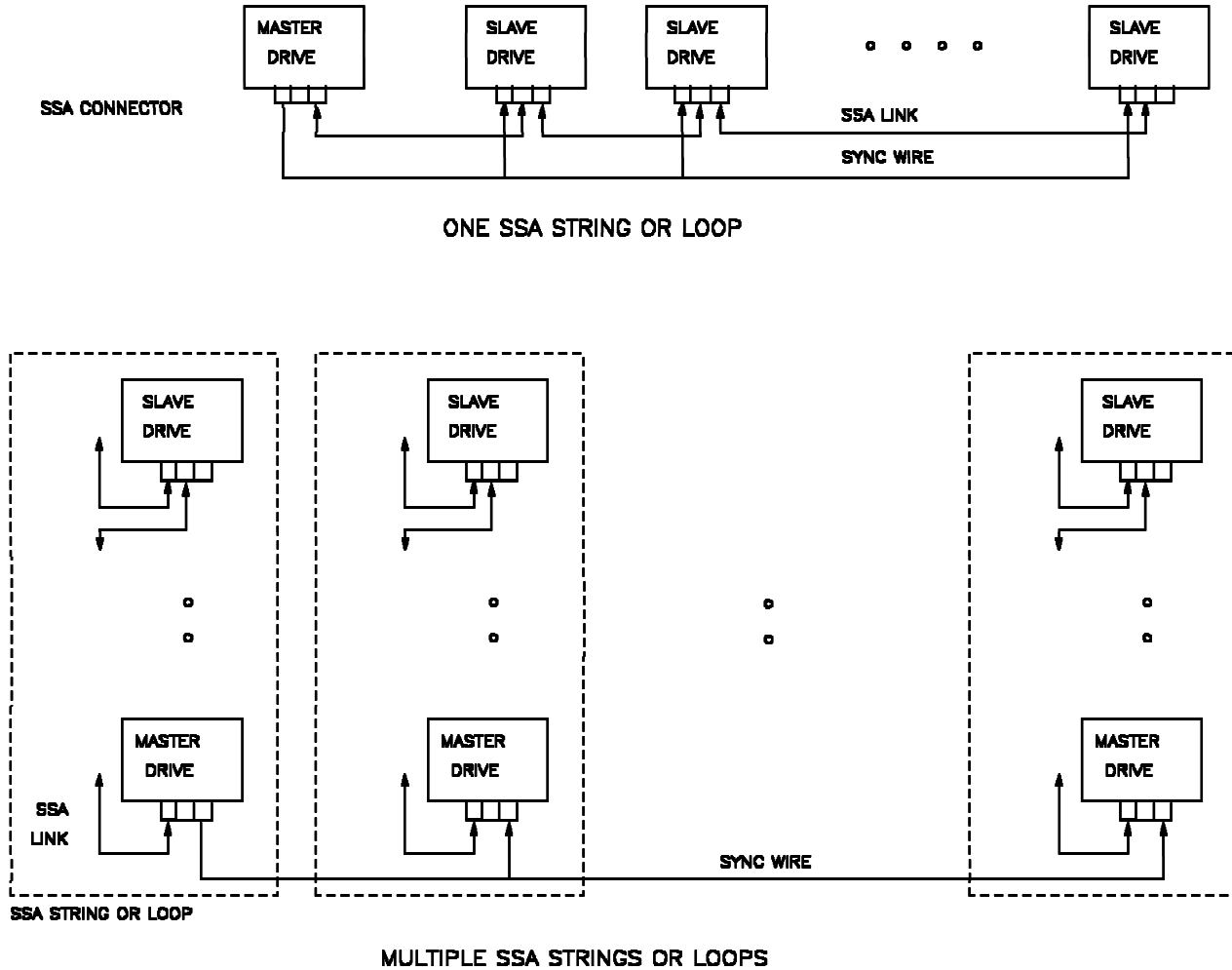

Figure 21. Two examples of Daisy-Chain Connection of Synchronization

- Termination

Bus termination of the - SYNC signals is internal to the drive. This signal has a 5.1K ohm pulled-up to the +5 volt supply. A maximum of 30 drives can have their - SYNC line daisy chained together. Violating this could damage the Master drive line driver on the - SYNC line

It is the using system's responsibility to provide the cable to connect the - SYNC line where needed, of the synchronized drives.

- Bus Characteristics

- maximum Bus length = 6 meters
- 2 micro-second negative active pulse (when sourced by drive)
- minimum of 1 micro-second negative active pulse when externally sourced
- 0.8 volts = valid low input
- 2.2 volts = valid high input
- 0.4 volts = low output
- Vcc volts = High output
- 30 milli-amps = maximum output low level sink current

The driver used for these two signal lines is a Open Drain buffer.





---

## 6.0 Reliability

**Note:** The reliability projections are based on the conditions stated below. All of the SSA models will meet the projections as long as reliability operating conditions are not exceeded.

---

### 6.1 Error Detection

**Error reporting  $\geq$  99%** All detected errors excluding interface and BATs #1 (Basic Assurance Test) errors

**Error detection  $\geq$  99%**

**FRU isolation = 100%** To the device when the "Recommended Initiator Error Recovery Procedures" in the *Ultrastar XP (DFHC) SSA Models Interface Specification* are followed.

No isolation to sub-assemblies within the device are specified.

---

### 6.2 Data Reliability

**Probability of not recovering data** 10 in  $10^{15}$  bits read

**Recoverable read errors** 10 in  $10^{13}$  bits read (measured at nominal DC conditions and room environment with default error recovery —QPE\*\*)

**Probability of miscorrecting unrecoverable data**

**Note:** Eighteen bytes of ECC and two bytes of LRC are provided for each data block.

---

### 6.3 Seek Error Rate

The drives are designed to have less than 10 errors in 10,000,000 seeks. In the field, a seek error rate of 40 in 100,000 seeks will trip PFA (Predictive Failure Analysis) error.

The drives are designed to achieve Soft Seek Error rate of 1 error in 100,000,000 seeks.

---

### 6.4 Power On Hours Examples:

**Maximum power on hours (with minimum power on/off cycles)**

43,800 hours for life based on:

- 5 Power on/off cycles per month

- 730 power on hours per month

**Nominal power on hours (with nominal power on/off cycles)**

30,000 hours for life based on:

---

\*\* Refer to *Ultrastar XP (DFHC) SSA Models Interface Specification* for the definition of QPE (Qualify Post Error).

- 25 Power on/off cycles per month
- 500 power on hours per month

---

## 6.5 Power on/off cycles

Maximum on/off cycles 1080/ year

---

## 6.6 Useful Life

Product Life 5 Years

Useful life is the length of time prior to the point at which product degradation begins to occur. The specification for the useful life calculation is the same as that for the \*MTBF specification.

## 6.7 \*Mean Time Between Failure (\*MTBF)

The mean time to failure target is 1,000,000 device hours per fail (3.0% CDF) based on the following assumptions:

- 6000 power on hours per year (500 power on hours per month times 12 months)
- 300 average on/off cycles per year (25 power cycles per month times 12 months)
- Seeking/Reading/Writing is assumed to be 20% of power on hours (Approximately 10 read/write operations per second)
- Operating at or below the Reliability temperature specifications (See Table 15 on page 78) and nominal voltages (See 2.2, “Power Requirements by Model” on page 15)

**Note:** \*MTBF - is a measure of the failure characteristics over **total product life**. \*MTBF includes normal integration induced, installation, early life (latent), and intrinsic failures. \*MTBF is predicated on supplier qualification, product design verification test, and field performance data.

### 6.7.1 Sample Failure Rate Projections

The following tables are for reference only. The tables contain failure rate projections for a given set of user conditions. Similar projections will be provided, upon request, for each user specific power on hour and power cycles per month condition. Contact your IBM customer representative for a customized projection.

Application	Electronics only - (RA/MM)				
	1st 30 days	1st 60 days	1st 90 days	30 day average over life	CDF
500POH/MM	0.00120	0.0010	0.00096	0.00036	2.1%
730POH/MM	0.00160	0.00140	0.00125	0.00047	2.8%

Table 13. Projected failure rates for the electronics only.

Application	Electronics and HDA - (RA/MM)				
	1st 30 days	1st 60 days	1st 90 days	30 day average over life	CDF
500POH/MM	0.00150	0.00130	0.00120	0.00050	3.0%
730POH/MM	0.00200	0.00170	0.00160	0.00070	4.1%

Table 14. Projected failure rates for the entire drive. (Electronics and HDA).

## 6.8 SPQL (Shipped product quality level)

Targets	LA vintage .25%	Ultimate (13th month) .10%
---------	--------------------	-------------------------------

## 6.9 Install Defect Free

**Install Defect Free percentage** 99.99 percent

---

## 6.10 Periodic Maintenance

None required

---

## 6.11 ESD Protection

The **Ultrastar XP SSA** disk drives contain electrical components sensitive to damage due to electrostatic discharge (ESD). Proper ESD procedures must be followed during handling, installation, and removal. This includes the use of ESD wrist straps and ESD protective shipping containers.

---

## 6.12 Connector Insertion Cycles

Live insertion and removal of the electrical connector causes pitting on the connector terminals. Because of this the number of live insertion and removal cycles must be limited.

**Maximum Insertion/Removal Cycles (for hot and normal insertion) 25**

## 7.0 Operating Limits

The IBM Corporate specifications and bulletins, such as C-S 1-9700-000 in the contaminants section, that are referenced in this document are available for review. (Please contact your IBM Customer)

### 7.1 Environmental

#### Temperature

<b>Operating Ambient</b>	41 to 131°F (5 to 55°C)
<b>Operating Casting Temperature</b>	41 to 158°F (5 to 70°C)
<b>Storage</b>	34 to 149°F (1 to 65°C) See Note
<b>Shipping</b>	-40 to 149°F (-40 to 65°C)

#### Temperature Gradient

<b>Operating</b>	36°F (20°C) per hour
<b>Shipping and storage</b>	below condensation

#### Humidity

<b>Operating</b>	5% to 90% noncondensing
<b>Storage</b>	5% to 95% noncondensing
<b>Shipping</b>	5% to 100% (Applies at the packaged level)

#### Wet Bulb Temperature

<b>Operating</b>	80°F (26.7°C) maximum
<b>Shipping and Storage</b>	85°F (29.4°C) maximum

#### Elevation

<b>Operating and Storage</b>	-1000 to 10,000 feet (-304.8 to 3048 meters)
<b>Shipping</b>	-1000 to 40,000 feet (-304.8 to 12,192 meters)

**Note:** Guidelines for storage below 1°C are given in IBM Technical Report TR 07.2112.

#### 7.1.1 Temperature Measurement Points

The following is a list of measurement points and their temperatures (maximum and reliability). Maximum temperatures must not be exceeded at the worst case drive and system operating conditions with the drive randomly seeking, reading and writing. Reliability temperatures must not be exceeded at the nominal drive and system operating conditions with the drive randomly seeking, reading, and writing.

There must be significant air flow through the drive so that the casting and module temperature limits define in Table 15 are not exceeded. Figure 22 on page 78 defines where measurements should be made to determine the top casting temperature during drive operation. Figure 23 on page 79 identify the module locations on the bottom side of the card and the measurement location on the bottom of the casting.

Table 15. Maximum and Reliability Operating Temperature Limits		
	Maximum	Reliability
Disk Enclosure Top	158° F (70° C)	131° F (55° C)
Disk Enclosure Bottom	158° F (70° C)	131° F (55° C)
PRDF Prime Module	203° F (95° C)	176° F (80° C)
WD 61C40 Module	185° F (85° C)	167° F (75° c)
SIC Module	203° F (95° C)	176° F (80° C)
Microprocessor Module	194° F (90° C)	167° F (75° C)
VCM FET	194° F (90° C)	167° F (75° C)
DC/DC Converter (CxB only)	185° F (85° C)	167° F (75° C)
SMP FET	194° F (90° C)	167° F (75° C)

**Note 1:** Module temperature measurements should be taken from the top surface of the module.

**Note 2:** If copper tape is used to attach temperature sensors, it should be no larger than 6 square millimeters.

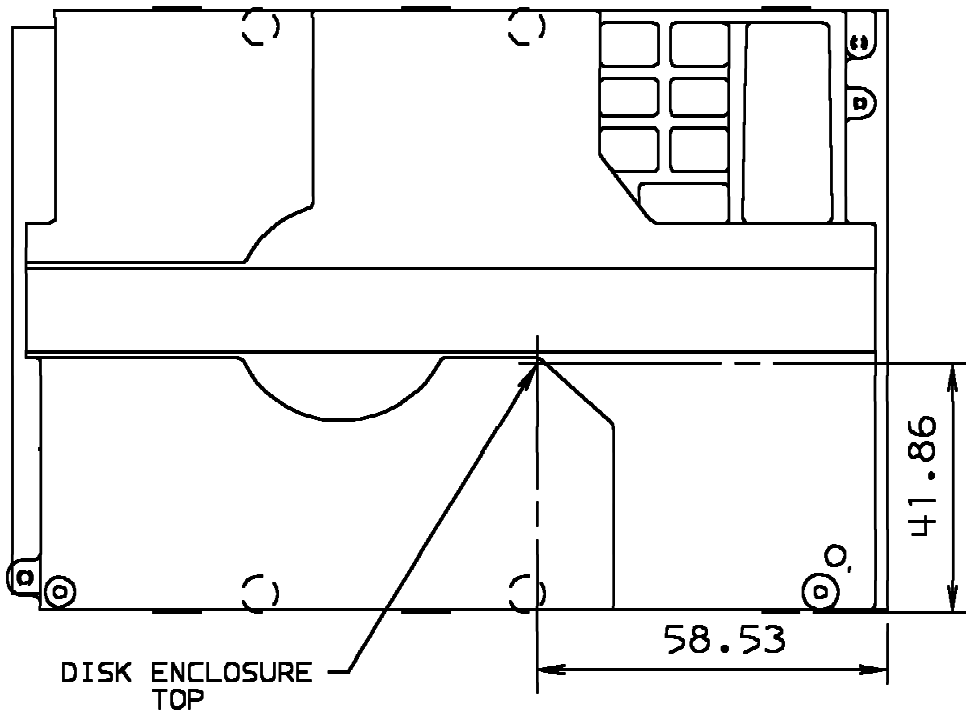

**notes:** 1) dimensions are in millimeters.

Figure 22. Temperature Measurement Points for All Models (top view of DE)

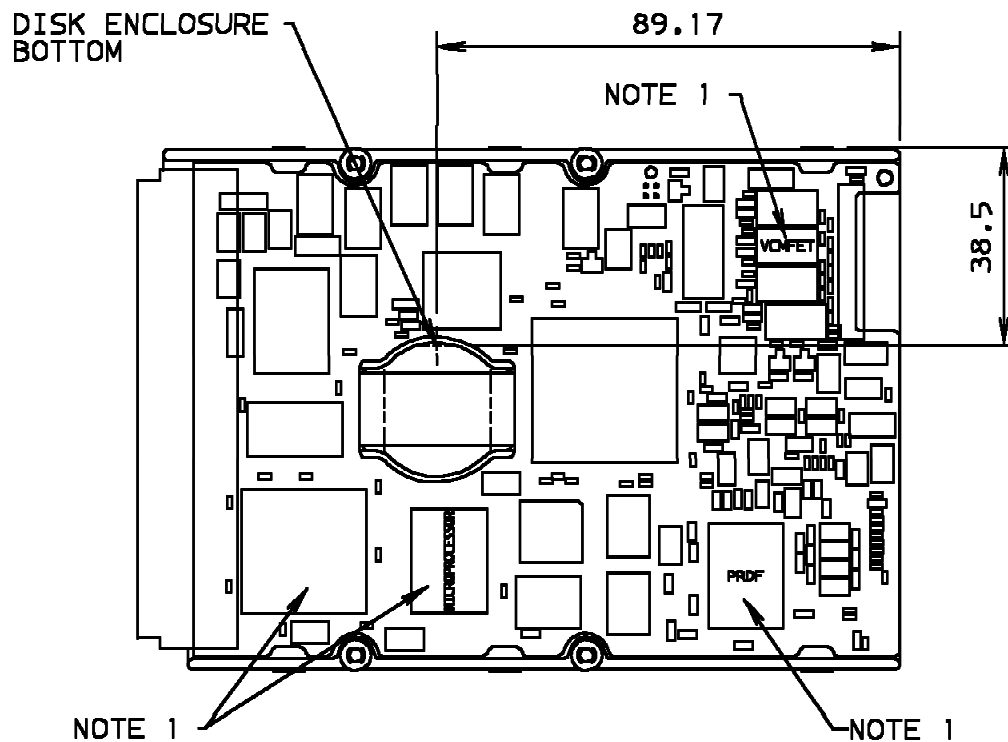

- Notes:**
- 1) Center thermocouple on the top surface of the module.
  - 2) If copper tape is used to attach temperature sensors, it should be no larger than 6 mm square.
  - 3) Dimensions are in millimeters.
  - 4) The connector (on the left edge) does not represent SSA connector.

Figure 23. Temperature Measurement Points for all Models (bottom view)

## 7.2 Vibration and Shock

The operating vibration and shock limits in this specification are verified in two mount configurations for CxC models:

1. By mounting with the 6-32 bottom holes with the drive on 2 mm clearance as required by 4.1.2, "Clearances" on page 51
2. By mounting on any two opposing pairs of the 6-32 side mount holes.

CxB models are mounted rigidly to the test fixture using the carrier guides, connector, and latch mechanism. The test fixture is then mounted to the vibration table (the test fixture must not have any resonance within the frequencies tested).

Other mount configurations may result in different operating vibration and shock performance.

## 7.2.1 Drive Mounting Guidelines

The following guidelines may be helpful as drive mounting systems are being designed.

1. Mount the drive to its carrier/rack using the four extreme side holes to ensure that the drive's center of gravity is as close as possible to the center of stiffness of the mounting.
2. Do not permit any metal-to-metal impacts or chattering between the carrier/rack and the drive or between the carrier/rack and anything else. Metal-to-metal impacts create complex shock waveforms with short periods; such waveforms can excite high frequency modes of the components inside the drive.
3. The carrier/rack should not allow the drive to rotate in the plane of the disk and the carrier/rack itself should be mounted so that it does not rotate in the plane of the disk when the drive is running. Even though the drive uses a balanced rotatory actuator, its position can still be influenced by rotational acceleration.
4. Keep the rigid body resonances of the drive away from harmonics of the spindle speed. Consider not only the drive as mounted on its carrier but also when the drive is mounted to a carrier and then the carrier is mounted in a rack, the resonances of the drive in the entire system must be considered.

7200 RPM Harmonics: 120 hz, 240 hz, 360 hz, 480 hz, .....

5. When the entire system/rack is vibration tested, the vibration amplitude of the drive as measured in all axis should decrease significantly for frequencies above 300 hz.
6. Consider the use of plastics or rubber in the rack/carrier design. Unlike metal, these materials can dampen vibration energy from other drives or fans located elsewhere in the rack.
7. Rather than creating a weak carrier/rack that flexes to fit the drive/carrier, hold the mounting gap to tighter tolerances. A flexible carrier/rack may contain resonances that cause operational vibration and/or shock problems.

## 7.2.2 Output Vibration Limits

spindle imbalance	1.0 gram-millimeters maximum for C1x, C2x models
	1.5 gram-millimeters maximum for C4x model

## 7.2.3 Operating Vibration

The vibration is applied in each of the three mutually perpendicular axis, one axis at a time. Referring to Figure 24 on page 81, the x-axis is defined as a line normal to the front/rear faces, the y-axis is defined as a line normal to the left side/right side faces, and the z-axis is normal to the x-y plane.

**WARNING:** The Ultrastar XP SSA drives are sensitive to rotary vibration. Mounting within using systems should minimize the rotational input to the drive mounting points due to external vibration. IBM will provide technical support to assist users to overcome problems due to vibration.

### Random Vibration

For excitation in the x-direction and the y-direction, the drive meets the required throughput specifications when subjected to vibration levels not exceeding the V4 vibration level defined below.

For excitation in the z-direction, the drive meets the required throughput specifications when subjected to vibration levels not exceeding the V4S vibration level defined below.

**Note:** The RMS value in the table below is obtained by taking the square root of the area defined by the  $g^2/hz$  spectrum from 5 to 500 hz.



Table 16. Random Vibration Levels										
Class	5 hz	17 hz	45 hz	48 hz	62 hz	65 hz	150 hz	200 hz	500 hz	RMS
V4	2.0E-5	1.1E-3	1.1E-3	8.0E-3	8.0E-3	1.0E-3	1.0E-3	8.0E-5	8.0E-5	0.56
V4S	2.0E-5	1.1E-3	1.1E-3	8.0E-3	8.0E-3	1.0E-3	1.0E-3	4.0E-5	4.0E-5	0.55
units	$g^2/hz$									g

Swept Sine Vibration

The drive will operate without hard errors when subjected to the swept sine vibration of 1.0 G peak from 5 to 300 hz in the x- and y direction. For input in the z-direction, an input of 1.0 G peak amplitude can be applied from 5 hz to 250 hz, the amplitude at 300 hz is 0.5 G peak. Linear interpolation is used to determine the acceleration levels between 250 hz and 300 hz.

The test will consist of a sweep from 5 to 300 hz and back to 5 hz. The sweep rate will be one hz per second.

**Note:** 1.0 G acceleration at 5 hz requires 0.78 inch double amplitude displacement.

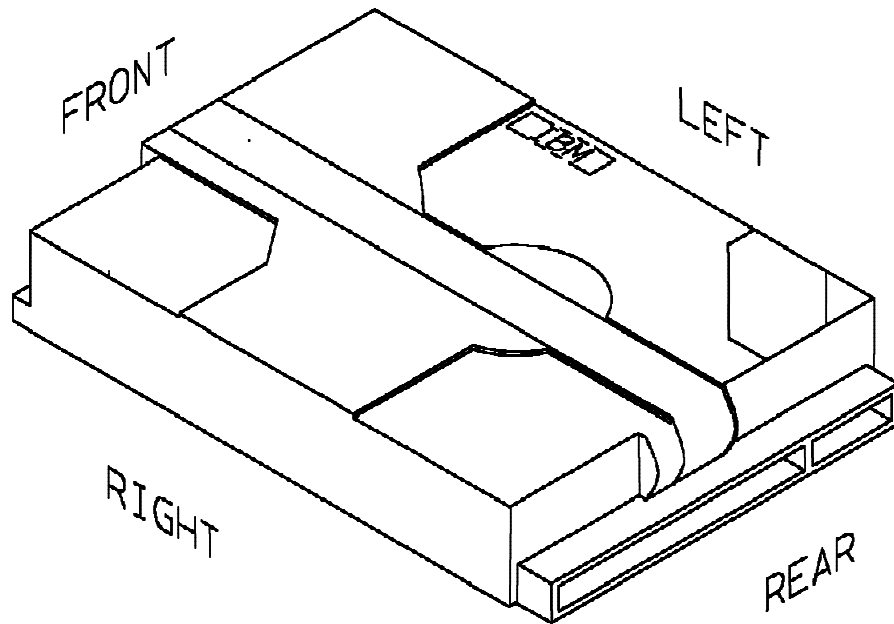

(The connector on the right edge does not represent SSA connector)

Figure 24. Ultrastar XP SSA Drive Small Form Factor Assembly —CxX Models

**7.2.3.1 Nonoperating Vibration**

No damage will occur as long as vibration at the un-packaged drive in all three directions defined above does not exceed the levels defined in the table below. The test will consist of a sweep from 5 hz to 200 hz and back to 5 hz at a sweep rate of eight decades per hour.

Table 17. Non-operating Vibration Levels		
Frequency	5 hz to 7 hz	7 hz to 200 hz
Amplitude	0.8 inch DA	2.0 G peak

## 7.2.4 Operating Shock

No permanent damage will occur to the drive when subjected to a 10 G half sine wave shock pulse of 11 milliseconds duration.

No permanent damage will occur to the drive when subjected to a 10 G half sine wave shock pulse of 2 millisecond duration.

The shock pulses are applied in either direction in each of three mutually perpendicular axis, one axis at a time.

## 7.2.5 Nonoperating Shock

### Translational Shock

No damage will occur if the un-packaged drive is not subjected to a square wave shock greater than a "faired" value of 35 Gs applied to all three axis for a period of 20 milliseconds, one direction at a time.

No damage will occur if the un-packaged drive is not subjected to an 11 millisecond half sine wave shock greater than 70 Gs applied to all three axis, one direction at a time.

No damage will occur if the un-packaged drive is not subjected to a 2 millisecond half sine wave shock greater than 125 Gs applied to all three axis, one direction at a time.

### Rotational Shock

No damage will occur if the un-packaged drive is not subjected to an 11 millisecond half sine wave shock greater than 7,000 radians per second squared applied to all three axis, one direction at a time.

No damage will occur if the un-packaged drive is not subjected to a 2 millisecond half sine wave shock greater than 15,000 radians per second squared applied to all three axis, one direction at a time.

---

## 7.3 Contaminants

The corrosive gas concentration expected to be typically encountered is Subclass G1; the particulate environment is expected to be P1 of C-S 1-9700-000 (1/89).

## 7.4 Acoustic Levels

Upper Limit Sound Power Requirements (Bels) for C1x & C2x Models									
	Octave Band Center Frequency (Hz)							A-weighted (see notes)	
	125	250	500	1K	2K	4K	8K	Maximum	Mean
Idle	4.5	3.5	3.3	3.5	4.5	4.5	4.5	5.00	4.7
Operating	4.5	4.0	3.6	4.1	4.8	4.8	4.5	5.25	5.0

Additionally, the population average of the sound pressure measured one meter above the center of the drive in idle mode will not exceed 36 dB.

Upper Limit Sound Power Requirements (Bels) for C4x Models									
	Octave Band Center Frequency (Hz)							A-weighted (see notes)	
	125	250	500	1K	2K	4K	8K	Maximum	Mean
Idle	4.6	3.5	3.3	3.5	4.5	4.8	4.8	5.0	4.7
Operating	4.6	4.0	3.6	4.1	5.1	4.8	4.8	5.3	5.0

Additionally, the population average of the sound pressure measured one meter above the center of the drive in idle mode will not exceed 41 dBA.

**Notes:**

1. The above octave band and maximum sound power levels are statistical upper limits of the sound power levels. See C-B 1-1710-027 and C-S 1-1710-006 for further explanation.
2. The drive's are tested after a minimum of 20 minutes warm-up in idle mode.
3. The operating mode is simulated by seeking at a rate between 28 and 32 seeks per second.
4. The mean of a sample size of 10 or greater will be less than or equal to the stated mean with 95% confidence.



---

## 8.0 Standards

---

### 8.1 Safety

- UNDERWRITERS LABORATORY (UL) APPROVAL:

The product is approved as a Recognized Component for use in Information Technology Equipment according to UL 1950 (without any Code 3 deviations). The UL Recognized Component marking is located on the product.

- CANADIAN STANDARDS ASSOCIATION (CSA) APPROVAL:

The product is certified to CAN/CSA-C22.2 No. 950-M89 (without any D3 deviations). The CSA certification mark is located on the product.

- INTERNATIONAL ELECTROTECHNICAL COMMISSION (IEC) STANDARDS

The product is certified to comply to EN60950 (IEC 950 with European additions) by TUV Rheinland. The TUV Rheinland Bauart mark is located on the product.

- SAFE HANDLING:

The product is conditioned for safe handling in regards to sharp edges and corners.

- ENVIRONMENT:

IBM will not knowingly or intentionally ship any units which during normal intended use or foreseeable misuse, would expose the user to toxic, carcinogenic, or otherwise hazardous substances at levels above the limitations identified in the current publications of the organizations listed below.

International Agency for Research on Cancer (IARC)

National Toxicology Program (NTP)

Occupational Safety and Health Administration (OSHA)

American Conference of Governmental Industrial Hygienists (ACGIH)

California Governor's List of Chemical Restricted under California Safe Drinking Water and Toxic Enforcement Act 1986 (also known as California Proposition 65)

- SECONDARY CIRCUIT PROTECTION REQUIRED IN USING SYSTEMS

IBM has exercised care not to use any unprotected components or constructions that are particularly likely to cause fire. However, adequate secondary overcurrent protection is the responsibility of the user of the product. Additional protection against the possibility of sustained combustion due to circuit or component failure may need to be implemented by the user with circuitry external to the product. Over-current limit to the drive of 10 Amps or less should provide sufficient protection.

---

### 8.2 Electromagnetic Compatibility (EMC)

- FCC Requirements

Pertaining to the disk drive, IBM will provide technical support to assist users in complying with the **United States Federal Communications Commission (FCC) Rules and Regulations, Part 15, Subpart J Computing Devices "Class A and B Limits"**. Tests for conformance to this requirement are performed with the disk drive mounted in the using system.

- VDE Requirements

Pertaining to the disk drive, IBM will provide technical support to assist users in complying with the requirements of the **German Vereinigung Deutscher Elektriker (VDE) 0871/6.78, both the Individual Operation Permit (IOP) and the General Operation Permit (GOP) Limits.**

- CSPR Requirements

Pertaining to the disk drive, IBM will provide technical support to assist users in complying with the **Comite International Special des Perturbations Radio Electriques (International Special Committee on Radio Interference) CISPR 22 "Class A and B Limits".**

- European Declaration of Conformity

Pertaining to the disk drive, IBM will provide technical support to assist users in complying with the **European Council Directive 89/336/ECC** so the final product can thereby bear the "CE" Mark of Conformity.

## Bibliography

1. *Serial Storage Architecture SSA-PH (Transport Layer)*, X3T10.1/989-D\_rev\_01, January 19th, 1994, Editor: John Scheible.
2. *Serial Storage Architecture SSA-SCSI (SCSI-2 Mapping)*, SSA-UIG/93-036\_rev\_01, January 20th, 1994, Editor: John Scheible.
3. *Serial Storage Architecture SSA-PH (Transport Layer)*, UIG95PH-9509\_Revision\_1, June 19th, 1995, Editor: Adge Hawes.
4. *Serial Storage Architecture SSA-SCSI-2 Protocol*, UIG/95SP-9508\_Revision\_1, May 25th, 1995, Editor: Norman Apperley.
5. *Ultrastar XP (DFHC) SSA Models Interface Specification*, AZ09-0100-04E, February 20th, 1995.
6. *Ultrastar XP (DFHC) SSA Models Product Hardware Specification*, RZ09-0104-04E, Jan 1 st 1994.

DSMBEG323I STARTING PASS 2 OF 2.

DSMAFP709E PAGE SEGMENT CAD3 EXCEEDS RIGHT PAGE BOUNDARY ON PAGE 58.

DSMAFP709E PAGE SEGMENT CAD2 EXCEEDS RIGHT PAGE BOUNDARY ON PAGE 61.



## Free Manuals Download Website

<http://myh66.com>

<http://usermanuals.us>

<http://www.somanuals.com>

<http://www.4manuals.cc>

<http://www.manual-lib.com>

<http://www.404manual.com>

<http://www.luxmanual.com>

<http://aubethermostatmanual.com>

Golf course search by state

<http://golfingnear.com>

Email search by domain

<http://emailbydomain.com>

Auto manuals search

<http://auto.somanuals.com>

TV manuals search

<http://tv.somanuals.com>