

SureMark 4610 Printers



User's Guide for Models TI1, TI2, TI3, TI4, TI8, TI9, TG3, TG4, TG8, TG9, TF6, and TM6

SureMark 4610 Printers



User's Guide for Models TI1, TI2, TI3, TI4, TI8, TI9, TG3, TG4, TG8, TG9, TF6, and TM6

Note

Before using this information and the product it supports, be sure to read Appendix H, "Safety information," on page 197 and the general information under Appendix I, "Notices," on page 203.

April 2009

This edition applies to IBM SureMark Printer Models T11, T12, T13, T14, T18, T19, TG3, TG4, TG8, TG9, TF6 and TM6.

Current versions of Retail Store Solutions documentation are available on the IBM Retail Store Solutions Web site at <http://www.ibm.com/solutions/retail/store/support/>. Click **Publications**.

A form for reader's comments is also provided at the back of this publication. If the form has been removed, address your comments to:

IBM Corporation
Retail Store Solutions Information Development
Department ZBDA
PO Box 12195
Research Triangle Park, North Carolina 27709 USA

When you send information to IBM, you grant IBM a nonexclusive right to use or distribute whatever information you supply in any way it believes appropriate without incurring any obligation to you.

© **Copyright International Business Machines Corporation 1997, 2006.**

US Government Users Restricted Rights – Use, duplication or disclosure restricted by GSA ADP Schedule Contract with IBM Corp.

Contents

Figures	xi
Tables	xiii
Preface	xv
Who should read this manual	xv
How this manual is organized	xv
Related publications and diskettes	xvi
Where to find more information	xvi
Tell us what you think	xvi
Summary of changes	xvii
GA27-4151-07 (April, 2009)	xvii
GA27-4151-07 (February/March, 2007 update)	xvii
GA27-4151-07 (May, 2006)	xvii
Web-only update GA27-4151-06 (December, 2005)	xvii
GA27-4151-06 (August, 2005)	xvii
Web-only update for corrections to GA27-4151-05 (August, 2004)	xvii
Web-only update for corrections to GA27-4151-05 (August, 2003)	xvii
Web-only update for Model T18, GA27-4151-05 (April, 2003)	xviii
Web-only update for GA27-4151-04 (March, 2002)	xviii
Web update for GA27-4151-04 (June, 2001)	xviii
GA27-4151-04	xviii
GA27-4151-03	xix
GA27-4151-02	xx

%

Part 1. General information	1
Chapter 1. Introduction	3
Printer overview	3
Description of models	4
Features used with the SureMark printers	6
Comparison of the SureMark models	7
Planning information	9
Your responsibilities	9
Limitations	9
Communication interfaces	10
Temperature and humidity limits	10
Physical dimensions	10
Power requirements	12
Hardware requirements	13
Software requirements	13
Resident code pages	15
Bar codes	15
Chapter 2. Installation instructions	17
Unpacking the printer	18
Installing a SureMark printer	18
Installing for EIA-232/RS-485 communication	18
Installing SureMark for USB communication	21
Using the wall mounting feature	23
Installing the fillers	24
Installing fillers for EIA-232/RS-485 printers	24

Installing fillers for USB printers 26

EIA-232 communication mode selections (all models except TI8, TI9, TG8, TG9) 28

 Baud rate selection 28

 EIA-232 communications protocol selection 28

EIA-232 communication mode selections (Models TI8, TI9, TG8, TG9) 30

 Baud rate selection 30

 EIA-232 communications protocol selection 30

USB communication mode 31

USB selection 31

Chapter 3. SureMark installation, service, and utility software 33

Software adjustments (Models TI1, TI2, TI3, TI4, TI8, TI9, TG3, TG4, TG8, and TG9). 34

 Offline configurations for Models TI8, TI9, TG8, TG9 34

 Using the IBM Diagnostics for the POS Systems and Peripherals (all models except Models TI1 and TI2) 34

 Using the reference/service diskettes (Models TI1 and TI2) 35

4610 fonts and logos utilities 37

 Utility diskette 37

 IBM Diagnostics for POS Systems and Peripherals package (all models except TI1 and TI2) 37

Proportional font conversion utility 37

Firmware update 37

 Using a firmware update diskette (Models TI1 and TI2 only) 38

 Using POSS for Windows to update SureMark printer firmware (RS-485 and USB only) 39

 Using JavaPOS for Windows to update SureMark printer firmware (EIA-232, RS-485, and USB). 39

 Updating SureMark firmware using temporary EIA-232 attachment 40

 Limitation on updating firmware 41

Emulating the IBM Model 3 or Model 4 printers 41

 Limitations for emulation 41

 Printing saved data 41

Emulating an Epson single-station printer (single-station only) 43

 Enabling Epson emulation 43

 Limitations for Epson emulation 43

MICR data parser sample code (Models TI2, TI4, TI8, TI9, TG4, TG8, and TG9 only) 44

Resources on the Internet 44

Part 2. Models TI1, TI2, TI3, TI4, TI8, TI9, TG3, TG4, TG8, TG9 45

Chapter 4. Operation 47

Operating controls and indicators 47

Ribbon loading 51

Paper loading 53

Clearing jams in the check flipper area 55

MICR reader read head cleaning 56

Thermal print head cleaning 57

Document scanner cleaning (Model TI8, TI9, TG8, TG9) 59

Document scanner calibration (Models TI8, TI9, TG8, TG9) 60

Chapter 5. Testing and problem analysis 61

Testing the printer 61

Offline tests 62

 Customer receipt test 62

%

Document insert test	63
MICR reader and check flipper test (Models TI2, TI4, TI8, TI9, TG4, TG8, and TG9 only)	65
EIA-232 hex dump	66
Resetting the printer - offline	66
Electronic journal dump	66
Problem determination	67

Part 3. Models TF6 and TM6 69

Chapter 6. Operation (Models TF6 and TM6)	71
Operating controls and indicators	71
Paper loading	71
Thermal print head cleaning	73
Chapter 7. Testing and problem analysis (Models TF6 and TM6)	75
Testing the printer	75
Offline test	76
EIA-232 hex dump	77
Resetting the printer - offline	78
Problem determination	78

Part 4. Appendixes. 79

Appendix A. Consumable supplies	81
Paper specifications	81
Thermal paper	81
Document insert forms (Models TI1, TI2, TI3, TI4, TI8, TI9, TG3, TG4, TG8, and TG9 only)	82
Print ribbons (Models TI1, TI2, TI3, TI4, TI8, TI9, TG3, TG4, TG8, and TG9 only)	83
Expendable supplies	83
Appendix B. Printer maintenance procedures	85
Product care procedures	85
Service provider system maintenance procedures	85
Models TI1, TI2, TI3, TI4, TI8, TI9, TG3, TG4, TG8, and TG9	85
Models TF6 and TM6	85
Appendix C. Technical information	87
General description	87
Specifications	87
Memory units	89
Immediate commands	89
Voltage conversion circuitry	89
RS-485 serial I/O parameters	90
Cash drawer connector pin assignments	90
EIA-232 connector pin assignments	91
EIA-232 parameters	91
USB connector pin assignments	92
Code page definitions	92
Generic code page	93
Code page 437	94
Code page 858	95
Code page 860	96

Code page 863	97
Code page 865	98
Character fonts	98
Thermal printing font	98
Impact printing fonts (Models TI1, TI2, TI3, TI4, TI8, TI9, TG3, TG4, TG8, and TG9)	99
Appendix D. EIA-232 programming information	101
EIA-232 commands summary by function	104
Alphabetized EIA-232 commands summary	108
System commands	111
Exercise program	111
Verify previous commands completed	111
Status request	112
Extended address command-request printer ID	112
Preset or Onetime-Set commands	114
All models	114
Models TI8 and TI9 only	114
Download graphics (logo) commands	115
Predefine messages	117
Download user-defined characters	118
Thermal code page	119
Proportional font	120
Impact code page	122
Flash storage write	123
Erase flash EPROM sector	123
Send checksum of flash EPROM sector	124
Microcode tolerance (MCT) information - loading	124
Microcode tolerance (MCT) information - request	125
Setup commands	129
Set print mode	129
Set or cancel double-wide mode	130
Set or cancel double-high mode	131
Set or cancel underline mode	131
Set or cancel overline mode	131
Set or cancel invert mode	131
Set or cancel emphasized printing	132
Select maximum print speed	132
Set or cancel unidirectional printing	133
Request document length for landscape print	133
Set document length for landscape print	133
Set print station	134
Select user-defined or resident character sets	134
Set code page	135
Set intercharacter spacing	135
Set or cancel rotated characters	135
Set print station parameters	136
Select 1/8-inch line spacing	136
Select 1/6-inch line spacing	136
Select color printing	137
Set line spacing using minimum units	137
Set sheet eject length	138
Set horizontal tab positions	138
Set left margin position	138
Set relative position	139
Align positions	139

Set error recovery function	140
Define document wait time	141
Status sent to system	141
Select character for reprinted lines	142
Re-initialize the printer.	142
Enable or disable the feed buttons	143
Enable or disable the beeper (Models TF6 and TM6 only)	143
Enable or disable upside-down printing	144
Select character size for scalable fonts	145
Fix font matrix.	146
Print logo inline	146
Select thermal paper	147
Bar code commands	147
Print bar code	147
Select horizontal size of bar code	152
Select bar code height	152
Select printing position of human readable information (HRI)	152
Select font for HRI	153
Print PDF417 bar code	153
Print PDF417 bar code using binary mode	154
Select PDF417 ECC (error correction codewords) level	154
Select aspect ratio PDF417 bar code	155
Enable PDF417 truncation	155
Print character commands	156
Print and line feed	156
Print and line feed	156
Print, form feed, and cut the paper (FF)	156
Print and feed paper n lines.	156
Print and feed paper using minimum units	156
Print and feed paper in reverse using minimum units	157
Print graphic messages	157
Select and print a graphics (logo) command.	157
Print predefined graphics (logo) command	159
Print predefined messages	159
Miscellaneous commands	160
Tab to next tab stop	160
Return home (select print head location)	160
Paper cut/DI eject	161
Generate drive pulse for cash drawer	161
Retrieve the flash storage	161
Retrieve size of user flash storage	162
Retrieve printer usage statistics	162
Check processing commands (Models TI2, TI4, TI8, TI9, TG4, TG8, and TG9 only)	164
Models TI8 and TI9 MICR read commands	164
MICR read	165
Flip check	166
Document scanner commands.	166
Start scan	166
Print scanned image	168
Store scanned image and/or select partial image for retrieval	169
Retrieve scanned image	172
Scanner calibration	173
Retrieve next image location	174
Retrieve first unread image location.	174
Select compression format and scanned image threshold.	174

Asynchronous (real-time) commands	175
Real-time requests	175
Data buffer management and batch printing	176
Reset line count	176
Disable line count	176
Hold printing until buffer is released	177
Page mode printing commands	177
Select page mode	177
Select standard mode	177
Select printable area	178
Select printing direction/position	178
Set vertical position	178
Set relative vertical position	179
Set left margin position (standard mode), set absolute print position (page mode)	179
Set relative horizontal position	180
Set printing position	180
Print and form feed and cut the paper	181
Print page in page mode	181
Clear print data in page mode	181
Document handling	181
Portrait mode	181
Landscape mode	182
Status summary	184
Message from the printer	184
Status byte 1	184
Status byte 2	185
Status byte 3	185
Status byte 4	185
Status byte 5	186
Status byte 6	186
Status byte 7	186
Status byte 8	186
Appendix E. Uploading electronic journal data	187
Enable the upload of EJ data	187
Disable the upload of EJ data	187
Upload the EJ data	188
Request the size of the EJ space	188
Erase the EJ data in the printer	188
Appendix F. Proportional fonts	189
Preparing the fonts	189
Implementing proportional fonts	189
Layout using align commands	190
Layout using set tab position	191
Appendix G. Emulation support for Epson single-station printer	193
Commands supported in emulation mode	193
Commands with limited support in emulation mode	195
Commands not supported in emulation mode	196
Connectivity differences	196
Functional differences	196
Appendix H. Safety information	197

Appendix I. Notices	203
Electronic emission notices	205
Federal Communications Commission (FCC) statement	205
European Union EMC Directive conformance statement	205
Industry Canada Class A Emission Compliance statement	206
Avis de conformité aux normes d'Industrie Canada	206
Germany	206
Australia and New Zealand	206
Chinese Class A warning statement.	207
Japanese power line harmonics compliance statement.	207
Japanese Voluntary Control Council for Interference (VCCI) statement	207
Korean communications statement	207
Taiwanese Class A warning statement	208
Taiwan contact information	208
Cable ferrite requirement.	208
Electrostatic Discharge (ESD)	208
Product Recycling and disposal	209
Battery return program	210
For Taiwan:	210
For the European Union:	211
For California:	211
Flat panel displays	212
Monitors and workstations	212
Trademarks.	212
Index	213

Figures

1.	IBM SureMark printers	3
2.	SureMark printer dimensions (Models TI1, TI2, TI3, TI4, TG3, and TG4)	11
3.	SureMark printer dimensions (Models TI8, TI9, TG8, TG9)	11
4.	SureMark printer dimensions (Models TF6 and TM6)	12
5.	Cable connectors and EIA-232 settings switch for thermal/impact SureMark printers	18
6.	Cable connectors for single-station SureMark printers	19
7.	EIA-232 mode switches for single-station SureMark printers	19
8.	EIA-232 and RS-485 cable routing for single-station SureMark printers	20
9.	USB Ports for thermal/impact SureMark printers	21
10.	USB ports for single-station SureMark printers	22
11.	USB cable routing for single-station SureMark printers	22
12.	Mounting a single-station SureMark on a wall	24
13.	Installing the fillers for EIA-232/RS-485 systems	25
14.	Installing the fillers for USB systems.	27
15.	SurePOS 500 integration	28
16.	Adjustment and alignment printouts	36
17.	Switch for Epson emulation	43
18.	SureMark printer indicators, controls, and printing stations (Models TI1, TI2, TI3, TI4, TI8, TI9, TG3, TG4, TG8, and TG9)	47
19.	Inserting checks for all models except TF6 and TM6.	48
20.	Inserting checks or documents in a Model TI2, TI4, TI8, TI9, TG4, TG8, or TG9 printer	48
21.	Inserting checks or documents in a Model TI2 or TI4 printer	49
22.	Side insertion of documents in a Model TI8 printer	49
23.	Printable area of an inserted document (portrait)	50
24.	Printable area of an inserted document (landscape)	50
25.	Opening the ribbon cover.	51
26.	Ribbon cartridge loading	51
27.	Ribbon path around the print head	52
28.	Paper cover (Models TI1, TI2, TI3, TI4, TI8, TI9, TG3, TG4, TG8, and TG9)	53
29.	Paper loading path (Models TI1, TI2, TI3, TI4, TI8, TI9, TG3, TG4, TG8, and TG9)	54
30.	Removing the lower document insert cover	55
31.	Removing the check flipper cartridge (except Models TI8, TI9)	56
% 32.	MICR reader read head	57
33.	Print head and print line area (Models TI1, TI2, TI3, TI4, TI8, TI9, TG3, TG4, TG8, and TG9)	58
34.	Scanner and print head location (Model TI8, TI9, TG8, TG9)	59
35.	Printer buttons.	62
36.	Offline printer test pattern from the customer receipt station (Models TI1, TI2, TI3, TI4, TI8, TI9, TG3, TG4, TG8, TG9)	64
37.	MICR reader test results (Models TI2, TI4, and TG4): Good noise level	65
38.	MICR reader test results (Models TI8, TI9, TG8, TG9): Good noise level	65
39.	MICR reader test results: Noise level needs adjusting	66
40.	SureMark printer indicator, control, and printing station (Models TF6 and TM6)	71
41.	Paper loading path (Models TF6 and TM6)	72
42.	Print head and print line area (Models TF6 and TM6)	73
43.	Offline printer test pattern (Models TF6 and TM6)	77
44.	Printer's resident character set - generic code page	93
45.	Code Page 437	94
46.	Code Page 858	95
47.	Code Page 860	96
48.	Code Page 863	97
49.	Code Page 865	98
50.	Proportional font example	122
51.	Scanned image layout	169

52. Scanned image organization 170

Tables

1. Warranty information	5
2. J2 connector pin assignments	12
3. Troubleshooting (Models TI1, TI2, TI3, TI4, TI8, TI9, TG3, TG4, TG8, and TG9).	67
4. Troubleshooting (Models TF6 and TM6)	78
5. Station characteristics	88
6. Sound characteristics	88
7. Cash drawer connector pin assignments	90
8. EIA-232 connector pin functions	91
9. 9-pin to 9-pin EIA-232 connector layout	91
10. 25-pin to 25-pin EIA-232 connector layout	91
11. Standard USB connector pin assignments	92
12. Powered USB connector pin assignments	92
13. Driver documentation by operating system	103
14. EIA-232 commands organized by function	104
15. EIA-232 commands in alphabetical order	108
16. Memory allocation for Models TI8 and TI9 functions	115
17. MCT command definitions	125
18. Fonts for Models TI3, TI4, TG3, TG4, TG8, TG9, TI8, TI9, TF6, and TM6	129
19. Fonts for Models TI1 and TI2	130
20. Width and height for scalable fonts.	145
21. Code 128 character set	149
22. Print bar code examples	152
23. Buffer sizes	158
24. Retrievable usage data	162
25. Data table	172
26. Average size for a personal check with little background data	174
27. Print direction	178
28. Commands supported in Epson emulation mode.	193
29. Commands with limited support in Epson emulation mode	195
30. Commands not supported in Epson emulation mode	196

Preface

This manual assists you with installation, testing, and problem determination of IBM® SureMark™ printers.

Who should read this manual

This manual is intended for use by persons who are installing, testing, or programming an IBM SureMark printer. The manual should also be used for problem determination on the printer.

How this manual is organized

Part 1, “General information,” on page 1 contains information that applies to SureMark printers in general:

- Chapter 1, “Introduction” provides an overview of the features and options of the SureMark printers.
- Chapter 2, “Installation instructions” provides information on installing the SureMark printers.
- Chapter 3, “SureMark installation, service, and utility software” provides information about using SureMark utilities to setup or modify your system configuration.

Part 2, “Models TI1, TI2, TI3, TI4, TI8, TI9, TG3, TG4, TG8, TG9,” on page 45 contains information that is specific to the thermal/impact SureMark printers:

- Chapter 4, “Operation” provides information about the controls and indicators. Ribbon loading and paper loading instructions are also included.
- Chapter 5, “Testing and problem analysis” provides information on testing and on problem determination.

Part 3, “Models TF6 and TM6,” on page 69 contains information that is specific to the single-station SureMark printers:

- Chapter 6, “Operation (Models TF6 and TM6)” provides information on the controls and indicators. Paper loading instructions are also included.
- Chapter 7, “Testing and problem analysis (Models TF6 and TM6)” provides information on testing and on problem determination.

The appendixes contain the following information:

- Appendix A, “Consumable supplies” provides information about consumable supplies.
- Appendix C, “Technical information” provides information about technical specifications.
- Appendix D, “EIA-232 programming information” provides information about EIA-232 programming commands.
- Appendix E, “Uploading electronic journal data” provides information about uploading electronic journal data while the SureMark is in Model 4 emulation mode.
- Appendix F, “Proportional fonts” provides information about creating and using proportional fonts.
- Appendix G, “Emulation support for Epson single-station printer” provides expanded information about Epson emulation mode.

- Appendix H, “Safety information” provides important safety warnings in several languages.
- Appendix I, “Notices” provides information about trademarks and electronic emission notices.
- For California: provides information about perchlorate material.

Related publications and diskettes

- *IBM SureMark Printers: Hardware Service Manual*, GY27-0355
- *IBM SureMark Printers: Fonts and Logos Utility Diskette*
- *IBM SureMark Printers: Firmware Update Diskettes*
- *IBM 4693 Point-of-Sale Terminals Reference Diskette*
- *IBM 4694/4695 Point-of-Sale Terminals Service Diskette*
- *IBM Safety Information—Read This First*, GA27-4004.
- *IBM SurePOS 700 Series: System Reference*, SA27-4220.
- *IBM SurePOS 500 Series: System Reference*, SA27-4255.
- *POSS Programming Reference and User's Guide*, SC30-3560

Diskettes are available by download from the Internet. See “Resources on the Internet” on page 44 for more information.

For information about ordering IBM publications not shipped with the SureMark printers, contact your IBM representative or your place of purchase.

Where to find more information

A CD-ROM is available that contains books that are part of the IBM Retail Store Solutions Library Collection, SK2T-0331.

Current versions of Retail Store Solutions documentation and downloadable diskettes are available on our Web site. See “Resources on the Internet” on page 44 for information about accessing the site.

Tell us what you think

Your feedback is important in helping to provide the most accurate and high-quality information. Please take a few moments to tell us what you think about this book. The only way for us to know if you are satisfied with our books, or how we might improve their quality, is through feedback from customers like you. If you have any comments about this book, there is a comment form at the back of this book. You can also get a copy of the form from the PDF version of the book on the Web.

To access a PDF version of this book, visit the Retail Store Solutions Web site at <http://www.ibm.com/solutions/retail/store/support/>. From there, select **Publications**.

After you have filled out the form, return it by mail, by fax, or by giving it to an IBM representative. If applicable, include a reference to the specific location of the text on which you are commenting. For instance, include the page or table number.

Between major revisions of this manual we may make minor technical updates. The latest softcopy version of this manual is available under Publications on the IBM Retail Store Solutions Web site.

Summary of changes

This section summarizes the changes included in the latest editions of this manual.

% **GA27-4151-07 (April, 2009)**

% This update provides changes to the MICR reader read head cleaning procedures, expandable supplies, and product care procedures.

% Changes or additions to the text are indicated by a change bar (%) to the left of the text.

GA27-4151-07 (February/March, 2007 update)

- Model 3 and Model 4 emulation support notes
 - Various clarifications and corrections
 - Updated notices Appendix I, “Notices,” on page 203
-

GA27-4151-07 (May, 2006)

This update provides new part numbers for existing products that are manufactured using updated methods or materials required in certain jurisdictions, such as the European Union. It also includes other edits based on user feedback.

Web-only update GA27-4151-06 (December, 2005)

This update provides new and updated commands and programming information, and more references to Models T18/TG8 and T19/TG9.

GA27-4151-06 (August, 2005)

This Web-only update adds Model T19 and TG9, as well as references to Model T18.

Web-only update for corrections to GA27-4151-05 (August, 2004)

Corrections and clarifications for:

- “Paper specifications” on page 81
 - “Microcode tolerance (MCT) information - request” on page 125
 - “Re-initialize the printer” on page 142
 - “Start scan” on page 166
 - “Select standard mode” on page 177
 - Minor changes to formatting
-

Web-only update for corrections to GA27-4151-05 (August, 2003)

Corrections and clarifications for:

- “Document scanner calibration (Models T18, T19, TG8, TG9)” on page 60
- Minor changes to formatting

Web-only update for Model T18, GA27-4151-05 (April, 2003)

This update adds the new Model T18 to this *User's Guide*. This model provides document-scanning capability and a powered flipper.

Web-only update for GA27-4151-04 (March, 2002)

This update contains changes to the paper loading procedure for Models TF6 and TM6.

Web update for GA27-4151-04 (June, 2001)

This update contains the following changes and additions:

- The location of the Euro character for code page 858 has been corrected. See "Code page 858" on page 95.
- Information on the new Models TG3 and TG4.
- Command format details about bar codes 128a and 128b.
- Flash memory usage message. See the remarks in Flash storage write on page 123.
- New table for Code 128 character set. See Table 21 on page 149.
- The commands in Appendix D, "EIA-232 programming information," on page 101 are to be used for EIA-232 connections only. Additional information about where to find commands when using RS-485 or USB communications has been added to the beginning of that appendix.

GA27-4151-04

This edition adds information about the new single-station SureMark printers, which are Models TF6 and TM6, and also about updates for Models T13 and T14.

Changes for this edition include:

- Because there are important differences between Models TF6 and TM6, which are single-station SureMark printers, and the thermal/impact SureMark printers, the book has been reorganized into three parts.
 - Part 1 contains information that is similar for all SureMark models. Information about the new single-station printers has been added throughout this part.
 - Part 2 contains information that is specific to the thermal/impact SureMark printer Models T11, T12, T13, T14, TG3, and TG4.
 - Part 3 contains information that is specific to the new single-station SureMark printer Models TF6 and TM6.
- A new thermal font has been added. See "Set print mode" on page 129 and "Thermal printing font" on page 98.
- Support for emulation of an Epson single-station printer has been added. See "Emulating an Epson single-station printer (single-station only)" on page 43 for information about how to enable emulation and an overview of the limitations to using emulation mode. See Appendix G, "Emulation support for Epson single-station printer," on page 193 for detailed information about what Epson commands are supported in emulation mode.
- A font conversion utility has been added as part of the support for proportional fonts. See "Proportional font conversion utility" on page 37.

- Information about uploading electronic journal data while the printer is emulating a Model 4 printer has been added. See Appendix E, “Uploading electronic journal data,” on page 187.
- The following commands have been added:
 - Note:** These commands are not supported for Models TI1 and TI2. Currently installed Model TI3, TG3, TI4, and TG4 printers support these commands after you download the latest firmware.
 - “Proportional font” on page 120
 - “Select color printing” on page 137
 - $n=09$ (Align Column Right) for “Align positions” on page 139
 - “Enable or disable upside-down printing” on page 144
 - “Select character size for scalable fonts” on page 145
 - “Fix font matrix” on page 146
 - “Print logo inline” on page 146
 - “Select thermal paper” on page 147
 - $n=09$ (Code 128A, 128B, and 128C) for “Print bar code” on page 147
- The following command, which is supported only on Models TF6 and TM6, has been added:
 - “Enable or disable the beeper (Models TF6 and TM6 only)” on page 143

GA27-4151-03

This edition includes information for the support of a USB logic card.

Information that was added includes:

- “USB connector pin assignments” on page 92.
- USB information has been added to “Voltage conversion circuitry” on page 89.
- The part number for the available USB cables has been added to “Features used with the SureMark printers” on page 6.
- Information about your responsibilities when using USB communications has been added to “Planning information” on page 9.
- The data rate for USB communications has been added to “Communication interfaces” on page 10.
- USB information has been added to “Hardware requirements” on page 13.
- Information about installing the SureMark printer for use with USB communications has been added to “Installing SureMark for USB communication” on page 21.
- Information about installing fillers for the SureMark printer when the USB feature is used has been added to “Installing fillers for USB printers” on page 26.
- Communication mode information for USB has been added to “USB communication mode” on page 31.
- Relevant information for performing problem determination with USB has been added to Table 3 on page 67.

GA27-4151-02

This edition includes information about two new models of the SureMark printer: Model TI3 and Model TI4. Because Model TI3 is a new version of Model TI1, and Model TI4 is a new version of Model TI2, in some cases only the new model number was added to the existing text.

Information that was added includes:

- “Comparison of the SureMark models” on page 7, which describes the microcode, hardware, and operating system differences.
- “Firmware update” on page 37, which describes the methods that you can use to update the SureMark firmware.
- “Enable or disable the feed buttons” on page 143 and “Select maximum print speed” on page 132, which describe new EIA-232 commands.

Information that was changed includes:

- “Software requirements” on page 13, which includes operating system and driver requirements, and application requirements.
- “Code page definitions” on page 92. Code page 850, which is resident in Model TI1 and TI2, has been replaced in this document by code page 858, which is resident in Models TI3 and TI4. Code page 858 is the same as code page 850 plus the euro character symbol.
- Zero (0) is no longer valid for the EIA-232 command “Microcode tolerance (MCT) information - request” on page 125.
- The Remarks under “Define document wait time” on page 141 have been corrected and expanded.

Because documentation, drivers, and diskettes are now available on the Web, “Resources on the Internet” on page 44 was added to describe how to locate the applicable Web site.

Along with these changes and additions, the manual was also reorganized. The information that was in Appendixes B and E, along with some additional information, is now in Chapter 3, “SureMark installation, service, and utility software,” on page 33.

Part 1. General information

This part contains descriptions of the SureMark printers and information about installing the printers.

Chapter 1. Introduction

Printer overview	3
Description of models	4
Features used with the SureMark printers	6
Comparison of the SureMark models	7
Differences among SureMark models	7
Differences between Models TI3, TI4, TI8, TI9, TG3, TG4, TG8, TG9, and Models TF6, TM6	8
Planning information	9
Your responsibilities	9
Limitations	9
Communication interfaces	10
Temperature and humidity limits	10
Physical dimensions	10
Models TI1, TI2, TI3, TI4, TG3, and TG4	10
Models TI8, TI9, TG8, TG9	11
Models TF6 and TM6	12
Power requirements	12
Hardware requirements	13
Software requirements	13
Operating system requirements	13
Application requirements	14
Resident code pages	15
Bar codes	15

Printer overview

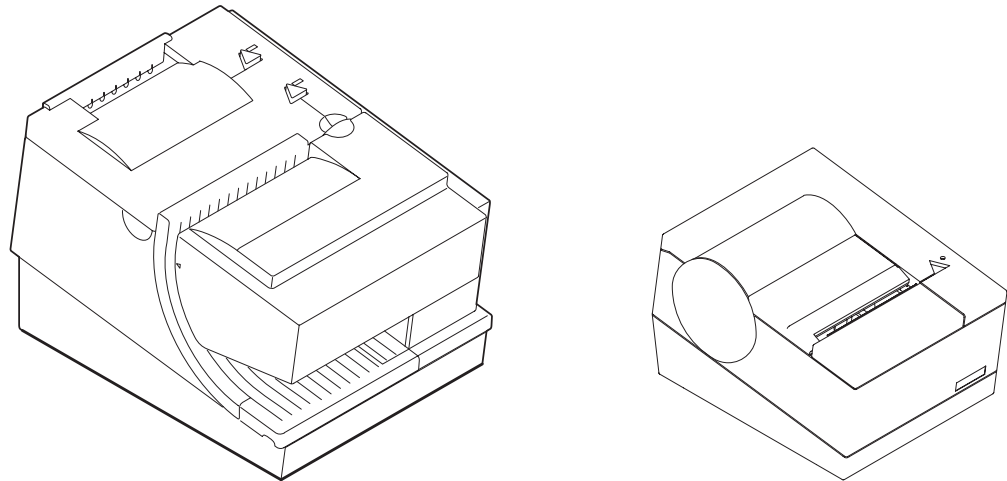

Figure 1. IBM SureMark printers

The IBM SureMark printers are high-performance, high-function printers. The SureMark is available in several models:

- Models TI3, TI4, TG3, and TG4 feature a thermal customer receipt station and an impact document insert station. The dual print heads enable quiet, fast printing at the customer receipt station while providing the capability to print and frank

checks and to print multipart forms through the document insert station. (Models T11 and T12 are older versions of Models T13 and T14, respectively. Production of the older models has ceased.)

- Models T18, T19, TG8, and TG9 provide a document scanner and a powered flipper, in addition to all the features of Model T14.
- Models TF6 and TM6 are single-station thermal printers. They contain no document insert station. These models cost less, weigh less, and have a smaller footprint than the thermal/impact SureMark printers. Models TF6 and TM6 have been designed for wall mounting, if desired by the retailer.

All SureMark printers provide:

- Fast, quiet receipt printing
- Easy paper loading
- 256-KB flash memory for storing messages, logos, code pages, and electronic journal data
- Models T18, T19, TG8 and TG9 have 1 MB of flash memory for scanned image storage
- Bar code generation
- Downloadable fonts and code pages
- Downloadable microcode
- Small footprint
- Support for EIA-232 (RS-232) and RS-485 (EIA-485) interfaces

Note: RS-232 and EIA-232 are synonymous; EIA-232 is used throughout this document. RS-485 and EIA-485 are synonymous; RS-485 is used throughout this document.

- Support for Universal Serial Bus (USB) interface

The single-station SureMark printers, the SureMark Model T18, T19, TG8 and TG9, and SureMark Models T13, T14, TG3, and TG4 that have been updated with the latest firmware, support the following in the thermal station:

- Proportional fonts
- Scalable fonts
- Color printing: black plus one accent on two-color thermal paper (thermal station only)
- Upside-down printing

Additional features of some SureMark models include:

- Single-pass handling of checks (Models T12, T14, T18, T19, TG4, TG8, TG9)
- Easy-to-load ribbon cartridge (Models T11, T12, T13, T14, T18, T19, TG3, TG4, TG8, TG9)
- Epson emulation (Models TF6, TM6)
- Document scanning (Models T18, TG8, T19, TG9)
- Check 21 compliance (Models T19, TG9)

Description of models

Note: All TGx models are functionally equivalent to the corresponding T1x models. TGx models have iron gray covers, while T1x models have pearl white covers.

The SureMark printers are available in the following models:

Models T11 and T13

Standard models that support receipt and document printing. (Model T11 can no longer be ordered.)

Models T12 and T14

High-function models that feature improved check handling. Check handling uses the magnetic character ink recognition (MICR) reader and check flipper that are included in these models. (Model T12 can no longer be ordered.)

With one insertion of a check into a Model T12, T14, T18, or T19 printer, the printer uses its MICR reader to read the magnetic-ink-character line on the check, franks the check, and prints the face of the check. While the printer is processing the check, the operator is free to attend to the customer's needs, which shortens the total transaction time.

Model T18

In addition to the features of the Model T14, these models have a document scanner feature. Scanned documents can be stored and retrieved in TIFF, JPEG, and BMP formats. The Model T18 has increased flipper speed due to a powered flipper. (Model T18 can no longer be ordered.)

Model T19

In addition to the features of the Model T18, the T19 is compliant with Check 21 legislation, which means that it enables single-insertion check handling and scanning of both sides of the full length of the document.

Models TF6 and TM6

Smaller models that contain only a thermal customer receipt station. Because there is no document insert station, these models do not support document printing.

Models TF6 and TM6 have an audible alarm, a spill-resistant design, and an optional wall mount.

For Food Service customers, Model TF6 covers match the IBM SurePOS™ 500 Series systems. For Retail customers, Model TM6 covers match the IBM 4694 systems if the EIA-232/RS-485 interface is ordered, and the covers match the IBM SurePOS 700 Series systems if the USB interface is ordered.

Note: Model TG3 is functionally equivalent to T13, TG4 is functionally equivalent to T14, and so on.

Table 1 shows the warranty information for each printer model.

Table 1. Warranty information

Machine type	Description	Warranty service	Warranty upgrade
4610-T13	EIA-232, RS-485, USB (Pearl white covers)	IOR 24x7	none
4610-T14	EIA-232, RS-485, USB (Pearl white covers)	IOR 24x7	none
4610-T15 (DBCS, AP only)	EIA-232, RS-485, USB (Pearl white covers)	IOR 24x7	none
4610-T18	EIA-232, RS-485, USB (Pearl white covers)	IOR 24x7	none
4610-T19	EIA-232, RS-485, USB (Pearl white covers)	IOR 24x7	none
4610-TM6	EIA-232, RS-485, USB (Pearl white covers)	IOR 24x7	none

Table 1. Warranty information (continued)

Machine type	Description	Warranty service	Warranty upgrade
4610-TM7 (DBCS, AP only)	EIA-232, RS-485, USB (Pearl white covers)	IOR 24x7	none
4610-TF6	TM6 with iron gray covers	Depot repair	IOR 24x7, 9x5
4610-TF7	TM7 with iron gray covers	Depot repair	IOR 24x7, 9x5
4610-IF6	Functionally equivalent to TF6 with iron gray covers but with IOR warranty	IOR 24x7	none
4610-TG3	Functionally equivalent to Model TI3 with iron gray covers	IOR 24x7	none
4610-TG4	Functionally equivalent to Model TI4 with iron gray covers	IOR 24x7	none
4610-TG5 (DBCS, AP only)	Functionally equivalent to Model TI5 with iron gray covers	IOR 24x7	none
4610-TG8	Functionally equivalent to Model TI8 with iron gray covers	IOR 24x7	none
4610-TG9	Functionally equivalent to Model TI9 with iron gray covers	IOR 24x7	none
4610-DG3	Functionally equivalent to Model TG3 but with Depot warranty	Depot repair	IOR 24x7, 9x5
4610-DG4	Functionally equivalent to Model TG4 but with Depot warranty	Depot repair	IOR 24x7, 9x5
4610-DI3	Functionally equivalent to Model TI3 but with Depot warranty	Depot repair	IOR 24x7, 9x5
4610-DI4	Functionally equivalent to Model TI4 but with Depot warranty	Depot repair	IOR 24x7, 9x5
4610-DI8	Functionally equivalent to Model TI8 but with Depot warranty	Depot repair	IOR 24x7, 9x5
4610-DI9	Functionally equivalent to Model TI9 but with Depot warranty	Depot repair	IOR 24x7, 9x5
4610-DM6	Functionally equivalent to Model TM6 but with Depot warranty	Depot repair	IOR 24x7, 9x5
4610-DG8	Functionally equivalent to Model TG8 but with Depot warranty	Depot repair	IOR 24x7, 9x5
4610-DG9	Functionally equivalent to Model TG9 but with Depot warranty	Depot repair	IOR 24x7, 9x5

Note: IOR 24x7 is IBM on-site repair 24 hours times seven days per week. 9x5 is nine hours per day for five days per week.

Features used with the SureMark printers

All models support the following features:

- Integration Panel
- 40-Character VFD or LCD Post Extension
- Distributed Printer Cable (RS-485)
- Integrated Cable (RS-485)

- Short EIA-232 Communications Cable, 2 m (about 6.6 ft), P/N 40N4780
- Long EIA-232 Communications Cable, 4 m (about 13.1 ft), P/N 40N4781
- Power Supply (EIA-232 and USB), P/N 40N5051
- Power Cords (country-specific)
- EIA-232/RS-485 Interface Card

Models TI3, TI4, TI8, TI9, TG3, TG4, TG8, TG9, TM6 and TF6 support the following features:

- USB Cable, Powered, 0.5 m (about 1.6 ft), P/N 40N4715
- USB Cable, Powered, 3.8 m (about 12.5 ft), P/N 40N4716
- USB Cable, Standard, 5.0 m (about 16.4 ft), P/N 40N4767
- USB Interface Card

Because a cash drawer can attach directly to the SureMark, all models also support the following features:

- Compact Cash Drawer, Vertical Till
- Compact Cash Drawer, Horizontal Till
- Full-size Cash Drawer, Adjustable Till
- Full-size Cash Drawer, Fixed Till Insert
- Short Cash Drawer Cable, P/N 40N4778
- Long Cash Drawer Cable, P/N 40N4779

Comparison of the SureMark models

The SureMark models can be divided into three groups:

- Models TI1 and TI2 can no longer be ordered. Because these are not currently being manufactured, they do not support some functions that are on the current models.
- Models TI3, TI4, TI8, TI9, TG3, TG4, TG8, and TG9 have a thermal print station for customer receipts and an impact print station for document processing. These models are currently being manufactured.
 - Models TI8 and TG8 additionally have document scanning.
 - Models TI9 and TG9 additionally have document scanning compliant with Check 21.
- Models TF6 and TM6 have only a thermal print station for customer receipts.

Differences among SureMark models

- Different microcode is required to operate each of the following groups of printers:
 - Models TI1 and TI2
 - Models TI3, TI4, TG3, TG4, TM6, TF6
 - Models TI3, TI4, TG3, TG4, TF6, TM6 with the 2 MB card option
 - Models TI3, TI4, TG3, and TG4 with the 8 MB card option
 - Models TI8, TI9, TG8, and TG9
- Total amount of data space available for the download of graphic messages is 65 376 bytes for Models TI1 and TI2, but only 65 136 bytes for Models TI3, TI4, TG3, and TG4. Models TI8, TI9, TG8, and TG9 have from 0 KB to 1 MB, user allocatable.

- Memory allocated to store incoming commands and data is 16 KB for Models TI3, TI4, TI8, TI9, TG3, TG4, TG8, and TG9, but only 4 KB for Models TI1 and TI2.
- Models TI3, TI4, TI8, TI9, TG3, TG4, TG8, and TG9 operate at higher speeds than Models TI1 and TI2.
- Code page 858, which contains the euro character symbol, is resident in Models TI3, TI4, TI8, TI9, TG3, and TG4. Code page 850, which contains all character symbols from code page 858 excluding the euro character symbol, is resident in Models TI1 and TI2.
- The second byte of the device ID specifies what model of SureMark is being used. The 4690 OS uses the printer model to determine the name of the microcode update file:
 - ADXPJPUF.DAT for Models TI1 and TI2
 - ADXPJPFF.DAT for Models TI3, TI4, TG3, TG4, TM6, TF6
 - ADXPJP2F.DAT for Models TI3, TI4, TG3, and TG4 with the 2 MB card option
 - For microcode update information for Models TI8, TI9, TG8, and TG9, see the IBM Retail Store Solutions Web site at <http://www.ibm.com/solutions/retail/store/support/>.

Differences between Models TI3, TI4, TI8, TI9, TG3, TG4, TG8, TG9, and Models TF6, TM6

Models TF6 and TM6 are single-station thermal printers. These models do not include an impact station. Therefore they can not be used for any of the check handling that thermal/impact SureMark Models TI3, TI4, TI8, TI9, TG3, TG4, TG8, and TG9 support.

The single-station SureMark printers have a lower weight, lower cost, and smaller footprint than the thermal/impact printers. The single-station SureMark printers are designed to provide a cost-effective printer in environments that do not require document printing and check processing.

The single-station SureMark printers are spill-resistant, which makes them a good choice for food service customers. In the single-station printers, the logic card and interface card are mounted vertically, which minimizes the possibility of damage from spills. (In the thermal/impact printers, although the logic card is mounted vertically, the interface card is mounted horizontally.) For particularly hazardous locations, an optional spill cover is available for Models TF6 and TM6.

Models TI3, TI4, TI8, TI9, TG3, TG4, TG8, and TG9 have a trap-door design that allows you to easily change to a new interface, for example when upgrading from EIA-232 to USB. To change the interface on a single-station SureMark, you must remove the bottom cover, then remove both the logic card and the interface card (they are joined by a connector).

The single-station SureMark printers support a 90 mm diameter paper roll, instead of the 80 mm paper roll that is used with the thermal/impact printers. The single-station printers also support an external larger paper roll via RPQ. When the external paper roll is used, the paper feeds into the printer through a slot in the bottom cover of the printer.

A power switch is located inside the top cover of the single-station SureMark printers. Power to the thermal/impact SureMark printers is controlled by the system or by an external power supply.

Because of their smaller size and lighter weight, the single-station SureMark printers are designed for wall mounting. Like the other SureMark printers, they can also be mounted on a system unit or a countertop.

Planning information

This section contains information that helps you plan your environment, supply requirements, and power requirements.

Your responsibilities

You are responsible for replenishing consumable supplies, including roll paper for the thermal (customer receipt station) printer, and, depending on your model, forms, ribbon cartridges for the impact (document insert) station, and MICR read head cleaning cards for the MICR reader. (See Appendix A, “Consumable supplies,” on page 81.)

It is your responsibility to update printer firmware as needed prior to installing printers, and as desired during the printer’s life.

If you plan to use EIA-232 communications, you are responsible for ordering a 24 V dc power supply with a power cord. You are also responsible for ordering the EIA-232 cable.

Note: If a 3-wire EIA-232 cable is to be used, the printer must be set to XON/XOFF mode. (See “EIA-232 communications protocol selection” on page 28.)

If you plan to use RS-485 communications, you are responsible for ordering the RS-485 cable.

If you plan to use USB communications, you are responsible for ordering one of the following:

- A powered USB cable. The 3.8-m USB cable for a distributed configuration is P/N 40N4716 and the 0.5-m USB cable for an integrated configuration is P/N 40N4715.
- A standard USB cable, P/N 40N4767, with a Type B connector for the printer, and a power brick.

With SureMark printer models you can use an electronic journaling application. Electronic journaling eliminates the need to store paper journal tapes and the time-consuming task of searching papers should the need arise.

Limitations

SureMark printers have a safety feature which slows printing if excessive duty cycles are used. This feature protects the printer hardware from potential damage and should not be noticeable during normal operation.

For Model TI2, TI4, TI8, and TI9, sources of electromagnetic noise (for example, displays, security towers, and other sources) can interfere with the MICR read head. The printer is equipped to filter noise from many of these devices. If the MICR reader does not function properly, rearranging the printer relative to the device may improve MICR reading. The noise source should be as far away as possible from the right side of the printer. For additional information on troubleshooting MICR reader problems, see “Offline tests” on page 62.

The single-insert check handling feature of SureMark Models TI2, TI4, TI8, TI9, TG4, TG8, and TG9 is provided as an added convenience when customer service is a priority. Checks in good condition will feed reliably; damaged checks may not.

Communication interfaces

All SureMark printers can support the EIA-232 and RS-485 interfaces. Models TI3, TI4, TI8, TI9, TG3, TG4, TG8, TG9, TM6, and TF6 can also support the USB interface. For SureMark models that can support the USB interface, you can upgrade installed printers from EIA-232/RS-485 to USB by ordering a USB interface card.

EIA-232 supports 9600 and 19 200 bps baud rates and, in the Models TI8, TG8, TI9, and TG9 only, 115 200 bps.

RS-485 operates at a 187.5 Kbps baud rate.

USB supports data rates up to 12 Mbps.

Temperature and humidity limits

Shipping	-40° to 60° C (-40° to 140° F) with 5% to 100% relative humidity including condensation, but excluding rain
Storage	0° to 60° C (32° to 140° F)
Operating	0° to 40° C (32° to 104° F) with 8% to 80% relative humidity

To allow convection cooling, ventilation holes in the covers must not be blocked.

Physical dimensions

Models TI1, TI2, TI3, TI4, TG3, and TG4 all have the same dimensions. Models TI8, TI9, TG8, and TG9 are taller, whereas Models TF6 and TM6 have a smaller footprint.

Models TI1, TI2, TI3, TI4, TG3, and TG4

Width	190.5 mm (7.5 in.)
Depth	255 mm (10 in.)
Height	Front: 140 mm (5.5 in.), Rear: 190 mm (7.5 in.)
Weight	4.4 kg (9.6 lb) without paper

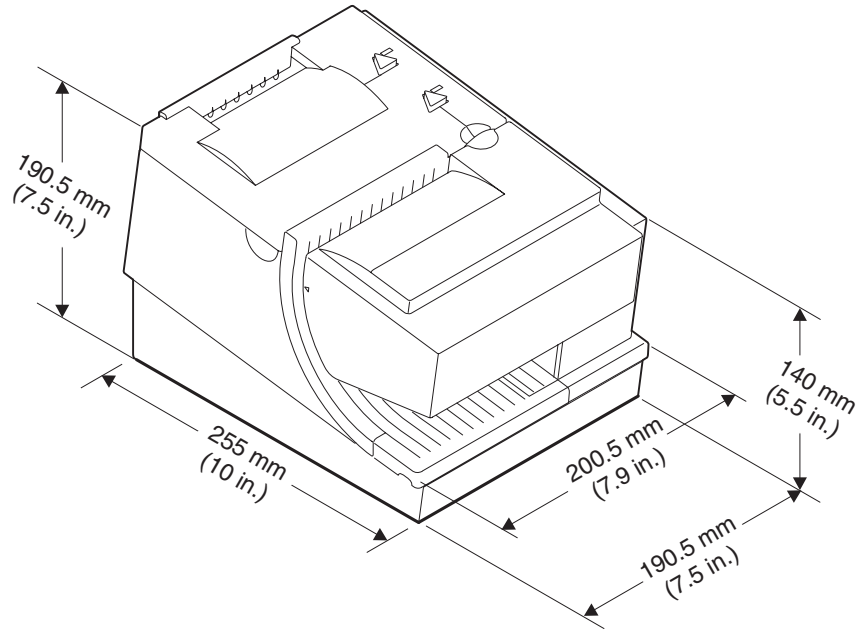

Figure 2. SureMark printer dimensions (Models T11, T12, T13, T14, TG3, and TG4)

Models T18, T19, TG8, TG9

Width	190.5 mm (7.5 in.)
Depth	255 mm (10 in.)
Height	Front: 153.4 mm (6.0 in.), Rear: 199.5 mm (7.9 in.)
Weight	4.9 kg (10.8 lb) without paper

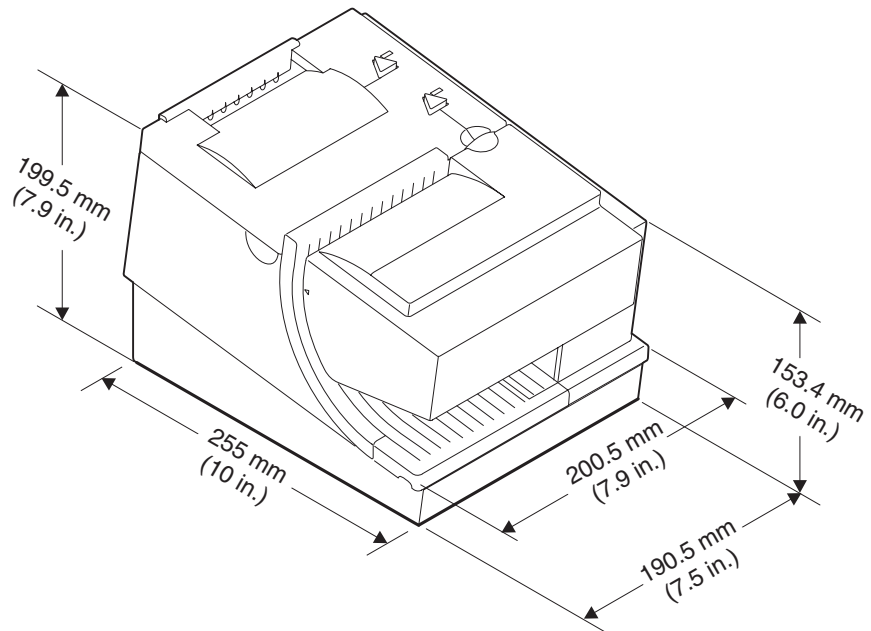

Figure 3. SureMark printer dimensions (Models T18, T19, TG8, TG9)

Models TF6 and TM6

Width	145 mm (5.7 in.)
Depth	177 mm (7.0 in.)
Height	Front: 95 mm (3.7 in.), Rear: 121 mm (4.8 in.)
Weight	1.4 kg (3.0 lb) without paper

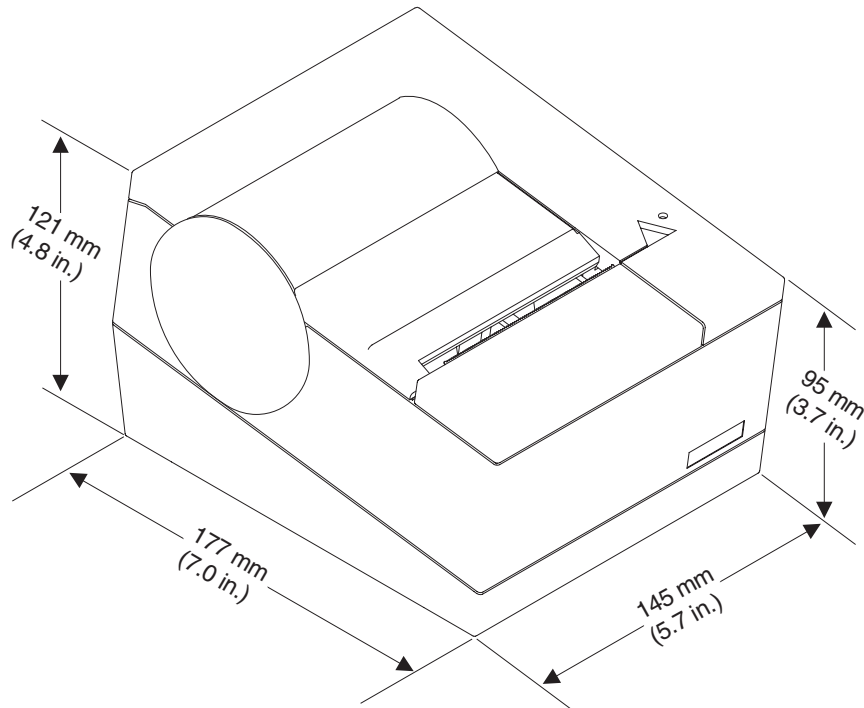

Figure 4. SureMark printer dimensions (Models TF6 and TM6)

Power requirements

SureMark printers do not contain a power supply. When the printer is operating in EIA-232 mode, an external power supply must be attached to connector J2 of the interface card of the printer. This connector is located under the printer and is accessible without removing the printer covers. (See Figure 5 on page 18 for thermal/impact SureMark printers, and Figure 6 on page 19 for single-station SureMark printers.) Connector J2 has the following pin functions:

Table 2. J2 connector pin assignments

Pin	Signal
1	+24 V dc
2	Not Connected
3	Ground

When the SureMark is operating in RS-485 mode, power is supplied to the printer from the IBM POS system. The system supplies 38V dc and 5V dc to the printer.

When the SureMark has the USB feature installed and is using the powered USB cable with a SurePOS 700 Series system, 24 V is supplied from the system unit.

When the SureMark has the USB feature installed and is using a 4-wire cable with a Type B connector, an external power brick (+24 V dc) must be used.

Hardware requirements

SureMark printers work with the following systems:

- IBM 4614 SureOne® POS terminal (EIA-232 connection only)
- IBM 4683 systems (RS-485 connection only)
- IBM 4693 systems
- IBM 4694 systems
- IBM 4695 systems (EIA-232 connection only and with power supply)
- 7497 POS Attachment Adapter (RPQ 8Q1238 in US, RS-485 only)
- PC or other store controller with an EIA-232 or USB port
- SurePOS 700 Series systems
- SurePOS 500 Series systems
- SurePOS 300 Series systems
- IBM Self Checkout solution

Software requirements

Operating system requirements

POSS drivers can be downloaded from the Retail Store Solutions Web site. See “Resources on the Internet” on page 44 for more information.

If you use the RS-485 interface, you must use POSS or 4690 OS drivers. If you use the EIA-232 interface, use the commands described in Appendix D, “EIA-232 programming information,” on page 101.

EIA-232 interface: When using the EIA-232 interface, attach thermal/impact SureMark printers to systems that are running one of these operating systems:

- Windows® XP Professional
- Novell Linux® Point of Service (NLPOS)
- IBM Retail Environment for SUSE Linux
- Windows 2000 Professional with OPOS and JavaPOS support from POS Suite V1.2 or later
- Windows 98 Second Edition or Windows NT® 4.0 with OPOS and JavaPOS support from POS Suite V1.0 or later

When using the EIA-232 interface, attach single-station SureMark printers to systems that are running Windows 2000 Professional, Windows 98 Second Edition, or Windows NT 4.0 with OPOS and JavaPOS support from POS Suite V1.3.1 or later.

RS-485 interface: When using the RS-485 interface, attach thermal/impact SureMark printers to systems that are running one of these operating systems:

- 4690 Operating System Version 1 at maintenance level 9910, 4690 OS V2 or 4690 OS V2R3
- IBM Retail Environment for SUSE Linux
- Novell Linux Point of Service
- IBM PC DOS 2000 or later with POSS for DOS V1.60(b) plus delta package 160(D), or later
- Windows XP Professional
- Windows 2000 Professional with:
 - POSS for Windows from POS Suite V1.1 or later
 - OPOS and JavaPOS support from POS Suite V1.2 or later

- Windows 98 Second Edition or Windows NT 4.0 with POSS for Windows, OPOS and JavaPOS support from POS Suite V1.0 or later

When using the RS-485 interface, attach single-station SureMark printers to systems that are running one of these operating systems:

- IBM PC DOS 2000 with POSS for DOS V2.10 or later (Model TM6 only)
- Windows XP Professional, Windows 2000 Professional, Windows 98 Second Edition, or Windows NT 4.0 with:
 - POSS for Windows from POS Suite V1.3.0 or later
 - IBM Retail Environment for SUSE Linux
 - OPOS and JavaPOS support from POS Suite V1.3.1 or later

USB interface: When using the USB interface, attach thermal/impact SureMark printers to systems that are running one of these operating systems:

- 4690 OS V2R3, which includes JavaPOS 1.4
- Windows XP Professional
- IBM Retail Environment for SUSE Linux
- Novell Linux Point of Service
- Windows 2000 Professional with:
 - POSS for Windows from POS Suite V1.1 or later
 - OPOS and JavaPOS support from POS Suite V1.2 or later
- Windows 98 Second Edition or Windows NT 4.0 with POSS for Windows, OPOS and JavaPOS support from POS Suite V1.0 or later

When using the USB interface, attach single-station SureMark printers to systems that are running one of these operating systems:

- Windows XP Professional, Windows 2000 Professional, Windows 98 Second Edition, or Windows NT 4.0 with:
 - POSS for Windows from POS Suite V1.3.0 or later
 - OPOS and JavaPOS support from POS Suite V1.3.1 or later

Application requirements

Customers must be at these application levels (or higher) when running the 4690 OS:

Application Name	Product Number	Maintenance Level
IBM SUREPOS Application Client/Server Environment for 4690 OS	5745-C44	N/A
IBM Chain Drug Sales Application	5669-212	9701 with PRPQ 5799-QYP
IBM 4680/4690 General Sales Application	5696-546	9701 with APAR IR33229 and PRPQ 5799-QYN
IBM 4680/4690 Supermarket Application	5696-536	9701 with APAR IR33228 plus PRPQ 5799-QYL
StoreFlow™ (see note 1)		Release 1.4
Notes:		
1. Where available, supports Models TI3, TI4, TG3, and TG4 at the point of sale.		
2. 4690 Terminal Services for Windows NT is required when you use Windows NT 4.0 or Windows 2000 as the primary operating system with these 4690 applications.		

Resident code pages

These code pages are resident in the printer:

- Generic
- 437 (US)
- 850 (International) – only Models TI1 and TI2
- 858 (International) – only Models TI3, TI4, TI8, TG3, TG4, TF6 and TM6
- 860 (Portuguese)
- 863 (Canadian French)
- 865 (Norwegian)

Additional code pages (four thermal and two impact) can be downloaded, if desired, using diskettes that are available on the Web. See “Resources on the Internet” on page 44 for more information about downloading diskettes.

Bar codes

SureMark printers can generate these bar codes:

- UPC-A
- UPC-E
- JAN13 (EAN-13)
- JAN8 (EAN-8)
- Code 39
- ITF
- Codabar
- Code 128C
- Codes 128A, 128B, and 128C (only Models TI3, TI4, TI8, TI9, TG3, TG4, TG8, TG9, TF6 and TM6)
- Code 93
- PDF417

Chapter 2. Installation instructions

Unpacking the printer	18
Installing a SureMark printer	18
Installing for EIA-232/RS-485 communication	18
Installing SureMark for USB communication	21
Using the wall mounting feature.	23
Installing the fillers	24
Installing fillers for EIA-232/RS-485 printers	24
Installing fillers for USB printers.	26
EIA-232 communication mode selections (all models except TI8, TI9, TG8, TG9)	28
Baud rate selection	28
EIA-232 communications protocol selection	28
DTR/DSR control	29
XON/XOFF control	29
EIA-232 communication mode selections (Models TI8, TI9, TG8, TG9)	30
Baud rate selection	30
EIA-232 communications protocol selection	30
DTR/DSR control	30
XON/XOFF control	30
USB communication mode	31
USB selection	31

Before installing an IBM SureMark printer, be sure to read “Electronic emission notices” on page 205.



To avoid a shock hazard, do not connect or disconnect any cables or perform installation, maintenance, or reconfiguration of this product during an electrical storm.



To avoid shock hazard:

- The power cord must be connected to a properly wired and earthed receptacle.
- Any equipment to which this product will be attached must also be connected to properly wired receptacles.

Note: For translations of these safety notices, see *IBM Safety Information—Read This First, GA27-4004*.

Unpacking the printer

Note: Save all packing material and shipping containers.

1. Remove the SureMark printer from the shipping container and place it on a flat surface.
2. Open any shipping containers of additional options and accessories to install with the SureMark printer.
3. Carefully remove any remaining packing material and packing tape.

Installing a SureMark printer

This section describes SureMark printer installation.

Installing for EIA-232/RS-485 communication

1. Power the system off and disconnect the EIA-232 power supply.
2. Locate the rear cable connectors.
3. If you are using the EIA-232 communication port:
 - a. For all models except TI8, TG8, TI9, TG9, check the settings on the EIA-232 mode switch, which is near the rear cable connections. See Figure 5 for thermal/impact printers. See Figure 6 on page 19 and Figure 7 on page 19 for single-station printers.

Notes:

- 1) If the EIA-232 communication cable has only 3 wires or if the system output is 3 pins (2 signals and a ground), you must use XON/XOFF mode.
 - 2) Models TI8, TG8, TI9, TG9 do not have a mode switch for EIA-232 settings. See “EIA-232 communication mode selections (Models TI8, TI9, TG8, TG9)” on page 30.
- b. Connect the power supply to the printer.

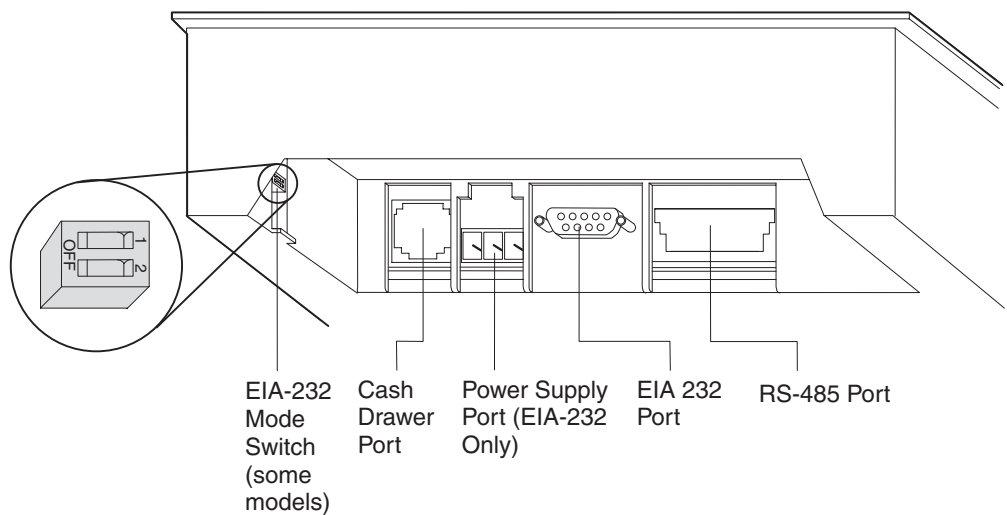

Figure 5. Cable connectors and EIA-232 settings switch for thermal/impact SureMark printers. (View is from the bottom rear of the printer)

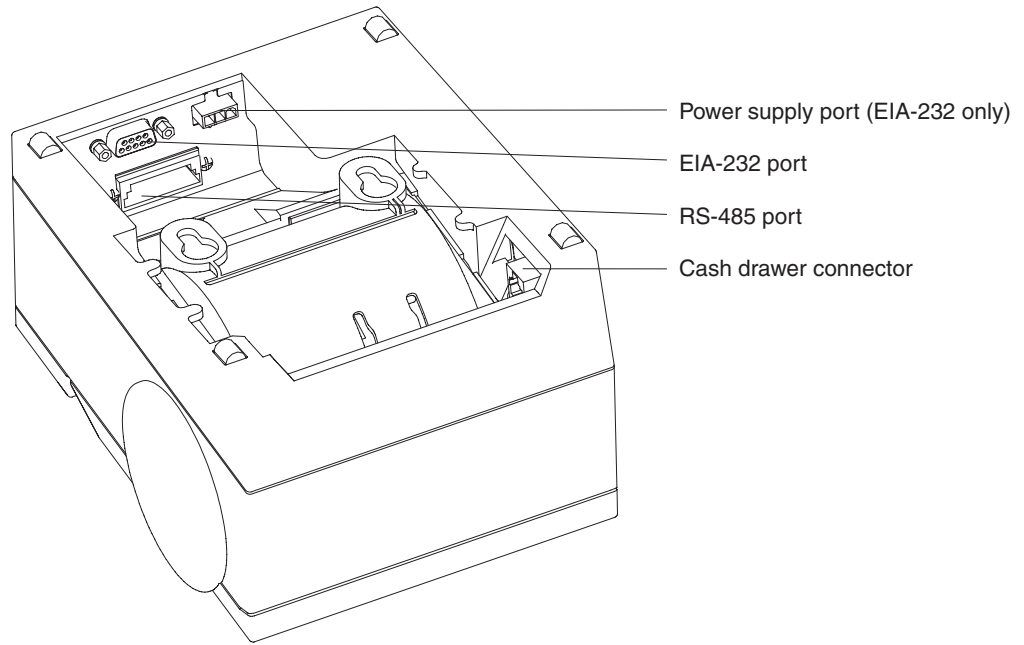

Figure 6. Cable connectors for single-station SureMark printers. (View is from the bottom rear of the printer)

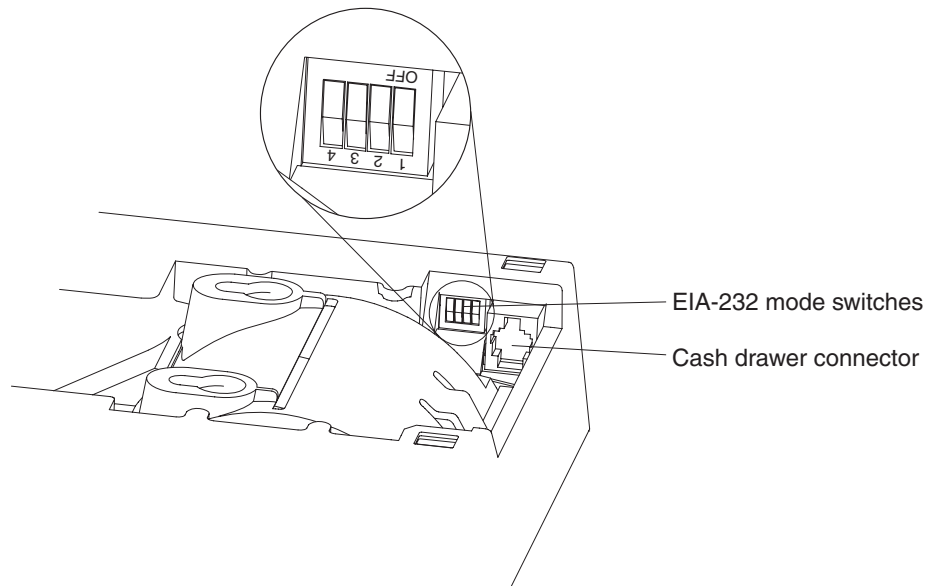

Figure 7. EIA-232 mode switches for single-station SureMark printers. (View is from the bottom rear of the printer)

4. Connect the RS-485 or EIA-232 communication cable to the correct port.
5. For single-station printers, route any power cord and cables as shown in Figure 8 on page 20.

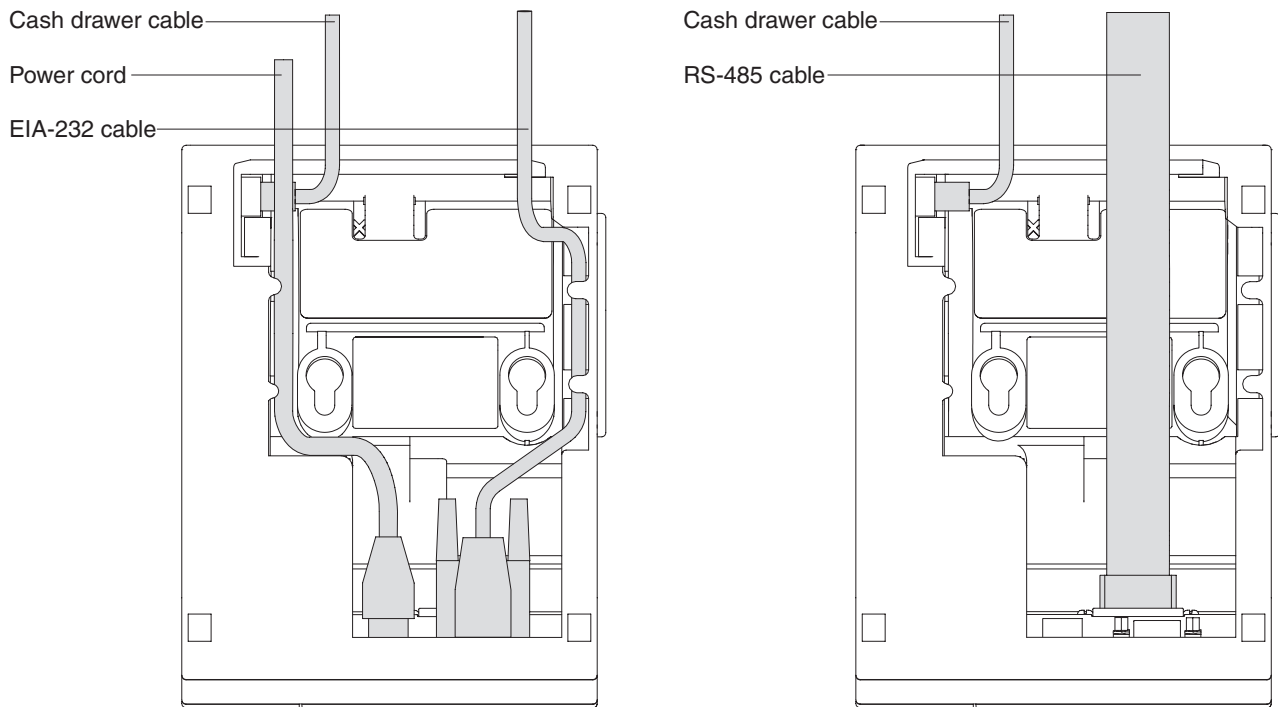

Figure 8. EIA-232 and RS-485 cable routing for single-station SureMark printers

6. Connect any other signal cables for I/O devices to the correct ports.
7. Check that all signal cables are installed and seated in the correct ports.
8. If you are installing the printer on an integrated unit:
 - a. Pull out the locking lever at the left side of the system unit. (wide systems only)
 - b. For single-station printers, place the printer in the square-shaped filler panel.
 - c. Route the keyboard cable to the side of the tab as shown in Figure 13 on page 25.
 - d. Route all cables attached to the printer through the center opening of the system unit and place the printer (with its filler panel, if it is a single-station printer) on the system unit.
 - e. If you have additional fillers to install, go to “Installing the fillers” on page 24.
 - f. Lift the system unit rear cover and attach any cables from the printer to the system unit. (If this is a EIA-232-attached printer, reattach the brick power cord if you had to detach it to route it through the center opening.)
9. Power on the printer by either:
 - Connecting the brick power supply cable to a properly wired and grounded power source and powering it on.
 - Powering on the POS system unit for an RS-485-attached printer.

Attention: Never connect both voltage sources to the printer at the same time, even if one of the sources is powered off. Potential system damage could occur under these conditions.
10. For single-station SureMark printers, turn on the power on/off switch on the printer.

11. For thermal/impact SureMark printers, locate the ribbon cartridge and install it in the printer. (See “Ribbon loading” on page 51.) Be sure that the ribbon is routed through the print head correctly.
12. Load the paper roll into the printer. See “Paper loading” on page 53 for thermal/impact SureMark printers or “Paper loading” on page 71 for single-station SureMark printers.
13. Installation is now complete. Go to Chapter 5, “Testing and problem analysis,” on page 61 for thermal/impact printers or Chapter 7, “Testing and problem analysis (Models TF6 and TM6),” on page 75 for single-station printers and run the offline tests.

Installing SureMark for USB communication

1. Disconnect the power brick from the printer, if one is connected.
2. Locate the rear cable connectors on the printer.

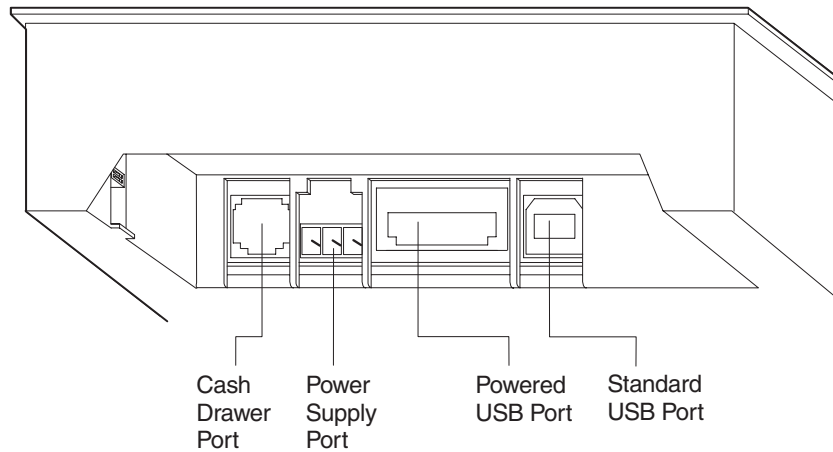

Figure 9. USB Ports for thermal/impact SureMark printers. (View is from the bottom rear of the printer)

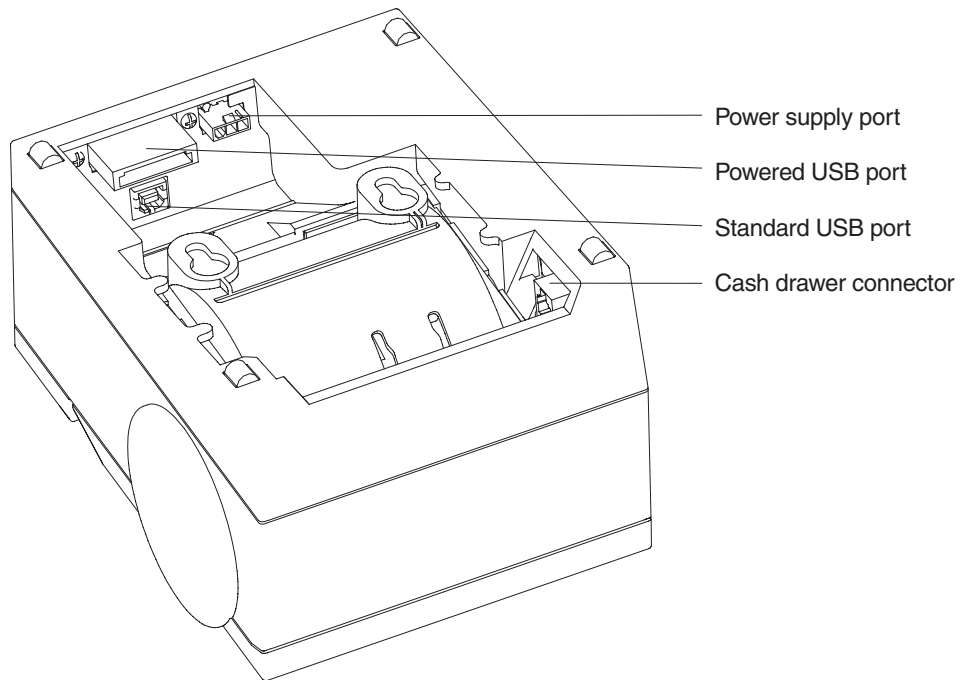

Figure 10. USB ports for single-station SureMark printers. (View is from the bottom rear of the printer)

3. For single-station printers, route any power cord and cables as shown in Figure 11.

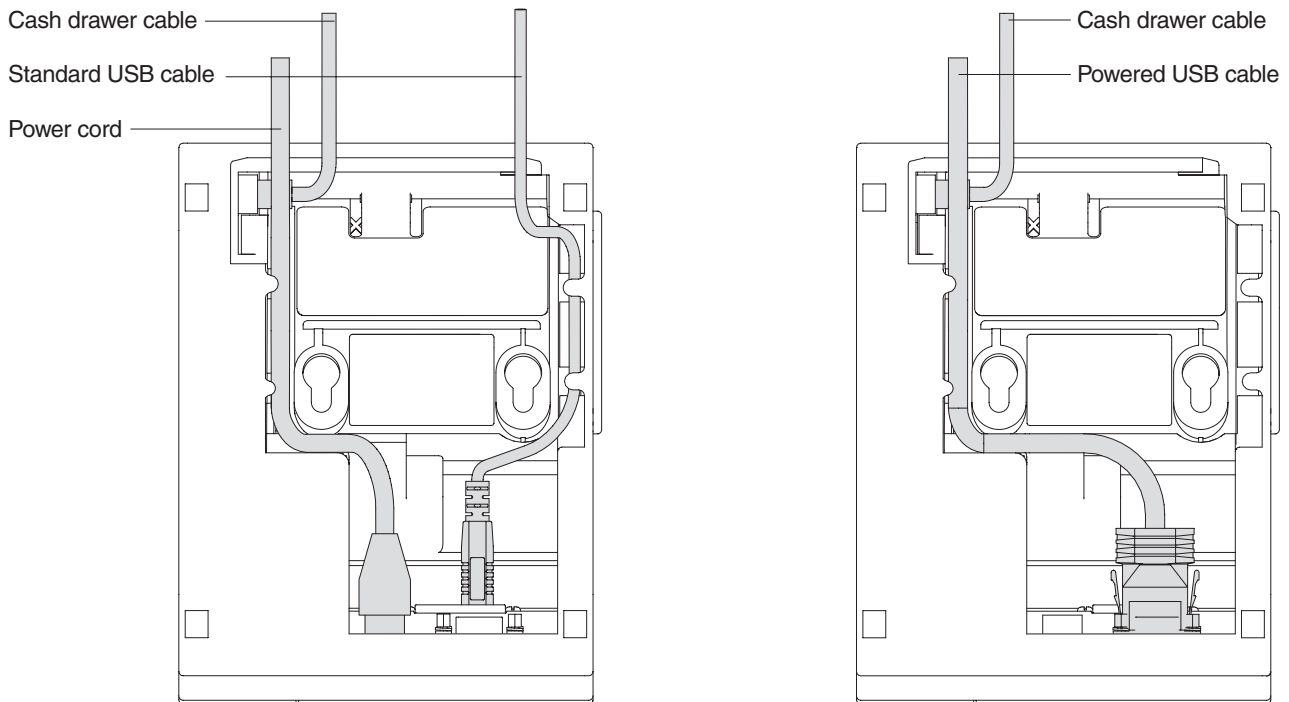

Figure 11. USB cable routing for single-station SureMark printers

4. Connect the USB communication cable to the correct port.
5. Connect any other signal cables for I/O devices to the correct ports.

6. Check that all signal cables are installed and seated in the correct ports.
7. If you are installing the printer on an integrated SurePOS 700 Series system:
 - a. For single-station printers, place the printer in the square-shaped filler panel.
 - b. Route all cables attached to the printer through a rear opening of the system unit and place the printer (with its filler panel, if it is a single-station printer) on the system unit.
 - c. Make the side of the printer overlap the tab on the side of the system unit (wide systems only).
 - d. If you have additional fillers to install, go to “Installing the fillers” on page 24.
 - e. If a fence or I/O tray is installed, lift the system unit rear cover and attach any cables from the printer to the system unit. (If a power brick was disconnected at the beginning of the installation or is needed because a standard USB cable is being used, attach the power brick.)
8. If you are using a power brick, power on the printer by connecting the power brick supply cable to a properly wired and grounded power source and powering it on.
9. For single-station SureMark printers, turn on the power on/off switch on the printer.
10. For thermal/impact printers, locate the ribbon cartridge and install it in the printer. (See “Ribbon loading” on page 51.) Be sure that the ribbon is routed through the print head correctly.
11. Load the paper roll into the printer. See “Paper loading” on page 53 for thermal/impact SureMark printers or “Paper loading” on page 71 for single-station SureMark printers.
12. Installation is now complete. Go to Chapter 5, “Testing and problem analysis,” on page 61 for thermal/impact printers or Chapter 7, “Testing and problem analysis (Models TF6 and TM6),” on page 75 for single-station printers and run the offline tests.

Using the wall mounting feature

Because of their light weight and small footprint, the single-station SureMark printers can be mounted on a wall. This is a useful feature when counter space is limited.

Note: To correctly function in a wall mount, a SureMark printer must have paper roll pivots.

To use the printer with the wall mounting feature:

1. Position the mounting bracket on a wall that has no dangerous objects, such as electrical wires or pipes hidden beneath the wall surface.

Note: Position the bracket so that the installed printer will not extend more than 10 cm (4 in.) into a walk, hall, corridor, passageway or aisle.

2. Attach the bracket securely to the wall with four 6 mm (0.25 in.) screws. The screws are not provided. You should use fasteners that are suitable for the type of wall construction, such that the bracket is securely attached to the wall. For walls that are constructed of gypsum wallboard on wood or metal studs, use four good-quality medium-capacity or high-capacity hollow-wall anchors.
3. Route the communication cable up the wall surface or through the bracket.

4. Connect the cables to the printer.
5. Place the SureMark printer on the two bracket posts. Slide the printer down until a click sounds.

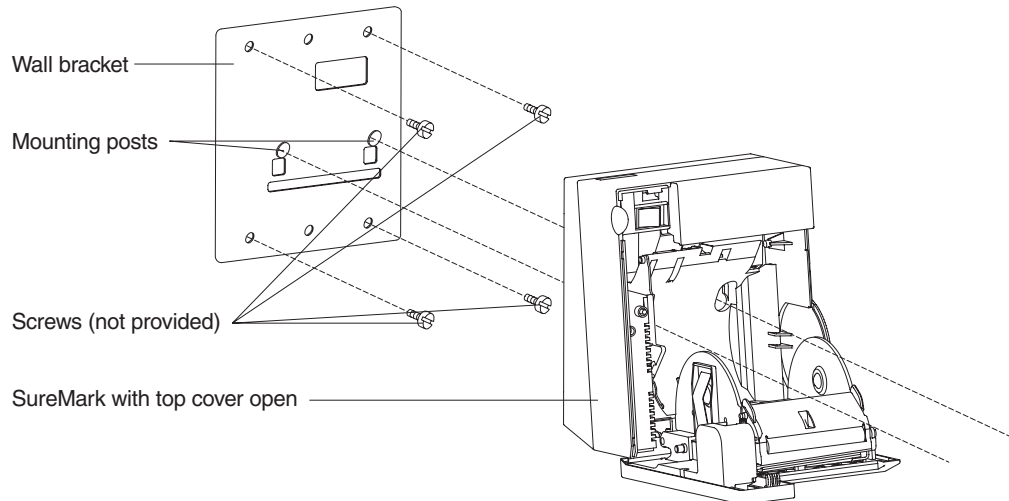

Figure 12. Mounting a single-station SureMark on a wall

Installing the fillers

Installing fillers for EIA-232/RS-485 printers

Notes:

1. On an integrated unit, pull out on the locking lever at the left side of system unit.
2. Ensure that the side of each filler overlaps the tab on the side of the system unit.

To install fillers:

1. Power the system off and disconnect the EIA-232 power supply (if connected). See Figure 5 on page 18.
2. If you have a video display on an integrated system:
 - a. Move the display on its arm to the side and remove any tape holding the alignment ring.
 - b. Remove the knockout section of the display filler.
 - c. Align the display filler with the alignment ring and slide the filler onto the ring. Press the display filler into place. See Figure 13 on page 25.

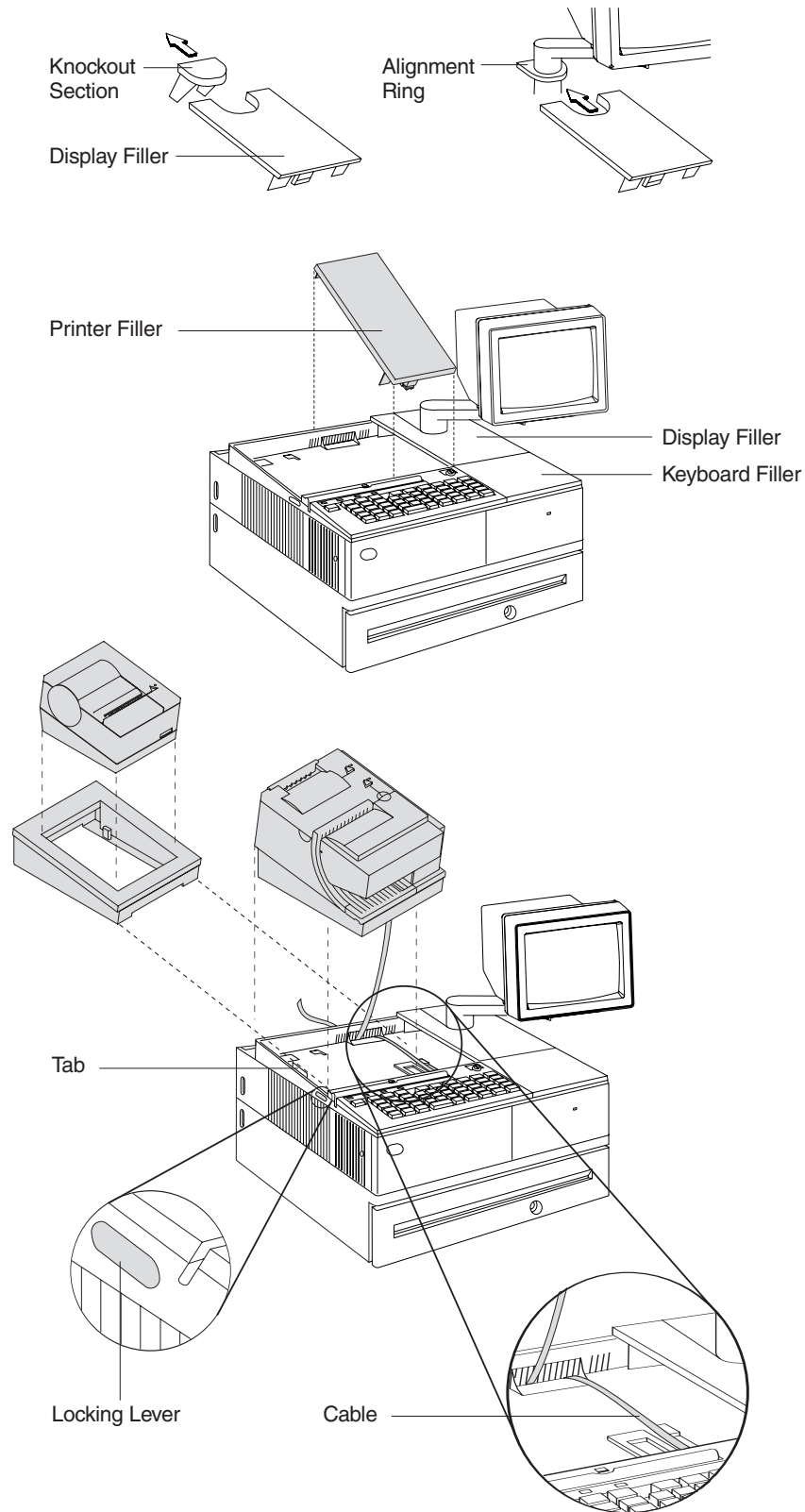

Figure 13. Installing the fillers for EIA-232/RS-485 systems

3. If you do not have a video display, place the display filler on the system unit.

4. If you have a short keyboard, place the keyboard filler beside the keyboard. See Figure 13 on page 25.
5. Place the printer filler beside the display filler. **Make sure you route the printer cable to the side, as shown in Figure 13 on page 25.**

Installing fillers for USB printers

1. Disconnect the power brick from the printer (if connected).
2. Place the display filler appropriate for the video display on the system unit. See Figure 14 on page 27.
3. If you have a short keyboard, place the keyboard filler beside the keyboard. See Figure 14 on page 27.
4. Place the printer filler beside the display filler. **Make sure you route the keyboard cable to the side, as shown in Figure 14 on page 27.**

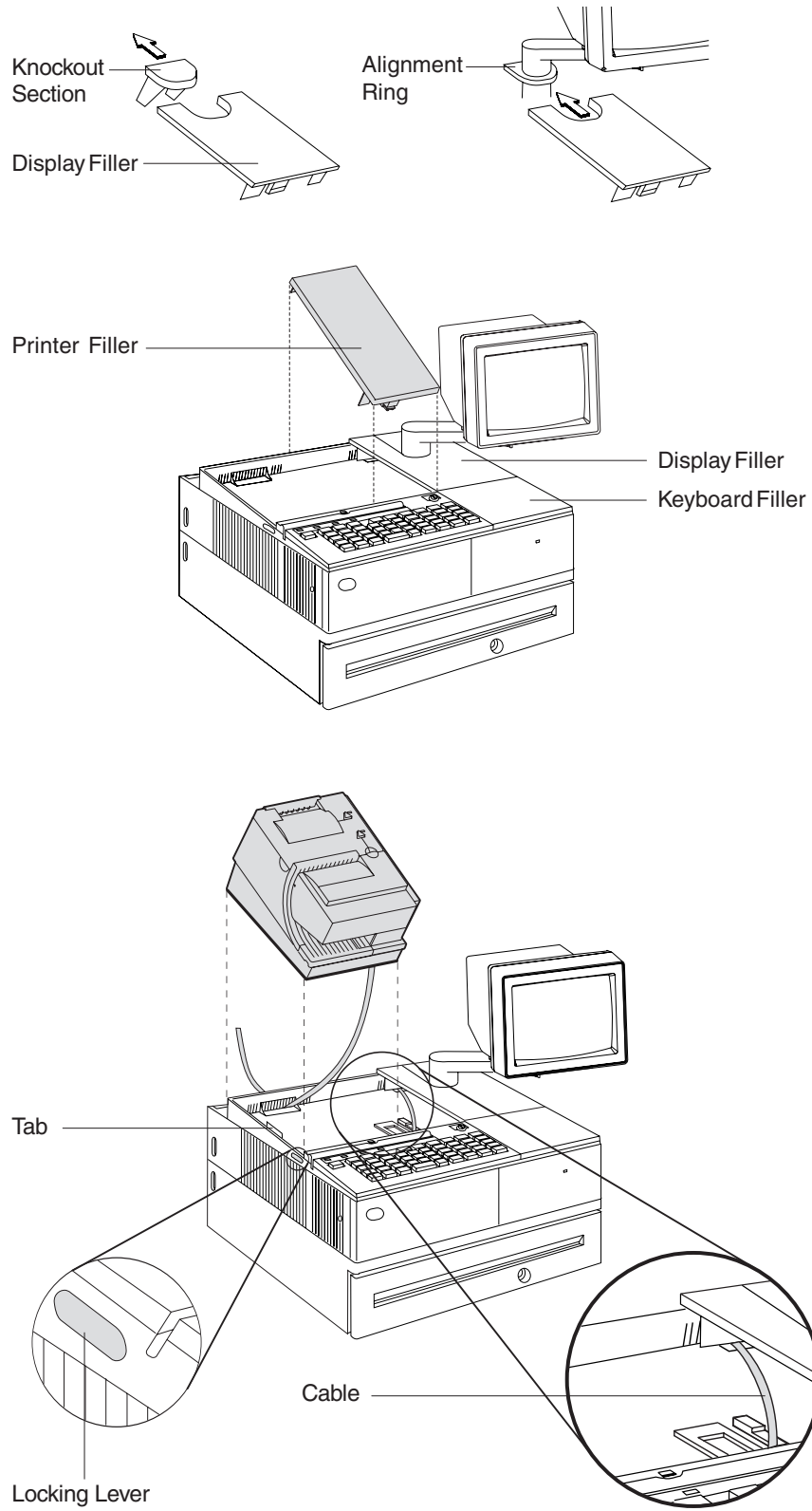

Figure 14. Installing the fillers for USB systems

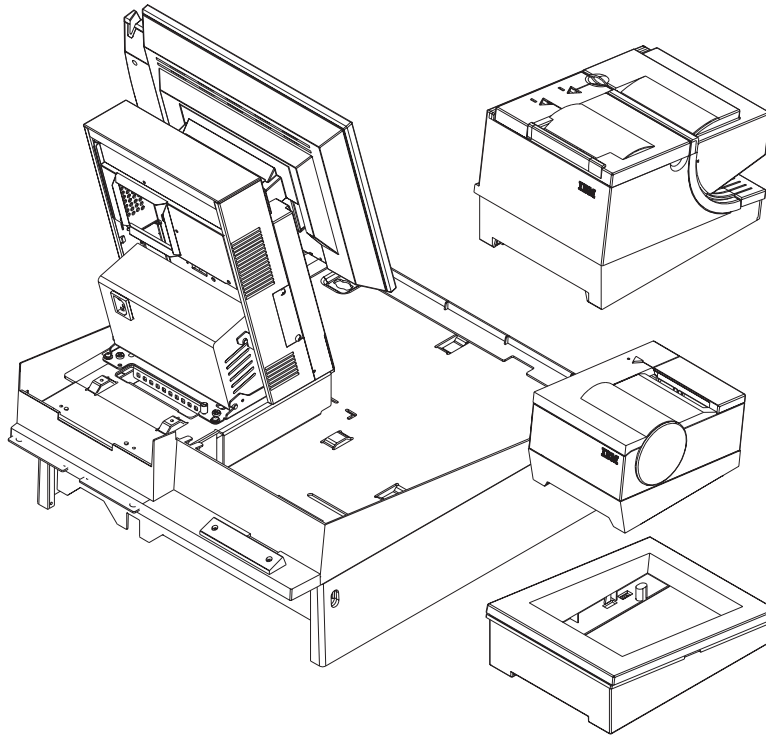

Figure 15. SurePOS 500 integration

EIA-232 communication mode selections (all models except T18, T19, TG8, TG9)

Switch settings described in this section apply only when the printer is connected to the system with the EIA-232 cable. The switch is accessible without removing the printer covers. (See Figure 5 on page 18 to see how to access the switch.)

Baud rate selection

SureMark printers support two EIA-232 baud rates, 9600 and 19 200 bps. The baud rate is selected using switch 1 on the EIA-232 settings switch. Set the switch as follows:

Switch 1 OFF 9600 bps

Switch 1 ON 19 200 bps

The printer normally ships with switch 1 in the OFF position, which selects the 9600 bps baud rate.

EIA-232 communications protocol selection

SureMark printers support EIA-232 protocol using either DTR/DSR or XON/XOFF to control data transmission. XON/XOFF mode uses system and printer software to control the flow of data. This is called *flow control*.

Use switch 2 on the EIA-232 settings switch to select the mode. Switch settings are:

Switch 2 OFF DTR/DSR control

Switch 2 ON XON/XOFF control (required with a 3-wire interface)

The printer normally ships with switch 2 in the OFF position, which selects DTR/DSR control.

DTR/DSR control

DSR DSR is an output from the printer. It indicates when the printer is ready to receive data. A DSR signal becomes inactive when the printer is not ready to receive data (for example, at power-on reset or when its buffer is full).

DTR DTR is an input to the printer. It indicates to the printer that the system is ready to receive data. A DTR signal becomes inactive when the system is not ready to receive data (for example, at power-on reset or when its buffer is full).

XON/XOFF control

XON = DC1 (X'11')

XOFF = DC3 (X'13')

During XON/XOFF control, the printer transmits an XON every 3 seconds after a power-on reset (POR) completes to indicate the printer is ready to receive data. When the first message is received, the printer stops transmitting the XON signal. The printer transmits an XOFF when the EIA-232 input buffer is 80% full, after which it transmits one XON when the buffer is 20% full.

XON/XOFF transparent mode operation: This is the default mode. See “Message from the printer” on page 184 for the format of printer to system messages, which include a byte count, status bytes, and optional extended status bytes or user data.

Transparent mode should always be used when selecting XON/XOFF mode for Models T18 and T19.

XON and XOFF are transmitted independently, and can occur at any point inside or outside of messages transmitted by the printer. When a message includes optional user data, the byte count (bytes 1 and 2) can include X'10', X'11', or X'13'. When X'10', X'11', or X'13' occur in transparent XON/XOFF mode, the byte count is bit-exclusive-ORed with X'21' and is prefixed by the DLE (X'10') character to become:

Value in message	Becomes
X'10'	X'1031'
X'11'	X'1030'
X'13'	X'1032'

User data with X'10', X'11', or X'13' is also treated this way in transparent XON/XOFF mode. The byte count is not incremented for such extra characters.

Determining XON/XOFF control: You can determine whether XON/XOFF control is being used by sending the extended address command and checking the feature byte, bit 3. If this bit is set, the printer is in XON/XOFF mode. (See “Extended address command-request printer ID” on page 112.)

Disabling XON/XOFF transparent mode: You can disable transparent XON/XOFF mode as described in “Real-time requests” on page 175. When

disabled, X'10', X'11', or X'13' can occur within messages. However, because such values are actual count bytes or data bytes and are not XON or XOFF characters (DLE, XON, and XOFF characters do not occur within messages), no transform takes place. The values are not bit-exclusive-ORed with X'21' because no transform occurs for such values within messages as it does during transparent XON/XOFF mode. DLE, XON, or XOFF occur only before or after a message.

EIA-232 communication mode selections (Models TI8, TI9, TG8, TG9)

Settings described in this section apply only when the printer is connected to the system with the EIA-232 cable.

Baud rate selection

You must have power ON and paper installed in the thermal print station.

1. Open both the document cover and the receipt cover.
2. Press and hold both operator buttons until the Customer Receipt (CR) light blinks rapidly.
3. Close the Document Insert (DI) cover. This is the front cover.
4. Close the CR cover. This is the rear cover. A menu is printed on the CR paper.
5. Follow the instructions on the menu to set the baud rate and the communication protocol. The information provided in "EIA-232 communications protocol selection" describes the selections and their purposes.

EIA-232 communications protocol selection

SureMark printers support the EIA-232 protocol using either DTR/DSR or XON/XOFF to control data transmission. XON/XOFF mode uses system and printer software to control the flow of data. This is called *flow control*.

DTR/DSR control

DSR DSR is an output from the printer. It indicates when the printer is ready to receive data. A DSR signal becomes inactive when the printer is not ready to receive data (for example, at power-on reset or when its buffer is full).

DTR DTR is an input to the printer. It indicates to the printer that the system is ready to receive data. A DTR signal becomes inactive when the system is not ready to receive data (for example, at power-on reset or when its buffer is full).

XON/XOFF control

XON = DC1 (X'11')

XOFF = DC3 (X'13')

During XON/XOFF control, the printer transmits an XON every 3 seconds after a POR completes to indicate the printer is ready to receive data. When the first message is received, the printer stops transmitting the XON signal. The printer transmits an XOFF when the EIA-232 input buffer is 80% full, after which it transmits one XON when the buffer is 20% full.

XON/XOFF transparent mode operation: This is the default mode. See "Message from the printer" on page 184 for the format of printer to system messages, which include a byte count, status bytes, and optional extended status bytes or user data.

XON and XOFF signals are always transmitted independently and are not inside any part of the message, including the byte count, status bytes, or user data. When a message includes optional user data, the byte count (bytes 1 and 2) can include X'10', X'11', or X'13'. When X'10', X'11', or X'13' occur in transparent XON/XOFF mode, the byte count is bit-exclusive-ORed with X'21' and is prefixed by the DLE (X'10') character to become:

Value in message	Becomes
X'10'	X'1031'
X'11'	X'1030'
X'13'	X'1032'

User data with X'10', X'11', or X'13' is also treated this way in transparent XON/XOFF mode. The byte count is not incremented for such extra characters.

Determining XON/XOFF control: You can determine whether or not XON/XOFF control is being used by sending the extended address command and checking bit 3 of the feature byte. If this bit is set, the printer is in XON/XOFF mode. (See “Extended address command-request printer ID” on page 112.)

Disabling XON/XOFF transparent mode: You can disable transparent XON/XOFF mode as described in “Real-time requests” on page 175. When disabled, X'10', X'11', or X'13' can occur within messages. The values are not bit-exclusive-ORed with X'21' because no transform occurs for such values within messages as it does during transparent XON/XOFF mode.

Note: Disabling XON/XOFF transparent mode should be done with Model T14 only. It is not recommended with Model T18.

USB communication mode

No switches or special commands are required for USB communication. With the USB interface card and cables in place, the system automatically detects the printer when it is attached and performs any necessary setup. The printer operates at data rates up to 12 Mbps.

USB selection

USB is an industry standard communication interface. It is used to attach devices such as printers, displays, and keyboards to personal computers or to IBM POS systems that have USB ports. The standard USB port (with a power brick) is used to attach the SureMark to personal computers. The powered USB port is used to attach the SureMark to IBM POS systems. See Figure 9 on page 21 for the thermal/impact SureMark printers and Figure 10 on page 22 for the single-station SureMark printers.

Chapter 3. SureMark installation, service, and utility software

Software adjustments (Models TI1, TI2, TI3, TI4, TI8, TI9, TG3, TG4, TG8, and TG9)	34
Offline configurations for Models TI8, TI9, TG8, TG9	34
Using the IBM Diagnostics for the POS Systems and Peripherals (all models except Models TI1 and TI2)	34
Using the reference/service diskettes (Models TI1 and TI2)	35
4610 fonts and logos utilities	37
Utility diskette	37
IBM Diagnostics for POS Systems and Peripherals package (all models except TI1 and TI2)	37
Proportional font conversion utility	37
Firmware update	37
Using a firmware update diskette (Models TI1 and TI2 only)	38
Using POSS for Windows to update SureMark printer firmware (RS-485 and USB only)	39
Using JavaPOS for Windows to update SureMark printer firmware (EIA-232, RS-485, and USB)	39
Automatic update	39
Command line utility (AipFlash46s)	40
Updating SureMark firmware using temporary EIA-232 attachment	40
Limitation on updating firmware	41
Emulating the IBM Model 3 or Model 4 printers	41
Limitations for emulation	41
Printing saved data	41
Printing buffer data on thermal/impact printers	42
Printing buffer data on single-station printers	42
Emulating an Epson single-station printer (single-station only)	43
Enabling Epson emulation	43
Limitations for Epson emulation	43
MICR data parser sample code (Models TI2, TI4, TI8, TI9, TG4, TG8, and TG9 only)	44
Resources on the Internet	44

This chapter describes how to make software adjustments using either the IBM Diagnostics for POS Systems and Peripherals (POSS for Windows, RS-485 and USB only) or diskettes and other resources that are available from the Retail Store Solutions Web site. See “Resources on the Internet” on page 44 for more information.

Software adjustments (Models TI1, TI2, TI3, TI4, TI8, TI9, TG3, TG4, TG8, and TG9)

When a printer main logic card is replaced, the following software adjustments should be run:

- Character alignment procedure (see Figure 16 on page 36)
- Document insert front load print line adjustment (see Figure 16 on page 36)
- Document landscape adjustment (see Figure 16 on page 36)
- Store printer's serial number
- Update the firmware to the latest level
- Reset printer statistics
- Scanner calibration (Models TI8, TI9, TG8, TG9)
- 4610 Model configuration (If the configuration is not set correctly, the printer may act unpredictably.)

Notes:

1. Cards for TI1s and TI2s are set up as TI2s.
2. Cards for Tx3s and Tx4s are set up as Tx4s.
3. Cards for Tx8s and Tx9s are set up as Tx8s.

Depending on your SureMark model, you can use the following to make software adjustments to the printer:

- Offline configuration for Models TI8, TI9, TG8, TG9
- IBM Diagnostics for POS Systems and Peripherals (except Models TI1 and TI2)
- Reference/service diskettes (Models TI1 and TI2 only)

Offline configurations for Models TI8, TI9, TG8, TG9

You must use the calibration procedure to calibrate the scanner.

You must have power ON and paper installed in the thermal print station.

1. Open both the document cover and the receipt cover.
2. Press and hold both operator buttons until the Customer Receipt (CR) light blinks rapidly.
3. Close the Document Insert (DI) cover. This is the front cover.
4. Close the CR cover. This is the rear cover. A menu is printed on the CR paper.
5. Follow the instructions on the menu to:
 - set the EIA-232 parameter
 - set the baud rate
 - set the communication protocol
 - invoke scanner calibration
 - set the 4610 model configuration

The information provided in "EIA-232 communications protocol selection" on page 30 describes the selections and their purposes.

Using the IBM Diagnostics for the POS Systems and Peripherals (all models except Models TI1 and TI2)

The IBM Diagnostics for the POS Systems and Peripherals is a GUI-based diagnostic package on a USB flash drive. It is used to troubleshoot hardware problems, and it includes these 4610 printer utilities:

- Microcode update
- Logo download
- Message download
- Printer Configuration Utility, which includes:
 - Scanner calibration
 - Print current adjustment values (see Figure 16 on page 36)
 - Character alignment procedure (see Figure 16 on page 36)
 - Backlash adjustment (document landscape, see Figure 16 on page 36)
 - DI front load print line adjustment (see Figure 16 on page 36)
 - Set serial number
 - Reset printer statistics
 - Set printer type (4610 model configuration)

Using the reference/service diskettes (Models T11 and T12)

1. Load the reference/service diskette. See the hardware service manual for your system for reference/service diskette procedures.
2. Select **Test Menu**.
3. Select **Run POS Device Tests** for an RS-485 connection. Select **EIA-232 4610 Printer Test** for an EIA-232 connection.
4. If another system is attached, select the system whose printer you want to adjust. This is unnecessary when there is no other system attached.
5. Select **Printer Utilities**.
6. Select the adjustment you want to make from the menu.
 - Print current adjustment values: see Figure 16 on page 36.
 - Character alignment procedure: see Figure 16 on page 36.
 - DI front load print line adjustment: see Figure 16 on page 36.
 - Document landscape adjustment: see Figure 16 on page 36.
 - Engineering use only
 - Change 4610 Model Configuration
 - Reset printer statistics

Note: Because the first four adjustments affect only the document insert station, they are not displayed as selectable options if the printer is a single-station SureMark.

CURRENT ADJUSTMENT VALUES
 H 5 = Character alignment
 TL5 = Top line front insert
 BL3 = Bottom line top insert

TL1 TL2 TL3 TL4 TL5 TL6 TL7 TL8 TL9

Measure from the top edge of this paper to the top of each print line. Press the key (1-9) that corresponds to the print line that is closest to 5MM.

CHARACTER ALIGNMENT PROCEDURE

H	1
H	1
H	2
H	2
H	3
H	3
H	4
H	4
H	5
H	5
H	6
H	6
H	7
H	7
H	8
H	8
H	9
H	9

Press the key (1-9) that corresponds to the pair of H's that appear to be most aligned

5 = selected line

Figure 16. Adjustment and alignment printouts

7. Follow the instructions that are printed on the printer or displayed on the screen.
8. Press S1 (Esc on the Enhanced A/N Keyboard) to return to the previous menu.

4610 fonts and logos utilities

There are utilities available on the Retail Store Solutions Web site. Depending on your model, you may either use the utility diskette or use the IBM Diagnostics for POS Systems and Peripherals package.

The utility program allows you to perform the following functions:

- Update printer firmware
- Configure the printer model
- Create, edit, and download user-defined character fonts, logo images, and messages
- Download proportional fonts (not supported for Models T11 and T12)
- Convert fonts and logo files from impact to thermal

Utility diskette

This utility is for both EIA-232 and RS-485 operation. You can download the utility from the Retail Store Solutions Web site. See “Resources on the Internet” on page 44 for more information.

From the same Web site, you can also download the following sample files for use with the utility program:

- User-defined characters file
- Message file
- Logo file

IBM Diagnostics for POS Systems and Peripherals package (all models except T11 and T12)

This utility is for EIA-232, RS-485, and USB operation. Refer to the README file in this package for details on how to run these utilities.

Proportional font conversion utility

As part of its support for proportional fonts, IBM provides three TrueType fonts and a utility that you can use to convert the fonts to files that the SureMark printer can use.

The application and instructions for downloading the converted fonts are available from the Retail Store Solutions Web site. See “Resources on the Internet” on page 44 for more information.

Note: You might have TrueType fonts other than those supplied by IBM on your system. Before using the conversion utility to convert and download any non-IBM fonts for use by the SureMark printer, you *must* confirm that you have received authorization from the owner of the fonts to convert and download the fonts.

Firmware update

The SureMark printer has the capability to receive SureMark firmware updates from the host system unit to which it is attached for either RS-485-attached, EIA-232-attached, or USB-attached SureMark printers.

The following mediums can be used to update the SureMark firmware:

- Firmware update diskettes

- POSS for Windows 4610 Printer Firmware Update Program
- Alternative 4610 firmware update method via EIA-232 attachment cable

Use the appropriate procedure that follows to update the SureMark firmware, after downloading the latest level software from the Retail Store Solutions Web site (see “Resources on the Internet” on page 44).

Using a firmware update diskette (Models T11 and T12 only)

Use a firmware update diskette to update the firmware in configurations when the SureMark is attached by either an EIA-232 or RS-485 cable and when the system has a floppy diskette drive, a PC keyboard, and display.

1. Download the latest level of firmware update diskette from the Web (see “Resources on the Internet” on page 44). You can select from several update methods, including attended, unattended, and automatic.
2. Insert the firmware update diskette in drive A.
3. Power on the system unit that has the SureMark attached by either an EIA-232 or RS-485 cable.
4. Select RS-485 or EIA-232 connection.
5. Follow the messages displayed to complete the firmware update.
 - a. Press Enter (OK) at the logo screen to proceed.
 - b. Choose connection type (RS-485 or EIA-232). For EIA-232 connections, also make the following selections (refer to the communications mode selections switches, located on the bottom rear of the SureMark printer, to determine the following selections):
 - Communications port (COM1, COM2, COM3, COM4)
 - Baud rate (9600 or 19 200 bps)
 - Control Flow (DTR/DSR or XON/XOFF)
 - c. Press Enter (OK) to proceed.
 - d. Press F10 (Menu).
 - e. Select O (Operations).
 - f. Select A (Advanced Options).
 - g. Select U (Update Firmware).
 - h. Press Enter twice to select the desired firmware image file (usually only the latest firmware image file is available for selection).
 - i. Press Enter (YES) again to commit to firmware update.
 - j. The Information screen will display the update percent completed.

Note: The SureMark flash update will take several minutes. *Do not* power off the host system or the SureMark printer after the update has started.
6. After the firmware update is complete, the SureMark printer will be reset.
 - a. Press Enter (OK) to confirm.
 - b. Press Alt+X (Exit).
 - c. Press Enter to exit.
7. Remove the diskette from drive A.
8. Press Ctrl+Alt+Del to reboot the system.

Using POSS for Windows to update SureMark printer firmware (RS-485 and USB only)

Windows users with SureMark printers can use the POSS for Windows 4610 Printer Firmware Update program (AIPFLD46.EXE) to update SureMark firmware. For additional information, refer to the *POSS Programming Reference and User's Guide*.

Note: POSS Suite V1.0.0 or greater is required to use this utility.

1. Download the latest SureMark firmware update image file from the Web. The file is:
 - AIP46MC.HEX for Models T11 and T12
 - AIP46MCH.HEX for Models T13, T14, TG3, and TG4. This file is also for single-station printers with 512 KB or 8 MB of memory
 - AIP46MCD.HEX for Models T13, T14, TG3, TG4, TF6, and TM6 with the 2 MB memory option.
 - For Model T18, see the IBM Retail Store Solutions Web site at <http://www.ibm.com/solutions/retail/store/support/>.
2. Copy the latest SureMark firmware update image file to the C:\POS\BIN directory. Because the file in the directory is more current than the old file, the firmware will be automatically updated when the system is powered off and back on.
3. To update the firmware manually, enter the **AIPFLD46.EXE -S slot_number -P port_number -F microcode_file [-Q]** command to update the SureMark firmware, where:

slot_number

SureMark slot number, usually = 1. The slot number must be specified with decimal values only; hexadecimal values are not accepted.

port_number

SureMark port number specified with a decimal value, usually = 17

microcode_file

Either C:\POS\BIN\AIP46MC.HEX, C:\POS\BIN\AIP46MCH.HEX, or C:\POS\BIN\AIP46MCD.HEX

-Q (Optional) Quiet mode installation (no progress information)

4. The SureMark flash update will take several minutes.

Using JavaPOS for Windows to update SureMark printer firmware (EIA-232, RS-485, and USB)

The firmware can be updated by automatic update or by the command line utility.

Automatic update

Follow these steps to update the POSPrinter firmware for Linux:

1. Obtain the appropriate flash file from the Web:
 - AIP46MCH.HEX for 4610 Tx3, Tx4 and Tx6
 - AIP46MCD.HEX for 4610 T15 and T17
 - AIP46T18.HEX for T18 and T19

Go to <http://www.ibm.com/solutions/retail/store/support/>. Click the links to JavaPOS POSPrinter support.

2. Create an rs485 directory as follows:

- For Linux, go to the directory `/opt/ibm/javapos/flash` on the target system and create an `rs485` directory. This is done as shown in the following example:

```
% cd /opt/ibm/javapos/flash
% mkdir rs485
```

- For Windows, go to the directory `root install directory\IBMJP05\res\flash` on the target system and create an `rs485` directory. This is shown in the following example, where the root install directory is `C:\POS`.

```
C:\> cd\POS\IBMJP05\res\flash
C:\> mkdir rs485
```

3. Place the correct flash file (ensure it matches the printer type) into the new directory.
4. Make sure the printer is attached and reboot the system. (The flash will take a few minutes to complete during boot-up.)

Command line utility (AipFlash46s)

The IBM 4610 printer firmware can be downloaded using a command utility. The syntax for the utility is `java com.ibm.jpos.util.flash.AipFlash46s [param] [RS-485_flash_filename]`.

Valid values for the variables are:

param -e: flash printer EC level

RS-485_flash_filename

Includes the absolute path name of the flash file (for example:
`/opt/ibm/javapos/flash/aipmch46.hex`)

Updating SureMark firmware using temporary EIA-232 attachment

To use the firmware update diskettes to update SureMark firmware for configurations that *do not* have a floppy diskette drive and PC display and keyboard, you must provide a temporary EIA-232 attachment to a host PC that does have a floppy diskette drive.

Note: A 4610 firmware update diskette at V3.10 or greater is required to use this utility.

Before starting the firmware update, you must obtain the following parts:

- EIA-232 attachment cable, either 2 meters in length (P/N 40N4780) or 4 meters in length (P/N 86H2195).
- SureMark Power Supply for EIA-232 configurations *only* (P/N 40N5051).

If the SureMark is currently attached to a host system unit that does not support a floppy diskette drive, use the following procedure to temporarily connect the printer to a host PC that has a floppy diskette drive, EIA-232 port, PC keyboard and display.

1. Disconnect the SureMark (RS-485 #7) attachment cable and temporarily connect a EIA-232 attachment cable to the SureMark.
2. Connect the SureMark via the EIA-232 port connector to an alternate host PC that has a floppy diskette drive.
3. Follow the procedure in "Using a firmware update diskette (Models T11 and T12 only)" on page 38 to complete the SureMark firmware update.
4. Reconnect the SureMark to the original host system unit using the original attachment cables.

Limitation on updating firmware

The following limitation must be considered when updating firmware on the SureMark printer:

- SureMark firmware update can not be performed if the printer currently has Model 4 emulation enabled. If emulation is enabled, temporarily disable Model 4 emulation, then start the SureMark firmware update. After the firmware update is complete, re-enable Model 4 emulation. See “Emulating the IBM Model 3 or Model 4 printers” for additional information.

Emulating the IBM Model 3 or Model 4 printers

Note: All SureMark firmware levels for Models TI3, TI4, TG3, TG4, TF6 and TM6 support emulation; no other models support this emulation.

It is possible to emulate the IBM Model 3 or Model 4 printer with the SureMark printer. You must change the configuration to enable the SureMark to emulate the Model 3 or Model 4 printers.

To set up the Model 3 or Model 4 emulation, use the IBM Diagnostics for POS Systems and Peripherals package. Refer to the README file in that package for the Change Printer Type utility.

Note: Model 3 and Model 4 emulation is not supported in firmware levels 43 and greater. For the latest level of firmware that includes Model 3 and 4 emulation please use the Model 4 Emulation Support diskette.

Limitations for emulation

The following limitations must be considered when using the SureMark printer to emulate the Model 3 or Model 4 printer.

- Printing the face of checks requires application changes (franking the back of checks should not).
- Printing wide documents may require changes. The document station on the Model 4 printer supports 86 characters, the SureMark supports 47 characters.
- Journal commands can be ignored or stored in the flash memory of the printer. This needs to be decided when the printer is initially configured.
- There is no top document registration (documents must be inserted from the front).
- User-defined special characters are not supported.
- Because SureMark Models TF6 and TM6 do not have a document insert station, they do not emulate document station commands.
- Emulation mode does not support the Model 4A double-byte character set.
- For RS-485, emulation mode is currently only supported on 4690 OS and DOS systems. For USB, emulation mode is currently only supported on 4690 OS. Emulation is not supported for EIA-232.
- On the DI portrait station, 1 inch = 51 motor steps (1 mm = 2 steps). This is different from a Model 3 or 4 printer, where 1 inch = 48 steps.

Printing saved data

When the printer is offline in Model 3 or 4 emulation mode and the option for storing data to the printer is selected, it is possible to fill up the printer flash memory. When the memory is full, a printer error indicates the journal station is out

of paper. You can empty the printer buffer by printing out the data that is stored in the flash memory. The data prints on the customer receipt station. The data in the buffer is erased only after the last line of data is printed.

Note: If the SureMark has the 2 MB option installed, up to three rolls of paper might be needed to print all the electronic journal data.

You can upload an electronic journal while in Model 4 emulation mode. See Appendix E, "Uploading electronic journal data," on page 187 for detailed information.

Printing buffer data on thermal/impact printers

To print the buffer data from the beginning:

1. Press and hold both buttons. When the printer ready indicator begins blinking, release both buttons.
2. Press and release both buttons again.

Notes:

1. If the SureMark printer encounters an error (for example, the paper runs out or the cover is opened) while printing the data, the data remains intact.
2. To stop printing the data, open and close the ribbon cover. When you are ready to print the data, use the procedure above to restart printing from the beginning.
3. To stop printing and restart at the current position, open and close the paper cover. Printing immediately restarts.

Printing buffer data on single-station printers

To print the buffer data from the beginning:

1. Open the top cover. The LED will flash quickly.
2. Press and hold the paper feed button for 5 seconds.

Note: The paper feed button is the small button next to the LED.

3. The LED will show one short blink, accompanied by a beep, followed by a 1 second pause.
4. Press and hold the paper feed button for 5 seconds.
5. The LED will change to a long blink. The beeper will sound continuously.
6. Close the cover to begin printing the electronic journal data.

Notes:

1. If the SureMark printer encounters an error (for example, the paper runs out or the cover is opened) while printing the data, the data remains intact.
2. To stop printing the data, open the top cover, turn the printer power switch OFF, turn the printer power switch back ON, and close the top cover. When you are ready to print the data, use the procedure above to restart printing from the beginning.
3. To stop printing and restart at the current position, open and close the top cover. Printing immediately restarts.
4. To return the printer to normal mode, press and release the paper feed button a third time before closing the top cover.

Emulating an Epson single-station printer (single-station only)

Emulation of an Epson single-station printer is supported on the single-station SureMark printers. See Appendix G, “Emulation support for Epson single-station printer,” on page 193.

Enabling Epson emulation

To enable emulation of an Epson single-station printer on a single-station SureMark printer, you must set switch 3 on the main logic card. See Figure 17 for the location of the switch.

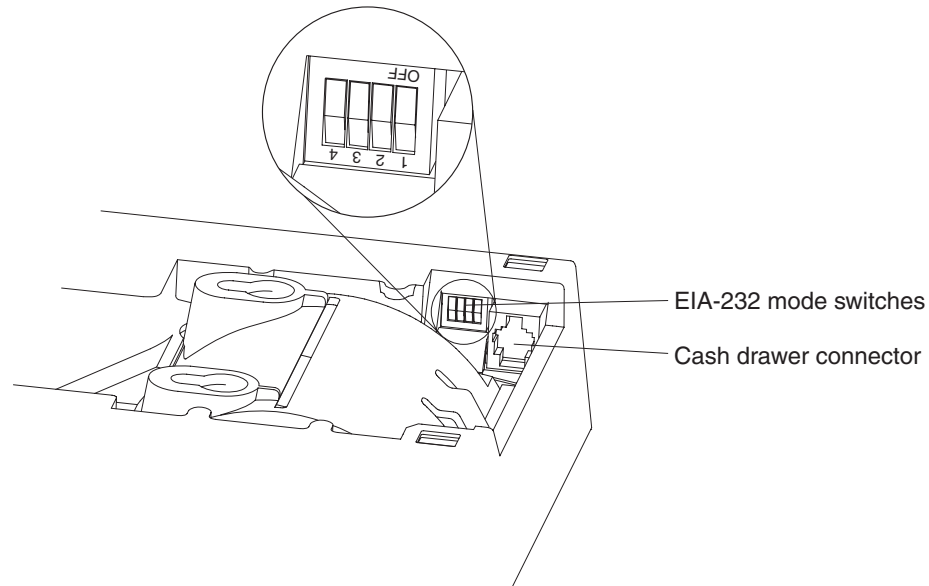

Figure 17. Switch for Epson emulation

Limitations for Epson emulation

The following limitations must be considered when using a single-station SureMark printer to emulate an Epson single-station printer:

- Logos and downloadable characters are supported in emulation mode. However, because the Epson printer prints at 180 dpi and the SureMark prints at 200 dpi, the emulated printout will be smaller.
- Emulation of page mode is not supported on the SureMark.
- Epson supports the *Select paper sensor to stop printing* command. IBM does not support a low paper sensor.
- In order to implement fixes, new functionality, and other improvements, new releases of printer microcode are routinely published. It is advisable that you run the most recent version of firmware on the printer; however, the 4610 firmware can not be updated when running in Epson emulation mode. Therefore, you must first switch the printer to native mode, to upgrade the microcode.

MICR data parser sample code (Models T12, T14, T18, T19, TG4, TG8, and TG9 only)

The MICR data parser download package includes:

- Sample source code (in C) that contains algorithms for parsing MICR data from a check.
- An exception data file that is used with the parsing code. You can edit this file to add new check formats, if necessary.

Refer to the README file in this download package for additional information.

Resources on the Internet

The IBM Retail Store Solutions Web site at <http://www.ibm.com/solutions/retail/store/support/> contains publications for the SureMark printer. The Web site also provides access to diskettes, drivers, and miscellaneous documentation, such as README files and information about OEM papers that have been certified.

Select **IBM SureMark Printer**. The displayed page contains links both to documentation and to diskettes and drivers that you can download for the SureMark printers.

Part 2. Models TI1, TI2, TI3, TI4, TI8, TI9, TG3, TG4, TG8, TG9

This part contains operational, testing, and problem determination information for the thermal/impact SureMark printers Models TI1, TI2, TI3, TI4, TI8, TI9, TG3, TG4, TG8, TG9. All references to Model TI3 pertain to Model TG3, references to TI4 pertain to Model TG4, and so on.

Chapter 4. Operation

Operating controls and indicators	47
Ribbon loading	51
Paper loading	53
Clearing jams in the check flipper area	55
MICR reader read head cleaning	56
Thermal print head cleaning	57
Document scanner cleaning (Model T18, T19, TG8, TG9)	59
Document scanner calibration (Models T18, T19, TG8, TG9)	60

Note: All covers *must* be installed on the SureMark printer during operation.

Operating controls and indicators

There are two triangular-shaped buttons and two LED indicators located on top of the printer. The buttons serve multiple functions.

When the topmost indicator is on continuously, the printer is powered ON and ready for printing. When the indicator blinks, one of the following conditions exists:

- The printer is out of paper.
- The cover is open.
- The printer is offline.
- The printer has a nonrecoverable home error.

The second LED is the Document Present indicator. It lights when a document is inserted far enough into the document insert station to reach the DI sensor. When this LED blinks, the DI station is waiting for you to insert a document.

The topmost button is the customer receipt paper feed button. Press this button to advance the CR paper. The lower button is the document feed button. Press this button to advance the document.

If you press both buttons at the same time and then release them, the document insert throat opens. The throat must be open to insert a document from the side. Press and then release both buttons again to close the throat.

Both buttons are also used to test the printer. See “Offline tests” on page 62 for additional button functions.

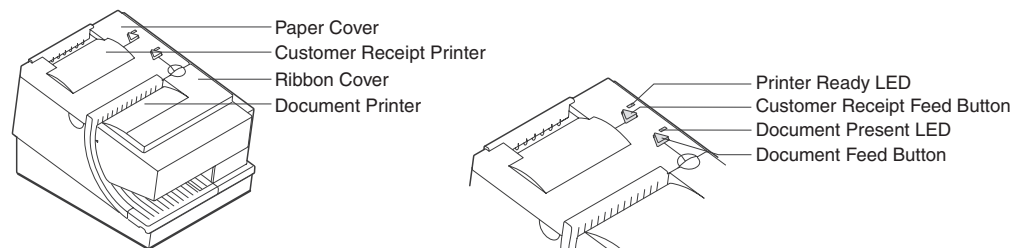

Figure 18. SureMark printer indicators, controls, and printing stations (Models T11, T12, T13, T14, T18, T19, TG3, TG4, TG8, and TG9)

The printer is capable of printing verification information on a check and printing information on an inserted document. Figure 19 on page 48, Figure 20 on page 48, and Figure 21 on page 49 show the correct positioning of checks and documents in

SureMark printers with impact (document insert) stations. Those figures also show how to side load a document to align it exactly where you want it to be printed.

Notes:

1. When side loading a Model T18 or TG8, the document must be placed lower than with the other models.
2. Side loading is not available with Models T19 and TG9.

Insertion of Check for MICR Reading and Franking

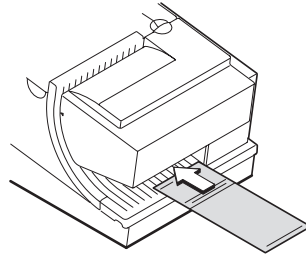

Insertion of Check for Printing the Face

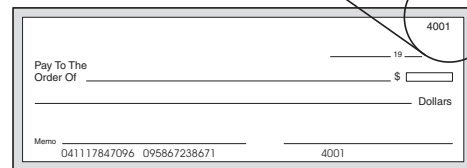
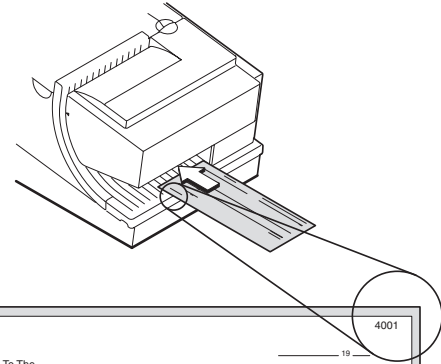

Figure 19. Inserting checks for all models except TF6 and TM6

Insertion of Document (Front Load)

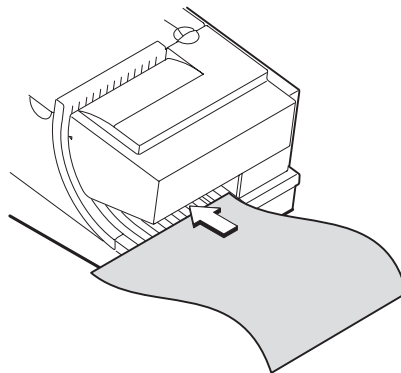

Figure 20. Inserting checks or documents in a Model T12, T14, T18, T19, TG4, TG8, or TG9 printer

Insertion of Document (Side Load)

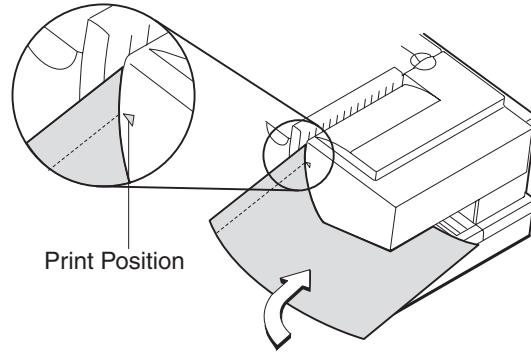

Figure 21. Inserting checks or documents in a Model T12 or T14 printer

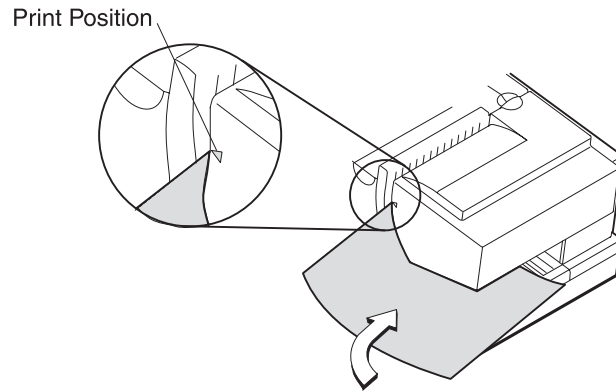

Figure 22. Side insertion of documents in a Model T18 printer

Figure 23 and Figure 24 on page 50 show the printable area on an inserted document for both portrait and landscape.

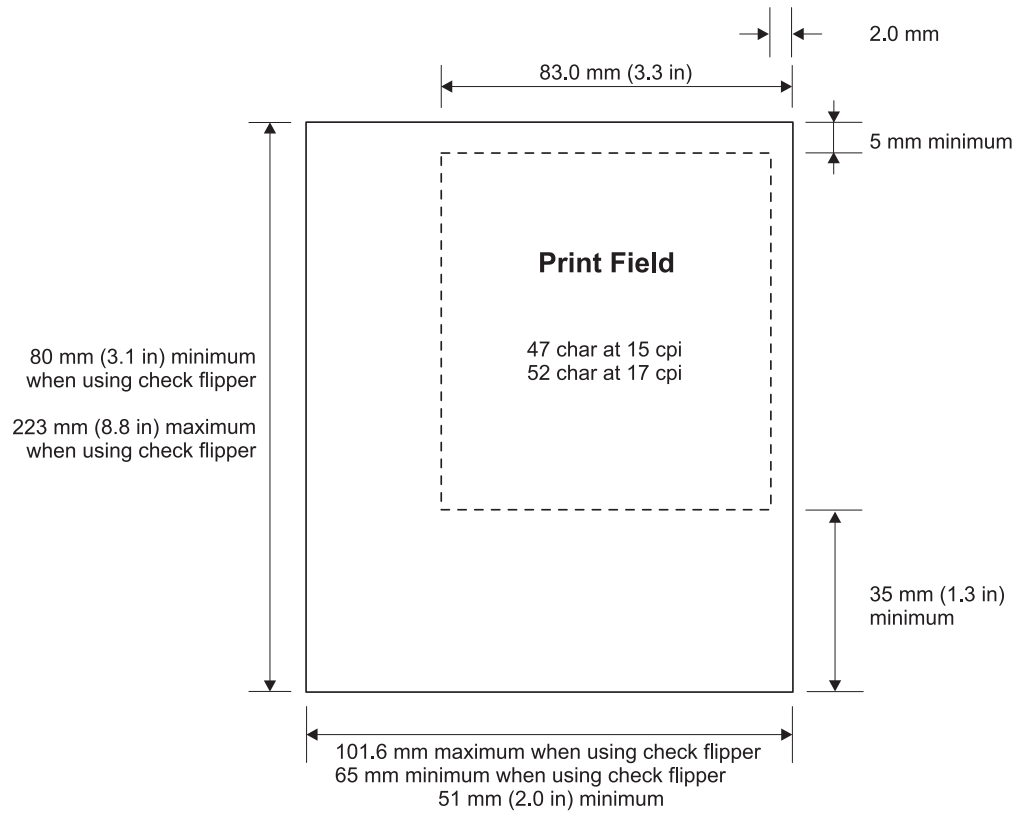

Figure 23. Printable area of an inserted document (portrait)

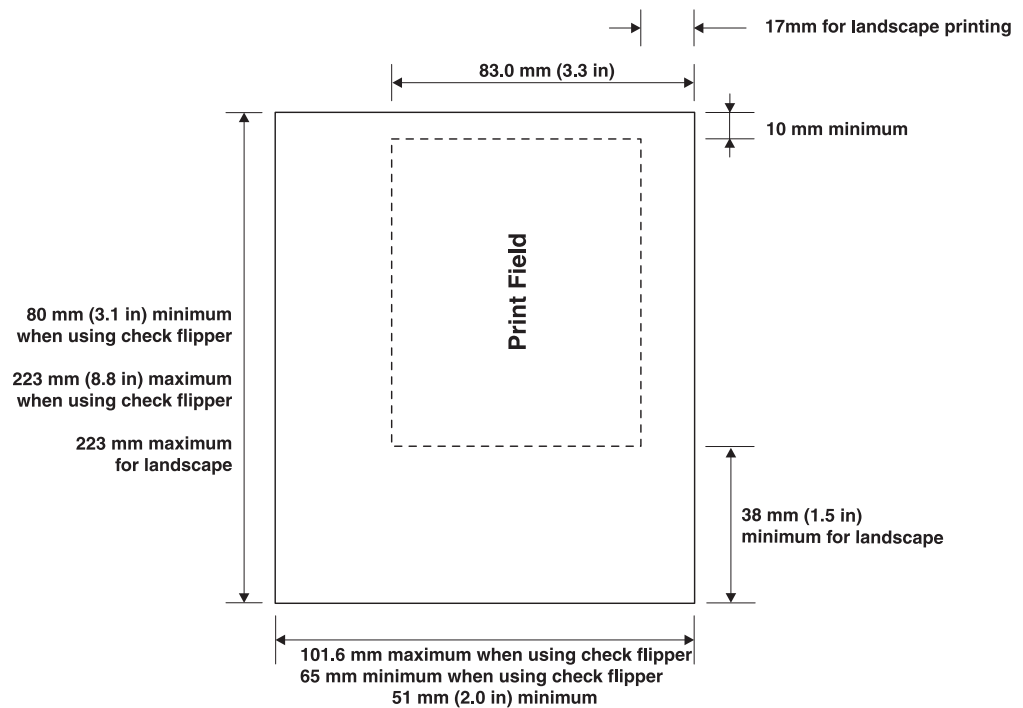

Figure 24. Printable area of an inserted document (landscape)

Ribbon loading

1. Open the ribbon cover. As the cover is opened, the print head moves to a position where you can easily load a ribbon.

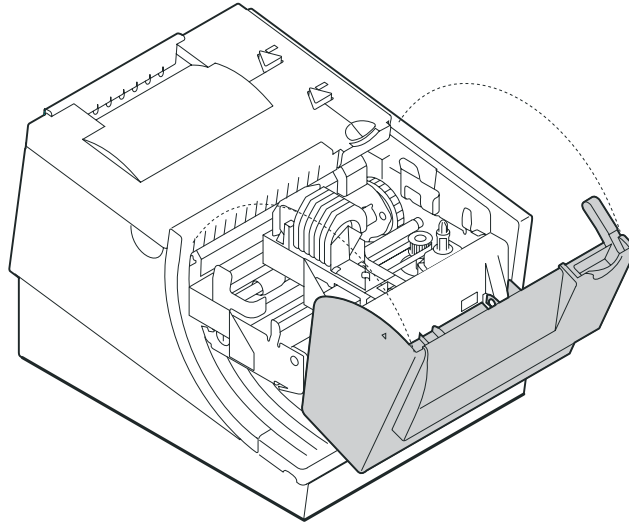

Figure 25. Opening the ribbon cover

2. If there is already a ribbon cartridge installed, remove it by lifting it straight up.

Note: You might need to grasp the body of the cartridge rather than the top to remove it.

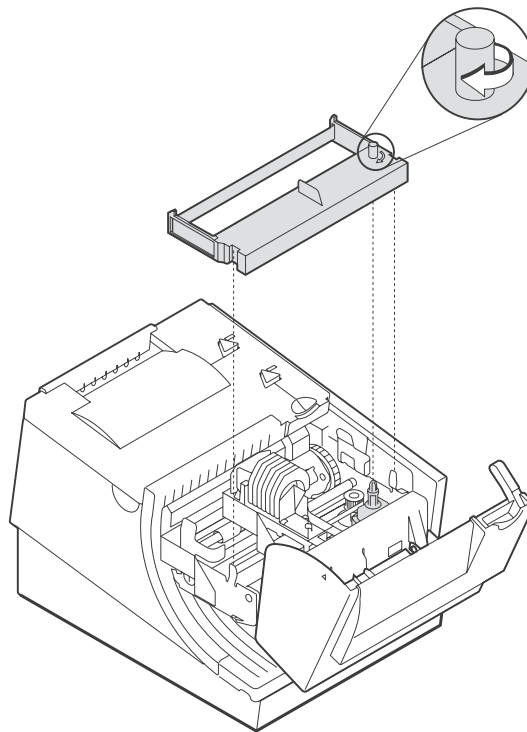

Figure 26. Ribbon cartridge loading

- Maintain ribbon tension by turning the ribbon cartridge knob as shown in Figure 26 on page 51. Lower the cartridge into position until the notches on its sides snap into place on the printer guides. Once the cartridge is in place, turn the knob until the ribbon slides into place between the print head and the ribbon shield. See Figure 27 for correct ribbon positioning.

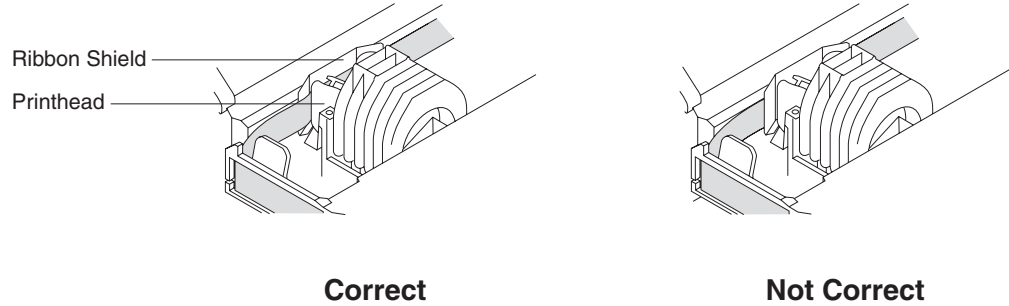

Figure 27. Ribbon path around the print head

- Close the ribbon cover.

Paper loading

1. Open the paper cover.
2. If there is any unused paper or if there is an empty paper roll core in the paper roll bucket inside the printer, remove it before inserting a new paper roll. You can throw the core in the trash can.

Note: Refer to the label on the inside of the paper cover for a diagram of how to load paper.

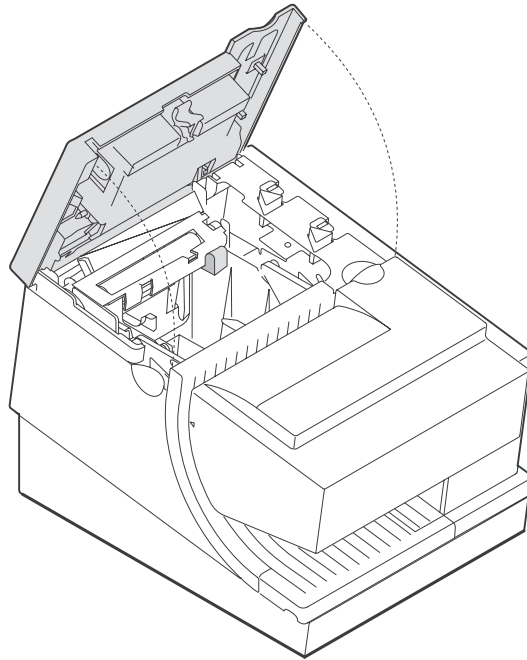

Figure 28. Paper cover (Models T11, T12, T13, T14, T18, T19, TG3, TG4, TG8, and TG9)

3. See Figure 29 on page 54 and place the paper roll into the paper roll bucket as shown. The leading edge of the paper should come from the direction of the front of the printer and go across the top of the roll as shown in the diagram. If it feeds from the bottom of the roll, nothing will be printed on the paper.

Note: The thermal print head will not print on paper with glue on it. If the new paper roll was sealed by glue, tear off the 6 to 8 inches of paper with glue on it before loading it.

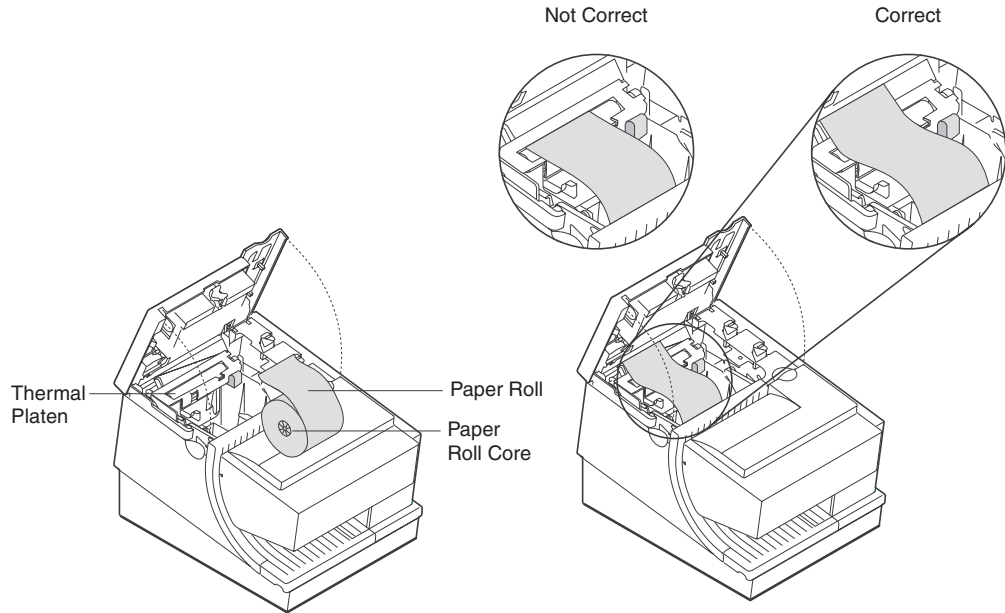

Figure 29. Paper loading path (Models T11, T12, T13, T14, T18, T19, TG3, TG4, TG8, and TG9)

4. See Figure 29. Place the leading edge of the paper over the metal guide.
5. Close the paper cover.
6. Press the customer receipt feed button to advance the paper, to verify that the paper is feeding correctly. Feed 30 cm (about 1 ft.) of paper through to test for correct alignment.

Attention: Do not pull the receipt paper out of the printer with the paper access cover closed. This disengages the paper feed. The paper feed motor must then catch up before the printer can feed the paper, which causes missing lines or partial lines of print. Use the customer receipt feed button to advance the receipt and all lines will print.

Clearing jams in the check flipper area

This procedure is for the SureMark printer Models T12, T14, T18, and T19 (MICR Reader and Check Flipper features) only.

If a check jams in the Check Flipper mechanism:

1. Lift up the left front corner of the lower document insert cover and pull the cover from the printer. (See Figure 30.)

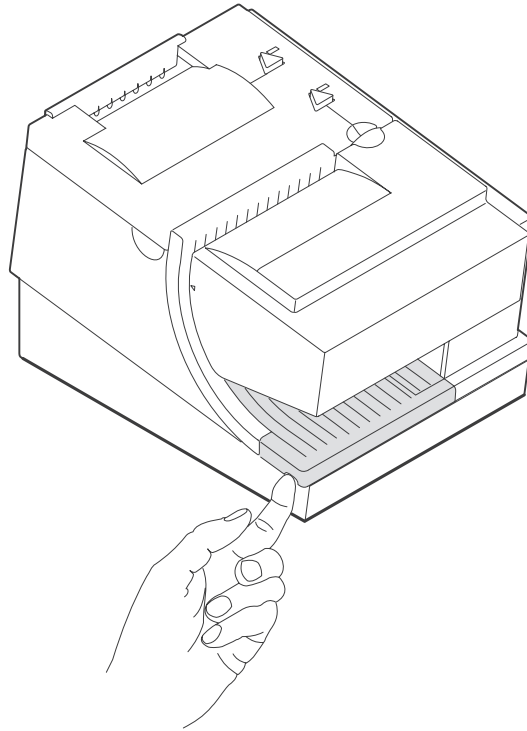

Figure 30. Removing the lower document insert cover

2. The action you take in this step depends on whether the document is visible and can be removed:
 - If you can remove the document:
 - a. Remove the document.
 - b. Replace the lower document insert cover.
 - c. You are finished with this procedure.
 - If you can not remove the document, continue with Step 3.
3. Lift up the tab on the left side of the check flipper cartridge and remove the assembly from the printer. (See Figure 31 on page 56.)

Note: For printers with a powered flipper (Models T18, T19, TG8, TG9) the cartridge is attached to the printer with an electrical cable and can not be removed. Simply raise the front edge of the cartridge to remove a jammed document underneath.

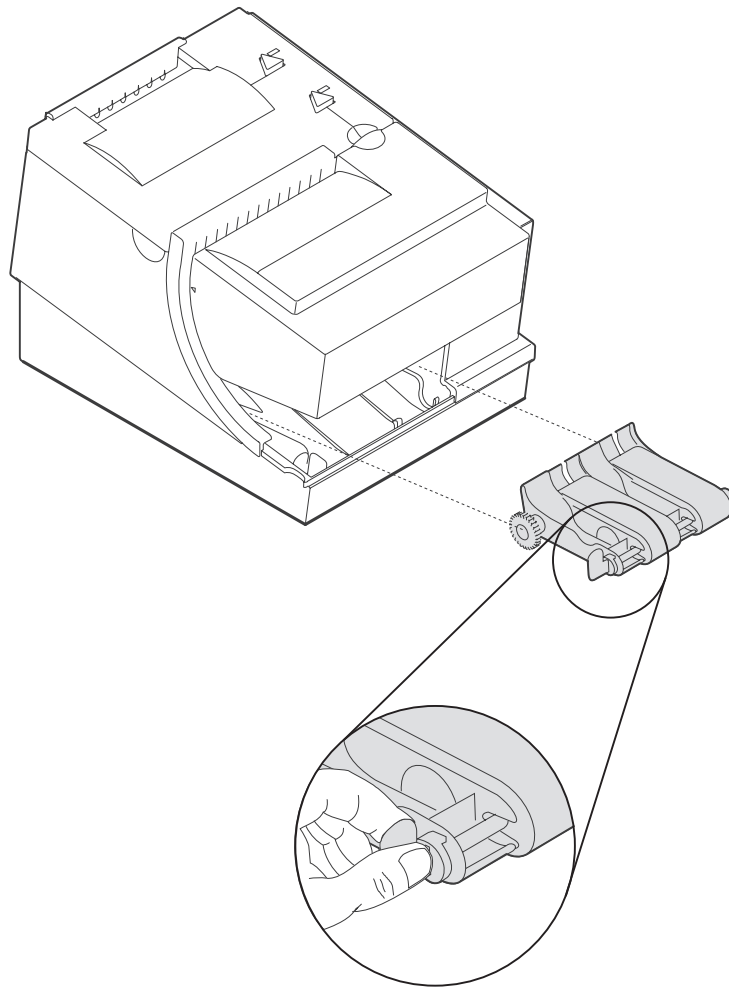

Figure 31. Removing the check flipper cartridge (except Models T18, T19)

4. Reach inside the document insert station and carefully remove the jammed check.
5. Reinstall the check flipper cartridge and the lower DI cover.

% MICR reader read head cleaning

% The MICR reader read head should be cleaned after 10000 checks are processed
% or every 3 months, as required.

1. Open the ribbon cover.
2. Move the impact printhead to its rightmost position.
3. Rotate the document sensor assembly towards the front of the printer to expose the MICR read head.
4. Use a cotton swab that is lightly soaked with alcohol to wipe any residue or dirt from the MICR read head surface.
5. Gently return the document sensor assembly to its original position.

%

%

MICR Read Head



Document Sensor Assembly

Figure 32. MICR reader read head

%
%
%

Thermal print head cleaning

The thermal print head can be cleaned whenever print quality deteriorates.

1. Open the paper cover.
2. Using a cotton swab soaked in isopropyl alcohol, gently wipe the print head several times on its print line and on the surrounding area. See Figure 33 on page 58.

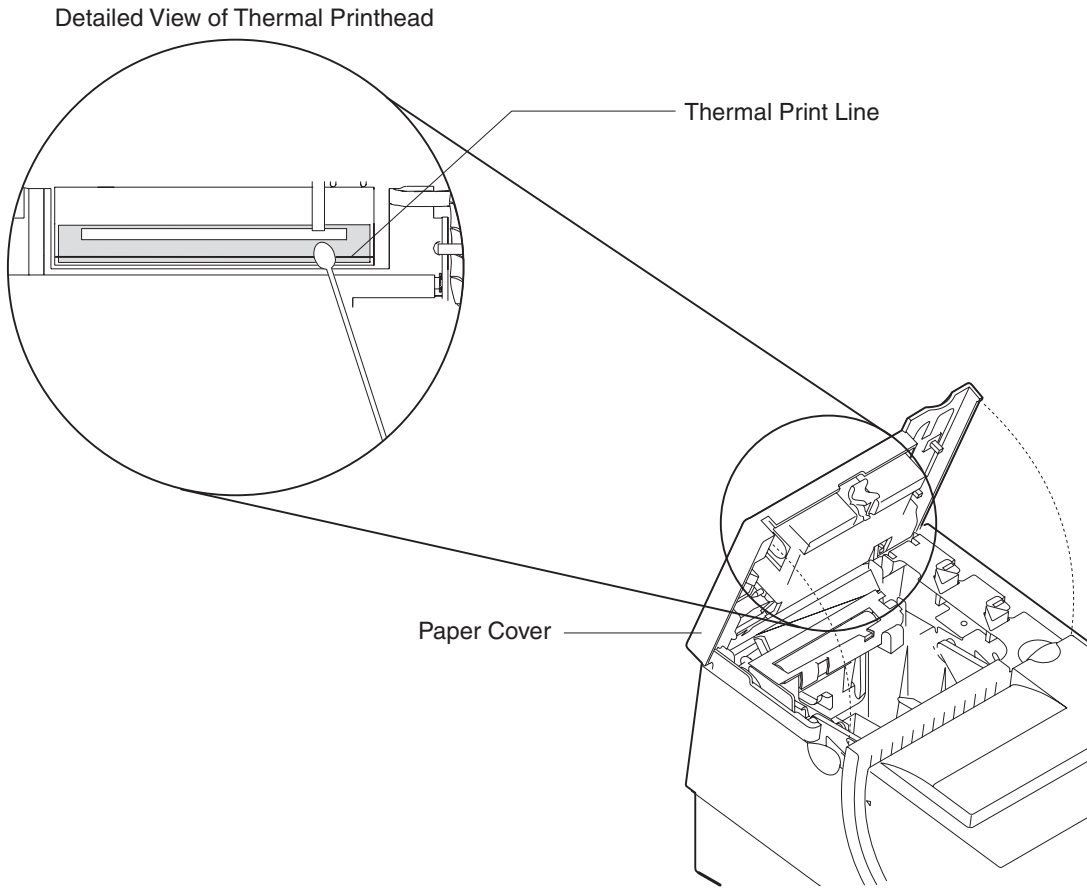

Figure 33. Print head and print line area (Models T11, T12, T13, T14, T18, T19, TG3, TG4, TG8, and TG9)

3. Wipe off any residual alcohol with a dry swab.

If print quality does not improve after cleaning the thermal print head, call for service.

Document scanner cleaning (Model T18, T19, TG8, TG9)

The scanner surface should be cleaned after 10 000 documents or every three months or whenever image quality deteriorates.

1. Open the ribbon cover. See Figure 34.

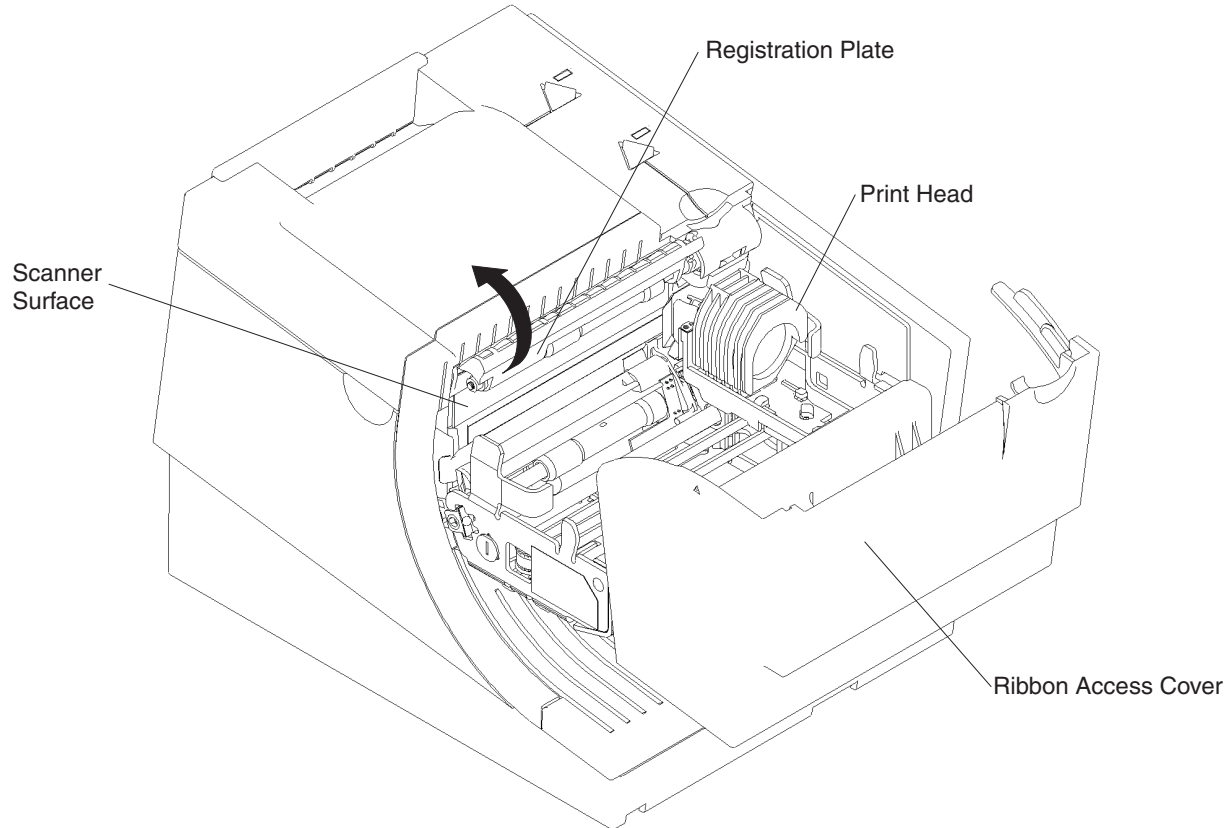

Figure 34. Scanner and print head location (Model T18, T19, TG8, TG9)

2. Move the impact print head to its rightmost position, as shown.
3. Rotate the scanner registration plate 180° up to expose the glass scanner surface. See Figure 34.
4. Use a cotton swab that is *lightly* soaked with alcohol to wipe any residue from the scanner glass surface.
5. Gently return the scanner registration plate to its original position.
6. The scanner should be recalibrated after it has been cleaned. See “Document scanner calibration (Models T18, T19, TG8, TG9)” on page 60.

Document scanner calibration (Models TI8, TI9, TG8, TG9)

The printer must have power ON. Use a clean sheet of white copier paper (not recycled paper) as the calibration target. Fold the paper in half. (Optional: cut paper to 4.25 in. wide.)

1. Always begin by making sure the scanner window is clean.
2. Put paper in the CR station (paper will be used for printing in later step).
3. Insert the target paper into the document insert station as you would insert a check. The folded edge should be up (or inserted first) and the right edge should be against the right side of the paper path. Press the DI button to automatically advance the paper to the ready position.
4. Enter offline mode by doing the following:
 - a. Open the CR cover and the DI cover.
 - b. Press and hold both buttons until the LED flashes rapidly.
 - c. Close the DI cover.
 - d. Close the CR cover.
5. Follow the directions that are printed in the CR station to perform the calibration.
6. Remove the target paper when complete.
7. Power the printer OFF and then ON for the changes to take effect.

Chapter 5. Testing and problem analysis



To avoid a shock hazard, do not connect or disconnect any cables or perform installation, maintenance, or reconfiguration of this product during an electrical storm.



To avoid shock hazard:

- The power cord must be connected to a properly wired and earthed receptacle.
- Any equipment to which this product will be attached must also be connected to properly wired receptacles.

Note: For translations of these safety notices, see *IBM Safety Information—Read This First, GA27-4004*.

Testing the printer

When you power ON the SureMark printer, it runs a power-on self-test (POST). If the POST finds no errors, the printer is ready for operation. Follow this procedure to determine if there are errors.

Note: Never connect or disconnect the printer when power is applied (when LEDs are ON).

1. If the printer is powered ON, power OFF the printer and power it ON again.
 - If the printer is attached to the system with the EIA-232 cable or the standard USB cable with a power brick, disconnect the power cord, then reconnect the power cord to a properly wired and grounded power source.
 - If the printer is attached to the system with the RS-485 cable, power OFF the POS system, and then power ON the system, which also powers ON the printer.
 - If the printer is attached to the system with a powered USB cable, the USB attached printer can be hot-plugged.

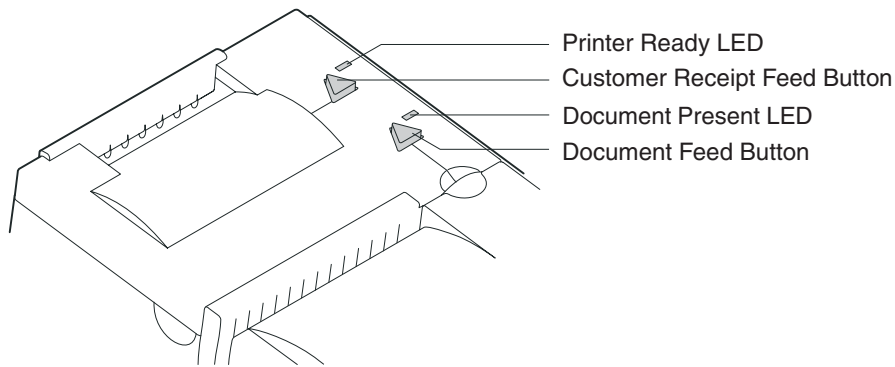

Figure 35. Printer buttons

2. Check the status of the Printer Ready indicator:
 - Printer ready indicator ON:**
The power-on self-test completed successfully.
 - Printer ready indicator OFF or blinking:**
The POST failed.
3. If the POST fails or if you suspect problems with your system, see “Problem determination” on page 67.
4. See “Offline tests” and run the offline tests. If the offline tests fail or you suspect problems with your system, see “Problem determination” on page 67.

Offline tests

The following offline tests are used as diagnostic tools to ensure the printer is operating correctly.

Customer receipt test

1. Press and hold both buttons to enter offline mode. When the printer ready indicator begins blinking, release both buttons.
2. Press and release the customer receipt feed button to start this test.
3. See Figure 36 on page 64 and verify that your printer has printed correct information for your model and configuration:
 - MICR reader enabled and check flipper enabled (Model T12, T14, T18, T19, TG4, TG8, TG9)
 - Optical scanner enabled (Model T18, T19, TG8, TG9)
 - Full check scan enabled (Model T19, TG9)
 - Double-byte character sets enabled (2 MB RPQ)
 - EIA-232 or RS-485 serial interface or USB interface
 - 2 MB card with user flash storage enabled (Model T13, T14, TG3, TG4)
 - 2 MB card in single-byte mode (2 MB RPQ)
 - Applicable parameters for EIA-232 communications:
 - Baud rate (9600, 19 200, or 115 200 bps)
 - DTR/DSR or XON/XOFF control
 - A solid line should appear as the last line of the test pattern.

If any characters that appear in Figure 36 on page 64 are missing from the test pattern that you print, or if the solid line is missing, go to “Problem determination” on page 67.

Document insert test

1. Insert a document in the document insert station. The document present indicator should come on.
 - If the document present indicator does not come on, realign the document.
 - If pressing the document feed button does not feed the document, go to “Problem determination” on page 67.
2. Press and hold both buttons to enter offline mode. When the printer ready indicator begins blinking, release both buttons.
3. Press and release the document feed button to print the test pattern. The test pattern includes all printable characters in the resident code page, printed in the default font.
4. See Figure 36 on page 64 and verify that your printer has printed correct information for your model and configuration:
 - MICR reader enabled and check flipper enabled (Model TI2, TI4, TI8, TI9, TG4, TG8, TG9)
 - Optical scanner enabled (Model TI8, TI9, TG8, TG9)
 - Full check scan enabled (Model TI9, TG9)
 - Double-byte character sets enabled (2 MB RPQ)
 - EIA-232 or RS-485 serial interface or USB interface
 - 2 MB card with user flash storage enabled (Model TI3, TI4, TG3, TG4)
 - 2 MB card in single-byte mode (2 MB RPQ)
 - Applicable parameters for EIA-232 communications:
 - Baud rate (9600, 19 200, or 115 200 bps)
 - DTR/DSR or XON/XOFF control
 - A solid line should appear as the last line of the test pattern.

If any characters that appear in Figure 36 on page 64 are missing from the test pattern that you print, or if the solid line is missing, go to “Problem determination” on page 67.

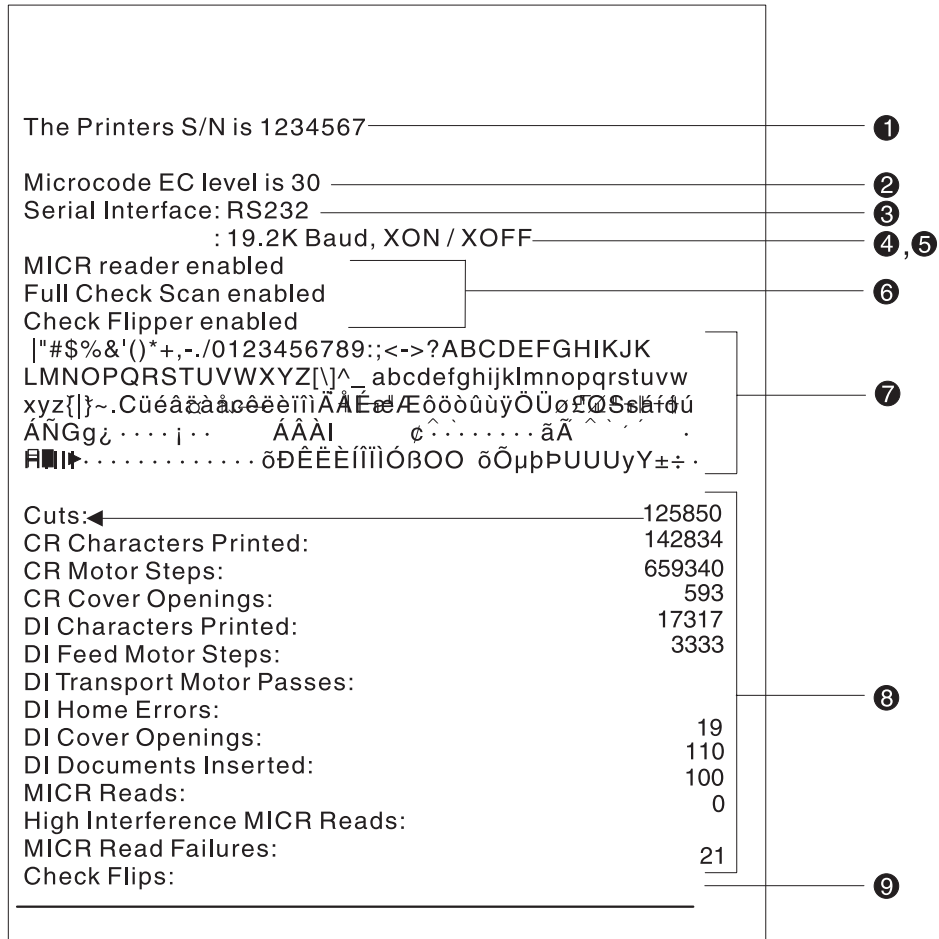

Figure 36. Offline printer test pattern from the customer receipt station (Models T11, T12, T13, T14, T18, T19, TG3, TG4, TG8, TG9)

Test Pattern Notes:

1. The serial number that prints will be the actual serial number of your printer.
2. The microcode level will be the actual level of your printer's microcode.
3. The serial interface will be specified as **EIA-232**, **RS-485**, or **USB**, depending on which interface is used to attach the printer to the system unit.
4. The line speed information appears only when the EIA-232 interface is used. The value can be either **9.6 Kbps** or **19.2 Kbps**, depending on the EIA-232 switch settings. See "EIA-232 communication mode selections (all models except T18, T19, TG8, TG9)" on page 28.
5. The EIA-232 control mode information appears only when the EIA-232 interface is used. The value can be either **DTR/DSR** or **XON/XOFF**, depending on the EIA-232 switch settings. See "EIA-232 communication mode selections (all models except T18, T19, TG8, TG9)" on page 28 or "EIA-232 communication mode selections (Models T18, T19, TG8, TG9)" on page 30.
6. The feature enabled lines will appear only when the feature is installed.
7. These lines break at different points for the test pattern printed in the document insert station.
8. This section contains printer usage statistics that you can use for problem determination.
9. The line across the bottom should be solid with no blank spaces.

MICR reader and check flipper test (Models TI2, TI4, TI8, TI9, TG4, TG8, and TG9 only)

Attention: Failure to perform these steps in the sequence shown will cause the entire electronic journal to print on the CR station. Printing the electronic journal erases the information from flash storage.

1. Insert the check face down with the magnetic ink characters to the right.
2. Press and hold both buttons to enter offline mode. When the printer ready indicator begins blinking, release both buttons.
3. Press and release both buttons again.
4. The printer will then perform a self-test of the MICR/flipper function.
5. Remove the check.

Characters that match the magnetic ink characters are printed on the customer receipt and the check is flipped over. Characters that can not be read will be replaced with question marks and will be printed at the customer receipt station. If the characters are not read properly or the check does not flip, go to “Problem determination” on page 67.

If the Model TI2, TI4, TI8, TI9, TG4, TG8, or TG9 detects noise, it prints a message on the customer receipt below the magnetic characters from the check (Figure 37 and Figure 39 on page 66 are examples; actual numbers may vary). The message shows noise characteristics. You can use the noise level to position your printer to minimize outside interference with the MICR reader. An acceptable noise level is less than 5 percent, if possible.

Sources of electromagnetic noise (for example, displays, security towers, and other sources) can interfere with the MICR reader read head. If the printer shows an external noise source, rearrange the printer to make the noise source as far away as possible from the right side of the printer. This may eliminate the external noise.

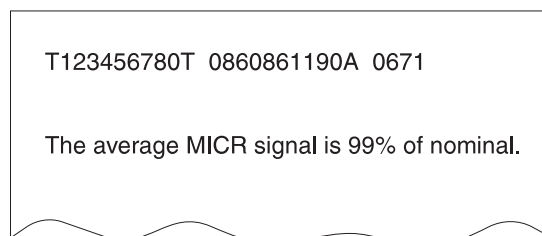

T123456780T 0860861190A 0671

The average MICR signal is 99% of nominal.

Figure 37. MICR reader test results (Models TI2, TI4, and TG4): Good noise level

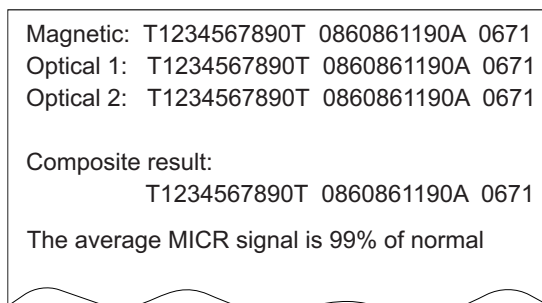

Magnetic: T1234567890T 0860861190A 0671
Optical 1: T1234567890T 0860861190A 0671
Optical 2: T1234567890T 0860861190A 0671

Composite result:
T1234567890T 0860861190A 0671

The average MICR signal is 99% of normal

Figure 38. MICR reader test results (Models TI8, TI9, TG8, TG9): Good noise level

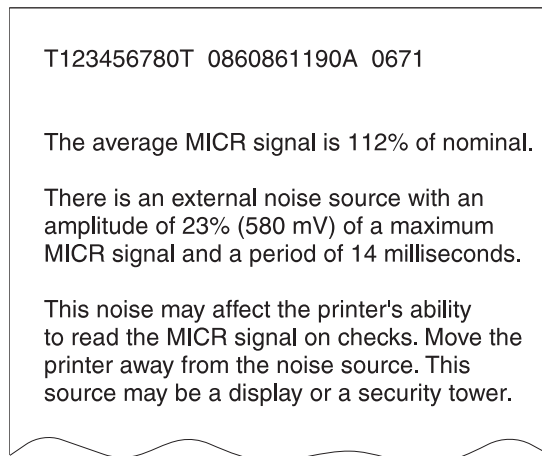

Figure 39. MICR reader test results: Noise level needs adjusting

Scanned check printout (Models T18, T19, TG8, TG9)

Following the description of the test, Models T18, T19, TG8, and TG9 also print a copy of the check that has been scanned. This printout is in black and white, not grayscale.

EIA-232 hex dump

To enable hex dump mode for the printer:

Power off the printer, press and hold the paper feed button and then power on the printer with the paper feed button still pressed.

To exit, power OFF or reset the printer.

Resetting the printer - offline

1. Press and hold both buttons (Customer Receipt Feed button and Document Feed button) to enter offline mode.
2. Release both buttons when the Printer Ready indicator begins to blink.
3. Open the customer receipt cover, then close it. The printer resets.

Electronic journal dump

Note: Electronic journal data must be formatted and stored as printed lines for the journal data to be printed in readable format.

1. Press and hold both buttons (Customer Receipt Feed button and Document Feed button) to enter offline mode.
2. Release both buttons when the Printer Ready indicator begins to blink.
3. Press and release both buttons.

Problem determination

Any problems that arise with a SureMark printer are either software errors or hardware failures. This section contains information to help you determine the cause of a problem and how to solve it.

If the SureMark printer fails, use Table 3 to identify and report the problem. Follow the procedures described in the table. If you can not identify and solve the problem, call your service representative.

Table 3. Troubleshooting (Models T11, T12, T13, T14, T18, T19, TG3, TG4, TG8, and TG9)

If the problem is...	Then do this...
Printer ready indicator is OFF.	<ul style="list-style-type: none"> • If connected to a system using the RS-485 communication port, check that the system is powered ON and cable 7 is connected. • If using the EIA-232 communication port or a USB port with a power brick, check that the brick power supply is connected to the printer and plugged into an ac power source. • If using USB communication with a powered USB cable, check that the system is powered ON.
Printer ready indicator is blinking.	<ul style="list-style-type: none"> • Check that the customer receipt station has paper loaded correctly. Close the cover and push the Customer Receipt Feed button to feed a small amount of paper. • Check the document insert station print head and paper path for any obstructions. • Check that the paper and ribbon covers are closed.
Checks not flipping	Go to “Clearing jams in the check flipper area” on page 55.
Checks not reading	Go to “MICR reader read head cleaning” on page 56 or “Document scanner cleaning (Model T18, T19, TG8, TG9)” on page 59 or “Document scanner calibration (Models T18, T19, TG8, TG9)” on page 60.
Customer receipt station is feeding paper, but is not printing.	<ul style="list-style-type: none"> • Ensure that the paper roll is not upside down. Go to “Paper loading” on page 53. • Clean the print head. See “Thermal print head cleaning” on page 57.
Document insert station is not printing	<ul style="list-style-type: none"> • Check the paper path. • Check to see if the ribbon is installed correctly. • Change the ribbon, go to “Ribbon loading” on page 51.
Scanned images streaked, too light, or too dark	<ul style="list-style-type: none"> • Clean the scanner window. Go to “Document scanner cleaning (Model T18, T19, TG8, TG9)” on page 59. • Calibrate the scanner. Go to “Document scanner calibration (Models T18, T19, TG8, TG9)” on page 60 • Clean or replace the registration plate.

Notes:

1. Record all symptoms before calling for service.
2. If you receive software error messages, refer to the application program’s software manual.
3. Call your service representative.

Part 3. Models TF6 and TM6

This part contains operational, testing, and problem determination information for SureMark printer Models TF6 and TM6.

Chapter 6. Operation (Models TF6 and TM6)

Operating controls and indicators	71
Paper loading	71
Thermal print head cleaning	73

Note: All covers *must* be installed on the SureMark printer during operation.

Operating controls and indicators

There is one triangular-shaped button and one LED indicator located on top of the printer.

When the LED indicator is on continuously, the printer is powered ON and ready for printing. When the indicator blinks, one of the following conditions exists:

- The printer is offline (offline testing is enabled).
- The printer is out of paper.
- The cover is open.
- The cutter is jammed.

See “Offline test” on page 76 for additional button functions.

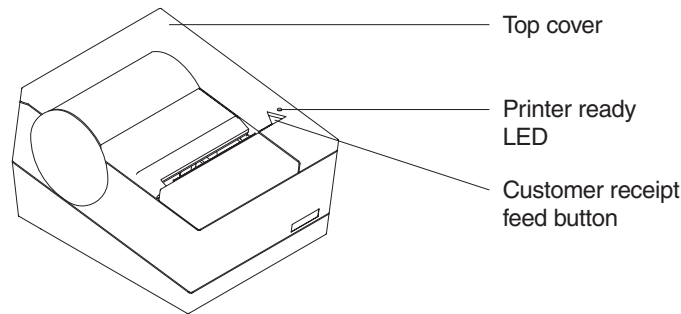

Figure 40. SureMark printer indicator, control, and printing station (Models TF6 and TM6)

Paper loading

1. Open the paper cover.
2. If there is any unused paper or if there is an empty paper roll core in the paper roll holder inside the printer, remove it before inserting a new paper roll. You can throw the core in the trash can.
3. Drop the roll into the bucket. The leading edge of the paper should come from the direction of the back of the printer and go across the bottom of the roll as shown in the diagram. See Figure 41 on page 72.

Note: The thermal print head will not print on paper with glue on it. If the new paper roll was sealed by glue, tear off the 15 to 20 cm (6 to 8 in.) of paper with glue on it before loading it.

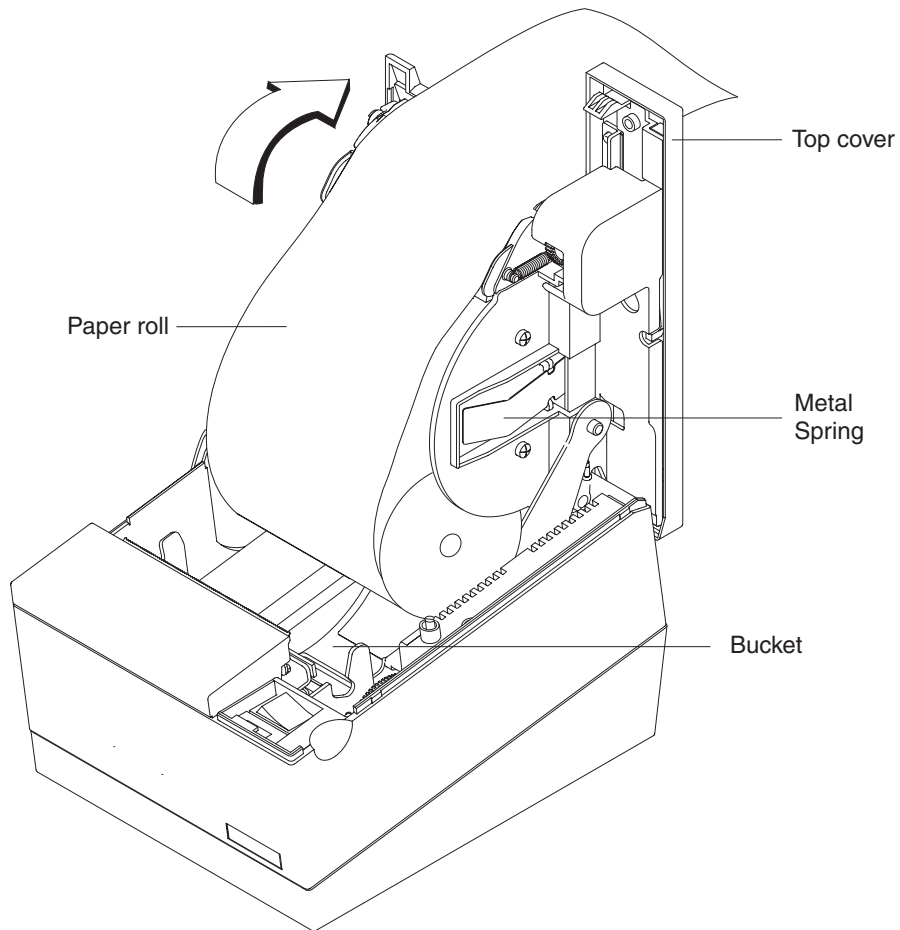

Figure 41. Paper loading path (Models TF6 and TM6)

4. Pull the end of the paper up over the paper roll and toward the back of the printer.

Note: Refer to the label on the inside of the bottom cover for a diagram of how to load paper.

5. Close the paper cover.
6. Press the customer receipt feed button to advance the paper and verify that the paper is feeding correctly. Feed 30 cm (about 1 ft) of paper through to test for correct alignment.

Attention: Do not pull the receipt paper out of the printer with the paper access cover closed. This might cause partial lines of print. Use the customer receipt feed button to advance the receipt.

Thermal print head cleaning

The thermal print head can be cleaned whenever print quality deteriorates.

1. Open the paper cover.
2. Using a cotton swab soaked in isopropyl alcohol, gently wipe the print head several times on its print line and on the surrounding area. See Figure 42.
3. Wipe off any residual alcohol with a dry swab.

If print quality does not improve after cleaning the thermal print head, call for service.

Detail View of Thermal Print Head

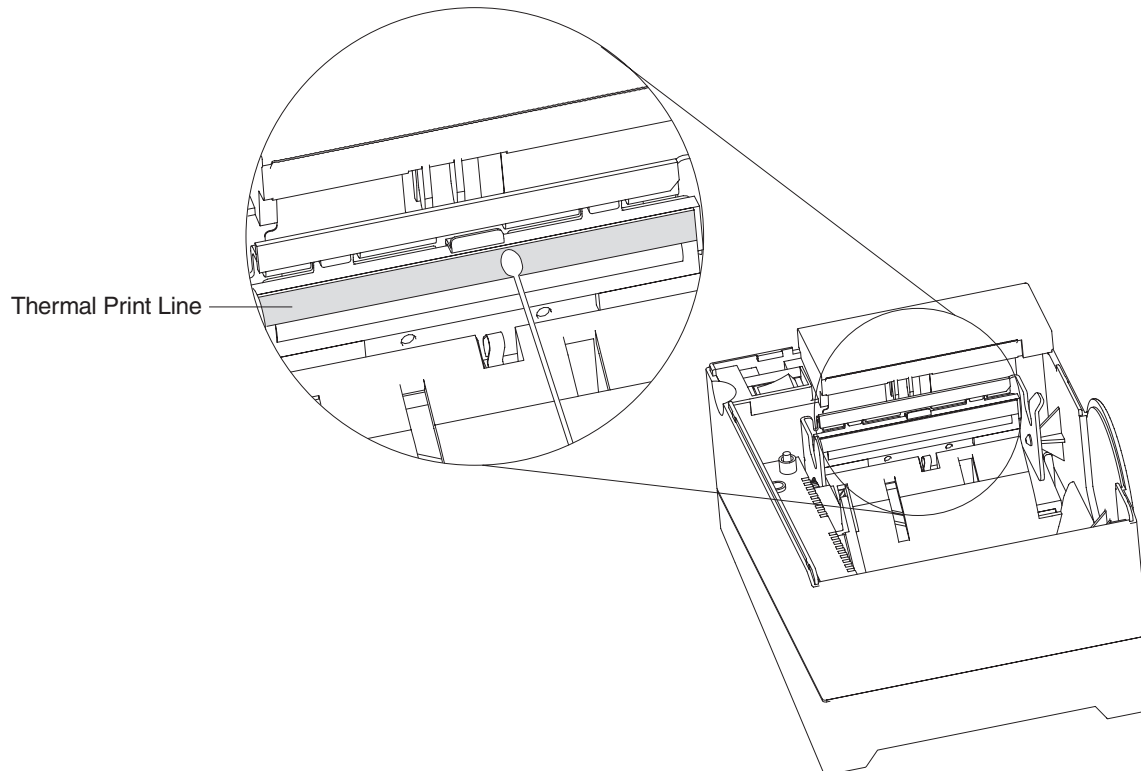

Figure 42. Print head and print line area (Models TF6 and TM6)

Chapter 7. Testing and problem analysis (Models TF6 and TM6)

Testing the printer	75
Offline test	76
EIA-232 hex dump	77
Resetting the printer - offline	78
Problem determination	78



To avoid a shock hazard, do not connect or disconnect any cables or perform installation, maintenance, or reconfiguration of this product during an electrical storm.



To avoid shock hazard:

- The power cord must be connected to a properly wired and earthed receptacle.
- Any equipment to which this product will be attached must also be connected to properly wired receptacles.

Note: For translations of these safety notices, see *IBM Safety Information—Read This First, GA27-4004*.

Testing the printer

When you power on the SureMark printer, it runs a power-on self-test (POST). If the POST finds no errors, the printer is ready for operation. Follow this procedure to determine if there are errors.

Note: Never connect or disconnect the printer when power is applied (when the LED is on).

1. If the printer is powered on, power OFF the printer and power it on again.
 - If the printer is attached to the system with the EIA-232 cable or the standard USB cable with a power brick, disconnect the power cord, then reconnect the power cord to a properly wired and grounded power source.
 - If the printer is attached to the system with the RS-485 cable, power OFF the POS system, and then power on the system, which also powers on the printer.
 - If the printer is attached to the system with a powered USB cable, the USB attached printer can be hot-plugged.
 - For single-station printers, use the printer's power ON/OFF switch that is located under the top cover. Power OFF the printer, then power ON the printer.

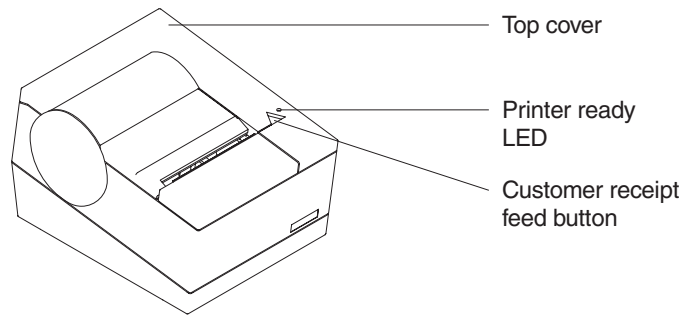

2. Check the status of the Printer Ready indicator:

Printer Ready indicator ON:

The POST completed successfully.

Printer Ready indicator OFF or blinking:

The POST failed.

3. If the POST fails or if you suspect problems with your system, see “Problem determination” on page 78.
4. See “Offline test” and run the offline test. If the offline test fails or you suspect problems with your system, see “Problem determination” on page 78.

Offline test

An offline printing test is provided as a diagnostic tool to ensure the printer is operating correctly.

1. Open the top cover.
2. Press and hold the paper feed button for 5 seconds. The LED indicator will make one quick flash followed by a pause. The beeper will make a short single tone periodically.

Note: The paper feed button is the small button next to the LED.

3. Release the paper feed button.
4. Close the top cover.
5. See Figure 43 on page 77 and verify that your printer has printed correct information for your model and configuration:
 - 2 MB card with user flash storage enabled
 - EIA-232, RS-485, or USB serial interface
 - Applicable parameters for EIA-232 communications:
 - Baud rate (9600 or 19 200 bps)
 - DTR/DSR or XON/XOFF control
 - A solid line should appear as the last line of the test pattern.

If any characters that appear in Figure 43 on page 77 are missing from the test pattern you print, or if the solid line is missing, go to Table 4 on page 78.

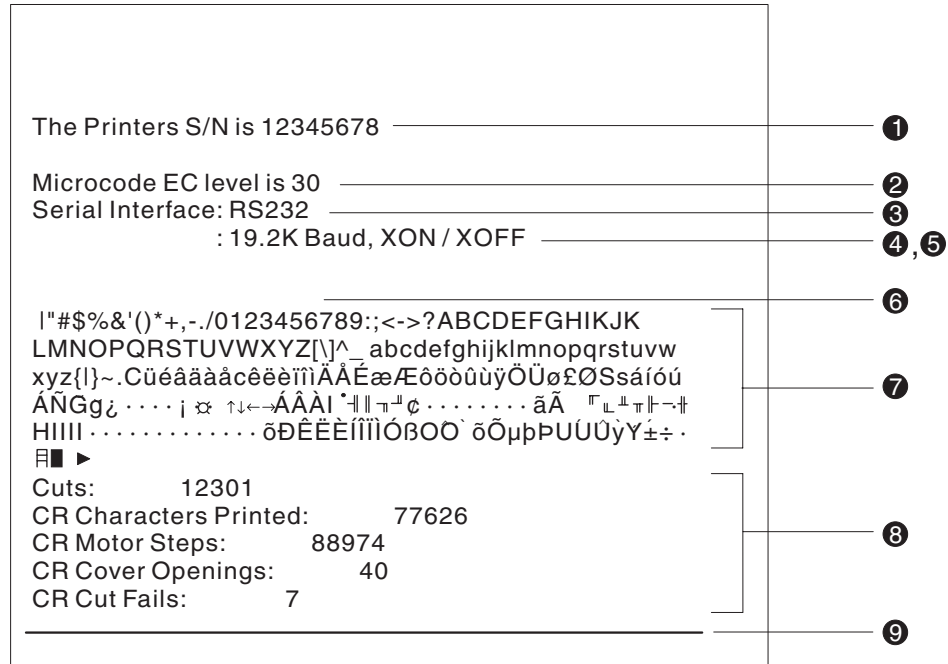

Figure 43. Offline printer test pattern (Models TF6 and TM6)

Test Pattern Notes:

1. The serial number that prints will be the actual serial number of your printer. (If the logic card has been replaced, this number must be reset to the original serial number.)
2. The microcode level will be the actual level of your printer’s microcode.
3. The serial interface will be specified as **EIA-232**, **RS-485**, or **USB**, depending on which interface is used to attach the printer to the system unit.
4. The line speed information appears only when the EIA-232 interface is used. The value can be either **9.6 K Baud** or **19.2 K Baud**, depending on the EIA-232 switch settings. See “EIA-232 communication mode selections (all models except T18, T19, TG8, TG9)” on page 28.
5. The EIA-232 control mode information appears only when the EIA-232 interface is used. The value can be either **DTR/DSR** or **XON/XOFF**, depending on the EIA-232 switch settings. See “EIA-232 communication mode selections (all models except T18, T19, TG8, TG9)” on page 28.
6. The feature-enabled lines will appear only when a feature is installed.
7. This section contains the test pattern.
8. This section contains printer usage statistics that you can use for problem determination.
9. The line across the bottom should be solid with no blank spaces.

EIA-232 hex dump

An EIA-232 hex dump is provided to help diagnose problems with Models TM6 and TF6.

To enable hex dump mode for the Model TF6 or TM6 printer:

Power off the printer, press and hold the paper feed button and then power on the printer with the paper feed button still pressed.

To exit, power OFF or reset the printer.

Resetting the printer - offline

To reset the printer:

1. Open the top cover.
2. Power off the printer using the power ON/OFF switch that is located in the right front corner of the printer.
3. Power on the printer.

Problem determination

Any problems that arise with a SureMark printer are either software errors or hardware failures. This section contains information to help you determine the cause of a problem and how to solve it.

If the SureMark printer fails, use Table 4 to identify and report the problem. Follow the procedures described in the table. If you can not identify and solve the problem, call your service representative.

Table 4. Troubleshooting (Models TF6 and TM6)

If the problem is...	Then do this...
Printer ready indicator is OFF.	<ul style="list-style-type: none"> • Check that the printer power switch, which is located under the top cover, is set ON. • If connected to a system using the RS-485 communication port, check that the system is powered on and cable 7 is connected. • If using the EIA-232 communication port or a USB port with a power brick, check that the brick power supply is connected to the printer and plugged into an ac power source. • If using USB communication with a powered USB cable, check that the system is powered ON.
Printer ready indicator is blinking.	<ul style="list-style-type: none"> • Check that the customer receipt station has paper loaded correctly. Close the cover and push the Customer Receipt Feed button to feed a small amount of paper. • Check that the cover is closed.
Customer receipt station is feeding paper, but is not printing.	<ul style="list-style-type: none"> • Ensure that the paper roll is in correctly. Go to "Paper loading" on page 53. • Clean the print head. See "Thermal print head cleaning" on page 57.

Notes:

1. Record all symptoms before calling for service.
2. If you receive software error messages, refer to the application program's software manual.
3. Call your service representative.

Updated April 2, 2009

Part 4. Appendixes

Appendix A. Consumable supplies

Paper specifications	81
Thermal paper	81
Document insert forms (Models TI1, TI2, TI3, TI4, TI8, TI9, TG3, TG4, TG8, and TG9 only)	82
Single and multipart form specifications	82
Specifications for documents that can be flipped	82
Print ribbons (Models TI1, TI2, TI3, TI4, TI8, TI9, TG3, TG4, TG8, and TG9 only)	83
Expendable supplies	83

%

Paper specifications

Attention: Using an inferior grade of paper can affect print quality as well as the life of print heads and the printer mechanism. See “Resources on the Internet” on page 44 for information about OEM paper recommended for SureMark printers.

Note: When selecting a paper, ensure that the paper’s archive life meets the requirements of the tax authorities of your country for archiving tax-related data.

Thermal paper

The paper used in the thermal receipt station must meet the following requirements:

Width 79.5 ± 0.5 mm (3.13 ± 0.02 in.)

Outside Diameter

80 mm (3.15 in.) maximum for thermal/impact SureMark printers

90 mm (3.54 in.) maximum for single-station SureMark printers

Thickness

0.0457–0.094 mm (0.0018–0.0037 in.) operating thickness range

Important

Paper has a significant manufacturing tolerance and nominal paper designations do not reflect actual measurements. The manufacturing tolerance must fall within the published operating thickness range. IBM strongly recommends that customers test paper in their specific configuration before use. The intent of this specification is that if any spot measurement of the paper is outside the specified range, the paper is deemed not to meet the specification and the customer is responsible for any problems caused by paper jams.

Weight

60 ± 19 g/m² (16 ± 5 lb)

The paper must be wound with the printing side facing out and with the outer edge glued to prevent unraveling. The paper should not be attached to the core in any manner. There should be 1.5 to 2.1 m (5 to 7 ft.) of red stripe at the end of the roll.

Note: Non-topcoated thermal paper can be recycled along with other paper products. They can also be incinerated and sent to landfills with no more effect on the environment than regular office paper waste.

Important

Printer reliability and performance are directly related to the quality of the supplies used by the customer. The published parameters for printer performance are established using supplies that meet the specifications listed above.

Thermal paper with post-processing, such as (but not limited to) watermarks, coupons, or advertisements printed on the front or back of the paper, is not covered by IBM specifications. Some inks and printing processes will work acceptably, while others will not. Printer problems that are caused by supplies that do not meet IBM specifications may result in a billable service call, regardless of the existence of a service contract.

Document insert forms (Models TI1, TI2, TI3, TI4, TI8, TI9, TG3, TG4, TG8, and TG9 only)

The printers will accommodate single and multipart forms.

Single and multipart form specifications

Specification	Value
Minimum width:	50 mm (2 in.)
Maximum thickness of multipart forms:	0.47 mm (0.0185 in.)
Maximum thickness of front sheet, multipart forms:	0.08 mm (0.003 in.)
Minimum thickness of single-part form:	0.10 mm (0.004 in.)
Maximum thickness of single-part form:	0.2 mm (0.008 in.)
Weight range for single-part forms:	68–90 g/m ² (18–24 #)
For best reliability, paper grain should be in the direction that the paper is fed into the printer.	

Notes:

1. Test all forms in the printer to ensure acceptable performance prior to buying a significant quantity. There should be no binding holes or other holes within 10 mm (0.4 in.) from the right edge of the form.
2. Forms less than 0.15 mm (0.006 in.) thick with the grain of the paper perpendicular to the feed direction (short-grain paper) should not be used for landscape printing.

Specifications for documents that can be flipped

Multipart forms and short-grain single-part forms are not supported.

Specification	Value
Minimum form length:	80 mm (3.14 in.)
Maximum form length:	223 mm (8.78 in.)
Maximum form width:	102 mm (4 in.)
Paper weight:	75–95 g/m ²

Print ribbons (Models T11, T12, T13, T14, T18, T19, TG3, TG4, TG8, and TG9 only)

The ribbon is an Epson ERC-35 or equivalent. In addition to the Epson ERC-35, the Infotech RE35P ribbon was tested and approved for use in the SureMark printer.

The Infotech ribbon, order number RE35P, Black, is available from:

Infotech, Inc.
2215 29th Street SE #B-1
Grand Rapids, MI 49508
Phone: (616) 452-5444
Fax: (616) 452-5499

Attention: Using an inferior grade of ribbon can affect print quality and the life of print heads and the printer mechanism.

% Expendable supplies

- % See "Resources on the Internet" on page 44 for information about OEM paper certifications for the SureMark printers.
- %
- % • Paper for the printer, order P/N locally
 - % • Q-Tip/Cotton Swab, P/N 69X7671

Appendix B. Printer maintenance procedures

Note: Power OFF all system components and unplug all power cables prior to cleaning.

% Product care procedures

% Owners and users should periodically inspect their system unit and its components for cleanliness and perform the following procedures based on usage and environmental characteristics.

- % 1. Clean the cover for cosmetic purposes as required.
- % • IBM suggests the use of a soft clean cloth with warm soapy water for cleaning the plastic parts on IBM product
 - % • Don't use abrasives or any alkaline, ammonia, or chloride-based cleaner.

% **Note:** Do not apply cleaning solution directly to the cover. Always apply the cleaner on a clean cloth and then wipe the cover with the damp cloth. Be certain that the cloth is only damp and not dripping wet.

- % 2. MICR Reader Read Head Cleaning as required.
- % • The MICR reader read head should be cleaned after 10 000 checks are processed or every 3 months. See "MICR reader read head cleaning" on page 56.
- % 3. Document scanner cleaning as required. (Model TI8, TI9, TG8, TG9 only.) See "Document scanner cleaning (Model TI8, TI9, TG8, TG9)" on page 59.
- % 4. Thermal Printhead Cleaning as required.
- % The thermal printhead can be cleaned whenever print quality deteriorates.
- % a. Open the paper cover.
 - % b. Using a cotton swab soaked in isopropyl alcohol, gently wipe the printhead several times on its print line and on the surrounding area. (See Figure 33 on page 58 for more details.)
 - % c. Wipe off any residual alcohol with a dry swab.
- % If the print quality does not improve after cleaning the thermal printhead, call for Service.
-

Service provider system maintenance procedures

Preventive Maintenance Scheduling

The following procedures can be performed during normal service call routines:

Models TI1, TI2, TI3, TI4, TI8, TI9, TG3, TG4, TG8, and TG9

- Clean the dust and debris from the paper cover and ribbon cover areas.
- If the printer has a check flipper, clean dust and debris from the area under the flipper cover and the flipper cartridge.
- Check the document scanner for dust and dirt (Models TI8, TI9, TG8, TG9 only).

Models TF6 and TM6

- Clean the dust and debris from the top cover area.

Appendix C. Technical information

General description	87
Specifications	87
Memory units	89
Immediate commands	89
Voltage conversion circuitry	89
RS-485 serial I/O parameters	90
Cash drawer connector pin assignments	90
EIA-232 connector pin assignments	91
EIA-232 parameters	91
USB connector pin assignments	92
Code page definitions	92
Generic code page	93
Code page 437	94
Code page 858	95
Code page 860	96
Code page 863	97
Code page 865	98
Character fonts	98
Thermal printing font	98
Impact printing fonts (Models TI1, TI2, TI3, TI4, TI8, TI9, TG3, TG4, TG8, and TG9)	99

General description

All SureMark printers print the customer receipt using the thermal print head. For SureMark printers that include a document insert station, documents are printed using the impact head.

Thermal printing occurs by placing a heating element against a thermally sensitive paper. By energizing the elements, dots are formed. Thermal printers print dot rows horizontally across the page; 576 dots make up a single dot row across the paper. Printing continues row by row until the entire character is formed.

Impact printing utilizes a standard ballistic print head. Each wire is fired against an inked ribbon which places a dot on the paper.

SureMark printers contain all the circuitry, processing hardware, and software for operating a thermal and, except for Models TF6 and TM6, an impact printer mechanism. SureMark printers do not contain a power supply. However, they do contain voltage conversion circuitry to allow connection to a standard IBM system interface or to an EIA-232 24 V power supply. (See “Power requirements” on page 12 for specific power supply specifications.)

Specifications

The information in the Document Insert Station column of Table 5 on page 88 applies only to SureMark Models TI1, TI2, TI3, TI4, TI8, TI9, TG3, TG4, TG8, and TG9. There is no document insert station on Models TF6 and TM6.

Table 5. Station characteristics

Characteristic	Customer Receipt Station	Document Insert Station
Speed (see note following table)	Models T11 and T12: 19.6 lps at 6 lpi, 26 lps at 8 lpi Models T13/T14/T18/T19/TG3/TG4/TG8/TG9: 39.2 lps at 6 lpi, 52 lps at 8 lpi; Models TF6 and TM6: 39.2 lps at 6 lpi, 52 lps at 8 lpi	4.3 lps
Paper Width	All models: 80 mm (3.54 in.)	
Print Width	All SureMark printers: 34 characters at 12 cpi, 44 characters at 15 cpi, 48 characters at 17 cpi All models except T11 and T12: 57 characters at 20 cpi	37 characters at 12 cpi, 47 characters at 15 cpi, 52 characters at 17 cpi.
Pitch	All SureMark printers: 12, 15, 17 cpi All models except T11 and T12: 20 cpi	12, 15, 17 cpi

Note: In order to conserve power, SureMark Models T13, T14, T18, T19, TG3, TG4, TG8, TG9, TF6 and TM6 reduce their throughput when printing high print densities, such as logo messages or full black lines. Because these types of print messages are used on a limited basis, the overall performance when printing a customer receipt is not noticeably affected.

The reduced print speed is based on the number of print dots that are turned on for a given print line, which is defined as dot utilization. Dot utilization is typically low for normal character printing and up to 100% for full black line printing. The SureMark printer operates at 52 lps at low dot utilization, and at slower speeds as the dot utilization increases.

Table 6. Sound characteristics

Type	Description	LwAd		LpAm		<LpA>m	
		Operating (bels)	Idling (bels)	Operating (dB)	Idling (dB)	Operating (dB)	Idling (dB)
SureMark T11	Printer	5.7	N/A	61.5	N/A	47	N/A

Notes:

LwAd The declared upper limit of the sound power level for a random sample of machines.

LpAm The mean value of the A-weighted sound pressure levels at the operator position (if any) for a random sample of machines.

<LpA>m

The mean value of the A-weighted sound pressure levels at the one-meter (bystander) positions for a random sample of machines.

N/A Indicates *not applicable*.

All measurements were made in accordance with ISO 7779 and reported in conformance with ISO 9296.

Memory units

Random access memory (RAM) is used for storing the image data for the thermal print head and program code. It is also used for storing incoming data from the communication port.

Flash memory is used for many purposes, including:

- Character set storage (80 KB)
- Personalized message storage (8 KB)
- Logo or APA message storage (64 KB)
- Flash memory data storage (104 KB on standard printers, 1.9 MB on printers with the 2 MB memory option, 8 MB on printers with the 8 MB memory option)
- Program code and resident character sets (256 KB) (except Models TI8 and TI9)
- For Models TI8 and TI9, 1.25 MB is available for all uses.

Personalized messages are those messages that are printed on each receipt in a POS environment. Storing these messages in the flash memory greatly reduces the data transmission time to the printer and the processing time of that data by the microprocessor. This is also true of graphics or APA messages, which require a significant amount of transmission and processing time.

Flash memory can also be used as a storage place for customer data. This data could be journal data.

Immediate commands

The SureMark printer has 4 KB of memory on Models TI1 and TI2, and 16 KB of memory on Models TI3, TI4, TI8, TI9, TG3, TG4, TG8, TG9, TF6, and TM6 to store incoming commands and data.

Most commands are received and then executed sequentially. However, several commands execute immediately upon receipt. These commands are:

- “Download graphics (logo) commands” on page 115
- “Predefine messages” on page 117
- “Download user-defined characters” on page 118
- “Extended address command-request printer ID” on page 112
- “Real-time requests” on page 175.

Voltage conversion circuitry

The printer requires two voltages. The print heads and motors use +24 V dc. Powering the logic circuitry requires +5 V dc. Printer input voltage is one of the following:

Communication Mode	Power Requirement
RS-485	+38 V dc and +5 V dc
EIA-232	+24 V dc
USB	+24 V dc

In each case, a single dc-to-dc converter converts voltage to +24 V dc and +5 V dc. An auto-switch circuit on the interface card senses the operating mode (RS-485, EIA-232, powered USB, or standard USB with power brick) and routes input voltages appropriately.

- When operating in RS-485 mode, the +38 V dc is converted to +24 V dc and the +5 V dc is passed straight through.
- When operating in EIA-232 or USB mode, the +24 V dc is passed through and is also converted to +5 V dc.

Note: Both voltage sources should not be connected to the printer at the same time, even if one of the sources is powered off. System damage could occur under these conditions.

RS-485 serial I/O parameters

Printer Address

35

AWAIT-60H

extra stop bits (after printer address)

BWAIT-48H

extra bits/byte (after printer data bytes)

For more information about serial I/O communications, see *4680 Store Systems Serial I/O Channel Attachment Information*, which is available from IBM Industry Corporate Relations.

Cash drawer connector pin assignments

The SureMark printers have a single cash drawer connector. This connector can drive either a single cash drawer (see “Description of models” on page 4 for the cable part number) or two cash drawers using a special cable. The connector also provides a status line which indicates if one of the cash drawers is open.

Drive voltage for each cash drawer solenoid is 24 V dc at a current of 1 ampere.

Connector pins are assigned as follows:

Table 7. Cash drawer connector pin assignments

Pin	Signal
1	Not Connected
2	Solenoid 1 Driver
3	Cash Drawer Status
4	+24 V dc
5	Solenoid 2 Driver
6	Ground

The cash drawer solenoids should be connected between pins 4 and 2 for cash drawer 1 and between pins 4 and 5 for cash drawer 2. A Y-cable is required to bring out all the appropriate lines to attach the two units.

The cash drawer status line has a 10k resistor pull-up connected to the +5 V dc.

Note: The drawer sensor should switch pin 6 to pin 3 when the drawer is open.

EIA-232 connector pin assignments

SureMark printers contain a 9-pin D-shell connector port for EIA-232 communication. This port is on the interface card, accessible under the printer without removing printer covers. The connector has the following pin functions:

Table 8. EIA-232 connector pin functions

Pin	Signal	Pin	Signal
1	Not Connected	6	DSR (Not connected on 3-wire cable)
2	Transmit	7	Not Connected
3	Receive	8	RTS
4	DTR (Not connected on 3-wire cable)	9	Not Connected
5	Signal Ground		

See “Description of models” on page 4 for the cable part number.

EIA-232 parameters

Protocol

DTR/DSR mode or XON/XOFF mode. Dip switch selectable.

Baud rate

9600 or 19 200 kbps. Dip switch selectable.

Start 1 bit

Data 8 bits

Parity None

Stop 1 bit

Table 9. 9-pin to 9-pin EIA-232 connector layout

System Description	Printer Description
Pin 2 - Rx (input)	Pin 2- Tx (Output)
Pin 3 - Tx (Output)	Pin 3 - Rx (Input)
Pin 4 - DTR (Output)	Pin 4 - DTR (Input)
Pin 5 - Gnd	Pin 5 - Gnd
Pin 6 - DSR (Input)	Pin 6 - DSR (Output)
Pin 8 - CTS (Input)	Pin 8 - RTS (Output)

Table 10. 25-pin to 25-pin EIA-232 connector layout

System Description	Printer Description
Pin 2 - Tx (Output)	Pin 3 - Rx (Input)
Pin 3 - Rx (Input)	Pin 2 - Tx (Output)
Pin 5 - CTS (Input)	Pin 8 - RTS (Output)
Pin 6 - DSR (Input)	Pin 6 - DSR (Output)
Pin 7 - Gnd	Pin 5 - Gnd
Pin 20 - DTR (Output)	Pin 4 - DTR (Input)

USB connector pin assignments

SureMark printers contain a USB port, if the USB feature is installed. This port is on the interface card, accessible under the printer without removing printer covers. Connection to the port can be with either the standard USB Type B connector, which requires a 24 V power brick, or with the powered USB connector, which contains 24 V power lines within the communications cable.

The standard USB Type B connector has the following pin functions:

Table 11. Standard USB connector pin assignments

Pin	Signal
1	Vbus (+5 V dc)
2	Minus data
3	Plus data
4	Ground

The powered USB connector has the following pin functions:

Table 12. Powered USB connector pin assignments

Pin	Signal
1	Ground (+24 V dc)
2	+24 V dc
3	Ground (Vbus)
4	Plus data
5	Minus data
6	Vbus +5 V dc
7	+24 V dc
8	Ground (+24 V dc)

See “Description of models” on page 4 for the cable part numbers.

Code page definitions

The SureMark printer has a resident character set that supports these code pages:

- Generic
- 437 (US)
- 850 (International) – Models T11 and T12 only
- 858 (International) – Models T13, T14, T18, T19, TG3, TG4, TG8, TG9, TF6 and TM6
- 860 (Portuguese)
- 863 (Canadian French)
- 865 (Norwegian)

Note: Code page 850 contains all characters from code page 858, except the EURO character.

Four user-defined character sets for thermal printing and two character sets for impact printing can be downloaded, if desired, using the 4610 Installation Utility Diskette. See “Resources on the Internet” on page 44 for more information.

Generic code page

Hex1st 2nd	2_	3_	4_	5_	6_	7_	8_	9_	A_	B_	C_	D_	E_	F_
_0		0	@	P	.	p	Ç	É	á	.	.	H.		Õ
_1	!	1	A	Q	a	q	ü	æ	í	↑	.	l	ð	μ
_2	"	2	B	R	b	r	é	Æ	ó	↓	.		Đ	Ɔ
_3	#	3	C	S	c	s	â	ô	ú	←	.	.	Ê	Ɔ
_4	\$	4	D	T	d	t	ä	ö	ñ	→	.	.	Ë	Ú
_5	%	5	E	U	e	u	à	ò	Ñ	Á:	.	.	È	Û
_6	&	6	F	V	f	v	å	û	Ğ	Â	ã	.	í	Ù
_7	'	7	G	W	g	w	ç	ù	ğ	À	Ã	.	î	ý
_8	(8	H	X	h	x	ê	ÿ	ı	İ	ℓ	.	ï	Ý
_9)	9	I	Y	i	y	ë	Ö	°	‡	ƒ	.	ì	±
_A	*	:	J	Z	j	z	è	Ü	Pt		⊥	©	Ó	÷
_B	+	;	K	[k	{	ï	ø	¥	⌈	⌋	™	β	.
_C	,	<	L	\	l		î	£	§	⌋	⌈	sm	Ô	⌈
_D	-	=	M]	m	}	ì	Ø	i	ç	=	.	Ò	■
_E	.	>	N	^	n	~	Ä	§	®	€	‡	.		
_F	/	?	O	_	o	.	Å	§	α	★	⊙	.	õ	▶

Figure 44. Printer's resident character set - generic code page

Code page 437

Hex 1st 2nd	2_	3_	4_	5_	6_	7_	8_	9_	A_	B_	C_	D_	E_	F_
_0	.	0	@	P	.	p	Ç	É	á
_1	!	1	A	Q	a	q	ü	æ	í	.	.	.	β	±
_2	"	2	B	R	b	r	é	Æ	ó
_3	#	3	C	S	c	s	â	ô	ú
_4	\$	4	D	T	d	t	ä	ö	ñ
_5	%	5	E	U	e	u	à	ò	Ñ
_6	&	6	F	V	f	v	å	û	μ	÷
_7	'	7	G	W	g	w	ç	ù
_8	(8	H	X	h	x	ê	ÿ	ı	.	ℓ	.	.	.
_9)	9	I	Y	i	y	ë	Ö	.	†	ƒ	.	.	.
_A	*	:	J	Z	è	z	è	Ü	.		±	.	.	.
_B	+	;	K	[k	{	ï	ç	.	ƒ	ƒ	.	.	.
_C	,	<	L	\	l	l	î	£	.	ƒ	ƒ	.	.	.
_D	-	=	M]	m	}	ì	.	i	.	=	.	.	.
_E	.	>	N	^	n	~	Ä	.	.	.	†	.	.	H
_F	/	?	O	-	o	.	Å	I

Figure 45. Code Page 437

Code page 858

Hex 1st 2nd →	2_	3_	4_	5_	6_	7_	8_	9_	A_	B_	C_	D_	E_	F_
_0	.	0	@	P	.	p	Ç	É	á	.	.	ø	Ó	.
_1	!	1	A	Q	a	q	ü	æ	í	.	.	Ð	β	±
_2	"	2	B	R	b	r	é	Æ	ó	.	.	Ê	Ô	.
_3	#	3	C	S	c	s	â	ô	ú	.	.	Ë	Ò	.
_4	\$	4	D	T	d	t	ä	ö	ñ	.	.	È	õ	.
_5	%	5	E	U	e	u	à	ò	Ñ	Á	.	€	Õ	.
_6	&	6	F	V	f	v	å	û	Ğ	Â	.	í	μ	÷
_7	'	7	G	W	g	w	ç	ù	ğ	À	.	î	ρ	.
_8	(8	H	X	h	x	ê	ÿ	ı	İ	ℓ	ï	ρ	.
_9)	9	I	Y	i	y	ë	Ö	.	‡	ƒ	.	Ú	.
_A	*	:	J	Z	j	z	è	Ü	.		‡	.	Û	.
_B	+	;	K	[k	{	ï	ø	.	ƒ	ƒ	.	Ù	.
_C	,	<	L	\	l		î	£	.	ƒ	ƒ	.	ý	.
_D	-	=	M]	m	}	ì	Ø	i	ç	=	.	Ý	.
_E	.	>	N	^	n	~	Ä	Ş	.	.	‡	ì	.	H
_F	/	?	O	-	o	.	Å	ş	.	.	α	.	.	I

Figure 46. Code Page 858

Code page 860

Hex 1st 2nd	2_	3_	4_	5_	6_	7_	8_	9_	A_	B_	C_	D_	E_	F_
_0	.	0	@	P	.	p	Ç	É	á
_1	!	1	A	Q	a	q	ü	À	í	.	.	.	β	±
_2	"	2	B	R	b	r	é	È	ó
_3	#	3	C	S	c	s	â	ô	ú
_4	\$	4	D	T	d	t	ã	õ	ñ
_5	%	5	E	U	e	u	à	ò	Ñ
_6	&	6	F	V	f	v	Á	Ú	μ	÷
_7	'	7	G	W	g	w	ç	ù
_8	(8	H	X	h	x	ê	ì	¿	.	ℓ	.	.	.
_9)	9	I	Y	i	y	Ê	Õ	Ò	‡	ƒ	.	.	.
_A	*	:	J	Z	j	z	è	Ü	.		±	.	.	.
_B	+	;	K	[k	{	ì	ç	.	ƒ	π	.	.	.
_C	,	<	L	\	l	l	Ô	£	.	ƒ	‡	.	.	.
_D	-	=	M]	m	}	ì	Ù	i	.	=	.	.	.
_E	.	>	N	^	n	~	Ã	.	.	.	‡	.	.	H
_F	/	?	O	_	o	.	Â	Ó	I

Figure 47. Code Page 860

Code page 863

Hex 1st 2nd	2_	3_	4_	5_	6_	7_	8_	9_	A_	B_	C_	D_	E_	F_
_0	.	0	@	P	.	p	Ç	É
_1	!	1	A	Q	a	q	ü	È	β	±
_2	"	2	B	R	b	r	é	Ê	ó
_3	#	3	C	S	c	s	â	ô	ú
_4	\$	4	D	T	d	t	Â	Ë
_5	%	5	E	U	e	u	à	Ï
_6	&	6	F	V	f	v	.	û	μ	÷
_7	'	7	G	W	g	w	ç	ù
_8	(8	H	X	h	x	ê	α	î	.	ℓ	.	.	.
_9)	9	I	Y	i	y	ë	Ô	.	†	ƒ	.	.	.
_A	*	:	J	Z	j	z	è	Ü	.		±	.	.	.
_B	+	;	K	[k	{	ï	ç	.	ƒ	π	.	.	.
_C	,	<	L	\	l	l	î	£	.	ƒ	†	.	.	.
_D	-	=	M]	m	}	=	Ù	.	.	=	.	.	.
_E	.	>	N	^	n	~	À	Û	.	.	†	.	.	H
_F	/	?	O	_	o	I

Figure 48. Code Page 863

Code page 865

Hex 1st 2nd	2_	3_	4_	5_	6_	7_	8_	9_	A_	B_	C_	D_	E_	F_
_0	.	0	@	P	.	p	Ç	É	á
_1	!	1	A	Q	a	q	ü	æ	í	.	.	.	β	±
_2	"	2	B	R	b	r	é	Æ	ó
_3	#	3	C	S	c	s	â	ô	ú
_4	\$	4	D	T	d	t	ä	ö	ñ
_5	%	5	E	U	e	u	à	ò	Ñ
_6	&	6	F	V	f	v	å	û	μ	÷
_7	'	7	G	W	g	w	ç	ù
_8	(8	H	X	h	x	ê	ÿ	ı	.	ℓ	.	.	.
_9)	9	I	Y	i	y	ë	Ö	.	‡	ƒ	.	.	.
_A	*	:	J	Z	j	z	è	Ü	.		±	.	.	.
_B	+	;	K	[k	{	ï	ø	.	ƒ	ƒ	.	.	.
_C	,	<	L	\	l		î	£	.	ƒ	ƒ	.	.	.
_D	-	=	M]	m	}	ì	Ø	i	.	=	.	.	.
_E	.	>	N	^	n	~	Ä	.	.	.	‡	.	.	H
_F	/	?	O	-	o	.	Å	.	α	I

Figure 49. Code Page 865

Character fonts

This section describes font capabilities. For more information about font-related commands, see:

- “Download user-defined characters” on page 118
- “Set print station” on page 134
- “Set print mode” on page 129
- “Set code page” on page 135
- “Set intercharacter spacing” on page 135
- “Select user-defined or resident character sets” on page 134

Thermal printing font

There are three font sizes for the resident character set on Models T13, T14, T18, T19, TG3, TG4, TG8, TG9, TF6, and TM6 (only fonts A and B are available for Models T11 and T12):

- Font A is 10 dots (wide) × 20 dots (high) with the last 2-dot row used for descenders.
(1.25 mm × 2.5 mm character height including descenders, 1.25 mm × 2.25 mm excluding descenders)
- Font B is 12 dots (wide) × 24 dots (high) with the last 2-dot row used for descenders.
(1.5 mm × 3.0 mm character height including descenders, 1.5 mm × 2.75 mm excluding descenders)

- Font C is 8 dots (wide) × 16 dots (high) with the last 2-dot row used for descenders.
(1.0 mm × 2.0 mm character height including descenders, 1.0 mm × 1.75 mm excluding descenders)
- Font C, starting with level 38 micro code, is 8 dots (wide) and 20 dots (high) with the last 2-dot row used for descenders.
(1.0 mm × 2.5 mm character height including descenders, 1.0 mm × 2.25 mm excluding descenders)

The number of characters printed per inch depends on the character size, the intercharacter spacing, and the chosen font. For example:

- 17 cpi ⇒ 10-dot wide character + 2-dot space (font A) ⇒ 48 characters per line
- 15 cpi ⇒ 10-dot wide character + 3-dot space (font A) ⇒ 44 characters per line
- 12 cpi ⇒ 12-dot wide character + 5-dot space (font B) ⇒ 34 characters per line
- 20 cpi ⇒ 8-dot wide character + 2-dot space (font C) ⇒ 57 characters per line

You can choose the character size of four user-defined character sets (code pages) or two proportional fonts. The parameter ranges for user-defined character sets are:

- $8 \leq \text{dot width} \leq 16$
- $16 \leq \text{dot height} \leq 32$ (must be a multiple of 2)

The parameter ranges for characters in proportional fonts are:

- $8 \leq \text{dot width} \leq 32$
- $8 \leq \text{dot height} \leq 32$

Notes:

1. Any of the thermal printing fonts can be scaled up to eight times the defined width and eight times the defined height. The scaling factor for the width does not have to equal the scaling factor for the height. For example, you could specify twice the width and five times the height.
2. For paper that has a width of 80 mm, the cash receipt print line is 72 mm (2.83 in.) long. There are 576 dots per line and 203 dots per inch.

Impact printing fonts (Models TI1, TI2, TI3, TI4, TI8, TI9, TG3, TG4, TG8, and TG9)

The resident character set has a font of 7 half-dots (wide) × 9 dots (high). There are no descenders.

- Font A prints 150 half-dots per inch = resident character size is 1.2 mm × 2 mm.
- Font B prints 120 half-dots per inch = resident character size is 1.5 mm × 2 mm.

The number of characters printed per inch depends on the character size, the intercharacter spacing, and the chosen font. For example:

- 17 cpi ⇒ font A with 7 half-dot-wide character + 2 half-dot space ⇒ 52 characters per line
- 15 cpi ⇒ font A with 7 half-dot-wide character + 3 half-dot space ⇒ 47 characters per line
- 12 cpi ⇒ font B with 7 half-dot-wide character + 3 half-dot space ⇒ 37 characters per line

You can choose the character size of the two user-defined character sets (code pages) within the following parameters:

- $4 \leq \text{half-dot width} \leq 16$
- $4 \leq \text{dot height} \leq 16$

Notes:

1. Any of the impact printing fonts can be printed double-wide, double-high, or both double-wide and double-high unless the dot height is more than 9. With Models T11 and T12, you can not print the character double-high if its dot height is more than 9. For better print quality with double-high characters, set the printer to unidirectional print mode. (See “Set or cancel unidirectional printing” on page 133.)
2. User-defined characters greater than 9 dots high can not be printed in landscape mode.
3. The portrait document print line is 80.35 mm (3.16 inches) long. There are 474 half-dots per line for font A, and 379 half-dots per line for font B. The landscape print line depends on the size of the document inserted.
4. You can print in two densities on the impact printer: 120 half-dots per inch or 150 half-dots per inch. Refer to the description of bits 0 and 1 in “Set print mode” on page 129 for information about changing the density.

Appendix D. EIA-232 programming information

EIA-232 commands summary by function	104
Alphabetized EIA-232 commands summary	108
System commands	111
Exercise program	111
Verify previous commands completed	111
Status request.	112
Extended address command-request printer ID	112
Preset or Onetime-Set commands	114
All models	114
Models T18 and T19 only	114
Download graphics (logo) commands	115
Predefine messages	117
Download user-defined characters	118
Thermal code page	119
Proportional font	120
Impact code page	122
Flash storage write	123
Erase flash EPROM sector	123
Send checksum of flash EPROM sector	124
Microcode tolerance (MCT) information - loading	124
Microcode tolerance (MCT) information - request	125
Setup commands	129
Set print mode	129
Set or cancel double-wide mode	130
Set or cancel double-high mode	131
Set or cancel underline mode	131
Set or cancel overline mode	131
Set or cancel invert mode	131
Set or cancel emphasized printing	132
Select maximum print speed	132
Set or cancel unidirectional printing	133
Request document length for landscape print	133
Set document length for landscape print	133
Set print station	134
Select user-defined or resident character sets	134
Set code page	135
Set intercharacter spacing	135
Set or cancel rotated characters	135
Set print station parameters.	136
Select 1/8-inch line spacing.	136
Select 1/6-inch line spacing.	136
Select color printing.	137
Set line spacing using minimum units	137
Set sheet eject length	138
Set horizontal tab positions	138
Set left margin position	138
Set relative position.	139
Align positions.	139
Set error recovery function	140
Define document wait time	141
Status sent to system	141
Select character for reprinted lines	142
Re-initialize the printer.	142

Enable or disable the feed buttons	143
Enable or disable the beeper (Models TF6 and TM6 only)	143
Enable or disable upside-down printing	144
Select character size for scalable fonts	145
Fix font matrix.	146
Print logo inline	146
Select thermal paper	147
Bar code commands	147
Print bar code	147
Print bar code examples	152
Select horizontal size of bar code	152
Select bar code height	152
Select printing position of human readable information (HRI)	152
Select font for HRI	153
Print PDF417 bar code	153
Print PDF417 bar code using binary mode	154
Select PDF417 ECC (error correction codewords) level	154
Select aspect ratio PDF417 bar code	155
Enable PDF417 truncation	155
Print character commands	156
Print and line feed	156
Print and line feed	156
Print, form feed, and cut the paper (FF)	156
Print and feed paper n lines.	156
Print and feed paper using minimum units	156
Print and feed paper in reverse using minimum units	157
Print graphic messages	157
Select and print a graphics (logo) command.	157
Print predefined graphics (logo) command	159
Print predefined messages	159
Miscellaneous commands	160
Tab to next tab stop	160
Return home (select print head location)	160
Paper cut/DI eject	161
Generate drive pulse for cash drawer	161
Retrieve the flash storage	161
Retrieve size of user flash storage	162
Retrieve printer usage statistics	162
Check processing commands (Models TI2, TI4, TI8, TI9, TG4, TG8, and TG9 only)	164
Models TI8 and TI9 MICR read commands	164
MICR read	165
Flip check	166
Document scanner commands.	166
Start scan	166
Print scanned image	168
Store scanned image and/or select partial image for retrieval	169
Retrieve scanned image	172
Scanner calibration	173
Retrieve next image location	174
Retrieve first unread image location.	174
Select compression format and scanned image threshold.	174
Asynchronous (real-time) commands	175
Real-time requests	175
Data buffer management and batch printing	176
Reset line count	176

Disable line count 176

Hold printing until buffer is released 177

Page mode printing commands 177

 Select page mode 177

 Select standard mode 177

 Select printable area 178

 Select printing direction/position 178

 Set vertical position 178

 Set relative vertical position 179

 Set left margin position (standard mode), set absolute print position (page mode) 179

 Set relative horizontal position 180

 Set printing position 180

 Print and form feed and cut the paper 181

 Print page in page mode 181

 Clear print data in page mode 181

Document handling 181

 Portrait mode 181

 Landscape mode 182

 Landscape printing commands 183

 Status summary 184

 Message from the printer 184

 Status byte 1 184

 Status byte 2 185

 Status byte 3 185

 Status byte 4 185

 Status byte 5 186

 Status byte 6 186

 Status byte 7 186

 Status byte 8 186

This information applies only to SureMark printers that attach to a POS system with an EIA-232 cable connection.

If you use the RS-485 or USB communications interface, refer to either the SureMark driver documentation in the appropriate IBM book for your operating system (see Table 13) or, when using OPOS drivers, to the *OLE for Retail POS Application Programming Guide*.

Table 13. Driver documentation by operating system

Operating System	IBM Publication
4690 OS Version 1 and Version 2	IBM 4690 OS API Specification for IBM 4610 Printers
DOS	IBM Point-of-Sale Subsystem for DOS Programming Reference
OS/2, Windows NT, Windows 95, and Windows 3.1x	IBM Point of Sale Subsystem Programming Reference and User's Guide

The 4690 OS manual is available on the current maintenance diskette for the IBM 4690 Operating System. Current versions of all three manuals are available on the Internet. See "Resources on the Internet" on page 44 for more information.

EIA-232 commands summary by function

The commands listed in Table 14 are described in detail in following sections of this appendix.

Table 14. EIA-232 commands organized by function

Description	Command	Page
System Commands		
Exercise Program	ESC x or X'1B78'	111
Status request	ESC v or X'1B76'	112
Extended address command (request printer ID)	GS SOH or X'1D4901' This is an IMMEDIATE command.	112
Verify previous commands completed	X'1B008000'	111
Preset or Onetime-Set Commands		
Download graphics (logo) commands	GS * <i>logo# n1 n2 data</i> or X'1D2A'; <i>logo#;n1;n2;data</i>	115
Predefine messages	GS : <i>message# data</i> GS : or X'1D3A'; <i>message#;data;</i> X'1D3A'	117
Download user-defined characters	ESC & <i>s n m data</i> or X'1B26; <i>s;n;m;data</i> '	118
Thermal code page	MCT commands	119
Proportional font	ESC & <i>s n m data</i> or X'1B26; <i>s;n;m;data</i> '	120
Flash storage write	ESC ' <i>n1 n2 data</i> or X'1B27; <i>n1;n2;data</i> '	123
Erase flash EPROM sector	ESC # <i>n</i> or X'1B23; <i>n</i> '	123
Send checksum of flash EPROM sector	ESC " <i>n</i> or X'1B22; <i>n</i> '	124
Microcode tolerance (MCT) information - loading	ESC M <i>n h l</i> or X'1B4D; <i>n;h;l</i> .'	124
Microcode tolerance (MCT) information - request	ESC S <i>n</i> or X'1B53; <i>n</i> '	125
Setup Commands		
Set print mode	ESC ! <i>n</i> or X'1B21; <i>n</i> '	129
Set or cancel double-wide mode	ESC W <i>n</i> or X'1B57; <i>n</i> '	130
Set or cancel double-high mode	ESC h <i>n</i> or X'1B68; <i>n</i> '	131
Set or cancel underline mode	ESC - <i>n</i> or X'1B2D; <i>n</i> :'	131
Set or cancel overline mode	ESC x'5F' <i>n</i> or X'1B5F; <i>n</i> '	131
Set or cancel invert mode	ESC H <i>n</i> or X'1B48; <i>n</i> '	131
Set or cancel emphasized printing	ESC G <i>n</i> or X'1B47; <i>n</i> '	132
Select maximum print speed	ESC / <i>n</i> or X'1B;2F; <i>n</i> '	132
Set or cancel unidirectional printing	ESC U <i>n</i> or X'1B55; <i>n</i> '	133
Set or cancel rotated character	ESC V <i>n</i> or X'1B56; <i>n</i> '	135
Set print station	ESC c 0 <i>n</i> or X'1B6330; <i>n</i> '	134
Select user-defined or resident character sets	ESC % <i>n</i> or X'1B25; <i>n</i> '	134
Set code page	ESC t <i>n</i> or X'1B74; <i>n</i> '	135
Set intercharacter spacing	ESC SP <i>n</i> or X'1B20; <i>n</i> '	135

Table 14. EIA-232 commands organized by function (continued)

Description	Command	Page
Set print station parameters	ESC c 1 n or X'1B6331;n'	136.
Select 1/8-inch line spacing	ESC 1 or X'1B31'.	136
Select 1/6-inch line spacing	ESC 2 or X'1B32'	136
Select color printing	ESC r n or X'1B72;n'	137
Set line spacing using minimum units	ESC 3 n or X'1B33;n'	137
Set sheet eject length	ESC C n or X'1B43;n'	138
Set horizontal tab positions	ESC D [n1 n2] NUL NUL or X'1B44[n1 n2]0000'	138
Set left margin position	ESC \$ n1 n2 or X'1B24;n1;n2'	138
Set relative position	ESC \ n1 n2 or X'1B5C;n1;n2'	139
Align positions	ESC a n or X'1B61;n'.	139
Set error recovery function	ESC c 4 n or X'1B63;34;n'	140
Define document wait time	ESC f x y or X'1B66;x;y'	141
Status sent to system	ESC) n or X'1B29;n'	141
Select character for reprinted lines	ESC + n or X'1B2B;n'	142
Re-initialize the printer	ESC @ or X'1B40'.	142
Enable/disable the feed buttons	ESC c 5 n X'1B6335;n'	143.
Enable/disable the beeper	ESC BEL n1 n2 or X'1B07;n1;n2'	143
Enable/disable upside-down printing	ESC { n or X'1B7B;n'	144
Select character size for scalable fonts	GS ! n or X'1D21;n'	145
Fix font matrix	ESC : n or X'1B3A n'	146
Print logo inline	GS J d n1 n2 data or X'1D4A;d;n1;n2;data'	146
Enable/disable two-color printing	GS ; n or X'1D3B;n'	147
Request document length for landscape print	GS N X'02' Null or X'1D4E0200'	133
Set document length for landscape print	GS c 1 n where n is 2 bytes indicating the length of the document in print motor steps	133
Bar Code Commands		
Print bar code	GS k n NUL or X'1D6B;n;data;00'	147
Select horizontal size of bar code	GS w n or X'1D77;n'	152
Select bar code height	GS h n or X'1D68;n'	152
Select printing position of human-readable information (HRI)	GS H n or X'1D48;n'	152
Select font for HRI	GS f n or X'1D66;n'	153
Print PDF417 bar code	GS P data NUL or X'1D50;data;00'	153
Print PDF417 bar code using binary mode	GS U datalength data or X'1D;55;datalength;data;00'	154
Select PDF417 ECC Level	GS R n or X'1D52;n1;n2'	154
Select Aspect Ratio PDF417 bar code	GS S r;c or X'1D53;r;c'	155

Table 14. EIA-232 commands organized by function (continued)

Description	Command	Page
Enable PDF417 truncation	GS T <i>n</i> or X'1D54;n'	155
Print Character Commands		
Print and line feed	LF or X'0A'	156
Print and line feed	CR or X'0D'	156
Print, form feed, and cut the paper (FF)	FF or X'0C'	156
Print and feed paper <i>n</i> lines	ESC d <i>n</i> or X'1B64;n'	156
Print and feed paper using minimum units	ESC J <i>n</i> X'1B4A;n'	156
Print and feed paper in reverse using minimum units	ESC K <i>n</i> X'1B4B;n'	157
Print Graphic Messages		
Select and print a graphics (logo) command	ESC * <i>d w h data</i> or X'1B2A;d;w;h;data'	157
Print predefined graphics (logo) command	GS / <i>m logo#</i> or X'1D2F;m;logo#'	159
Print predefined messages	GS ^ <i>message#</i> or X'1D5E;message#'	159.
Miscellaneous Commands		
Tab to next tab stop	HT or X'09'	160
Return home (select print head location)	ESC < <i>n</i> or 1B3C;n	160
Paper cut/DI eject	ESC i or ESC m -- X'1B69' or X'1B6D'	161
Generate drive pulse for cash drawer	ESC p <i>m n1 n2</i> or X'1B70;m;n1;n2'	161.
Retrieve the flash storage	ESC 4 <i>n1 n2</i> X'1B34;n1;n2'	161
Retrieve size of user flash storage	ESC 4 x '03 FF FF FF' or X'1B3403FFFFFF'	162
Retrieve printer usage statistics	X'1B51 xx'	162
Check Processing Commands		
MICR read	ESC I or X'1B49'	165
Flip check	ESC 5 or X'1B35'	166
Document Scanner Commands		
Start scan	X'1B3E;n'	166
Print scanned image	X'1B30;n1;x;y;dx;dy;s1;s2;n2'	168
Store scanned image	X'1B41;n1;x0;y0;dx0;dy0;x1;y1;dx1;dy1;x2;y2;dx2;dy2;x3;y3;dx3;dy3;tagdata'	169
Retrieve scanned image	X'1B39;n1;n2;n3'	172
Scanner calibration	GS c 0 or X'1D 63 30'	173
Retrieve next image location	GS N SOH NULL or X'1D4E0100'	174
Retrieve first unread image location	GS N SOH SOH or X'1D4E0101'	174
Select compression format and scanned image threshold	X'1B4d;x;n1;n2'	174

Table 14. EIA-232 commands organized by function (continued)

Description	Command	Page
Asynchronous (Real-Time) Commands		
Real-time requests	DLE ENQ <i>n</i> or X'1005 <i>n</i> '	175
	n Description	
	31 Release print buffer	
	32 Cancel print buffer	
	33 Undefined	
	34 EC request; send status	
	35 Undefined	
	36 Undefined	
	37 Undefined	
	38 Undefined	
	40 Reset printer	
	41 Enable unsolicited status	
	42 Disable unsolicited status	
	43 Disable transparent XON/XOFF	
Data Buffer Management and Batch Printing		
Reset line count	ESC 6 or X'1B36'	176
Disable line count	ESC 8 <i>n</i> or X'1B38' <i>n</i>	176
Hold printing until buffer is released	ESC 7 or X'1B37'	177
Page Mode Printing Commands		
Select page mode	ESC L or X'1B4C'	177
Select standard mode	ESC S or X'1B4f'	177
Select printable area	ESC X or X'1B58; <i>x</i> ; <i>y</i> ; <i>dx</i> ; <i>dy</i> '	178
Select printing direction/position	ESC T <i>n</i> or X'1B54; <i>n</i> '	178
Set vertical position	GS \$ <i>y</i> or X'1D24; <i>y</i> '	178
Set relative vertical position	GS \ <i>y</i> or X'1D5C; <i>y</i> '	179
Set left margin position (standard mode), Set absolute print position (page mode)	ESC \$ <i>n1 n2</i> or X'1B24; <i>n1</i> ; <i>n2</i> '	179
Set relative horizontal position	ESC <5C>h <i>n1 n2</i> or X'1B5C; <i>n1</i> ; <i>n2</i> '	180
Set printing position	GS] <i>x y</i> or X'1D5D; <i>x</i> ; <i>y</i> '	180
Print and form feed and cut the paper	FF or X'0C'	181
Print page in page mode	ESC FF or X'1B0C'	181
Clear print data in page mode	CAN or X'18'	181

Alphabetized EIA-232 commands summary

Table 15. EIA-232 commands in alphabetical order

Description	Command	Page
Align positions	ESC a <i>n</i> or X'1B61; <i>n</i> '	139
Clear print data in page mode	CAN or X'18'	181
Disable line count	ESC 8 <i>n</i> or X'1B;38' <i>n</i>	176
Define document wait time	ESC f <i>x y</i> or X'1B66; <i>x;y</i> '	141
Download graphics (logo) commands	GS * <i>logo# n1 n2 data</i> or X'1D2A; <i>logo#;n1;n2;data</i> '	115
Download user-defined characters	ESC & <i>s n m data</i> or X'1B26; <i>s;n;m;data</i> '	118
Enable PDF417 truncation	GS T <i>n</i> or X'1D;54; <i>n</i> '	155
Enable/disable the beeper	ESC BEL <i>n1 n2</i> or X'1B;07; <i>n1;n2</i> '	143
Enable/disable the feed buttons	ESC c 5 <i>n</i> X'1B;63;35; <i>n</i> '	143.
Enable/disable two-color printing	GS ; <i>n</i> or X'1D 3B <i>n</i> '	147
Enable/disable upside-down printing	ESC { <i>n</i> or X'1B 7B <i>n</i> '	144
Erase flash EPROM sector	ESC # <i>n</i> or X'1B23; <i>n</i> '	123
Exercise program	ESC x or X'1B;78'	111
Extended address command-request printer ID	GS l or X'1D49;01'	112
Fix font matrix	ESC : <i>n</i> or X'1B 3A <i>n</i> '	146
Flash storage write	ESC ' <i>n1 n2 data</i> or X'1B27; <i>n1;n2;data</i> '	123
Flip check	ESC 5 or X'1B35'	166
Generate drive pulse for cash drawer	ESC p <i>m n1 n2</i> or X'1B70; <i>m;n1;n2</i> '	161
Hold printing until buffer is released	ESC 7 or X'1B37'	177
Impact code page	MCT commands.	122
MICR read	ESC l or X'1B49'	165
Microcode tolerance (MCT) information - loading	ESC M <i>n h l</i> or X'1B4D; <i>n;h;l</i> '	124
Microcode tolerance (MCT) information - request	ESC S <i>n</i> or X'1B53; <i>n</i> '	125
Paper cut/DI eject	ESC i or ESC m or X'1B69' or X'1B;6D'	161
Predefine messages	GS : <i>message# data</i> GS : or X'1D3A; <i>message#;data;1D3A</i> '	117
Print and feed paper <i>n</i> lines	ESC d <i>n</i> or X'1B64; <i>n</i> '	156
Print and feed paper in reverse using minimum units	ESC K <i>n</i> X'1B4B; <i>n</i> '	157
Print and feed paper using minimum units	ESC J <i>n</i> or X'1B4A; <i>n</i> '	
Print and form feed and cut the paper	FF or X'0C'	181
Print and line feed	LF or X'0A'	156
Print and line feed	CR or X'0D'	156
Print bar code	GS k <i>n</i> NUL or X'1D6B; <i>n;data;00</i> '	147

Table 15. EIA-232 commands in alphabetical order (continued)

Description	Command	Page
Print logo inline	GS J <i>d n1 n2 data</i> or X'1D 4A d n1 n2 data'	146
Print page in page mode	ESC FF or X'1B 0C'	181
Print PDF417 bar code	GS P <i>data</i> NUL or X'1D;50;data;00'	153
Print PDF417 bar code using binary mode	GS U <i>datalength data</i> or X'1D;55;datalength;data;00'	154
Print predefined graphics (logo) command	GS / <i>m logo#</i> or X'1D2F;m;logo#'	159
Print predefined messages	GS ^ <i>message#</i> or X'1D5E;message#'	159
Print scanned image	X'1B;30;n1;x;y;dx;dy;s1;s2;n2'	168
Proportional font	ESC & <i>s n m data</i> or X'1B;26;s;n;m;data'	120
Real-time requests	DLE ENQ <i>m</i> or X'1005n' n Description 31 Release print buffer 32 Cancel print buffer 33 Undefined 34 EC request; send status 35 Undefined 36 Undefined 37 Undefined 38 Undefined 40 Reset printer 41 Enable unsolicited status 42 Disable unsolicited status 43 Disable transparent XON/XOFF	175
Re-initialize the printer	ESC @ or X'1B40'	142
Request document length for landscape print	GS N X'02' Null or X'1D;4E;02;00'	133
Reset line count	ESC 6 or X'1B36'	176
Retrieve first unread image location	GS N SOH SOH or X'1D 4E 01 01'	174
Retrieve next image location	GS N SOH NULL or X'1D 4E 01 00'	174
Retrieve printer usage statistics	X'1B 51 xx'	162
Retrieve scanned image	X'1B;39;n1;n2;n3'	172
Retrieve size of user flash storage	ESC 4 x '03 FF FF FF' or X'1B;34;03;FF;FF;FF'	162
Retrieve the flash storage	ESC 4 <i>n1 n2</i> X'1B34;n1;n2'	161
Return home (select print head location)	ESC < <i>n</i> or X'1B3C;n'	160
Scanner calibration	GS c 0 or X'1D 63 30'	173
Select and print a graphics (logo) command	ESC * <i>d w h data</i> or X'1B2A;d;w;h;data'	157
Select aspect ratio PDF417 bar code	GS S <i>r;c</i> or X'1D;53;r;c'	155

Table 15. EIA-232 commands in alphabetical order (continued)

Description	Command	Page
Select bar code height	GS h <i>n</i> or X'1D68;n'	152
Select character for reprinted lines	ESC + <i>n</i> or X'1B2B;n'	142
Select character size for scalable fonts	GS ! <i>n</i> or X'1D;21;n'	145
Select color printing	ESC r <i>n</i> or X'1B;72;n'	137
Select compression format and scanned image threshold	X'1B;4d;x;n1;n2'	174
Select font for HRI	GS f <i>n</i> or X'1D66;n'	153
Select horizontal size of bar code	GS w <i>n</i> or X'1D77;n'	152
Select page mode	ESC L or X'1B;4C'	177
Select PDF417 ECC level	GS R <i>n</i> or X'1D;52;n1;n2'	154
Select printable area	ESC X or X'1B;58;x;y;dx;dy'	178
Select printing direction/position	ESC T <i>n</i> or X'1B;54;n'	178
Select printing position of human-readable information (HRI)	GS H <i>n</i> or X'1D48;n'	152
Select standard mode	ESC S or X'1B;4f'	177
Select user-defined or resident character sets	ESC % <i>n</i> or X'1B25;n'	134
Select 1/6-inch line spacing	ESC 2 or X'1B32'	136
Select 1/8-inch line spacing	ESC 1 or X'1B31'	136
Send checksum of flash EPROM sector	ESC " <i>n</i> or X'1B22;n'	124
Select maximum print speed	ESC / <i>n</i> or X'1B;2F;n'	132
Set code page	ESC t <i>n</i> or X'1B74;n'	135
Set document length for landscape print	GS c 1 <i>n</i> where <i>n</i> is 2 bytes indicating the length of the document in print motor steps	133
Set error recovery function	ESC c 4 <i>n</i> or X'1B63;34;n'	140
Set horizontal tab positions	ESC D [<i>n1 n2</i>] NUL NUL or X'1B44[<i>n1n2</i>]0000'	138
Set intercharacter spacing	ESC SP <i>n</i> or X'1B20;n'	135
Set left margin position	ESC \$ <i>n1 n2</i> or X'1B24;n1;n2'	138
Set left margin position (standard mode), Set absolute print position (page mode)	ESC \$ <i>n1 n2</i> or X'1B;24;n1;n2'	179
Set line spacing using minimum units	ESC 3 <i>n</i> or X'1B33;n'	137
Set or cancel double-high mode	ESC h <i>n</i> or X'1B68;n'	131
Set or cancel double-wide mode	ESC W <i>n</i> or X'1B57;n'	130
Set or cancel emphasized printing	ESC G <i>n</i> or X'1B47;n'	132
Set or cancel invert mode	ESC H <i>n</i> or X'1B48;n'	131
Set or cancel overline mode	ESC x'5F' <i>n</i> or X'1B5F;n'	131
Set or cancel rotated character	ESC V <i>n</i> or X'1B56;n'	135
Set or cancel underline mode	ESC - <i>n</i> or X'1B2D;n'	131
Set or cancel unidirectional printing	ESC U <i>n</i> or X'1B55;n'	133

Table 15. EIA-232 commands in alphabetical order (continued)

Description	Command	Page
Set print mode	ESC ! <i>n</i> or X'1B21; <i>n</i> '	129
Set print station parameters	ESC c 1 <i>n</i> or X'1B63;31; <i>n</i> '	136
Set print station	ESC c 0 <i>n</i> or X'1B63;30; <i>n</i> '	134
Set printing position	GS] <i>x y</i> or X'1D;5D; <i>x;y</i> '	180
Set relative horizontal position	ESC <5C>h <i>n1 n2</i> or X'1B;5C; <i>n1;n2</i> '	180
Set relative position	ESC \ <i>n1 n2</i> or X'1B5C; <i>n1;n2</i> '	139
Set relative vertical position	GS \ <i>y</i> or X'1D;5C; <i>y</i> '	179
Set sheet eject length	ESC C <i>n</i> or X'1B43; <i>n</i> '	138
Set vertical position	GS \$ <i>y</i> or X'1D;24; <i>y</i> '	178
Start scan	X'1B;3E; <i>n</i> '	166
Status request	ESC v or X'1B76'	112
Status sent to system	ESC) <i>n</i> or X'1B29; <i>n</i> '	141
Store scanned image	X'1B;41; <i>n1;x0;y0;dx0;dy0;x1;y1;dx1;dy1;x2;y2;dx2;dy2;x3;y3;dx3;dy3;tagdata</i> '	169
Tab to next tab stop	HT or X'09'	160
Thermal code page	MCT commands; see Table 17 on page 125.	119
Verify previous commands completed	X'1B;00;80;00'	111

System commands

Exercise program

EIA-232 Syntax:

ESC x or X'1B;78'

Purpose:

This tests printing functions of the printer. A test message is printed. (See Figure 36 on page 64.) If there is a document in the printer, the test message prints on the document. Otherwise, it prints at the customer receipt station.

Error Conditions:

Home Error (on document station only)

Cash Receipt Print Error

Verify previous commands completed

EIA-232 Syntax:

X'1B;00;80;00'

Purpose:

This command can be used to ensure that all commands preceding it have been completed. The application would just wait for the status return with status byte 5, bit 1 set.

Remarks:

The printer status is returned in status bytes 1–8. Status byte 5, bit 1 is set after this request has been executed. See “Status summary” on page 184 for more information.

Error Conditions:

None.

Status request

EIA-232 Syntax:

ESC v or X'1B;76'

Purpose:

The printer status is sent to the system. This command will be processed in the order it was received.

Remarks:

The printer status is returned in status bytes 1–8. See “Status summary” on page 184 for more information.

Error Conditions:

None.

Extended address command-request printer ID

EIA-232 Syntax:

GS | SOH or X'1D;49;01'

Purpose:

This will return 8 bytes of printer status plus 5 bytes of printer-specific information.

Status byte 5, bit 0 is set to 1 when responding to the extended address command. (See “Status summary” on page 184.)

where:**Byte 1**

- Device type = X'30' for non-TI8/TG8 or TI9/TG9 models and for Model TI8/TG8 or TI9/TG9 in TI4 mode
- Device type = X'31' TI8/TG8 or TI9/TG9 models in TI8 or TI9 mode

Byte 2

Device ID

- | | |
|-----------|--|
| 00 | Models TI1 and TI2 (impact DI/thermal CR) |
| 01 | Models TI3, TI4, TI8, TI9, TG3, and TG4 (high speed; impact DI/thermal CR) |
| 02 | Models TI3, TI4, TG3, and TG4 with the 2 MB option |
| 03 | Models TF6 and TM6 (512K; thermal CR) |
| 04 | Models TI3, TI4, TG3, and TG4 with the 8 MB option |
| 05 | Models TF6 and TM6 with the 8 MB option |
| 06 | Reserved |
| 07 | Models TF6 and TM6 with the 2 MB option |

Byte 3

First byte of features

Bit 0

- When byte 1 = X'30': Set to 1 when MICR is present
- When byte 1 = X'31': Reserved

Bit 1

- When byte 1 = X'30': Set to 1 when Check Flipper is present
- When byte 1 = X'31': Reserved

Bit 2

- When byte 1 = X'30': Set to 1 when the printer has the 2 MB option
- When byte 1 = X'31': Reserved

Bit 3 Set to 1 when the printer is in XON/XOFF mode

Bit 4 Reserved

Bit 5

- When byte 1 = X'30': Set to 1 when the 2 MB option is used for user flash memory
- When byte 1 = X'31': Reserved

Bit 6 Set to 1 when two-color printing is enabled.

Bit 7 Set to 1 when the printer is in Model 4 emulation mode.

Byte 4

Second byte of features

Bit 0 Set to 1 when printer is set for 58 mm paper

Bit 1 Set to 1 if Model T18/TG8 or T19/TG9 is in T14 mode when byte 1 is set to X'30'

Bit 2 Set to 1 if full scanning Model T19 or TG9 printer

Bit 3 Set to 1 when the USB interface is internal to the printer

Bits 4

Set to 1 when the printer is an RPQ, which disables the scanner

Bits 5–7

Reserved

Byte 5

EC level = EC level of loaded code

Error Conditions:

None.

Remarks:

This is an IMMEDIATE command.

Preset or Onetime-Set commands

All models

The SureMark printer has commands to specialize and tune each printer to improve its usability, performance, and uniqueness. This flexibility is provided through the use of flash erasable programmable read-only memory (flash EPROM) and an electrically erasable programmable read-only memory (EEPROM). Data in these memory devices will stay valid until it is redefined. This information only needs to be defined once because it will remain for the life of the printer or until it is redefined.

To verify that data was previously stored in the printer, the system can request a checksum on data stored in each sector.

Flash EPROM has 5 sectors. To rewrite information in a sector, you must first erase the sector.

- For logo commands and predefined messages, erasing the sector is necessary only to replace a logo or predefined message number, or when the length of the logo or message exceeds space available in that sector.
- For user flash memory, erasing the sector is necessary only when writing to an address that has already been written to.
- For user-defined thermal and impact characters, new characters can be added if they have the same matrix as characters already in the character set. If new character sets are added, the flash memory does not have to be erased. To replace characters, you must first erase the sector.

Sector Function

- | | |
|---|---|
| 1 | Download graphics (logo) Commands |
| 2 | Predefined Messages |
| 3 | Two user-defined impact character sets |
| 4 | User-defined thermal character set: four fixed matrix or 2 proportional |
| 5 | User Flash Memory |

The EEPROM stores microcode tolerances (MCT) values.

Models T18 and T19 only

Note: Model TG8 is equivalent to T18 and Model TG9 is equivalent to T19.

Models T18 and T19 provide five functions with which you can store and define data. They are:

- User-defined thermal characters
- User-defined impact characters
- Logos
- Predefined messages
- User storage
- Scanned image storage

This allows greater flexibility in allocating memory because you can allocate additional memory for one function that has not been used by another function.

There are twenty-two 64 KB sectors, for a total of 1.4 MB of flash memory available for allocation. The MCT value represents the number of 64 KB sectors assigned to the respective function. The amount of memory allocated to each function is specified by the value stored in its respective MCT location.

The user-defined thermal characters and user-defined impact characters are limited to one 64 KB sector each.

To change the memory allocation for any function, all memory partitions *must be erased*. If memory is not erased, an MCT write error status is returned. After the MCT values are written, the new ones take effect only after a reset. The new memory allocations begin with the lowest MCT address and increment up. Memory is allocated until all requests are satisfied or until all memory has been used.

Table 16. Memory allocation for Models T18 and T19 functions

Function	Default memory allocation	MCT location
User-defined impact characters	64 KB	X'A0'
User-defined thermal characters	64 KB	X'A1'
Logos	64 KB	X'A2'
Predefined messages	64 KB	X'A3'
User memory	128 KB	X'A4'
Scanned image storage	1 MB	X'A5'

Download graphics (logo) commands

EIA-232 Syntax:

GS * logo# n1 n2 data or X'1D;2A;logo#;n1;n2;data'

where:

logo# The logo number being stored.

- range = 1 to 40 for all models except T18 and T19
- range = 1 to 255 for Models T18 and T19

n1 One-eighth the number of dots in the horizontal direction (width = 8 × n1).

range = 1 to 72 for a thermal logo.

range = 1 to 59 for an impact logo.

n2 One-eighth the number of dots in the vertical direction (height = 8 × n2).

range = 1 to 255 for a thermal logo.

range = 1 to 5 for an impact logo.

data The data to form the graphics image. The number of data bytes for the image is $n1 \times n2 \times 8$

Purpose:

To store all-points-addressable print messages.

Remarks:

These messages can be positioned on the page using the commands for setting positions.

Decimal values are shown, but all parameter values (logo number, n1, n2) must be hex values when sent to the printer.

The dot density of these messages is specified when the message is printed. See “Print predefined graphics (logo) command” on page 159.

The total number of data bytes defined for all (up to 40) defined graphics messages must be less than 65 376 in all models except T18 and T19, in which the value is user-defineable.

If the parameters **logo#**, **n1**, or **n2** are out of range, the command is discarded and its remaining data is processed as print data.

This command should be sent only when the data buffer is empty. See the description of bit 6 in “Status byte 2” on page 185.

Images for the thermal logo commands will be defined by one-dot-high rows (horizontal slices), and the impact will be defined by eight-dot-high rows (vertical slices).

This command can be used to print signature captures at the printer.

1. Capture the signature as a bitmap.
2. Convert the bitmap to a series of graphics (logo) messages.
3. Hold the printer’s buffer.
4. Send the graphics messages to the printer.
5. Release the printer’s buffer.

Note: For a thermal graphic message that is 24 dots high, across the page (n1 = 72, n2 = 3) takes over 2000 bytes of data.

Example: n1 = 2 & n2 = 2

slice # row #	Bit #	1	2	3	4	5	6	7	8	9	10	11	12	13	14	15	16	Data	bytes
0 (MSB)	7	X	.	X	.	X	.	X	.	X	.	X	.	X	.	X	.	1	2
1	6	X	.	X	.	X	.	X	.	X	.	X	.	X	.	X	.	3	4
2	5	X	.	X	.	X	.	X	.	X	.	X	.	X	.	X	.	5	6
3	4	X	.	X	.	X	.	X	.	X	.	X	.	X	.	X	.	7	8
4	3	X	.	X	.	X	.	X	.	X	.	X	.	X	.	X	.	9	10
5	2	X	.	X	.	X	.	X	.	X	.	X	.	X	.	X	.	11	12
6	1	X	.	X	.	X	.	X	.	X	.	X	.	X	.	X	.	13	14
7 (MSB)	0	X	.	X	.	X	.	X	.	X	.	X	.	X	.	X	.	15	16
8 (MSB)	7	.	X	.	X	.	X	.	X	.	X	.	X	.	X	.	X	17	18
9	6	.	X	.	X	.	X	.	X	.	X	.	X	.	X	.	X	19	20
10	5	.	X	.	X	.	X	.	X	.	X	.	X	.	X	.	X	21	22
11	4	.	X	.	X	.	X	.	X	.	X	.	X	.	X	.	X	23	24
12	3	.	X	.	X	.	X	.	X	.	X	.	X	.	X	.	X	25	26
13	2	.	X	.	X	.	X	.	X	.	X	.	X	.	X	.	X	27	28
14	1	.	X	.	X	.	X	.	X	.	X	.	X	.	X	.	X	29	30
15 (LSB)	0	.	X	.	X	.	X	.	X	.	X	.	X	.	X	.	X	31	32

Bit # → (MSB) 7 6 5 4 3 2 1 0 7 6 5 4 3 2 1 0 (LSB)

Data Byte → 1 2 3 4 5 6 7 8 9 10 11 12 13 14 15 16

Data Byte → 17 18 19 20 21 22 23 24 25 26 27 28 29 30 31 32

For Thermal Graphics - Defined as:

X'1D2A010202AAAAAAAAAAAAAAAAAAAAAAAAAAAAA
55555555555555555555555555555555'

For Impact Graphics - Defined as:

X'1D2A020202FF00FF00FF00FF00FF00FF00FF00
00FF00FF00FF00FF00FF00FF00FF00FF'

Error Conditions:

Flash EPROM load error - Verify the sector was erased before downloading images.

Memory sector is full - The sector can store up to 64 KB of graphics data, after which the sector is full.

Predefine messages

EIA-232 Syntax:

GS : *message# data* GS : or X'1D3A;*message#;**data;*1D3A'

where:

- | | |
|-----------------|--|
| message# | The message number being stored.
range is 1 to 25 for all models except TI8 and TI9
range is 1 to 255 for Models TI8 and TI9 |
| data | All data and commands to be included in this message. No immediate commands can be included in the data. |

Purpose:

To store predefined messages. This cuts transmission time. This is where you can store the header and the trailer of receipts, for example.

Remarks:

- After a "GS : " occurs, all incoming commands are stored in the message until another "GS : " occurs.
- "Print predefined graphics (logo) command" on page 159 can be included in this command.
- The size of all predefined messages can not exceed 8000 bytes for all models except TI8 and TI9, in which the value is user-defineable.

Example:

```

Store a trailer message:
X'1D3A01'
'Thank You For Shopping' X'0D'
' At RSD STORE' X'0D'
'Store #1234567' X'0D'
X'1D3A'

```

This would store this message as predefined message 1. See "Print predefined messages" on page 159 for printing this trailer message. Commands for selecting the print station and print characteristics must be included with the stored message.

Limitations:

- “Print predefined graphics (logo) command” on page 159 can be included in this command. Select and print a graphics command can not be used. See “Print graphic messages” on page 157.
- “Print predefined messages” on page 159 can be included in this command, but can only be nested one message deep.

Example: Store a predefined message ('Jane Doe') at location 3, then issue the following commands:

1. X'1D3A06'
2. 'Welcome to Our Store' X'0D'
3. X'1D5E03' (This prints the message that has been stored at location 3. The message can not have a X'1D5Exx' in it, because that would be more than one level of nesting.)
4. 'Is Your Cashier Today' X'0D'
5. X'1D3A'

Using the stored message and the above commands, the resulting text will be:

```
Welcome to Our Store
Jane Doe Is Your Cashier Today
```

- These commands **can not** be included in the predefined message:
 - “Define document wait time” on page 141.
 - “Select character for reprinted lines” on page 142.
 - “Set sheet eject length” on page 138.
 - “Select and print a graphics (logo) command” on page 157.
- This command should be sent only when the data buffer is empty. See the description of bit 6 in “Status byte 2” on page 185.

Error Conditions:

Flash EPROM load error - Verify the sector was erased before downloading the messages.

Memory sector is full

Download user-defined characters

EIA-232 Syntax:

ESC & *s n m data* or X'1B26;s;n;m;data'

where:

- | | |
|-------------|---|
| s | The character set being defined. |
| 1 | User-defined thermal code page 1 |
| 2 | User-defined thermal code page 2 |
| 3 | User-defined thermal code page 3 |
| 4 | User-defined thermal code page 4 |
| 5 | User-defined impact code page 1 |
| 6 | User-defined impact code page 2 |
| n | The beginning ASCII address of the characters being defined. |
| m | The ending ASCII address of the characters being defined. |
| data | The slice data for the defined characters. Note the number of bytes is determined by which code page is being defined and the character matrix of that code page. |

Purpose:

To define a matrix pattern for user-definable code pages stored in flash EPROM.

Remarks:

- After characters are downloaded to the printer, they remain valid until you redefine them. This is true even if power to the printer is removed.
- Before the characters are defined, the sector of the flash EPROM which stores this data must be erased. (See “Erase flash EPROM sector” on page 123.) Also, the character matrix for the code page must have already been defined. (See Table 17 on page 125, MCT# 3, 4, and 5.)
- Flash EPROM sector 4 contains all user-defined code pages for the thermal print head. To redefine a code page, you must erase and reprogram all of them.
- Flash EPROM sector 3 contains both user-defined code pages for the impact print head. To redefine a code page, you must erase and reprogram both of them.
- Thermal height must be even.
- There is no way to redefine one character only. You must redefine a whole code page.
- If the parameter **s**, **n**, or **m** is out of range, the command is discarded and the remaining data is processed as print data.
- This command should be sent only when the data buffer is empty. See the description of bit 6 in “Status byte 2” on page 185.
- ASCII characters 0 through 31 are reserved for EIA-232 functions and can not be defined.

Thermal code page

You define the character matrix for each code page with MCT #2, MCT #3, MCT #23, and MCT #24 for thermal code pages 1, 2, 3, and 4, respectively. See Table 17 on page 125.

The number of data bytes per character loaded is $2 \times \text{the character height}$. The total number of data bytes for this command is $2 \times \text{the character height} \times (1+m-n)$.

Example: 10 wide x 20 high

slice # row #	1	2	3	4	5	6	7	8	9	10	Data	bytes
1	X	X	X	X	1	2
2	X	X	X	X	3	4
3	X	X	X	X	5	6
4	X	X	X	X	7	8
5	X	X	X	X	9	10
6	X	X	X	X	11	12
7	X	X	X	X	13	14
8	X	X	X	X	15	16
9	X	X	X	X	X	X	X	X	X	X	17	18
10	X	X	X	X	X	X	X	X	X	X	19	20
11	X	X	X	X	X	X	X	X	X	X	21	22
12	X	X	X	X	23	24
13	X	X	X	X	25	26
14	X	X	X	X	27	28
15	X	X	X	X	29	30
16	X	X	X	X	31	32
17	X	X	X	X	33	34
18	X	X	X	X	35	36
19	X	X	X	X	37	38
20	X	X	X	X	39	40

Bit # → (MSB) 7 6 5 4 3 2 1 0 7 6 (LSB)

Defined as:

X'1B26014848 C0C0C0C0C0C0C0C0C0C0C0C0C0C0C0FFC0FFC0F
C0C0C0C0C0C0C0C0C0C0C0C0C0C0C0C0C0C0'

The above statement defines character X'48' as an 'H'.

Note: The number of data bytes = 2 x dot height (20) = 40 bytes.

Proportional font

This command is supported only for Models TI3, TI4, TI8, TI9, TG3, TG4, TG8, TG9, TF6 and TM6.

EIA-232 Syntax:

ESC & *s n m data* or X'1B;26;s;n;m;data'

where:

- s** The character set being defined.
 - 1** User-defined thermal code page 1.
 - 3** User-defined thermal code page 3.
- n** The beginning ASCII address of the characters being defined.
- m** The ending ASCII address of the characters being defined.
- data** The height and width of the character, and the matrix pattern for the data. The number of data bytes is $(m-n+1) \times (2+wb \times 32)$. *wb* is defined in the MCT command.

Purpose:

To download and print proportional fonts (True Type fonts) in the thermal station. Each character in the code page has its own unique width and height. The matrix must be within the following ranges:

bytes that define the character. If, as in this case, the character is defined before all 64 bytes have been used, the rest of the bytes are filled with X'0' (see Figure 50).

Note: If *wb* were set to 03, then the total number of data bytes would be 98 ($3 \times 32 + 2$)

		row #
0000111100000000	0F00	1
0001111110000000	1F80	2
0011111111000000	3FC0	3
0111000011100000	70E0	4
0110000001100000	6060	5
1100000000110000	C030	6
1100000000110000	C030	7
1100000000110000	C030	8
1100000000110000	C030	9
1100000000110000	C030	10
1100000000110000	C030	11
1100000000110000	C030	12
1111111111100000	FFF0	13
1111111111100000	FFF0	14
1100000000110000	C030	15
1100000000110000	C030	16
1100000000110000	C030	17
1100000000110000	C030	18
1100000000110000	C030	19
1100000000110000	C030	20
1100000000110000	C030	21
1100000000110000	C030	22
0000000000000000	0000	23
0000000000000000	0000	24
0000000000000000	0000	25
0000000000000000	0000	26
0000000000000000	0000	27
0000000000000000	0000	28
0000000000000000	0000	29
0000000000000000	0000	30
0000000000000000	0000	31
0000000000000000	0000	32

Figure 50. Proportional font example

Impact code page

You define the character matrix for each code page with MCT #4 for impact code page 1 and MCT #5 for impact code page 2. See Table 17 on page 125.

If the matrix defines the characters as 9 dots high or less, a print line will be printed in one pass of the print head. When the matrix is defined as greater than 9 dots high, it takes two passes of the print head per print line.

Landscape printing is limited to characters with a height of 9 dots or less. If user-defined characters are to be used in landscape print mode, they must be less than 10 dots high.

The number of data bytes per character loaded is $2 \times \text{character width}$. The total number of data bytes for this command is $2 \times \text{character width} \times (1+m-n)$. Each slice is defined with two bytes; the most significant bit (MSB) of each slice is the bottom of the character.

When defining wire patterns, the same wire does *not* fire in consecutive, primary (P) and secondary (S) positions. (The printer does not check for errors in defining the character.) If the character is defined with dots in consecutive positions only one of the dots is fired.)

Example: 11 half-dots wide (or 5.5 full dots) × 9 high

slice # →	1		2		3		4		5		6	
Bit #	P	S	P	S	P	S	P	S	P	S	P	S
7 (MSB)	X
0 (LSB)	X	.	X
1	.	.	.	X	.	.	.	X
2	.	.	X	X	.	.	.
3	.	X	X	.	.
4	X	.	X	.	X	.	X	.	X	.	X	.
5	X	X
6	X	X
7 (MSB)	X	X
Data Byte	2		4		6		8		10		12	
Data Byte	1		3		5		7		9		11	
	13		15		17		19		21		22	

Defined as:

X'1B26034141FO00080014000200110000081100020014000800F000'

The above statement defines character X'41' as an 'A'.

Note: The number of data bytes = 2 × dot width (11) = 22 bytes.

Error Conditions:

Flash EPROM load error - Verify the sector was erased before downloading images.

Flash storage write

EIA-232 Syntax:

ESC ' n1 n2 data or X'1B;27;n1;n2:data'

where:

n1 = number of data bytes to store

n2 = 3-byte address where data bytes are to be stored

Error Conditions:

Flash EPROM load error - Verify the sector was erased before downloading images.

Remarks:

The valid address range for each SureMark depends on the model number and which memory option, if any, is installed. Use "Retrieve size of user flash storage" on page 162 to determine the valid range for your printer.

The command is rejected when the address is out of range.

The flash EPROM is guaranteed for a minimum life of 100,000 write/erase commands by the Flash manufacturer.

Erase flash EPROM sector

EIA-232 Syntax:

ESC # n or X'1B;23;n'

where:

n	
01	downloaded graphics
02	predefined messages
03	user-defined impact character set
04	user-defined thermal character sets
05	flash storage
06 - 07	Reserved
08	Scanned image storage area
09 - FF	Reserved

Purpose:

To erase the flash EPROM before downloading the data into the printer.

Remarks:

The command should only be sent to the printer when the buffer is empty (status byte 2, bit 6). No other commands should be sent until this command is complete.

Status byte 3, bit 7 (command complete bit) is set to show erasing is finished and the command is complete.

The flash EPROM is guaranteed for a minimum life of 100,000 write/erase commands by the Flash manufacturer.

Send checksum of flash EPROM sector

EIA-232 Syntax:

ESC " n or X'1B;22;n'

where:

n =	
01	downloaded graphics
02	predefined messages
03	user-defined impact character set
04	user-defined thermal character sets
05	flash storage
06	Reserved

Purpose:

To verify data integrity of the data loaded in the flash EPROM in the printer. A 2-byte checksum is returned.

Microcode tolerance (MCT) information - loading

EIA-232 Syntax:

ESC M n h l or X'1B;4D;n;h;l'

where:

n	Microcode tolerance (MCT) that is being adjusted
---	--

h The high-order byte of MCT data

l The low-order byte of MCT data

Purpose:

The microcode tolerance (MCT) information is used to make adjustments to the printer's microcode. MCT data is nonvolatile data stored in the printer EPROM that is specific to a printer. For example, an MCT parameter can be defined to adjust for mechanical tolerances which cause a print line to not be centered on a receipt. Another would be for adjusting for the number of motor steps to the first print position on a document. This data remains intact until changed by the user.

Remarks:

Table 17 lists the MCT values by the parameter (n). The table includes the default, the minimum, and the maximum values of each MCT.

If you try to set an MCT value out of its defined range, it is set to the closest limit (the minimum or maximum value) or rejected.

Error Conditions:

EPROM load error

Microcode tolerance (MCT) information - request

EIA-232 Syntax:

ESC S *n* or X'1B;53;*n*'

where:

n Microcode tolerance (MCT) information that is being requested

Purpose:

To enable reading MCT information from EEPROM.

Remarks:

- MCT data is sent over the serial line in status bytes 9 and 10. See Table 17 for the values of parameter *n*.
- MCT write command values that are out of range cause the command to be rejected. (See bit 7 of "Status byte 1" on page 184.)

Table 17. MCT command definitions

DEC	HEX	MCT	Default	Min	Max
2	2	Matrix of user-defined thermal code page 1 Byte 1: Dot row width Byte 2: Dot row height	X'0A14' (10x20)	X'0810'	X'1020' (16x32)
3	3	Matrix of user-defined thermal code page 2 Byte 1: Dot row width Byte 2: Dot row height	X'0A14' (10x20)	X'0810'	X'1020' (16x32)
4	4	Matrix of user-defined impact code page 1 Byte 1: Half-dot row width Byte 2: Dot row height	X'0707' (07x07)	X'0404'	X'1010' (16x16)

Table 17. MCT command definitions (continued)

DEC	HEX	MCT	Default	Min	Max
5	5	Matrix of user-defined impact code page 2 Byte 1: Half-dot row width Byte 2: Dot row height	X'0707' (07x07)	X'0404'	X'1010' (16x16)
6-22	6-16	Reserved - ATTENTION: Changing these values might damage the printer.			
23	17	Matrix of user-defined thermal code page 3 Byte 1: Dot row width Byte 2: Dot row height	X'0A14' (10x20)	X'0810'	X'1020' (16x32)
24	18	Matrix of user-defined thermal code page 4 Byte 1: Dot row width Byte 2: Dot row height	X'0A14' (10x20)	X'0810'	X'1020' (16x32)
25-29	19-1D	Reserved - ATTENTION: Changing these values might damage the printer.			
30	1E	Mode options Bits 0–12 Reserved for future use, should be left at 1 Bit 13: (DI portrait mode only) <ul style="list-style-type: none"> • 1 = Line feeds NOT executed until DI ready. (non-IBM mode) • 0 = Line feeds are executed without regard for the state of DI ready. (IBM mode) Bit 14: <ul style="list-style-type: none"> • 1 = Normal operations (IBM mode) • 0 = Switch order of font A and font B (non-IBM mode) Bit 15: <ul style="list-style-type: none"> • 0 = Disable CR (X'0D') in CR station. No line feeds in DI. (non-IBM mode) • 1 = Normal operations. Treat CR (X'0D') the same as line feeds (X'0A'). (IBM mode) 	X'FFFF'	N/A	N/A
31–53	1F–35	Reserved – IMPORTANT: Changing these values might change the printer function.			

Table 17. MCT command definitions (continued)

DEC	HEX	MCT	Default	Min	Max
54	36	<i>TI8 and TI9 only:</i> Reserved – IMPORTANT: Changing these values might change the printer function.			
		<i>TI3, TI4, TI6, TM6, TF6, and TI7:</i> Bits 9–15: Reserved for future use, should be left at 1 Bit 8: <ul style="list-style-type: none"> • 1 = Function disabled • 0 = DBCS page mode, underline moved up two dot rows Bits 2–7: Reserved for future use Bit 1: <ul style="list-style-type: none"> • 1 = Function disabled • 0 = CR; paper is cut when button is pressed for at least 120 motor steps Bit 0: <ul style="list-style-type: none"> • 1 = No mapping of user flash storage • 0 = Map user flash storage to logo space 	X'FFFF'	X'0000'	X'FFFF'
55–159	37–9F	Reserved – IMPORTANT: Changing these values might damage the printer.			
160	A0	User-defined impact character memory allocation	X'0001'	X'0000'	X'FFFF'
161	A1	User-defined thermal character memory allocation	X'0001'	X'0000'	X'FFFF'
162	A2	User-defined Logos	X'0001'	X'0000'	X'FFFF'
163	A3	Predefined messages memory allocation	X'0001'	X'0000'	X'FFFF'
164	A4	User flash storage memory allocation	X'0002'	X'0000'	X'FFFF'
165	A5	Scanned image storage memory allocation	X'0010'	X'0000'	X'FFFF'
166–175	A6–AF	Reserved			
176	B0	Scan ¹ storage template #1 predefined location X0			
177	B1	Scan ¹ storage template #1 predefined location Y0			
178	B2	Scan ¹ storage template #1 predefined location DX0			
179	B3	Scan ¹ storage template #1 predefined location DY0			
180	B4	Scan ¹ storage template #1 predefined location X1			

Table 17. MCT command definitions (continued)

DEC	HEX	MCT	Default	Min	Max
181	B5	Scan ¹ storage template #1 predefined location Y1			
182	B6	Scan ¹ storage template #1 predefined location DX1			
183	B7	Scan ¹ storage template #1 predefined location DY1			
184	B8	Scan ¹ storage template #1 predefined location X2			
185	B9	Scan ¹ storage template #1 predefined location Y2			
186	BA	Scan ¹ storage template #1 predefined location DX2			
187	BB	Scan ¹ storage template #1 predefined location DY2			
188	BC	Scan ¹ storage template #1 predefined location X3			
189	BD	Scan ¹ storage template #1 predefined location Y3			
190	BE	Scan ¹ storage template #1 predefined location DX3			
191	BF	Scan ¹ storage template #1 predefined location DY3			
192	C0	Scan ¹ storage template #2 predefined location X0			
193	C1	Scan ¹ storage template #2 predefined location Y0			
194	C2	Scan ¹ storage template #2 predefined location DX0			
195	C3	Scan ¹ storage template #2 predefined location DY0			
196	C4	Scan ¹ storage template #2 predefined location X1			
197	C5	Scan ¹ storage template #2 predefined location Y1			
198	C6	Scan ¹ storage template #2 predefined location DX1			
199	C7	Scan ¹ storage template #2 predefined location DY1			
200	C8	Scan ¹ storage template #2 predefined location X2			
201	C9	Scan ¹ storage template #2 predefined location Y2			
202	CA	Scan ¹ storage template #2 predefined location DX2			
203	CB	Scan ¹ storage template #2 predefined location DY2			

Table 17. MCT command definitions (continued)

DEC	HEX	MCT	Default	Min	Max
204	CC	Scan ¹ storage template #2 predefined location X3			
205	CD	Scan ¹ storage template #2 predefined location Y3			
206	CE	Scan ¹ storage template #2 predefined location DX3			
207	CF	Scan ¹ storage template #2 predefined location DY3			

Notes:

1. See “Store scanned image and/or select partial image for retrieval” on page 169

Setup commands

Setup commands change character font, intercharacter spacing, and the target print station.

Set print mode

EIA-232 Syntax:

ESC ! *n* or X'1B;21;*n*'

where:

n Specifies print characteristics, such as user-defined thermal and impact code pages.

Bit Number	Function	Bit=0	Bit=1	Thermal	Impact
(LSB) 0	Char/Page 0	See Below	See Below	yes	yes
1	Char/Page 1	See Below	See Below	yes	yes
2	Overline	Cancel	Set	yes	no
3	Emphasized	Cancel	Set	yes	yes
4	Double-high	Cancel	Set	yes	yes
5	Double-wide	Cancel	Set	yes	yes
6	Inverted Mode	Cancel	Set	yes	no
(MSB) 7	Underlined	Cancel	Set	yes	no

Table 18. Fonts for Models T13, T14, TG3, TG4, TG8, TG9, T18, T19, TF6, and TM6

Bit 0	Bit 1	User-Defined Thermal Code Page	User-Defined Impact Code Page @ Density	Resident Thermal	Resident Impact
0	0	Code Page 1	Code Page 1 @ 150 half-dots per inch	Font A	Font A
1	0	Code Page 2	Code Page 1 @ 120 half-dots per inch	Font B	Font B
0	1	Code Page 3	Code Page 2 @ 150 half-dots per inch	Font C	Font A
1	1	Code Page 4	Code Page 2 @ 120 half-dots per inch	Reserved	Font B

1.

Table 19. Fonts for Models T11 and T12

Bit 0	Bit 1	User-Defined Thermal Code Page	User-Defined Impact Code Page @ Density	Resident Thermal	Resident Impact
0	0	Code Page 1	Code Page 1 @ 150 half-dots per inch	Font A	Font A
1	0	Code Page 2	Code Page 1 @ 120 half-dots per inch	Font B	Font B
0	1	Code Page 3	Code Page 2 @ 150 half-dots per inch	Font A	Font A
1	1	Code Page 4	Code Page 2 @ 120 half-dots per inch	Font B	Font B

Default:

n = 00

Remarks:

- For thermal printing with resident character sets:
Font A = 10-dots (wide) × 20 dots (high) or 1.25 mm × 2.5 mm
Font B = 12-dots (wide) × 24 dots (high) or 1.5 mm × 3.0 mm
Font C = 8 dots (wide) × 16 dots (high) or 1.0 mm × 2.0 mm
Font C, starting with level 38 micro code = 8-dots (wide) × 20 dots (high) or 1.0 mm × 2.5 mm
- For impact printing:
Font A = dot density of 150 half-dots per inch (resident characters = 1.2 mm × 2.5 mm).
Font B = dot density of 120 half-dots per inch (resident characters = 1.5 mm × 2.5 mm).
Emphasized printing enable and disable, and font A or font B selection must be at the beginning of a print line to be recognized.
User-defined characters greater than 9 dots high can not be printed double high in landscape mode or in the portrait mode of Models T11 and T12.
Double-high and emphasized characters are not valid in landscape mode.
- Invert can not be used with overline or underline.
- See “Character fonts” on page 98, “Download user-defined characters” on page 118, “Set print station” on page 134, and “Select user-defined or resident character sets” on page 134 for related information.

Example:

Print mode set to font B, emphasized and underlined enabled (n = 89 hex).

Set or cancel double-wide mode**EIA-232 Syntax:**

ESC W n or X'1B;57;n'

where:**n=00** Cancel double-wide mode**n=01** Set double-wide mode

Default:
n = 00

Set or cancel double-high mode

EIA-232 Syntax:
ESC h n or X'1B;68;n'

where:

n=00 Cancel double-high mode
n=01 Set double-high mode

Default:
n = 00

Purpose:
For better print quality with double-high characters in the document station.

Remarks:
See "Set or cancel unidirectional printing" on page 133.

Set or cancel underline mode

EIA-232 Syntax:
ESC - n or X'1B;2D;n'

where:

n=00 Cancel underline mode
n=01 Set underline mode

Default:
n = 00

Remarks:
This is valid in the customer receipt station only.

Set or cancel overline mode

EIA-232 Syntax:
ESC x'5F' n or X'1B;5F;n'

where:

n=00 Cancel overline mode
n=01 Set overline mode

Default:
n = 00

Remarks:
This is valid in the customer receipt station only.

Set or cancel invert mode

EIA-232 Syntax:
ESC H n or X'1B;48;n'

where:

n=00 Cancel Invert Mode

n=01 Set Invert Mode

Default:

n = 00

Remarks:

This is valid in the customer receipt station only.

Set or cancel emphasized printing

EIA-232 Syntax:

ESC G n or X'1B;47;n'

where:

n=00 Cancel Emphasized Mode

n=01 Set Emphasized Mode

Default:

n = 00

Remarks:

This must be at the beginning of a print-line in the document portrait station. It is enabled for the entire line.

Select maximum print speed

EIA-232 Syntax:

ESC ? n or X'1B;2F;n'

where:

n=00 52 lines per second

n=01 35 lines per second

n=02 26 lines per second

n=03 15 lines per second

Default:

n = 00

Remarks:

- In the cash receipt station, the printing will slow down to the maximum selected speed. This will increase the quality of the printing and lower the current draw from the power supply when printing high density images, such as dark logos.
- This is the maximum speed being selected, so the dot utilization algorithms can still slow the speed further when necessary.
- If MCT 11 hex (17 dec), bit 11 has been set to a value of zero (maximum speed of 35 lps), then this command will not have an effect on the maximum print speed (the MCT value takes precedence).
- This command does not affect the document station.
- This command is not supported in TI-1/2 printers.
- This command used to be called **set/cancel high quality print mode** and only supported parameter byte values of 0 and 1. Code level 40 added parameter byte values of 2 and 3.

Set or cancel unidirectional printing

EIA-232 Syntax:

ESC U *n* or X'1B55;*n*'

where:

n=00 Cancels unidirectional printing

n=01 Sets unidirectional printing

Default:

n = 00

Remarks:

This is valid in the document station in portrait mode only, when there must be two passes of the print head to print one print line.

Example: double-high or emphasized print.

When unidirectional mode is set to double-high characters, it takes three passes of the print head.

In bidirectional mode, printing double-high characters takes only two passes of the print head.

Unidirectional printing takes longer but increases the quality of the print.

Request document length for landscape print

EIA-232 Syntax:

GS N X'02' *NULL* or X'1D;4E;02;00'

Purpose

To determine the length of the document in the Landscape Print station

Remarks

- Not supported on printer Models T11 and T12.
- Document length data is sent in status bytes 9 and 10.
- Status byte 5, bit 3, is sent to indicate that extra data (beyond status byte 8) is attached.

Set document length for landscape print

EIA-232 syntax:

GS c 1 *n* where *n* = 2 bytes indicating the length of the document in print motor steps.

Remarks

- Not supported on printer Models T11 and T12.
- Document length data is sent in status bytes 9 and 10.
- Status byte 5, bit 3, is sent to indicate that extra data (beyond status byte 8) is attached.

Note: There are 50 motor steps per inch. A 6-inch document = 300 steps. (Use 295 to allow a margin for error; $n=0x127$.) To calculate the number of dots per printed line:

- for **150 DPI** (dots per inch)
[$(\text{motor_steps} - 75 * 3.12) - 10 = \text{dots per line}$]
- or for a 6-inch document

(676 dots) / (10 = dots per character) = 67 characters per line

- **for 120 DPI**

[(motor steps - 75) * 2.5] - 10 = dots per line

- or for a 6-inch document

(540 dots) / (10 = dots per character) = 54 characters per line

or

Attention: It is recommended that you set the document length a few steps shorter than the actual document. If you set the document length too long the printer will feed the document out of the printer roller and an error will be generated.

Set print station

EIA-232 Syntax:

ESC c 0 n or X'1B;6330;n'

where:

n Specifies the print station.

Bit # ↓	Station
(LSB) 0	Reserved
1	Customer Receipt Station
2	Document Station - Portrait Mode
3	Document Station - Landscape Mode
4	Reserved
5	Reserved
6	Reserved
(MSB) 7	Reserved

Default:

n = 02

Remarks:

See "Document handling" on page 181.

Only one station can be set at a time. If you select more than one station, the command is ignored.

Select user-defined or resident character sets

EIA-232 Syntax:

ESC % n or X'1B;25;n'

where:

n=00 Select resident character sets

n=01 Select user-defined character sets

Default:

n = 00

Remarks:

See "Character fonts" on page 98 and "Download user-defined characters" on page 118.

Set code page

EIA-232 Syntax:

ESC t *n* or X'1B;74;*n*'

where:

- n=00** Code Page 437 - United States
- n=01** Code Page 858 - Multilingual
- n=02** Code Page 863 - Canadian-French
- n=03** Code Page 860 - Portugal
- n=04** Code Page 865 - Norway
- n=05** Printer's Generic Code Page

Default:

n = 01

Remarks:

Changing code pages is valid for resident character sets only. If user-defined character sets are enabled, this command will not do anything.

Set intercharacter spacing

EIA-232 Syntax:

ESC SP *n* or X'1B20;*n*'

where:

- n** The number of dot-spaces in the thermal print station or half-dot spaces in the impact print station.

Default:

n = 03

Maximum:

n = 08

Remarks:

If you select double-width printing, the space to the right of each character is doubled.

Set or cancel rotated characters

EIA-232 Syntax:

ESC V *n* or X'1B56;*n*'

where:

- n=00** Cancel Rotated Characters
- n=01** Set Rotated Character
- n=02** Code Page 863 - Canadian-French

Default:

n = 00

Remarks:

Rotation is 90 degrees clockwise. This command is supported only in the thermal print station.

Set print station parameters

EIA-232 Syntax:

ESC c 1 *n* or X'1B6331;*n*'

where:

n Specifies the print station.

Bit # ↓ Station

LSB 0 Reserved

1 Customer Receipt Station

2 Document Station - Portrait Mode

3 Document Station - Landscape Mode

4 Reserved

5 Reserved

6 Reserved

7 Reserved

Purpose:

This command is used for setting the line spacing, margins, and tabs.

Remarks:

More than one station can be selected at the same time if the settings are common to all of the selected stations.

Default:

n = 02 (customer receipt station)

Select 1/8-inch line spacing

EIA-232 Syntax:

ESC 1 or X'1B31'

Remarks:

In the thermal (receipt) station this would set line feeding to 25 steps/line.

In the impact (document - portrait) station this would be set to 6 steps/line.

Note: Spacing in the document-portrait is actually 8.5 lines per inch. Line spacing dimension is approximate. For the impact printer in portrait mode, the actual line spacing must be calculated using 51 steps per inch.

In the impact (document - landscape) station this would be set to 16 steps/line.

This command should be sent after "Set print station parameters."

Select 1/6-inch line spacing

EIA-232 Syntax:

ESC 2 or X'1B32'

Remarks:

In the thermal (receipt) station this would set line feeding to 34 steps/line.

In the impact (document - portrait) station this would be set to 8 steps/line.

Note: Spacing in the document-landscape is actually 6.375 lines per inch. Line spacing dimension is approximate. For the impact printer in portrait mode, the actual line spacing must be calculated using 51 steps per inch.

In the impact (document - landscape) station this would be set to 21 steps/line.

This command should be sent after "Set print station parameters" on page 136.

Select color printing

This command is not supported for Models T11 and T12.

EIA-232 Syntax:

ESC r *n* or X'1B;72;*n*;

where:

n =

- | | |
|-----------|--------------------------------------|
| 00 | Cancel color printing |
| 01 | Enable full-character color printing |
| 02 | Enable half-character color printing |

Default:

n = 00

Purpose:

To enable half-character or full-character color printing, or to disable color printing.

Remarks:

- You can enable and disable full-character color printing within a print line. This enables you to print one word in a different color.
- This command can be used up to 8 times in a line when full-character color printing is used.
- Half-character color printing is only supported at the beginning of a print line.
- If both bit 1 and bit 0 of *n* are set (*n*=03), only half-character color printing will be enabled.

Limitations:

- This command is only valid if the Enable Color Printing command (see "Select thermal paper" on page 147) is sent first.
- When color paper is enabled, depending on the paper, the printer might be limited to printing at 15 lps when printing 8 lpi.

Set line spacing using minimum units

EIA-232 Syntax:

ESC 3 *n* or X'1B33;*n*;

where:

n Specifies line feed steps.

In the customer receipt station, 1 inch = 204 steps and 1 mm = 8 steps. Thermal must be an even number.

In the document portrait station, 1 inch = 51 steps and 1 mm = 2 steps.

In the document landscape station, 1 inch = 127 steps and 1 mm = 5 steps.

This command should be sent after “Set print station parameters” on page 136.

Set sheet eject length

EIA-232 Syntax:

ESC C *n* or X'1B43;*n*'

where:

n Specifies the number of line feed steps using minimum units moved when a *FF* is sent in the receipt station.

In the document station, an eject will feed until the document has exited the lower document sensors - this length is not used.

Default:

n = A0 (160 decimal)

Maximum:

255 steps (FF hex)

This value is stored in the EEPROM in the printer so that it is not lost when the printer is reset.

Set horizontal tab positions

EIA-232 Syntax:

ESC D [*n1 n2*] NUL NUL or X'1B44[*n1n2*]0000'

where:

n1 The high-order-byte dot offset for the horizontal tab.

n2 The low-order-byte dot offset for the horizontal tab.

Default:

There is a tab every 100 dots.

Remarks:

This command should be sent after “Set print station parameters” on page 136.

Up to 5 tab positions can be stored. All 5 *n1 n2* value pairs can be included in one command. Values must be entered in hex.

A tab is calculated from the left margin position.

Tab values must be in ascending order.

Example: To set 3 tab positions - at the 100, 150 and 300 dot positions:

- X'1B4400640096012C0000'

See “Tab to next tab stop” on page 160.

Set left margin position

EIA-232 Syntax:

ESC \$ *n1 n2* or X'1B24;*n1;n2*'

where:

- n1** The high-order byte of the dot offset from the beginning of the print line.
- n2** The low-order byte of the dot offset from the beginning of the print line.

Default:

$n1 = 0, n2 = 0$

Remarks:

In the customer receipt station, 1 mm = 8 dots.

In the document station, 1 inch = 150 half-dots (75 dots).

n1 and *n2* are hex values. Convert each to decimal. Then, use this formula to get the decimal equivalent: $(n1 \times 256) + n2$.

If the number exceeds the printable area, it is ignored.

The maximum value for the customer receipt station is 576. The maximum value for the document insert station is 474.

In the customer receipt station, this number is rounded back to a factor of 8.

This command should be sent after "Set print station parameters" on page 136.

Set relative position

EIA-232 Syntax:

ESC <5C>h *n1 n2* or X'1B5C;*n1;n2*'

where:

- n1** The high-order byte of the dot offset from the left margin.
- n2** The low-order byte of the dot offset from the left margin.

Default:

$n1 = 0, n2 = 0$

Remarks:

In the thermal station, 1 mm = 8 dots.

In the impact station, 1 in. = 75-dots (150 half-dots).

n1 and *n2* are hex values. Convert each to decimal, then use this formula to get the decimal equivalent: $(n2 \times 256) + n1$

To move the position to the left, use a negative number.

Example: *To move N dots to the left* ⇒ $65536 - N$.

If this number plus the left margin exceeds the printable area it is ignored.

See "Set left margin position" on page 138.

In the customer receipt station, this number is rounded back to a factor of 8.

Align positions

EIA-232 Syntax:

ESC a *n* or X'1B61;*n*'

where:

- n = 00** Align Left
- n = 01** Align Center
- n = 02** Align Right
- n = 04** Align Column Right

Default:

n = 00

Remarks:

- Values 00, 01, and 02 are only valid at the beginning of a line.
- Tabs are only valid when printing is aligned to the left. If tabs are used when left alignment is not used, results can be unpredictable. (See “Tab to next tab stop” on page 160.)
- Alignment is relative to the left margin.
- To use the Align Column Right command:
 1. Send the characters that you want to be left aligned.
 2. Send the Align Column Right command.
 3. Send the characters that you want to be right aligned.
 4. Send an end of line command, for example X'0A' or X'0D'.

The printer will return to left aligned after the line is printed.

Limitations for n=04:

- The command is only valid in the cash receipt station.
- This command is not supported for Models T11 and T12.
- The command is ignored if the printer is not left aligned when the command is received.
- If the Align Column Right command is received but the line is filled before an EOL is received, the filled line is treated as an EOL. There are usually a few dot positions available, but not enough for a full character. The column alignment will occur on the few dot positions available.

Set error recovery function

EIA-232 Syntax:

ESC c 4 n or X'1B63;34;n'

where:

n Selects the function.

Bit # ↓	Function	Bit=0	Bit=1
LSB 0	Reserved	N/A	N/A
1	Reserved	N/A	N/A
2	Release Print Buffer after Error Correction	Release	Hold
32	Automatic retry on a Home Error	Enabled	Not Enabled
4	Hold buffer when waiting for a document	Release	Hold
5	Hold buffer after a flip error	Release	Hold

Default:

n = 00

Remarks:

When set to *not* automatically release the print buffer after error correction (bit #2), the printer does not execute commands until it receives a "Real-time requests" on page 175 command to cancel or release the print buffer.

When automatic retry on a home error is selected, the printer will try to reset the print head to a known location, then reprint the line on which the error occurred. If the printer is unable to reset the print head, operator intervention is needed.

An error will be sent back to the system and the LED will blink.

Define document wait time

EIA-232 Syntax:

ESC f x y or X'1B66;x;y'

where:

x Time the printer should wait, from receiving a print line for the document station until the document is inserted.

If the document has not been detected by the time the wait time ends, a document error is sent to the system. The system continues to wait for a document to be inserted.

Wait Time = x * 0.5 seconds

y Delay from the time the document is detected until it is *grabbed* by the printer (start of document printing):

- Side insertion - closes the document throat.
- Front insertion - pulls the document into the printer and feeds it to its top of form.

Delay = y × 0.1 seconds

Defaults:

x = 02 y = 03

Remarks:

If y = 0, the printer does not grab the document. The operator must use the document feed button to pull the document into the printer.

If x = 0, the printer *never* sends error status if no print data is sent to the document station.

This value is stored in the EEPROM in the printer so that it is not lost when the printer is reset.

Status sent to system

EIA-232 Syntax:

ESC) n or X'1B29;n'

where:

n Selects the function.

Bit # ↓	Function	Bit=0	Bit=1
LSB 0	Print Buffer Empty/Full	Yes	No
1	Reserved	Yes	No
2	Front Document Sensor Change	Yes	No

3	Top Document Sensor Change	Yes	No
4	After status byte 6 is incremented or status byte 3, bit 7, is set	Yes	No
5	Cash Draw Sensor Change	Yes	No
6	Key In Use	Yes	No
7	Cover Open	Yes	No

Remarks:

Bit 4 can be used in place of the Command Complete. When the buffer is empty, the system can assume that everything stored in the printer has been completed. To enable these status messages, unsolicited status must be enabled. See "Asynchronous (real-time) commands" on page 175.

Select character for reprinted lines

EIA-232 Syntax:

ESC + *n* or X'1B2B;*n*'

where:

n The ASCII representation of the character printed in the first character position on the print line when recovering from a home error. This occurs in impact print stations only.

Default:

n = 2A hex (This is an asterisk (*) in most code pages.)

Remarks:

The value is stored in EEPROM to prevent loss when the printer is reset. The default value after the reset is the value last sent.

Re-initialize the printer

EIA-232 Syntax:

ESC @ or X'1B40'

Purpose:

Re-initialize all printer setting to their default values and reset the impact print head.

Remarks:

Commands in the print buffer are **not** lost when this command is issued. The settings that are re-initialized follow (all numbers are in hex):

Setting	Default Value
Print Mode	00
Print Station Selected	02
User-Defined/Resident Character Sets	00
Code Page	01
Intercharacter Spacing (Single Byte)	03
Rotated Characters	00
Station for line spacing	02
Line Spacing all stations	Six LPI
Tab Positions	every 100 dots
Left Margin	00
Relative Position	00
Align Positions	00
Unidirectional printing	00
Horizontal Size of Bar Code	03
Vertical Size of Bar Code	A2
Position of HR	00
Font for HRI	00

Error Conditions:

None

Enable or disable the feed buttons

EIA-232 Syntax:

ESC c 5 *n* or X'1B;63;35;*n*'

where:

n=0 Enables feed buttons

n=1 Disables feed buttons

Default:

n = 0

Purpose:

To disable the feed buttons while in the middle of a transaction.

Remarks:

If the printer is set to have the buttons disabled, the offline tests will also be disabled. Supported on all models except T11 and T12.

Enable or disable the beeper (Models TF6 and TM6 only)

This command is supported only for Models TF6 and TM6.

EIA-232 Syntax:

ESC BEL *n1 n2* or X'1B 07 *n1 n2*'

where:

n1 Enables or disables beeper.

X'00' Disable beeper.

X'01'–X'FE'

Timed enable beeper.

X'FF' Enable beeper.

n2 Sets the beeper volume and tone.

Bits 0–3

The note. Bit 0 is the LSB.

Bits 4–5

The octave.

Bit 6 Reserved.

Bit 7 Volume. 0 = loud, 1 = soft.

Value (Bits 0–3)	Note	Value (Bits 0–3)	Note	Value (Bits 4–5)	Octave
0000–0	C	1000–8	G#	00–0	1
0001–1	C#	1001–9	A	01–1	2
0010–2	D	1010–A	A#	10–2	3
0011–3	D#	1011–B	B	11–3	4
0100–4	E	1100–C	Rest / Silence		
0101–5	F	1101–D	Reserved		
0110–6	F#	1110–E	Reserved		
0111–7	G	1111–F	1 KHz (normal beep)		

Default:

n = X'00'

Purpose:

To enable or disable the beeper.

Remarks:

- Any value other than X'00' or X'FF' is treated as an amount of time that the beeper is to be enabled. The time is calculated as $n1 \times 0.1$ seconds.
- To stop a beep command early, send the Disable Beeper command.
- Timed beeps can be chained together. They can also be downloaded as canned messages.
- A value of $n2 = X'2F'$ is recommended for the most audible tone.
- Set bits 0–3 to 1100 to put a timed silence in a beep sequence.

Enable or disable upside-down printing

This command is not supported for Models T11 and T12. This command is only supported in the thermal station.

EIA-232 Syntax:

ESC { n or X'1B 7B n'

where:

n enables or disables upside-down printing.

X'00' Disable upside-down printing.

X'01' Enable upside-down printing.

Default:

n = X'00'

Purpose:

When the printer is wall-mounted, the front of the printer points up.

Therefore, the print data appears upside down when data is printed normally. This command allows the data to be right-side up as it comes out of the printer.

Remarks:

- When upside-down printing is enabled, the last line of data must be sent to the print first.
- This command is valid only at the beginning of a print line.

Select character size for scalable fonts

This command is not supported for Models T11 and T12. This command is only supported in the thermal station.

EIA-232 Syntax:

GS ! *n* or X'1D;21;*n*'

where:

n Defines the height and width of a character. The four least significant bits (LSBs) specify the height and the four most significant bits (MSBs) specify the width of the character. See Table 20.

For example, if *n*=X'14' the scaled character will be twice the defined width and five times the defined height.

Table 20. Width and height for scalable fonts

Four MSBs (in hex)	Character Width	Four LSBs (in hex)	Character Height
0	As defined	0	As defined
1	2 × defined width	1	2 × defined height
2	3 × defined width	2	3 × defined height
3	4 × defined width	3	4 × defined height
4	5 × defined width	4	5 × defined height
5	6 × defined width	5	6 × defined height
6	7 × defined width	6	7 × defined height
7	8 × defined width	7	8 × defined height

Default:

n = 00

Purpose:

To select the size of a character.

Remarks:

- This command is valid only in the thermal print station.
- Bits 3 and 8 of *n* are ignored.
- The *Set Print Mode* command (see “Set print mode” on page 129) can also select the character height (double high and double wide). The last command that is received is the effective command.
- Underline and overline is not supported when the height is scaled 8x except on the T18, T19, TG8, and TG9.
- The bar for overline and underline is not magnified in thickness except on the T18, T19, TG8, and TG9.

Fix font matrix

This command is not supported for Models TI1 and TI2.

EIA-232 Syntax:

ESC : *n* or X'1B 3A *n*'

where:

n The character width to which all proportional characters will be adjusted. The range of valid values is $8 \leq n \leq 32$. Use X'00' to disable this command and print proportional characters normally.

Default:

n = 00

Purpose:

To fix the matrix of proportional fonts. This command will be used mostly to align numbers and decimal points.

Remarks:

- This command is valid only on proportional user-defined fonts.
- If the character is larger than the width defined by this command, then the right side of the character will be truncated.
- If the character is smaller than the width defined by this command, then the character will be centered in the space.

Print logo inline

This command is not supported for Models TI1 and TI2.

EIA-232 Syntax:

GS J *d n1 n2 data* or X'1D 4A *d n1 n2 data*'

where:

d Relative height of the character.

0 Single high

1 Double high

n1 MSB of the logo width.

n2 LSB of the logo width.

data The data to form the graphics image.

Purpose:

To print a small logo inline with characters.

Remarks:

- Thermal station only
- Rotate characters must be disabled
- *n1* and *n2* indicate the number of dots of the bit image in the horizontal direction. The number of dots is calculated as $n1 \times 256 + n2$ (after first converting *n1* and *n2* to decimal).
- The logo is 24 dot rows high. If printed in double-high mode, the logo will be 48 rows high.
- The number of data bytes to form the image is figured by $\{((n1 \times 256 + n2) - 1) / 8 + 1\} \times 24$.

- Like user-defined characters, if the image is only 14 dots wide, the last two dots should be zero to complete the byte. When printed, the image will be only 14 dots wide.

Select thermal paper

This command is not supported for Models T11 and T12.

EIA-232 Syntax:

GS ; *n* or X'1D 3B *n*'

where:

n = X'00'

Disable two-color printing.

n = X'01'

Enable color printing using print parameter set 1.

n = X'02'

Enable color printing using print parameter set 2.

n = X'03'

Enable color printing using print parameter set 3.

X'n = 04'–X'FF'

Select the print parameters to be defined.

Purpose:

To enable two-color printing and select the print parameters that are best suited for the paper selected.

Remarks:

- New parameters will be defined as new color papers become available.
- The speed of printing will change depending on the print parameters. When print parameter set 1 is used, the print speed will be 15 lines per second.
- This command setting is saved in nonvolatile memory.

Bar code commands

Bar code commands are valid in the thermal print station only.

Print bar code

EIA-232 Syntax:

GS *k n* NUL or X'1D6B;*n*;*data*'

where: **n =**

Bar Code

X'00' UPC-A

X'01' UPC-E

X'02' JAN13 (EAN-13)

X'03' JAN8 (EAN-8)

X'04' CODE 39

X'05' ITF

X'06' CODABAR

X'07' CODE 128C

X'08' CODE 93

X'09' CODE 128A, 128B, and 128C (This command is not supported for Models T11 and T12.)

data For $n=00$ through $n=08$, the ASCII representation of the characters to be printed.

For $n=09$, the hexadecimal representation of the characters to be printed. The first byte of data must be the byte-count of the remaining data. The trailing X'00' should not be included for this command.

Remarks:

- Valid at the beginning of a line only.
- This command will increment status byte 6.
- Printing will not start until X'00' is received, or the end of a data packet in RS-485.
- Data after any invalid character for a particular bar code will be discarded. The printer will continue to wait for X'00'.
- If X'00' or an invalid character is received before the required number of data bytes, zeros will be inserted following the data until the required number is reached (for UPC-A, UPC-E, JAN13, and JAN8).
- Excess characters will be discarded.
- A check digit will be generated if one is not supplied for UPC-A, JAN13, and JAN8.
- Check digits will be figured and added for Code 128C and Code 93.
- Models T11 and T12 support only Code 128C ($n=07$). They do not support codes 128A and 128B ($n=09$).
- For UPC-E, the printer will expand the data, generate a check digit and parse the data before generating the bar code (6 or 7 digits are executed). If 7 digits are received and digit 1 is 0, the last 6 digits are used.
If digit 1 is not 0, digit 1 is used and the digit 7 is ignored.
- For CODABAR, a stop and start character is required.
- A leading zero will be added to the data for ITF bar codes if the data received has an odd number of bytes.
- If a bar code width is greater than the paper width, the right of the bar code is truncated, making the bar code unreadable.
- Bar codes will always be printed in black, regardless of color printing settings.

Table 21. Code 128 character set

Value		Code		
Decimal	Hex	Set A	Set B	Set C
0	0	SP	SP	00
1	1	!	!	01
2	2	"	"	02
3	3	#	#	03
4	4	\$	\$	04
5	5	%	%	05
6	6	&	&	06
7	7	'	'	07
8	8	((08
9	9))	09
10	A	*	*	10
11	B	+	+	11
12	C	'	'	12
13	D	-	-	13
14	E	.	.	14
15	F	/	/	15
16	10	0	0	16
17	11	1	1	17
18	12	2	2	18
19	13	3	3	19
20	14	4	4	20
21	15	5	5	21
22	16	6	6	22
23	17	7	7	23
24	18	8	8	24
25	19	9	9	25
26	1A	:	:	26
27	1B	;	;	27
28	1C	<	<	28
29	1D	=	=	29
30	1E	>	>	30
31	1F	?	?	31
32	20	@	@	32
33	21	A	A	33
34	22	B	B	34
35	23	C	C	35
36	24	D	D	36
37	25	E	E	37
38	26	F	F	38

Table 21. Code 128 character set (continued)

Value		Code		
Decimal	Hex	Set A	Set B	Set C
39	27	G	G	39
40	28	H	H	40
41	29	I	I	41
42	2A	J	J	42
43	2B	K	K	43
44	2C	L	L	44
45	2D	M	M	45
46	2E	N	N	46
47	2F	O	O	47
48	30	P	P	48
49	31	Q	Q	49
50	32	R	R	50
51	33	S	S	51
52	34	T	T	52
53	35	U	U	53
54	36	V	V	54
55	37	W	W	55
56	38	X	X	56
57	39	Y	Y	57
58	3A	Z	Z	58
59	3B	[[59
60	3C	\	\	60
61	3D]]	61
62	3E	^	^	62
63	3F	_	_	63
64	40	MUL	'	64
65	41	SOH	a	65
66	42	STX	b	66
67	43	ETX	c	67
68	44	EOT	d	68
69	45	ENO	e	69
70	46	ACK	f	70
71	47	BEL	g	71
72	48	BS	h	72
73	49	HT	i	73
74	4A	LF	j	74
75	4B	VT	k	75
76	4C	FF	l	76
77	4D	CR	m	77

Table 21. Code 128 character set (continued)

Value		Code		
Decimal	Hex	Set A	Set B	Set C
78	4E	SO	n	78
79	4F	SI	o	79
80	50	DLE	p	80
81	51	DC1	q	81
82	52	DC2	r	82
83	53	DC3	s	83
84	54	DC4	t	84
85	55	NAK	u	85
86	56	SYN	v	86
87	57	ETB	w	87
88	58	CAN	x	88
89	59	EM	y	89
90	5A	SUB	z	90
91	5B	ESC	{	91
92	5C	FS		92
93	5D	GS	}	93
94	5E	RS	~	94
95	5F	US	DEL	95
96	60	FNC3	FNC3	96
97	61	FNC2	FNC2	97
98	62	SHIFT	SHIFT	98
99	63	CODE C	CODE C	99
100	64	CODE B	FNC4	CODE B
101	65	FNC4	CODE A	CODE A
102	66	FNC1	FNC1	FNC1
103	67	START CODE A		
104	68	START CODE B		
105	69	START CODE C		

Print bar code examples

Table 22. Print bar code examples

	Command	n =	Data
UPC-A	X'1D 68'	X'00'	X'30 33 31 33 32 33 31 32 30 37 38'
UPC-E	X'1D 68'	X'01'	X'34 39 30 36 39 30 00'
JAN 13 (EAN-130)	X'1D 68'	X'02'	X'34 39 31 32 33 34 35 36 37 38 39 30 00'
JAN8 (EAN-8)	X'1D 68'	X'03'	34 39 31 32 33 34 35 36 00
CODE 39	X'1D 68'	X'04'	30 31 32 33 34 35 36 37 00
ITF	X'1D 68'	X'05'	31 32 33 34 35 36 37 38 39 30 31 32 00
CODABAR	X'1D 68'	X'06'	42 39 30 2E 2B 3A 2F 24 2D 43 00
CODE 128C	X'1D 68'	X'07'	35 34 35 35 35 36 35 37 35 38 35 39 00
CODE 93	X'1D 68'	X'08'	31 32 33 34 35 36 00
Reserved	X'1D 68'	X'0A - FF'	

Select horizontal size of bar code

EIA-232 Syntax:

GS w *n* or X'1D77;n'

where:

n The horizontal magnification of the line width in the bar code, ($2 \leq n \leq 4$).

Default:

$n = 03$

Note: The last valid value is kept when an invalid value is sent.

Select bar code height

EIA-232 Syntax:

GS h *n* or X'1D68;n'

where:

n The dot height of the bar code, ($1 \leq n \leq 255$).

Default:

$n = X'A2'$ (162 decimal)

Select printing position of human readable information (HRI)

EIA-232 Syntax:

GS H *n* or X'1D48;n'

where:

n = the print position

n = X'00'
Not Printed

n = X'01'
Above the bar code

n = X'02'
Below the bar code

n = X'03'
Both above and below the bar code.

Default:
n = X'00'

Remarks:
Human readable information is normal text associated with the bar code.

Note: The last valid value is kept when an invalid value is sent.

Select font for HRI

EIA-232 Syntax:
GS f *n* or X'1D66;*n*'

where: n = the font for the HRI

n = X'00'
Font A

n = X'01'
Font B

Default:
n = X'00'

Remarks:
Only resident character sets are used:

- Font A = 10-dots (W) × 20 dots (H) or 1.25 mm × 2.5 mm
- Font B = 12-dots (W) × 24 dots (H) or 1.5 mm × 3.0 mm

Note: The last valid value is kept when an invalid value is sent.

Print PDF417 bar code

EIA-232 Syntax:
GS P *data* NUL or X'1D;50;*data*;00'

where:

data The ASCII representation of the characters to be printed.

Remarks:
Valid only at the beginning of a line. Printing will not start until a X'00' is received.

This command will increment status byte 6.

The maximum number of characters to be encoded is 1000.

Error Conditions:

If an image can not be printed, status byte 7, bit 2 will be set. This may happen when the image is too big to print. Try decreasing the ECC level.

Print PDF417 bar code using binary mode**EIA-232 Syntax:**

GS U *datalength data* or X'1D;55;datalength;data;00'

where:**datalength**

The number of data bytes to follow the bytecount. This is a two-byte variable to accommodate the 1000 maximum data bytes, i.e. X'0200' = 512 decimal data bytes.

data

The ASCII representation of the characters to be printed. Characters can have a value of X'00' to X'FF' inclusive.

Remarks:

This command encodes data into PDF417 bar codes using binary mode. Valid only at the beginning of a line. Printing will not start until all data is received.

This command will increment status byte 6.

The maximum number of characters to be encoded is 1000.

Error Conditions:

If the encoder detects an error, status byte 7, bit 2 will be set. This may happen when the amount of data is too large to be encoded. In this case, try decreasing the ECC level or decreasing the amount of data to be encoded. An unsolicited status message will be sent. (A status will be sent even if the system is ready to receive it or not.)

Select PDF417 ECC (error correction codewords) level**EIA-232 Syntax:**

GS R *n* or X'1D;52;n1;n2'

where:

n1 The high-order byte of the ECC level.

n2 The low-order byte of the ECC level.

Default:

n1 = 00

n2 = 15

Range:

$0 \leq n1n2 \leq 400$ decimal (170 hex)

Remarks:

For $0 \leq n1n2 \leq 8$, the ECC level is assumed as that particular security level. The security level determines the number of error correction codewords added to the symbol.

Error Correction

Security Level	Codewords
0	0

1	2
2	6
3	14
4	30
5	62
6	126
7	254
8	510

For $9 \leq n_1 n_2 \leq 400$, the ECC level is assumed as a percentage of the codewords in the bar code.

Select aspect ratio PDF417 bar code

EIA-232 Syntax:

GS S *r;c* or X'1D;53;*r;c*'

where:

r The height dimension for the ratio; $1 \leq r \leq 9$.

c The width dimension for the ratio; $1 \leq c \leq 9$.

Default:

$r = 1, c = 2$

Remarks:

This is not an exact ratio. The image will get as close as possible to the ratio. However, the maximum width of an image is 12 columns and the maximum height is 90 rows.

Enable PDF417 truncation

EIA-232 Syntax:

GS T *n* or X'1D;54;*n*'

where:

n **Whether to enable truncation**

0 Disable truncation.

1 Enable truncation.

Default:

$n = 0$

Remarks:

Truncated PDF generates a symbol with the right row indicator and stop pattern replaced by a single width bar. There is a slight degradation in decode performance if truncation is enabled, which allows more data to fit in the image width.

Print character commands

These commands should be sent after ASCII data is sent to the printer and is being held in the print buffer. Any of these commands will increment the line count by 1. (See “Status byte 6” on page 186 and “Reset line count” on page 176.)

Print and line feed

EIA-232 Syntax:
LF or X'0A'

Purpose:
Prints data in the print buffer and feeds the paper by a preset amount.

Print and line feed

EIA-232 Syntax:
CR or X'0D'

Purpose:
Prints data in the print buffer and feeds the paper by a preset amount.

Remarks:
There is an MCT to enable or disable this command. The default is to disable or ignore the CR command.

Print, form feed, and cut the paper (FF)

EIA-232 Syntax:
FF or X'0C'

Purpose:
Prints data in the print buffer and feeds the paper in the customer receipt station or document insert station by a preset amount, until the document exits the feed rollers. If a cutter is available at the station (CR station only), it cuts the paper.

Print and feed paper n lines

EIA-232 Syntax:
ESC d *n* or X'1B64;*n*'

where:
n Specifies the number of line feeds.

Purpose:
Prints data in the print buffer and feeds the paper by the amount specified in this command.

Print and feed paper using minimum units

EIA-232 Syntax:
ESC J *n* or X'1B4A;*n*'

where:
n Specifies the line feed steps.
In the receipt station: 1 in. = 204 steps (1 mm = 8 steps).
In the document portrait station: 1 in. = 51 steps (1 mm = 2 steps).

In the document landscape station: 1 in. = 127 steps (1 mm = 5 steps).

Note: Line spacing dimension is approximate. For the impact printer in portrait mode, the actual line spacing must be calculated using 51 steps per inch.

Purpose:

Prints data in the print buffer and feeds the paper by the amount specified in this command.

Print and feed paper in reverse using minimum units

EIA-232 syntax:

ESC K *n* X'1B;4B;*n*' where *n* specifies the number of line feed steps. One inch = 51 steps (1 mm = 2 steps)

Purpose:

This command may be used to print on a particular line on a document. The data in the print buffer is printed and the paper is fed by the amount specified in this command. When the document is inserted until the line can just be seen at the printer cover, and this command is sent with *n*=0x65, the next line printed lines up with the line seen at the top cover. This replaces the Open Throat command for full check scan (TI9/TG9) printers.

Limitations:

- This command is valid only for the document station.
- This command is valid only for Models Tx8 and Tx9.

Print graphic messages

Select and print a graphics (logo) command

EIA-232 Syntax:

ESC * *d w h data* or X'1B2A;*d;w;h;data*'

where:

d Dot density.

00 Normal Print - 200 dpi in the receipt station, 150 dpi in the document station.

Note: In the document station, this takes three passes of the print head for a logo that is 8 dots high.

01 Double wide - 100 dpi in the receipt station, 75 dpi in the document station.

Note: In the document station, this takes one pass of the print head for a logo that is 8 dots high.

02 Double wide and high - 100 dpi in the receipt station, 75 dpi in the document station. Every dot row in the vertical direction will be printed twice.

w One-eighth the number of dots in the horizontal direction, (width = 8 × *w*)

range = 1 to 72 for a thermal logo.

range = 1 to 59 for an impact logo.

In the receipt station, 1 = 8 dots = 1 mm.

In the document station, 6 = 48 dots = 1 inch.

h One-eighth the number of dots in the vertical direction, (height = $8 \times h$).

range = 1 to 255 for a thermal logo.

range = 1 to 5 for an impact logo.

data The data to form the graphics image.

The number of data bytes for the image is $(h \times w) \times 8$. See “Download graphics (logo) commands” on page 115 for an example of the data.

Purpose:

To print all-points-addressable print messages.

Remarks:

The margin will be ignored if this causes the logo to overrun the line length.

These messages can be positioned on the page using the commands for setting positions.

Not supported in document landscape mode.

To print graphics on the printers when the data is greater:

1. Hold the buffer.
2. Send all the data.
3. Release the buffer.

Note: When the buffer is held, care must be taken to avoid exceeding the capacity of the printer memory (see Table 23).

Table 23. Buffer sizes

4610 model	Buffer size
Tl1, Tl2	2 KB
Tx3, Tx4, Tx6	16 KB
Tx8, Tx9	64 KB

The left margin will be rounded down to a factor of 8. For example, if the margin = 74, the logo starts at 72.

Retries are not attempted on print errors.

Valid at the beginning of the line only.

When printing in the document station, a line feed command must be sent to advance the paper past the last line of the logo.

If the parameter d , w , or h is out of the defined range for this command, the command is discarded and the remaining data is processed as print data.

This command will increment status byte 6.

If this message is printed on a regular basis, consider downloading it to save communication time. (See “Download graphics (logo) commands” on page 115.)

The data buffer can be used for signature capture.

Print predefined graphics (logo) command

EIA-232 Syntax:

GS / *m logo#* or X'1D2F;*m;logo#*'

where:

m The dot-density:

00 Normal Print - 200 dpi in the receipt station, 150 dpi in the document station.

Note: In the document station, this takes three passes of the print head for a logo that is 8 dots high.

01 Double wide - 100 dpi in the receipt station, 75 dpi in the document station.

Note: In the document station, this takes one pass of the print head for a logo that is 8 dots high.

02 Double wide and high - 100 dpi in the receipt station, 75 dpi in the document station. Every dot row in the vertical direction will be printed twice.

logo # The number associated with the logo that is stored.

- range = 1 to 40 for all models except TI8, TI9, TG8, and TG9
- range = 1 to 255 for Models TI8, TI9, TG8, and TG9

Purpose:

To print predefined all-points-addressable print messages.

Remarks:

The margin is ignored if it causes the logo to overrun the line length. Printing this message in the document station at 150 dpi will take three passes of the print head.

These messages can be positioned on the page using the commands for setting positions.

Valid at the beginning of the line only.

This command is not valid in landscape mode.

This command will increment status byte 6.

Retries will not be attempted on print errors.

In the document portrait station, a line feed command must be sent to advance the paper past the last line of the logo.

See "Download graphics (logo) commands" on page 115.

Print predefined messages

EIA-232 Syntax:

GS ^ *message#* or X'1D5E;*message#*'

where:

message#

The number associated with the stored predefined message.

- range = 1 to 25 for all models except TI8, TI9, TG8, and TG9
- range = 1 to 255 for Models TI8, TI9, TG8, and TG9

Purpose:

To print predefined print messages.

Remarks:

Valid at the beginning of the line only.

Retries will not be attempted on print errors.

Attention: Stored commands can increment status byte 6. See “Predefine messages” on page 117.

Miscellaneous commands

Tab to next tab stop

EIA-232 Syntax:

HT or X'09'

Purpose:

Moves the print position to the next tab stop.

Remarks:

See “Set horizontal tab positions” on page 138.

Tabs are valid when printing is aligned to the left only. If the tabs are used when alignment is not left, results can be unpredictable. (See “Align positions” on page 139.)

Return home (select print head location)

EIA-232 Syntax:

ESC < *n* or X'1B3C;*n*'

where:

n	The print-head position:
00	Document home position
01	Open document throat position. On Models T13, T14, T18, TG3, TG4, and TG8, the DI station throat will automatically be closed if the CR station is exercised. (The Model T19/TG9 throat can not be opened.)
02	Reserved
03	Left home position
04	Refined document home position. This can be used to recover from a home error.
05	Register document <ul style="list-style-type: none"> • Close throat if open • Advance paper forward to first position
06	Re-register the document. If the document is in the printer, it is pulled back to the first print position. Valid for Models Tx8 and Tx9 only.
07-FF	Reserved

Remarks:

Only valid at the beginning of the line. Only valid for impact print stations.

Purpose:

To move the print head to the desired location.

Remarks:

Valid at the beginning of the line only. Valid in impact print stations only.

Paper cut/DI eject

EIA-232 Syntax:

ESC i or ESC m or X'1B69 or 1B;6D'

Purpose:

To cut the paper in the customer receipt station, or eject the document in the document insert station.

Remarks:

- This command is the equivalent of a form feed (OC) in the document insert station but does not feed the customer receipt in the CR station.
- ESC i or X'1B69' *does not* increment status byte 6.
- ESC m or X'1B6D' *does* increment status byte 6.

Generate drive pulse for cash drawer

EIA-232 Syntax:

ESC p m n1 n2 or X'1B70;m;n1;n2'

where:

- m** The cash drawer number - 0 or 1.
- n1** Pulse width on time = (n1 × 2) milliseconds.
- n2** Pulse width off time = (n2 × 2) milliseconds.

Purpose:

To open one of the cash drawers attached to the printer.

Remarks:

Printing will be suspended while a cash drawer is being opened.

Retrieve the flash storage

EIA-232 Syntax:

ESC 4 n1 n2 or X'1B;34;n1;n2'

where:

- n1** One-byte count of the bytes to be returned
- n2** Three-byte address of the first byte to be returned

Purpose:

Retrieve data from user flash storage.

Remarks:

One byte will be returned if a byte count of X'00' is specified.

In many RS-485 printers, the number of bytes retrieved should be kept under 200 to ensure that the system's receive buffer is not overrun.

The valid address range for each SureMark depends on the model number and which memory option, if any, is installed. Use "Retrieve size of user flash storage" on page 162 to determine the valid address range for your printer.

Retrieve size of user flash storage

EIA-232 Syntax:

ESC 4 x '08 FF FF FF' or X'1B;34;08;FF;FF;FF'

Purpose:

Retrieve the size of the user flash storage in the printer.

Remarks:

The size of the user flash storage will be returned in 8 bytes after the printer status bytes. The data will be in the form of ASCII decimal data.

Retrieve printer usage statistics

EIA-232 Syntax:

X'1B 51 xx'

where:

xx The hex value of the requested statistic. See Table 24.

Purpose:

To send printer usage statistics from the printer to the host.

Remarks:

- The usage statistics are sent over the serial line in status bytes 9 and 10. See Table 24 for the values of parameter **xx**.

Use this procedure to retrieve printer usage statistics from the printer:

- Reset the printer. (This is an optional step. It ensures that the most recent counts will be retrieved.)

EIA-232 Syntax:

X'10 05 40'

- Perform the Retrieve Printer Usage Statistics command.
- Multiply the returned value by the factor given in Table 24 to get the actual printer statistic.

Table 24. Retrievable usage data

Hex Value	Usage Data Being Tracked	Factor
6D	Runtime monitoring for image brightness; Runtime monitoring for image contrast (see Note 3)	N/A
6E	Runtime monitoring for image focus (see Note 3)	N/A
70	Manufacture Week Code: <i>ww,yy</i> where <i>2405</i> would be the 24th week of 2005	N/A
80	FRU Card/Invalid usage numbers (set to X'0164' at the factory, not set for FRU logic cards)	N/A
81	Number of paper cuts	32
82	Low byte of the number of characters printed on the CR (thermal) station (see Note 1 and 2)	None
83	High byte of the number of characters printed on the CR (thermal) station (see Note 1 and 2)	None
84	Number of steps performed by the CR paper feed motor (200 steps per inch of paper)	50 000
85	Number of times the customer receipt cover was opened (see Note 2)	None

Table 24. Retrievable usage data (continued)

Hex Value	Usage Data Being Tracked	Factor
86	Number of failed paper cuts - single-station printers only	None
87	Number of characters printed at the DI (impact) station - thermal/impact printers only (see Note 1)	1 000
88	Number of steps performed by the DI paper feed motor	50 000
89	Number of DI transport motor starts	5 000
8A	Number of home errors - thermal/impact printers only (see Note 2)	None
8B	Number of times the DI cover was opened - thermal/impact printers only (see Note 2)	None
8C	Number of forms that were inserted into the DI station - thermal/impact printers only	100
8D	Number of MICR reads - Tx4, Tx8, Tx9	16
8E	Number of high-interference MICR reads	8
8F	Number of failed MICR reads	8
90	Number of check flips performed	16
91	Number of check flip failures	8
92	Remainder value of CR motor steps (from 0x84) (see Note 2)	None
93	Remainder values of paper cuts (from #0x84) (see Note 1 and 2)	None
94	Remainder values of DI characters printed (from #0x87) (see Note 1 and 2)	None
95	Remainder values of DI paper feed motor steps (from #0x88) (see Note 2)	None
96	Remainder values of forms inserted into DI station (from #0x8C) (see Note 2)	None
97	Remainder values of DI transport motor starts (from #0x89) (see Note 2)	None
98	Remainder values of check flip failures - Tx4, Tx8, Tx9 (from #0x91) (see Note 2)	None
99	Remainder values of failed MICR reads - Tx4, Tx8, Tx9 (from #0x8F) (see Note 2)	None
9A	Remainder values of check flips performed - Tx4, Tx8, Tx9 (from #0x90) (see Note 2)	None
9B	Remainder values of MICR reads - Tx4, Tx8, Tx9 (from #0x8D) (see Note 2)	None
9C	Remainder values of high interference MICR reads - Tx4, Tx8, Tx9 (from #0x8E) (see Note 2)	None
9D	Remainder values of bar codes printed (from #0xD8) (see Note 2)	None
9E	Remainder values of scanned documents - Tx8, Tx9 only (from #0xD3) (see Note 2)	None
9F	Remainder values of cash drawer successful (from #0xD6) (see Note 2)	None
D2	Number of flash erase commands performed (NVRAM write count) (see Note 2)	None

Table 24. Retrievable usage data (continued)

Hex Value	Usage Data Being Tracked	Factor
D3	Number of checks scanned - Tx8, Tx9 only	16
D4	Check Quality Count: the number of times a scanned check fails quality measurement - Tx8, Tx9 only (see Note 2)	None
D5	Tone Sounded Count: single station printers only	32
D6	Cash drawer opened successful count (see Note 2)	16
D7	Cash drawer failed to open count (see Note 2)	None
D8	Number of Bar Codes printed	32
D9	Number of times the maximum temperature of either motors or print heads has been reached (see Note 2)	None
DA	Remainder value of Tone Sounded Count, single station printers only (see Note 2)	None
<p>Notes:</p> <ol style="list-style-type: none"> 1. The number of printed characters is based on the number of dots that were printed, assuming 64 dots per character for thermal characters and 16 dots per character for impact characters. 2. Reads from these values will add in the values that have accumulated since the last store to FLASH. These values will be added into the "Remainder" MCTs when one exits. 3. Retrievable usage data, 6D and 6E, are the runtime monitoring variables for the image quality produced by the scanner. The variables monitored are Image Brightness (the high byte of 0x6D), Image Contrast (the low byte of 0x6D), and Image Focus (the high byte of 0x6E). The low byte of 0x6E is reserved for future use; it is set to 0xFF. The maximum value is 127; they are a running average of the quality of the scanner. On a new calibrated scanner, the brightness and contrast values will be ~120 and the focus will be ~105. A bad scanner or a scanner in need of calibration would have values of 90 for brightness and contrast and 77 for focus. If the scanner is recalibrated these values will be reset. The offline MICR test will report back if a given scan has values outside of normal range. 		

Check processing commands (Models TI2, TI4, TI8, TI9, TG4, TG8, and TG9 only)

This printer can process the check entirely without taking it from the printer. It can read the magnetic ink character line, frank the back of the check, and flip the check to print the face of the check.

Note: To print the face of the check, select the document station in landscape mode as the print station.

Models TI8 and TI9 MICR read commands

Note: Model TG8 is equivalent to TI8 and TG9 is equivalent to TI9.

The Models TI8 and TI9 have two MICR read commands. The X'1B49' command, which is used in the Model TI4 printer and the MICR command X'1B3E01', which also scans a check. Both commands use the OCR decoding algorithm for reading the MICR line, which is available on these models.

MICR read

EIA-232 Syntax:







ESC I or X'1B49'



Purpose:

To read account information from the magnetic ink character line on customers' checks.

Remarks:

- Checks should be inserted upside-down from the front and against the right wall of the printer. The check can be, but does not have to be, registered in the printer before this command is given. The check will be fed, forward, until the bottom sensor is uncovered, then fed back for the MICR reader reading. After the reading is complete, the check is fed to the first print position.
- This command increments the line count (status byte 6).
- At the completion of this command, information read by the MICR reader is sent over the serial I/O following the eighth status byte.
- The next byte represents a percentage of an average signal level of the MICR characters for the E13b check only. (In CMC7, this byte is always 100.) A nominal signal has a strength of 100.
- Characters are sent as read from left to right, up to a maximum of 65 characters.
- If no magnetic ink characters are detected, a single question mark (X'3F') is sent back.
- If the printer is unable to read any character on its first try, it will feed the check forward and backward for a second try. Complete status will then be sent to the system - if the character was still not read it will be identified by a single question mark (X'3F').
- Checks with magnetic ink printing within 1.2 inches of the right edge of the check are not read correctly. This occurs when the amount field is printed on the check.

Character	Description	ASCII Representation	hex value returned
MICR data representation			
0-9	Numerical data	0-9	30-39
	blank		20
	Unreadable Character	?	3F
E13-B - Special characters			
	Dash	-	2D
	Transit	T	54
	On Us	A	41
	Amount	\$	24
CMC7 - Special characters			
	Special character 1	a	61
	Special character 2	b	62

Character	Description	ASCII Representation	hex value returned
	Special character 3	c	63
	Special character 4	d	64
	Special character 5	e	65

Error Conditions:

Document feed error (status byte 7). This bit is set if the inserted check is too long. The maximum check length is 10 inches. The error is also set if the check does not clear the document sensor when expected.

Flip check

EIA-232 Syntax:

ESC 5 or X'1B35'

Purpose:

To flip the check after a MICR read. This will allow the face of the check to be printed.

Remarks:

- Set print station to document landscape mode to print the face of the check as it comes out of the flipper mechanism.
- This command increments the line count (status byte 6).

Error Conditions:

Document feed error (status byte 7). This bit is set if the inserted check is too long. The maximum check length is 10 inches. The error is also set if the check does not clear the document sensor when expected.

Document scanner commands

Scanner commands are supported on SureMark printer Models T18, T19, TG8, and TG9 only.

Start scan

EIA-232 syntax:

X'1B;3E;n'

where:

- n* = **00** optical scan only, document is ejected
- n* = **01** scan and MICR/OCR read
- n* = **02** optical scan and re-read document (Models T19/TG9 only)
- n* = **03** scan, MICR/OCR read, and prepare for flip (start the check into the flipper)
- n* = **04** partial scan, MICR/OCR, and prepare for flip (start the check into the flipper)

Remarks:

- Pulls in document present at scanner input.

- Document image is retained in RAM until another scan command is received, or the printer is reset.
- Set the dots per inch (DPI) and file compression type prior to scanning. The printer begins to compress immediately after scanning. There, changing the compression type after scanning would make the check process take much longer as it now has to compress twice if the compression type changes.
- Successful read returns status with status byte 05, bit 06 set, and a 2-byte image width, and a 2-byte image height and 2-byte image width (in hundredths of an inch) follows the status.
- When using the X'01', X'03', or X'04' option, the MICR data is returned after the successful scan status, and matches the format in the MICR command section.
- If the scan is not successful, the Document feed error bit is returned (status byte 7, bit 7).
- When using the X'03' or X'04' option, the check will only start into the flipper for personal check (~6 in.). Otherwise, it will function the same as X'01'. With the check partially in the flipper mechanism, the printer can print in the portrait station or flip the document. If any other command is received at this point, the document must come fully out of the flip mechanism and be re-readied.
- Image Quality detection will be run on the quality of the image scanned and if the image "fails" the Image Quality test an error bit will be set in the header information of the retrieved image.
- When only a partial image or no image is required, the X'04' command will take less time than the X'01' or X'03' options.

T18/TG8 printer

- X'00' and X'02' options: scans the full document and ejects the document out the top.
- X'01', X'03', and X'04' options: the bottom 1.5 in. of the document is not captured in the scanned image.
- X'03' and X'04' options: the document is less than 6.5 in.; it is fed into the flipper while reading the MICR line.

T19/TG9 printer

- X'00' option: scans the full document and ejects the document out the top.
- X'01' option: scans the entire document, reads MICR and re-readies the document.
- X'02' option: scans the check and re-readies the document.
- X'03' option: scans the entire document and if the document is less than 6.5 in., it is fed into the flipper while reading MICR line.
- X'04' option: scans a partial document (bottom 1.5 in. not scanned) and if the document is less than 6.5 in., it is fed into the flipper while reading the MICR line.

Check 21 flow - with the T19

Assume that the check must be fully filled out and both the front and back of the check imaged. Assume the printer prints the check face information.

1. Customer gives signs the check and gives it to the cashier.
2. Cashier is prompted to insert the check to be imaged.
3. The check is inserted face down. The MICR is read with '1B, 3E, 04.'

4. The transaction information (MIRC, amount, and so on) is sent to the host for approval. The rest of flow is based on successful approval.
5. Back of the check is franked.
6. Flip and scan the back of the check. Select landscape print station, flip, and scan. (1B 63 30 08 1B 35 1B 3E 02)
7. An image of the check back is read and stored.
8. The face of the check is printed.
9. Flip and scan the front of the check (1B 35 1B 3E 03).
10. An image of the check face is read and stored.
11. Flip the check. (1B 35)
12. Print the face of check **with void** and eject. (VOIDx"0c")

Assume that the customer fills out the check.

1. Customer fills out and signs the check and gives it to the cashier.
2. Cashier is prompted to insert the check to be imaged.
3. Check is inserted, face down. Check is scanned and MICR is read with the option (1B, 3E 03).
4. Transaction information (MICR, amount, and so on) is sent to the host for approval. The remaining flow is based on successful approval.
5. Image of the check face is read and stored.
6. Check is franked.
7. Flip and scan the back of the check. Select landscape print station, flip, and scan. (1B 63 30 08 1B 35 1B 3E 02)
8. Image of the check back is read and stored.
9. Check is printed on the face of the check with **void and ejected**. (VOIDx"0c")

Print scanned image

EIA-232 syntax:

X'1B;30;n1;x;y;dx;dy;s1;s2;n2'

where:

- | | |
|---------------|---|
| <i>n1</i> | 2 bytes, reserved, X'00 00' |
| <i>x,y</i> | 2 bytes each, top-left corner of area to be printed |
| <i>dx, dy</i> | 2 bytes each, offset in the x and y direction respectively, to be included in the print area |
| <i>s1</i> | 1 byte, percentage to scale image in the x direction (A value of 100 or 0 results in no scaling.) |
| <i>s2</i> | 1 byte, percentage to scale image in the y direction (A value of 100 or 0 results in no scaling.) |
| <i>n2</i> | print options, bit 0; value 0 = do not rotate, value 1 = rotate 90 degrees counterclockwise |

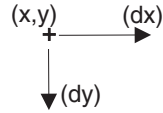

Figure 51. Scanned image layout

Remarks

Image location (*n1*) of 0 prints the most recently scanned image to the thermal station.

The top-left corner of the scanned document is used as the point of reference. All *x*, *dx*, *y*, and *dy*, values are based on 0.01 inch. The paper movement path is the *y* axis, and the scan head dot row is the *x* axis.

In all cases, *dx* and *dy* define the area's width to the right, and height down. If *dx* and *dy* extend the printer area further than the boundaries of the image, the value is truncated to the image boundary. If the size of the print area is greater than the thermal print head can print (either from image size or scaling), the image is truncated to the width of the print head. The only scaling options are 100% (no scaling) and 200% (double). Tag data included with the image is not printed.

If the image is stored in JPEG format, then graphics printing is not supported.

Store scanned image and/or select partial image for retrieval

EIA-232 syntax:

X'1B;41;n1;x0;y0;dx0;dy0;x1;y1;dx1;dy1;x2;y2;dx2;dy2;x3;y3;dx3;dy3;tagdata'

where:

***n1* Select storage method, one byte**

- X'00' store entire image
- X'01' store image using template 1
- X'02' store image using template 2
- X'03' store image using user defined values
- X'11' Compress a section and keep in RAM using user defined values (*x0*, *y0*, *dx0*, *dy0*)

x0*, *y0 2 bytes each, top-left corner of area to be stored

dx0*, *dy0

2 bytes each, offset in the *x* and *y* direction respectively, to be stored

x1*, *x2*, *x3*, *y1*, *y2*, *y3

2 bytes each, corresponding offset in the *x* and *y* direction to define size of subblock to store

tagdata

ASCII string terminated by null character, maximum 100 characters

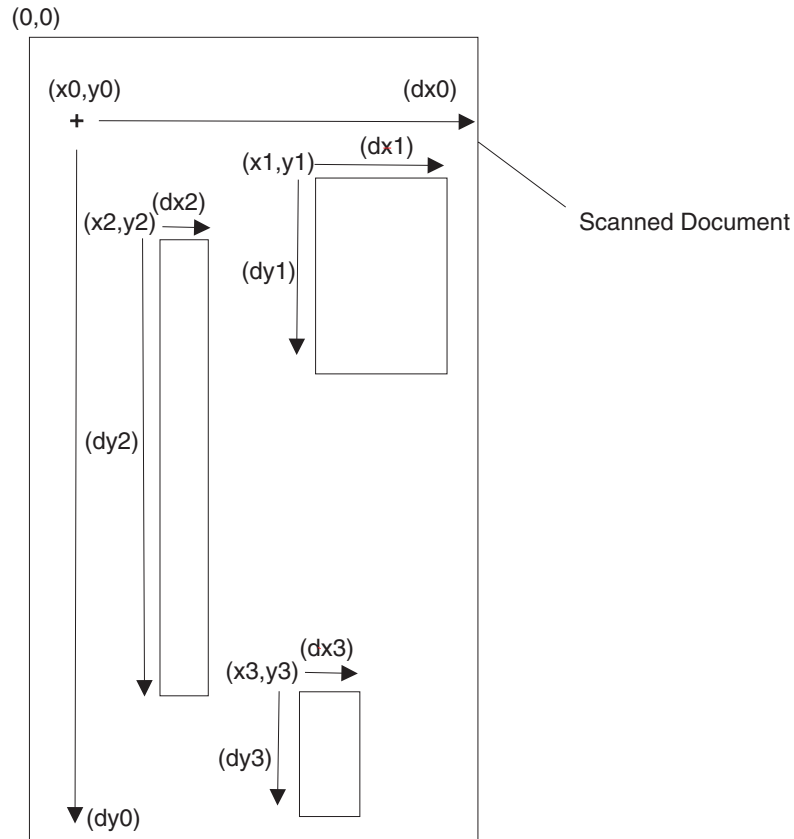

Figure 52. Scanned image organization

Remarks:

Images are stored sequentially. The locations where the images are stored are obtained with a *Retrieve next table location* command before issuing the *store* command. The image is compressed using the compression algorithm last selected by the *Select compression format* command, and is then stored in memory.

When storing an image, the user can elect to store the entire image within the defined area, or just selected blocks within the defined area. Saving selected blocks reduces storage use, but keeps related data together. When storing multiple blocks of data, each block gets a unique storage location. A byte in the header message indicates that the block is part of a group. The first half-byte indicates which block of the group it is, the second half-byte indicates the number of blocks in the group. If the byte returned is X'14', then the block is the first of a group of four. All blocks contain header information, but only the first block in a group contains tag data.

The *Select storage method* byte ($n1$) defines how the image should be stored.

When $n1 = 0$, all data defined by $x0, y0, dx0, dy0$ is stored. The command parameters, $x1, x2, x3, y1, y2, y3, dx1, dx2, dx3$, and $dy1, dy2, dy3$ should not be included.

When $n1 = 1$, a predefined template, based on a personal check is used to store the image. The area defined is the entire personal check, however the name/address and the MICR blocks are saved. The command parameters, $x0, x1, x2, x3, y0, y1, y2, y3, dx0, dx1, dx2, dx3$, and $dy0, dy1, dy2, dy3$

should not be included. These parameters are defined in MCT locations X'0xB0' through X'0xBF' and can be viewed or adjusted using the MCT Read and MCT Write commands. If fewer than four blocks are required, a block can be disabled by storing a value of X'FFFF' for a coordinate MCT location. The block is then ignored.

When $n1 = 2$, a predefined template, based on a business check is used to store the image. The area defined is the entire business check, however only the name/address, and MICR blocks are saved. The command parameters, $x0, x1, x2, x3, y0, y1, y2, y3, dx0, dx1, dx2, dx3$, and $dy0, dy1, dy2, dy3$ should not be included. These parameters are defined in MCT locations X'0xC0' through X'0xCF' and can be viewed or adjusted using the MCT Read and MCT Write commands. If fewer than four blocks are required, a block can be disabled by storing a value of X'FFFF' to a coordinate MCT location. The block is then ignored.

When $n1 = 3$, this method allows the user to define subblocks of data to store. All command parameters must be sent. If fewer than four blocks of data are to be saved, the value of X'FFFF' must be sent for unused parameters. The top-left corner of the scanned document is used as the point of reference. All xn, dxn, yn , and dyn values are based on 0.01 inch. The xn command parameters are horizontal offsets from the left side of the scanned document. The yn parameters are vertical offsets from the top of the scanned document. The dxn and dyn parameters define the width and height, respectively, of the defined area or block.

When $n1=0x11$, this command allows the user to obtain a partially scanned image without having to spend time storing it into Flash. Since the command does not destroy the original scanned image, successive commands using $n1$ of 0x11 is possible. Executing this command will compress a partial image of the check using the user defined values defined in $x0, y0, dx0, dx1$. The new image will be stored in RAM location 0. Though the command does not technically store the image into flash, upon compressing the partial image check, Bit 7 of Status byte 3 will be set to true to comply with the existing Store Scanned Image commands.

The printer attempts to determine the width and height of the document, and returns the value when the document is scanned. If the value of xn plus dxn is greater than the total width scanned by the printer, the printer uses the data detected up to the maximum scan width. If the value of yn plus dyn is greater than the length of the document, the printer uses blank (white) data to fill the area to the lesser of the $yn+dyn$ value, or maximum document length allowed.

If yn or xn is greater than the maximum allowed, the command is rejected. If $x1$ and $y2$ extend the printer area beyond the boundaries of the image, the values are truncated to the image boundary.

Errors:

Status byte 3 is set:

- When the image to be stored is larger than the remaining unused memory for the image boundary.
- If an error occurs during the flash write (hardware error).

Example 1:

Method 0: X'1B 41 00 00 19 00 32 01 13 02 26 30 33 2F 30 34 2F 30 32 20 30 30 31 2E 33 34 00'

An image 2.75 in. by 5.5 in. that begins 0.25 in. from the left side, and 0.5 in. from the top of the document is stored with the tag data: 03/04/02 001.34

Example 2:

Method 3: X'1B 41 03 00 AF 01 DB 00 28 00 64 00 B4 00 64 00 64 00 96 00 96 00 64 00 19 01 13 FF FF FF FF FF FF FF FF 00'

Three separate areas are stored. No tag data is included. Table 25 provides details.

Table 25. Data table

Document width = 3 in.	Document height = 6 in.
x0 = 1.75 in.	y0 = 4.25 in.
dx0 = 0.40 in.	dy0 = 1.0 in.
x1 = 1.80 in.	y1 = 1.0 in.
dx1 = 1.0 in.	dy1 = 1.50 in.
x2 = 1.50 in.	y2 = 1.0 in.
dx2 = 0.25 in.	dy2 = 2.75 in
x3 = not applicable	y3 = not applicable
dx3 = not applicable	dy3 = not applicable

Tag data, stored with the image, allows the user to include additional information about the image. It must be an ASCII string, terminated by a null character.

Example 3:

Method 0x11-Compress partial check image defined by user: X'1B 41 11 00 00 00 00 00 64 00 C8 00'

Retrieve the image using Retrieve Scanning Image command X'1B 39 00 00'

Method 0x11-Compress another part of the check image: X'1B 41 11 00 64 00 C8 00 64 00 C8 00'

Retrieve the image using Retrieve Scanning Image command X'1B 39 00 00'

Retrieve scanned image

EIA-232 syntax:

X'1B;39;n1;n2;n3'

where:

- *n1*, 2 bytes, Image location to retrieve
- *n2*, 4 bytes, Offset into image from which to retrieve data
- *n3*, 2 bytes, Number of bytes to retrieve

Remarks:

Image location (*n1*) of 0 returns the image last scanned. To return just a part of the image from RAM, compress the partial image using Store Scanned Image and/or select partial image for retrieval first. Offset (*n2*) and size (*n3*) of 0 retrieve the header information for the specified image. When *n1* = 0, the header consists of the 12 data bytes and a null character for the

tag data. In this case, only the Compression, Size1, and Size2 fields contain data. The header has the following format:

- Status; 1 byte
 - Bit 7, Image read; 1 = image has been read, 0 = image has not been read
 - Bit 6, 1= IQD (Image Quality Detection) Error
 - Bits 5–0; Reserved
- Compression; 1 byte
 - Bits 7–5; Reserved
 - Bits 4–0; Algorithm used to compress image. See “Select compression format and scanned image threshold” on page 174 command
- Size1; 4 bytes
 - Number of bytes in image, not including tag data.
- Size2; 4 bytes (x1, y1)
 - Width of image in the x direction (in hundredths of inch increments), 2 bytes

Note: Scanner resolution is 200 dots per inch.

- Height of image in the y direction (in hundredths of inch increments), 2 bytes
- Block position; 1 byte
 - Lower four bits indicate the number of blocks that were saved for the image.
 - Upper four bits represent the current block number.
- Future; 1 byte
 - Reserved
- Tag data
 - ASCII data supplied by the application, terminated by a null string.

Offset ($n2$) = X'FF FF FF FF' with size ($n3$) = X'FF FF'sets to 0 the Image Read bit in the specified image header.

For stored images ($n1>0$), the image data format is the format that was active when the image was stored.

For immediate images ($n1=0$), the image data format is the currently selected format.

Error conditions:

If any parameter is out of range, Command Reject is returned.

Scanner calibration

EIA-232 syntax:

GS c 0 or X'1D 63 30'

Purpose:

Used to initiate the calibration routine for the scanner. The printer scans the document multiple times and updates the printer's calibration data. See “Document scanner calibration (Models T18, T19, TG8, TG9)” on page 60 for more information about the document to be used.

Retrieve next image location

EIA-232 syntax:

GS N SOH NULL or X'1D 4E 01 00'

Remarks:

Returns the table position where the next image is stored. Command is *Extend MCT Request* command (2-byte address). Status byte 5, bit 3 is set to indicate data is attached.

Retrieve first unread image location

EIA-232 syntax:

GS N SOH SOH or X'1D 4E 01 01'

Remarks:

Stored images are searched sequentially, and the first location that has not been set to "read" is returned. The command is *Extend MCT Request* (2-byte address). Status byte 5, bit 3 is set to indicate data is attached.

Select compression format and scanned image threshold

EIA-232 syntax:

X'1B;4d;x;n1;n2'

where:

- x = X'1F'
 - address to store data
- n1
 - 00 200 DPI TIFF-CCITT-Group 4 compression
 - 01 200 DPI JPEG compression
 - 02 200 DPI BMP (uncompressed)
 - 04 200 DPI TIFF file, no compression (gray scale)
 - 10 100 DPI TIFF-CCITT compression (black and white)
 - 11 100 DPI JPEG compression (gray scale)
 - 12 100 DPI BMP (uncompressed gray scale)
 - 14 100 DPI TIFF File (no compression)
- n2
 - Lightens or darkens the contrast of a scanned image. Higher numbers print darker.

Remarks:

The current format applies to retrieval and storage of the currently scanned image. Changing the format does not change the format of any images already stored in flash. The setting is persistent across reset and power cycles.

Table 26. Average size for a personal check with little background data

Compression type	Size
00 - TIFF-CCITT compression - 200 DPI	5K Bytes
01 - JPEG compression - 200 DPI	45K Bytes
02, 04 - no compression - 200 DPI	660K Bytes
10 - TIFF-CCITT - 100 DPI	3.5K Bytes

Table 26. Average size for a personal check with little background data (continued)

Compression type	Size
11 - JPEG compression - 100 DPI	15K Bytes
12, 14 no compression 100 DPI	170K Bytes

Asynchronous (real-time) commands

These commands are processed as soon as they are received. They do not go into the printer buffer.

Note: These commands are not recognized when they occur in the middle of another command. For example, sending this command after the second byte of a 3-byte command, as in ESC J n.

Real-time requests

EIA-232 Syntax:

DLE ENQ *m* or X'1005:n'

where:

- m** Specifies the ASCII command character
- n** Specifies the hexadecimal command character

m	n	Description
1	31	Release the print buffer for printing. This should be sent after an error has occurred and the print buffer is held. If an error occurred during the transaction that was being held, the printer sends back the line number with the error and the error status. The system can then decide to cancel or continue printing after the error is corrected. The system uses this command to continue printing after the error is corrected.
2	32	Cancel print buffer. This clears the print buffer of all data. In EIA-232 mode, the user must wait for buffer empty status (status byte 2, bit 6) before sending any more commands. Note: A status message is returned immediately after execution of this command.
3	33	Undefined.
4	34	EC request - transmit printer status. Sends the printer's status to the system. This command does not go into the printer's data buffer but is processed immediately. The printer status is returned in status bytes 1–8. See "Status summary" on page 184 for more information. Status byte 5, bit 1, will be set after the EC request has been executed.
5-8	35-38	Undefined
@	40	Reset the printer. The printer stops what it is doing and goes through its reset routine. The print buffer is canceled and all commands erased. All printer settings go back to default values.

m	n	Description
A	41	Enable unsolicited status. Note: A status message is returned immediately after execution of this command. To enable these status messages, the Status Sent to System setup command must be enabled. See “Status sent to system” on page 141.
B	42	Disable unsolicited status
C	43	Disable transparent XON/XOFF

Purpose:

To process a command immediately.

Remarks:

Either the *Release print buffer* or the *Cancel print buffer* command must be used in these situations:

- When recovering from a cash receipt print error
- After clearing an unrecoverable home error

After the printer resets, it defaults to **not** sending status unless requested. If an error occurs, the printer appears hung, unless a status is requested. If unsolicited status is enabled, the printer sends the error to the system as soon as it occurs.

Note: If transparent XON/OFF is disabled, X'10', X'11', and X'13' can be imbedded in returned status and data. (See “XON/XOFF control” on page 29.) To re-enable the printer, the printer must be reset.

Data buffer management and batch printing

Reset line count

EIA-232 Syntax:

ESC 6 or X'1B36'

Purpose:

Resetting the line count lets the system track the print line where an error occurs.

Remarks:

The line count is incremented at every print command. The count is sent in every status message to the system. The count can go to 256 (X'FF'), when it rolls back to 0. (See “Print character commands” on page 156.)

Disable line count

EIA-232 Syntax:

ESC 8 *n* or X'1B;38'*n*

where

- *n* = 1, disable line count
- *n* = 0, enable line count

Purpose:

To temporarily not increment the line count. This can be used when printing predefined messages, if the number of lines embedded in the message is unknown.

Hold printing until buffer is released

EIA-232 Syntax:

ESC 7 or X'1B37'

Purpose:

If the system can not send data to the printer at a speed needed to keep the printer in constant motion, it can hold the printer queue until it sends all data lines for a transaction.

Remarks:

The printer must be printing one line while processing the next line. If the printer is unable to completely process a line, the print speed reduces to half.

The line count is reset when the buffer is held.

Page mode printing commands

Note: Not supported on the T11 and T12.

Select page mode

EIA-232 Syntax:

ESC L or X'1B;4C'

Remarks:

- Enables page mode printing.
- Supported on thermal station only.
- Starting position is set by *Set printable area X'1B;57..'* and *Set print direction X'1B;54..'* commands.
- Intercharacter spacing X'1B;20;n' and line spacing X'1B;31', X'1B;32', X'1B;33' commands are set independently for page mode and standard mode.
- The following commands are allowed:
 - Rotate characters
 - Set alignment
 - Set/Clear upside-down
 - Set margins

Select standard mode

EIA-232 Syntax:

ESC O or X'1B;4f'

Epson emulation syntax:

ESC S or X'1B;53'

Remarks:

- This command is effective in page mode only.
- Data buffered in page mode is cleared.
- This command sets the print position to the beginning of the line.

Select printable area

EIA-232 Syntax:

ESC X or X'1B;58;x;y;dx;dy'

where:

- *x, y*
 - Two-byte horizontal and vertical starting position (in dots)
- *dx, dy*
 - Two-byte horizontal and vertical printing area (in dots)

Remarks:

- When sent in standard mode, this command sets the printable area for page mode, but has no effect on standard mode printing.
- If the starting position (*x, y*) is outside the maximum range, the entire command is ignored.
- If the printing area is defined outside the maximum page size, the printing area is limited to the page size.
- Maximum page size is 576 dots in the horizontal direction, and 800 dots in the vertical direction (except Models Tx8 and Tx9, which is 1250 dots in the vertical direction).

Select printing direction/position

EIA-232 Syntax:

ESC T *n* or X'1B;54;n'

where:

n

Table 27. Print direction

<i>n</i> =	Direction / position
X'00'	Left to right / top left
X'01'	Bottom to top / bottom left
X'02'	Right to left / bottom right
X'03'	Top to bottom / top right

Remarks:

When sent in standard mode, this command sets the print direction for page mode, but has no effect on standard mode printing.

Starting position is within the printable area defined by the *Select printable area* command (X'1B;58...)'.

Set vertical position

EIA-232 Syntax:

GS \$ *y* or X'1D;24;y'

where:

y is a two-byte vertical printing position (in dots)

Remarks:

- Applies to page mode only.

- Moves the printing position to the specified dot position perpendicular to the printing direction specified by the *Select printing direction* command. If printing direction is bottom-to-top, or top-to-bottom, this command adjusts the printing position in the horizontal direction.
- If the value of *y* is outside the specified printable area, this command is ignored.

Set relative vertical position

EIA-232 Syntax:

GS \ *y* or X'1D;5C;*y*'

where:

y is the two-byte vertical printing position (in dots).

Remarks:

- Applies to page mode only.
- Moves the printing position the specified number of dots from the current print position, in the direction perpendicular to the printing direction specified by the *Select printing direction/position* command (X'1B;54...'). If the print direction is bottom-to-top, or top-to-bottom, this command adjusts the printing position in the horizontal direction.
- If the value of *y* is outside the specified printable area defined by the *Select printable area* command, this command is ignored.
- If *y* is a negative value, the current print position will move in the opposite direction.

Set left margin position (standard mode), set absolute print position (page mode)

EIA-232 Syntax:

ESC \$ *n1 n2* or X'1B;24;*n1;n2*'

where:

- *n1* is the high-order byte of the dot offset from the beginning of the print line.
- *n2* is the low-order byte of the dot offset from the beginning of the print line.

Default:

n1 = 0, *n2* = 0

Remarks:

- In the thermal station, 1 mm = 8 dots.
- In the impact station, 1 inch = 150 half-dots (75 dots).
- *n1* and *n2* are hex values. Convert each to decimal, and use this formula to get the decimal equivalent: (*n1* x 256) + *n2*.
- The maximum value in the thermal CR station is 576. The maximum value in the impact DI station is 474.
- In the CR station, this number is rounded back to a factor of 8.
- If the *n1,n2* value exceeds the maximum, it is ignored.
- This command should be sent only after the command that selects the station, *Set print station* (ESC *c1 n*).
- In Page mode, the printing position is moved the specified number of dots from the beginning of the print line, in the same direction as printing,

specified by the *Select printing direction/position* command (X'1B;54...'). If the print position is bottom-to-top, or top-to-bottom, this command adjusts the print position in the vertical direction.

- This is a one-time adjustment on the current line. If this command moves the print position outside the printable area specified by the *Select printable area* command, it is ignored.

Set relative horizontal position

EIA-232 Syntax:

ESC <5C>h *n1 n2* or X'1B;5C;*n1;n2*'

where:

- *n1* is the high-order byte of the dot offset, relative to the left margin in standard mode or the current print position in page mode.
- *n2* is the low-order byte of the dot offset, relative to the left margin in standard mode or the current print position in page mode.

default:

n1 = 0, *n2* = 0

Remarks:

- In the thermal station, 1 mm = 8 dots.
- In the impact station, 1 inch = 150 half-dots (75 dots).
- *n1* and *n2* are hex values. To get the decimal equivalent, convert each to decimal, and then use this formula: (*n1* x 256) + *n2*.
- To move the position to the left, use a negative number.
- If this number plus the left margin exceeds the printable area, the command is ignored.
- In the CR station, this number is rounded back to factor of 8. See the *Set left margin position* command for more information.
- When printing in page mode, this is a one-time adjustment on the current line. If this command moves the current print position outside the printable area defined by the *Select printable area* command, the command is ignored.

Set printing position

EIA-232 Syntax:

GS] *x y* or X'1D;5D;*x;y*'

where:

- *x* is the two-byte horizontal position, with respect to the paper, regardless of printing direction.
- *y* is the two-byte vertical position, with respect to the paper, regardless of printing direction.

Remarks:

- This command allows complete control of the printing position with a single command.
- If either parameter is outside the printable area defined by the *Select printable area* command, the command is ignored.

Print and form feed and cut the paper

EIA-232 Syntax:

FF or X'0C'

Epson compatibility syntax:

FF or X'0C'

Remarks:

- In standard mode, the data in the print buffer feeds the paper in the CR station or DI station by a preset amount, until the document exits the feed rollers. If a cutter is available (CR station only), it cuts the paper.
- In page mode, the printer prints the page, then returns to standard mode. The page loaded in the printer's buffer is cleared. The paper is not cut.

Print page in page mode

EIA-232 Syntax:

ESC FF or X'1B 0C'

Epson compatibility mode:

ESC FF or X'1B 0C'

Remarks:

- In standard mode, this command is ignored.
- In page mode, this command prints the page that is loaded in the printer. The page remains loaded in the printer's buffer and the printer remains in page mode. This should be used for repeatedly printing the same page, or if there is a template that is filled in with each printout.

Clear print data in page mode

EIA-232 Syntax:

CAN or X'18'

Remarks:

This command deletes all print data in the current printable area of the page stored in the printer's buffer.

Document handling

To read checks, insert them from the front of the printer. Use the side load capability only for documents that must be positioned to begin printing at a particular location on the document. (There is an arrow on the side of the cover to indicate where printing begins.) Use front load for all other cases.

Portrait mode

This is a suggested method of document handling:

1. ESC f (x) (y): Set up document wait time

- x Time the printer should wait from receiving a print line for the document station until the document is inserted.

If the document has not been detected by the time the wait time ends, a document error is sent to the system but the system continues to wait for a document to be inserted.

- y Delay from the time the document is detected until it is *grabbed* by the printer (the start of document printing):
 - Side insertion - closes the document throat.
 - Front insertion - pulls the document into the printer and feeds it to the Top of Form.

2. ESC c 0 X'04': Select document station - normal print mode:

The document present indicator blinks until a document is detected, when it stays on continuously.

- If the document is inserted from the front, it is fed to the first print position after the document wait time. Then commands in the printer buffer begin executing.
- If the document is inserted from the side, printing starts at the location where it was inserted.

(The document throat must be open to insert the document from the side.) Manually, open the throat by pressing and then releasing both buttons. You can also open it with these commands - ESC q or ESC < X'01'.

If a document is not detected within the wait time (specified in the ESC f command), the printer sends error status to the system, and continues to wait.

Notes:

1. The system can either cancel the print buffer, thereby deleting all data in the print buffer, or wait for a document to be inserted.
2. Models T19/TG9 do not support side insertion. Alignment to a particular line can be done using the buttons and the reverse line feed command.

The printer appears to be hung until an action is taken.

3. Send print lines to be printed in this station.

4. Final handling.

You have an option on final handling, finish printing and either eject the document or open the document throat to allow manual removal of the document:

FF: Print and Eject Document.

Finish printing and eject the document.

Landscape mode

Landscape mode printing is primarily for printing the face of a check.

Notes on landscape printing:

- Lines you send to print start at the bottom of the form, against the right stop, and continue to the top of the form, to a maximum of 80 mm from the bottom of the form. This is because the bottom of the form is known (against the right stop) and the top of the form is unknown to the printer.
- Different lengths of paper allow different print-line lengths. Therefore, the application must know the size of the print line.
- The printer calculates the length of a document it is to print. To do that, it must feed the document up past the bottom sensor and back to the top sensor. (On a 5-inch document this takes 2 seconds.) If a MICR read was done previously, the length was calculated at that time.

- When landscape mode is used without the check flipper, the document should be inserted so that the right edge is at the top of the printer, and the bottom edge is against the printer's right wall.
- To position the printing in landscape mode to the correct position, the system must send line feeds. The printer assumes that the top of form for a document in landscape mode is the far left edge of the document (to a maximum of 80 mm from the bottom of the form).
- Line feeding is 5 steps per mm or 21 steps per line, at 6 lpi.
- All landscape printing must be done with one printing pass. Therefore:
 - Double-high printing is not allowed.
 - User-defined characters greater than 9 dots high are not allowed.
- There is no error recovery for landscape printing.
- Set print station to document landscape mode to print the face of the check as it comes out of the flipper mechanism.

Landscape printing commands

1. ESC f (x) (y): Set up document wait time

Same as for portrait mode.

2. ESC c 0 X'08': Select document station - landscape print mode:

A If the document was not previously loaded:

- The document present indicator blinks until a document is detected.
- Once detected, the document will be *grabbed* by the printer and fed to the right margin on the document. Because the document is inserted on its side, this is at the top of the printer.
- If a document is not detected within the wait time (specified in the ESC f command), the printer sends error status to the system, and continues to wait.

The system can either cancel the print buffer, deleting all data in the print buffer, or wait for a document to be inserted.

The printer appears to be hung until an action is taken.

B If the document was previously loaded, the printer feeds the paper to the right margin on the document.

3. Send print lines to be printed in this station.

The number of characters that can be printed on a line depends on the width of the document. The print area is:

- 63 mm high, starting 17 mm from the bottom of the document
- The entire width of the document less 34 mm from the right edge and 10 mm from the left edge

4. Final handling.

You have an option on final handling, finish printing and either eject the document or open the document throat to allow manual removal of the document:

4a. FF: Print and Eject Document.

Finish printing and eject the document.

4b. ESC q or ESC < X'01': Open Document Throat

Finish printing and release the document from the printer's rollers.

Note: The document station stays selected. The printer will wait for another document until the station is changed.

Status summary

Status is sent to the system for:

- Cash receipt print error. The cover is open or out of paper.
- Printer buffer empty. If enabled, see “Status sent to system” on page 141.
- Document sensor state changed. If enabled, see “Status sent to system” on page 141.
- Cash drawer sensor change. If enabled, see “Status sent to system” on page 141.
- Command has timed out. The printer is waiting for additional bytes to complete the command.
- Nonrecoverable home error.
- Document not inserted after document station was selected.
- Document has exited sensor before document print is finished.
- Flash EPROM load error.
- Memory sector is full.
- Flash Storage is full.
- Printer ID request (extended address command).
- MICR read command.
- MCT read command.
- Flash read command.
- Print buffer being held.
- Ribbon cover sensor change.
- Document feed error.

Message from the printer

A message from the printer has this format:

Bytes Contents

- 1 - 2** Data count (X'000A' to X'00FF'). The data count includes the two data-count bytes.
- 3 - 10** Status bytes 1-8. See the descriptions of each byte in the sections that follow.
- 11 - n** Either 5 bytes of additional status from the “Extended address command-request printer ID” on page 112 command, or up to 246 bytes of user data that can include:
 - MICR data
 - User flash data
 - MCT data

Status byte 1

Bit	Description
0 (LSB)	Command complete (immediate command and flash storage commands). Set to 1 when the command is complete, except for “Erase flash EPROM sector” on page 123, for which it is set to 1 when the command is sent. (See bit 7 of “Status byte 3” on page 185.)
1	Cash receipt right home position. Set to 1 when the print head is in the customer receipt right home position.
2	Left home position Set to 1 when the print head is in the left home position.

Bit	Description
3	Document right home position. Set to 1 when the print head is in the document right home position.
4	Reserved. Always 0.
5	Ribbon cover open. Set to 1 when the ribbon cover is open.
6	Cash receipt print error. Paper cover is open, the customer receipt station is out of paper, or the cutter is jammed in the closed position.
7 (MSB)	Command reject.

Status byte 2

Bit	Description
0 (LSB)	Document ready. Set to 0 when the document insert station is ready for printing. This occurs when both document sensors detect the document and the document has been fed to the first print position.
1	Document present under the front sensor. Set to 0 when a document is under the front document sensor.
2	Document present under the top sensor. Set to 0 when a document is under the top document sensor.
3	Reserved. Always equals 1.
4	Print buffer held. Set to 1 when the print buffer is being held. Cleared when buffer released.
5	Open throat position. Set to 1 when the print head is in the open throat position.
6	Buffer empty. Set to 1 when no print data and no commands are in the buffer.
7 (MSB)	Buffer Full. Set when only 1K bytes are available in the buffer.

Status byte 3

Bit	Description
0 (LSB)	Memory sector is full.
1	Home error.
2	Document error. The document was not inserted after the document station was selected, and the wait subsequently timed out.
3	Flash EPROM load error or MCT load error.
4	Reserved. Always equals 0.
5	User flash storage sector is full.
6	Firmware error. CRC on the firmware failed. The printer is running out of the boot sector. Only system commands and firmware commands are accepted.
7 (MSB)	Command complete ("Erase flash EPROM sector" on page 123, "Flip check" on page 166, and whenever a physical line is printed). Set to 1 when the command is complete or a physical line is printed.

Status byte 4

Contains the printer engineering code (EC) level with all status messages.

Status byte 5

Bit	Description
0 (LSB)	Printer ID Request/Extended Address command. Set to 1 when responding to a Printer ID request.
1	EC Level. Set to 1 when responding to an EC level request.
2	MICR Read. Set to 1 when responding to a MICR read command.
3	MCT Read. Set to 1 when responding to an MCT read command.
4	User flash read. Set to 1 when responding to a flash read command.
5	Reserved. Defaults to 1.
6	Scan Complete. Set to 1 when scan completed successfully.
7 (MSB)	Set to 1 when responding to a "Retrieve scanned image" command.

Status byte 6

Contains the current line count.

Status byte 7

Bit	Description
0 (LSB)	Reserved.
1	Reserved
2	Reserved
3	Cash drawer status (0 if cash drawer status (port pin 3) at ground).
4	Print key pressed (1 = pressed).
5	Reserved. Defaults to 1.
6	Station selected. Set to 1 when document insert station is selected.
7 (MSB)	Document feed error. Set when there is an error after a MICR read command or a flip check command is executed.

Status byte 8

Bit	Description
0 (LSB)	Reserved.
1	Reserved
2	Reserved
3	Reserved
4	Reserved (always 0)
5	Reserved
6	Reserved
7 (MSB)	Thermal print head or motor is almost too hot to continue printing. This bit is set to ON when the printer determines that the print head or motor are getting close to the point where the printer must slow down to keep from overheating the station. This is only supported on Models T18/TG8 and T19/TG9.

Appendix E. Uploading electronic journal data

Enable the upload of EJ data	187
Disable the upload of EJ data	187
Upload the EJ data	188
Request the size of the EJ space	188
Erase the EJ data in the printer	188

This section describes the procedure for uploading electronic journal (EJ) data while the SureMark printer is in Model 4 emulation mode.

Note: Models TI8, TI9, TG8, and TG9 do not support Model 4 emulation.

To put the SureMark into the mode for starting the EJ upload, the SureMark must receive a print command with a unique message. The message will include the line number where the upload should start. Because the starting line number is specified, if the printer is reset during the upload, the application will not have to restart from the beginning. The application can send a command to start at the last line that was sent.

When the EJ upload is enabled, all MICR commands will be interpreted as EJ upload.

The commands that are related to uploading EJ data, which are described in the sections that follow, are:

1. Enable the upload
2. Disable the upload
3. Upload the data
4. Request the size of the EJ space
5. Erase the EJ in the printer

Enable the upload of EJ data

Command Syntax:

X'010100010C'^EJ RQ *n1 n2*

where:

n1 The line number, which is specified as six decimal ASCII numbers.

n2 25 undefined bytes

Example:

X'010100010C'^EJ RQ 00405X'0000000000000000.....' or
X'010100010C5E454A205251203030303430450000000000.....'

Disable the upload of EJ data

Command Syntax:

X'010100010C'^EJ Disable *n1*

where:

n1 27 undefined bytes

Example:

X'010100010C5E454A204449.....'

Upload the EJ data

Command Syntax:`X'0117'`**Remarks:**

In response to this command, the printer will send four status bytes, then 43 bytes of print data, followed by the line number.

The line number will be sent as decimal ASCII numbers.

Request the size of the EJ space

Command Syntax:`X'0101xxxxx'^EJSize n1`**where:**

n1 30 undefined bytes

Example:`X'010100010C5E454A204449.....'`**Remarks:**

When the next MICR read command is sent after this command is sent, the SureMark will send the number of lines that are stored in the printer's memory. It will also send the total number of lines that can be stored in the printer's memory. The printer will then return to normal operation and process MICR commands as MICR commands.

Erase the EJ data in the printer

Command Syntax:`X'0101xxxxx'^EJERase n1`**where:**

n1 30 undefined bytes

Appendix F. Proportional fonts

Preparing the fonts	189
Implementing proportional fonts	189
Layout using align commands	190
Layout using set tab position	191

This section describes the procedure for converting and downloading proportional fonts. It also gives recommendations that will simplify implementing proportional fonts on a receipt.

Preparing the fonts

Downloading proportional fonts to the SureMark is a two-step process:

1. Convert a TrueType font to the SureMark proportional font format. Use the IBM Proportional Fonts Conversion Utility, fontconvert.exe, to convert the fonts. See “Proportional font conversion utility” on page 37.
2. Download the converted font file to the printer.

Implementing proportional fonts

The variable width of proportional fonts can make it difficult to layout a receipt using traditional methods. You can simplify the process of laying out the format of a receipt by using the alignment and tab features of the SureMark printer.

The following topics show how to use the alignment and tab features with proportional fonts. Command descriptions are given in EIA-232 command format. For the command syntax when you use a printer driver, please consult the driver documentation.

A single proportional character set requires two user-defined code pages. Therefore, the printer allows the following combination of user-defined and proportional character sets to be stored in the printer.

Number of Proportional Character Sets	Number of User-Defined Character Sets
0	4
1	2
2	0

Selecting code page 2 when a proportional character set is defined for code page 1 (or selecting code page 4 when proportional characters are defined in code page 3) will result in unreadable characters being printed. See the Select Print Mode command (“Set print mode” on page 129) for more information on selecting code pages.

A proportional character set is enabled using the Select User-Defined Characters command. See “Select user-defined or resident character sets” on page 134.

Layout using align commands

A common requirement for receipt layout includes aligning item prices. This is commonly accomplished using fixed field lengths for item descriptions or counting characters. Using proportional fonts makes this method of alignment practically impossible.

The simplest method to align prices is to use the Align Column Right command (see “Align positions” on page 139) with the Fix Font Matrix command (see “Fix font matrix” on page 146).

- Unlike other Align Position commands, the Align Positions-Align Column Right command can be sent in the middle of a print line. Print characters sent before the alignment command will be left aligned, while characters sent after the alignment command will be right aligned.
- The Fix Font Matrix command forces proportional characters to print using a single width defined by the command. This essentially negates the proportional characteristic of the font, while still allowing the user to utilize the custom font.

The following sequence assumes proportional characters have been downloaded and selected for printing. The following sequence should be used for each item line. The printer output would resemble the following:

```
Candy Bar      $ .45
Fountain Soda  $ 1.11
```

1. Print the item description. For the first item, this is the ASCII data *Candy Bar*.
2. Issue the Set Alignment command with $n=4$ (Right Align Column). The command syntax is X'1B 61 04'.
3. Issue the Fix Font Matrix command with $n=\text{dot width of the widest number used}$. The command syntax is X'1B 3A xx'.

Note: Finding the optimum value of xx for this command will vary depending on the proportional character set being used, and may require some experimentation.

4. Print the item price. For the first item, this is the ASCII data *\$.45*.
5. Issue the Fix Font Matrix command with $n=0$, which disables the fixed font matrix. The command syntax is X'1B 3A 00'.
6. Issue the Print and Line Feed command. Use the command syntax X'0A' or X'0D'.

Layout using set tab position

There are situations where the customer might not want the price right aligned, or requires an additional column (for example, a column for quantity). In such a case, using tabs is the best method to guarantee alignment. Tab positions that you define during the setup operation (see "Set horizontal tab positions" on page 138) will remain intact until the printer is reset or re-initialized. Once tabs are setup, all that is required is to send a tab character X'09' to move to the next tab position. It is still recommended that the Fix Font Matrix be used, if alignment of the individual characters in a field is important (for example, to align the decimal points of prices).

The following Set Tab Positions command will define tab positions for 3 columns: item description, quantity and price. The command assumes that the font width is approximately 10 dots. This procedure assumes that proportional characters have been downloaded and selected for printing, and that the item description will be left aligned.

```
X'1B 44 01 90 01 D6 00 00'
```

The following sequence should be used for each item line. The printer output would resemble the following:

```
Candy Bar    03 $ 1.00  
Fountain Soda 10 $11.10
```

1. Print the item description. For the first item, this is the ASCII data *Candy Bar*.
2. Issue the Tab command. The command syntax is X'09'.
3. Issue the Fix Font Matrix command with n =dot width of the widest number used. The command syntax is X'1B 3A xx'.

Note: Finding the optimum value of xx for this command will vary depending on the proportional character set being used, and may require some experimentation.

4. Print the quantity. For the first item, this is the ASCII data *03*.
5. Issue the Tab command. The command syntax is X'09'.
6. Print the price. For the first item, this is the ASCII data *\$1.00*.
7. Issue the Fix Font Matrix command with $n=0$, which disables the fixed font matrix. The command syntax is X'1B 3A 00'.
8. Issue the Print and Line Feed command. Use the command syntax X'0A' or X'0D'.

Appendix G. Emulation support for Epson single-station printer

Commands supported in emulation mode	193
Commands with limited support in emulation mode	195
Commands not supported in emulation mode	196
Connectivity differences	196
Functional differences	196

The SureMark single-station printers in single-byte character set (SBCS) mode can emulate an Epson single-station printer. Emulation mode provides full support for most Epson commands. However, some commands are supported partially and a few commands are not supported at all. This section describes the commands that have each of the three levels of support and also lists the connectivity differences between an Epson single-station printer and the SureMark.

Note: Ensure that the dip switch on the printer is set to "Other," rather than "IBM."

Commands supported in emulation mode

The commands listed in Table 28 are supported in Epson emulation mode. However, there will be some differences in the printed output, because of different dot pitches in the print heads and the minimum distance that the paper feed motors can move the paper. These differences will appear when there are a number of printed lines, and the method of aligning the data is different.

Examples of the printed differences that might occur:

- Logos will appear smaller in emulation mode. The logo will still contain the same number of dots in the width and height. However, because the SureMark print head has a finer dot pitch, the logo will appear smaller. If text is aligned around the logo, the text on receipts that are printed in emulation mode might not line up the same as receipts that are printed on the Epson printer.
- If one line is aligned using spaces and another line is aligned using the relative position commands, the data might appear misaligned. The commands, such as the relative position and margin commands, that use the minimum unit of motion values are based on a fraction of an inch, which eliminates the differences in the dot pitch. Tabs and spaces are subject to pitch differences.

Table 28. Commands supported in Epson emulation mode

Hex Command	ASCII Command	Description
9	HT	Tab
0A	LF	Line feed
0C	FF	Print and return to standard mode
0D	CR	Print and carriage return
1B 20 n	ESC SP n	Set right-side character spacing
1B 21 n	ESC ! n	Select print mode
1B 24 nL nH	ESC \$ nL nH	Set absolute print position
1B 25 n	ESC % n	Select or cancel user-defined character set
1B 26 y c1 c2...	ESC & y c1 c2...	Define user-defined characters

Table 28. Commands supported in Epson emulation mode (continued)

Hex Command	ASCII Command	Description
1B 2A m nL nH dl..k	ESC * m nL nH dl...k	Select bit-image mode
1B 32	ESC 2	Select default line spacing
1B 33 n	ESC 3 n	Set line spacing
1B 3D n	ESC = n	Set peripheral device
1B 3F n	ESC ? n	Cancel user-defined characters
1B 40	ESC @	Initialize printer
1B 45 n	ESC E n	Turn emphasized mode on or off
1B 47 n	ESC G n	Turn double-strike mode on or off
1B 4A n	ESC J n	Print and feed paper
1B 52 n	ESC R n	Select an international character set
1B 53	ESC S	Select standard mode
1B 56 n	ESC V n	Turn 90° clockwise rotation mode on or off
1B 5C nL nH	ESC \ nL nH	Set relative print position
1B 61 n	ESC a n	Select alignment
1B 63 33 n	ESC c 3 n	Select paper sensor to output paper end signals
1B 63 35 n	ESC c 5 n	Enable or disable panel buttons
1B 64 n	ESC d n	Print and feed n lines
1B 70 m t1 t2	ESC p m t1 t2	Generate pulse
1B 7B n	ESC { n	Turn upside-down printing mode on or off
1C 67 32 m a1 a2 a3 a4...	FS g 2 m a1 a2 a3 a4...	Read from user NV memory
1C 70 n m	FS p n m	Print NV bit image
1D 21 n	GS ! n	Select character size
1D 2A xydl ...d(x*y*8)	GS * xydl ...d(x*y*8)	Define user-defined bit image
1D 2F m	GS / m	Print user-defined bit image
1D 3A	GS :	Start or end user-defined message
1D 42 n	GS B n	Turn white/black reverse printing mode
1D 48 n	GS H n	Select printing position for HRI characters
1D 49 n	GS I n	Transmit printer ID
1D 4C nL nH	GS L nL nH	Set left margin
1D 50 x y	GS P x y	Set horizontal and vertical motion units
1D 56 m n	GS V m n	Select cut mode and cut paper
1D 57 nL nH	GS nL nH	Set printing area width
1D 61 n	GS a n	Enable or disable automatic status back
1D 66 n	GS f n	Select font for HRI characters
1D 68 n	GS h n	Select bar code height
1D 72 n	GS r n	Transmit status

Commands with limited support in emulation mode

The commands listed in Table 29 are supported in a limited manner in Epson emulation mode. The table describes the limitation on each command.

Table 29. Commands with limited support in Epson emulation mode

Command		Description of Limitation
10 04 n	Real-time status transmission	A status byte will be returned when the command is sent. The following status bits will not be supported. <ul style="list-style-type: none"> • Offline status bit 6 • Error status bits 5 and 6 • Paper roll status bits 2 and 3 (near end of paper) - Bit will be set when out of paper
1B 2D n	Turn underline mode on/off	There is no thickness option available. A value of n=1, 2, 49 or 50 will enable underline mode.
1B 44 m1...nk 00	Set horizontal tab positions	The number of tab positions is limited to 5.
1B 63 34 n	Select paper sensor to stop printing	The command will be accepted, but it has no function. There is no paper low sensor on the SureMark. The printer will only return out of paper status.
1B 74 n	Select character code table	All characters on all code pages are not supported. The Katakana code page is not supported.
1D 5E r t m	Execute user-defined message	Does not support the mode where the user-defined message is printed when the paper advance button is pressed.
1D 77 n	Set bar code width	The maximum width is 4 dots on the SureMark. Widths of 5 and 6 will be forced to 4 dots.
1C 67 31 m a1 a2 a3 a4...	Write to user NV memory	If received during user-defined message definition, this command will be embedded in the NV memory. Epson will stop the definition and store the data in NV memory. The user is required to erase the NV memory before the address can be overwritten.
1C 71 n [xL xH yL yH...	Define NV bit image	The width is limited to 576 dots wide and 255 rows high.

Commands not supported in emulation mode

In Epson emulation mode, the SureMark printer supports all Epson commands except the page mode commands and smoothing. Table 30 lists the commands that are not supported.

Table 30. Commands not supported in Epson emulation mode

Hex Command	ASCII Command	Description of Limitation
18	CAN	Cancel print data in page mode
1B 0C	ESC FF	Print data in page mode
1B 4C	ESC L	Select page mode
1B 54 n	ESC T n	Select print direction in page mode
1B 57 xL xH yL yH ...	ESC W xL xH yL yH...	Set printing area in page mode
1D 24 nL nH	GS \$ nL nH	Set absolute vertical print position in page mode
1D 5C nL nH	GS \ nL nH	Set relative vertical print position in page mode
1D 62 n	GS b n	Turn smoothing mode on or off

Connectivity differences

The connectivity differences between an Epson single-station printer and the SureMark printers are:

- The Epson printer offers a parallel interface that the SureMark printer does not support.
- The following EIA-232 modes of communication, which are supported by the Epson single-station printer, are not supported by the SureMark printer:
 - 2400 kbps and 4800 kbps baud
 - 7 bits of data
 - Parity
 - More than one stop bit
 - 25-pin D shell
- To attach the printer to a standard PC serial port:
 - The Epson single-station printer requires a Null Modem cable.
 - The SureMark requires a standard 9-pin D-shell EIA-232 cable.

Functional differences

The following limitations must be considered when using a single-station SureMark printer to emulate an Epson single-station printer:

- When applications switch from Epson printers to IBM printers, there is sometimes a difference in the receipt line spacing. The receipt appears double spaced because, by default, the SureMark printer treats carriage returns (CRs) the same as line feeds (LFs). To change this behavior see “Mode Option” MCT #30 (1E hex) in Table 17 on page 125.
- To provide a more seamless transition between OPOS-driven Epson and IBM printers, IBM now supports an OEM Printer Emulation setting in the OPOS printer device configuration dialog. Enable this setting to produce behavior that is more consistent with that of an Epson printer. (Refer to the Application Programming Guide for your driver.)

Appendix H. Safety information

Danger



Before you begin to install this product, read the safety information in *IBM Safety Information—Read This First*, GA27-4004. This booklet describes safe procedures for cabling and plugging in electrical equipment.

Gevaar



Voordat u begint met de installatie van dit produkt, moet u eerst de veiligheidsinstructies lezen in de brochure *Veiligheidsinstructies—Lees dit eerst*, GA27-4004. Hierin wordt beschreven hoe u elektrische apparatuur op een veilige manier moet bekabelen en aansluiten.

Perigo



Antes de começar a instalar este produto, leia as informações de segurança contidas em *Informações Sobre Segurança—Leia Isto Primeiro*, GA27-4004. Esse folheto descreve procedimentos de segurança para a instalação de cabos e conexões em equipamentos elétricos.

Fare!



Før du installerer dette produkt, skal du læse sikkerhedsforskrifterne i *Sikkerhedsforskrifter—Læs dette først* GA27-4004. Vejledningen beskriver den fremgangsmåde, du skal bruge ved tilslutning af kabler og udstyr.

Gevaar



Voordat u begint met het installeren van dit produkt, dient u eerst de veiligheidsrichtlijnen te lezen die zijn vermeld in de publikatie *IBM Safety Information—Read This First*, GA27-4004. In dit boekje vindt u veilige procedures voor het aansluiten van elektrische apparatuur.

VAARA



Ennen kuin aloitat tämän tuotteen asennuksen, lue julkaisussa *Turvaohjeet—Luetämä ensin*, GA27-4004, olevat turvaohjeet. Tässä kirjasessa on ohjeet siitä, miten sähkölaitteet kaapeloidaan ja kytketään turvallisesti.

Danger

Avant d'installer le présent produit, consultez le livret *Informations pour la sécurité—Lisez-moi d'abord*, GA27-4004, qui décrit les procédures à respecter pour effectuer les opérations de câblage et brancher les équipements électriques en toute sécurité.

Vorsicht

Bevor mit der Installation des Produktes begonnen wird, die Sicherheitshinweise in *Sicherheitsinformationen—Bitte zuerst lesen*, IBM Form GA27-4004. Diese Veröffentlichung beschreibt die Sicherheitsvorkehrungen für das Verkabeln und Anschließen elektrischer Geräte.

Vigyázat

Mielőtt megkezdi a berendezés üzembe helyezését, olvassa el a *IBM Safety Information—Read This First*, GA27-4004 könyvecskében leírt biztonsági információkat. Ez a könyv leírja, milyen biztonsági intézkedéseket kell megtenni az elektromos berendezés huzalozásakor illetve csatlakoztatásakor.

Pericolo

Prima di iniziare l'installazione di questo prodotto, leggere le informazioni relative alla sicurezza riportate nell'opuscolo *Informazioni di sicurezza—Prime informazioni da leggere* in cui sono descritte le procedure per il cablaggio ed il collegamento di apparecchiature elettriche.

Fare

Før du begynner å installere dette produktet, må du lese sikkerhetsinformasjonen i *Sikkerhetsinformasjon—Les dette først*, GA27-4004 som beskriver sikkerhetsrutinene for kabling og tilkobling av elektrisk utstyr.

Perigo

Antes de iniciar a instalação deste produto, leia as informações de segurança *Informações de Segurança—Leia Primeiro*, GA27-4004. Este documento descreve como efectuar, de um modo seguro, as ligações eléctricas dos equipamentos.

Peligro



Antes de empezar a instalar este producto, lea la información de seguridad en *Información de Seguridad—Lea Esto Primero, GA27-4004*. Este documento describe los procedimientos de seguridad para cablear y enchufar equipos eléctricos.

Varning—livsfara



Innan du börjar installera den här produkten bör du läsa säkerhetsinformationen i dokumentet *Säkerhetsföreskrifter—Läs detta först, GA27-4004*. Där beskrivs hur du på ett säkert sätt ansluter elektrisk utrustning.

危險：安裝本產品之前，請先閱讀
"IBM Safety Information--Read
This First" GA27-4004 手冊中所提
供的安全注意事項。這本手冊將會說明
使用電器設備的纜線及電源的安全程序。

Opasnost: Prije nego sto počnete sa instalacijom produkta,
pročitajte naputak o pravilima o sigurnom rukovanju u
Upozorenje: Pravila o sigurnom rukovanju - Prvo pročitaj ovo,
GA27-4004. Ovaj privitak opisuje sigurnosne postupke za
priključivanje kabela i priključivanje na električno napajanje.

Upozornění: než zahájíte instalaci tohoto produktu, přečtěte si
nejprve bezpečnostní informace v pokynech „Bezpečnostní
informace“ č. GA27-4004. Tato brožurka popisuje bezpečnostní
opatření pro kabeláž a zapojení elektrického zařízení.

Κίνδυνος: Πριν ξεκινήσετε την εγκατάσταση αυτού του προϊόντος,
διαβάστε τις πληροφορίες ασφάλειας στο φυλλάδιο *IBM Safety
Information-Read this first, GA27-4004*. Στο φυλλάδιο αυτό
περιγράφονται οι ασφαλείς διαδικασίες για την καλωδίωση των
ηλεκτρικών συσκευών και τη σύνδεσή τους στην πρίζα.

危險：導入作業を開始する前に、安全に関する
小冊子 GA27-4004 の「最初にお読みください」
(Read This First) の項をお読みください。
この小冊子は、電気機器の安全な配線と接続の
手順について説明しています。

위험: 이 제품을 설치하기 전에 반드시
"주의: 안전 정보-시작하기 전에"
(GA27-4004) 에 있는 안전 정보를
읽으십시오.

סכנה: לפני שמתחילים בהתקנת מוצר זה, יש לקרוא את הוראות הבטיחות בחוברת
Caution: Safety Information - Read This First, GA27-4004
חוברת זו מתארת את הוראות הבטיחות לחיבור הכבלים ולחיבור לחשמל של ציוד חשמלי.

خطر: قبل عملية بدء تركيب هذا المنتج، قم بقراءة معلومات
الحمية الموجودة في التحذير: معلومات الحماية - Read This First
GA27-4004 . يقوم هذا الكتيب بوصف اجراءات الأمان
لتوصيل الأدوات الكهربائية بالكابلات والمقبس الكهربائي.

ОПАСНОСТ

Пред да почнете да го инсталирате овој продукт, прочитајте ја информацијата за безбедност:
"Предупредување: Информација за безбедност: Прочитајте го прво ова", GA27-4004.
Оваа брошура опишува безбедносни процедури за каблирање и вклучување на електрична опрема.

Uwaga:

Przed rozpoczęciem instalacji produktu należy zapoznać się z instrukcją: "IBM Safety Information - Read This First", GA27-4004.
Zawiera ona warunki bezpieczeństwa przy podłączaniu do sieci elektrycznej i eksploatacji.

ОСТОРОЖНО: Прежде чем устанавливать этот продукт, прочтите Инструкцию по технике безопасности в документе "Внимание: Инструкция по технике безопасности -- Прочестъ в первую очередь", GA27-4004. В этой брошюре описаны безопасные способы каблирования и подключения электрического оборудования.

Nebezpečenstvo: Pred inštaláciou výrobku si prečítajte bezpečnosté predpisy v
Výstraha: Bezpečnosté predpisy - Prečítaj ako prvé, GA27-4004. V tejto brožúrke sú opísané bezpečnosté postupy pre pripojenie elektrických zariadení.

Pozor: Preden začnete z instalacijo tega produkta preberite poglavje: "Opozorilo: Informacije o varnem rokovanju-preberi pred uporabo," GA27-4004. To poglavje opisuje pravilne postopke za kabliranje,

危險：

開始安裝此產品之前，請先閱讀安全資訊。

注意：

請先閱讀 - 安全資訊 GA27-4004

此冊子說明插接電器設備之電纜線的安全程序。

危險：

在開始安裝本產品之前，請閱讀

IBM Safety Information - Read This First,
GA27-4004 中的安全信息。

此手冊描述了如何安全地連接和插拔電氣設備。

Appendix I. Notices

This information was developed for products and services offered in the U.S.A.

IBM may not offer the products, services, or features discussed in this document in other countries. Consult your local IBM representative for information on the products and services currently available in your area. Any reference to an IBM product, program, or service is not intended to state or imply that only that IBM product, program, or service may be used. Any functionally equivalent product, program, or service that does not infringe any IBM intellectual property right may be used instead. However, it is the user's responsibility to evaluate and verify the operation of any non-IBM product, program, or service.

IBM may have patents or pending patent applications covering the subject matter in this document. The furnishing of this document does not give you any license to these patents. You can send license inquiries, in writing, to:

IBM Director of Licensing
IBM Corporation
North Castle Drive
Armonk, NY 10504-1785
U.S.A.

For license inquiries regarding double-byte character set (DBCS) information, contact the IBM Intellectual Property Department in your country or send inquiries, in writing, to:

IBM World Trade Asia Corporation
Licensing
2-31 Roppongi 3-chome, Minato-ku
Tokyo 106, Japan

The following paragraph does not apply to the United Kingdom or any other country where such provisions are inconsistent with local law: INTERNATIONAL BUSINESS MACHINES CORPORATION PROVIDES THIS PUBLICATION "AS IS" WITHOUT WARRANTY OF ANY KIND, EITHER EXPRESS OR IMPLIED, INCLUDING, BUT NOT LIMITED TO, THE IMPLIED WARRANTIES OF NON-INFRINGEMENT, MERCHANTABILITY, OR FITNESS FOR A PARTICULAR PURPOSE. Some states do not allow disclaimer of express or implied warranties in certain transactions, therefore, this statement may not apply to you.

This information could include technical inaccuracies or typographical errors. Changes are periodically made to the information herein; these changes will be incorporated in new editions of the publication. IBM may make improvements and/or changes in the product(s) and/or program(s) described in this publication at any time without notice.

IBM may use or distribute any of the information you supply in any way it believes appropriate without incurring any obligation to you.

Any references in this information to non-IBM Web sites are provided for convenience only and do not in any manner serve as an endorsement of those Web sites. The materials at those Web sites are not part of the materials for this IBM product and use of those Web sites is at your own risk.

Information concerning non-IBM products was obtained from the suppliers of those products, their published announcements or other publicly available sources. IBM has not tested those products and cannot confirm the accuracy of performance, compatibility or any other claims related to non-IBM products. Questions on the capabilities of non-IBM products should be addressed to the suppliers of those products.

This information is for planning purposes only. The information herein is subject to change before the products described become available.

Electronic emission notices

Federal Communications Commission (FCC) statement

This equipment has been tested and found to comply with the limits for a Class A digital device, pursuant to Part 15 of the FCC Rules. These limits are designed to provide reasonable protection against harmful interference when the equipment is operated in a commercial environment. This equipment generates, uses, and can radiate radio frequency energy and, if not installed and used in accordance with the instruction manual, may cause harmful interference to radio communications. Operation of this equipment in a residential area is likely to cause harmful interference, in which case the user will be required to correct the interference at his own expense.

Properly shielded and grounded cables and connectors must be used in order to meet FCC emission limits. IBM is not responsible for any radio or television interference caused by using other than recommended cables and connectors or by unauthorized changes or modifications to this equipment. Unauthorized changes or modifications could void the user's authority to operate the equipment.

This device complies with part 15 of the FCC Rules. Operation is subject to the following two conditions:

1. This device may not cause harmful interference, and
2. This device must accept any interference received, including interference that may cause undesired operation.

European Union EMC Directive conformance statement

This product is in conformity with the protection requirements of EU Council Directive 2004/108/EC on the approximation of the laws of the Member States relating to electromagnetic compatibility. IBM cannot accept responsibility for any failure to satisfy the protection requirements resulting from a non-recommended modification of the product, including the fitting of non-IBM option cards.

This product has been tested and found to comply with the limits for Class A Information Technology Equipment according to CISPR 22/European Standard EN 55022. The limits for Class A equipment were derived for commercial and industrial environments to provide reasonable protection against interference with licensed communication equipment.

Attention: This is a Class A product. In a domestic environment this product may cause radio interference in which case the user may be required to take adequate measures.

European Community contact:

IBM Technical Regulations
Pascalstr. 100, Stuttgart, Germany 70569
Telephone: 0049 (0)711 785 1176
Fax: 0049 785 1283
E-mail: tjahn@de.ibm.com

Industry Canada Class A Emission Compliance statement

This Class A digital apparatus complies with Canadian ICES-003.

Avis de conformité aux normes d'Industrie Canada

Cet appareil numérique de la classe A est conforme à la norme NMB-003 du Canada.

Germany

Zulassungsbescheinigung laut dem Deutschen Gesetz über die elektromagnetische Verträglichkeit von Geräten (EMVG) vom 30. August 1995 (bzw. der EMC EG Richtlinie 89/336).

Dieses Gerät ist berechtigt in Übereinstimmung mit dem Deutschen EMVG das EG-Konformitätszeichen - CE - zu führen.

Verantwortlich für die Konformitätserklärung nach Paragraph 5 des EMVG ist die IBM Deutschland Informationssysteme GmbH, 70548 Stuttgart

Informationen in Hinsicht EMVG Paragraph 3 Abs. (2) 2:

Das Gerät erfüllt die Schutzanforderungen nach EN 50082-1 und EN 55022 Klasse A.
--

EN 55022 Klasse A Geräte müssen mit folgendem Warnhinweis versehen werden:

"Warnung: dies ist eine Einrichtung der Klasse A. Diese Einrichtung kann im Wohnbereich Funkstörungen verursachen; in diesem Fall kann vom Betreiber verlangt werden, angemessene Maßnahmen durchzuführen und dafür aufzukommen."

EN 50082-1 Hinweis:

"Wird dieses Gerät in einer industriellen Umgebung betrieben (wie in EN 50082-2 festgelegt), dann kann es dabei eventuell gestört werden. In solch einem Fall ist der Abstand bzw. die Abschirmung zu der industriellen Störquelle zu vergrößern."

Anmerkung:

Um die Einhaltung des EMVG sicherzustellen sind die Geräte, wie in den IBM Handbüchern angegeben, zu installieren und zu betreiben.

Australia and New Zealand

Attention: This is a Class A product. In a domestic environment this product may cause radio interference, in which case the user may be required to take adequate measures.

Chinese Class A warning statement

Attention: This is a Class A product. In a domestic environment this product may cause radio interference in which case the user may be required to take adequate measures.

中华人民共和国“A类”警告声明

声 明

此为 A 级产品，在生活环境中，该产品可能会造成无线电干扰。在这种情况下，可能需要用户对其干扰采取切实可行的措施。

Japanese power line harmonics compliance statement

高調波ガイドライン適合品

高調波ガイドライン適合品

Japanese Voluntary Control Council for Interference (VCCI) statement

Attention: This product is a Class A Information Technology Equipment and conforms to the standards set by the Voluntary Control Council for Interference by Technology Equipment (VCCI). In a domestic environment this product may cause radio interference in which case the user may be required to take adequate measures.

この装置は、情報処理装置等電波障害自主規制協議会（VCCI）の基準に基づくクラスA情報技術装置です。この装置を家庭環境で使用すると電波妨害を引き起こすことがあります。この場合には使用者が適切な対策を講ずるよう要求されることがあります。

Korean communications statement

Please note that this device has been approved for business purposes with regard to electromagnetic interference. If you find this is not suitable for your use, you may exchange it for a non-business purpose one.

A급 기기(업무용)

이 기기는 업무용으로 전자파적합등록을 받은 기기이오니 판매자 또는 이용자는 이점을 주의하시기 바라며, 만약 구입하였을 때에는 구입한 곳에서 가정용으로 교환하시기 바랍니다.

Taiwanese Class A warning statement

警告使用者：
這是甲類的資訊產品，在
居住的環境中使用時，可
能會造成射頻干擾，在這
種情況下，使用者會被要
求採取某些適當的對策。

Taiwan contact information

台灣IBM 產品服務聯絡方式：
台灣國際商業機器股份有限公司
台北市松仁路7號3樓
電話：0800-016-888

IBM Taiwan Product Service Contact Info:
IBM Taiwan Corporation
3F, No 7, Song Ren Road, Taipei Taiwan
Telephone: 0800-016-888

Cable ferrite requirement

All cable ferrites are required to suppress radiated EMI emissions and must not be removed.

Electrostatic Discharge (ESD)

Attention: ESD damage can occur when there is a difference in charge between the part, the product, and the service person. No damage will occur if the service person and the part being installed are at the same charge level.

ESD Damage Prevention

Anytime a service action involves physical contact with logic cards, modules, back-panel pins, or other ESD sensitive (ESDS) parts, the service person must be connected to an ESD common ground point on the product through the ESD wrist strap and cord.

The ESD ground clip can be attached to any frame ground, ground braid, green wire ground, or the round ground prong on the AC power plug. Coax or connector outside shells can also be used.

Handling Removed Cards

Logic cards removed from a product should be placed in ESD protective containers. No other object should be allowed inside the ESD container with the logic card. Attach tags or reports that must accompany the card to the outside of the container.

Product Recycling and disposal

This unit must be recycled or discarded according to applicable local and national regulations. IBM encourages owners of information technology (IT) equipment to responsibly recycle their equipment when it is no longer needed. IBM offers a variety of product return programs and services in several countries to assist equipment owners in recycling their IT products. Information on IBM product recycling offerings can be found on IBM's Internet site at <http://www.ibm.com/ibm/environment/products/prp.shtml>.

Español:

Esta unidad debe reciclarse o desecharse de acuerdo con lo establecido en la normativa nacional o local aplicable. IBM recomienda a los propietarios de equipos de tecnología de la información (TI) que reciclen responsablemente sus equipos cuando éstos ya no les sean útiles. IBM dispone de una serie de programas y servicios de devolución de productos en varios países, a fin de ayudar a los propietarios de equipos a reciclar sus productos de TI. Se puede encontrar información sobre las ofertas de reciclado de productos de IBM en el sitio web de IBM <http://www.ibm.com/ibm/environment/products/prp.shtml>.



Notice: This mark applies only to countries within the European Union (EU) and Norway.

Appliances are labeled in accordance with European Directive 2002/96/EC concerning waste electrical and electronic equipment (WEEE). The Directive determines the framework for the return and recycling of used appliances as applicable throughout the European Union. This label is applied to various products to indicate that the product is not to be thrown away, but rather reclaimed upon end of life per this Directive.

Remarque : Cette marque s'applique uniquement aux pays de l'Union Européenne et à la Norvège. L'étiquette du système respecte la Directive européenne 2002/96/EC en matière de Déchets des Equipements Electriques et Electroniques

(DEEE), qui détermine les dispositions de retour et de recyclage applicables aux systèmes utilisés à travers l'Union européenne. Conformément à la directive, ladite étiquette précise que le produit sur lequel elle est apposée ne doit pas être jeté mais être récupéré en fin de vie.

注意: このマークは EU 諸国およびノルウェーにおいてのみ適用されます。

この機器には、EU 諸国に対する廃電気電子機器指令 2002/96/EC(WEEE) のラベルが貼られています。この指令は、EU 諸国に適用する使用済み機器の回収とリサイクルの骨子を定めています。このラベルは、使用済みになった時に指令に従って適正な処理をする必要があることを知らせるために種々の製品に貼られています。

In accordance with the European WEEE Directive, electrical and electronic equipment (EEE) is to be collected separately and to be reused, recycled, or recovered at end of life. Users of EEE with the WEEE marking per Annex IV of the WEEE Directive, as shown above, must not dispose of end of life EEE as unsorted municipal waste, but use the collection framework available to customers for the return, recycling, and recovery of WEEE. Customer participation is important to minimize any potential effects of EEE on the environment and human health due to the potential presence of hazardous substances in EEE. For proper collection and treatment, contact your local IBM representative.

Disposal of IT products should be in accordance with local ordinances and regulations.

Battery return program

This product may contain sealed lead acid, nickel cadmium, nickel metal hydride, lithium, or lithium ion battery. Consult your user manual or service manual for specific battery information. The battery must be recycled or disposed of properly. Recycling facilities may not be available in your area. For information on disposal of batteries outside the United States, go to <http://www.ibm.com/ibm/environment/products/batteryrecycle.shtml> or contact your local waste disposal facility.

In the United States, IBM has established a return process for reuse, recycling, or proper disposal of used IBM sealed lead acid, nickel cadmium, nickel metal hydride, and other battery packs from IBM equipment. For information on proper disposal of these batteries, contact IBM at 1-800-426-4333. Please have the IBM part number listed on the battery available prior to your call.

For Taiwan:



Please recycle batteries.

For the European Union:



Notice: This mark applies only to countries within the European Union (EU)

Batteries or packaging for batteries are labeled in accordance with European Directive 2006/66/EC concerning batteries and accumulators and waste batteries and accumulators. The Directive determines the framework for the return and recycling of used batteries and accumulators as applicable throughout the European Union. This label is applied to various batteries to indicate that the battery is not to be thrown away, but rather reclaimed upon end of life per this Directive.

Les batteries ou emballages pour batteries sont étiquetés conformément aux directives européennes 2006/66/EC, norme relative aux batteries et accumulateurs en usage et aux batteries et accumulateurs usés. Les directives déterminent la marche à suivre en vigueur dans l'Union Européenne pour le retour et le recyclage des batteries et accumulateurs usés. Cette étiquette est appliquée sur diverses batteries pour indiquer que la batterie ne doit pas être mise au rebut mais plutôt récupérée en fin de cycle de vie selon cette norme.

バッテリーあるいはバッテリー用のパッケージには、EU 諸国に対する廃電気電子機器指令 2006/66/EC のラベルが貼られています。この指令は、バッテリーと蓄電池、および廃棄バッテリーと蓄電池に関するものです。この指令は、使用済みバッテリーと蓄電池の回収とリサイクルの骨子を定めているもので、EU 諸国にわたって適用されます。このラベルは、使用済みになったときに指令に従って適正な処理をする必要があることを知らせるために種々のバッテリーに貼られています。

In accordance with the European Directive 2006/66/EC, batteries and accumulators are labeled to indicate that they are to be collected separately and recycled at end of life. The label on the battery may also include a chemical symbol for the metal concerned in the battery (Pb for lead, Hg for mercury and Cd for cadmium). Users of batteries and accumulators must not dispose of batteries and accumulators as unsorted municipal waste, but use the collection framework available to customers for the return, recycling and treatment of batteries and accumulators. Customer participation is important to minimize any potential effects of batteries and accumulators on the environment and human health due to the potential presence of hazardous substances. For proper collection and treatment, contact your local IBM representative.

This notice is provided in accordance with Royal Decree 106/2008 of Spain: The retail price of batteries, accumulators and power cells includes the cost of the environmental management of their waste.

For California:

Perchlorate material – special handling may apply

Refer to <http://www.dtsc.ca.gov/hazardouswaste/perchlorate>.

The foregoing notice is provided in accordance with *California Code of Regulations Title 22, Division 4.5, Chapter 33: Best Management Practices for Perchlorate Materials*. This product/part includes a lithium manganese dioxide battery which contains a perchlorate substance.

Flat panel displays

The fluorescent lamp in the liquid crystal display contains mercury. Dispose of it as required by local ordinances and regulations.

Monitors and workstations

Connecticut - Please see the web site of the Department of Environmental Protection at <http://www.ct.gov/dep> for information about recycling covered electronic devices in the State of Connecticut, or telephone the Connecticut Department of Environmental Protection at 1-860-424-3000.

Oregon - For information regarding recycling covered electronic devices in the state of Oregon, go to the Oregon Department of Environmental Quality site at <http://www.deq.state.or.us/lq/electronics.htm>.

Washington - For information about recycling covered electronic devices in the State of Washington, go to the Department of Ecology Web site at <https://fortress.wa.gov/ecy/recycle/> or telephone the Washington Department of Ecology at 1-800Recycle.

Trademarks

The following are trademarks of International Business Machines Corporation in the United States or other countries, or both:

AnyPlace Kiosk(tm)
AnyPlace POS Hub(tm)
DB2
DB2 Universal Database
IBM and the IBM logo
PS/2
SureMark
SurePoint
SurePOS
Wake on LAN
WebSphere

Microsoft, Windows, Windows NT, and the Windows logo are trademarks of Microsoft Corporation in the United States, other countries, or both.

Celeron and Intel are trademarks of Intel corporation in the United States, or other countries.

Java and all Java-based trademarks and logos are trademarks or registered trademarks of Sun Microsystems, Inc. in the United States, or other countries, or both.

Other company, product, or service names may be trademarks or service marks of others.

Index

Numerics

- 4610 fonts and logos 37
- 4610 fonts and logos utilities 37

A

- AipFlsh46 40
- align positions command 139
- application requirements 14
- asynchronous commands 175

B

- bar code commands
 - enable PDF417 truncation 155
 - print bar code 147
 - print PDF417 bar code 153
 - select aspect ratio PDF417 bar code 155
 - select bar code height 152
 - select font for HRI 153
 - select horizontal size of bar code 152
 - select PDF417 ECC level 154
 - select printing position of HRI 152
- bar codes, supported 15
- batch printing commands 176
- battery return program 210
- battery, European Union 210
- baud rate selection, EIA-232 28
- baud rate selection, EIA-232, Model T18 30
- BMP 5

C

- cable ferrite requirement 208
- calibration, document scanner 60
- cash drawer drive pulse command 161
- cash drawer pin assignments 90
- character fonts 98
- check processing commands 164
- check verification, printing 47
- checks, clearing jams 55
- Class A compliance statement
 - Australia and New Zealand 206
 - China 207
 - European Union 205
 - FCC (USA) 205
 - Germany 206
 - Industry Canada 206
 - Japan 207
 - Taiwan 208
- cleaning
 - MICR reader read head 56
 - scanner 59
 - thermal print head (Model T11, T12, T13, T14, T18, TG3, TG4) 57
 - thermal print head (Models TF6 and TM6) 73
- clearing jams, DI station 55

- code page command, set 135
- code pages
 - code page 437 94
 - code page 858 95
 - code page 860 96
 - code page 863 97
 - code page 865 98
 - definitions 92
 - generic 93
 - resident 15
- code pages, resident 15
- command line utility 40
- commands, EIA-232
 - asynchronous 175
 - bar code commands 147
 - batch printing 176
 - check processing 164
 - data buffer management 176
 - document handling 181
 - document scanner 166
 - miscellaneous 160
 - page mode printing 177
 - preset 114
 - print character 156
 - print graphics (logo) command 157
 - setup 129
 - system 111
- commands, immediate 89
- communication interfaces 10
- communication mode selection
 - EIA-232 28, 30
 - USB 31
- consumable supplies 81
- controls, printer
 - Models TF6 and TM6 71
 - Models T11, T12, T13, T14, T18, T19, TG3, TG4, TG8, TG9 47
- conversion utility, proportional fonts 37

D

- damage from electrostatic discharge 208
- data buffer management commands 176
- define document wait time command 141
- dimensions, physical 10
- disable feed buttons 143
- disable line count 176
- disable the beeper 143
- disable upside-down printing 144
- diskette, fonts and logos utilities, 4610 37
- diskettes
 - related xvi
- disposal of equipment 209
- document format 5
- document handling
 - landscape mode 182
 - portrait mode 181
- document handling, landscape mode commands 182

document handling, portrait mode commands 181
 document insert forms 82
 document length, setting 133
 document scanner calibration 60
 double-high mode command, set or cancel 131
 double-wide mode command, set or cancel 130
 download graphics (logo) commands 115
 download user-defined characters command 118
 DTR and DSR
 control description 29, 30
 selection 28

E

EC request command 175
 edition notice ii
 EIA-232 commands 101
 1/6-in. line spacing, select 136
 1/8-in. line spacing, select 136
 align positions 139
 asynchronous 175
 bar code commands 147
 enable PDF417 truncation 155
 print bar code 147
 print font, select HRI 153
 print PDF417 bar code 153
 print position, select HRI 152
 select aspect ratio PDF417 bar code 155
 select PDF417 ECC level 154
 set bar code height 152
 set bar code horizontal size 152
 batch printing 176
 cash drawer drive pulse 161
 character for reprinted line, select 142
 check processing 164
 data buffer management 176
 define document wait time 141
 disable line count 176
 document handling 181
 document scanner 166
 download graphics (logo) 115
 download user-defined characters 118
 EC request 175
 EIA-232 parameters 91
 emphasized printing, set or cancel 132
 enable/disable the beeper 143
 enable/disable upside-down printing 144
 erase flash EPROM sector 123
 exercise program 111
 extended address command 112
 feed buttons 143
 feed minimum units 156
 feed n lines 156
 fix font matrix 146
 flash storage write 123
 flip check 166
 form feed and cut 156
 hold printing 177
 impact code page 122
 landscape printing 183
 line feed, print 156
 EIA-232 commands (*continued*)
 line spacing, minimum units 137
 maximum print speed 132
 MICR read 165
 microcode tolerance, loading 124
 microcode tolerance, request 125
 miscellaneous 160
 onetime-set 114
 page mode printing 177
 paper cut/DI eject 161
 predefine messages 117
 preset 114
 print and line feed 156
 print character 156
 print graphics (logo) command 157
 print head home position, select 160
 print logo inline 146
 print mode, set 129
 print predefined logo 159
 print predefined messages 159
 proportional font 120
 real-time 175
 real-time status request 175
 release print buffer 175
 Request document length 133
 reset line count 176
 retrieve flash storage 161
 retrieve printer usage statistics 162
 retrieve size of flash storage 162
 reverse print and feed paper 157
 select character sets 134
 select character size for scalable fonts 145
 select color printing 137
 select thermal paper 147
 send checksum flash EPROM sector 124
 send status to system 141
 set code page 135
 Set document length for landscape print 133
 set error recovery 140
 set horizontal tabs 138
 set intercharacter spacing 135
 set left margin 138
 set or cancel double-high mode 131
 set or cancel double-wide mode 130
 set or cancel invert 131
 set or cancel overline mode 131
 set or cancel rotated characters 135
 set or cancel underline mode 131
 set print station 134
 set print station parameters 136
 set relative position 139
 set sheet eject length 138
 setup 129
 status bytes 184, 186
 status request 112
 status summary 184
 system 111
 tab to next tab stop 160
 thermal code page 119
 unidirectional printing, set or cancel 133
 verify previous commands completed 111

- EIA-232 communication mode selections 28, 30
- EIA-232 pin assignments 91
- electronic emissions notices 205
 - Australia and New Zealand 206
 - China 207
 - European Union 205
 - FCC (USA) 205
 - Germany 206
 - Industry Canada 206
 - Japan 207
 - Korea 207
 - Taiwan 208
- electronic journal data, upload during emulation 187
- electrostatic discharge (ESD) 208
- emphasized printing command, set or cancel 132
- emptying printer buffer 41
- emulate Epson single-station printer
 - commands with limited support 195
 - connectivity differences 196
 - enabling 43
 - fully-supported commands 193
 - limitations 43
 - overview 43
 - unsupported commands 196
- emulate Model 3 or 4 printer
 - limitations 41
 - overview 41
 - upload electronic journal data 187
- emulation, Epson 193
- enable feed buttons 143
- enable the beeper 143
- enable upside-down printing 144
- end of life disposal 209
- Epson emulation 193
- equipment disposal 209
- erase flash EPROM sector command 123
- error recovery command, set 140
- exercise program 111
- expendable supplies 83
- extended address command 112

F

- features, all models 6
- ferrite requirement 208
- fillers, installing
 - for EIA-232/RS-485 printers 24
 - for USB printers 26
- firmware update image 39
- firmware update, printer 39
- firmware, updating
 - firmware update diskette 38
 - limitation 41
 - methods 37
 - POSS for Windows 39
 - via EIA-232 attachment 40
- fix font matrix 146
- flash memory
 - printing 41
 - usage 89

- flash storage
 - retrieve 161
 - retrieve size 162
- flash storage write command 123
- flat panel displays 212
- flip check command 166
- flippable document specifications 82
- fonts
 - character 98
 - impact printing 99
 - thermal printing 98
- fonts and logos utilities, 4610 37
- fonts and logos, 4610 37
- fonts, character 98
- fonts, proportional 189
- forms, document insert, specifications 82

G

- general description 87
- generic code page 93

H

- hardware requirements 13
- height, all models 10
- hex dump, EIA-232 66, 77
- hold printing command 177
- horizontal tabs command, set 138
- humidity requirements 10

I

- IBM Diagnostics for POS Systems and Peripherals 41
- IBM Retail Store Solutions Web site 44
- immediate commands 89
- impact code page command 122
- indicators, printer
 - Models TF6 and TM6 71
 - Models TI1, TI2, TI3, TI4, TI8, TI9, TG3, TG4, TG8, TG9 47
- information, planning 9
- installation, single-station
 - power-on self-test, TF6 and TM6 75
 - problem determination, Models TF6 and TM6 78
 - testing, Models TF6 and TM6 75
- installation, thermal/impact
 - fillers for EIA-232/RS-485 printers 24
 - fillers for USB printers 26
 - for EIA-232/RS-485 communication 18
 - for USB communication 21
 - power-on self-test, Models TI1/TI2/TI3/TI4/TI8 61
 - preparation 17
 - problem determination, Models TI1/TI2/TI3/TI4/TI8/TI9/TG3/TG4/TG8/TG9 67
 - testing, Models TI1/TI2/TI3/TI4 61
 - unpacking 18
- intercharacter spacing command, set 135
- interfaces, communication 10
- introduction 3
- invert command, set or cancel 131

J

Japanese power line harmonics compliance statement 207
 Japanese Voluntary Control Council for Interference statement 207
 JavaPOS for Windows 39
 JPEG 5

K

Korean communications statement 207

L

landscape printing commands 183
 left margin command, set 138
 limitations 9
 line spacing, minimum units 137
 line spacing, select 1/6 136
 line spacing, select 1/8 136

M

maintenance, printers 85
 maintenance, service provider 85
 memory units 89
 mercury-added statement 212
 MICR data parser sample code 44
 MICR read
 read command 165
 MICR reader and check flipper test 65
 MICR reader read head cleaning 56
 microcode tolerance (MCT)
 loading command 124
 request command 125
 miscellaneous EIA-232 commands 160
 Model 3 or 4 printer, emulate
 limitations 41
 overview 41
 model comparison 7
 multipart form specifications 82

N

notices 203
 battery recycling 210
 cable ferrites 208
 electronic emissions 205
 electrostatic discharge (ESD) 208
 end of life disposal 209
 IBM 203
 safety information 197

O

offline test, single-station printer
 customer receipt 76
 reset printer 78
 test pattern 77

offline test, thermal/impact printer
 customer receipt test 62
 document insert test 63
 MICR reader and check flipper test 65
 onetime-set commands 114
 operating system requirements 13
 overline mode command, set or cancel 131
 overview 3

P

paper cut/DI eject command 161
 paper width 87
 paper, document insert, specifications 82
 paper, select thermal 147
 paper, thermal, specifications 81
 parameters, serial RS-485 90
 perchlorate 211
 physical dimensions 10
 pin assignments
 cash drawer connector 90
 EIA-232 connector 91
 USB connector 92
 planning information 9
 power requirements 12
 predefine messages command 117
 preset commands 114
 print and line feed command 156
 print character commands 156
 print head cleaning, thermal
 Models TF6 and TM6 73
 Models TI1, TI2, TI3, TI4, TI8, TG3, TG4 57
 print head cleaning, thermal head 57
 print logo inline 146
 print mode command, set 129
 print predefined graphics (logo) command 159
 print scanned image command 168
 print station command, set 134
 print station parameters command, set 136
 print width 87
 printed copy of scanned check 66
 printer firmware update using JavaPOS 39
 printer, single-station
 indicators and controls 71
 operation 71
 paper loading 71
 printer, thermal/impact
 check verification 47
 clearing jams, DI station 55
 indicators and controls 47
 installing EIA-232/RS-485 fillers 24
 installing for EIA-232/RS-485 18
 installing for USB 21
 installing USB fillers 26
 operation 47
 paper loading 53
 ribbon loading 51
 ribbon specifications 83
 printing flash memory 41
 printing saved data 41

- problem determination, single-station printer
 - customer receipt test 76
 - symptoms 78
- problem determination, thermal/impact printer
 - customer receipt test 62
 - symptoms 67
- product care 85
- programming information 101
- proportional font command 120
- proportional fonts 189
 - conversion utility 37
 - implementing 189
 - layout using alignment 190
 - layout using tabs 191
- publications
 - CD-ROM book collection xvi
 - Web site xvi
- publications, related xvi

R

- RAM
 - usage 89
- re-initialize the printer command 142
- real-time commands 175
- real-time status request command 175
- related publications and diskettes xvi
- relative position command, set 139
- release print buffer command 175
- Request document length 133
- request printer ID command 112
- requirements
 - application programs 14
 - hardware 13
 - humidity 10
 - operating system 13
 - power 12
 - software 13
 - temperature 10
- reset line count 176
- reset printer 175
- resetting the printer
 - Models TF6 and TM6 78
 - Models TI1, TI2, TI3, TI4, TI8, TG3, TG4 66
- resident code pages 15
- retrieve first unread image location command 174
- retrieve flash storage command 161
- retrieve next image location command 174
- retrieve printer usage statistics command 162
- retrieve scanned image command 172
- retrieve size of flash storage command 162
- reverse print and feed paper 157
- ribbon loading 51
- ribbons, print 83
- rotated characters command, set or cancel 135
- RS-485
 - parameters, serial 90

S

- safety information 197
- saved data, printing 41
- scanned check printout 66
- scanned document format 5
- scanner
 - cleaning 59
- scanner calibration 60
- scanner calibration command 173
- scanner commands
 - print scanned image 168
 - retrieve first unread image location 174
 - retrieve next image location 174
 - retrieve scanned image 172
 - scanner calibration 173
 - select compression format and scanned image threshold 174
 - start scan 166
 - store scanned image 169
- scanner resolution 173
- select
 - 1/6-in. line spacing, select 136
 - 1/8-in. line spacing command 136
 - character for reprinted line command 142
 - character sets command 134
 - HRI (bar code) font 153
 - HRI (bar code) position 152
 - print graphics (logo) command 157
 - print head home position command 160
- select character size for scalable fonts 145
- select color printing command 137
- select compression format and scanned image threshold command 174
- select maximum print speed 132
- send checksum flash EPROM sector command 124
- send status to system command 141
- service proficer, system maintenance 85
- Set document length for landscape print 133
- set horizontal tabs command 138
- setup
 - commands 129
 - set or cancel high quality print mode 132
- sheet eject length command, set 138
- single form specifications 82
- software adjustments
 - updating firmware 37
 - using reference/service diskette 35
- software requirements 13
- specifications
 - cash drawer pins 90
 - document insert forms 82
 - documents to be flipped 82
 - EIA-232 pins 91
 - fonts 98
 - forms, single and multipart 82
 - memory 89
 - paper width 87
 - pitch 87
 - print ribbons 83
 - print width 87
 - RS-485 serial I/O 90

specifications (*continued*)
 speed 87
 thermal paper 81
 USB pins 92
 speed, print 87
 start scan command 166
 status
 request 111, 112
 summary 184
 status bytes, EIA-232 184
 status request command 112
 store scanned image command 169
 supplies 83
 supplies, where to order 81

T

tab to next tab stop command 160
 Taiwanese battery recycling statement 210
 temperature requirements 10
 testing
 Models TF6 and TM6 75
 Models TI1/TI2/TI3/TI4/TI8 61
 thermal code page command 119
 thermal paper specifications 81
 thermal paper, select 147
 TIFF 5
 trademarks 212
 TrueType fonts conversion utility 37

U

underline mode command, set or cancel 131
 unidirectional printing command, set or cancel 133
 unpacking the printer 18
 update firmware
 firmware update diskette 38
 limitation 41
 methods 37
 POSS for Windows 39
 via EIA-232 attachment 40
 upload electronic journal data during emulation 187
 USB communication mode 31
 USB pin assignments 92

V

verify previous commands completed 111
 voltage conversion circuitry 89

W

wall mounting feature, single-station printers 23
 warranty information, all models 5
 Web site, IBM Retail Store Solutions 44
 weight, all models 10
 where to order supplies 81

X

XON and XOFF
 control description 29, 30
 selection 28

Readers' Comments — We'd Like to Hear from You

**SureMark 4610 Printers
User's Guide for
Models T11, T12, T13, T14, T18, T19, TG3, TG4, TG8, TG9, TF6, and TM6**

Publication No. GA27-4151-07

We appreciate your comments about this publication. Please comment on specific errors or omissions, accuracy, organization, subject matter, or completeness of this book. The comments you send should pertain to only the information in this manual or product and the way in which the information is presented.

For technical questions and information about products and prices, please contact your IBM branch office, your IBM business partner, or your authorized remarketer.

When you send comments to IBM, you grant IBM a nonexclusive right to use or distribute your comments in any way it believes appropriate without incurring any obligation to you. IBM or any other organizations will only use the personal information that you supply to contact you about the issues that you state on this form.

Comments:

Thank you for your support.

Send your comments to the address on the reverse side of this form.

If you would like a response from IBM, please fill in the following information:

Name

Address

Company or Organization

Phone No.

E-mail address



Fold and Tape

Please do not staple

Fold and Tape



NO POSTAGE
NECESSARY
IF MAILED IN THE
UNITED STATES

BUSINESS REPLY MAIL

FIRST-CLASS MAIL PERMIT NO. 40 ARMONK, NEW YORK

POSTAGE WILL BE PAID BY ADDRESSEE

IBM Corporation
Dept ZBDA/Bldg. 307
P. O. Box 12195
Research Triangle Park, NC 27709-9990

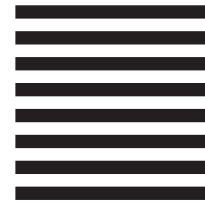

Fold and Tape

Please do not staple

Fold and Tape



Updated April 2, 2009

GA27-4151-07



Free Manuals Download Website

<http://myh66.com>

<http://usermanuals.us>

<http://www.somanuals.com>

<http://www.4manuals.cc>

<http://www.manual-lib.com>

<http://www.404manual.com>

<http://www.luxmanual.com>

<http://aubethermostatmanual.com>

Golf course search by state

<http://golfingnear.com>

Email search by domain

<http://emailbydomain.com>

Auto manuals search

<http://auto.somanuals.com>

TV manuals search

<http://tv.somanuals.com>