



User's Manual

Fire Alarm Back-up UPS1481 UNIT

Emergency Power Systems

Doc #. 6002-1646
Revision X8

Installation and Operating Documentation

OnLine Power

FIRE ALARM BACK-UP UPS1481 UNIT,

Congratulations on selecting one of the fine products from On-Line Power, the Leader in Power Protection Technology. Our wide product offering includes Uninterruptible Power Systems (UPS), Power Conditioners, Automatic Voltage Regulators and Specialty Transformers (e.g. computer-grade, medical-grade). Since our beginning, On-Line Power has shipped many of these fine products around the world, to discerning customers, for use on sensitive equipment and critical applications. Our customers, both new and long-time, continue to enjoy security and peace of mind as they realize what it means to "When the lights go out, we turn on".

One of our goals is to make these manuals both comprehensive and easy to use. This **new-format** Technical Manual is the result of ideas and inputs from customers who have taken an active interest in our continued success. We invite constructive feedback on our products and documentation via fax, mail or telephone.

HEADQUARTERS

On-Line Power
5701 Smith Street
Commerce, CA 90040

SALES

Phone (800) 227-8899
Phone (323) 721-5017
FAX No. (323) 721-3929
email: sales@onlinepower.com

Office Hours
7:30 AM to 5:00 PM PST

**On-Line Power, Inc.
Proprietary Reproduction or Distribution forbidden**

**NOTICE: THIS DOCUMENT CONTAINS PROPRIETARY
INFORMATION**

This document contains proprietary and confidential information of On-Line Power, Inc. ("On-Line Power"). In consideration of the receipt of this document, the recipient agrees not to copy any of its contents, nor disclose them to or allow them to be used by any person not currently a On-Line Power employee or an employee of the recipient having a need to know, without the express written consent of On-Line Power, and further agrees to surrender this document to On-Line Power when the reason for its receipt has terminated.

SAFETY

Safety precautions are important when operating or servicing electrical equipment. The following symbols are used extensively throughout this manual. Always need these precautions since they are essential to the safe operation and servicing of this product.



THIS DANGER SYMBOL IDENTIFIES A CONDITION OR ACTION WHICH WILL RESULT IN SEVERE INJURY OR DEATH TO AN INDIVIDUAL OR SEVERE DAMAGE TO EQUIPMENT OR OTHER PROPERTY.



This Caution symbol identifies a condition or action which may result in minor injury to an individual or minor damage to the equipment or other property.

This unit was designed for specific applications. It should **not** be modified and/or used for any application other than for that which it was designed. Optional equipment not described in the sales literature or this manual should not be installed without first checking with the Service department. If you have any questions about this unit's application call the Service department at the number shown on the previous page.

IMPORTANT SAFETY INSTRUCTIONS SAVE THESE INSTRUCTIONS

This technical manual contains important instructions for models WR3.0, W5.0R, WR7.5, WR010, WR012 and WR015 that should be followed during installation and maintenance of the UPS and batteries.

TABLE OF CONTENTS

SECTION		PAGE
SECTION 1	OPERATION	1
1-1	INTRODUCTION	1
1-2	BENEFITS	2
1-3	PRODUCT FEATURES	1, 5
1-4	CUSTOMERS CONNECTIONS	6-9
1-5	Fire Alarm Back-up UPS1481 SIZING	9
1-6	OUTPUT LOADS	9
1-7	OPTIONS	9
SECTION 2	PREINSTALLATION	11
2-1	SITE PLANNING AND PREPARATION	12
2-1-1	LOCATION CONSIDERATIONS	13
2-2	PRE-INSTALLATION	14
2-3	ELECTRICAL CONNECTIONS	14
2-3-1	REMOTE SIGNALING CONNECTIONS	15
2-4	STORAGE	16
SECTION 3	OPERATION	18
3-1	START-UP PROCEDURES	18
3-2	OPERATION	19
3-2-1	TURN-ON THE Fire Alarm Back-up UPS1481	19
3-2-2	TURN-OFF THE Fire Alarm Back-up UPS1481	19
3-3	THEORY OF OPERATION	19-20
3-4	COMPONENT LOCATION	22-24
3-5	MAJOR COMPONENTS	25
3-5-1	CONTROL BOARD	25
3-5-2	OTHER PARTS	25
3-5-3	HEATSINK ASSEMBLY	25
APPENDIX A -	EXTENDED BATTERY RUN CHART	26
APPENDIX B -	OPTIONAL MAIN INPUT & OUTPUT CIRCUIT BREAKER	27-28
APPENDIX C -	LCD DISPLAY MENU AND TROUBLE SHOOTING	29-31
APPENDIX D -	SPECIFICATIONS.	32-33
S/D:6120-795, 6120-796		34-35
BATTERY DIAGRAMS		36-43

REVISION HISTORY

<u>REV</u>	<u>DATE</u>	<u>PRIMARY REASON FOR CHANGE</u>
X1	APRIL 4, 2004	RELEASE FOR PRODUCTION
X2	FEB 22, 2005	RELEASE FOR PRODUCTION
X3	OCT 30, 2006	UPDATE
X4	NOV 03, 2006	UPDATE P11, P29.
X5	MAY 21, 2007	UPDATE
X6	JUN 21, 2007	UPDATE
X7	Nov. 15, 2007	Per UL Review
X8	MAY 30, 2008	PER UL REVIEW

LIST OF EFFECTIVE PAGES

<u>PAGE</u>	<u>REV</u>	<u>PAGE</u>	<u>REV</u>	<u>PAGE</u>	<u>REV</u>
a	X7 X8				
ii	X7 X8				
1	X7 X8				
5 - 9	X7 X8				
12 - 13	X7 X8				
18 - 19	X7 X8				
22	X7 X8				
26 - 27	X7 X8				
29	X7 X8				
31-40	X7 X8				

SECTION 1 _ OPERATION

1-1 INTRODUCTION

The Fire Alarm Back-up UPS1481 provides an exceptional level of load protection and monitoring capabilities. The critical load is provided with conditioned, regulated, computer grade power at all times. There is complete electrical isolation between the input and output voltage of the UPS.

When input power to the UPS is lost, such as during a power outage, the UPS automatically draws power from its internal battery supply. The critical load receives only clean sine wave power. There are no disturbances or power interruptions on the output when the UPS transfers to battery operation. Transfers to and from battery operation are “No Break” transfers. The internal maintenance-free batteries provide ten (10) to fifteen (15) minutes (depending upon model) of backup power. The 10 and 15 kVA models have separate battery cabinets.

Upon restoration of input power, the UPS automatically resumes normal operation. Also the UPS immediately begins to recharge the batteries.

The Fire Alarm Back-up UPS1481 provides comprehensive monitoring capabilities. In addition to the LED indicators and audible alarm, the Fire Alarm Back-up UPS1481 contains a 160 alpha-numeric display and touch pad. UPS status, event history, and operating parameters (such as input, output voltage) are readily available to the operator via the touch pad and display. The UPS 1481 contains, as standard features, an AS/400 interface, RS-232 interface, and printer interface.

The Fire Alarm Back-up UPS1481 is an on—line single phase UPS available in output ratings of 3, 5, 7.5, 10, 12.5 and 15kVA. The UPS 1481 is U.L. listed under UL1481. The Fire Alarm Back-up UPS1481 is available with input voltages of 120 and 240/VAC and output voltages of 120/240/VAC. This information is provided on the name plate located on the rear panel of the UPS. See Appendix A for a complete listing of the UPS 1481 specifications.

1-2 BENEFITS

The Fire Alarm Back-up UPS1481 is designed to fit the needs of virtually all power conditioning and UPS applications. It has been specifically designed to power all forms of modern data processing, communication, and process control equipment. The Fire Alarm Back-up UPS1481 does not require any decorating as other UPS products may when powering 100% electronic loads including switch—mode power supplies.

The Fire Alarm Back-up UPS1481 protects sensitive electrical equipment, such as computer systems, telecommunication networks, LANs and multi—user systems, and instrumentation

OnLine Power

systems, from electrical interference. The Fire Alarm Back-up UPS1481 protects these systems from power problems associated with poor quality AC power including complete power Outages. Electrical disturbances can come from practically anywhere: from the incoming power lines and even from within a building. Outside electrical disturbances include lightning strikes, utility switching, brown—outs, and accidents. Electrical disturbances from within a building can be caused by load cycling (elevators, HVAC systems), fault conditions, welders, and other electrically noisy equipment. Whether the electrical disturbances are generated outside or from within the facility, the following power problems will occur:

1-3 PRODUCT FEATURES

The following describes the major blocks within the Fire Alarm Back-up UPS1481. Please refer to Illustration. Block Diagram for additional information.

Bypass Static Switch — The SCR solid state switch bypasses the complete UPS and provides utility input directly to the load in case of problem with UPS. This switch also supplies input power to the load during the start up. It is connected on the primary side of the optional output isolation Transformer, when used. This switch maintains it's status opposite of that of the output SCR solid state switch.

Output Static Switch — This SCR solid state switch connects the output of the inverter (UPS) to the load. It is connected on the primary side of the optional output isolation transformer, when used. This switch shuts—off in case of a problem or failure within the UPS and transfers the load directly to the utility input via bypass static switch. It maintains it's status opposite to that of bypass switch.

Power Board with IGBTs — The Power board is bolted onto the IGBT blocks that are mounted on a heat sink. The complete heat sink assembly with IGBT and power board is replaceable as one part. This assembly processes ail the power, ie. input AC power converted to DC bus, battery power boosted to DC bus and finally DC bus power converted to output AC power using PWM technology for smooth AC Sinewave. The complete heat sink assembly is easily replaceable using only a screwdriver, in case of a catastrophic failure, if required. This board also has the housekeeping power supplies and driver circuits for IGBTs. This board also provides the landing place for all internal input, output, and DC cables as well as it monitors the input-output current for control and metering.

Control Board — The microprocessor with programmable logic controllers and on board memory is located on this board. It is mounted on the door and communicates, controls, and monitors the power board via a ribbon cable. This board also senses the input AC and sends the command to close/open the input contactor, bypass static switch and output static switch. This board also sends all the data to the LCD display panel located on the door. It also has modem, AS400, RS232, and RS485 output capabilities.

LCD Display Panel — This front panel provides all the metering data for input, output and battery; alarm data and UPS status for customer use in a constantly changing and updating, the 3 sets of the screens.

OnLine Power

Optional Output Isolation Transformer — This transformer is provided when the input and output voltages are different, or multiple output voltages are required or an isolation at output is required. The power to the primary of this transformer is selected either from UPS via output static switch and from utility input via bypass static switch. The two static switches toggle on/off as controlled by control board.

Battery Charger — The battery charger maintains the batteries at full charge. After a battery discharge, the charger will automatically recharge the batteries upon restoration of input power.

Battery Bank — The battery bank consists of sealed, maintenance free batteries. The batteries provide emergency power during power outages. The battery bank includes a breaker for overcurrent protection and DC disconnect.

Input Contactor — The input contactor serves several functions. First, the input contactor provides connections for the input power to the UPS. Secondly, the contactor disconnects the input line when an outage occurs so that there is no back feeding of power into the power line. Thirdly, the contactor allows for automatic UPS operation upon a complete discharge of the batteries. No operator intervention is required when power to the Lips is restored after a complete battery discharge.

Control Electronics — The control electronics, utilizing a micro_processor, for monitoring provides all required logic signals within the UPS and interfaces with remote devices via the interface ports such as the AS/400 interface.

OnLine Power

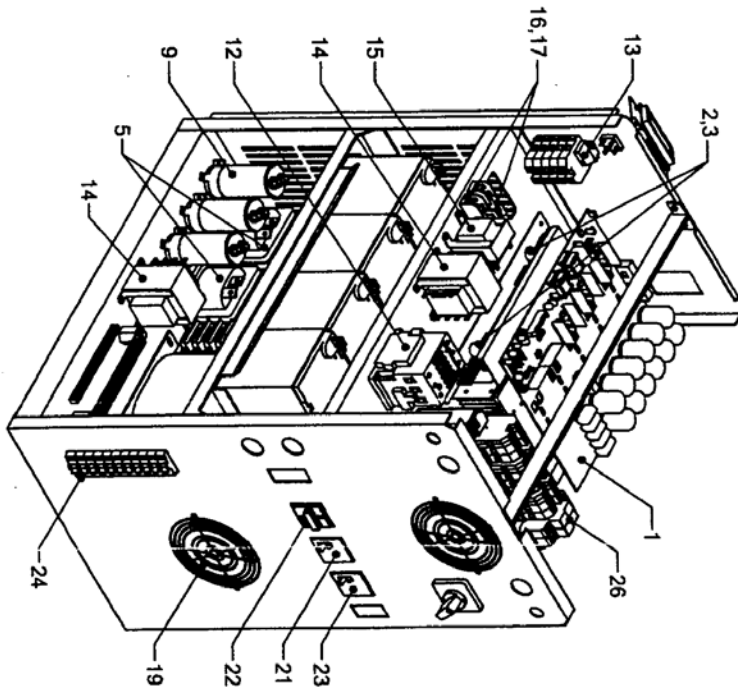
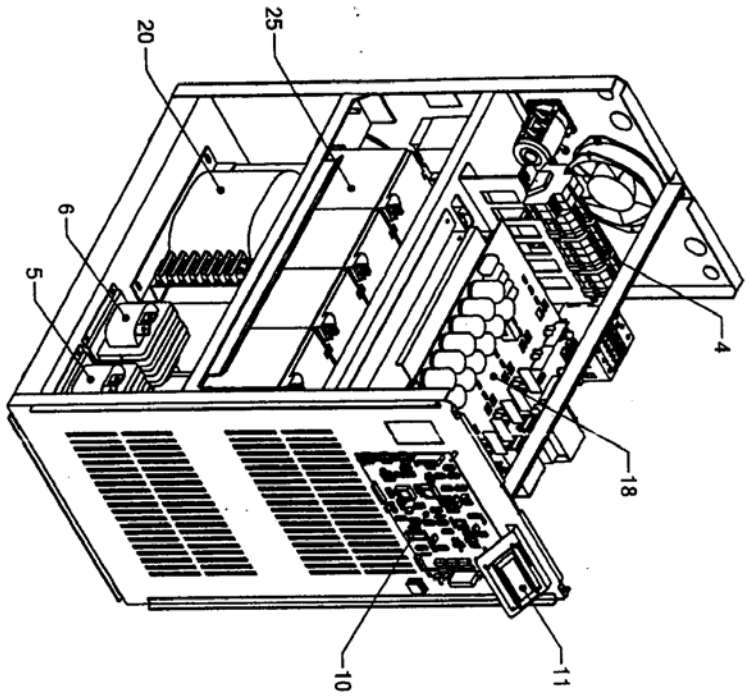

OnLine Power

1-3 FUNCTIONAL BLOCK DIAGRAM (CONTINUED)

THE FUNCTIONAL BLOCK DIAGRAM OF U.P.S.

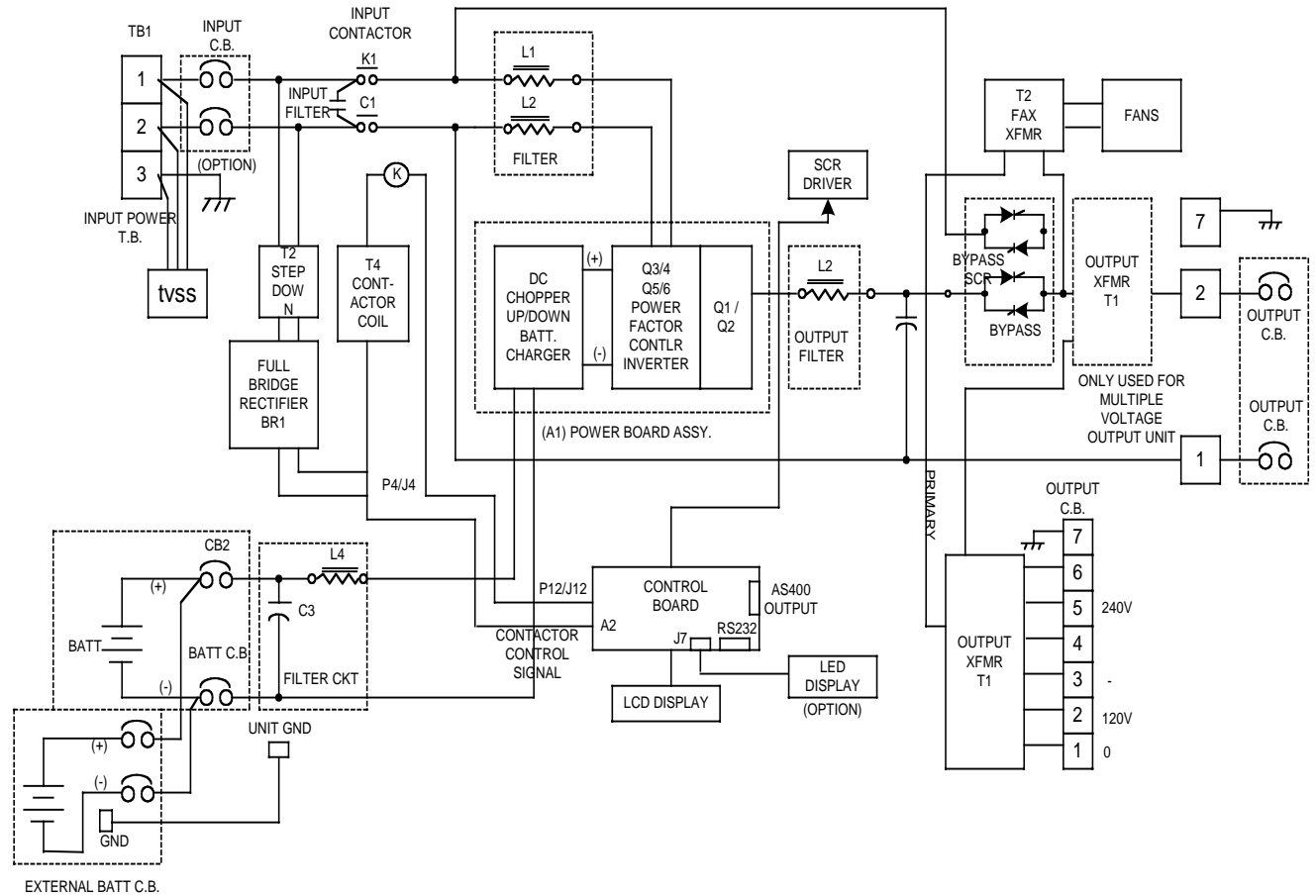

OnLine Power

1-4 CUSTOMERS CONNECTIONS

1-4-1 Input Power Connection by Customer (with no input C/B option)

- Connect input (Hot) at TB-1
- Connect input Hot / Neutral at TB1-2
- Connect input ground at TB1-3

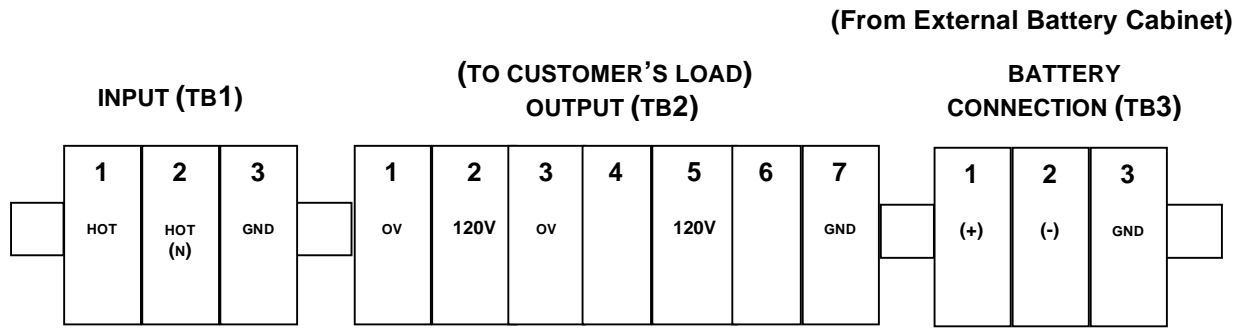

**PROTECTOR CUSTOMER'S CONNECTION TERMINAL BLOCK
ILLUSTRATION 1 - 5**

Input wirings for various input voltages are same.
When input circuit breaker is used, input CB1 is installed in inside of the UPS.

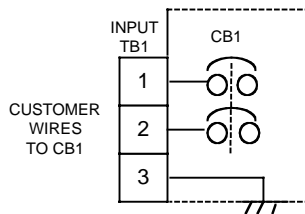

**PROTECTOR CUSTOMER'S CONNECTION TERMINAL BLOCK
ILLUSTRATION 1-6**

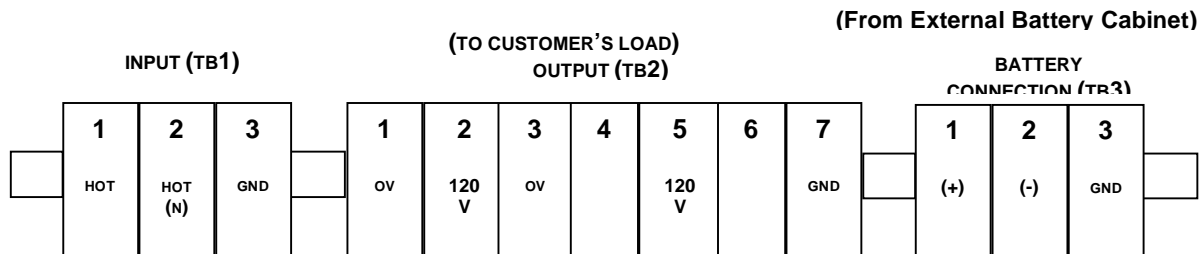

OnLine Power

1-4-2 OUTPUT POWER CONNECTION BY CUSTOMER FOR SAME INPUT AND OUTPUT VOLTAGE UNIT @ WITHOUT OUTPUT XFMR.

1. 120V IN/OUTPUT UNIT

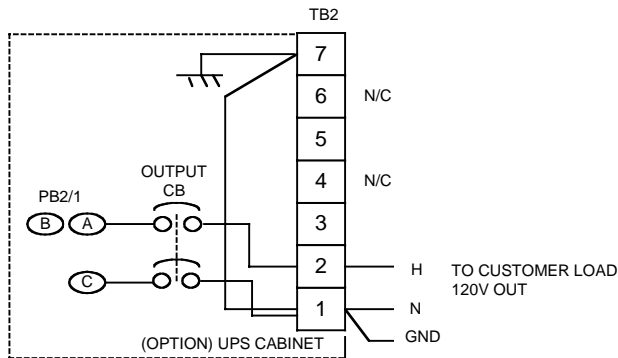

2. 240V IN/OUTPUT UNIT

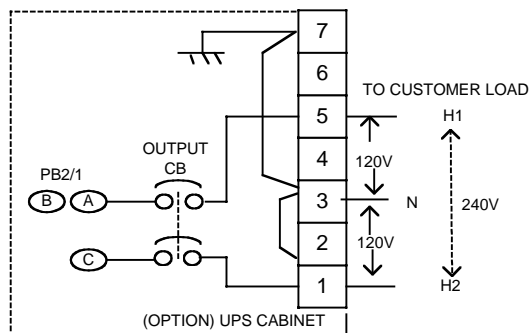

OnLine Power

1-4-3 OUTPUT POWER CONNECTION BY CUSTOMER FOR DIFFERENT INPUT / OUTPUT VOLTAGES USING OUTPUT XFMR.

1. 240V/120 OUTPUT UNIT

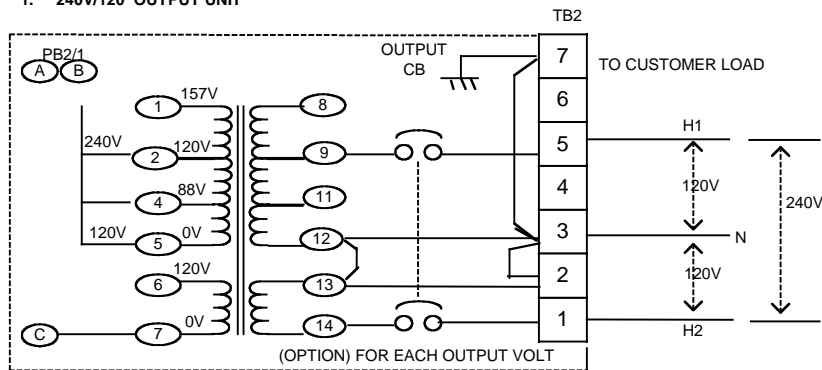

CONNECT TO TB2-1 FOR 120 VOLT UNITS, BUT
240/120V UNIT CONNECT TO TB2-3

2. 120V OUTPUT UNIT

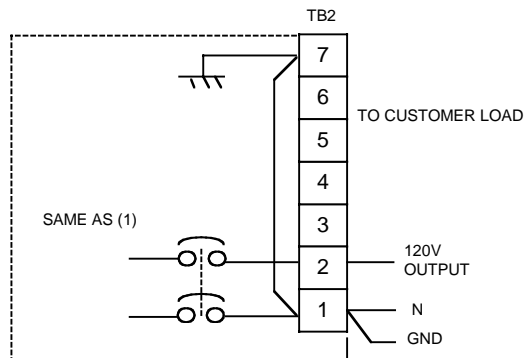

OnLine Power

3. WITH EXTRA AUX. OUTPUT CIRCUIT BREAKERS FOR VARIOUS OUTPUT VOLTAGES.

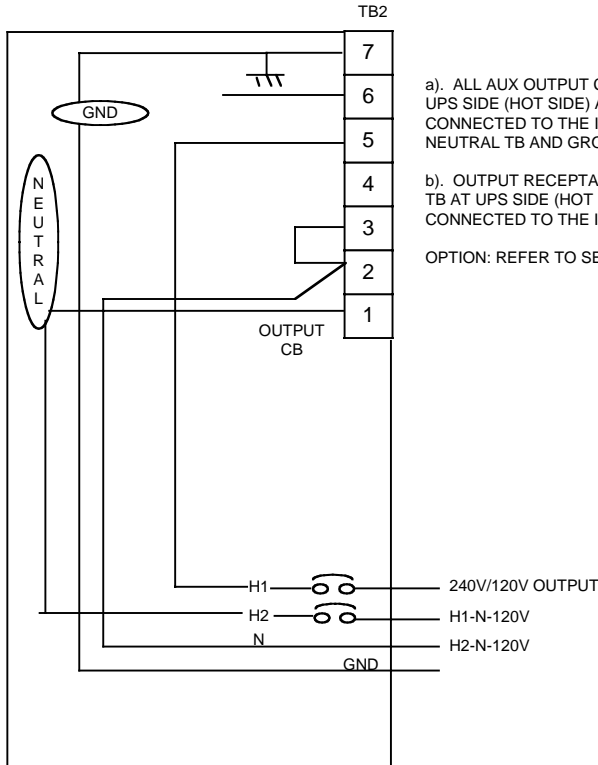

a). ALL AUX OUTPUT CIRCUIT BREAKERS ARE CONNECTED AT UPS SIDE (HOT SIDE) AND CUSTOMER LOAD SHALL BE CONNECTED TO THE INDIVIDUAL AUX CBX NEUTRAL WIRES TO NEUTRAL TB AND GROUND WIRES TO GROUND TB

b). OUTPUT RECEPTACLES ARE CONNECTED TO TB2-OUTPUT TB AT UPS SIDE (HOT SIDE) AND CUSTOMER LOAD SHALL BE CONNECTED TO THE INDIVIDUAL AUX. RECEPTACLES.

OPTION: REFER TO SECTION 4-2

ALL AUX OUTPUT CB
[1P, 20AMP RATED CB'S AS A STANDARD
THE CURRENT AVAILABLE FROM THIS AUX
CB IS LIMITED TO THE TOTAL KW OF EACH
UNIT].

1-5 The Fire Alarm Back-up UPS1481 SIZING

Each model of the Fire Alarm Back-up UPS1481 is designed to supply a maximum load which is given by its kVA (1000's of volt-amperes) and KW rating. It is very important that the load is within the rating of the FIRE ALARM BACK-UP ups1481 to ensure that the connected loads will be properly supported.

Volt - amperes (VA) are the number of current in amps a device draws multiplied by the nominal voltage supplied to the device. The total kVA of all the loads to be connected to the Fire Alarm Back-up UPS1481 is simply the sum of the kVA requirements of each device.

Each electrical device to be powered by the Fire Alarm Back-up UPS1481 should have a specification sheet attached to it which specifies the amount of power it requires. In addition, this information should also be listed in the manual supplied with each piece of equipment. The device's nameplate should list the electrical requirements of the device in some or all of the following units: nominal voltage, current, VA or kVA, and watts or KW. If VA or kVA is not given, then multiply the nominal input voltage by the current shown on the nameplate. Add up the kVA requirements of each device to be powered by the Fire Alarm Back-up UPS1481.

OnLine Power

The total load to be powered by the Fire Alarm Back-up UPS1481 must not exceed its rating. If the total load is exceeded, the Fire Alarm Back-up UPS1481 monitoring will sense an overload condition and a summary alarm will occur. The overload condition must be corrected by increasing the kVA rating of the Fire Alarm Back-up UPS1481.

1-6 OUTPUT LOADS

The Fire Alarm Back-up UPS1481 is designed to power any critical, computer, florescent, or incandescent lighting. There are some types of loads which require an excessive inrush current when first turned on or at other times during its operation.

The capacity of the Fire Alarm Back-up UPS1481 may need to be greater than what would be estimated based on the nameplate requirements of loads previously discussed. Contact your On Line Power dealer or the factory directly if you have any questions about powering unusual loads from your Fire Alarm Back-up UPS1481 .

1-7 OPTIONS

The following options are available with the Fire Alarm Back-up UPS1481 :

AS400 ————
RS232 ————

"Connect to these circuits are to remain in the same room. DB9 connectors on the control PCBD".

Normally On / Off circuit(s) at output.
Extended battery run times.

SECTION 2 . INSTALLATION

2-1 SITE PLANNING AND PREPARATION

The Fire Alarm Back-up UPS1481 is designed for installation indoors and meets NEMA specifications for operating temperature, humidity, and utility voltage. These cabinets are corrosion resistant and rugged. The footprint of the Fire Alarm Back-up UPS1481 is less than 6 square feet. Listed below are the environmental specifications for the Fire Alarm Back-up UPS1481.

Adequate clearance in the front of the equipment should be provided for service access.

OPERATING ENVIRONMENT

- AMBIENT TEMPERATURE 0°C to 49° C
- OPERATING ALTITUDE 1,829 M (6,000 FT) DERATE 10% FOR EACH ADDITIONAL 305 M (1,000 F~) UP TO 2,744 m (9,000 FT)
- RELATIVE HUMIDITY 0% to 95% (non-condensing)

Operating the Fire Alarm Back-up UPS1481 and batteries at either extreme of the temperature range may affect the long-term reliability of the system. This is especially true of the sealed, maintenance-free batteries. Sealed, maintenance-free batteries are designed to operate at normal room temperatures (72 to 77°F).

STORAGE ENVIRONMENT.

Provide a storage environment which meets the following conditions:

- AMBIENT TEMPERATURE -30°C to 70°C
- RELATIVE HUMIDITY 0% to 95% non-condensing

**TABLE 2-1
SITE PLANNING SPECIFICATIONS FOR KVA UNIT**

	MODEL NUMBER	IKW / kVA	INPUT VOLTAGE	INPUT AMP	OUTPUT VOLTAGE	OUTPUT AMP		DC VOLT	DC AMP	QTY. BATT PER SET	APPROX. W/O BATT WEIGHT
1	WR3.0A58FPT1	3.0	120	40	120/240	25.00	@120	96V	43A	8	
2	WR3.0B58FPT1	3.0	208	19	120/240			96V	43A	8	
3	WR3.0D58FPT1	3.0	240	19	120/240	12.50	@240	96V	43A	8	
5	WR5.0A58FPT1	5.0	120	58	120/240	41.70	@120	120V	57A	10	
6	WR5.0B58FPT1	5.0	208	30	120/240			120V	57A	10	
7	WR5.0D58FPT1	5.0	240	30	120/240	21.00	@240	120V	57A	10	
9	WR7.5B58FPT1	7.5	208	44	120/240	62.5	@ 120	120V	86A	10	
10	WR7.5D58FPT1	7.5	240	41	120/240	31.3	@240	120V	86A	10	
12	WR010B58FPT1	70.0	208	44	120/240	83.0	@ 120	192V	71A	16	
13	WR010D58FPT1	10.0	240	58	120/240	41.5	@240	192V	71A	16	
15	WR012B58FPT1	12.5	208	73	120/240	104.2	@ 120	192V	88A	16	
16	WR012D58FPT1	12.5	240	69	120/240	52.1	@240	192V	88A	16	
18	WR015B58 FPT1	15.0	208	85	120/240	125.0	@ 120	240V	84A	20	
19	WR015D58FPT1	15.0	240	83	120/240	62.5	@240	240V	84A	20	
21	WR3.0A01FPN1	3.0	120	40	120	25.00	@ 120	96V	43A	8	
22											
23											
25	WR5.0A01FPN1	5.0	120	58	120	41.70	@ 120	120V	57A	10	
26											
27											
29											
30											
32											
33											
35											
36											
38											
39											

NOTE: FP DENOTES – FIRE PROTECTION Fire Alarm Back-up UPS1481 SERIES.

OnLine Power

UL1481 MICRO-CHIPS & OTHER COMPONENT'S LIST

	MODEL NUMBER	INPUT KW / KVA	OUTPUT VOLTAGE	MICRO-CHIP SOFTWARE	BASIC UPS KIT	LABEL KIT	INPUT CONTACTOR	BATT C.B.	FANS
1	WR3.0A58FPT1	120	120/240V	9100-1319-018UL	9100-1312-11	9100-1295-02	1680-242	2025-769	1000-036
2	WR3.0B58FPT1	208	120/240V	9100-1319-023UL					
3	WR3.0D58FPT1	240	120/240V	9100-1319-025UL	9100-1312-11	"	"	"	"
5	WR5.0A58FPT1	120	120/240	9100-1319-050UL	9100-1312-11	"	1680-093	2025-768	"
6	WR5.0B58FPT1	208	120V/240	9100-1319-055UL	9100-1312-11	"	"	"	
7	WR5.0D58FPT1	240	120/240	9100-1319-057UL	9100-1312-11	"	"	"	"
9	WR7.5B58FPT1	208	120/240	9100-1319-77UL	9100-1312-11	"	1680-093	2025-759	"
10	WR7.5D58FPT1	240	120/240V	9100-1319-081UL	9100-1312-11		"	"	
11						"	"	"	"
12	WR010B58FPT1	208	120/240V	9100-1319-101UL	9100-1312-11	"	1680-139	2025-772	
13	WR010D58FPT1	240	120/240	9100-1319-105UL	9100-1312-11	"	"	"	"
14									
15	WR012B58FPT1	208	120/240	9100-1319-125UL	9100-1312-11	"	1680-187	2025-759	
16	WR012D58FPT1	240	120/240	9100-1319-129UL	9100-1312-11	"	"	"	
17									
18	WR015B58FPT1	208	120/240	9100-1319-149UL	9100-1312-11	"	"	"	
19	WR015D58FPT1	240	120/240V	9100-1319-153UL	9100-1312-11	"	"	"	"
20									
21	WR3.0401FPN1	120	120	9100-1319-017UL	9100-1312-10	"	1680-242	2025-769	"
25	WR5.0A01FPN1	120	120	9100-1319-049UL	9100-1312-10		1680-093	2025-768	

MODEL PART NUMBER NOMENCLATURE

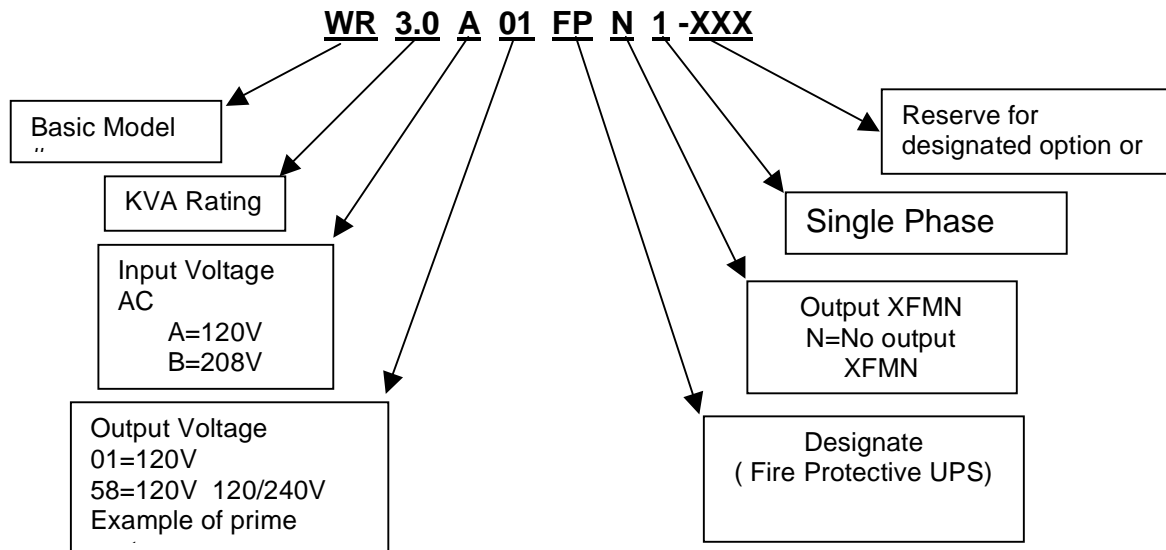

OnLine Power

2-2 Pre-Installation

The Fire Alarm Back-up UPS1481 is designed for indoor installations. All customer connections are brought through knockouts located on the top or side of the Fire Alarm Back-up UPS1481. The Fire Alarm Back-up UPS1481 consists of one (1) integrated cabinet — housing both the electronics and batteries (depending on KVA). Before unpacking the equipment, inspect the exterior the shipping container and the equipment itself for damage that may have occurred during transit. If the shipping container or equipment itself shows evidence of damage, note the damage on the receiving document before signing for receipt of the equipment. Damage claims should be filed directly with the carrier.

2-2-1 Equipment Unpacking

Remove the equipment from the shipping carton. Since the 68” cabinet for 15KVA is designed for pad — mount installations, there are no casters. It is suggested that a fork lift be used to remove the Fire Alarm Back-up UPS1481 from its shipping pallet. Before placing the Fire Alarm Back-up UPS1481 onto the mounting bolts or leveller (where it will be installed), the conduit knockouts needs to be removed.

1. The conduit knockouts are located on the back-side of the cabinet for 3-15 KVA
2. Remove the conduit knockouts.
3. Measure the locations for the conduits on the conduit knockouts.
4. Drill or punch holes in the conduit knockouts for the conduits.

Anchor the Fire Alarm Back-up UPS1481 to the mounting pad at the four (4) mounting locations, by lowering levellers for 3-15 KVA units.

1. Anchor the conduits to the conduit knockouts
2. This concludes the mechanical installation.

2-3 Electrical Connections: “CAUTION & DE-ENERGIZE UNIT PRIOR TO SERVICING”

CAUTIONS CAUTION

Verify that all customer-supplied wiring is de-energized before performing any electrical work,

CAUTIONS CAUTION

Even when the Fire Alarm Back-up UPS1481 is off, there are potentially dangerous voltages within the Fire Alarm Back-up UPS1481 due to the batteries. Extreme care must be taken when working within the Fire Alarm Back-up UPS1481 enclosure.

OnLine Power

1. Verify that the main input circuit breaker, battery circuit breaker, and output circuit breaker(s), if provided are in the "OFF" position. See illustration 1-2 for the locations of the circuit breakers. See under Section 2-5, Storage for accessing the inside of the unit.
2. Run the power wires up through the center area of the Fire Alarm Back-up UPS1481. Exercise care when working around the battery area.
3. Refer to Section 1-4 for various different installation configurations.
4. Connect the input wires to the input terminal block, TB1. Three (3) wires total: "hot", neutral (or Hot), and ground.
5. Connect the output wires to the output terminal block, TB2. Three (3) wires total: "hot", neutral (or Hot), and ground to the appropriate designate locations.
6. Connect the battery wires from external battery cabinet (if provided) to battery terminal block, TB3, three (3) wires total for (+), (-) and Ground.
7. This concludes the electrical connections. Do not apply power to the Fire Alarm Back-up UPS1481 at this time.

2-3-1 Remote Signaling Connections (AS400)

The Fire Alarm Back-up UPS1481 includes the feature of providing dry relay contacts for remote signaling capabilities. Signals available of remote annunciation are:

"UTILITY FAILURE" — This is a normally open contact which closes upon loss of input power to the Fire Alarm Back-up UPS1481 . **"LOW BATTERY"** — This is a normally open contact which closes when the Fire Alarm Back-up UPS1481 is on battery operation and the batteries are approaching complete discharge.

"ON INVERTER or ON BYPASS" — This is a normally open contact which closes when the Fire Alarm Back-up UPS1481 goes to battery operation.

"SUMMARY ALARM" — This is a normally open contact which closed when the Fire Alarm Back-up UPS1481 has any one of the alarm condition.

If there are no requirements for remote signaling, section 2-4-1 may be skipped.

1. The dry relay contacts for remote signaling are provided on connector (P5) of control board (A2) located on the right door inside of the Fire Alarm Back-up UPS1481. See illustration 1-2 for exact locations.
2. The dry relay contacts have the following maximum ratings:
200V (AC or DC) maximum
1.25 amperes maximum
30 watts /50 VA maximum, Power Factor 1.0PF
It is imperative that the relay contact ratings are not exceeded. Otherwise, damage to the relays within the Fire Alarm Back-up UPS1481 will occur.

OnLine Power

During long-term storage, the batteries are subject to aging and deterioration. If after visual inspection, the batteries need to be replaced contact your OnLine Power dealer or the OnLine Power factory directly to obtain new batteries.

The UPS is stored in its original packaging, unpack UPS using unpacking procedures outlined in Section 2-3-1.

If the UPS is not connected to a source of power, first connect the UPS to an appropriate source of power using the procedures in Section 2-4, Electrical Connections.

When the UPS is unpacked and first connected to an AC power source, recharge batteries as follows:

1. Unlock and remove the front panel by pushing it up and out, pull both the side panel up and out.
2. Visually inspect batteries for signs of deterioration and leakage. Replace batteries if required.
3. Set AC power source to ON.
4. Close input CB, if provided (CB2)
5. Close battery CB, if provided (CB1)
6. The UPS automatically recharges batteries. The LCD panel will indicate the battery voltage and charging current.
7. Allow UPS to run for 24 hours to fully charge batteries.
 - When batteries have reached partial charge, the battery charging current will be under 1 Amps on LCD panel.
8. Turn OFF input power to the UPS.
9. Close and replace all the panels back.

SECTION 3 . OPERATION

3-1 Start-Up Procedures

1. Verify that the main input circuit breaker, battery breaker, and output circuit breaker(s), if provided, are in the “OFF” or “down” positions.

Refer to illustration 1-2 for the locations of the circuit breakers.

CAUTION CAUTION

It during the start- up procedures anything unusual occurs, immediately turn off the Input circuit breaker, and contact OnLine Power at (800) 797-7782 for technical assistance. If there are any questions or additional information Is required, please contact On-Line Power at (800) 797-7782 for technical assistance.

2. Apply input power to the Fire Alarm Back-up UPS1481 Series
 - Verify that the voltage appearing on the input terminal block is 120/240 VAC and is same as on nameplate. lithe voltage is not same as on nameplate approximately, do not proceed any further. Contact On-Line Power at (800) 797-7782 for technical assistance.
 - Verify that there are no voltages appearing on the output terminal block.
3. Turn on the main input circuit breaker, supplying power to the unit.
4. After turning on the System, wait one (1) minute while the Fire Alarm Back-up UPS1481 runs through its internal diagnostic routines.
 - Hear the sound of contactor closing.
 - See the fan(s) running.
 - See the LCD panel displaying correct messages. See Appendix D for LCD displays.
 - Verify that the LCD display panel indicates all correct parameters — see Appendix D for details.
 - Verify that the output voltage is 120/240 per the nameplate.
5. Close battery breaker in the UPS cabinet [and in battery cabinet(s), if provided.

OnLine Power

6. At this point in time, the Fire Alarm Back-up UPS1481 should be providing AC line power. The Fire Alarm Back-up UPS1481 is not operating in the normal mode, turn off the input circuit breaker. Contact OnLine Power at (800) 797-7782 for technical assistance.
 7. Recheck that the output voltage is 120/240 VAC.
 - If the output voltage is approximately same as nameplate, turn on the loads which will be powered from the Fire Alarm Back-up UPS1481 .
 8. The next steps verify battery operation and the inverter test switch.
 - To place the Fire Alarm Back-up UPS1481 in battery operation (to simulate loss of input power), press and hold yellow Inverter Test Switch. With switch in the hold position, the Fire Alarm Back-up UPS1481 should be running on its internal batteries.
 - Verify that the LCD panel displays such.
 - Verify that the “Battery Charger” is OFF in LCD panel.
- Note: Be sure to release the switch, after the test, so it will not deplete the batteries.
9. The Fire Alarm Back-up UPS1481 is now fully functional - providing clean, sine wave power to the load with battery back—up in case of an input power failure. This concludes the start-up procedures.

3-2 Operation

3-2-1 Turning On the Fire Alarm Back-up UPS1481 :

1. Apply input power.
2. With input power available, turn on the main input circuit breaker, CB2 (if provided).
3. Close battery breaker (CB1), only after the LCD display is lit & displays screens per Appendix D.
4. Wait till you hear the input contactor closing and fan running.
5. Verify that all parameters on LCD display panel are proper. See Appendix D for display details.
6. Close the output circuit breaker, CB2 (if provided).
7. Turn load breakers On.

OnLine Power

3-2-2 Turning off the Fire Alarm Back-up UPS1481 :

1. Turn off the Output Breaker(s), if provided.
2. Turn off the Battery Breaker.
3. Turn off the Input Breaker, if provided.

3-3 Theory of Operation

Illustration NO TAG is a simplified block diagram of the Fire Alarm Back-up UPS1481. This diagram provides an excellent tool in identifying the major building blocks within the Fire Alarm Back-up UPS1481 .

1. **External Main input circuit breaker (CB2)** — The main input circuit power provides overcurrent protection to the input side of the Fire Alarm Back-up UPS1481 .
2. **Input Contactor (KI)** — The microprocessor based control circuitry:
 - Verifies UPS to be normal condition and not the one 'at fault'.
 - Verifies correct input voltage and frequency to be within acceptable range and commands the closure of this. Contactor via control transformer T2 and fuse FI.
3. **Input Chokes (LI, U)** — They act as a filter and an important circuitry of an up chopper, boosting input voltage to a higher internal DC bus voltage.
4. **Battery charger** — The battery charger converts AC power into regulated DC power to charge and to maintain the charge on the battery bank. The charger is fully automatic with a current limiting feature so that damage will not occur to the batteries in case of a charger malfunction. The charger is sized such that the batteries will be maintained at full charge even when the input voltage is at the low line limit for indefinite periods of time.
5. **Battery** — The battery bank, consisting of eight (8), ten (10), sixteen (16), or twenty (20), 12 volt, VRLA batteries, provides the reserve energy to power the load when suitable AC input power is not present. The batteries are sealed, maintenance—free construction.
6. **Inverter** — When the AC input power is not available to power the load, the inverter converts the energy stored in the battery bank to AC power to supply the powers the load. The pulse width modulated (PWM) inverter utilizes high speed, high efficiency IGBT5 for fast response, sinusoidal power.
7. **DC Choke (U)** — If helps boosting battery voltage to an internal higher DC bus voltage.
8. **Output AC Choke (L4)** — This acts as a buck circuit component connecting high DC bus voltage to an appropriate AC output voltage.

OnLine Power

9. **Optional Output Isolation Transformer (T1)** — The transformer performs a number of critical functions. First, it provides excellent common mode and normal mode noise isolation of the load from the input or inverter power. Secondly, it provides voltage transformation and tight regulation of the output voltage while the Fire Alarm Back-up UPS1481 is operating from its internal inverter or directly from utility via bypass circuitry.
10. **Inverter Test Switch (SW2)** — This switch is a manually operated switch which tests the Fire Alarm Back-up UPS1481 and the batteries for proper operation. When the Fire Alarm Back-up UPS1481 is running and Switch SW2 is pushed and held in, the Fire Alarm Back-up UPS1481 will automatically transfer to battery operation. The Fire Alarm Back-up UPS1481 will continue to run on batteries until the switch is released back to the “normal” position (Switch is a momentary switch). When the switch is released, the Fire Alarm Back-up UPS1481 returns to normal operation (provided input power is present).
11. **Control Transformer (T2)** — This transformer with fuse (F1), provides (internal housekeeping) power supply as well as 120 VAC for the coil of the input contactor. The primary of this transformer has various taps that needs to be matched with the various input voltages.
12. **Fan Transformer (T3)** — This transformer with fuse (F2) provides 120 VAC to the fan(s) for various output voltages that are matched at its primary taps.

3-4 COMPONENT'S LOCATION & LIST

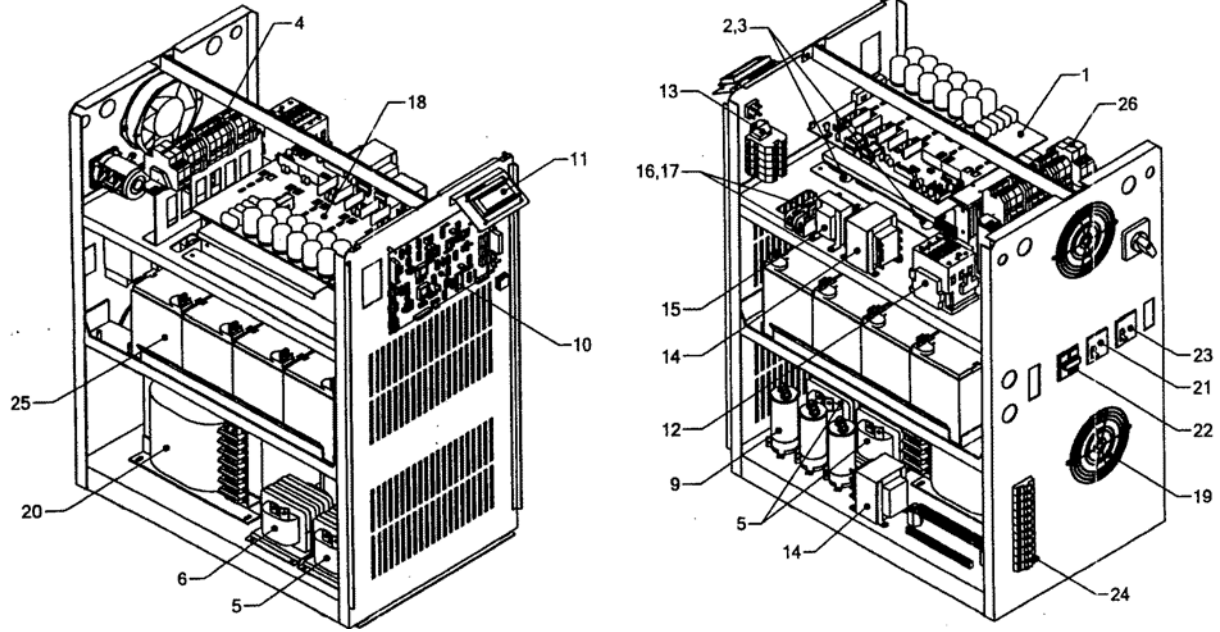

COMPONENT'S TABLE

ITEM	QTY	DESCRIPTION	DESIG.	OLP PART NUMBER
1	1	Power Board	A1	1625-287-01
2	1	Bypass Static Switch	PB1	1690-002
3	1	Output Static Switch	PB2	1690-002
4	1	Input/Output/Battery Terminal Block for customer's use	TB1, TB2, TB3	4025-210
5	1	Input Choke / output choke	L1, L2, L3	1450-1470-03
6	1	DC choke	L4	1450-1472-03
9	1	The Frequency Noise Filter Capacitors for Input Power	C1, C2, C3	1525-206
10	1	Control Board	A2	1625-288-01
11	1	LCD Display Board	A5	1690-164
12	1	Input Contactor	K1	1690-242/ -093/ -139/ -187
13	1	Terminal Block to remove heat sink assembly	TB4	4025-211
14	1	Fan Transformer	T3	1400-110
15	1	Control Power Transformer	T2	1400-105
16	1	Control Transformer Fuse	F1	2075-024
17	1	Fan Fuse	F2	2075-065
18	1	Heat Sink Assembly	HS1	9100-1338-01 THRU -04
19	1	Fan(s)	B1, B2	1000-036
20	1	Optional Output Isolation Transformer	T1	1450-1473-06
21	1	Input Breaker	CB2	OPTIONAL, SEE NAMEPLATE
22	1	Battery Breaker	CB1	2025-XXX, CONSULT FACTORY
23	1	Output Breaker	CB3	OPTIONAL, SEE NAMEPLATE
24	1 +	Output Distribution Breakers	CB4 and UP	OPTIONAL, SEE NAMEPLATE
25	8, 10, 16, 20	Maintenance Free Lead Acid Battery(s)	B1 and UP	SEE THE NAME-PLATE
26	(TVSS	TVSS	

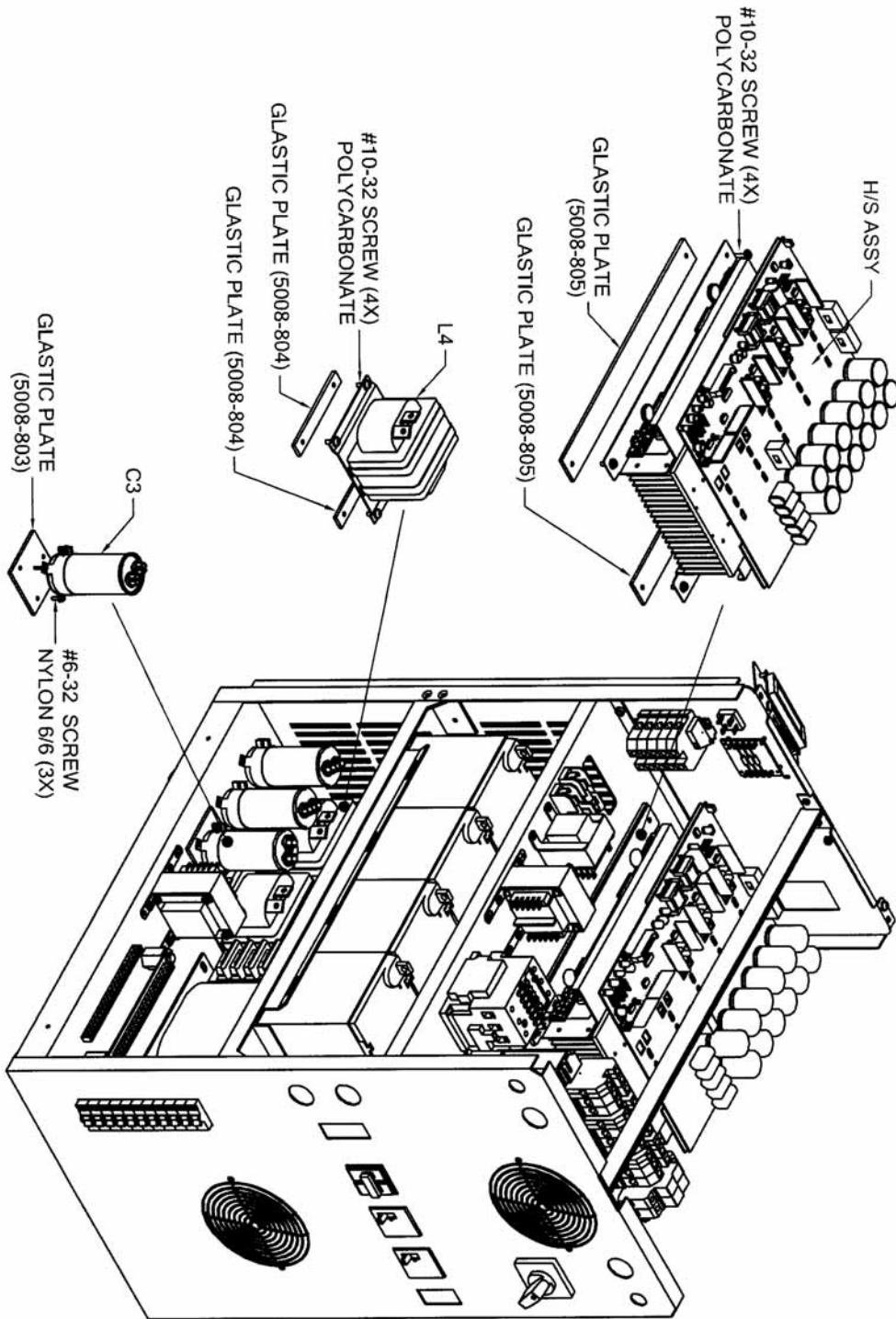

OnLine Power

3-4 ITEM 18 (CONTINUED)

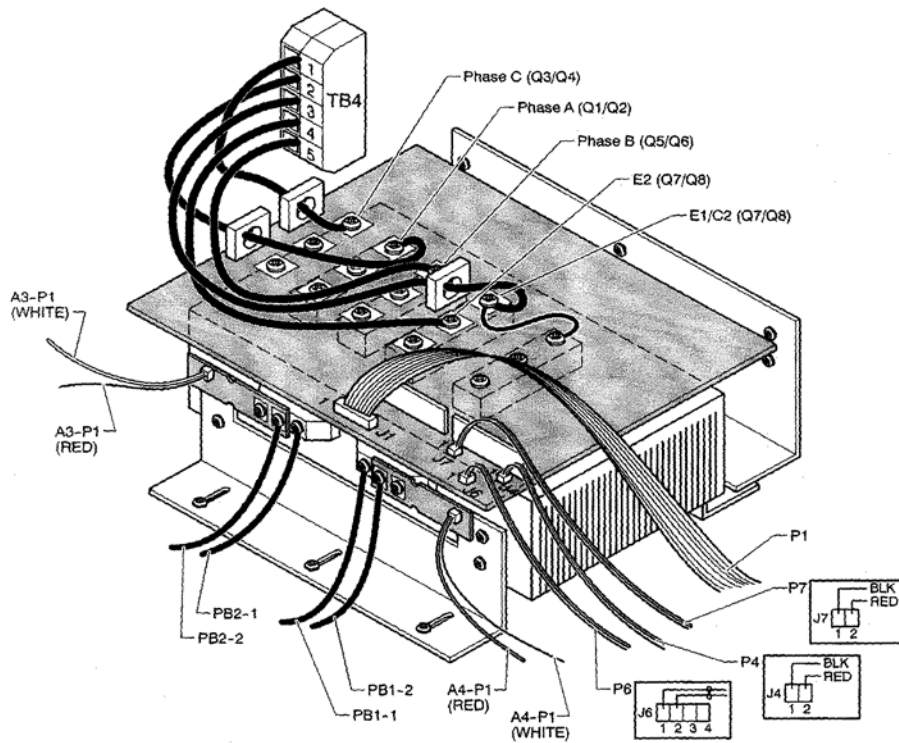

HEAT SINK ASSEMBLY
ILLUSTRATION 3-2

OnLine Power

APPENDIX A: EXTENDED BATTERY RUN CHART

Battery kitPart#	7050-354	7050-355	7050-356	7050-357	7050-358	7050-359	7050-360	7050-361	7050-362-	7050-363-	7050-364-	7050-365-
LoadKV A	0.5	0.75	1.0	1.5	2.0	3.0	4.0	5.0	7.5	10.0	12.5	15.0
Minutes	-015	-015	-015	-015	-015	-015	015	-015	-015	-015	-015	-015
Batt.AH	8x25	8x25	8x25	8x25	8x25	8x35	10x35	10x35	10x50	16x50	16x65	20X50
Cabinet	A	A	A	A	A	A	A	A	A+B	A+B	A+B	A+C
									orA+A			
Minutes	-030	-030	-030	-030	-030	-030	-030	-030	-030	-030	-030	-030
Batt.A.H	8X25	8X25	8X25	8X35	8X35	8X50	10X50	10x65	10x120	16x90	16x120	20x120
Cabinet	A	A	A	A	A	A+B	A+B	A+B	A+B	A+C	A+B	A+C
						orA+A	orA+A	orA+A				
Minutes	-060	-060	-060	-060	-060	-060	-060	-060	-060	-060	-060	-060
Batt.A.H	8X25	8X25	8X35	8X50	8X50	8x90	10x90	10x120	20x90	32x65	32x90	40x90
Cabinet	A	A	A	A+B	A+B	A+B	A+B	A+B	A+C	A+B+C	A+B+C	A+2C
				orA+A	orA+A	orA+A						
Minutes	-120	-120	-120	-120	-120	-120	-120	-120	-120	-120	-120	-120
Batt.A.H	8X35	8x50	8x50	8x90	8x100	16x90	20x90	20x90	30x90	40x120	60x90	60x90
Cabinet	A	A+B	A+B	A+B	A+B	A+C	A+C	A+C	A+B+C	A+2C	A+B+2C	A+B+2C
		orA+A	orA+A	orA+A	orA+A							
Minutes	-240	-240	-240	-240	-240	-240	-240	-240	-240	-240	-240	N/A
Batt.A.H	8x50	8x90	8x100	8x120	16x90	20x120	20x120	30x120	30x120	60x120	80x120	
Cabinet	A+B	A+B	A+B	A+B	A+C	A+C	A+C	A+B+C	A+B+C	A+2C+B	A+B+2C	
		orA+A	orA+A	orA+A	orA+A							
Minutes	-480	-480	-480	-480	-480	-480	-480	-480	-480	-480	N/A	N/A
Batt.A.H	16X65	16X90	16x90	16x120	24x120	40x120	40x120	50x120	100x90	100x120		
Cabinet	A+B	A+C	A+C	A+C	A+C	A+2C	A+2C	A+2C	A+4C	A+4C		
Minutes	-1440	1440	1440	1440	1440	1440	1440	1440	N/A	N/A	N/A	N/A
Batt.A.H	24X 120	24X 120	32X 100	40X 120	50X 120	80X 120	100X 120	100X 150				
Cabinet	A+C	A+C	A+C	A+C	A+2C	A+3C+B	A+4C	A+4C				

Note: 0.5 KVA-3KVA: Load only change using same 3KW unit.
4-5KW: Load only change using 5KW unit.

TABLE 4-10

Battery Part Number Nomenclature.

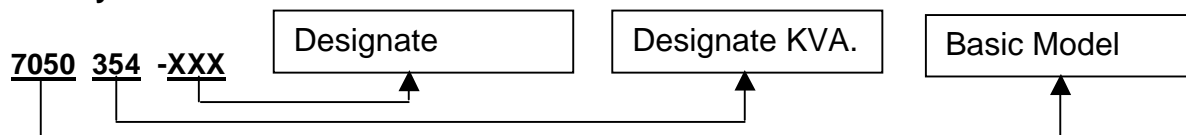

Cabinet Types: **A**=Internal batteries located on the bottom shelf of smal cabinet. **B**=48" Tall,one cabinet.
C=68" Tall,one cabinet **NB**=48" Tall,N number of cabinets **NC**=68" Tall, number of cabinets.

*UL LISTING WAS PERFORMED ONLY FOR 15 MINUTES RUN TIME.

OnLine Power

OTHERS ARE CALCULATED VALUES BASED ON THE BATTERY MANUFACTURER'S DATA FOR BACK UP TIME.

APPENDIX B – Optional Main Input & Main Output Breakers for various models (*All Values are typical as reference only)

TABLE B-1: External Output Breaker (Standard KAIC)				
KVA	Output Voltages			
	120 Vac		240 /120 VAC	
3	40 Amps, 120 VAC, 1 Pole, 14 KAIC OLP P/N: 2025-783		20 Amps, 240 VAC, 2 Pole, 10 KAIC OLP P/N: 2025-788	
5	70 Amps, 120 VAC, 1 Pole, 14 KAIC OLP P/N: 2025-997		40 Amps, 240 VAC, 2 Pole, 10 KAIC OLP P/N: 2025-791	
7.5	100 Amps, 120 VAC, 2 Pole, 10 KAIC OLP P/N: 2025-999		50 Amps, 240 VAC, 2 Pole, 10 KAIC OLP P/N: 2025-792	
10	125 Amps, 120 VAC, 2 Pole, 10 KAIC OLP P/N: 2025-759		70 Amps, 240 VAC, 2 Pole, 10 KAIC OLP P/N: 2025-794	
12.5	1750 Amps, 120 VAC, 2 Pole, 10 KAIC OLP P/N: 2025-468		80 Amps, 240 VAC, 2 Pole, 10 KAIC OLP P/N: 2025-795	
15	200 Amps, 120 VAC, 2 Pole, 65 KAIC OLP P/N: 2025-541		100 Amps, 240 VAC, 2 Pole, 10 KAIC OLP P/N: 2025-797	

TABLE B-2: Output Breaker (High KAIC)				
KVA	Output Voltages			
	120 Vac		240 Vac	
3	40 Amps, 120 VAC, 1 Pole, 42 KAIC OLP P/N: 2025-799		20 Amps, 240 VAC, 2 Pole, 65 KAIC OLP P/N: 2025-762	
5	70 Amps, 120 VAC, 1 Pole, 42 KAIC OLP P/N: 2025-998		40 Amps, 240 VAC, 2 Pole, 65 KAIC OLP P/N: 2025-766	
7.5	100 Amps, 120 VAC, 2 Pole, 42 KAIC OLP P/N: 2025-803		50 Amps, 240 VAC, 2 Pole, 65 KAIC OLP P/N: 2025-767	
10	125 Amps, 120 VAC, 2 Pole, 65 KAIC OLP P/N: 2025-759		70 Amps, 240 VAC, 2 Pole, 65 KAIC OLP P/N: 2025-769	
12.5	1750 Amps, 120 VAC, 2 Pole, 65 KAIC OLP P/N: 2025-468		80 Amps, 240 VAC, 2 Pole, 65 KAIC OLP P/N: 2025-770	
15	200 Amps, 120 VAC, 2 Pole, 65 KAIC OLP P/N: 2025-541		100 Amps, 240 VAC, 2 Pole, 65 KAIC OLP P/N: 2025-894	

INPUT CIRCUIT BREAKER

TABLE B-3: Input Breaker Ampacity (Standard KAIC)				
KVA	Input Voltages			
	120 Vac		240 V/ or 208V	
3	50 Amps, 120 VAC, 1 Pole, 14 KAIC OLP P/N: 2025-784		30 Amps, 240 VAC, 2 Pole, 14 KAIC OLP P/N: 2025-790	
5	70 Amps, 120 VAC, 1 Pole, 14 KAIC OLP P/N: 2025-997		40 Amps, 240 VAC, 2 Pole, 10 KAIC OLP P/N: 2025-791	
7.5	N/A		60 Amps, 240 VAC, 2 Pole, 10 KAIC OLP P/N: 2025-793	
10	N/A		70 Amps, 240 VAC, 2 Pole, 10 KAIC OLP P/N: 2025-794	
12.5	N/A		90 Amps, 240 VAC, 2 Pole, 10 KAIC OLP P/N: 2025-796	
15	N/A		125 Amps, 240 VAC, 2 Pole, 65 KAIC OLP P/N: 2025-759	

TABLE B-4: Input Breaker Ampacity (HIGH KAIC)				
KVA	Input Voltages			
	120 Vac		240 Vac or 208VAC	
3	50 Amps, 120 VAC, 1 Pole, 42 KAIC OLP P/N: 2025-800		30 Amps, 240 VAC, 2 Pole, 65 KAIC OLP P/N: 2025-764	
5	70 Amps, 120 VAC, 1 Pole, 42 KAIC OLP P/N: 2025-998		40 Amps, 240 VAC, 2 Pole, 65 KAIC OLP P/N: 2025-766	
7.5	N/A		60 Amps, 240 VAC, 2 Pole, 65 KAIC OLP P/N: 2025-768	
10	N/A		70 Amps, 240 VAC, 2 Pole, 65 KAIC OLP P/N: 2025-769	
12.5	N/A		90 Amps, 240 VAC, 2 Pole, 65 KAIC OLP P/N: 2025-771	
15	N/A		125 Amps, 240 VAC, 2 Pole, 65 KAIC OLP P/N: 2025-759	

OnLine Power

APPENDIX C: LCD DISPLAY MENU & TROUBLESHOOTING GUIDE

Two screens (A, B) are updated continuously for units without optional output transformer.

Three screens (A, B, C) are updated continuously for units with optional output transformer.

Start-up Screen

When input power is applied for the unit, LCD panel lights up and displays



If LCD display panel is not lit, unit has a problem. Contact factory service at 1-800-PWR-SRVC at OnLine Power.

SCREEN A: The screen appears as below.

Line 1	UPS NORMAL	@	7	KW
Line 2	INPUT OK	@	CHRG	ON
Line 3	BATTERY OK	@	DC	OK
Line 4	ON INVERTER	@	OUT	OK

It may show

1. **UPS** **NORMAL** @ **7KW**
- **7KW** indicates the KW rating of the unit
 - **STANDBY** is shown for testing or startup
 - **NORMAL** indicating normal UPS operation
 - **PROBLEM** UPS having problem
 - Try to reset the unit by shutting off and restarting, or else contact factory
 - **FAILURE** indicates UPS failed or had alarm condition
 - Reset unit as above. Shut it off till LCD is shut-off. Restart unit, or else contact the factory

OnLine Power

SCREEN B: The screen appears as below.

Line 1	OUTPUT: _____ V	@	_____	W
Line 2	INPUT : _____ V	@	_____	A
Line 3	DC BUSS: _____ V	@	NA	A
Line 4	BATT: _____ V	@	+ _____	A

4. Indicates output voltage and power in watts, when output transformer is not used. It indicates primary voltage of the output transformer (T1) (120 VAC, typically) when T1 is used.
5. Indicates input volts and Amps.
6. Indicates internal DC buss condition for factory use.
7. Indicates battery voltage. The (+) current in Amps indicates charging Amps, while (-) indicates discharging Amps.

SCREEN C: When optional output transformer is used, various output voltages are indicated as such.

Line 1	OUTPUT VOLTAGE	120 V
Line 2	OUTPUT VOLTAGE	N/A
Line 3	OUTPUT VOLTAGE	240 V
Line 4	OUTPUT VOLTAGE	N/A

OnLine Power

2. INPUT OK @ CHG ON

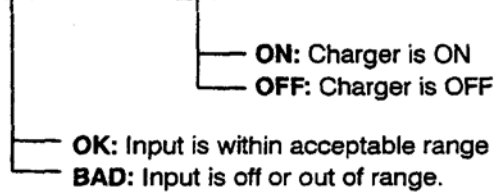

3. BATTERY OK @ DC OK

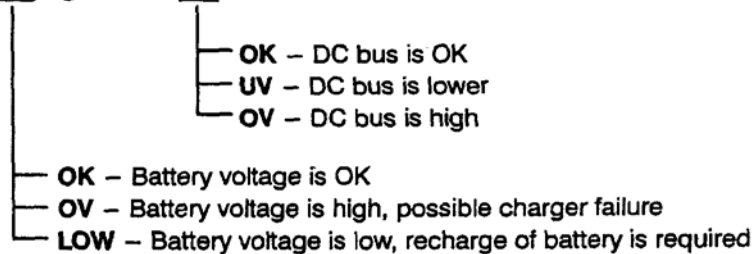

4. ON INVERTER @ OUT OK

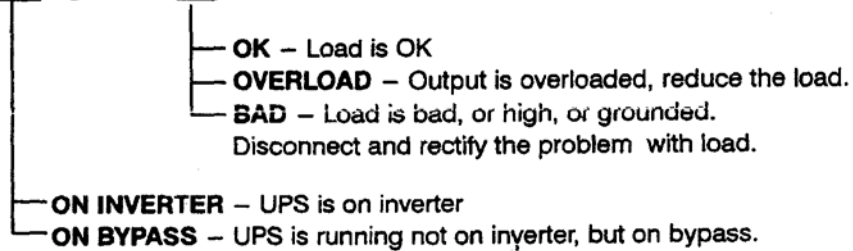

APPENDIX D: SPECIFICATION

POWER RATING (KW)	3.0	5.0	7.5	10	12.5	15	
VOLTAGE (VAC) INPUT	Single Phase, 120/208/240		Single Phase, 240/208VAC				
MAXIMUM CURRENT	40/19/16	58/30/28	41/36	58/50	69/60	83/72	
TOLERANCE	+10% to -15%						
FREQUENCY (Hz)	60 +/- 3%						
POWER FACTOR	0.98 to 1.0 (Typical)						
OVERCURRENT PROTECTION	Electronic / Circuit Breaker						
NUMBER OF WIRES	2 Wires plus Ground						
POWER CONNECTION	Hard Wired (Terminal Block)						
OUTPUT							
RATING (KVA/KW)	3.0	5.0	7.5	10	12.5	15	
VOLTAGE (VAC)	120/120/240	120/120/240	120/240	120/240	120/240	120/240	
VOLTAGE REGULATION	+/-3% No Load to Full Load; +/-3% High Line to Low Line						
FREQUENCY (Hz)	60 Hz +/-0.25 Hz (When on Inverter)						
WAVESHAPE	Sine Wave						
HARMONIC DISTORTION	<5% THD; <3% Single Harmonic						
CREST FACTOR	Up to 3 to 1						
POWER FACTOR	1.0PF						
STEADY-STATE CURRENT	25/12.5	42/20.8	62.5/31.3	83.3/41.7	104/52	125/62.5	
OVERLOAD	125 % for One (1) minutes, surge 150 %						
PROTECTION	Electronic / Circuit Breaker						
NOISE REJECTION	-120 kB Common Mode; -60 kB Normal Mode						
NUMBER OF WIRES	2 Wires plus Ground						
POWER CONNECTION	Hard Wired (Terminal Block)						

OnLine Power

POWER RATING (KVA/KW)	3.0	5.0	7.5	10	12.5	15
BATTERY						
BATTERY RUN TIME	See Appendix C for various Run time					
BATTERY TYPE	Sealed, Maintenance-Free, AGM, VRLA type					
NOMINAL DC VOLTAGE	96 VDC	120 VDC	120 VDC	192 VDC	192 VDC	240 VDC
OVERCURRENT PROTECTION	Circuit Breaker					
PACKAGING	Batteries Housed in Same Enclosure and/or additional battery cabinet (See Table 2-1)					
MONITORING AND COMMUNICATIONS						
LCD SCREEN	Input Voltage, Batt. Charger, UPS Output; On Batt.; Low Batt.; Summary Alarm					
INDICATORS	LCD Display Panel					
RELAY INTERFACE	Dry Contacts for: UPS On (N.C.); On Inverter (N.O.); Loss of Input Power (N.O.); Low Battery (N.O.)					
CONTACT RATING	125 Volts (AC or DC) Maximum; 1.25 Amperes Maximum; 30 Watts / 50 VA Maximum					
INTERFACE CONNECTION	Hard Wired (Terminal Block)					
ENVIRONMENTAL						
USRGE WITHSTANDABILITY	ANSI C62.41-1980 Categories A & B					
OPERATING TEMPERATURE	Meets NEMA Requirements					
OPERATING RELATIVE HUMIDITY	0 to 95% Non-Condensing					
ALTITUDE	Up to 6,000 Feet (1,829 Meters) with No De-Rating					
COOLING	Air Cooled-Forced Fan					
PHYSICAL						
SIZE WxHxD in. (cm)	18 x 35 x 32 (45.7 x 88.9 x 84.3 cm)					
WEIGHT lbs (kg) with batteries	600(273)	900(409)	1150(523)	1600(727)	1850(841)	2250(1023)
CONSTRUCTION	Painted Steel Enclosure with 3 Point Double Locking Front Door; and Full-Length Door Hinge.					
ENCLOSURE	Designed for Inside Installations					
COLOR	Natural finish					
ACCESSIBILITY	Front - All Servicing is Through the Front; No Side or Rear Access is Required.					
CABLE ENTRY	Bottom or sides					
MOUNTING	Four (4) Holes Provided to Anchor Enclosure to Pedestal (Supplied by Others)					

OnLine Power

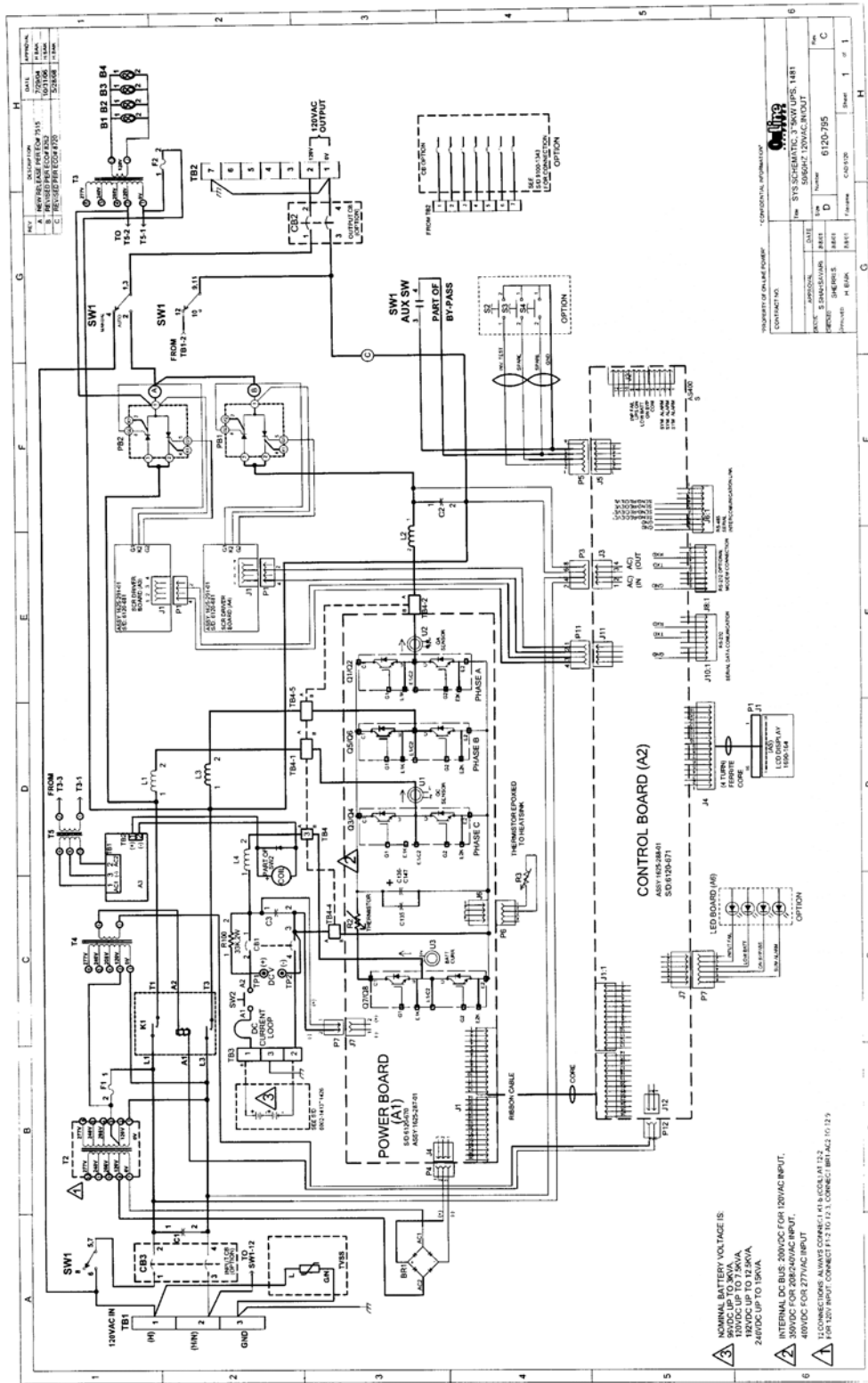

REV. 1	DATE	APPROVAL
2	REVISED FOR PERIOD 1515	OPTION
3	REVISED FOR PERIOD 1515	OPTION
4	REVISED FOR PERIOD 1515	OPTION
5	REVISED FOR PERIOD 1515	OPTION
6	REVISED FOR PERIOD 1515	OPTION

PROJECT NO.	CONTRACT NO.	PROJECT NAME
6120-795		6120-795
DATE	REVISED	BY
DESIGNED BY	CHECKED BY	DATE
DRAWN BY	SCALE	1/8" = 1"
APPROVED BY	DATE	

INTERNAL DC BUS 200VDC FOR 120VAC INPUT.
 400VDC FOR 208/240VAC INPUT.
 480VDC FOR 277VAC INPUT.
 1000VDC FOR 347VAC INPUT.
 FOR 208V INPUT CONNECT P1 TO P2. FOR 240V INPUT CONNECT P1 TO P3. FOR 277V INPUT CONNECT P1 TO P4. FOR 347V INPUT CONNECT P1 TO P5.

OnLine Power

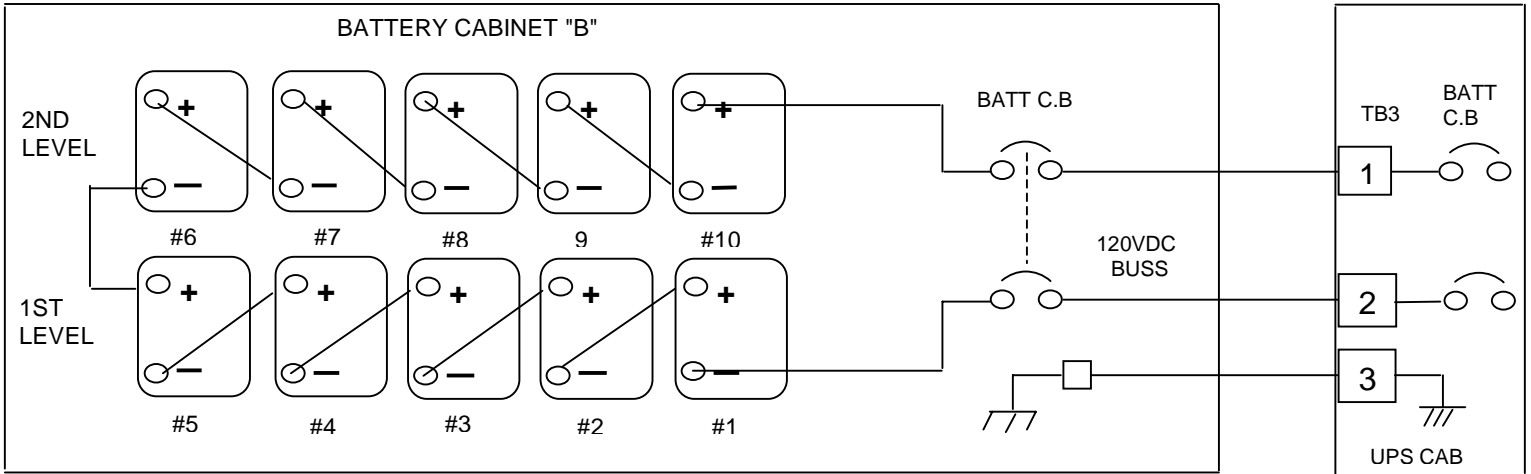

"B" CABINET BATTERY (QTY:10) SYSTEM

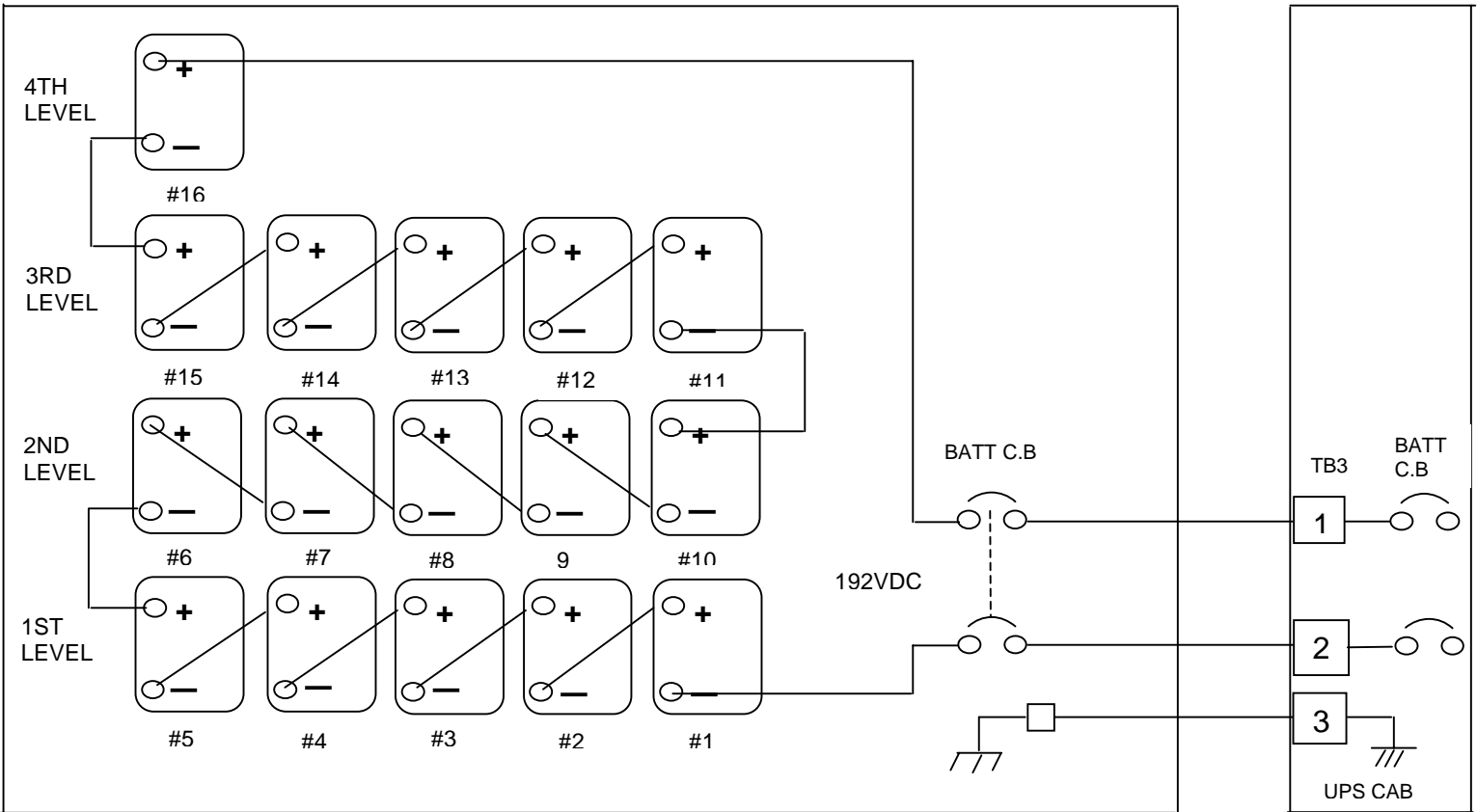

"B" OR "C" BATTERY (QTY 16) SYSTEM

OnLine Power

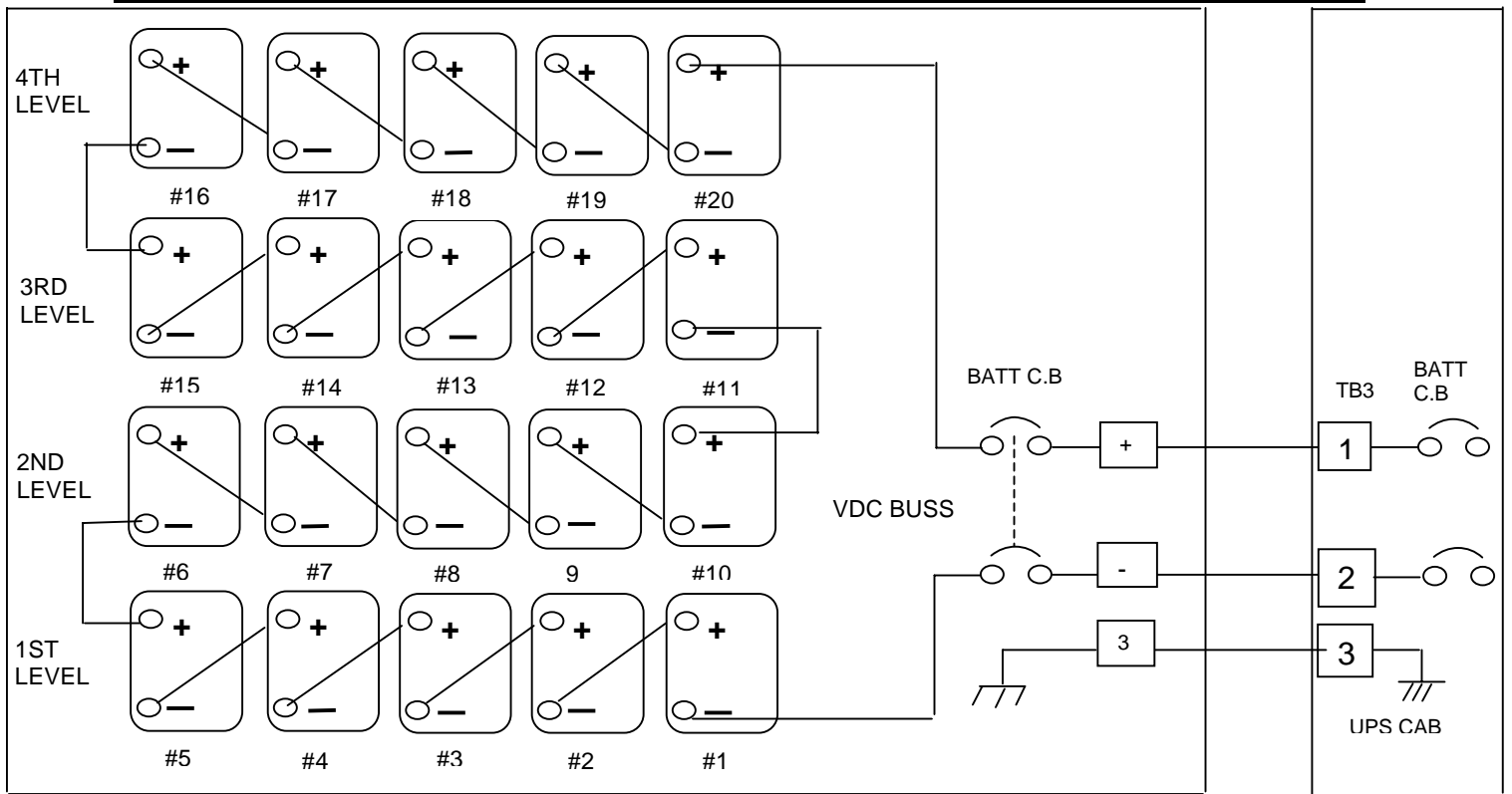

"C" CABINET BATTERY (QTY:20) SYSTEM

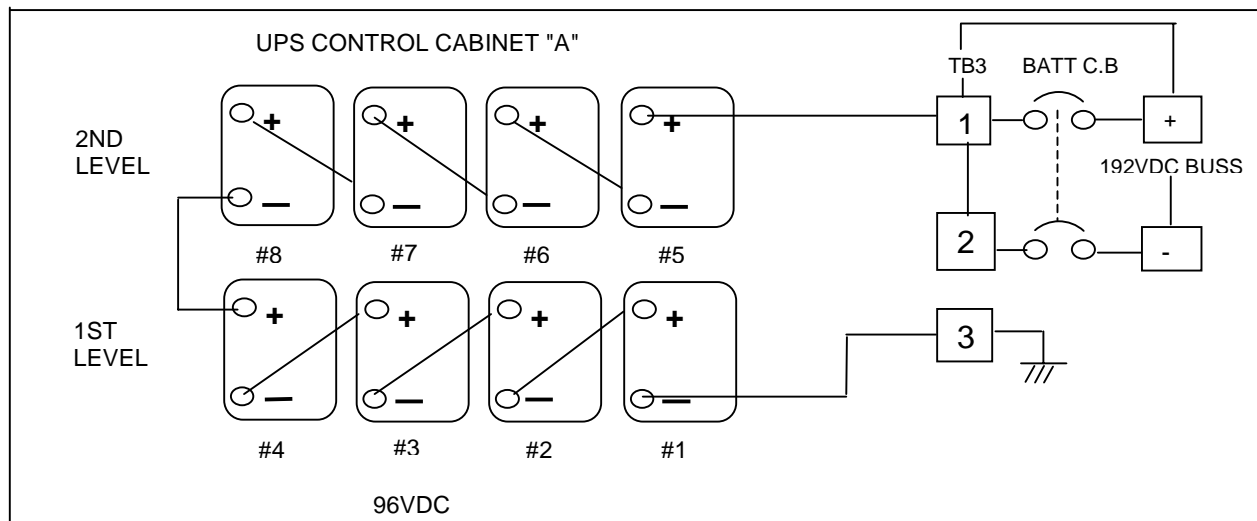

3KW/5KW (8X35AH) BATTERY SYSTEM ONLY

OnLine Power

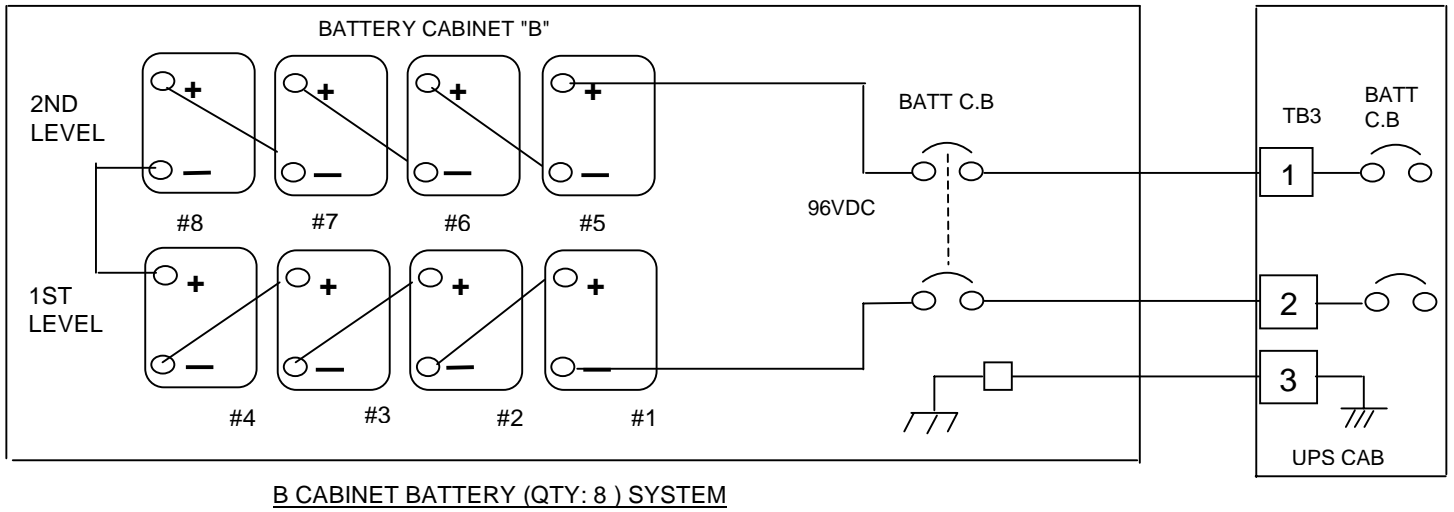

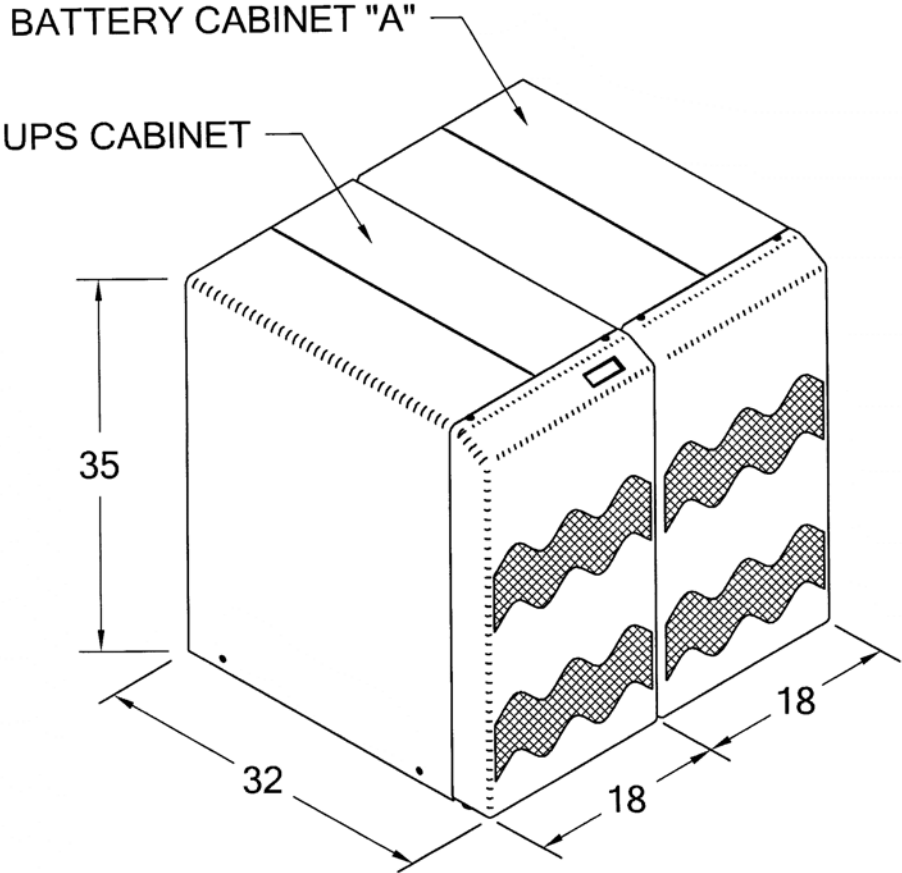

CABINETS BASIC ARRANGEMENT

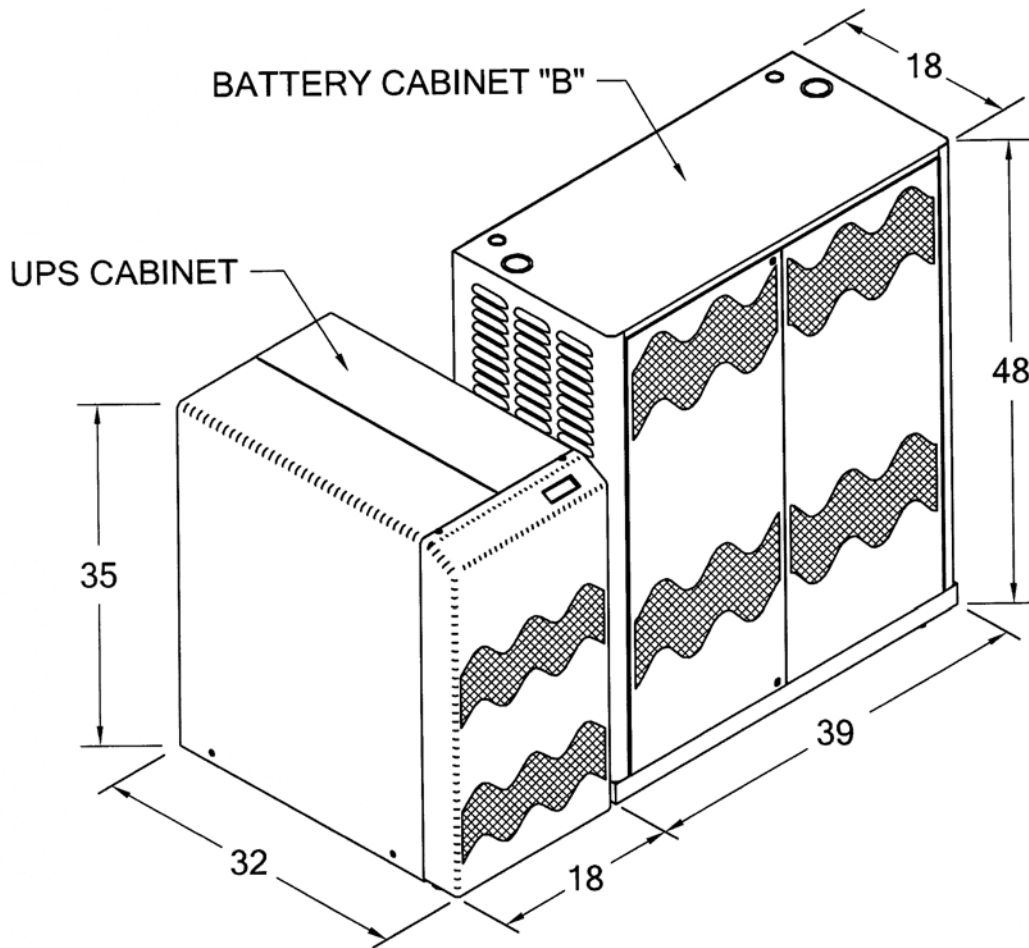

CABINETS BASIC ARRANGEMENT

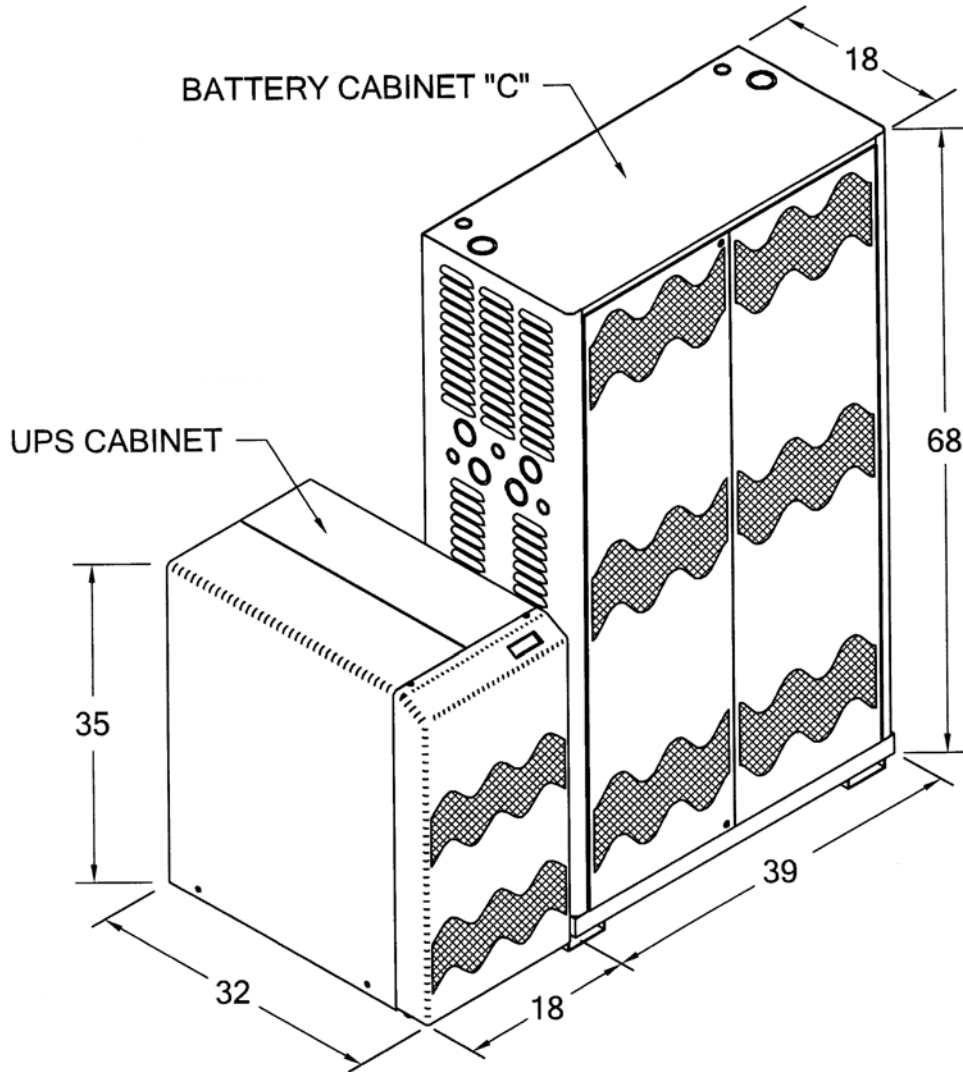

CABINETS BASIC ARRANGEMENT

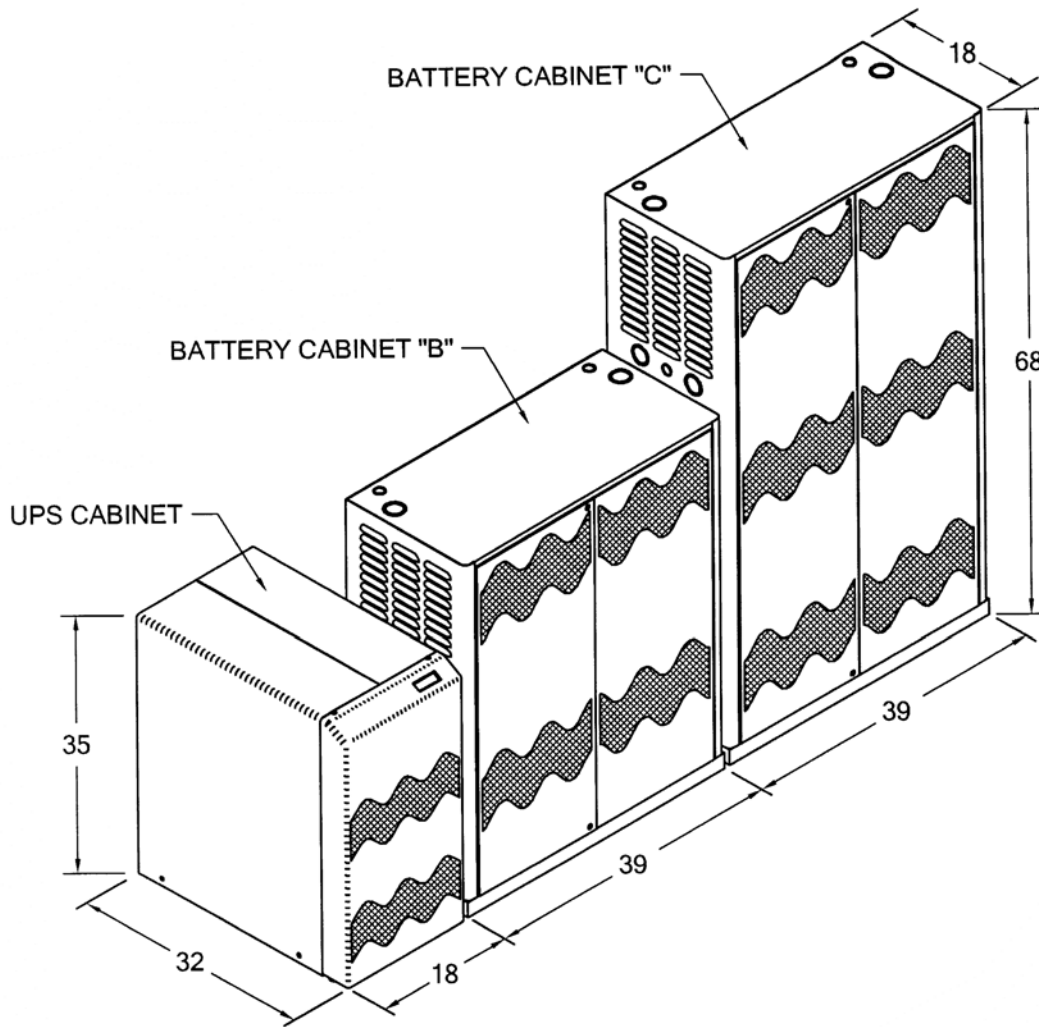

CABINETS BASIC ARRANGEMENT

BATTERY CABINET

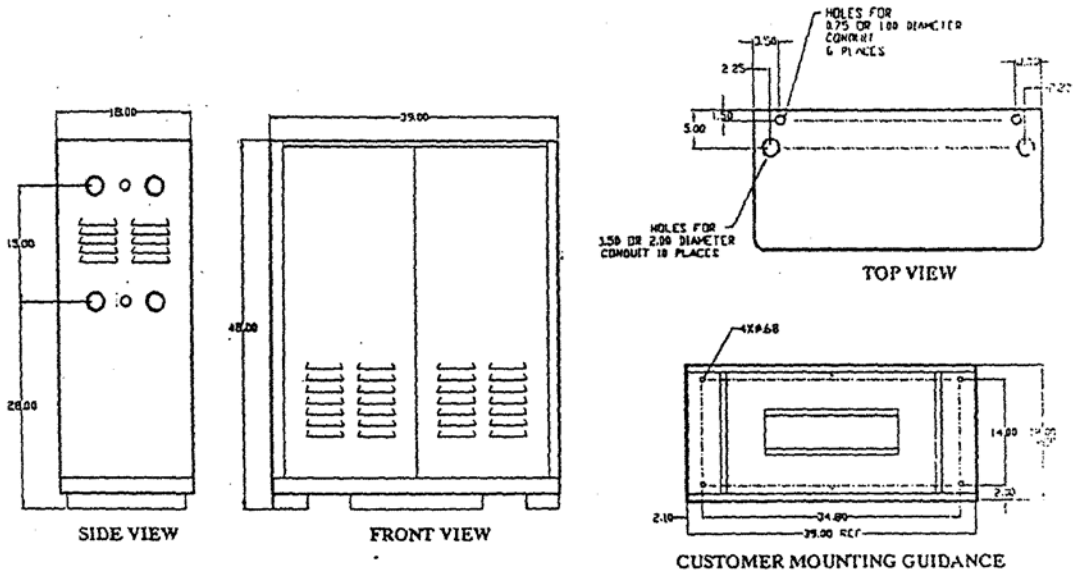

48" CABINET CABLE ACCESS

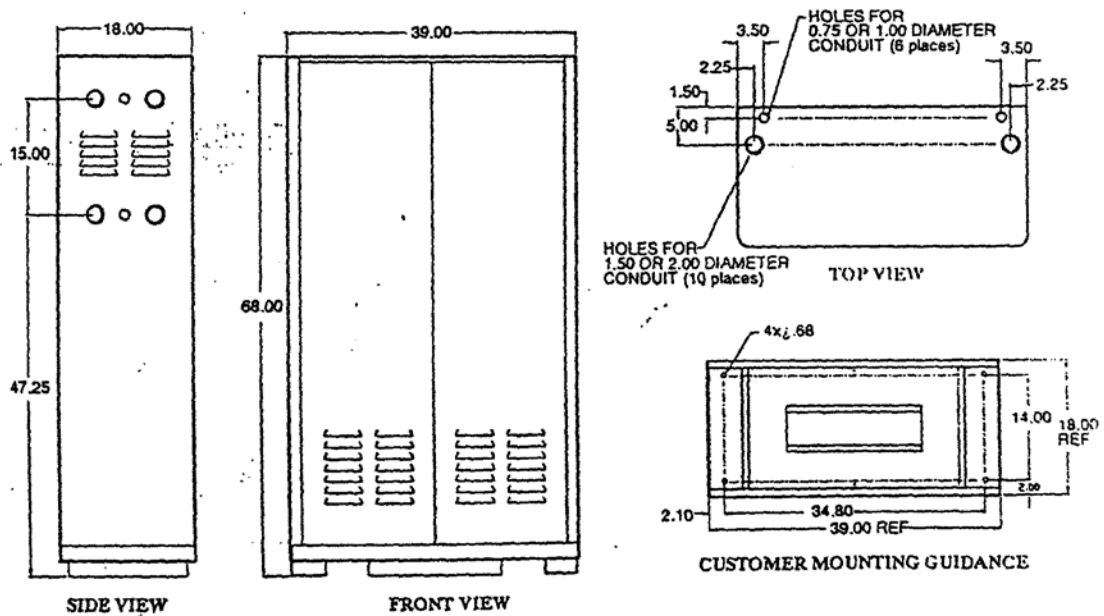

66" CABINET CABLE ACCESS

OnLine Power

Free Manuals Download Website

<http://myh66.com>

<http://usermanuals.us>

<http://www.somanuals.com>

<http://www.4manuals.cc>

<http://www.manual-lib.com>

<http://www.404manual.com>

<http://www.luxmanual.com>

<http://aubethermostatmanual.com>

Golf course search by state

<http://golfingnear.com>

Email search by domain

<http://emailbydomain.com>

Auto manuals search

<http://auto.somanuals.com>

TV manuals search

<http://tv.somanuals.com>