

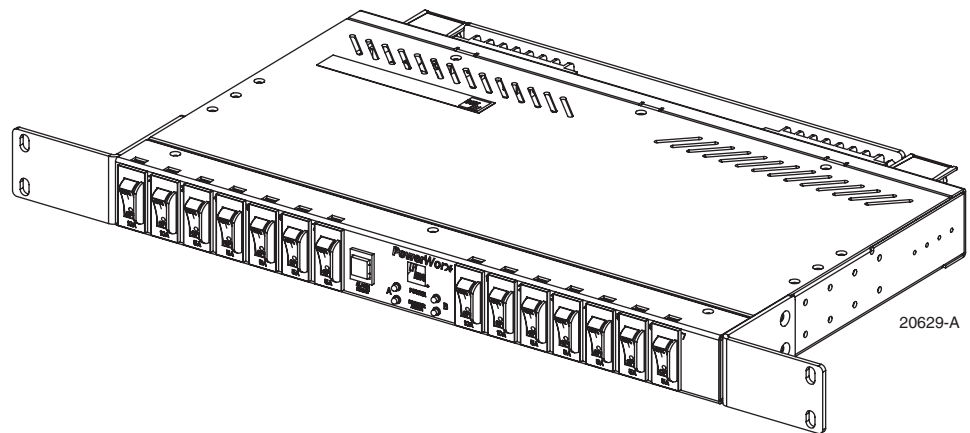

PowerWorx[®] Power Distribution Products Circuit Breaker Panel With Reset Switch User Manual



COPYRIGHT

© 2006, ADC Telecommunications, Inc.
All Rights Reserved
Printed in the U.S.A.

REVISION HISTORY

ISSUE	DATE	REASON FOR CHANGE
1	8/2005	Original.
2	3/2006	Wire colors corrected on Page 28.

TRADEMARK INFORMATION

ADC and PowerWorx are registered trademarks of ADC Telecommunications, Inc.

DISCLAIMER OF LIABILITY

Contents herein are current as of the date of publication. ADC reserves the right to change the contents without prior notice. **In no event shall ADC be liable for any damages resulting from loss of data, loss of use, or loss of profits and ADC further disclaims any and all liability for indirect, incidental, special, consequential or other similar damages. This disclaimer of liability applies to all products, publications and services during and after the warranty period.**

This publication may be verified at any time by contacting ADC's Technical Assistance Center at 1-800-366-3891, extension 73475 (in U.S.A. or Canada) or 952-917-3475 (outside U.S.A. and Canada), or by e-mail to connectivity_tac@adc.com.



ADC Telecommunications, Inc.
P.O. Box 1101, Minneapolis, Minnesota 55440-1101
In U.S.A. and Canada: 1-800-366-3891
Outside U.S.A. and Canada: (952) 938-8080
Fax: (952) 917-1717

TABLE OF CONTENTS

Content	Page
About This Manual	v
Standard Certification	v
Admonishments	v
General Safety Precautions	v
List of Acronyms	vi
1 PRODUCT DESCRIPTION	1
1.1 Product Functions and Features	1
1.2 Panel Components	1
1.3 Packaged Hardware	3
1.4 Power Buses	4
1.5 Input Voltage	5
1.6 Input Connectors	5
1.7 Output Voltage	5
1.8 Output Connectors	5
1.9 Chassis Ground Connections	6
1.10 Circuit Breakers	6
1.11 Power-on Indicators	6
1.12 Breaker Alarm Indicators	7
1.13 Alarm Operation	7
1.14 Alarm Connections	7
1.15 Reset Switch	7
1.16 Circuit Breaker Designation Card and Holder	7
1.17 Voltage Designation Label	8
1.18 Material and Finish	8
1.19 Cooling	8
1.20 Protective Covers	9
1.21 Mounting	9
1.22 Specifications	10
1.23 Dimensions	11
2 ACCESSORIES	12
3 UNPACKING AND INSPECTION	12
4 INSTALLATION	12
4.1 Installation Tools Required	13
4.2 Materials Required	13
4.3 Pre-Installation Testing	13
4.4 Cable Management Bar (Optional Accessory)	16
4.5 Mounting Panel on Rack	16
4.6 Installing Designation Cards	18
4.7 Installing Voltage Designation Label	18
4.8 Installing Ground Wires	18
4.9 Connecting Alarms	19

TABLE OF CONTENTS

Content	Page
4.10 Connecting Output	20
4.11 Connecting Input	21
4.12 Installing Protective Covers	23
5 TESTING	24
5.1 Testing Power Indicators and Connection Polarity	24
5.2 Testing Alarm Contacts Normal State	24
6 OPERATION	25
6.1 Connecting New Equipment	25
6.2 Using the Reset Switch	26
7 MAINTENANCE	26
7.1 Performing a Routine Inspection	26
7.2 Replacing a Circuit Breaker	26
8 CUSTOMER INFORMATION AND ASSISTANCE	29
A ALLOWABLE AMPACITIES OF INSULATED CONDUCTORS	31

ABOUT THIS MANUAL

This manual describes the PowerWorx Circuit Breaker Panel With Reset Switch, and provides all information required to install, test, and operate this product.

STANDARD CERTIFICATION

The panel conforms to the applicable requirements of the following: UL/CSA/EN 60950, FCC Part 15, CISPR 22, and CISPR 24.

ADMONISHMENTS

Important safety admonishments are used throughout this manual to warn of possible hazards to persons or equipment. An admonishment identifies a possible hazard and then explains what may happen if the hazard is not avoided. The admonishments — in the form of Dangers, Warnings, and Cautions — must be followed at all times. These warnings are flagged by use of the triangular alert icon (seen below), and are listed in descending order of severity of injury or damage and likelihood of occurrence.



Danger: *Danger is used to indicate the presence of a hazard that **will** cause severe personal injury, death, or substantial property damage if the hazard is not avoided.*



Warning: *Warning is used to indicate the presence of a hazard that **can** cause severe personal injury, death, or substantial property damage if the hazard is not avoided.*



Caution: *Caution is used to indicate the presence of a hazard that **will** or **can** cause minor personal injury or property damage if the hazard is not avoided.*

GENERAL SAFETY PRECAUTIONS



Warning: *The circuit breaker panel uses electrical voltage and current levels that may be considered an energy hazard. Only qualified personnel should be allowed to install, operate, maintain, or otherwise come into contact with this equipment when energized. Only insulated tools should be used on energized elements of the panel.*



Warning: *Disconnect or turn off the power before connecting the input or output wires on the circuit breaker panel. This may require turning off the system office battery input at the battery distribution fuse bay or turning off the circuit breakers at the panel.*



Warning: *Wet conditions increase the potential for receiving an electrical shock when installing or using electrically-powered equipment. To prevent electrical shock, never install or use electrical equipment in a wet location or during a lightning storm.*



Warning: *To prevent the system from overheating, do not operate it in an area that exceeds the maximum recommended ambient temperature of 55° C.*



Warning: *Stability hazard. The rack stabilizing mechanism must be in place, or the rack must be bolted to the floor before you slide the unit out for servicing. Failure to stabilize the rack can cause the rack to tip over.*



Warning: *Suitable for mounting on concrete or other non-combustible surface only.*



Warning: *Take care when connecting units to the supply circuit so that wiring is not overloaded.*

LIST OF ACRONYMS

LED -- Light-Emitting Diode

1 PRODUCT DESCRIPTION

This section describes the PowerWorx Circuit Breaker Panel With Reset Switch. Topics include product functions and features, panel components, packaged hardware, power buses, input voltage, input connectors, output voltage, output connectors, chassis ground connections, circuit breakers, power on indicators, breaker alarm indicators, alarm operation, alarm connections, reset switch, circuit breaker designation card and holder, voltage designation label, material and finish, cooling, protective covers, mounting, specifications, and dimensions.

1.1 Product Functions and Features

The Circuit Breaker Panel With Reset Switch supplies low-voltage, protected dc power to –24 Vdc or –48 Vdc powered equipment installed in a central office, multimedia headend, remote site, or other restricted access location. The panel provides the following functions and features:

- Two side-by-side power buses, designated A and B, each with seven power outputs.
- Fourteen circuit breakers (seven per bus). Each bus has two 10 Amp circuit breakers and five 5 Amp circuit breakers.
- Maximum input rating of 45 Amps per bus. This corresponds to a maximum input rating of 90 Amps for the total panel.
- One Power On LED (green) and one Breaker Alarm LED (red) for each bus.
- One Reset switch for the total panel. The Reset switch allows the operator to reset the panel to a non-alarming state if a breaker has been turned off or tripped due to an overcurrent condition.
- Alarm contacts (screw-down barrier terminal strips) for remote reporting of an alarm condition. The alarm contacts can be used to open or close a loop connected to an external alarm system.
- Mounting brackets providing the ability to mount the panel in a 19-inch (482.6 mm) or 23-inch (584.2 mm) WECCO or EIA equipment rack. The panel occupies one rack space (1.75 inches, 44.4 mm).

► **Note:** The panel requires one open rack space above the chassis and one open rack space below the chassis for heat dissipation.

- Two-hole compression-lug style terminals for input power connections.
- Screw-down barrier terminal strips for output power connections.
- Two chassis ground studs.
- Easy to remove rear protective covers. These covers mount over the input and output power connections to prevent inadvertent contact.

1.2 Panel Components

Figure 1 shows the components of the circuit breaker panel.

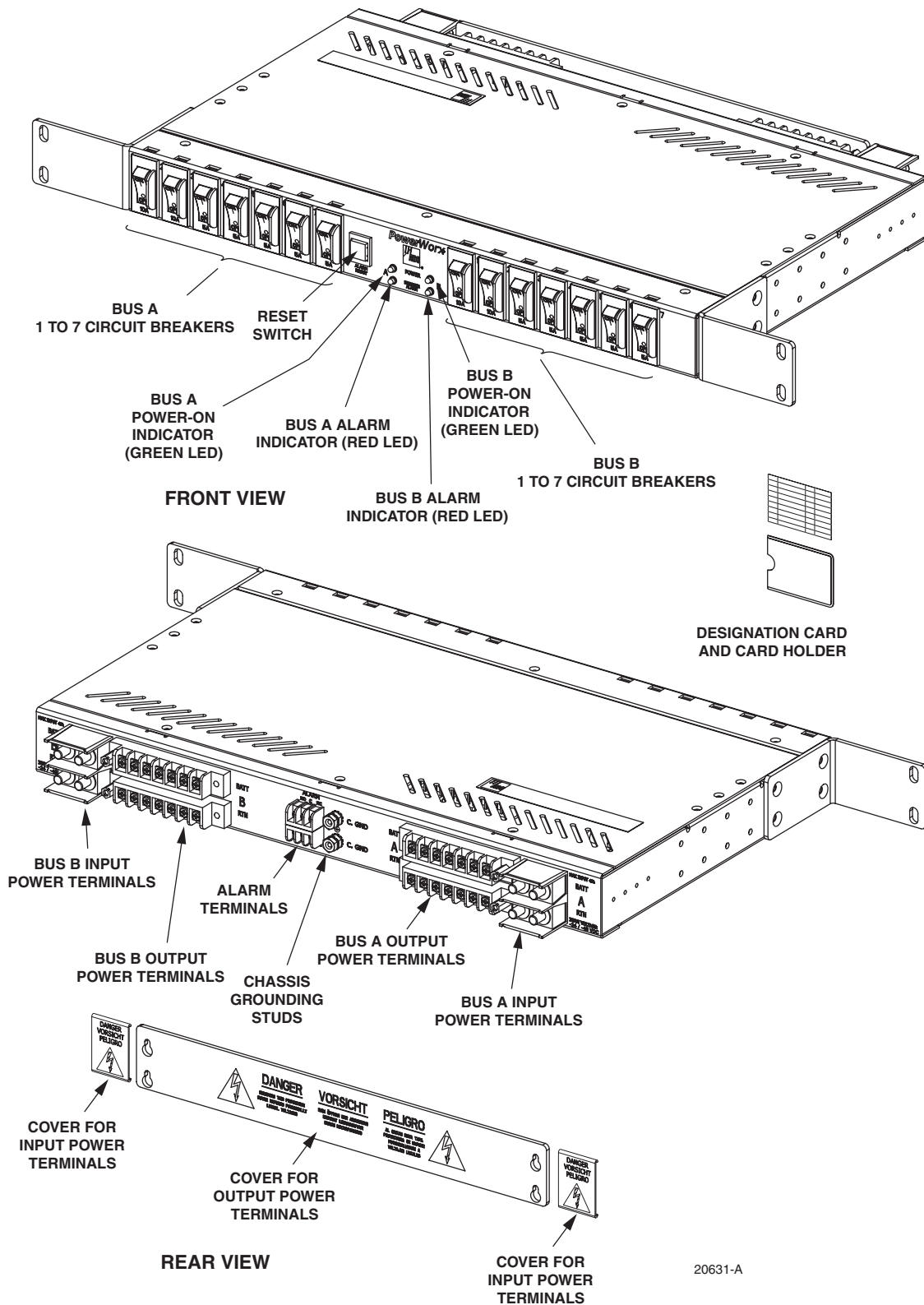

Figure 1. Circuit Breaker Panel Components

1.3 Packaged Hardware

The shipped product includes hardware components that are packaged separately and shipped in the carton with the basic panel. **Figure 2** shows the shipped items:

- 5/16-inch long, Phillips drive, 8-32 flat-head screws (8)—Used to secure the mounting brackets to the panel.
- 3/8-inch long, combination drive, 12-24 pan-head screws (4) and #12 flat washers (4)—Used to secure the panel mounting brackets to the equipment rack.
- #10 ring terminals (2) for #12–#10 AWG wire—Can be used to connect the grounding cables to the grounding studs.
- 2-Hole Lugs for #6 AWG wire (4)—Used to connect input power cable to input power terminal blocks.

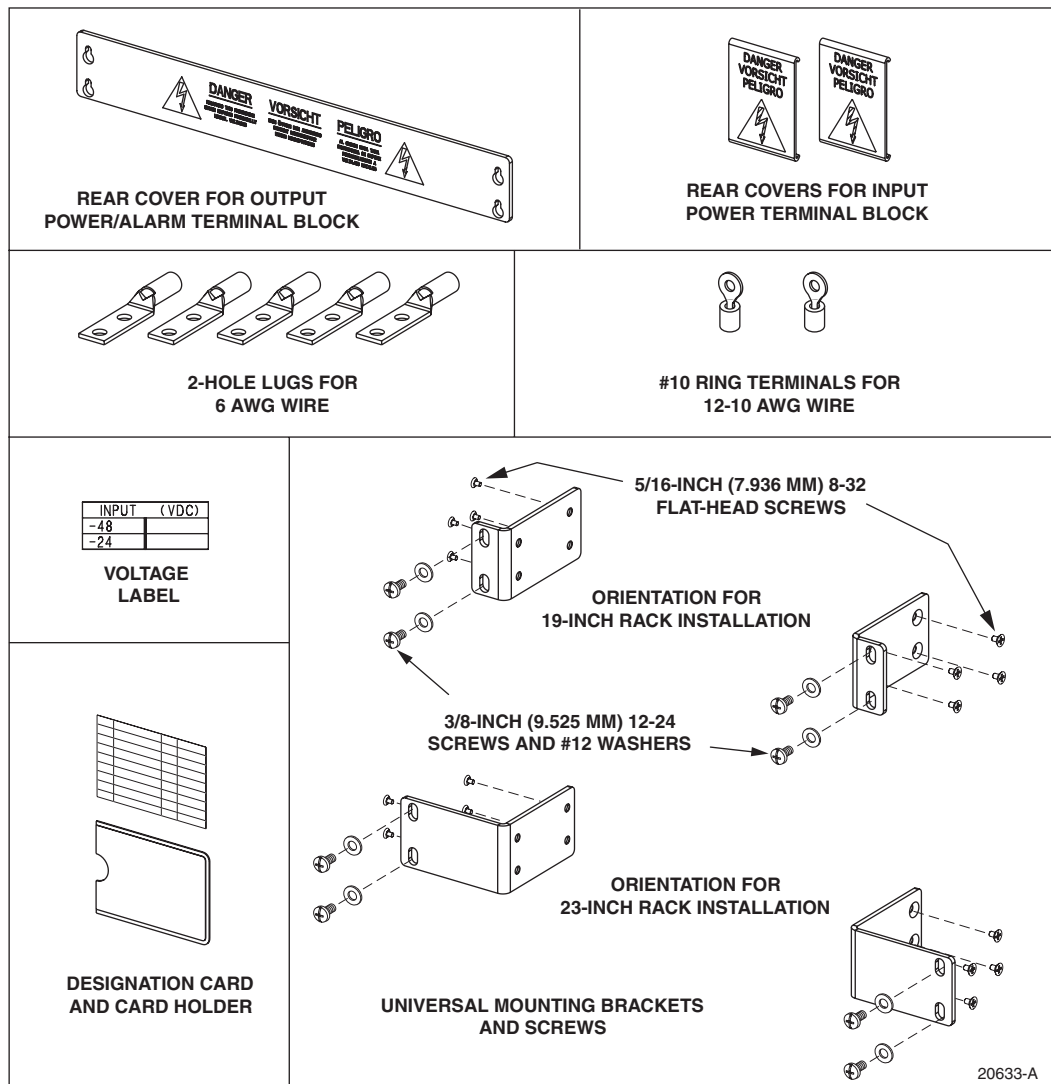

Figure 2. Packaged Hardware

- Rear protective input terminal covers (2) and output/alarm terminal cover (1)—Used to prevent accidental contact with the alarm and power terminals.
- #6-32 Screws (4)—Used to fasten output/alarm terminal cover to rear of panel chassis.
- Designation card and card holder (1)—Used to record information about the protected equipment. Cards and clear cover insert into the card holder.
- Voltage label (1)—Used to indicate whether the input voltage is -48 or -24 Vdc.

1.4 Power Buses

Each circuit breaker panel has two isolated power buses. Each bus distributes the input power to the output power circuits. In each bus circuit, current flows from the input power bus, through the circuit breaker, to the output power circuit. The current capacity of each bus is 45 Amps maximum. Figure 3 is a block diagram of the power buses.

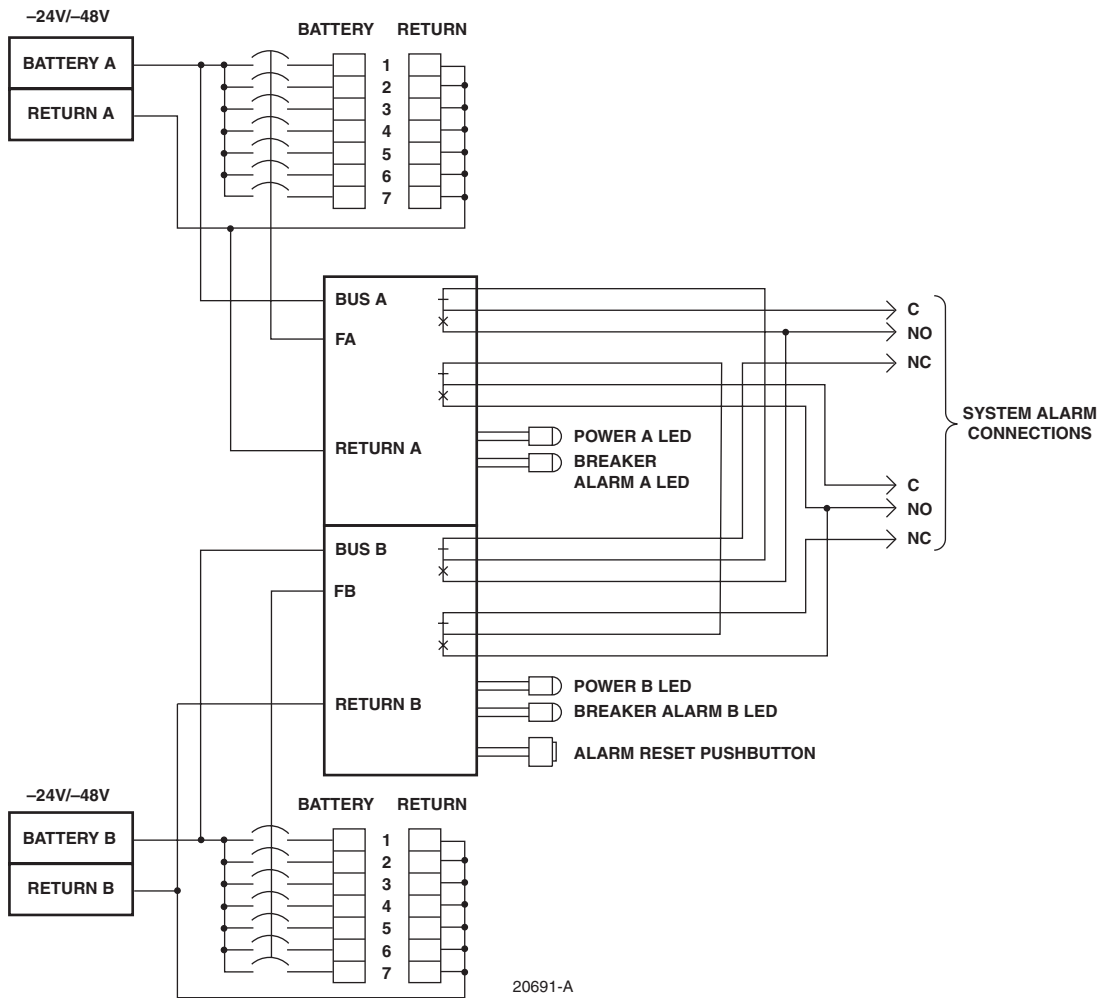

Figure 3. Circuit Breaker Panel Block Diagram

Each of the power buses supports seven circuit breaker positions including two 10 Amp circuit breaker positions and five 5 Amp circuit breaker positions giving a total capacity per bus of 45 Amps.

When a circuit breaker trips, the input power bus is disconnected from the corresponding output circuit.

1.5 Input Voltage

The dual bus circuit breaker panel can accommodate either -24 Vdc on both buses or -48 Vdc on both buses.



Warning: *Use of one bus only on a dual bus panel will result in false alarms for the unused bus. Power is required on both buses on a dual bus panel for normal operation.*

The voltage level is sensed by the circuit breaker panel circuitry. The input voltages used with the circuit breaker panel can fall within the following ranges:

- -24 Vdc nominal, within range of -21 Vdc to -30 Vdc
- -48 Vdc nominal, within range of -42 Vdc to -56 Vdc

1.6 Input Connectors

Each power bus has two input connectors on the rear of the circuit breaker panel through which input power is provided. The two input power connectors are labeled “BATT” (battery) and “RTN” (return). Each input connector consists of a pair of 0.25-inch (0.635 cm) studs (with nuts) mounted on a plastic terminal block. Each pair of studs can accept different size 2-hole compression lugs used with a range of wire sizes up to #6 AWG copper wire. Two 2-hole lugs per bus for use with #6 AWG wire (four total) are provided with the circuit breaker panel. Additional lugs are available as accessory items. Maximum lug width is 0.62 inches (1.6 cm). In selecting the copper wire size to be used for power input, consider the allowable ampacity as defined by local practice and the National Electrical Code (refer to [Appendix A](#)).

1.7 Output Voltage

The output voltage will be the same as the applied input voltage.

1.8 Output Connectors

Each bus has two screw-down terminal strips with seven 8-32 screws each on the back of the panel. The upper terminal strip contains the BATT (power feed) connectors. The lower terminal strip contains the RTN (return) connectors. When a piece of equipment is connected to the circuit breaker panel, it is connected to one BATT connector and one RTN connector located vertically above and below one another.

The individual terminals are on 0.375 inch (9.525 mm) centers with a distance between barriers of 0.32 inch (81.3 mm). The terminals can accept a variety of wire sizes up to #12 AWG with crimp-on spade lug connectors or wires in sizes from #12 AWG to #22 AWG with the insulation stripped back. The connectors or wires are inserted under the screws in the terminal strip, and the screws are tightened down.

In selecting the copper wire size to be used for power output, consider the allowable ampacity as defined by local practice and the National Electrical Code (refer to [Appendix A](#)).

1.9 Chassis Ground Connections

Two #10 studs (with nuts) are provided for grounding the circuit breaker panel chassis. The studs are mounted on 0.625 inch (15.875 mm) centers, and can accommodate a 2-hole compression lug. Two crimp ring lug terminals for use with two #10 AWG wires are provided with the circuit breaker panel.

1.10 Circuit Breakers

The circuit breakers are magnetic actuation, manual reset, single pole, replaceable, 60 Vdc rated circuit breakers, with finger guard and amperage markings. Each power bus has two 10 Amp breakers and five 5 Amp breakers. The maximum capacity per bus is 45 Amps.

The circuit breakers are of the type called “short delay.” The trip times of short delay circuit breakers are a function of the percent of rated current, as indicated in [Table 1](#). The circuit breaker will trip (open) and the switch will move to the off position (bottom pushed in) when the circuit current exceeds the capacity of the circuit breaker. To reset a circuit breaker, push the switch to the on position (top pushed in).

Circuit breakers are field-replaceable. Please contact ADC Technical Support if replacement is required (refer to [Section 8, Customer Information and Assistance, on page 29](#)).

Table 1. Short Delay Trip Times in Seconds

PERCENT OF RATED CURRENT								
100%	135%	150%	200%	400%	600%	800%	1000%	1200%
NO TRIP	.300-7.00	.200-5.00	.100-2.00	.030-.500	.008-.300	.006-.150	.005-.100	.005-.100

1.11 Power-on Indicators

A green LED Power On indicator for each power bus is mounted on the front panel of the circuit breaker panel. If the LED indicator is on, power is being applied to the bus input connectors. If the green LED indicator is off, power is not being applied to the bus input connectors.

1.12 Breaker Alarm Indicators

For each bus, the circuit breaker panel has one visual Breaker Alarm indicator (red LED) mounted on the front of the panel. The breaker alarm indicator lights if any circuit breaker on the corresponding bus trips off. Loss of power to either bus will cause the circuit breaker alarm indicator for the corresponding bus to be off.

1.13 Alarm Operation



Warning: *Use of one bus only on a dual bus panel will result in false alarms for the unused bus. Power is required on both buses on a dual bus panel for normal operation.*

Each bus contains circuitry that operates a set of Form C alarm relay contacts when any circuit breaker on the bus trips off or when input power to the bus is lost. The alarm contacts may be used to open or close a loop connected to an external alarm system.

Alarm connections are provided through a screw-down barrier terminal strip located on the rear side of the panel. During normal operation, the normally open (NO) contacts remain open and the normally closed (NC) contacts remain closed. When a circuit breaker trips or power is lost, the NO contacts close creating a connection from NO to common (C), and the NC contacts open creating an open circuit between the NC and C contacts. When the Reset button is tripped, these contacts return to a normal operational state.

The maximum current rating for each set of alarm relay contacts is 1.0 Amp.

1.14 Alarm Connections

The panel has a screw-down barrier terminal strip for the alarm relay contact connections. The screw-down terminal strip consists of two single row terminal blocks, each with three 3-48 screw terminals. The screw terminals are mounted on 0.250 inch (6.350 mm) centers with a maximum distance between barriers (maximum connecting terminal width) of 0.200 inch (5.080 mm). The three terminals in each row are labeled NO, C, and NC. The terminals will accept #16 to #30 AWG copper wire with insulation stripped back.

1.15 Reset Switch

The Reset switch, when tripped, stops the reporting of any current alarms due to circuit breakers being in the off position. In this state, only new alarms are reported.

1.16 Circuit Breaker Designation Card and Holder

A circuit breaker designation card as shown in [Figure 4](#) and a card holder are provided with the circuit breaker panel. The card holder is intended to be attached either to one of the panel mounting brackets, to a part of the rack in which the panel is installed, at a location close to the panel, or to the underside of the panel, as desired.

The card should be filled out with circuit information for each of the circuit breakers installed in the panel and inserted in the card holder. The card holder has a pressure sensitive adhesive backing for attachment.

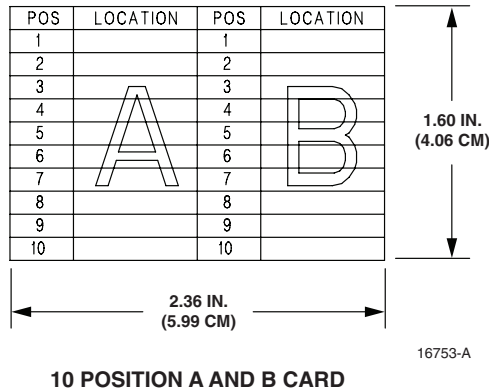

Figure 4. Circuit Breaker Designation Card

1.17 Voltage Designation Label

A voltage designation label such as shown in Figure 5 is provided with the circuit breaker panel. The label is intended to be filled out with the actual voltage present on the buses and placed on the panel. The voltage designation label has a pressure sensitive adhesive backing for attachment.

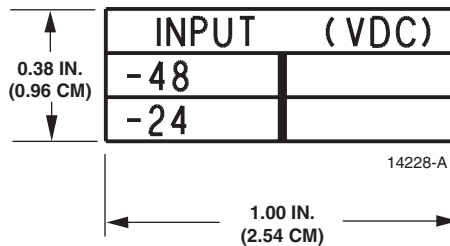

Figure 5. Voltage Designation Label

1.18 Material and Finish

The panel chassis and brackets are made of 16-gauge cold rolled steel. The panel and brackets are finished with a putty-color powder coat.

1.19 Cooling

The circuit breaker panel is ventilated to allow efficient convection cooling of all components without the use of fans or blowers. Holes are provided in the top and bottom of the panel to allow heated air to escape from the panel and cool air to enter.

- ▶ **Note:** The panel requires one open rack space above the chassis and one open rack space below the chassis for heat dissipation.

1.20 Protective Covers

The panel has three protective covers mounted on the rear side of the panel. Two of these are snap-on covers that mount over the input power connectors. A third, larger cover mounts over the output power connectors and the external alarm connections. This cover is secured with four 6-32 screws provided with the panel. Access to these connectors and terminals is obtained by removing the appropriate cover. The covers over the input power terminals are removed by unsnapping them from their position. The larger cover is removed by loosening (but not removing) the four screws. The holes in the large cover are keyed to allow it to be pulled to the side and lifted clear of the screws.

1.21 Mounting

The circuit breaker panel can be mounted in a 19- or 23-inch rack (48.26 or 58.42 cm) using the mounting brackets shown in [Figure 2 on page 3](#). The panel can be flush mounted or recessed 1, 2, 3, or 4 inches (25.4, 50.8, 76.2, or 101.6 mm) from the front of the rack. The mounting holes are slotted to permit installation in racks with WECO 1.00-inch (2.54 cm) hole spacing or EIA 1.25-inch (3.18 cm) hole spacing.

The following mounting brackets and screws are enclosed with the circuit breaker panel:

- Two brackets for 19-inch rack installations;
- Two brackets for 23-inch rack installations;
- Eight 5/16-inch (7.936 mm) long, 8-32 chromate finish, thread-forming, flathead screws for attaching the brackets to the circuit breaker panel;
- Four 3/8-inch (9.525 mm) long, 12-24 thread-forming screws and washers for attaching the brackets to the rack.



Caution: Use only the 5/16-inch (7.936 mm) long, chromate finish, flathead, thread forming screws for attaching the mounting brackets to the circuit breaker panel. Use of any other hardware could cause contact with internal parts of the panel. If parts are missing, please contact ADC.

The slotted mounting hole pattern in the mounting brackets compensates for vertical rack differences and allows mounting the circuit breaker panel in either 1.75- or 2-inch (4.45 or 5.08 cm) rack spaces.

1.22 Specifications

Table 2 lists specifications for the circuit breaker panel.

Table 2. Circuit Breaker Panel Specifications

PARAMETER	SPECIFICATION	REMARKS
Physical		
Weight	12 pounds (5.45 kilograms)	
Dimensions (HxWxD)	1.75 x 17.13 x 11.0 inches (44 x 435 x 280 mm)	See Figure 6 .
Color	Putty white	
Rack mounting	19- or 23-inch (EIA or WECO hole spacing)	Flush or with a recess of 1, 2, 3, or 4 inches (25.4, 50.8, 76.2, or 101.6 mm)
Electrical		
Operating voltages	-24 Vdc nominal	Input range: -21 to -30 Vdc
	-48 Vdc nominal	Input range: -42 to -56 Vdc
Input current	45 Amps max. per bus	90 Amps max. per panel
Circuit breaker rating	5 or 10 Amps	Positions are labeled
Circuit breaker positions	7 per bus	14 per panel
Max. circuit breaker size	10 Amps rating	45 Amps per bus
Input terminal type	2-hole compression lug	Stud type accepting up to #6 AWG wire
Output terminal type	7-position screw-down barrier terminal strip	Accepting a variety of wire up to 12 AWG wire
Alarm contact current	1 Amp max.	
Grounding connection	Two #10 studs and nuts on 0.625 centers	
Environmental		
Operating temperature	-5° C to +55° C	
Storage temperature	-45° C to +85° C	
Humidity range	0% to 95% humidity	No condensation
Altitude range	-197 feet (0.06 km) to 13,000 feet (3.96 km) above sea level	
Acoustic noise	0 dBA above ambient	
Heat dissipation (no load)	1 Watt per bus	
Heat dissipation (fully loaded)	30 Watts max. at 25° C ambient temperature, full load	

2 ACCESSORIES

The following accessories for the PowerWorx circuit breaker panel are available:

- Cable management bar with mounting screws. Provides cable tie points. Installed at rear of circuit breaker panel by fastening ends of bar to both sides of the panel;
- Various sizes of two-hole compression lugs for input power connection.
- Lug terminals to connect #10 AWG wire to earth ground.
- Circuit breaker designation card kit.

3 UNPACKING AND INSPECTION

Unpack and inspect the various components as follows:

1. Inspect the exterior of the shipping container for evidence of handling that may have damaged the components in the container.
2. Unpack each container while carefully checking the contents for damage and verify with the packing slip.
3. File a claim with the commercial carrier and notify ADC Customer Service if damage is detected or if parts are missing. Save damaged cartons for inspection by the carrier.
4. Refer to [Section 8, Customer Information and Assistance](#) at the back of this manual, for repair, replacement, and warranty information.

Save all shipping containers for use if the equipment requires return shipment at a future date.

4 INSTALLATION

The circuit breaker panel must be installed in a central office, equipment room, or restricted access location.

The following guidelines should be used when mounting the circuit breaker panel in a rack:

- Mount the circuit breaker panel in the uppermost area of the rack to reduce exposure of the power wiring.
- Provide a minimum of 1.75 inches (4.45 cm) of air space (one rack space) between the top of the circuit breaker panel and the next item in the rack for cooling.



Caution: *This equipment employs electrical voltage and amperage levels which may be considered an electrical hazard. Care should be exercised to assure that only qualified personnel are allowed to install, operate, maintain, or otherwise come in contact with this equipment when the circuit breaker panel is energized.*



Warning: *Never install power equipment in a wet location or during a lightning storm. When installing or modifying power lines, disconnect lines at the source before working with uninsulated lines or terminals to prevent electrical shock.*

4.1 Installation Tools Required

The following tools are required to install the circuit breaker panel:

- Screwdrivers (both Phillips and flatblade)
- Torque screwdriver calibrated in pound-force inches or Newton meters
- 3/8-inch and 7/16-inch bits (for torque screwdriver)
- Wire cutter
- Wire stripper
- Compression lug crimper
- Multimeter
- Heat gun

4.2 Materials Required

The following materials are required to install the circuit breaker panel:

- Insulated copper wire for input and output power wires (see [Appendix A](#))
- Heat-shrink tubing
- Multimeter

4.3 Pre-Installation Testing

Each circuit breaker panel is thoroughly tested at the ADC factory before being shipped. However, before the panel is installed, continuity tests should be performed to verify that no internal damage has occurred during shipping and handling.

Using a multimeter that is set to perform a continuity check, perform the following tests.

Test 1: Input Battery to Input Return—Use the following procedure:

1. Connect one test probe to the A bus BATT input power terminal and the other test probe to the A bus RTN input power terminal (Figure 7).

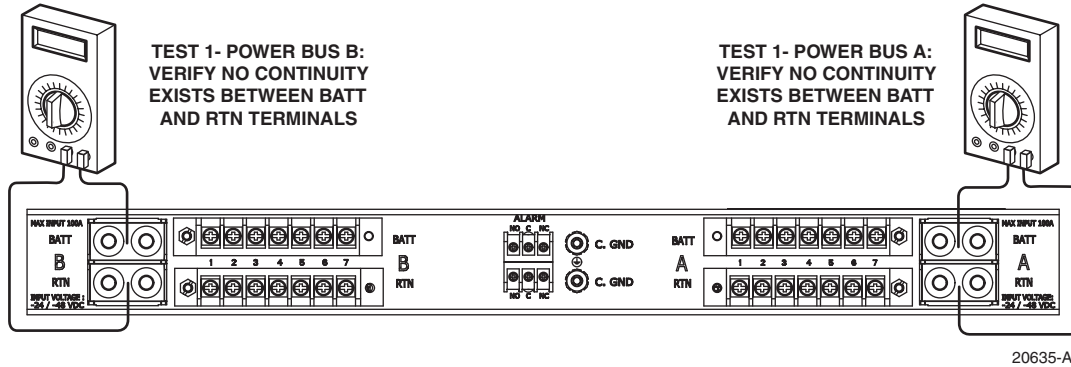

Figure 7. Test 1: Input Battery to Input Return

2. Verify that no continuity exists between the BATT input and RTN input terminals.
3. Repeat the test procedure for the B bus.

Test 2: Input Battery to Output Battery—Use the following procedure (Figure 8):

1. Starting on the A bus, at the output terminal for circuit 1, connect the negative test probe to the bus A input BATT power terminal and the positive test probe to bus A output BATT power terminal for the circuit being tested.

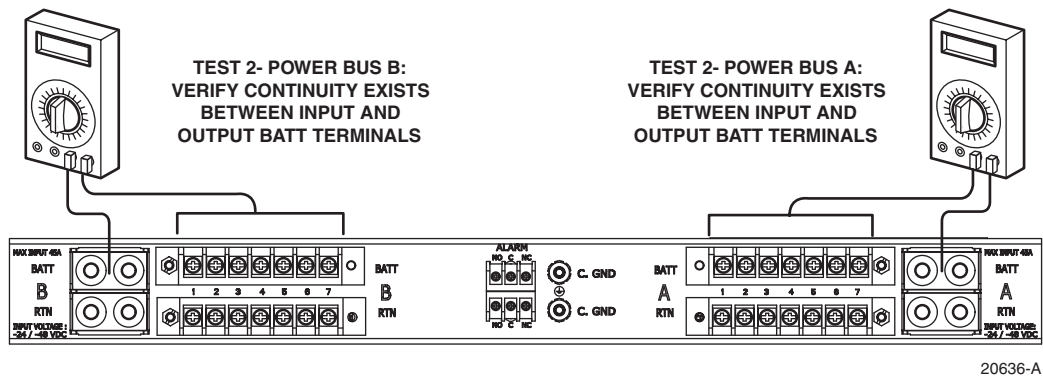

Figure 8. Test 2: Input Battery to Output Battery

2. Turn on circuit breaker A1.
3. Verify that continuity exists between the specified terminals.
4. Repeat the test procedure for each remaining circuit (A 2-7, B 1-7).

Test 3: Input Return to Output Return—Use the following procedure:

- Starting at bus A, connect the negative test probe to the RTN input power terminal and the positive test probe to the RTN output power terminal for circuit 1 (Figure 9).

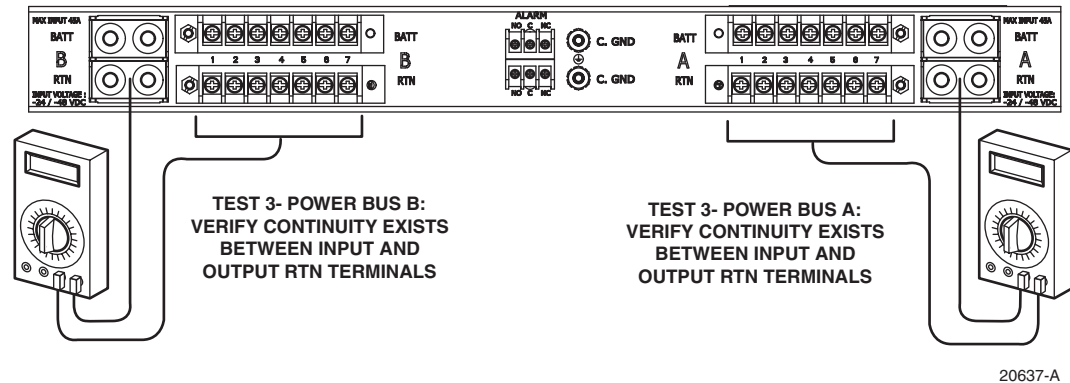

Figure 9. Test 3: Input Return to Output Return

- Verify that continuity exists between the specified terminals.
- Repeat the test procedure for each remaining circuit (A 2-7, B 1-7).

Test 4: Alarm Terminals—Use the following procedure:

- Note:** This procedure tests the alarm indicator contacts as they should be with no power being supplied to the panel. In this state, the normally open (NO) contacts should be closed and the Normally Closed (NC) contacts should be open.

- Starting at the top set of alarm terminals on the right rear side of the panel, verify that no continuity exists between the C and NC terminals (Figure 10).

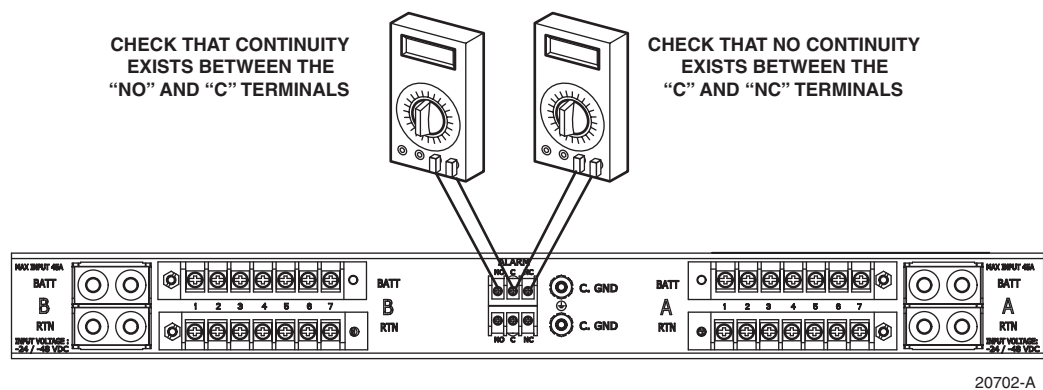

Figure 10. Test 4: Alarm Contacts

- Connect the test probes between the C and NO terminals on the first set of alarm terminals. Verify that continuity exists between the C and NO terminals.
- Repeat the test procedure for the other set of alarm terminals.

4.4 Cable Management Bar (Optional Accessory)

Before installing the circuit breaker panel in the rack, determine if the optional cable management bar was ordered for this panel. If so, install the bar before mounting the panel on the rack.

Use the following procedure:

1. Position the cable management bar at the rear of the panel as shown in [Figure 11](#).
2. Secure the bar to the panel using the 0.25-inch (6.35 mm) long 4-40 screws supplied with the cable management bar.

► **Note:** The cable management bar can be recess-mounted by using the mounting holes closest to the front of the panel.



Caution: When attaching the cable management bar to the circuit breaker panel, use only the hardware supplied with the cable management bar. Use of any other hardware could cause contact with internal parts of the circuit breaker panel. If parts are missing, please contact ADC.

► **Note:** A circuit breaker panel with the cable management bar attached may exceed the 12-inch (305 mm) overall depth objective described in GR-63 CORE, 02-14.

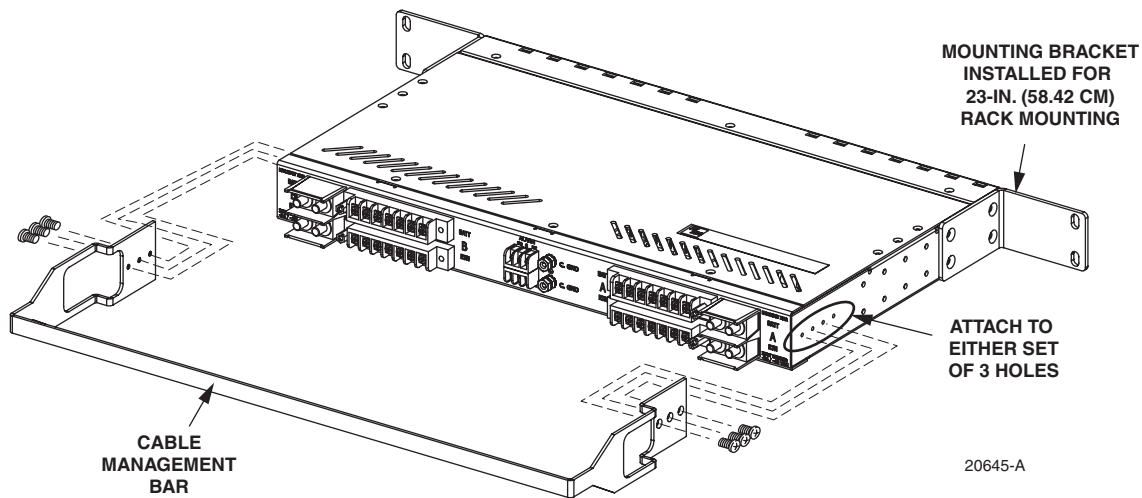

Figure 11. Cable Management Bar Installation

4.5 Mounting Panel on Rack

The circuit breaker panel can be mounted in either a 19- or 23-inch (48.26 or 58.42 cm) wide rack using the 1.75-inch high (4.45 cm), 19- or 23-inch rack mounting brackets. The brackets, mounting screws, and washers are provided with the panel.



Caution: When attaching the mounting brackets to the circuit breaker panel, use only the 5/16-inch (7.935 mm) long, chromate finish, flathead, thread forming screws supplied with the panel. Use of any other hardware could cause contact with internal parts of the circuit breaker panel. If parts are missing, please contact ADC.

Use the following procedure to install the circuit breaker panel in the rack:

1. Select either the 19-inch or 23-inch brackets.
2. Attach the mounting brackets to the sides of the chassis using the eight 5/16-inch (7.94 mm) 8-32 flathead thread-forming screws provided. Tighten the screws to 15 pound-force inches (1.7 Newton meters) of torque to insure grounding. Refer to [Figure 12](#).

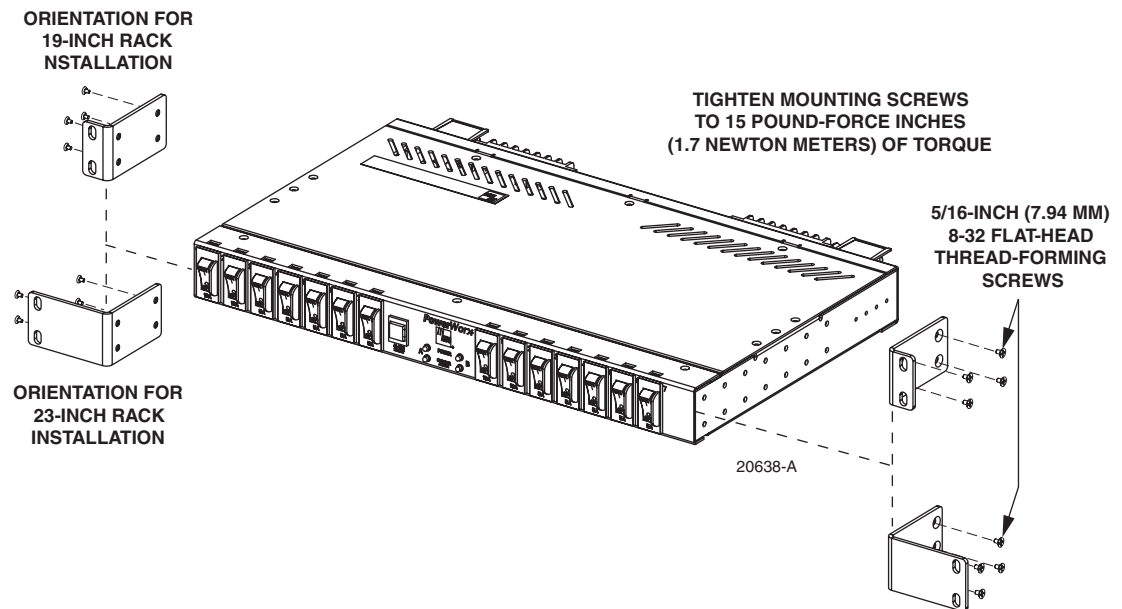

Figure 12. Repositioning the Mounting Brackets (Optional)

3. Place the circuit breaker panel in the specified mounting space within the rack as shown in [Figure 13](#).
- **Note:** Provide one rack unit of space above and below the circuit breaker panel for air circulation.
4. Secure the panel to the rack using the four 3/8-inch (9.525 mm) long, 12-24 pan-head screws and #12 flat washers provided (use star washers when required by local practice). Tighten the screws to 27 pound-force inches (3.1 Newton meters) of torque.

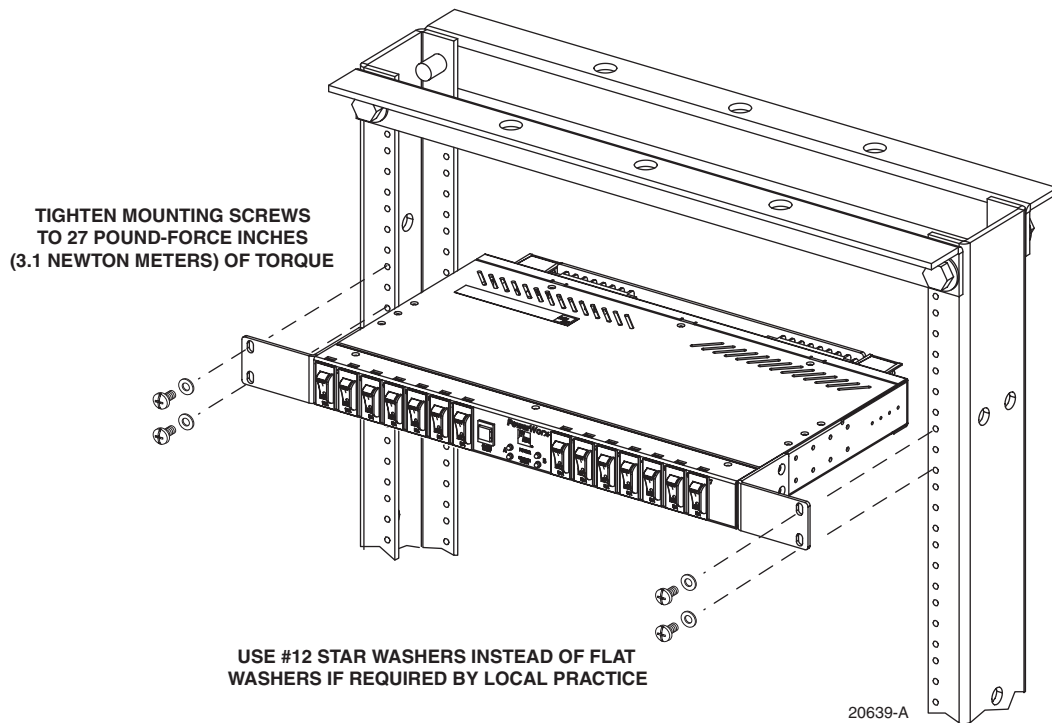

Figure 13. Mounting Panel on Rack

4.6 Installing Designation Cards

Attach the designation card holder either to the underside of the circuit breaker panel, to one of the panel mounting brackets, to part of the rack, or at a location close to the panel. Remove the backing from the back of the card holder and press the card holder against the mounting surface. Fill out one of the cards (see [Figure 4 on page 8](#)) with circuit information as desired and insert it in the card holder.

4.7 Installing Voltage Designation Label

Write the voltage used in the circuit breaker panel on the voltage designation label (see [Figure 5 on page 8](#)) and attach the label to the panel.

4.8 Installing Ground Wires

Connect chassis ground (labeled “C. GND”) to the equipment rack ground ([Figure 14](#)) using the following chassis grounding recommendations:

- Chassis grounding conductor connection point: #10 screws and nuts on 0.625 inch (15.875 mm) centers. Two #10 crimp ring terminals, for use with #10 AWG wires, are provided.

- Chassis ground conductor: Use two #10 AWG wires if using both chassis ground connectors or one #6 AWG wire if using one chassis ground connector from connector(s) to equipment rack.

Torque the nuts to 20 pound-force inches (2.2 Newton meters) maximum. Route the free end of the chassis grounding wire to an approved office ground source. Terminate the wire at the ground source.

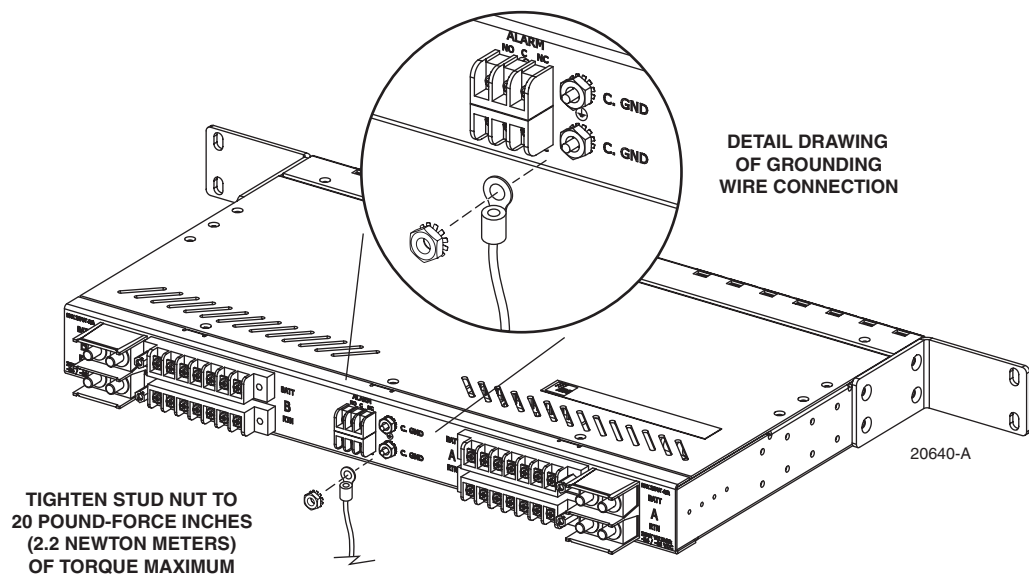

Figure 14. Installing Ground Wires

4.9 Connecting Alarms

Normally open (NO) and normally closed (NC) alarm contacts are provided for connecting the circuit breaker panel to an external alarm system. Alarm connections are provided through two single row terminal strips, each with three screws, located on the rear side of the panel. The terminal strips can accept #16 to #30 AWG solid copper, either with crimp-on spade lugs or ring connectors, or without lugs with insulation stripped back. Use the following procedure to connect an external alarm system to the alarm terminals on the circuit breaker panel chassis.



Caution: All Vdc input wiring shall be routed away from any sharp edges and properly secured in place to prevent chaffing and to provide strain relief. This may be achieved by tie-wrapping the wires to the rack frame, or by equivalent means.

1. Obtain #16 to #30 AWG wire.
2. Run four lengths of wire from the circuit breaker panel to the external alarm system.
3. Strip back the insulation approximately 0.38 inches (9.5 mm) on the ends of the wires by the circuit breaker.
4. If using spade lug or ring connectors, crimp the connectors onto the wires and then install the connectors on the alarm contacts (Figure 15).

5. If connecting bare wire, wrap the bare wire around the contact in a clockwise direction.
6. Tighten the screws to approximately 9 pound-force inches (1 Newton meter) of torque.
7. Terminate the other ends of the wires at the appropriate terminals in the external alarm system.

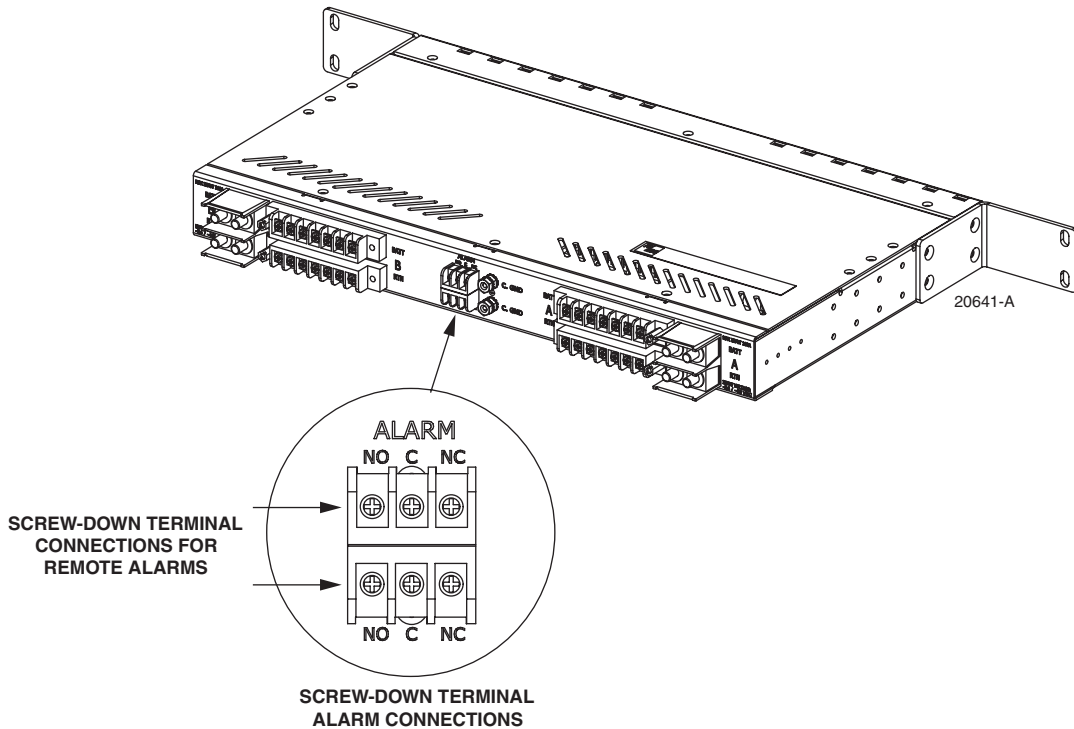

Figure 15. Alarm Terminals

4.10 Connecting Output

Output power is supplied to the protected equipment through the output power screw-down terminal strips located on the rear of the panel. Wire leads should be equipped with crimp-on spade lugs or ring connectors that have a minimum width of 0.32 inches (81.3 mm). The terminals also accommodate copper wire without lugs (insulation stripped back). The terminals can accept a variety of wire sizes up to #12 AWG with crimp-on spade lug or ring connectors or wires in sizes from #12 AWG to #22 AWG with insulation stripped back. Follow local code. In selecting wire size, refer to [Appendix A](#).



Caution: Connecting the equipment to the wrong circuit may cause damage to the equipment or the circuit breaker panel.

1. Obtain the required lengths of wire for use as the output power cables.
2. Equip wire leads with spade or ring-type compression lugs (maximum width 0.32 inches) or prepare a bare wire contact.

3. Terminate the wires at the screw-down barrier strip as follows (Figure 16):
 - **Negative wires (Battery -):** Connect to the BATT output power terminals.
 - **Positive wires (Return +):** Connect to RTN output power terminals.

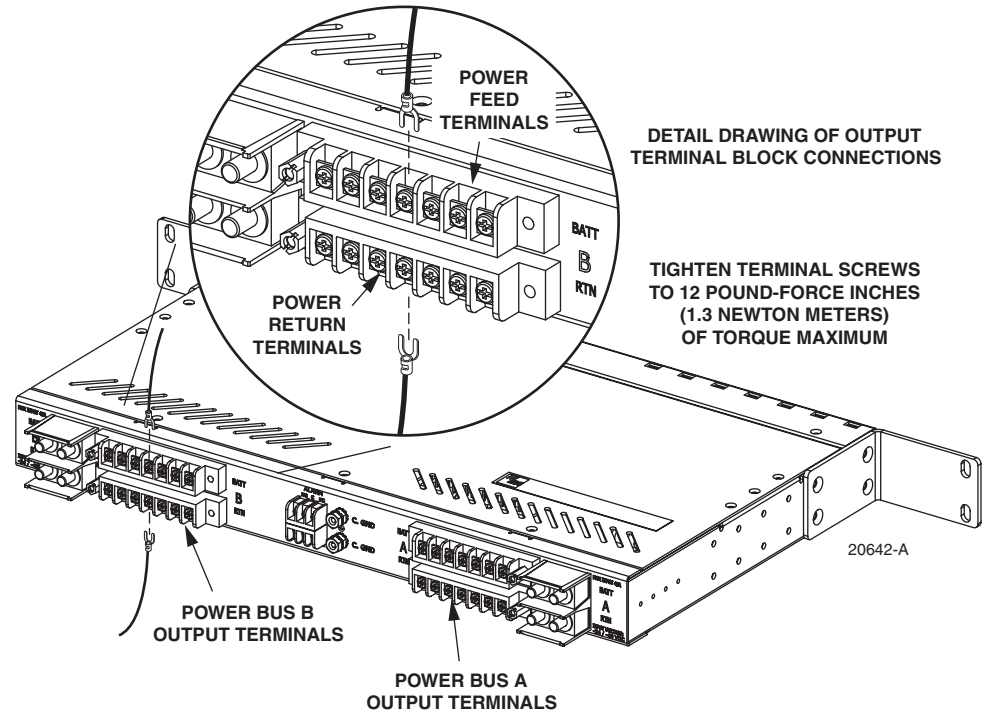

Figure 16. Connecting Power Output

4. Tighten the output power terminal block nuts to 12 pound-force inches (1.3 Newton-meters) maximum of torque.
5. Route the free end of each output power cable to the equipment for connection.

4.11 Connecting Input

Input power is supplied to the circuit breaker panel through the A and B input power terminal blocks located on the rear side of the panel. Each block consists of two pairs of 0.25-inch studs that are used for connecting the negative (BATT) and positive (RTN) input power cables. The stud pairs are mounted on 0.625 inch centers and accept 2-hole compression lugs. The maximum lug width is 0.62 inches. Nuts with captive washers are provided to secure the compression lugs to the terminal block. In selecting wire size, follow local code. Refer to [Appendix A](#) for ampacity guideline.



Warning: Use of one bus only on a dual bus panel will result in false alarms for the unused bus. Power is required on both buses on a dual bus panel for normal operation.



Caution: Connect only the input voltage wire (labeled BATTERY, BATT, NEGATIVE, NEG, or – and/or the voltage value) to the connector on the circuit breaker panel labeled BATT (battery). Connect only the input return wire (labeled RTN, RETURN, POSITIVE, POS, +, or BATTERY GROUND) to the connector on the circuit breaker panel labeled RTN (return).



Caution: Caution should be taken to not reverse input wires to the circuit breaker panel. In the circuit breaker panel, the internal battery (negative voltage) wiring is protected and the internal return wiring is not protected by circuit breakers.

Use the following procedure to connect input power wires (Figure 17):

1. Obtain four lengths of copper wire for use as the input power cables.
2. Strip back 7/8 inches of insulation from one end of each wire.
3. Slide a 2-inch length of heat shrink insulation over the end of each wire.
4. Terminate one end of each wire with 2-hole lug terminals (provided; requires crimper).
5. Slide the heat shrink insulation down to the lug terminal so the barrel end of the terminal is covered.

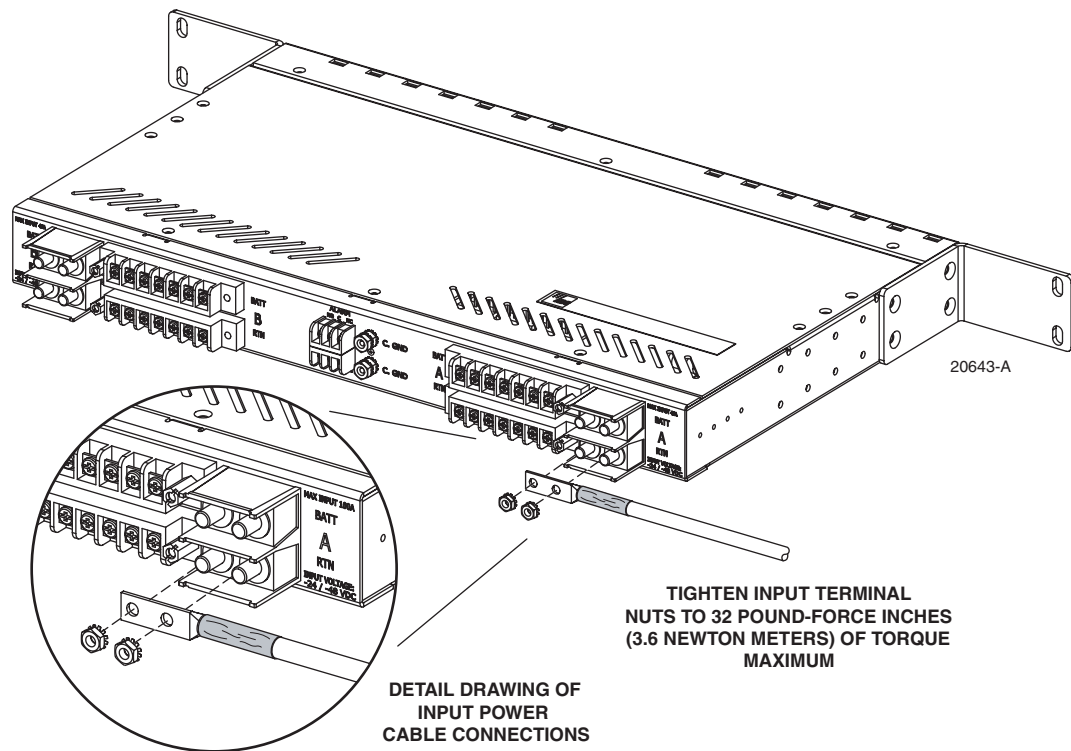

Figure 17. Installing Input Power

- ▶ **Note:** Replace the protective cover on the circuit breaker panel after all the wiring connections are made and before power is applied to the panel (refer to [Section 4.12, Installing Protective Covers](#), on page 23)

6. Use a heat gun to apply heat to the heat shrink insulation until it tightens around the wire and barrel end of the terminal.
7. Use the nuts (with captive washers) provided to secure the input power wires to the specified terminals.
8. Connect the negative inputs to the negative (BATT) terminals on the A and B input power terminal blocks.
9. Connect the positive inputs to the positive (RTN) terminals on the A and B input power terminal blocks.
10. Use a torque wrench (with a 7/16-inch socket) to tighten the input power terminal block nuts to 32 pound-force inches (3.6 Newton meters) maximum of torque.
11. Route the free ends of the input power cables to the office battery source.
12. Connect the input power cables to the office battery power source in accordance with applicable local electrical codes and/or National Electrical Codes. Refer to [Appendix A](#). Do not apply power to the circuit breaker panel until instructed to do so for testing (see [Section 5](#)).

4.12 Installing Protective Covers

1. Snap the two small protective covers on the input and output terminals ([Figure 18](#)).
2. Fasten the large cover to the four corners of the output power terminal blocks using the four #6-32 screws provided.

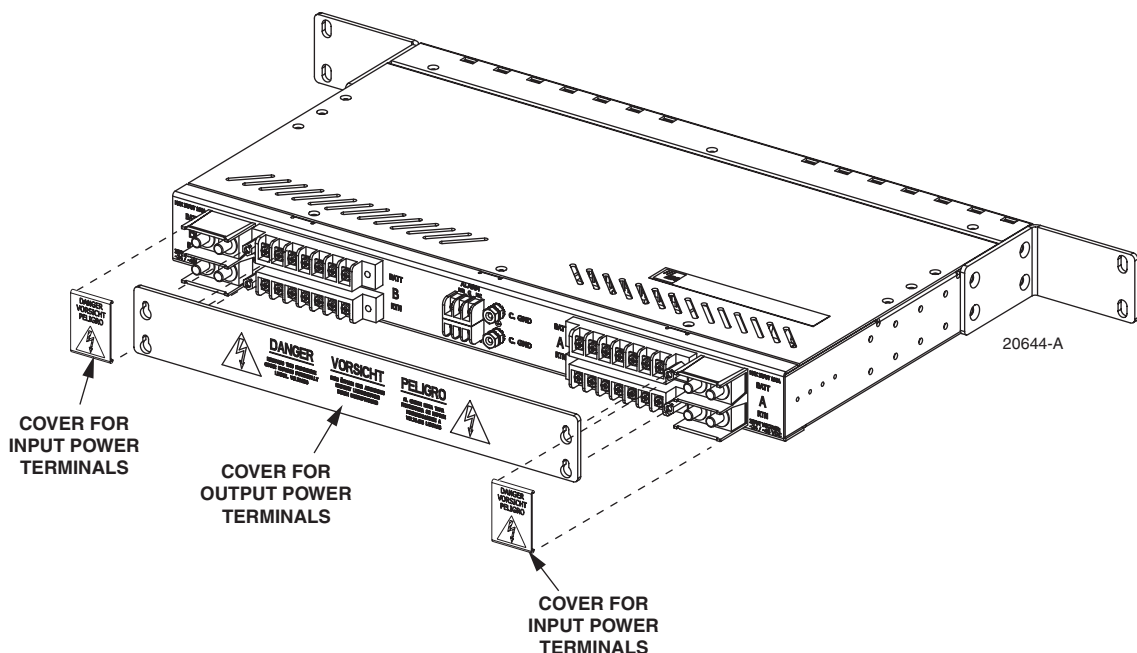

Figure 18. Installing Protective Covers

5 TESTING

This section describes how to test the circuit breaker panel after installation.

5.1 Testing Power Indicators and Connection Polarity

Use the following procedure to check that the power input wires are connected for correct polarity,

1. Verify that the input power cables are connected to the correct terminals.
2. Verify that the circuit breakers for all circuits are on.
3. Using a multimeter set to measure DC voltage, measure the voltage between each input power (RTN) terminal and chassis ground. The voltage level should be less than 2.0 Vdc.
4. If the voltage is much higher, and reads out in the -30 to -60 Vdc range, the input leads are probably reversed. If this appears to be true, power down the panel. Disconnect the negative (BATT) and positive (RTN) input lugs and switch them around. Power up the panel and check again to verify that the higher voltage is on the negative (BATT) lug.
5. If the problem is such that you can't figure it out with these instructions, consult with ADC Technical Assistance Center (TAC).

5.2 Testing Alarm Contacts Normal State

Use the following procedure to test the alarm connections for correct functioning of NO and NC terminals.

1. Verify that the alarm contacts remain in the normal state when power is applied and all circuit breakers in the "on" position.
2. Using a multimeter that is set to test for continuity, connect the probes alternately between the C and NC terminals and the C and NO terminals for all sets of alarm terminals.
3. Verify that continuity exists between the C and NC terminals and that no continuity exists between the C and NO terminals.

6 OPERATION

This section describes how to operate the circuit breaker panel. Operation includes connecting new equipment and using the Reset Switch.

6.1 Connecting New Equipment

New equipment may be connected to unused output power circuits following installation and testing of the circuit breaker panel. Use the following procedure for connecting the output power wires for new equipment to a previously installed panel:



Warning: *The circuit breaker panel uses electrical voltage and current levels that may be considered an energy hazard. Only qualified personnel should be allowed to install, operate, maintain, or otherwise come into contact with this equipment when energized. Only insulated tools should be used on energized elements of the panel.*

1. Remove the large protective cover from the rear side of the panel.
2. Turn off the circuit breaker for the circuit to which equipment will be added.
3. Connect the output power wiring to the power output terminals. Wire leads should be equipped with crimp-on spade lugs or ring connectors that have a minimum width of 0.32 inches (81.3 mm). The terminals also accommodate copper wire without lugs (insulation stripped back). The terminals can accept a variety of wire sizes up to #12 AWG with crimp-on spade lug or ring connectors or wires in sizes from #12 AWG to #22 AWG with insulation stripped back. In selecting wire size, follow local code referring to the ampacity guidelines provided in [Appendix A](#).



Caution: *Use care to avoid shorting out adjacent terminals when connecting new output power wiring to a powered circuit breaker panel. Shorting can cause injury and damage the panel or the connected equipment.*

4. Re-install the protective cover over the output power terminal blocks.
5. Switch the circuit breaker to the on position and verify that the breaker alarm indicator turns off.

6.2 Using the Reset Switch

The purpose of the Reset switch is to allow you to clear an alarm when you turn off a circuit breaker. When you press the Reset switch, any alarms currently existing are cleared but any new alarm will be reported.

Use the following procedure:

1. If for some reason you need to turn off power to a particular circuit, switch the circuit breaker to an off position and then immediately press the Reset Switch.
2. When ready, turn the circuit back on.

► **Note:** Switching the circuit breaker back on returns the circuit to the normal alarm reporting mode. If any other circuit has an active alarm that was cleared by the Reset switch, that alarm will continue to be cleared until the circuit breaker for that circuit is turned back on.

7 MAINTENANCE

Maintenance includes performing a routine inspection and replacing a circuit breaker.

7.1 Performing a Routine Inspection



Caution: Take care to avoid damaging the circuit breakers or wiring.

1. Inspect the panel for damage to the circuit breakers and for damaged or broken wires at the power and external alarm connections.
2. If excessive dirt is found during the inspection, brush or wipe dust and dirt from the panel with a soft bristle brush or soft cloth.
3. If any circuit breaker is broken or damaged, replace the circuit breaker.

7.2 Replacing a Circuit Breaker

Any existing circuit breaker may be field-replaced with an identical circuit breaker or with a breaker that has the same rating. Use the following procedure to replace an existing circuit breaker with a new breaker:

1. Turn-off or disconnect the power from the power bus (either A or B) that supplies current to the circuit breaker to be replaced.
2. Press the Reset switch to suppress alarms for the “off” circuits.



Danger: During normal operation, the terminal connections on the circuit breakers are electrically energized. Failure to disconnect the power from the power bus that supplies current to the circuit breaker being replaced may cause severe personal injury to the installer and/or equipment damage.

3. Insert a flat-bladed screwdriver into the slot above the circuit breaker as shown in [Figure 19](#).
4. Push down and forward on the upper circuit breaker lock tab until the top of the circuit breaker is released from the panel.
5. Hold the top edge of the circuit breaker to keep the circuit breaker from snapping back into the panel when the screwdriver is withdrawn from the slot.
6. Insert a flat-bladed screwdriver into the slot below the circuit breaker.
7. Push down and forward on the lower circuit breaker lock tab until the bottom of the circuit breaker is released from the panel.
8. Pull the circuit breaker forward and out of the panel to expose the wiring connections on the rear side of the circuit breaker.

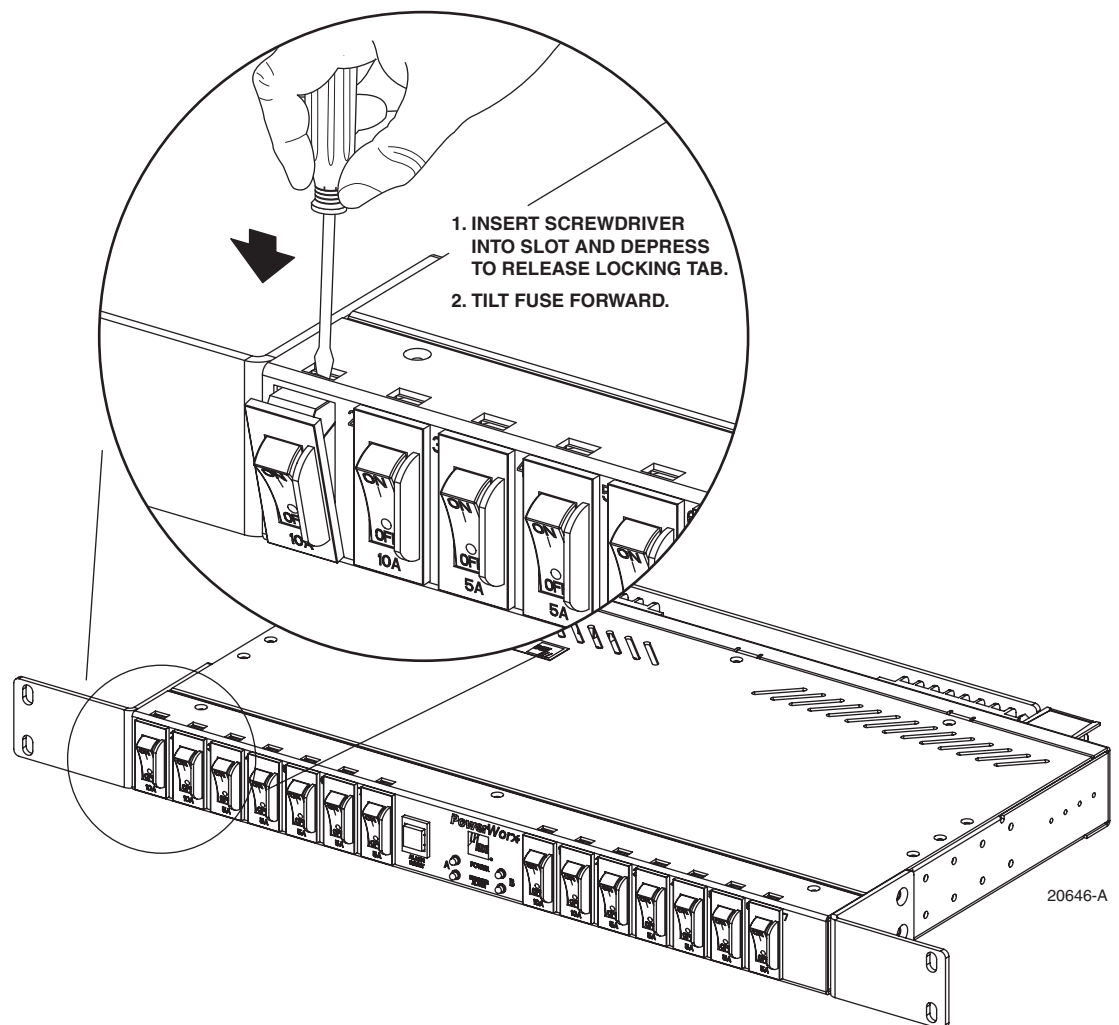

Figure 19. Releasing the Circuit Breaker Lock Tab

9. Disconnect the power and load wires (#14 AWG white and black wires) and the alarm wires (#24 AWG black wires) from the terminals on the rear side of the circuit breaker as shown in.
 10. Connect the power and load wires to the specified terminals on the rear side of the replacement circuit breaker (see Figure 20). Note that with the circuit breaker oriented as shown, the black load wire connects to the top terminal and the white power wire connects to the bottom (LINE) terminal.
 11. Connect the two alarm wires to the specified terminals on the rear side of the replacement circuit breaker (see Figure 20).
- ▶ **Note:** Do not connect any wires to the center terminal on the circuit breaker.
12. Insert the replacement circuit breaker into the opening in the panel and push inward until it locks into place.
 13. Reconnect the power to the power bus.

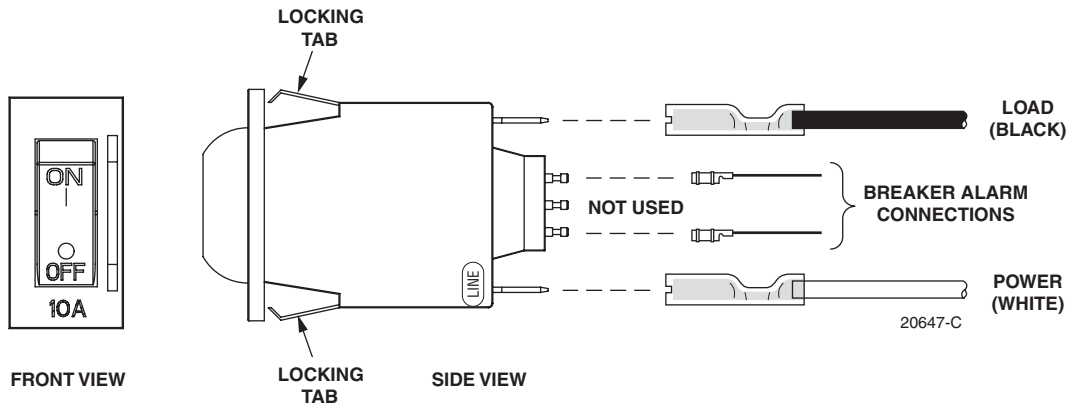

Figure 20. Circuit Breaker

8 CUSTOMER INFORMATION AND ASSISTANCE

PHONE:

U.S.A. OR CANADA

Sales: 1-800-366-3891 Extension 73000

Technical Assistance: 1-800-366-3891

Connectivity Extension 73475

Wireless Extension 73476

EUROPE

Sales Administration: +32-2-712-65 00

Technical Assistance: +32-2-712-65 42

EUROPEAN TOLL FREE NUMBERS

Germany: 0180 2232923

UK: 0800 960236

Spain: 900 983291

France: 0800 914032

Italy: 0800 782374

ASIA/PACIFIC

Sales Administration: +65-6294-9948

Technical Assistance: +65-6393-0739

ELSEWHERE

Sales Administration: +1-952-938-8080

Technical Assistance: +1-952-917-3475

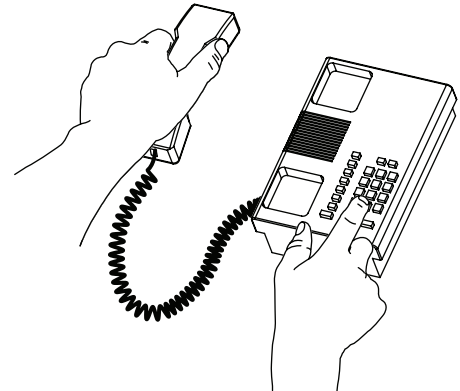

WRITE:

ADC TELECOMMUNICATIONS, INC
PO BOX 1101,
MINNEAPOLIS, MN 55440-1101, USA

ADC TELECOMMUNICATIONS (S'PORE) PTE. LTD.
100 BEACH ROAD, #18-01, SHAW TOWERS.
SINGAPORE 189702.

ADC EUROPEAN CUSTOMER SERVICE, INC
BELGICASTRAAT 2,
1930 ZAVENTEM, BELGIUM

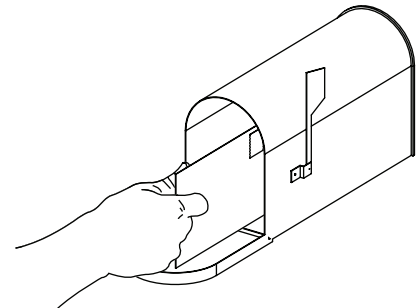

PRODUCT INFORMATION AND TECHNICAL ASSISTANCE:

connectivity.tac@adc.com

wireless.tac@adc.com

euro.tac@adc.com

asiapacific.tac@adc.com

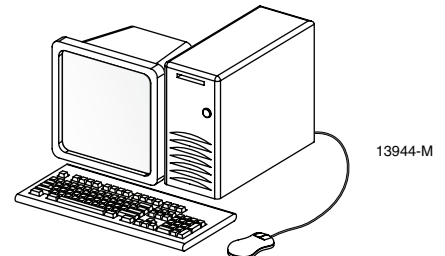

13944-M

Contents herein are current as of the date of publication. ADC reserves the right to change the contents without prior notice. In no event shall ADC be liable for any damages resulting from loss of data, loss of use, or loss of profits and ADC further disclaims any and all liability for indirect, incidental, special, consequential or other similar damages. This disclaimer of liability applies to all products, publications and services during and after the warranty period. This publication may be verified at any time by contacting ADC's Technical Assistance Center.



© 2006, ADC Telecommunications, Inc.
All Rights Reserved
Printed in U.S.A.

APPENDIX A: ALLOWABLE AMPACITIES OF INSULATED CONDUCTORS

This appendix provides guidelines for selecting AWG wire size based on the temperature rating of the conductor and the anticipated load. The information contained is from Table 310-16 of the National Electrical Code document, ANSI/NPFA 70 (1978).

- **Note:** Information for aluminum conductors has been omitted from the table here because copper conductors only are recommended for use with the ADC panel.

Table 310-16 (NEC): Allowable Ampacities of Insulated Conductors, Rated 0 Through 2000 Volts, 60° to 90°C (140° to 194°F), Not More Than Three Current-Carrying Conductors in Raceway or Cable or Earth (Directly Buried), Based on Ambient Temperature of 30°C (86°F)

SIZE AWG KCMIL	TEMPERATURE RATING OF CONDUCTOR		
	60°C (114°F)	60°C (114°F)	60°C (114°F)
	TYPES TW*, UF*	TYPES FEPW*, RH*, RHW*, THHW*, THW*, THWN*, XHHW*, USE*, ZW*	TYPES TBS, SA, SIS, FEP*, FEPB*, MI, RHH*, RHW-2, THHN*, THHW*, THW-2*, THWN-2*, USE-2, XHH, XHHW*, XHHW-2 ZW-2
18	14
16	18
14	20*	20*	25*
12	25*	25*	30*
10	30	35*	40*
8	40	50	55
6	55	65	75
4	70	85	95
3	85	100	110
2	95	115	130
1	110	130	150
1/0	125	150	170
2/0	145	175	195
3/0	165	200	225
4/0	195	230	260
250	215	255	290
300	240	285	320
350	260	310	350
400	280	335	380

Table 310-16 (NEC): Allowable Ampacities of Insulated Conductors, Rated 0 Through 2000 Volts, 60° to 90°C (140° to 194°F), Not More Than Three Current-Carrying Conductors in Raceway or Cable or Earth (Directly Buried), Based on Ambient Temperature of 30°C (86°F)

SIZE	TEMPERATURE RATING OF CONDUCTOR		
	60°C (114°F)	60°C (114°F)	60°C (114°F)
			TYPES TBS, SA, SIS, FEP*, FEPB*, MI, RHH*, RHW-2, THHN*, THHW*, THW-2*, THWN-2*, USE-2, XHH, XHHW* XHHW-2 ZW-2
	TYPES TW*, UF*	TYPES FEPW*, RH*, RHW*, THHW*, THW*, THWN*, XHHW*, USE*, ZW*	
500	320	380	430
600	355	420	475
700	385	460	520
750	400	335	380
800	410	490	555
900	435	520	585
1000	455	545	615
1250	495	590	665
1500	520	625	705
1750	545	650	735
2000	560	665	750
CORRECTION FACTORS			
For ambient temperatures other than 30C (86F), multiply the allowable ampacities shown by the appropriate factor shown below.			
21-25	1.08	1.05	1.04
26-30	1.00	1.00	1.00
31-35	.91	.94	.96
36-40	.82	.88	.91
41-45	.71	.82	.87
46-50	.58	.75	.82
51-55	.41	.67	.76
56-6058	.71
61-7033	.58
71-8041

* Unless otherwise specifically permitted in the code, as defined in the NEC document cited (ANSI/NEC 70), the overcurrent protection for conductor types marked with an asterisk (*) shall not exceed 15 amperes for No. 14, 20 amperes for No. 12, and 30 amperes for No. 10 copper, after any correction factors for ambient temperature and number of conductors have been applied.



www.adc.com

Free Manuals Download Website

<http://myh66.com>

<http://usermanuals.us>

<http://www.somanuals.com>

<http://www.4manuals.cc>

<http://www.manual-lib.com>

<http://www.404manual.com>

<http://www.luxmanual.com>

<http://aubethermostatmanual.com>

Golf course search by state

<http://golfingnear.com>

Email search by domain

<http://emailbydomain.com>

Auto manuals search

<http://auto.somanuals.com>

TV manuals search

<http://tv.somanuals.com>