



**ML-130**  
**Service Manual**  
**Phase 6 Microprocessor**  
**Timer Controls**

---

---

**American Dryer Corporation**  
88 Currant Road  
Fall River, MA 02720-4781  
Telephone: (508) 678-9000 / Fax: (508) 678-9447  
e-mail: techsupport@amdry.com

# Retain This Manual In A Safe Place For Future Reference

American Dryer Corporation products embody advanced concepts in engineering, design, and safety. If this product is properly maintained, it will provide many years of safe, efficient, and trouble-free operation.

*ONLY qualified technicians should service this equipment.*

**OBSERVE ALL SAFETY PRECAUTIONS** displayed on the equipment or specified in the installation/operator's manual included with the dryer.

The following "FOR YOUR SAFETY" caution **must be** posted near the dryer in a prominent location.

**FOR YOUR SAFETY**

Do not store or use gasoline or other flammable vapors or liquids in the vicinity of this or any other appliance.

**POUR VOTRE SÉCURITÉ**

Ne pas entreposer ni utiliser d'essence ni d'autres vapeurs ou liquides inflammables dans le voisinage de cet appareil ou de tout autre appareil.

We have tried to make this manual as complete as possible and hope you will find it useful. **ADC** reserves the right to make changes from time to time, without notice or obligation, in prices, specifications, colors, and material, and to change or discontinue models.

## Important

For your convenience, log the following information:

**DATE OF PURCHASE** \_\_\_\_\_ **MODEL NO.** ML-130

**DISTRIBUTORS NAME** \_\_\_\_\_

**Serial Number(s)** \_\_\_\_\_

\_\_\_\_\_

\_\_\_\_\_

Replacement parts can be obtained from your distributor or the **ADC** factory. When ordering replacement parts from the factory, you can FAX your order to **ADC** at (508) 678-9447 or telephone your orders directly to the **ADC** Parts Department at (508) 678-9000. Please specify the dryer **model number** and **serial number** in addition to the **description** and **part number**, so that your order is processed accurately and promptly.

The illustrations on the following pages may not depict your particular dryer exactly. The illustrations are a composite from the various dryer models. Be sure to check descriptions of the parts thoroughly before ordering.

**“IMPORTANT NOTE TO PURCHASER”**

Information must be obtained from your local gas supplier on the instructions to be followed if the user smells gas. These instructions must be posted in a prominent location near the dryer.

## **IMPORTANT**

**YOU MUST DISCONNECT and LOCKOUT THE ELECTRIC SUPPLY and THE GAS SUPPLY or THE STEAM SUPPLY BEFORE ANY COVERS or GUARDS ARE REMOVED FROM THE MACHINE TO ALLOW ACCESS FOR CLEANING, ADJUSTING, INSTALLATION, or TESTING OF ANY EQUIPMENT per OSHA (Occupational Safety and Health Administration) STANDARDS.**

“Caution: Label all wires prior to disconnection when servicing controls. Wiring errors can cause improper operation.”

«Attention: Lors des opérations d'entretien des commandes étiqueter tous fils avant de les déconnecter. Toute erreur de câblage peut être une source de danger et de panne.»

## **CAUTION**

**DRYERS SHOULD NEVER BE LEFT UNATTENDED WHILE IN OPERATION.**

## **WARNING**

**CHILDREN SHOULD NOT BE ALLOWED TO PLAY ON OR NEAR THE DRYER(S).  
CHILDREN SHOULD BE SUPERVISED IF NEAR DRYERS IN OPERATION.**

## **FOR YOUR SAFETY**

**DO NOT DRY MOP HEADS IN THE DRYER.  
DO NOT USE DRYER IN THE PRESENCE OF DRY CLEANING FUMES.**

## **WARNING**

**UNDER NO CIRCUMSTANCES should the door switch or the heat circuit devices ever be disabled.**

### **WARNING**

The dryer must never be operated with any of the back guards, outer tops, or service panels removed. **PERSONAL INJURY or FIRE COULD RESULT.**

### **WARNING**

**DRYER MUST NEVER BE OPERATED WITHOUT THE LINT FILTER/SCREEN IN PLACE, EVEN IF AN EXTERNAL LINT COLLECTION SYSTEM IS USED.**

### **IMPORTANT**

**PLEASE OBSERVE ALL SAFETY PRECAUTIONS displayed on the equipment and/or specified in the installation and operator's manual included with the dryer.**

Dryers **must not** be installed or stored in an area where it will be exposed to water or weather.

The wiring diagram for the dryer is located in the front electrical control box area.

# *Table of Content*

## **SECTION I**

<b>IMPORTANT INFORMATION .....</b>	<b>3</b>
A. Safety Precautions .....	3

## **SECTION II**

<b>ROUTINE MAINTENANCE .....</b>	<b>5</b>
A. Cleaning .....	5
B. Adjustments .....	6
C. Lubrication .....	6

## **SECTION III**

<b>INSTALLATION REQUIREMENTS .....</b>	<b>7</b>
A. Enclosure, Air Supply, and Exhaust Requirements .....	7
B. Electrical and Gas Requirements .....	7
C. Operational Service Check Procedure .....	8

## **SECTION IV**

<b>DESCRIPTION OF PARTS .....</b>	<b>10</b>
A. Control Box .....	10
B. Drive Motor .....	10
C. HSI (Hot Surface Ignition) Module (Gas Models Only) .....	10
D. Gas Burner Assembly .....	11
E. Blower Motor and Impellor .....	11
F. Idler Assembly .....	11
G. Tumbler (Basket) Bearing and Pulley Arrangement .....	12
H. Tumbler (Basket) .....	12
I. Main Door Switch .....	12
J. Sail Switch (Gas and Electric Models Only) .....	13
K. Hi-Limit (Gas and Electric Models Only) .....	13
L. Manual Reset Thermostat .....	13
M. Lint Drawer .....	14
N. Lint Drawer Switch .....	14
O. Steam Damper System .....	14

## **SECTION V**

<b>SERVICING .....</b>	<b>15</b>
A. Computer Controls .....	15
B. Ignition Controls .....	17
C. Thermostats .....	21
D. Sail Switch Assembly (Gas and Electric Models Only) .....	23
E. Front Panel and Main Door Assemblies .....	23
F. Pulleys .....	26
G. Tumbler (Basket) Assembly .....	28
H. Bearings .....	30
I. V-Belts .....	32
J. Motors .....	33
K. Impellor .....	34
L. Lint Drawer Assembly .....	34

## **SECTION VI**

<b>TROUBLESHOOTING .....</b>	<b>35</b>
------------------------------	-----------

## **SECTION VII**

<b>PHASE 6 OPL SYSTEM DIAGNOSTICS .....</b>	<b>39</b>
A. Diagnostic (L.E.D. [light emitting diode] Display) Failure Codes .....	39
B. L.E.D. (light emitting diode) Display Indicators .....	41
C. Phase 6 OPL Microprocessor Controller (Computer) Relay Output L.E.D. (light emitting diode) Indicators .....	42
D. L.E.D. Codes .....	46
E. Computer Logic and Wiring Diagram .....	48

## **SECTION VIII**

<b>TECHNICAL INFORMATION .....</b>	<b>54</b>
A. Motor Plate (High and Low Voltage) .....	54
B. Data Label .....	55
C. How to Use a Manometer .....	56
D. Tool List .....	57

# SECTION I

## IMPORTANT INFORMATION

### A. SAFETY PRECAUTIONS

**WARNING:** For your safety, the information in this manual *must be* followed to minimize the risk of fire or explosion or to prevent property damage, personal injury, or loss of life.

**WARNING:** The dryer *must never be* operated with any of the back guards, outer tops, or service panels removed. **PERSONAL INJURY or FIRE COULD RESULT.**

1. **DO NOT** store or use gasoline or other flammable vapors and liquids in the vicinity of this or any other appliance.
2. Purchaser/user should consult the local gas supplier for proper instructions to be followed in the event the user smells gas. The instructions **should be** posted in a prominent location.
3. WHAT TO DO IF YOU SMELL GAS...
  - a. **DO NOT** try to light any appliance.
  - b. **DO NOT** touch any electrical switch.
  - c. **DO NOT** use any phone in your building.
  - d. Clear the room, building, or area of **ALL** occupants.
  - e. Immediately call your gas supplier from a neighbor's phone. Follow the gas supplier's instructions.
  - f. If you **cannot** reach your gas supplier, call the fire department.
4. Installation and service **must be** performed by a qualified installer, service agency, or gas supplier.
5. Dryer(s) **must be** exhausted to the outdoors.
6. Although **ADC** produces a very versatile machine, there are some articles that, due to fabric composition or cleaning method, **should not be** dried in it.

**WARNING:** Dry only water-washed fabrics. **DO NOT** dry articles spotted or washed in dry cleaning solvents, a combustible detergent, or "**ALL** purpose" cleaner.  
**EXPLOSION COULD RESULT.**

**WARNING:** **DO NOT** dry rags or articles coated or contaminated with gasoline, kerosene, oil, paint, wax.  
**EXPLOSION COULD RESULT.**

**WARNING:** *DO NOT* dry mop heads. Contamination by wax or flammable solvents will create a fire hazard.

**WARNING:** *DO NOT* use heat for drying articles that contain plastic, foam, sponge rubber, or similarly textured rubber materials. Drying in a heated tumbler (basket) may damage plastics or rubber and also may be a fire hazard.

7. A program **should be** established for the inspection and cleaning of lint in the heating unit area, exhaust duct work, and inside the dryer. The frequency of inspection and cleaning can best be determined from experience at each location.

**WARNING:** The collection of lint in the burner area and exhaust duct work can create a potential fire hazard.

8. For personal safety, the dryer **must be** electrically grounded in accordance with local codes and/or the National Electrical Code ANSI/NFPA NO. 70-LATEST EDITION or in Canada, the Canadian Electrical Codes Parts 1 & 2 CSA C22.1-1990 or LATEST EDITION.

**NOTE:** Failure to do so will VOID THE WARRANTY.

9. UNDER NO CIRCUMSTANCES should the dryer door switches, lint door switch, heat safety circuit ever be disabled.

**WARNING: PERSONAL INJURY or FIRE COULD RESULT.**

10. This dryer is not to be used in the presence of dry cleaning solvents or fumes.
11. Remove articles from the dryer as soon as the drying cycle has been completed.

**WARNING:** Articles left in the dryer after the drying and cooling cycles have been completed can create a fire hazard.

12. **DO NOT** operate steam dryers with more than 125 PSI (8.61 bars) steam pressure. Excessive steam pressure can damage steam coil and/or harm personnel.
13. Replace leaking flexible hoses or other steam fixtures immediately. **DO NOT** operate the dryer with leaking flexible hoses. **PERSONAL INJURY MAY RESULT.**
14. **READ and FOLLOW ALL CAUTION and DIRECTION LABELS ATTACHED TO THE DRYER.**

**WARNING: YOU MUST DISCONNECT and LOCKOUT THE ELECTRIC SUPPLY and THE GAS SUPPLY or THE STEAM SUPPLY BEFORE ANY COVERS or GUARDS ARE REMOVED FROM THE MACHINE TO ALLOW ACCESS FOR CLEANING, ADJUSTING, INSTALLATION, or TESTING OF ANY EQUIPMENT per OSHA (Occupational Safety and Health Administration) STANDARDS.**



# SECTION II

## ROUTINE MAINTENANCE

### A. CLEANING

A program and/or schedule **should be** established for periodic inspection, cleaning, and removal of lint from various areas of the dryer, as well as throughout the duct work system. The frequency of cleaning can best be determined from experience at each location. Maximum operating efficiency is dependent upon proper air circulation. The accumulation of lint can restrict this airflow. If the guidelines in this section are met, an ADC dryer will provide many years of efficient, trouble free, and – most importantly – safe operation.

**WARNING: LINT FROM MOST FABRICS IS HIGHLY COMBUSTIBLE. THE ACCUMULATION OF LINT CAN CREATE A POTENTIAL FIRE HAZARD.**

**WARNING: KEEP DRYER AREA CLEAR and FREE FROM COMBUSTIBLE MATERIALS, GASOLINE, and THEIR FLAMMABLE VAPORS and LIQUIDS.**

**NOTE:** Suggested time intervals shown are for average usage which is considered six (6) to eight (8) operational (running) hours per day.

Clean lint drawer and screen every third or fourth load.

**NOTE:** Frequency can best be determined at each location.

#### *DAILY*

(beginning) of each work shift.

Clean lint from the lint drawer and screen. Inspect lint screen and replace if torn.

#### *WEEKLY*

Clean lint accumulation from lint chamber, thermostat, and microprocessor temperature sensor (sensor bracket) area.

**WARNING:** To avoid the hazard of electrical shock, discontinue electrical supply to dryer.

#### *STEAM DRYERS*

Clean steam coil fins using compressed air and a vacuum cleaner with brush attachment.

**NOTE:** When cleaning steam coil fins, be careful not to bend the fins. If fins are bent, straighten by using fin comb which is available from local air conditioning supply houses.

#### *90 DAYS*

Remove lint from tumbler (basket), drive motors, and surrounding areas. Remove lint from gas valve burner area with a dusting brush or vacuum cleaner attachment.

**NOTE:** To prevent damage, avoid cleaning, and/or touching ignitor and flame-probe assembly.

Remove lint accumulation from inside control box and at rear area behind control box.

### ***EVERY 6 MONTHS***

Inspect and remove lint accumulation in customer furnished exhaust duct work system and from dryer's internal exhaust ducting.

**WARNING: THE ACCUMULATION OF LINT IN THE EXHAUST DUCT WORK CAN CREATE A POTENTIAL FIRE HAZARD.**

**WARNING: DO NOT OBSTRUCT THE FLOW OF COMBUSTION and VENTILATION AIR. CHECK CUSTOMER FURNISHED BACK DRAFT DAMPER IN EXHAUST DUCT WORK. INSPECT and REMOVE ANY LINT ACCUMULATION WHICH CAN CAUSE DAMPER TO BIND or STICK.**

**NOTE:** A back draft damper that is sticking partially closed can result in slow drying and shut down of the heat circuit safety switches or thermostats.

**NOTE:** When cleaning dryer cabinet(s), avoid using harsh abrasives. A product intended for the cleaning of appliances is recommended.

## **B. ADJUSTMENTS**

### ***7 DAYS AFTER INSTALLATION and EVERY 6 MONTHS THEREAFTER***

Inspect bolts, nuts, screws, (bearing set screws), nonpermanent gas connections (unions, shut-off valves, orifices, and ground connections). Motor and drive belts **should be** examined. Cracked or seriously frayed belts **should be** replaced. Tighten loose V-belts when necessary. Complete operational check of controls and valves. Complete operational check of **ALL** safety devices (door switch, lint drawer switch, sail switch, burner and hi-limit thermostats).

## **C. LUBRICATION**

The motor bearings, idler bearings, and tumbler (basket) bearings are permanently lubricated.  
**NO LUBRICATION IS NECESSARY.**

The impellor (fan) shaft bearings should be lubricated every three (3) months.

# SECTION III

## INSTALLATION REQUIREMENTS

Installation **should be** performed by competent technicians in accordance with local and state codes. In the absence of these codes, the installation **must conform** to applicable American National Standards: National Fuel Gas Code ANSI.Z223.1-LATEST EDITION or National Electrical Code ANSI/NFPA No. 70-LATEST EDITION, or in Canada, the installation **must conform** to applicable Canadian Standards: CAN/CGA-B149.1-M91 (Natural Gas) or CAN/CGA-B149.2-M91 (L.P. Gas) or LATEST EDITION (for General Installation and Gas Plumbing) or Canadian Electrical Codes Parts 1 & 2 CSA C22.1-1990 or LATEST EDITION (for Electrical Connections).

### A. ENCLOSURE, AIR SUPPLY, and EXHAUST REQUIREMENTS

**NOTE:** The following information is very brief and general. For a detailed description, refer to the ML-130 Installation Manual (ADC Part No. 113002).

Bulkheads and partitions around the dryer **should be** made of noncombustible materials. Allowances **should be** made for the opening and closing of the control door and lint drawer. Also, allowances **should be** made in the rear for ease of maintenance. (Refer to appropriate installation manual for recommended distances and minimum allowances required.)

When the dryer is operating, it draws in room air, heats it, passes this air through the tumbler (basket), and exhausts it out of the building. Therefore, the room air **must be** continually replenished from the outdoors. If the make-up air is inadequate, drying time and drying efficiency will be adversely affected. Ignition problems and sail switch “fluttering” problems on gas dryers may result, and you also could have premature motor failure from overheating. The air supply **must be** given careful consideration to insure proper performance of each dryer.

**IMPORTANT:** Make-up air **must be** provided from a source free of dry cleaning fumes. Make-up air that is contaminated by dry cleaning fumes will result in irreparable damage to motors and other dryer components.

Exhaust duct work **should be** designed and installed by a competent technician. Improperly sized duct work will create excessive back pressure which will result in slow drying, increased use of energy, and shut down of the burner by the airflow (sail) switch, burner hi-limit or lint chamber hi-heat protector thermostat. (Refer to appropriate Installation Manual for more details.)

**CAUTION: IMPROPERLY SIZED or INSTALLED EXHAUST DUCT WORK CAN CREATE A POTENTIAL FIRE HAZARD.**

### B. ELECTRICAL and GAS REQUIREMENTS

It is your responsibility to have **ALL** electrical connections made by a properly licensed and competent electrician to assure that the electrical installation is adequate and conforms with local and state regulations or codes. In the absence of such codes, **ALL** electrical connections, material, and workmanship **must conform** to the applicable requirements of the National Electrical Code ANSI/NFPA No. 70-LATEST EDITION, or in Canada, the Canadian Electrical Codes Parts 1 & 2 CSA C22.1-1990 or LATEST EDITION (for Electrical Connections).

**IMPORTANT:** Failure to comply with these codes or ordinances and/or the requirements stipulated in this manual can result in personal injury or component failure.

The gas dryer installation **must meet** the American National Standard, National Fuel Gas Code ANSI Z223.1-LATEST EDITION, or in Canada, the Canadian Electrical Codes Parts 1 & 2 CSA C22.1-1990 or LATEST EDITION (for Electrical Connections) as well as, local codes and ordinances, and **must be** done by a qualified technician.

**NOTE:** Undersized gas piping will result in ignition problems and slow drying and can create a safety hazard.

The dryer **must be** connected to the type of gas (natural or L.P. [liquid propane]) indicated on the dryer data label. If this information ***DOES NOT agree with the type of gas available, contact the distributor who sold the dryer or contact the factory.***

The gas input ratings shown on the dryer data label are for elevations up to 2,000 feet (610 meters), unless elevation requirements of over 2,000 feet (610 meters) were specified at the time the dryer order was placed with the factory. The adjustment for dryers in the field for elevations over 2,000 feet (610 meters) are made by changing the burner orifices. If this adjustment is necessary, contact the distributor who sold the dryer or contact the factory.

**NOTE:** Any burner changes ***must be*** made by a qualified technician.

## C. OPERATIONAL SERVICE CHECK PROCEDURE

1. Turn on electric power to the dryer.
2. To start dryer:
  - a. Display will read "READY."
  - b. Press "E" on the keyboard (touchpad) of microprocessor controller (computer).
  - c. The dryer will start and the display will show "dr30."

**NOTE:** Pressing keyboard (touchpad) selections "A," "B," "C," "D," and "F" will also start the dryer. Six (6) preprogrammed drying cycles ("A" through "F") have been stored in the computer's memory. (Refer to the Computer Operator's Manual for details.)

3. Make a complete operational check of **ALL** the operating controls to assure that the timing is correct, temperature selection switches are functioning, etc.
4. Make a complete operational check of **ALL** safety-related circuits - door switch(es), hi-limit thermostat, sail switch, cycling thermostats, etc.
5. For gas dryers a gas pressure test **should be** taken at the gas valve pressure tap of each dryer to assure that the water column pressure is correct and consistent.

**NOTE:** Water column pressure requirements (measured at the pressure tap on the gas valve body):

Natural Gas - 3.5 inches water column (W.C.) - 8.7 mb.

L.P. Gas - 10.5 inches water column (W.C.) - 26.1 mb.

6. If computer program changes are required, refer to the Phase 6 OPL User's Manual (ADC Part No. 113022) for details.
7. The dryer **should be** operated through one complete cycle to assure that no further adjustments are necessary and that **ALL** components are functioning properly.
8. Check the electric service phase sequence. While the dryer is operating, check to see if the blower wheel is rotating in the proper direction. Looking from the front, the blower wheel **should spin** in the clockwise (CW) direction. If so, the phasing is correct. If the phasing is incorrect, reverse two (2) leads at connections L1, L2, or L3 of power supply to the dryer.

# SECTION IV

## DESCRIPTION OF PARTS

### A. CONTROL BOX

Lifting the control door and opening the computer panel will reveal the control box. Inside the control box are **ALL** the electronic control components. Located on the back of the control panel is the computer. Included in the control box are the 30-position block, fuse block, and transformer.

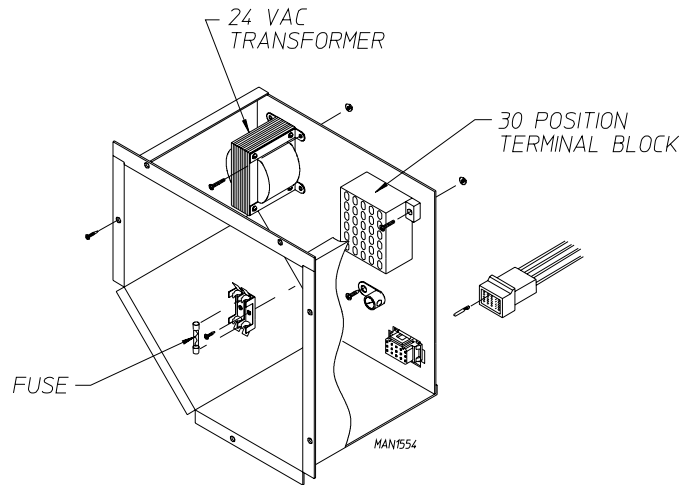

### B. DRIVE MOTOR

The T.E.F.C. (Totally Enclosed, Fan-Cooled) drive motor is located approximately lower center of the dryer. It sits on an adjustable base so that the motor can be easily adjusted to the left or right, up or down, forward or backward. The drive motor is a 3/4 HP motor and operates on 208 to 460 volts, 3-phase (3 $\phi$ ), 50/60 Hz.

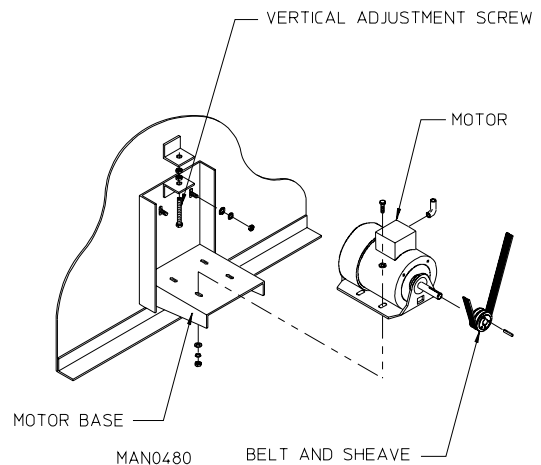

### C. HSI (HOT SURFACE IGNITION) MODULE (Gas Models Only)

The HSI (Hot Surface Ignition) system consists of a microprocessor (computer) based control module, along with a hot surface ignitor probe, and a flame probe assembly. The hot surface ignitor is a silicon carbide ignitor that upon application of 24 VAC will glow bright orange for the inter-purge time period. Upon ignition, the resistance in the flame sensor electrode changes and the information is sent to the HSI module via the sensor probe lead connection to the module. Once the resistance is changed and sensed, the HSI module will sustain the gas flow (provide 24 VAC power to the gas valve).

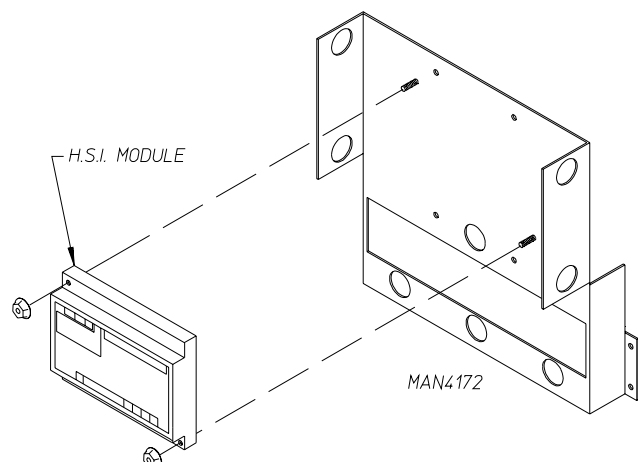

## D. GAS BURNER ASSEMBLY

Gas heated dryers are equipped with a gas burner assembly consisting of three (3) burner tubes, gas valve, glo bar, flame sensor, sail switch, and hi-limit thermostat. The inlet piping enters through the rear of the dryer on the left hand side (viewing from the front) and runs to the front of the dryer where the gas valve is located.

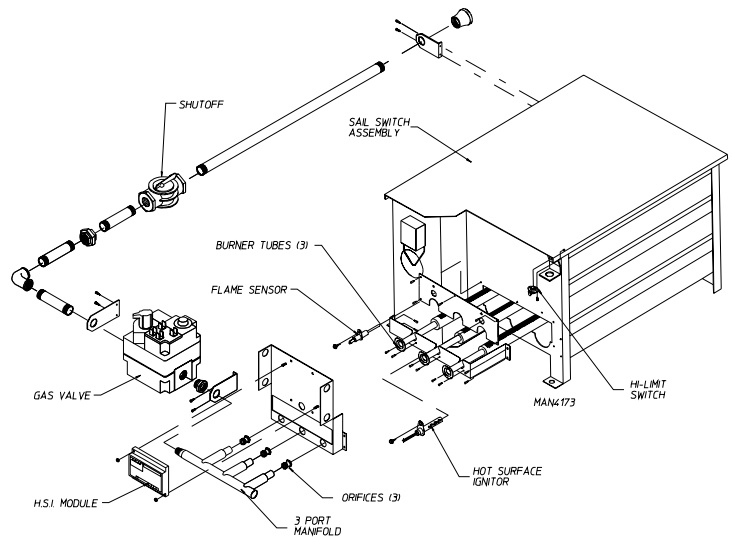

## E. BLOWER MOTOR and IMPELLOR

The impellor on the ML-130 is shaft driven. The blower motor drives the shaft on which the impellor is mounted. This enables the impellor to run at a higher RPM, thereby producing a higher airflow (cfm).

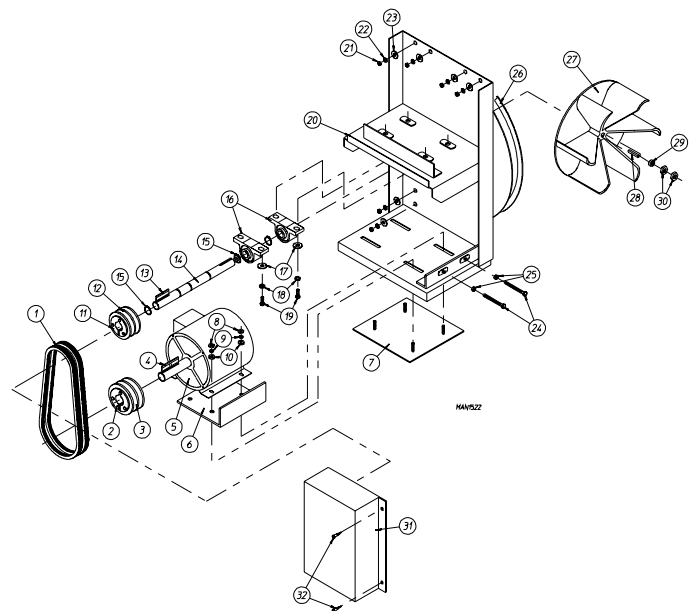

## F. IDLER ASSEMBLY

(Viewing from the rear of the dryer) the idler assembly is located approximately on the lower center of the dryer. The idler assembly consists of two (2) idler pulleys, (small and large). The idlers' main purpose is to reduce the speed and increase torque provided to the tumbler (basket) bearing. Also, at the idler assembly, belt tension can be adjusted.

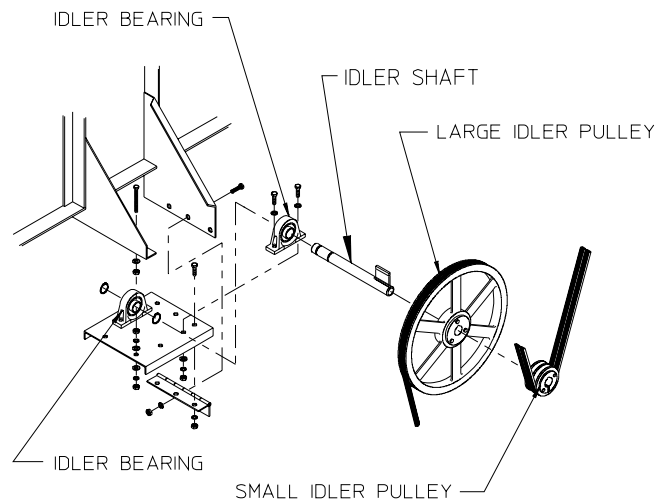

MAN0481

## G. TUMBLER (BASKET) BEARING and PULLEY ARRANGEMENT

The tumbler (basket) bearing and pulley arrangement is located (viewing from the rear of the dryer) approximately at the upper center of the dryer. The arrangement consists of a pulley and two (2) bearings which serve to drive, adjust, and support the tumbler (basket).

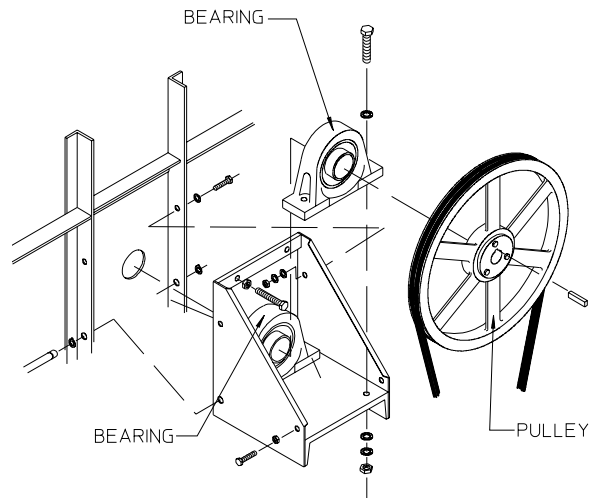

MAN0536

## H. TUMBLER (BASKET)

The tumbler (basket) consists of four (4) ribs and four (4) perforated panels, along with a front and back, which are screwed together as an assembly. The tumbler (basket) also consists of tie rods, which support the tumbler (basket) from front to back. The tumbler (basket) support is used to mate the tumbler (basket) to the drive system in the rear.

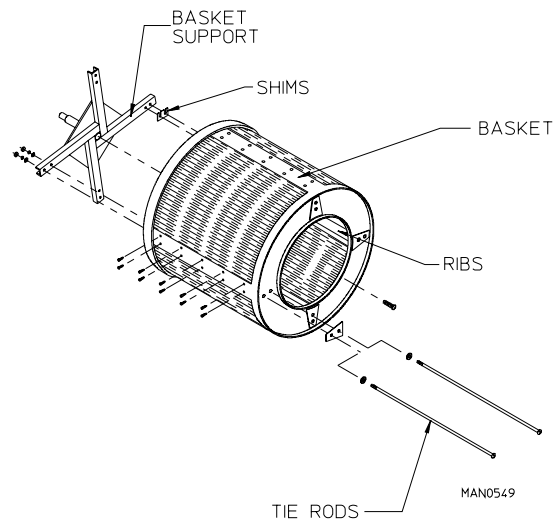

MAN0549

## I. MAIN DOOR SWITCH

The main door switch is mounted to the front panel behind the main door. When the main door opens, the switch will also open, preventing the dryer from operating. **The main door switch is a safety device and should never be disabled.**

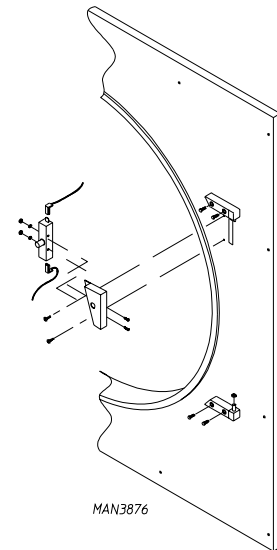

MAN3876

CURRENT PRODUCTION



## J. SAIL SWITCH (Gas and Electric Models Only)

The sail switch is located on the front of the burner box for gas dryers on the right side of the oven assembly for electric dryers. A sail switch consists of a round damper plate on a lever arm which is in contact with an electric switch. When the air blower comes on, it draws air through the gas or electric burner. This creates a negative pressure inside the burner box, and this negative pressure pulls in the round damper and activates the sail switch. If there is improper airflow, the damper will not pull in, preventing the burner from coming on. Improper airflow can be caused by improperly designed exhaust ducting where the duct run is too long or has too many sharp bends in it. It can also be caused by a lack of make-up air.

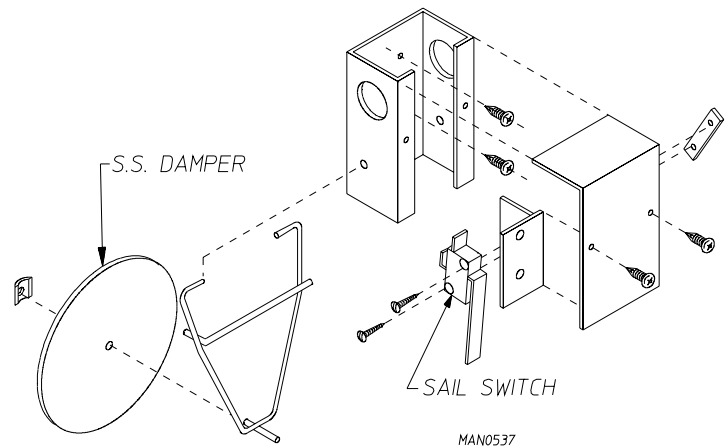

## K. HI-LIMIT (Gas and Electric Models Only)

A hi-limit thermostat is located at the burner. This is a manual reset disc-type thermostat set at 330° F (166° C) for gas dryers and at 290° F (143° C) for electric dryers. If the flame in the burner should get too hot, this thermostat will shut off the burner. This is generally caused by low airflow through the dryer.

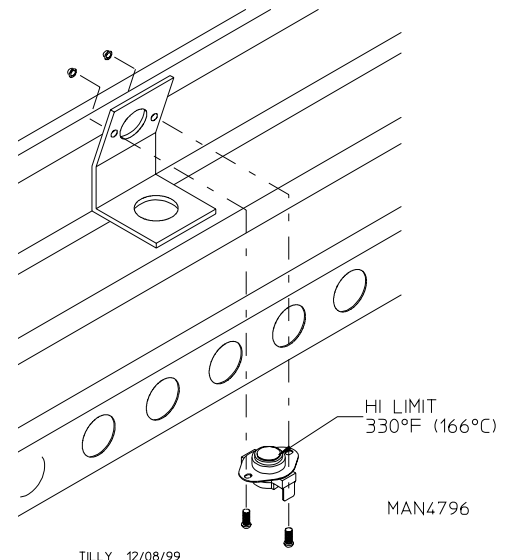

## L. MANUAL RESET THERMOSTAT

This is located inside the dryer in the lint compartment above the lint screen. This thermostat senses the heated air after it passes through the tumbler (basket). If the air temperature gets too hot, the thermostat will shut off the burner. The dryer will not run until the air temperature cools down. At this time, the manual reset thermostat **must be** reset manually or the 24 VAC burner circuit will never be completed. Tumbler (Basket) and blower will run but the dryer will not heat. If the temperature sensor opens the display will read "TEMP SENSOR FAIL CHECK TEMP SENSOR FUSE" with an audio indication. If the thermostat opens the display will read "DRUM SAFETY FAIL" with an audio indication.

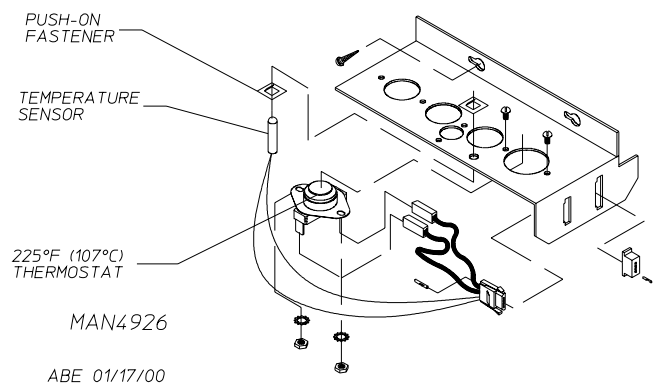

## M. LINT DRAWER

The lint drawer is a pull-out type and is located at the bottom of the dryer in the lint compartment. Simply grab the lint drawer handle, slide out the drawer, brush off the lint, and slide the drawer back in. The lint screen **must be** kept clean in order for the dryer to operate properly and efficiently.

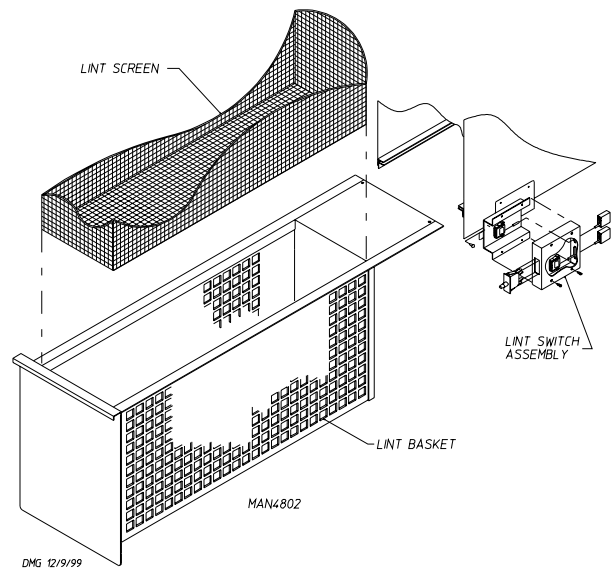

## N. LINT DRAWER SWITCH

The lint drawer switch is located in the lint compartment and attached to the side of the lint drawer track. The lint drawer switch insures that the dryer will operate only when the lint drawer is completely closed. This is a safety device and **should never be** disabled.

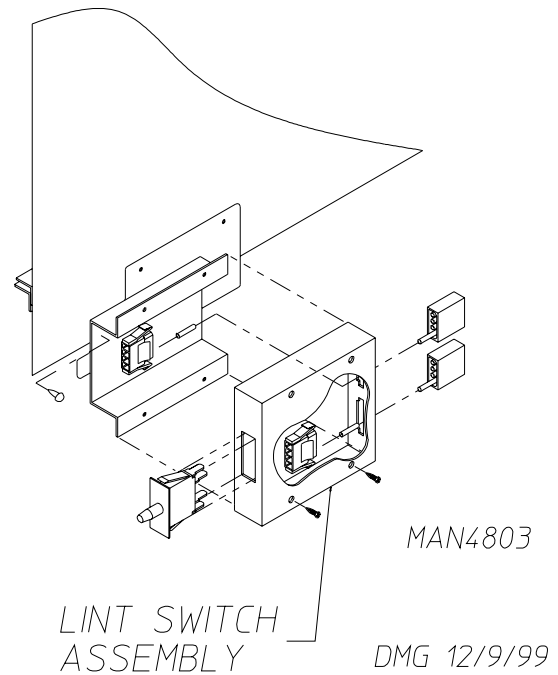

## O. STEAM DAMPER SYSTEM

The newest type system is called the steam damper. It is shown to the right and it uses a piston with compressed air to open and close the steam damper which in turn allows the air to flow either through the coil for heat, or under the coil for cool down. Air supply is 80 PSI +/- 10 PSI (5.51 bars +/- 0.69 bars).

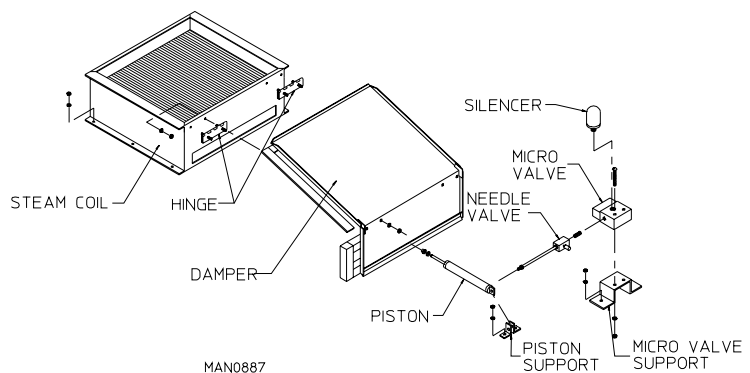

# SECTION V

## SERVICING

### INTRODUCTION

**ALL** electrical and mechanical service or repairs **should be** made with the electrical power to the dryer disconnected (power off).

**WARNING: PERSONAL INJURY COULD RESULT.**

The information provided in this section **should not be** misconstrued as a device for use by an untrained person making repairs. Service work **should be** performed by competent technicians in accordance with local, state, and federal codes. When contacting the factory for assistance, always have the dryer model and serial numbers available.

**CAUTION:** Observe **ALL** safety precautions displayed on the dryer or specified in this manual before and while making repairs.

Before considering replacement, make sure that **ALL** connectors are in place and making proper contact.

### A. COMPUTER CONTROLS

#### To Replace Computer Control Panel

1. Discontinue electrical power to the dryer.
2. Disconnect main power harness from rear of computer by squeezing locking tabs and pulling connector straight back.
3. Disconnect the “green” ground wire from the computer.
4. To remove control panel assembly from control box, gently tap the bottom of the control panel upward and lift off the hinges.
5. Install new control panel assembly by reversing this procedure.
6. When replacing the computer, the “A” and “B” factors **must be** reprogrammed. (refer to Phase 6 OPL User’s Manual [ADC Part No. 113022].)

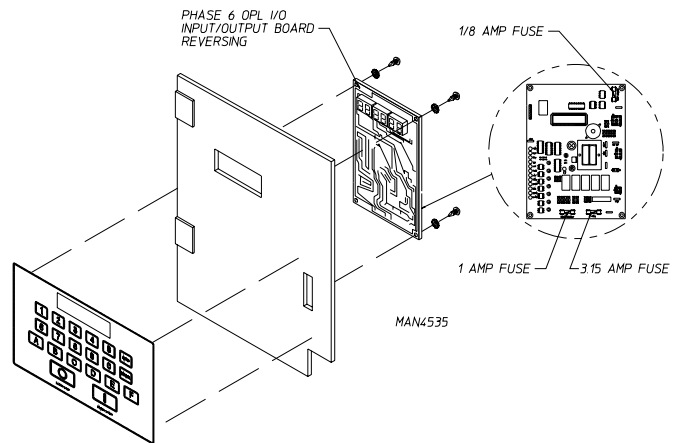

**NOTE:** The “A” and “B” factors are printed on a label located on the rear of the control panel. (refer to illustration above.)

7. Reestablish electrical power to the dryer.

## To Replace Computer

1. Disconnect electrical power to the dryer.
2. Disconnect main power harness from rear of computer by squeezing locking tab and pulling connector straight back.
3. Disconnect the “green” ground wire from the computer.
4. Disconnect keyboard (touchpad) ribbon from computer.
5. Remove the two (2) hex nuts securing the computer to the sheet metal control panel. Remove the board by pulling the other two (2) corners off the clinch studs.
6. Install new computer by reversing this procedure. (refer to illustration on **page 15**.)
7. When replacing the computer, the “A” and “B” factors **must be** reprogrammed. (refer to Phase 6 OPL User’s Manual [ADC Part No. 113022].)

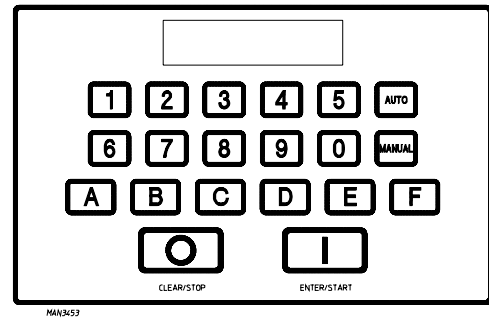

**NOTE:** The “A” and “B” factors are printed on a label located on the rear of the control panel (refer to illustration).

8. Reestablish electrical power to the dryer.

## To Replace Keyboard (Touchpad) Label Assembly

1. Discontinue electrical power to the dryer.
2. Unplug keyboard (touchpad) ribbon from rear of the microprocessor computer.
3. Slowly peel off and remove keyboard (touchpad) label assembly from control panel.
4. Peel paper backing off new keyboard (touchpad) label assembly.
5. Holding the new keyboard (touchpad) label assembly close to the control panel, insert the keyboard (touchpad) ribbon through the rectangular slot in the control panel. Align label assembly into position by matching the red viewing window on the label to the rectangular cutout in the panel and gently press into place.
6. Connect keyboard (touchpad) ribbon to the computer.
7. Reestablish electrical power to the dryer.

## To Replace Microprocessor Temperature Sensor Probe

1. Discontinue electrical power to the dryer.
2. Remove lint drawer.
3. Remove microprocessor sensor bracket assembly from dryer.
  - a. Disconnect sensor bracket harness connector.

- b. Loosen the two (2) Phillips head screws securing bracket assembly to dryer and remove bracket from dryer.

**NOTE: DO NOT** remove screws.

4. Disassemble sensor probe from bracket assembly by removing the top push-on fastener securing the probe to the bracket. Use a small screwdriver to slowly pry the fastener off.
5. Disconnect the two (2) “orange” wires from the high heat (225° F [107° C]) thermostat, and remove modular bracket connector, wires, and probe from bracket assembly.
6. Install new sensor probe assembly (ADC Part No. 880251) by reversing procedure.
7. Reestablish electrical power to the dryer.

**NOTE:** If, when electrical power is reestablished, the computer display reads “dSFL,” check for a loose connection in the wiring.

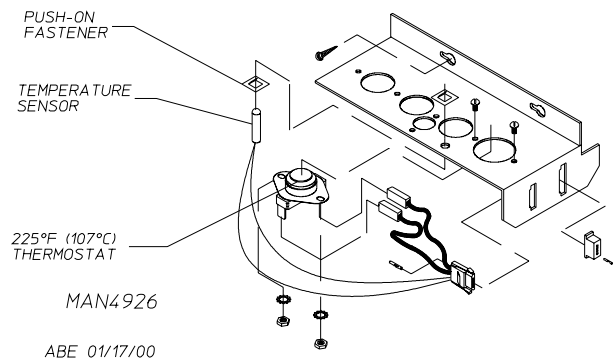

## B. IGNITION CONTROLS

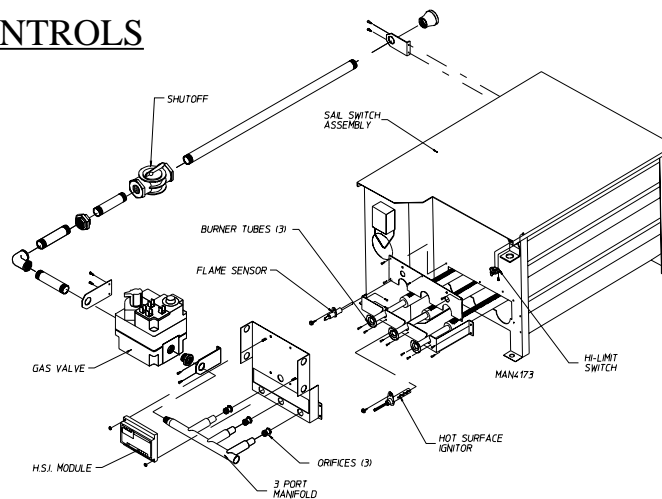

### To Remove Hot Surface Ignitor (refer to illustration above)

1. Discontinue electrical power to the dryer.
2. Disconnect wire from S1 and GND on the HSI (Hot Surface Ignition) module.
3. Disassemble ignitor from burner by removing the one (1) self tapping screw.
4. Reverse procedure for installation of new ignitor.

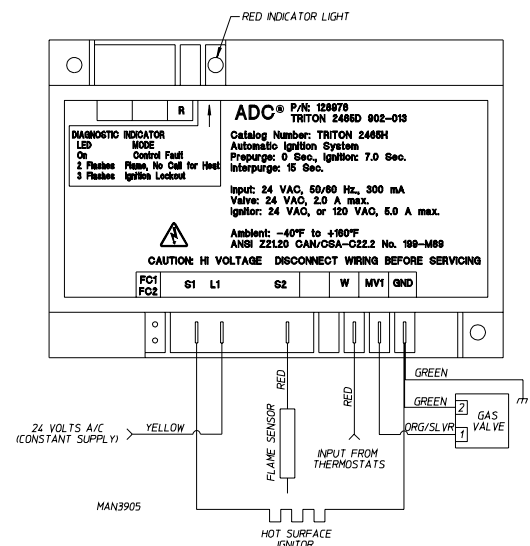

**NOTE:** Before reestablishing electrical power to the dryer visually check the following (refer to illustration above).

5. Reestablish procedure for installation of new ignitor.

### To Remove Flame Sensor Probe

1. Discontinue electrical power to the dryer.
2. Disconnect the “red” wire from the flame sensor probe which goes to S2 on the HSI (Hot Surface Ignition) module.
3. Disassemble flame sensor probe from burner by removing the one (1) self tapping screw.
4. Reverse procedure for installation of new flame sensor probe.

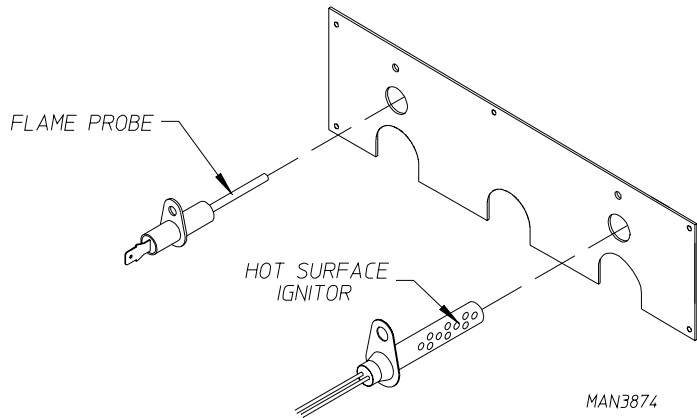

**NOTE:** Before reestablishing electrical power to the dryer visually check the following (refer to illustration above).

5. Reestablish procedure for installation of new ignitor.

### HSI Ignitor Flame Sensor Probe

1. Disconnect electrical power to the dryer.
2. Disconnect the hot surface ignitor wires S1 and ground (GND) on the HSI (Hot Surface Ignition) Module.
3. Disassemble Hot Surface Ignitor Probe from the burner by removing the one (1) self tapping screw.
4. Reverse procedure for installation of new hot surface ignitor.

**NOTE:** Before reestablishing electrical power to the dryer visually check the following (refer to illustration above).

**NOTE: DO NOT WRAP THE HOT SURFACE IGNITOR WIRES AND THE FLAME ELECTRODE WIRE TOGETHER. IMPROPER OPERATION MAY RESULT. THEY MAY RUN ALONGSIDE EACH OTHER.**

5. Reestablish procedure for installation of new ignitor.

### To Replace Gas Valve (Refer to burner illustration on previous page [page 17].)

1. Discontinue electrical power to the dryer.
2. Close shut-off valve(s) in gas supply line.
3. Disconnect gas valve wiring.

**NOTE:** Identify location of each wire for correct reinstallation.

4. Break union connection before gas valve.
5. Loosen and remove four (4) screws securing pipe brackets to burner.
6. Remove gas valve and manifold assembly from dryer.
7. Remove valve mounting bracket, manifold, and piping from gas valve.
8. Reverse procedure for installing new gas valve.

**WARNING:** Test **ALL** connections for leaks by brushing on a soapy water solution.

**WARNING: NEVER TEST FOR LEAKS WITH A FLAME!!!**

### To Replace Main Burner Orifices

1. Refer to “To Replace Gas Valve” and follow *Step #1 through Step #6*.
2. Unscrew main burner orifices and replace.

**NOTE:** Use extreme care when removing and replacing orifices. These orifices are made of brass and are easily damaged.

3. Reversing the removal procedure for reinstalling.

**WARNING:** Test **ALL** connections for leaks by brushing on a soapy water solution.

**WARNING: NEVER TEST FOR LEAKS WITH A FLAME!!!**

### To Test and Adjust Gas (Water Column) Pressure

There are two (2) types of devices commonly used to measure water column pressure. They are spring and mechanical-type gauges and manometers. The spring and mechanical-type gauge is not recommended, because it is easily damaged and not always accurate. A manometer is simply a glass or transparent plastic tube with a scale in inches. When filled with water and pressure applied, the water in the tube rises showing the exact water column pressure.

**NOTE:** Manometers are available from the factory by ordering **ADC Part No. 122804**.

1. To Test Gas Water Column (W.C.) Pressure:
  - a. Connect water column test gauge connection to gas valve pressure tap (1/8” NPT). This pressure tap is located on the outlet (manifold) side of the valve.
  - b. Start dryer. With burner on, the correct water column reading in inches would be:

Natural Gas - 3.5 Inches Water Column (8.7 mb).

L.P. Gas - 10.5 Inches Water Column (26.1 mb).

2. To Adjust Water Column Pressure (natural gas only, L.P. gas **must be** regulated at source):
  - a. Remove the slotted vent cap on the top of the valve.
  - b. Turn the slotted adjustment screw located on top of the valve next to the terminals. Turn clockwise (CW) to increase manifold pressure and counterclockwise (CCW) to decrease.

**NOTE:** If correct W.C. pressure **cannot** be achieved, problem may be due to an undersized gas supply line, a faulty or underrated gas meter, etc.

### To Convert from Natural Gas to L.P. Gas

**NOTE:** **ALL** dryers are sold as natural gas, unless otherwise specified at the time the dryer order was placed. For L.P. gas the dryer **must be** converted as follows.

Parts required for conversion: L.P. Kit P/N 881868. (For butane gas or elevations over 2,000 feet [609.6 meters], contact factory.)

1. Refer to “To Replace Gas Valve” and follow **Step #1 through Step #6**.
  - a. For models with 3/4” White-Rodgers valve.
    - 1) Remove top vent cap.
    - 2) Insert spring and pin.
    - 3) Replace vent cap.
2. Unscrew main burner orifices and replace with L.P. orifices.

**NOTE:** Use extreme care when removing and replacing orifices. These orifices are made of brass and are easily damaged.

3. Reverse the procedure for reinstalling valve assembly to the dryer.

**WARNING:** Test **ALL** connections for leaks by brushing on a soapy water solution.

**WARNING:** **NEVER TEST FOR LEAKS WITH A FLAME!!!**

**NOTE:** There is no regulator provided in an L.P. dryer. The column pressure **must be** regulated at the source (L.P. tank) or an external regulator **must be** added to each dryer.

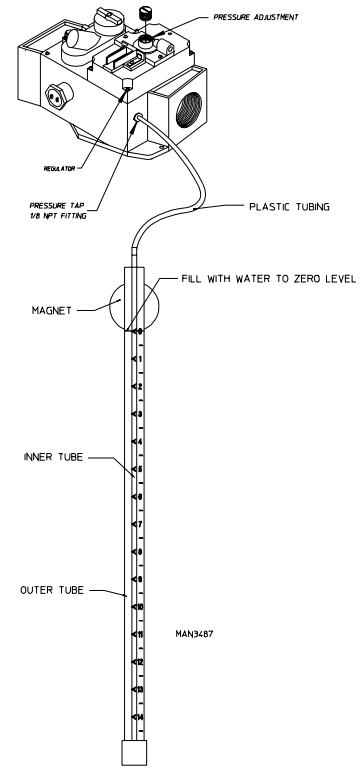



## To Replace Burner Tubes

1. Refer to “To Replace Gas Valve” and follow *Step #1 through Step #6*.
2. Remove four (4) screws securing manifold rest and remove rest.
3. Remove the screws securing the front flanges of the burner tubes to the burner tube rest.
4. Remove the screws securing the burner tube rest to the oven and remove this rest.
5. Remove screws securing the sight hole disk and burner box cover plate to the oven and remove both of these pieces.
6. Remove burner tubes by sliding them out.
7. Replace by reversing procedure.

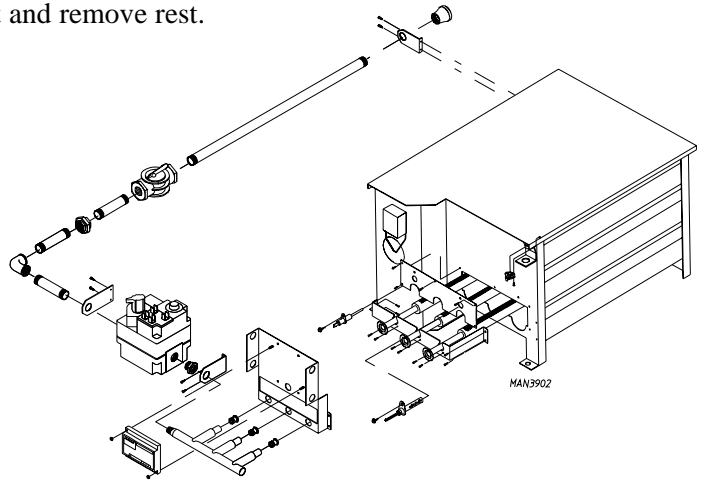

**WARNING:** Test ALL connections for leaks by brushing on a soapy water solution.

**WARNING:** NEVER TEST FOR LEAKS WITH A FLAME!!!

## To Replace HSI (Hot Surface Ignition) Module

1. Discontinue electrical power to the dryer.
2. Remove the wires connected to the terminal strip at the bottom of the module. (Mark correct location of each wire to aid in replacement on new module.)
3. Remove the four (4) pal nuts securing the module to the mounting bracket.
4. Replace module by reversing procedure. (refer to illustration on **page 17** for proper wire locations.)
5. Reestablish electrical power to the dryer.

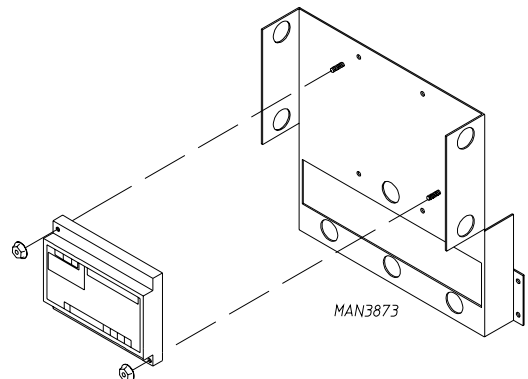

## C. THERMOSTATS

### To Replace Manual Reset Burner Hi-Limit (330° F [166° C]) Thermostat (Gas Models Only)

1. This thermostat is an important safety device as an added protection against failure of the airflow (sail switch) to open in the event of motor failure or reduced airflow conditions.

**IMPORTANT:** UNDER NO CIRCUMSTANCES should heat circuit safety devices ever be disabled.

**NOTE:** Models manufactured as of 1998 are equipped with a manual reset hi-limit thermostat.

1. Discontinue electrical power to the dryer.
2. Disconnect wires from hi-limit thermostat.
3. Remove the two (2) screws, washers, and nuts securing thermostat to the bracket. Remove thermostat.
4. Reversing procedure for installing new thermostat.
5. Reestablish electrical power to the dryer.

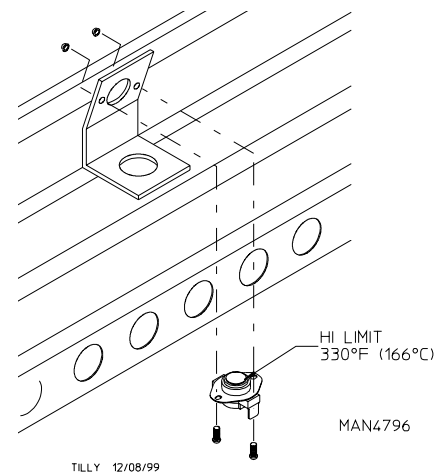

### To Replace Manual Reset Tumbler Hi-Heat Protector (225° F [107° C]) Thermostat

This thermostat is part of the “sensor bracket assembly” and is secured to the underside of the tumbler (basket) wrapper in the lint compartment. As a safety device, this thermostat will open (shut off) the heating unit circuit if an excessive temperature occurs. The dryer motor will remain on, even if the thermostat is open.

**IMPORTANT:** UNDER NO CIRCUMSTANCES should heat safety devices be disabled.

1. Disconnect electrical power to the dryer.
2. Remove lint drawer. Remove two (2) screws securing lint door and remove lint door.
3. Locate sensor bracket assembly and loosen the two (2) Phillips head screws securing bracket assembly to the tumbler (basket) wrapper.

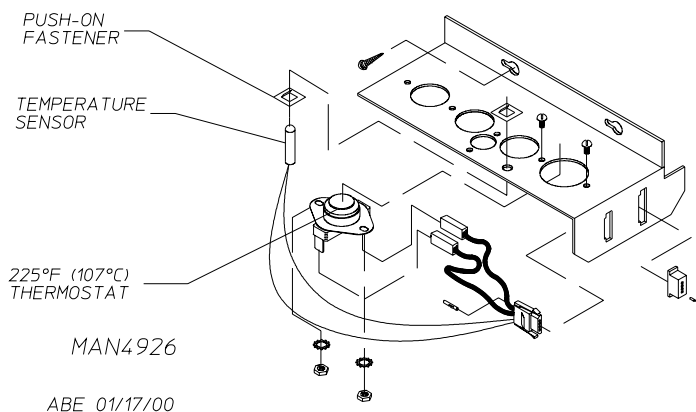

**NOTE:** *DO NOT* remove the screws.

4. Remove bracket assembly by slightly sliding bracket towards the rear of the dryer and to the left.
5. Disconnect sensor bracket harness connector and remove bracket assembly from dryer.
6. Disconnect the two (2) “orange” wires from thermostat.
7. Disassemble thermostat from bracket assembly by removing the two (2) mounting screws, washers, and nuts.
8. Reverse this procedure for installing a hi-heat protector thermostat.
9. Reestablish electrical power to the dryer.

## D. SAIL SWITCH ASSEMBLY (Gas and Electric Models Only)

The sail switch is a heat circuit safety device which controls the burner circuit only. When the dryer is operating and there is proper airflow, the sail switch damper pulls in and closes the sail switch. Providing **ALL** the other heat-related circuits are functioning properly, ignition **should now be** established. If an improper airflow occurs, the sail switch damper will release, and the circuit will open.

### To Replace Sail Switch

1. Discontinue electrical power to the dryer.
2. Remove the two (2) screws which hold the sail switch box cover to sail switch box.
3. Disconnect the two (2) wires from the switch.
4. Disassemble sail switch from mounting bracket by removing the two (2) screws securing switch in place.

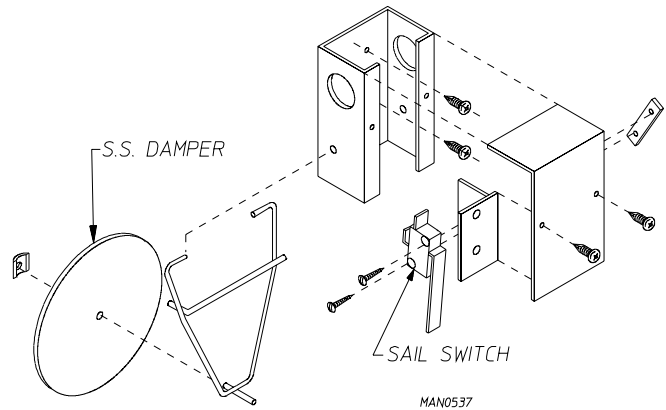

5. Reverse this procedure for installing new sail switch. Adjust sail switch as described in the next section.

### To Adjust Sail Switch

With the dryer operating at a high temperature setting, pull the sail switch damper away from the burner. The sail switch should open and extinguish the burner. The dryer will continue to run for three (3) minutes or until 100° F (38° C) is reached. The computer will display **no airflow**. If the sail switch circuit does not operate as described, bend the actuator arm of the sail switch accordingly until proper operation is achieved. To check proper “open” position of sail switch, open main door, manually depress main door switch, and start dryer. With the main door open and the dryer operating, the sail switch circuit **should be** open, and the burner should not come on. The computer will display **no airflow**.

**CAUTION: DO NOT** abort this switch by taping or screwing sail switch damper to burner.  
**PERSONAL INJURY or FIRE COULD RESULT.**

## E. FRONT PANEL and MAIN DOOR ASSEMBLIES

### To Replace Main Door Switch

1. Discontinue electrical power to the dryer.
2. Open main door.
3. Remove the two (2) Phillips head screws holding the main door switch bracket assembly in place.
4. Disconnect wiring from switch assembly.
5. Remove the two (2) screws which secure the switch to the housing.

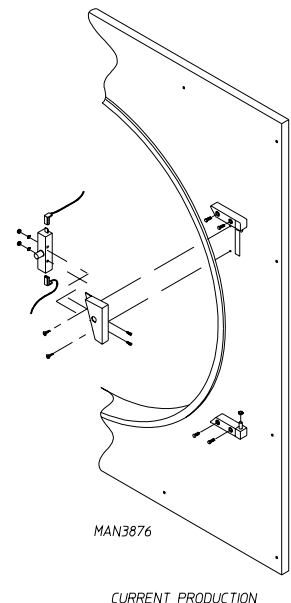

- Reverse this procedure for installing new door switch assembly.
- Reestablish electrical power to the dryer.

**IMPORTANT: UNDER NO CIRCUMSTANCES** should the door switch be disabled.

### To Replace Main Door Assembly

- Open main door.
- Holding the door upward remove the two (2) screws from the top hinge block.
- Lift the door up to remove.
- Reverse this procedure for reinstalling new main door assembly.

### To Install New Main Door Glass

- Remove main door assembly from dryer (follow main door removal procedure).
- Lay main door on flat surface with the back of the door facing down.
- Remove the four (4) #10-32 acorn nuts securing the glass to the door.

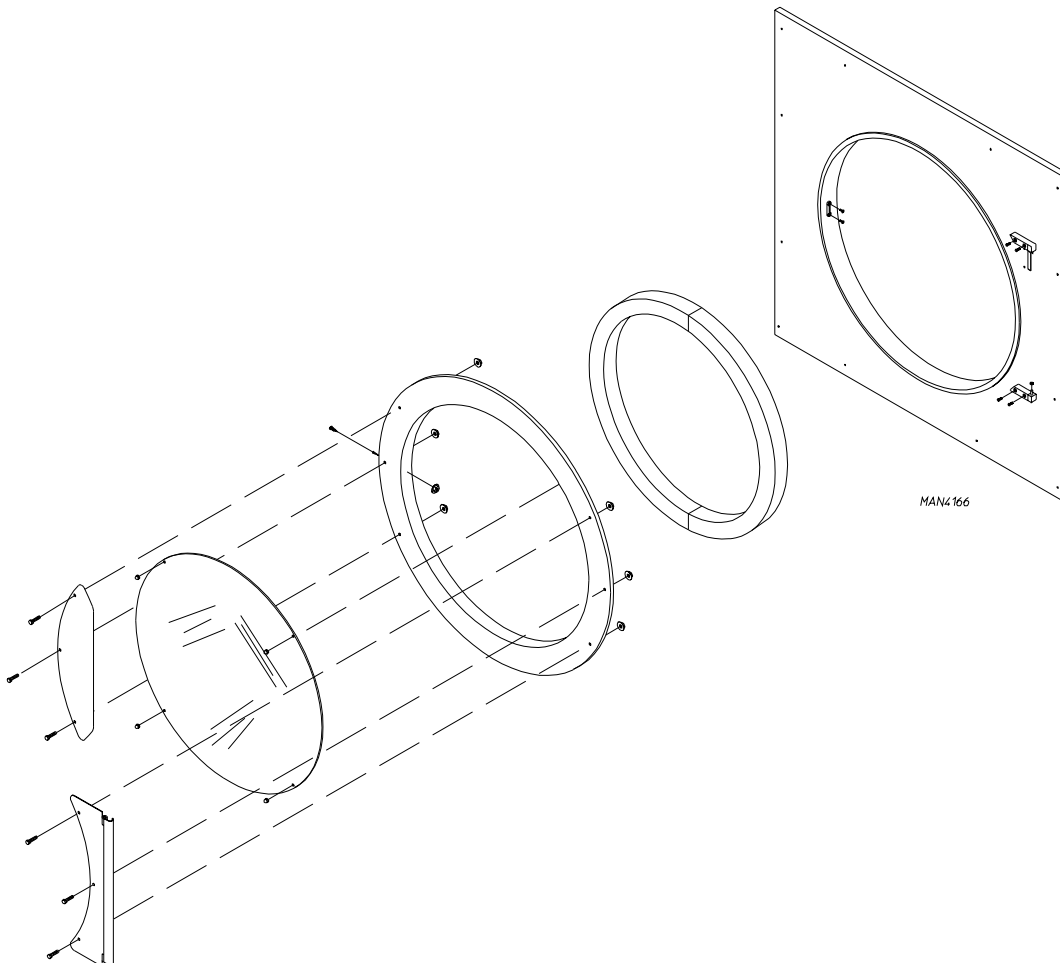

4. Remove glass and clean **ALL** old sealant off main door. This area **must be** clean for correct bonding.
5. Place a bead of silicone (ADC P/N 170730) around the edge door and lightly press glass into place.
6. Reinstall the four (4) #10-32 acorn nuts that were removed in *Step #3*.

**IMPORTANT:** *DO NOT* press hard or the silicone thickness between the glass and door **will be** reduced, resulting in poor bonding.

7. The door assembly **should now be** put in an area where it will not be disturbed for at least 24 hours. Depending on the conditions, the curing time of this adhesive is 24 to 36 hours.
8. After the curing period, install main door on dryer by reversing *Step #1*.

### To Replace Front Panel

1. Discontinue electrical power to the dryer.
2. Remove bottom lint drawer assembly.
3. Remove the screws securing the front panel to the dryer.
4. Disconnect the two (2) door switch wires located behind the front panel.
5. Remove the front panel.

**IMPORTANT:** When pulling the front panel off, the door switch harness in the upper right hand corner **must be** unplugged.

**NOTE:** The main door assembly can be removed to make the panel removal easier. Refer to “To Replace Main Door Assembly” directions.

6. Reinstall the new front panel by reversing *Step #1 through Step #4*.
7. Reestablish electrical power to the dryer.

### To Replace Main Door Hinge Block

1. Discontinue electrical power to the dryer.
2. Follow procedure for removal of main door assembly for top hinge removal.
3. Remove the two (2) screws from the bottom hinge block.
4. Reassemble by reversing removal procedure.
5. Reestablish electrical power to the dryer.

## F. PULLEYS

### To Replace Tumbler (Basket) Pulley

1. Loosen V-belts. Rotate pulley and roll V-belts out of grooves.
2. Remove cap screws from the bushing.
3. Insert cap screws in tapped removal holes and tighten evenly until bushing becomes loose on shaft. Refer to figure "A."
4. Remove bushing, pulley, and key.
5. Assemble bushing and sheave as shown in figure "B." When cap screws are loosely inserted, bushing remains fully expanded to provide a sliding fit on the shaft.
6. Insert key on the shaft, then slide sheave to desired position with cap screw heads to the outside.
7. Tighten cap screws progressively. There should remain a gap between the sheave hub and the flange of the bushing.

**IMPORTANT:** Tighten screws evenly and progressively. Never allow the sheave to be drawn in contact with the flange of the bushing. This gap should measure from 1/8" to 1/4". Proper cap screw torque is 30 ft-lbs. (41 Nm). If greater tightening forces are applied, excess pressures **will be** created in the hub of the mounted sheave which may cause it to crack.

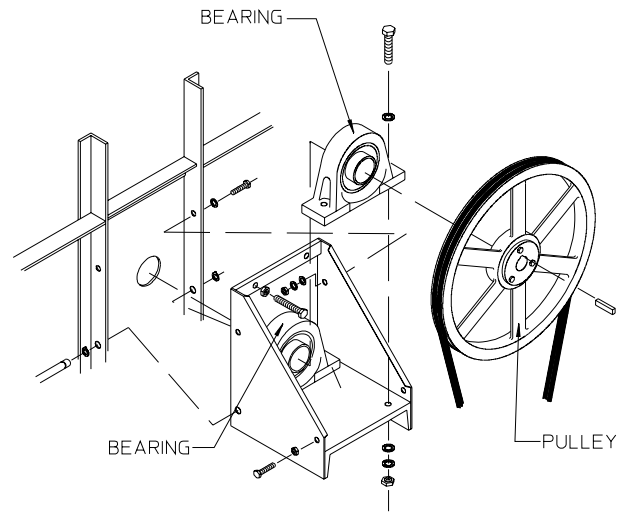

MAN0536

# A

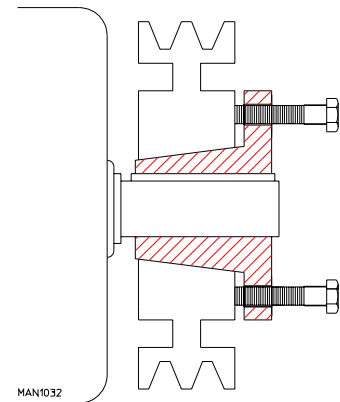

### To Replace Small Idler Pulley

1. Loosen V-belts. Rotate pulley and roll V-belts out of grooves.
2. Remove cap screws from the bushing.
3. Insert cap screws in tapped removal holes and tighten evenly until bushing becomes loose on shaft. Refer to figure "A."
4. Remove bushing, pulley, and key.
5. Assemble bushing and sheave as shown in figure "B." When cap screws are loosely inserted, bushing remains fully expanded to provide a sliding fit on the shaft.
6. Insert key on the shaft, then slide sheave to desired position with cap screw heads to the outside.

# B

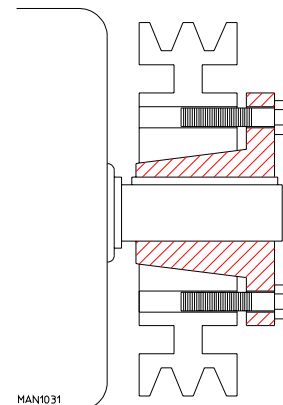

- Tighten cap screws progressively. There should remain a gap between the sheave hub and the flange of the bushing.

**IMPORTANT:** Tighten screws evenly and progressively. Never allow the sheave to be drawn in contact with the flange of the bushing. This gap should measure from 1/8" to 1/4". Proper cap screw torque is 6 ft-lbs. (8 Nm), if greater tightening forces are applied, excess pressures **will be** created in the hub of the mounted sheave which may cause it to crack.

### To Replace Large Idler Pulley

- Loosen V-belts. Then, rotate pulley and roll V-belts out of grooves.
- Remove cap screws.
- Insert cap screws in tapped removal holes and tighten evenly until bushing becomes loose on shaft. Refer to figure "A" on previous page.
- Remove bushing, pulley, and key.

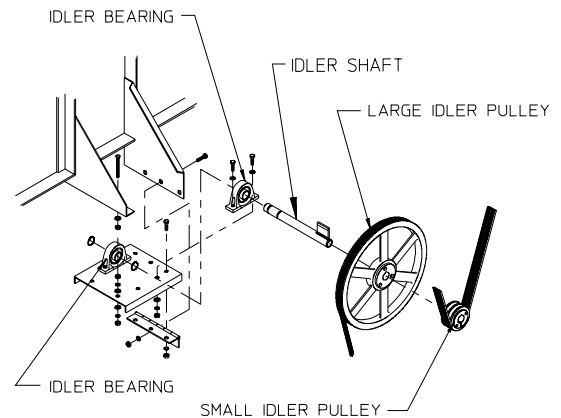

MAN0481

- Assemble bushing and sheave as shown in figure "B" on previous page (page 26). When cap screws are loosely inserted, bushing remains fully expanded to provide a sliding fit on the shaft.
- Insert key on the shaft, then slide sheave to desired position with cap screw heads to the outside.
- Tighten cap screws progressively. There should remain a gap between the sheave hub and the flange of the bushing.

**IMPORTANT:** Tighten screws evenly and progressively. Never allow the sheave to be drawn in contact with the flange of the bushing. This gap should measure from 1/8" to 1/4". Proper cap screw torque is 15 ft-lbs. (20 Nm). If greater tightening forces are applied, excess pressures **will be** created in the hub of the mounted sheave which may cause it to crack.

### To Replace Motor Pulley

- Loosen V-belts. Rotate pulley and roll V-belts out of grooves.
- Remove cap screws from bushing.
- Insert cap screws in tapped removal holes and tighten evenly until bushing becomes loose on shaft. Refer to figure "A" on previous page.
- Remove bushing, pulley, and key.

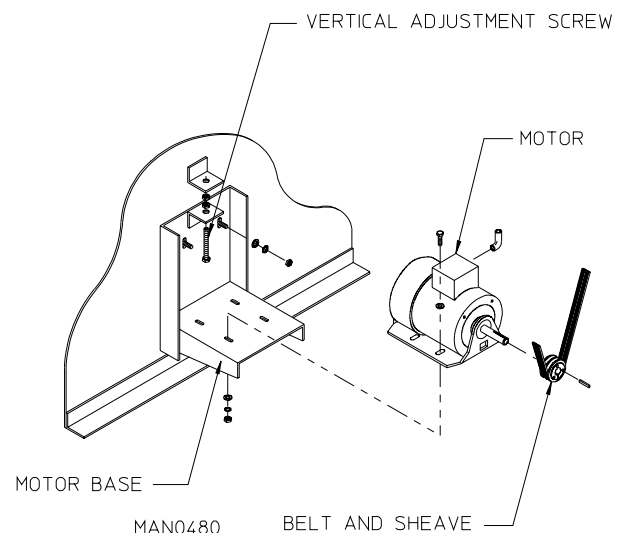

MAN0480

5. Assemble bushing and sheave as shown in figure “B” on **page 26**. When cap screws are loosely inserted, bushing remains fully expanded to provide a sliding fit on the shaft.
6. Insert key on the shaft, then slide sheave to desired position with cap screw heads to the outside.
7. Tighten cap screws progressively. There should remain a gap between the sheave hub and the flange of the bushing.

**IMPORTANT:** Tighten screws evenly and progressively. Never allow the sheave to be drawn in contact with the flange of the bushing. This gap should measure from 1/8” to 1/4”. Proper cap screw torque is 6 ft-lbs., (8 Nm). If greater tightening forces are applied, excess pressures **will be** created in the hub of the mounted sheave which may cause it to crack.

## G. TUMBLER (BASKET) ASSEMBLY

### Tumbler (Basket) Alignment (Vertical) (Up and Down Adjustment)

1. Discontinue electrical power to the dryer.
2. Remove back guard.
3. Loosen the two (2) vertical holding bolts on the sides at the top of the bearing box. (One [1] on each side).
4. Back off jam nuts on vertical adjustment bolts.
5. Turn these bolts clockwise (CW) evenly to raise tumbler (basket) or counterclockwise (CCW) evenly to lower tumbler (basket).
6. Rotate tumbler (basket) from front and check alignment with front door opening.
7. Leave a larger gap from the inside ring on the top of the front panel opening to the tumbler (basket) and a smaller gap on the bottom to compensate for the weight of the clothes when wet.
8. Retighten the two (2) vertical holding bolts on the sides, at the top of the bearing box, and the jam nuts on the two (2) vertical adjustment bolts.
9. Check tumbler (basket) drive belt for proper tension. Adjust if necessary. (Refer to Section I, page 32.)
10. Replace back guard.
11. Reestablish electrical power to the dryer.

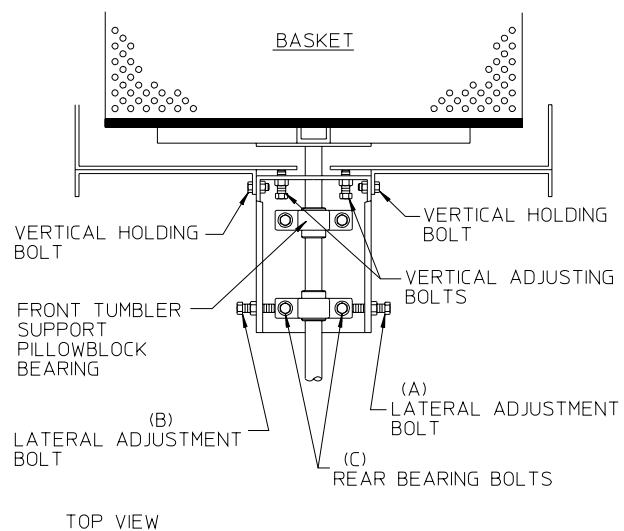

MAN0551



## Tumbler (Basket) Alignment (Lateral) (Side to Side Adjustment)

1. Discontinue electrical power to the dryer.
2. Remove back guard.
3. Loosen rear pillow block bearing bolts (C).
4. Back off jam nuts on the two (2) lateral adjustment bolts (A) and (B).
5. Simultaneously loosen one bolt and tighten the other. This will move the rear pillow block bearing. Center the tumbler (basket) in the wrapper cavity.

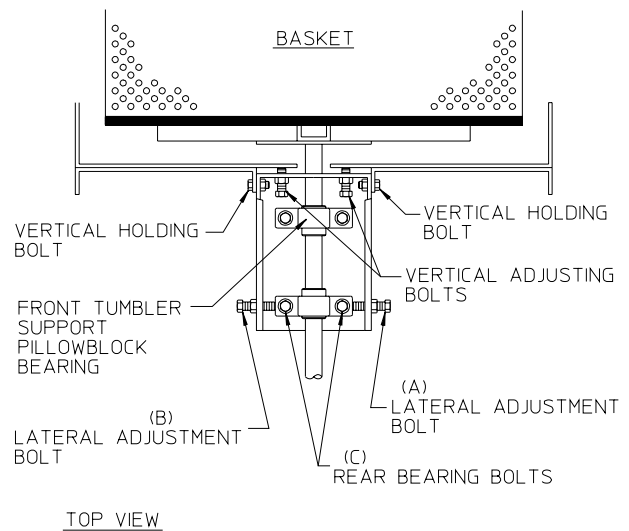

MAN0551

6. Tighten and secure both lateral adjustment bolts (A) and (B) and jam nuts.
7. Tighten pillow block bearings bolts (C) loosened in **Step #3**.
8. Replace back guard.
9. Reestablish electrical power to the dryer.

## To Replace Tumbler (Basket) or Tumbler (Basket) Support

1. Discontinue electrical power to the dryer.
2. Follow procedure for removal of main door assembly.
3. Follow procedure for removal of front panel assembly.
4. Remove back guard.
5. Remove tumbler (basket) belts.
6. Remove tumbler (basket) pulley.
7. Remove tumbler (basket) assembly and support.
  - a. Loosen the two (2) set screws on both the pillow block bearing collars.
  - b. Remove the retaining rings from the grooves of the tumbler (basket) shaft.
  - c. Remove the tumbler (basket) and support assembly from the front of the dryer. If the tumbler (basket) **cannot** be removed freely, clean the shaft area and spray WD-40 or similar lubricant. With a block of wood against the shaft end, strike the block of wood with a hammer or mallet to move the shaft past any burrs made by the set screws.

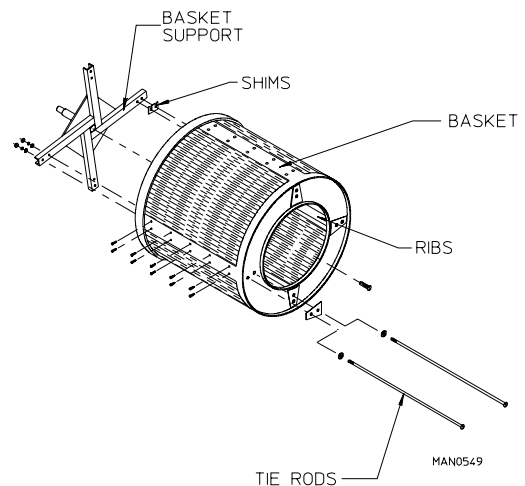

**IMPORTANT:** Never strike the shaft directly with a hammer.

8. Remove tumbler (basket) from tumbler (basket) support.
  - a. Remove the bolt in the center of the tumbler (basket) back wall.
  - b. Loosen and remove the eight (8) sets of nuts and washers from tumbler (basket) tie rods. Remove the eight (8) tie rods.
  - c. Replace either tumbler (basket) or tumbler (basket) support by reversing procedure.

**NOTE:** Shims might be needed between tumbler (basket) and tumbler (basket) support to insure proper balancing of tumbler (basket).

9. Reassemble components onto dryer by reversing *Step #2 through Step #8*.
10. Check tumbler (basket) vertical/lateral alignment and adjust if necessary.
11. Replace back guard.
12. Reestablish electrical power to the dryer.

## H. BEARINGS (Refer to illustrations in section F “Pulleys” on page 26)

### To Replace Rear Tumbler (Basket) Support Pillow Block Bearing

1. Discontinue electrical power to the dryer.
2. Remove back guard.
3. Remove tumbler (basket) pulley.
4. Loosen lateral adjustment jam nuts and bolts. (Refer to illustration in section G “Tumbler (Basket) Alignment”)
5. Loosen two (2) set screws from rear pillow block bearing collar.
6. Remove the rear bearing bolts, securing bearing to bearing mount. Remove bearing.
7. Replace by reversing *Step #3 through Step #6*.
8. Adjust both lateral and vertical tumbler (basket) alignment.
9. Replace back guard.
10. Reestablish electrical power to the dryer.

### To Replace Front Tumbler (Basket) Support Pillow Block Bearing

1. Discontinue electrical power to the dryer.
2. Remove back guard.
3. Follow *Step #3 through Step #6* from “To Replace Rear Tumbler (Basket) Support Pillow Block Bearing.”

4. Remove the two (2) retaining rings from the tumbler (basket) shaft.
5. Remove the two (2) bolts holding the front tumbler (basket) support pillow block bearing to the dryer.
6. Loosen bearing collar set screws (2) and as the end of the tumbler (basket) shaft is lifted up slightly, slide the bearing off the shaft.
7. Prop a block of wood between the tumbler (basket) shaft and the bearing mount to keep the tumbler (basket) level and in place.
8. Replace by reversing *Step #2 through Step #6*.

**NOTE:** Before replacing back guard, check tumbler (basket) lateral/vertical adjustment, as well as, belt adjustment and readjust if necessary.

9. Reestablish electrical power to the dryer.

### To Replace Front Idler Shaft Pillow Block Bearing

(Bearing nearest the back of the dryer)

1. Discontinue electrical power to the dryer.
2. Remove V-belts from idler pulleys.
3. Remove bolts holding each idler pillow block bearing to mount.
4. Remove idler shaft (with both bearings and idler pulleys still attached) from dryer.
5. Remove end retaining ring and loosen the two (2) set screws in the bearing race collar.
6. Slide bearing off the shaft.
7. Replace bearing by reversing procedure.
8. Align idler pulley with tumbler (basket) pulley before tightening bolts.
9. Reestablish electrical power to the dryer.

### To Replace Rear Idler Shaft Pillow Block Bearing

1. Follow *Step #1 through Step #3* from “To Replace Front Idler Shaft Pillow Block Bearing.”
2. Remove retaining rings on each side of forward idler shaft pillow block bearing.
3. Loosen the two (2) set screws on each bearing collar.
4. Slide both bearings off the shaft.
5. Replace by reversing procedure.
6. Reestablish electrical power to the dryer.

## I. V-BELTS

V-belts should have proper tension. If too loose, they will slip, if too tight, excessive wear on the bearings will result. If the pulleys are not properly aligned, excessive belt wear will result. Proper belt tension will allow 1/2" displacement under normal thumb pressure at mid span of belt.

**NOTE:** Belts *must always be* replaced in pairs (matched sets).

### V-Belt Tension Adjustment (Tumbler [Basket] to Idler)

1. Discontinue electrical power to the dryer.
2. Back off jam nuts on idler adjustment belts.
3. Tighten belts by turning both bolts evenly clockwise (CW). (Turn counterclockwise [CCW] to loosen belts.)
4. Check vertical plane of idler pulley for parallel alignment with tumbler (basket) pulley.
5. If realignment is required, loosen tumbler (basket) pulley and bushing, and move tumbler (basket) pulley to proper position.
6. Retighten jam nuts.
7. Reestablish electrical power to the dryer.

### V-Belt Tension Adjustment (Motor to Idler)

1. Discontinue electrical power to the dryer.
2. Loosen the nuts on the four (4) studs holding the drive motor mount to the back of the dryer.
3. Loosen the jam nuts on the adjustment screw out the top of the motor mount.
4. Turn the adjustment screw to lower the motor mount (to tighten the belts) or raise the motor mount (to loosen the belts).
5. Check the vertical plane of the motor pulley and idler pulley for parallel alignment.
6. If realignment is required, loosen motor pulley and bushing and move motor pulley to proper position.
7. Retighten motor mount bolts and jam nuts.
8. Reestablish electrical power to the dryer.

### To Replace V-Belts

1. Loosen tension on V-belts so that they can easily be rolled off pulleys.
2. Replace V-belts.
3. Retighten V-belts and adjust tension and alignment per previous instructions.

**NOTE:** Always replace belts in matched sets (2 belts).

## J. MOTORS

### To Replace Drive Motor

1. Discontinue electrical power to the dryer.
2. Remove drive belts.
3. Disconnect wiring harness from motor.
4. Remove bolts holding motor to mount and replace with new motor. **DO NOT** tighten bolts.
5. Remove pulley from old motor and install on new motor.
6. Align motor pulley with idler pulley and align motor shaft with idler shaft and tighten bolts.
7. Replace belts and adjust belt tension.
8. Retighten bolts.
9. Reestablish electrical power to the dryer.

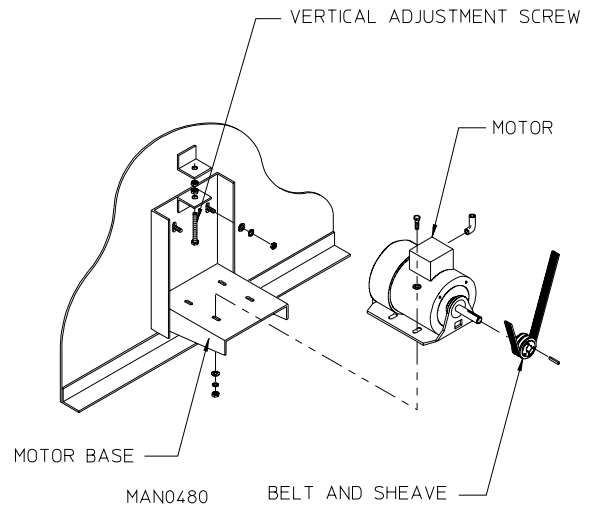

### To Replace Impellor Motor (Fan Shaft Drive)

1. Discontinue electrical power to the dryer.
2. Remove drive belts.
3. Disconnect wiring harness from motor.
4. Remove bolts holding motor to mount and replace with new motor. **DO NOT** tighten bolts.
5. Remove pulley from old motor and install on new motor.
6. Align motor pulley with fan shaft pulley and tighten bolts.
7. Replace belts and adjust belt tension.
8. Retighten bolts.
9. Reestablish electrical power to the dryer.

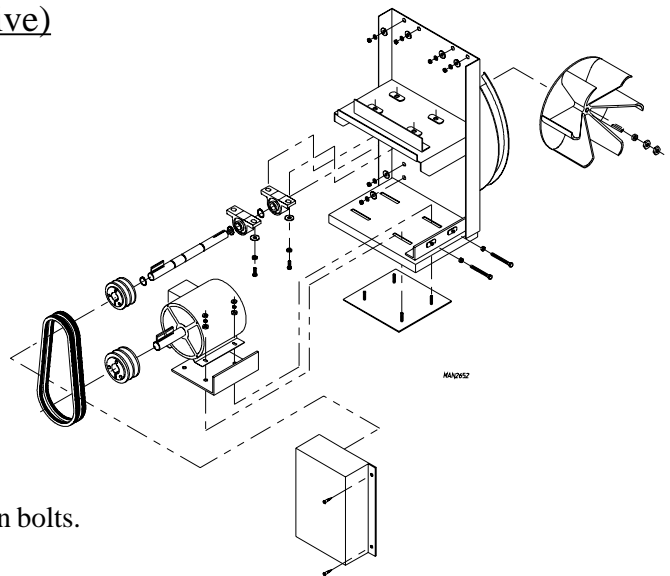

## K. IMPELLOR

1. Discontinue electrical power to the dryer.
2. Remove the left side panel to access the fan shaft mount assembly.
3. Remove the two (2) left handed jam nuts that hold the impellor to the fan shaft.
4. Remove the impellor, washers, and the key.
5. Replace the impellor, key, washers, left handed jam nuts, and the side panel.
6. Reestablish electrical power to the dryer.

## L. LINT DRAWER ASSEMBLY

### To Replace Lint Screen

1. Pull out lint drawer.
2. Remove lint screen from lint drawer.
3. Drop new lint screen in place.
4. Slide lint drawer back into dryer.

### To Replace Lint Drawer Switch

1. Disconnect electrical power to the dryer.
2. Remove lint drawer and lint door.
3. Disconnect both 4-pin connectors at the rear of the lint switch cover.
4. Remove the two (2) hex nuts securing the lint switch guard weldment to the lint drawer track.
5. Remove screw from the lint switch cover and disconnect the two (2) terminals of the switch.
6. Remove switch by pressing tabs together and push switch out.
7. Install new switch by reversing procedure.

# SECTION VI

## TROUBLESHOOTING

**IMPORTANT:** YOU MUST DISCONNECT and LOCKOUT THE ELECTRIC SUPPLY and THE GAS SUPPLY or THE STEAM SUPPLY BEFORE ANY COVERS or GUARDS ARE REMOVED FROM THE MACHINE TO ALLOW ACCESS FOR CLEANING, ADJUSTING, INSTALLATION, or TESTING OF ANY EQUIPMENT per OSHA (Occupational Safety and Health Administration) STANDARDS.

The information provided will help isolate the most probable component(s) associated with the difficulty described. The experienced technician realizes, however, that a loose connection or broken/shorted wire may be at fault where electrical components are concerned...and not necessarily the suspected component itself.

**IMPORTANT:** When replacing blown fuses, the replacement *must be* of the exact rating as the fuse being replaced. The information provided *should not be* misconstrued as a handbook for use by an untrained person in making repairs.

**WARNING:** ALL SERVICE and TROUBLESHOOTING *SHOULD BE PERFORMED BY A QUALIFIED PROFESSIONAL* or SERVICE AGENCY.

**WARNING:** WHILE MAKING REPAIRS, OBSERVE ALL SAFETY PRECAUTIONS DISPLAYED ON THE DRYER or SPECIFIED IN THIS MANUAL.

### A. No display on computer...

1. Open circuit breaker switch or blown fuse.
2. Tripped blower motor overload.
3. Faulty wiring connection.
4. Faulty transformer.
5. "EMERGENCY STOP" (E-Stop) button is depressed.
6. Faulty microprocessor controller (computer).

### B. Computer will not accept keyboard (touchpad) entries...

1. Keyboard (touchpad) ribbon is not plugged into computer securely.
2. Faulty keyboard (touchpad).
3. Faulty microprocessor controller (computer).

**C. Dryer will not start, but computer display indicators are on...**

1. Failed contactors.
2. Failed arc suppressor (A.S.) board.
3. Failed microprocessor controller (computer).
4. Failed motors.

**D. Drive motor runs, burner is on, but tumbler (basket) will not turn...**

1. Broken, damaged, or loose V-belt.
2. Belts contaminated (oil, grease, etc.).
3. Loose or broken pulley.

**E. Dryer operates but is taking too long to dry...**

1. Improperly programmed microprocessor controller (computer).
2. An inadequate exhaust duct work system.
3. Restriction in exhaust system.
4. Insufficient make-up air.
5. Poor housekeeping.
  - a. Dirty or clogged lint screen.
6. Washing machine extractors are not performing properly.
7. An exceptionally cold/humid or low barometric pressure atmosphere.
8. The supply gas may have a low heating valve, check with local gas supplier.
9. Failed temperature sensor (temperature calibration is incorrect).
10. Failed microprocessor controller (computer).



#### **F. Thermal overload for drive motor is tripping...**

1. Either an exceptionally low or high voltage supply.
2. Motor bearing failure.
3. Motor vents are blocked with lint.
4. Failed motor.
5. Failed overload.
6. Out of balance impellor (fan).
7. Insufficient make-up air.

#### **G. Overload for impellor (fan) motor is tripping...**

1. Either an exceptionally low or high voltage supply.
2. Motor bearing failure.
3. Motor vents are blocked with lint.
4. Failed motor.
5. Failed overload.
6. Insufficient make-up air.

#### **H. Burner hi-limit safety thermostat is tripping...**

1. Insufficient exhaust duct work, size, or restriction in exhaust system.
2. Insufficient make-up air.
3. Lint screen needs cleaning.
4. Damaged impellor.

**NOTE:** For models with the manual reset hi-limit thermostat refer to **page 23**.

**I. Display reads “Temp Sensor Failure Check Temp Sensor Fuse.” Dryer Sensor Circuit Failure...**

1. Check 1/8-amp fuse on microprocessor controller (computer).
2. Faulty microprocessor controller (computer) temperature sensor probe.
3. Open circuit in either one (1) of two (2) wires leading from the sensor probe to the computer..
  - a. Connection at sensor bracket assembly connector.
  - b. Connection at computer harness connector.
4. Faulty microprocessor controller (computer).

**J. Dryer does not start. Display reads “main door” or “lint door” with an audio indication...**

1. Main door is open.
2. Lint drawer is open.
3. Faulty main door or lint door switch.
4. Open circuit in either main door or lint drawer switch harnesses.
5. Faulty 24 VAC transformer.

**K. There is excessive vibration coming from the tumbler (basket)...**

1. Tumbler (basket) is out of adjustment.
2. Drive shaft or idler shaft is out of alignment.
3. Faulty pillow block bearing.
4. Faulty tumbler (basket) wheel.
5. Drive motor and shaft not aligned.

# SECTION VII

## PHASE 6 OPL SYSTEM DIAGNOSTICS

**IMPORTANT: YOU MUST DISCONNECT and LOCKOUT THE ELECTRIC SUPPLY and THE GAS SUPPLY or THE STEAM SUPPLY BEFORE ANY COVERS or GUARDS ARE REMOVED FROM THE MACHINE TO ALLOW ACCESS FOR CLEANING, ADJUSTING, INSTALLATION, or TESTING OF ANY EQUIPMENT per OSHA (Occupational Safety and Health Administration) STANDARDS.**

ALL major circuits, including door, microprocessor temperature sensor, heat and motor circuits are monitored. The Phase 6 OPL microprocessor controller (computer) will inform the user, via the L.E.D. (light emitting diode) display of certain failure codes, along with indicators both in L.E.D. display and at the output of each relay (and door switch circuit) to easily identify failures.

### A. DIAGNOSTIC (L.E.D. [light emitting diode] DISPLAY) FAILURE CODES

1. **SAIL SWITCH FAIL**- This routine will prevent start up on the machine unless the sail switch is in the correct position. If the sail switch is closed prior to start up the display will read "SAIL SWITCH FAIL" along with an audio indication.
2. **No AIRFLOW**- If the sail switch opens during cycle operation the display will read "No AIRFLOW" along with an audio indication. The machine will continue to run with no heat for three (3) minutes or until the temperature drops below 100° F (38° C). Upon failure the machine will shut down and display "No AIRFLOW" with an audio indication.
3. **bURNER SAFETY FAIL**- Routine monitors the temperature above the burner. If the burner hi-limit switch opens the display will read "bURNER SAFETY FAIL." The machine will run with no heat for three (3) minutes or until the temperature drops below 100° F (38° C). Upon failure the machine will shut down and display "bURNER SAFETY FAIL" with an audio indication.
4. **dRUM SAFETY FAIL**- This routine monitors the tumbler (basket) temperature if the tumbler (basket) hi-limit switch opens prior or during the cycle while the heat was on the machine will display "dRUM SAFETY FAIL." The machine will continue to run with no heat for three (3) minutes or until the temperature drops below 100° F (38° C). Upon failure the machine will shut down and display "dRUM SAFETY FAIL" with an audio indication.
5. **No HEAT**- This routine monitors the burner ignition. If the burner mis-ignites (does not light) the HSI (Hot Surface Ignition) module will check to see of the microprocessor program has any retries left. The standard retry count is two (2). If the module notices that there are retries left it will purge for one (1) minute then try to ignite the burner again. The HSI module will try this for a total of three (3) times or until there are no retries left. If the burner does not ignite after three (3) attempts the L.E.D. (light emitting diode) display will display the error code "no heat" with an audio indication. When this occurs the machine will run with no heat for three (3) minutes or until the temperature drops below 100° F (38° C).

**IMPORTANT:** For other countries, such as Australia, the retry count may not apply due to local approvals.

6. **bURNER CONTROL FAIL-** This routine monitors the ignition control's gas valve output response. If the valve output signal is not present from the ignition control within the valve time limits the Phase 6 microprocessor controller (computer) determines the ignition control has failed. If this occurs when the cycle is active the machine will display "bURNER CONTROL FAIL." If the tumbler (basket) temperature is above 100° F (38° C) the machine will continue to display "bURNER CONTROL FAIL." The machine will run with no heat for three (3) minutes or until the temperature drops below 100° F (38° C). If the tumbler (basket) temperature is below 100° F (38° C) upon failure the machine will shut down and display "bURNER CONTROL FAIL" with an audio indication.
7. **bURNER FLAME FAIL-** This routine allows two (2) flame out retries to occur before proceeding into the error. The count of two (2) will be established every time the call for heat was to occur. Only if it reaches the count of two (2) before the tumbler (basket) temperature has reached the set temperature will this error be triggered. The machine will run with no heat for three (3) minutes or until the temperature drops below 100° F (38° C). If the tumbler (basket) temperature is below 100° F (38° C) upon failure, the machine will shut down and display "bURNER FLAME FAIL" with an audio indication. This process will occur every time the heat output is active.
8. **MAIN DOOR-** This monitors the door circuit. If the machine was not active and the main door was opened the display would read "REAdY." If a program attempt was made with the main doors open the display will read "MAIN dOOR" with an audio indication. If the machine is active and the main door was opened the display would read "MAIN dOOR" with no audio indication and the dryer will shut down. Once the main door has closed the display would read "PRESS START" press the "ENTER/START" key and it will continue the programmed cycle.
9. **LINT dOOR-** This monitors the lint drawer and door circuit. If the machine was not active and the lint drawer and door was opened the display would read "REAdY." If a program attempt was made with the lint drawer and door open the display would read "LINT dOOR" with an audio indication. If the machine is active and the lint drawer and door was opened the display would read "LINT dOOR" with no audio indication and the dryer will shut down. Once the lint door was closed the display would read "PRESS START" press the "ENTER/START" key and it will continue the programmed cycle.
10. **TEMP SENSOR FAIL CHECK TEMP SENSOR FUSE-** This routine monitors the tumbler (basket) temperature. When the temperature sensor or fuse opens with the machine not active the display will read "TEMP SENSOR FAIL CHECK TEMP SENSOR FUSE" with an audio indication. If the machine was active at the time that the temperature sensor or fuse opened the display would read "TEMP SENSOR FAIL CHECK TEMP SENSOR FUSE." If the tumbler (basket) temperature is above 100° F (38° C) the machine will continue to display "TEMP SENSOR FAIL CHECK TEMP SENSOR FUSE" with an audio indication and run with no heat for three (3) minutes or until the temperature drops below 100° F (38° C). If the tumbler (basket) temperature is below 100° F (38° C) upon failure the machine will shut down and display "TEMP SENSOR FAIL CHECK TEMP SENSOR FUSE" with an audio indication. The display will continue to read "TEMP SENSOR FAIL CHECK TEMP SENSOR FUSE" an audio indication will sound for approximately 5 seconds, every 30 seconds until the problem is corrected or the power to the dryer is disconnected (and the problem is corrected).

**NOTE:** Once the Phase 6 microprocessor controller (computer) detects a problem in the heat circuit, it updates every 30 seconds, so that if the problem was a loose connection in the circuit which corrected itself, the "TEMP SENSOR FAIL CHECK TEMP SENSOR FUSE" condition would automatically be cancelled and the display will return to "REAdY."

11. **ROTATE SENSOR FAIL-** Indicates a rotational sensor circuit failure meaning that there is a fault somewhere in the tumbler (basket) rotating circuit, or the Phase 6 OPL microprocessor controller (computer) program related to this circuit (program location 2) is set incorrectly. In the active mode it **should be** (ROTATE SENSOR ACTIVE), if the dryer is not equipped with the optional rotational sensor it **should be** set in the nonactive mode (No ROTATE SENSOR).

**NOTE: RPM-** This routine monitors the timing response from the existing rotational sensor input and derives a RPM measurement. To display this RPM measurement (press the “ENTER/START” key once and release, then press the “ENTER/START” key a second time and hold. This will display the RPM measurement). The rotational sensor *must be* active for operation of this feature.

12. **CHECK MAIN FUSE-** Indicates that the circuit fuse protection which is located on the back side of the Phase 6 microprocessor controller (computer) the display would read “CHECK MAIN FUSE.” If the display continues after the fuse has been replaced then it is the fault of the Phase 6 microprocessor controller (computer).

## B. L.E.D. (light emitting diode) DISPLAY INDICATORS

The L.E.D. (light emitting diode) indicator dots located on the top portion of the display indicates various Phase 6 OPL computer output functions while a cycle is in progress. These indicator dots (as shown in the illustration below) **DO NOT** necessarily mean that the outputs are functioning. They are only indicating that the function output **should be** active (on).

### 1. L.E.D. DISPLAY INDICATOR NUMBER 1

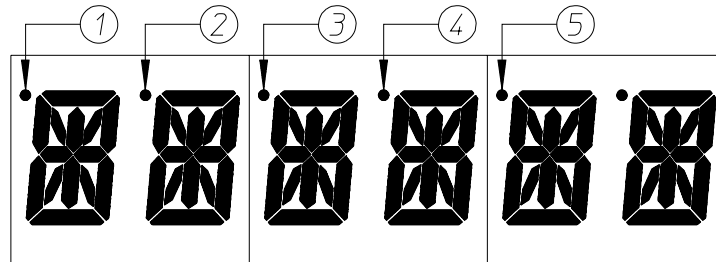

MAN3450

- a. For Optional Reversing Models:

- 1) This indicator dot is on when the drive (tumbler [basket]) motor is operating in the forward mode (clockwise [CW] direction).

### 2. L.E.D. DISPLAY INDICATOR NUMBER 2

- a. For Optional Reversing Models:

- 1) This indicator dot is on when the drive (tumbler [basket]) motor is operating in the reverse mode (counterclockwise [CCW] direction).

### 3. L.E.D. DISPLAY INDICATOR NUMBER 3

- a. Heat Circuit Indicator:

- 1) This indicator dot is on whenever the Phase 6 OPL microprocessor controller (computer) is calling for the heating circuit to be active (on).

#### 4. L.E.D. DISPLAY INDICATOR NUMBER 4

a. On Indicator:

- 1) This indicator dot is on whenever a cycle is in progress. Additionally, when the Anti-Wrinkle program is active, the indicator dot will be on whenever the Phase 6 OPL microprocessor controller (computer) is in the Guard On Time program.

#### 5. L.E.D. DISPLAY INDICATOR NUMBER 5

a. Air Jet Circuit - **OPTIONAL**

- 1) This indicator dot is on at the end of the dryer cycle for approximately 60 seconds.

### C. PHASE 6 OPL MICROPROCESSOR CONTROLLER (COMPUTER) RELAY OUTPUT L.E.D. (light emitting diode) INDICATORS

There are a series of five (5) L.E.D. indicators (ORANGE LIGHTS) located at the backside of the Phase 6 OPL microprocessor controller (computer). These are identified or labeled (from top to bottom in the illustration below as: FAN-BLOWER, FOR-FORWARD, REV-REVERSE, AIR-AIR-JET, HT1-HEAT OUTPUT). There are a series of seven (7) L.E.D. indicators (red lights) FUSE-MAIN FUSE, LINT-LINT DOOR, MAIN-MAIN DOOR, DRUM-TUMBLER HI-LIMIT, SAIL-SAIL SWITCH, BURN-BURNER HI LIMIT, FLAME-FLAME PROBE). The L.E.D. in the center of the board (red light) indicates power supplied to the Phase 6 OPL microprocessor controller (computer). These L.E.D.'s indicate the inputs and outputs of the Phase 6 OPL microprocessor (computer) as it monitors the safety circuits.

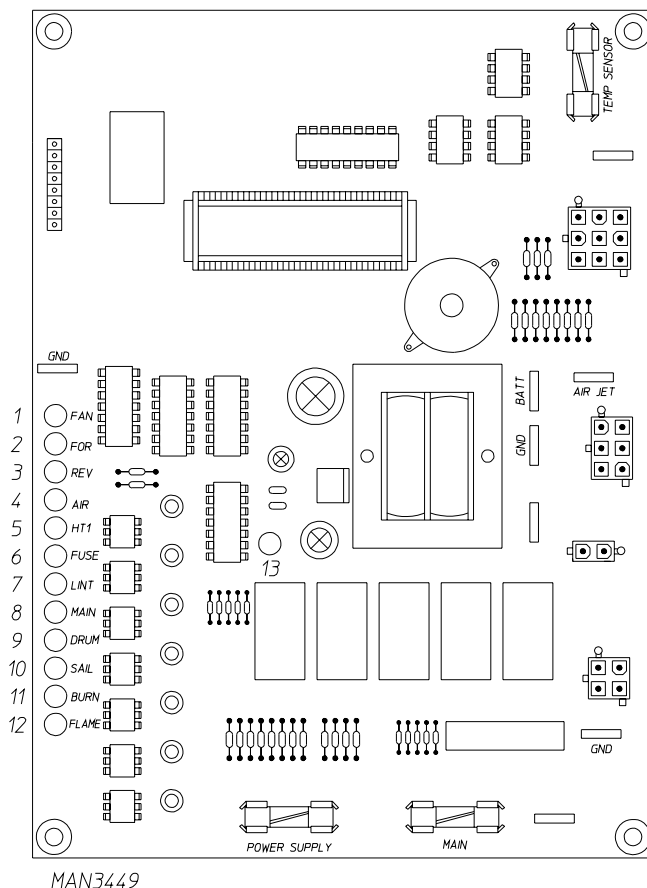

## 1. “FAN” (BLOWER) Output L.E.D. Indicator

- a. If the dryer is started and the blower motor is is not operating, yet the Phase 6 OPL microprocessor controller (computer) display fan indicator dot and power supply input L.E.D. are on, but the fan output L.E.D. is off, then the fault is the Phase 6 OPL microprocessor controller (computer) itself.
  - 1) If the motor is not operating. The fan indicator dot and output L.E.D. are also on, then the problem (fault) is elsewhere (i.e., external of the Phase 6 OPL microprocessor controller [computer]).

## 2. “FOR” (FORWARD) Output L.E.D. Indicator (for Optional Reversing Model ONLY)

- a. If the dryer is started and the blower motor is operating, but the drive (tumbler/basket) motor is not, yet the Phase 6 OPL microprocessor controller (computer) display “FORWARD” indicator dot is on, the “FOR” (FORWARD) motor output L.E.D. is off; then the fault is the Phase 6 OPL microprocessor controller (computer) itself.
  - 1) If the drive (tumbler and basket) motor is not operating and the forward indicator dot and output L.E.D. is on; then the problem (fault) is elsewhere (i.e., external of the Phase 6 OPL microprocessor controller [computer]).

## 3. “REV” (REVERSE) Output L.E.D. Indicator (for Optional Reversing Models ONLY)

- a. If the dryer is started and the blower motor is operating but the drive (tumbler and basket) motor is not, yet the Phase 6 OPL microprocessor controller (computer) displays “REVERSE” indicator dot is on but the “REV” (REVERSE) motor output L.E.D. is off; then the fault is of the Phase 6 OPL microprocessor controller (computer) itself.
  - 1) If the drive (tumbler and basket) motor is not operating and reverse indicator dot and output L.E.D. is on; then the problem (fault) is elsewhere (i.e., external of the Phase 6 OPL microprocessor controller [computer]).

## 4. “AIR” (AIR JET) Output L.E.D. Indicator - *OPTIONAL*

- a. “AIR” is on with the display dot at the end of the dry cycle once the display reads “dONE,” it is on for approximately 60 seconds and the output L.E.D. indicator and the display dot go out. If the air jet does not energize it is not the fault of the Phase 6 OPL microprocessor controller (computer). If the output L.E.D. or dot **DO NOT** go on it is the fault of the Phase 6 OPL microprocessor controller (computer).

## 5. “HT1” (HEAT) Output L.E.D. Indicator

- a. If the dryer is started and there is “No Heat” yet the Phase 6 OPL microprocessor controller (computer) display heat circuit indicator dot is on, but the “HT1” output L.E.D. indicator is off; then the fault is in the Phase 6 OPL microprocessor controller (computer) itself.
  - 1) If the dryer is started and there is “No Heat” yet both the Phase 6 OPL microprocessor controller (computer) display indicator dots and the “HT1” output L.E.D. indicator are on; then the problem (fault) is elsewhere (i.e., external of the Phase 6 OPL microprocessor controller [computer]).

## 6. “FUSE” (MAIN FUSE) Input L.E.D. Indicator

- a. **Should be on ALL** the time (even if the dryer is not running). If the L.E.D. is not on; then the display will read “CHECK MAIN FUSE.” If the main fuse is good then the fault is on the Phase 6 microprocessor controller (computer).

## 7. “LINT” (LINT DOOR) Input L.E.D. Indicator

- a. **Should be on ALL** the time (unless the lint door is opened then the “LINT” L.E.D. indicator will go out).
- b. If the dryer is active (running) and the lint door is opened the “LINT” L.E.D. indicator will go out and the display will read “LINT dOOR.” The dryer will stop until the Lint Drawer has been closed, at which time the L.E.D. display will read “PRESS START.” At this time, to resume the drying cycle press “ENTER/START” key.

## 8. “MAIN” (MAIN DOOR) Input L.E.D. Indicator

- a. **Should be on ALL** the time (unless the lint door is open or the main door is opened then the “MAIN” L.E.D. indicator will go out).
- b. If the dryer is active (running) and the main door is opened the “MAIN” L.E.D. indicator will go out and the display will read “MAIN dOOR.” The dryer will stop until the main door has been closed, at which time the L.E.D. display will read “PRESS START.” At this time, to resume the drying cycle press “ENTER/START” key.

## 9. “DRUM” (TUMBLER [BASKET] HI-LIMIT) Input L.E.D. Indicator

- a. **Should be on at ALL** times (unless the tumbler [basket] hi-limit switch opens prior during the cycle while the heat was on the display would read “dRUM SAFETY FAIL”). The machine will run with no heat for three (3) minutes or until the temperature drops below 100° F (38° C). Then the machine will shut down still displaying “dRUM SAFETY FAIL” with an audio indication.

## 10. “SAIL” (SAIL SWITCH) Input L.E.D. Indicator

- a. This routine will prevent start up on the machine unless the sail switch is in the correct position. If the sail switch is in the closed position prior to start, the “SAIL” output L.E.D. indicator will be off, the machine will not start and the display will read “SAIL SWITCH FAIL” along with an audio indication.
- b. If the sail switch opens during the cycle the “SAIL” output L.E.D. will go out and the display will read “NO AIRFLOW.” The machine will run with no heat for three (3) minutes or until the temperature drops below 100° F (38° C). Then the machine will shut down still displaying “NO AIRFLOW” along with an audio indication.

## 11. “BURN” (BURN HI-LIMIT) Input L.E.D. Indicator

- a. This routine monitors the temperature of the burner. If the burner hi-limit opens during the cycle while the heat was on the “BURN” output L.E.D. indicator goes out and the display reads “bURNER SAFETY FAIL.” The machine will run with no heat for three (3) minutes or until the temperature drops below 100° F (38° C) then the machine will shut down still displaying “bURNER SAFETY FAIL” with an audio indication.



## 12. “FLAME” (bURNER CONTROL FAIL) Input L.E.D. Indicator

- a. This routine monitors the ignition control’s gas valve output response. If the valve output signal is not present from the ignition control within the valve time limits the microprocessor determines the ignition control has failed. If this occurs when the cycle is active the “FLAME” output L.E.D. indicator will go out and the display will read “bURNER CONTROL FAIL.” The machine will run with no heat for three (3) minutes or until the temp drops below 100° F (38° C). Then the machine will shut down still displaying “bURNER CONTROL FAIL” with an audio indication.

## 13. “POWER SUPPLY” Input L.E.D. Indicator

- a. **Should be** on at **ALL** times (even if the dryer is not running). The power supply L.E.D. (light emitting diode) output indicator will not be on if the power supply fuse to the Phase 6 OPL microprocessor is not present. If the power supply fuse is faulty the L.E.D. output will be off and there will be no display or keyboard (touchpad) function. The “FUSE,” “LINT,” and “DRUM” output L.E.D. indicators will remain on.

## D. L.E.D. CODES

### 1. Display Codes

A	SLOPE FACTOR
ALL REV	ALWAYS REVERSING
ANTI WRINKL dELAY TIME	ANTI-WRINKLE DELAY TIME
ANTI WRINKL GUARd ACTIVE	ANTI-WRINKLE PROGRAM ACTIVE
ANTI WRINKL GUARd ON TIME	ANTI-WRINKLE GUARD ON TIME
AUTO CYCLE	AUTOMATIC MODE
b	HEAT LOSS (OFF SET) FACTOR
bURNER CONTROL FAIL	GAS ONLY POWER (24 VAC) <u>IS NOT</u> EVIDENT AT GAS VALVE
bURNER FLAME FAIL	NO BURNER FLAME SENSED
bURNER SAFETY FAIL	GAS/ELECTRIC ONLY BURNER/OVEN OPEN HI-LIMIT CIRCUIT
bUZZ	BUZZER (TONE)
bUZZ TIME	BUZ TIME
CEL	DEGREE IN CELSIUS
CHECK MAIN FUSE	MAIN FUSE FAILURE
CLEAN LINT	PROMPT TO CLEAN LINT SCREEN, DRYER CYCLE LOCKOUT
COOL	COOL DOWN CYCLE IN PROGRESS
COOL TIME_M	COOL DOWN TIME
COOL TEMP_	COOL DOWN TEMPERATURE
CYCLEa	PREPROGRAMMED CYCLE A
CYCLEb	PREPROGRAMMED CYCLE B
CYCLEc	PREPROGRAMMED CYCLE C
CYCLED	PREPROGRAMMED CYCLE D
CYCLEE	PREPROGRAMMED CYCLE E
CYCLEF	PREPROGRAMMED CYCLE F
dONE	DRYING or COOLING CYCLE COMPLETE or DRYER IN ANTI-WRINKLE MODE
dRYING	DRYING CYCLE IN PROGRESS
dRY LEVEL_	DRYNESS LEVEL (PERCENTAGE OF EXTRACTION) (NUMERICAL VALUE)
dRY TEMP F_	DRYING TEMPERATURE
dRY TIME_M	LENGTH OF DRYING CYCLE
dRUM SAFETY FAIL	TUMBLER HI-LIMIT CIRCUIT IS OPEN
ELAPSE TIME_MIN	CYCLE DISPLAY TIME
ELECTRIC	SPECIFIC HEAT TYPE or DRYER ELECTRICALLY HEATED
F	FABRIC TEMPERATURE
FAR	DEGREE IN FAHRENHEIT
FLASH	FLASH DISPLAY ACTIVE
GAS	SPECIFIC HEAT TYPE OF DRYER GAS HEATED
HOT	INDICATES AN OVERHEAT CONDITION
LINT dOOR	LINT DRAWER/DOOR CIRCUIT IS OPEN OR FAULT IN THE A.C. SWITCH CIRCUIT
LINT COUNT	DRYING CYCLES RANGE FROM 1-10 CYCLES BEFORE CLEAN LINT DISPLAY
_M REMAIN	CYCLE DISPLAY TIME
MAIN dOOR	DOOR CIRCUIT IS OPEN or FAULT IN THE A.C. DOOR SWITCH CIRCUIT
MANUAL CYCLE	MANUAL MODE
MAX ANTI WRINKL GUARd	MAXIMUM GUARD TIME
NFLASH	FLASH DISPLAY NOT ACTIVE
NoAIRFLOW	SAIL SWITCH OPEN
NoANTI WRINKL GUARd	ANTI-WRINKLE PROGRAM <u>IS NOT</u> ACTIVE
NoBUZZ	NO BUZZER (TONE)
NoHEAT	GAS ONLY IGNITION ATTEMPT FAILURE
NoREV	NO REVERSE
No ROTATE SENSOR	NO ROTATIONAL SENSOR SELECTED
PROGRAM	PROGRAM MODE
REAdY	NO CYCLE IN PROGRESS
ROTATE SENSOR ACTIVE	ROTATIONAL SENSOR SELECTED
ROTATE SENSOR FAIL	ROTATIONAL SENSOR CIRCUIT FAILURE
_RPM	MONITORS TUMBLER RPM WITH ROTATIONAL SENSOR CIRCUIT ACTIVE
SAIL SWITCH FAIL	GAS/ELECTRIC ONLY ATTEMPT MADE TO START DRYER WITH SAIL SWITCH DISABLED IN CLOSED POSITION
SELREV	SELECT REVERSE
SPIN TIME	SPIN TIME
START GUARd	START ANTI-WRINKLE GUARD CYCLE
STEAM	SPECIFIC HEAT TYPE or DRYER STEAM HEATED
STOP TIME	STOP TIME
TEMP SENSOR FAIL CHECK	FAULT IN M.P. HEAT SENSING CIRCUIT
TEMP SENSOR FUSE	

## 2. Fault Codes

### **bURNER CONTROL FAIL**

- GAS MODELS ONLY POWER (24 VAC) IS NOT EVIDENT AT GAS VALVE

### **bURNER FLAME FAIL**

- The Phase 6 Microprocessor Controller (Computer) DOES NOT SENSE FLAME VERIFICATION (GAS MODEL ONLY)

### **bURNER SAFETY FAIL**

- GAS/ELECTRIC ONLY BURNER/OVEN OPEN HI-LIMIT CIRCUIT

### **dRUM SAFETY FAIL**

- Fault in the TUMBLER (BASKET) HI-LIMIT CIRCUIT

### **HOT**

- Indicates an OVERHEAT CONDITION

### **LINT dOOR**

- When the LINT DOOR OR DRAWER is open or there is a **fault** in the LINT DOOR/DRAWER CIRCUIT

### **MAIN dOOR**

- When the MAIN DOOR is open or there is a **fault** in the DOOR CIRCUIT

### **No AIRFLOW**

- **Fault** in the SAIL SWITCH CIRCUIT (GAS/ELECTRIC MODELS ONLY)

### **No HEAT**

- GAS ONLY IGNITION ATTEMPT FAILURE

### **ROTATE SENSOR FAIL**

- **Fault** in the ROTATION SENSOR CIRCUIT

### **SAIL SWITCH FAIL**

- **Fault** in the SAIL SWITCH CIRCUIT (GAS/ELECTRIC MODELS ONLY)

### **TEMP SENSOR CHECK TEMP SENSOR FUSE**

- **Fault** in the MICROPROCESSOR TEMPERATURE SENSOR CIRCUIT

## E. COMPUTER LOGIC and WIRING DIAGRAM

1. Operator enters desired selections.
2. Information entered is sent to the microprocessor (computer) via the keypad (touchpad).

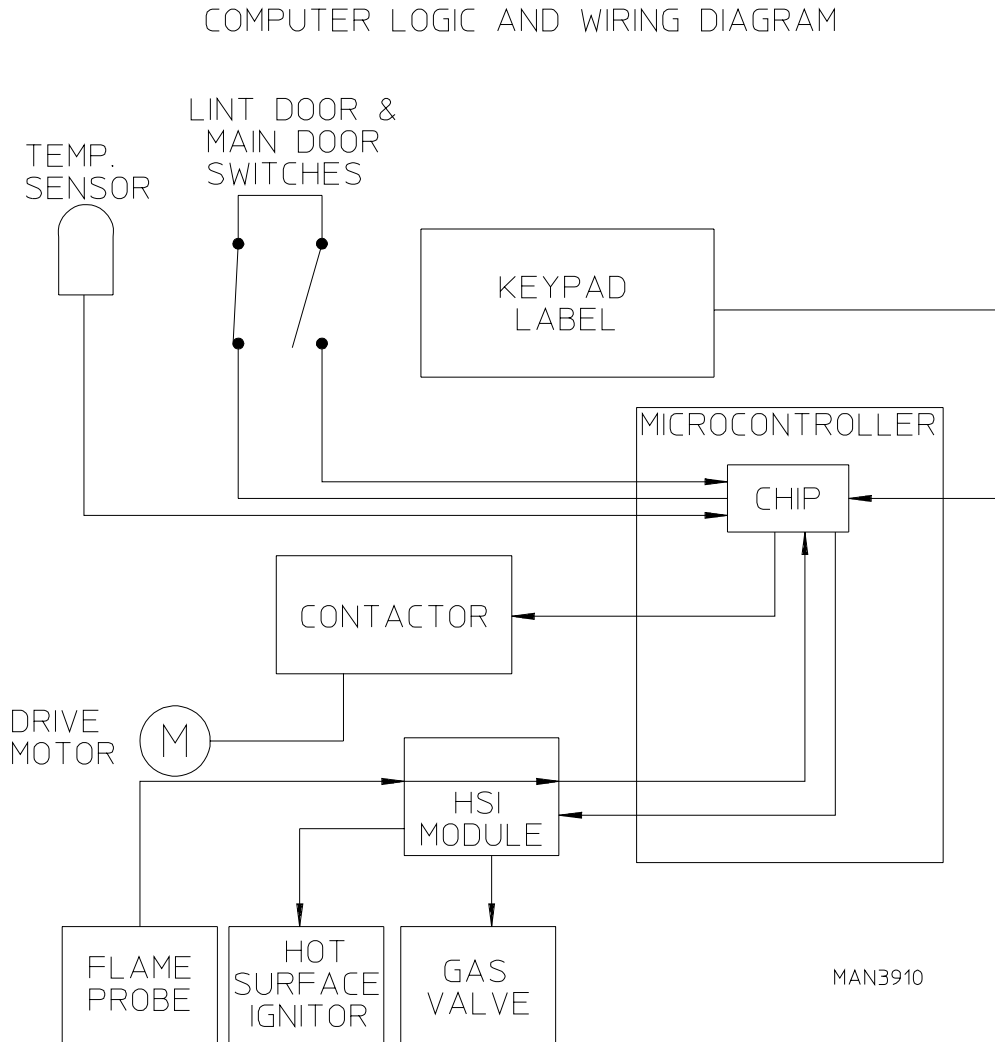

3. The input information is sorted, processed, and executed by the microcomputer chip.
4. The microcomputer output signal activates the contactors and HSI (Hot Surface Ignition) module which control machine functions.

**NOTE:** When contacting **ADC** with electrical questions, please have on hand the correct wiring diagram number for your particular machine. This number is located on the top right-hand corner of the diagram. It is a six (6) digit number followed by a letter to distinguish the revision dates (refer to illustration).

The wiring diagrams used in troubleshooting are specifically for dryers manufactured at the time of publishing. Your particular model may vary slightly depending on the date of manufacturing and options available. The correct wiring diagram and number is either taped to the rear of the control door or each dryer, or placed in the control box. If your particular diagram is lost or unreadable, call **ADC** with the serial number of the dryer. **ADC will be** more than happy to send you a diagram by fax or mail.

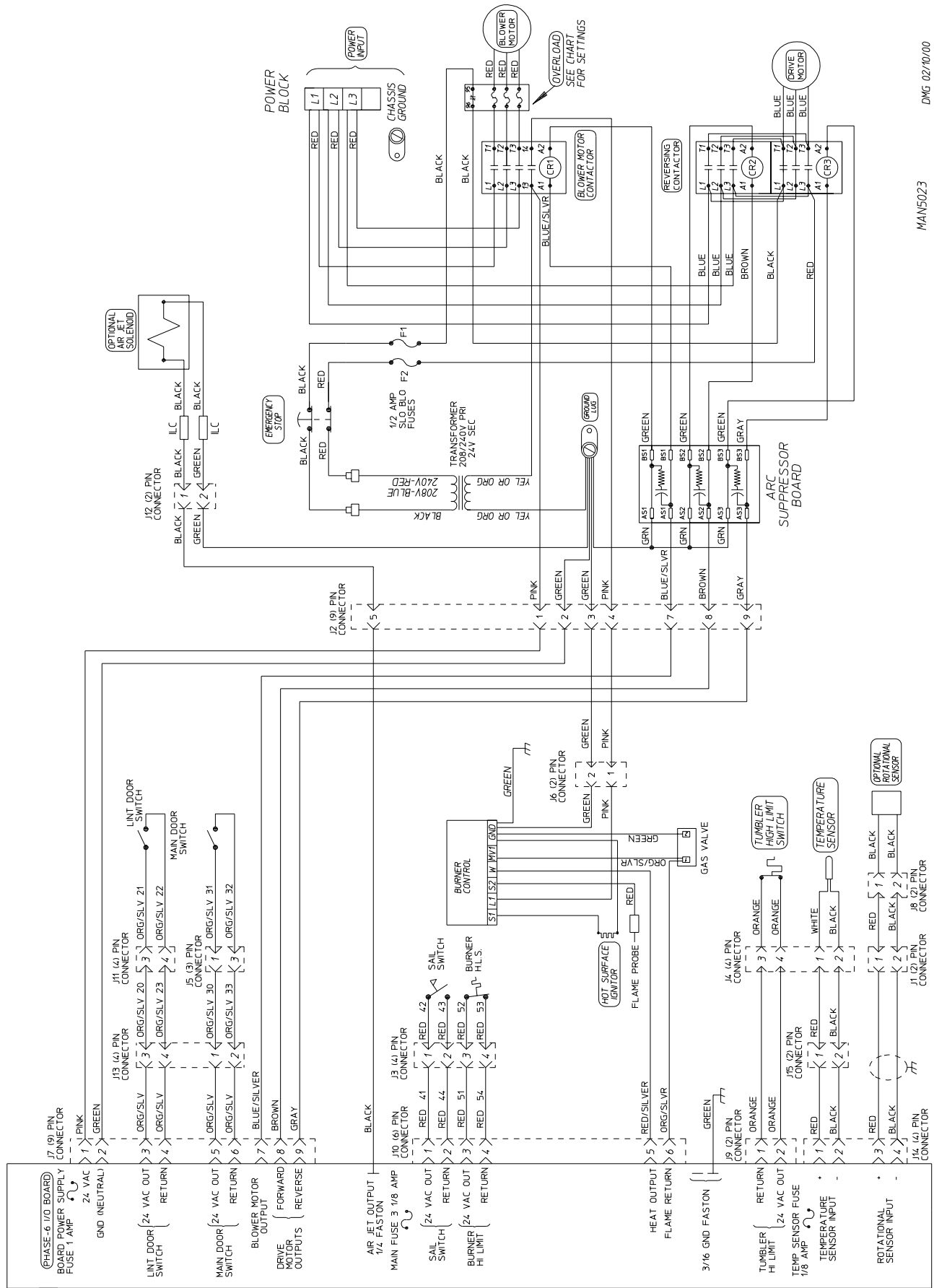

MAN5023  
 DMG 02/10/00

## 1. No Display Condition

- a. Check position of “EMERGENCY STOP” (E-Stop) to verify it is in operating position (pull or twist for operating position).
- b. Check fuse one (1) or two (2) and if either are blown, replace.
- c. Take voltage reading across the microprocessor (J7) 9-pin connector pins 1 and 2. If no voltage is present at pins 1 and 2, double check the secondary (24 VAC) side of transformer at the blower motor contactor number 13 to ground if no voltage is present check primary voltage to transformer.
- d. Check voltage across fuses 1 and 2 to ground. If voltage is present, check “EMERGENCY STOP” (E-Stop) “red” and “black” wire to ground. If voltage is present, check voltage across 95 and 96 to ground of the drive motor overload. If voltage is present, check 95 and 96 to ground of the blower motor overload. If voltage is present and transformer terminations are good, then the transformer is faulty. Refer to the schematic supplied with the dryer to assist in the troubleshooting of the dryer.

**NOTE:** In this next section ALL voltage checks *must be* done in the operating mode with the appropriate microprocessor dot on. Also appropriate L.E.D. (light emitting diode) output light on.

**NOTE:** In this next section when checking for voltage you are looking for 25 AC volts unless otherwise specified.

## 2. Drive motor reverses but does not forward, blower motor runs

- a. If computer dot (first dot on the left) does not come on replace the computer.
- b. Check for voltage across the coil of the forward contactor located in the reversing panel box. The contactor according to your diagram is marked CR2. The coil markings A1 and A2.

If voltage is present, replace reversing contactor.

If voltage is not present, there is a faulty wire or termination between BS2 and contactor coil (CR2).

- c. If there is voltage across the two (2) AS2 terminals and no voltage across the two (2) BS2 terminals, replace the arc suppressor (A.S.) board.

If there is no voltage across the two (2) AS2 terminals on the arc suppressor (A.S.) board, the problem is a faulty wire or termination between the AS2 board and the J7 9-pin computer connector no. 8 or faulty computer.

## 3. Drive motor works in forward mode but does not reverse, blower motor runs

- a. If computer dot (second one from left) does not come on, check program to see if set for reverse.
- b. If set for reverse, replace computer.
- c. Check for voltage across the coil of the reversing contactor located in the rear panel box. The contactor according to your diagram is CR3, also the markings on the coil are A1 and A2.

If there is voltage, replace the coil or the complete contactor.

If there is no voltage, check for voltage across the two (2) BS3 terminals on the arc suppressor (A.S.) board.

If there is voltage across the two (2) BS3 terminals and no voltage across the coil of the reversing contactor (A1 and A2), the problem is faulty wires or terminations between BS1 and the contactor coil.

- d. If there is no voltage between the two (2) BS3 terminals on the arc suppressor (A.S.) board, check for voltage across the two (2) AS3 terminals on the board.

If there is voltage across the two (2) AS3 terminals and no voltage across the two (2) BS3 terminals, replace the arc suppressor (A.S.) board.

If there is no voltage across the two (2) AS3 terminals, the problem is faulty wires or terminations between the arc suppressor (A.S.) board and the computer 9-pin connector no. 9 or a faulty computer.

#### 4. Blower motor does not operate, drive motor runs

- a. Check for voltage across terminals A1 and A2 of the impellor contactor. This is the single contactor in the reversing control box.

If voltage is present check for voltage across the blower motor. If there is voltage at the blower motor replace the motor.

If there is no voltage at the blower motor, the problem is faulty wires or terminations between the contactor and the motor.

- b. If there is no voltage present at A1 and A2 of the contactor, check for voltage across the two (2) BS1 terminals of the arc suppressor (A.S.) board.

If there is voltage present at the two (2) BS1 terminals, the problem is faulty wires or terminations between the two (2) BS1 terminals and the coil (A1 and A2) terminals.

If there is no voltage across the two (2) BS1 terminals, check for voltage across the two (2) AS1 terminals.

If there is voltage across the two (2) AS1 terminals and there is no voltage between the two (2) BS1 terminals, replace the arc suppressor (A.S.) board.

- c. If there is no voltage across the two (2) AS1 terminals, the problem is faulty wires or terminations between the two (2) AS1 terminals and the computer board J7 9-pin connector no. 7 or faulty computer.

#### 5. Lint Door Condition

**NOTE:** Make sure main door and lint door are closed. Also, if checking either switch, the plunger *must be* depressed.

- a. Check L.E.D. (light emitting diode) input light "LINT" on the component side of the computer. If the light is on, replace the computer.
- b. Check voltage (24 VAC) from J7 9-pin connector no. 3 to ground. If voltage is present check no. 4 to ground if voltage is present replace board.

- c. If no voltage is present at J7 9-pin connector no. 4 to ground, but voltage is present at no. 3 to ground. The problem is a faulty switch, wires or termination between J7 to J8 and J8 to the lint switch no. 20 and 21.
- d. If no voltage is present at J7 9-pin connector no. 3 to ground, then voltage **should not be** present at no. 5 to ground. Replace the board.

## 6. Main Door Condition

**NOTE:** Make sure main door and lint door are closed. Also, if checking either switch, the plunger *must be* depressed.

- a. Check L.E.D. (light emitting diode) input light “MAIN” on the component side of the computer. If the light is on, replace the computer.
- b. Check voltage (24 VAC) from J7 9-pin connector no. 5 to ground. If voltage is present, check no. 6 to ground. If voltage is present, replace board.
- c. If no voltage is present at J7 9-pin connector no. 6 to ground, but voltage is present at no. 5 to ground. The problem is a faulty switch, faulty wires or terminations J7 to J8. J8 to J5 and J5 to main door switch no. 31 and no. 32.

## 7. “No Heat” drive and blower motors run, display reads normal (gas models).

- a. Check L.E.D. (light emitting diode) input light “HT1” on the component side of the computer. If the light is on replace the board.
- b. If the L.E.D. (light emitting diode) input light “HT1” on the component side of the computer is on and there is no voltage to the HSI (Hot Surface Ignition) module “w” the display will read “BURNER CONTROL FAIL.” The problem is faulty wires or terminations between microprocessor and HSI (Hot Surface Ignition) module.
- c. If voltage is present on the HSI (Hot Surface Ignition) module “w” to ground. Check voltage at the gas valve if voltage is present across the two (2) “yellow” wires at the gas valve and the gas supply is on then the fault is that of the gas valve.

## 8. Microprocessor (Computer)

- a. Replace the temperature sensor underneath the tumbler (basket) on a bracket (the bullet shaped device).
- b. If it still reads “TEMP SENSOR FAIL CHECK TEMP SENSOR FUSE,” unplug J3 4-pin connector from the temperature sensor bracket. Also, unplug the microprocessor J14 4-pin connector from the computer board. Take a continuity reading from J14 no. 1 to J3 no. 1, then from J14 no. 2 to J3 no. 2.

If there is no continuity, check for break in wire, a short to the ground, loose terminations, or even replace the wire.

If there is continuity, computer board is faulty.





## **IMPORTANT**

### **MANUAL RESET HI-LIMIT INSTRUCTIONS**

#### **FOR PHASE 6 MODELS**

This dryer was manufactured with a manual reset burner hi-limit and tumbler (basket)/lint chamber hi-limit thermostat which is monitored by the Phase 6 computer. If either manual reset thermostat is open prior to start of the drying cycle, the dryer will start momentarily and then shut down, the Phase 6 computer will display an error code with an audio indication. If the tumbler (basket)/lint chamber hi-limit thermostat is open, the display will read “DRUM SAFETY FAIL.” If the burner hi-limit thermostat is open, the display will read “BURNER SAFETY FAIL.”

If either manual reset hi-limit thermostat opens during a drying cycle, the display will show the applicable error code described above along with an audio indication. If the drum temperature is above 100° F (38° C), the dryer will continue to run with no heat for three (3) minutes or until the drum temperature has flattened below 100° F (38° C). The clear/stop button on the Phase 6 keyboard (touchpad) **must be** pressed to clear the error condition. The open manual reset hi-limit thermostat **must be** reset “manually” prior to the start of the next cycle.

This hi-temperature condition may be caused due to a restricted exhaust, poor airflow, or improper burner operation.

The location of the burner hi-limit is on the right side of the burner box and the tumbler (basket) hi-limit is located in the lint chamber area.

**WARNING:** Discontinue power to dryer before attempting to reset hi-limit.

## **IMPORTANT**

This dryer is equipped with a burner hi-limit and tumbler/lint chamber hi-limit thermostat which **must be** reset manually.

**WARNING:** Discontinue power to dryer before attempting to reset hi-limit.

# SECTION VIII

## TECHNICAL INFORMATION

The following section contains various technical information important to the service person in servicing and maintaining the dryer.

### A. MOTOR PLATE (HIGH and LOW VOLTAGE)

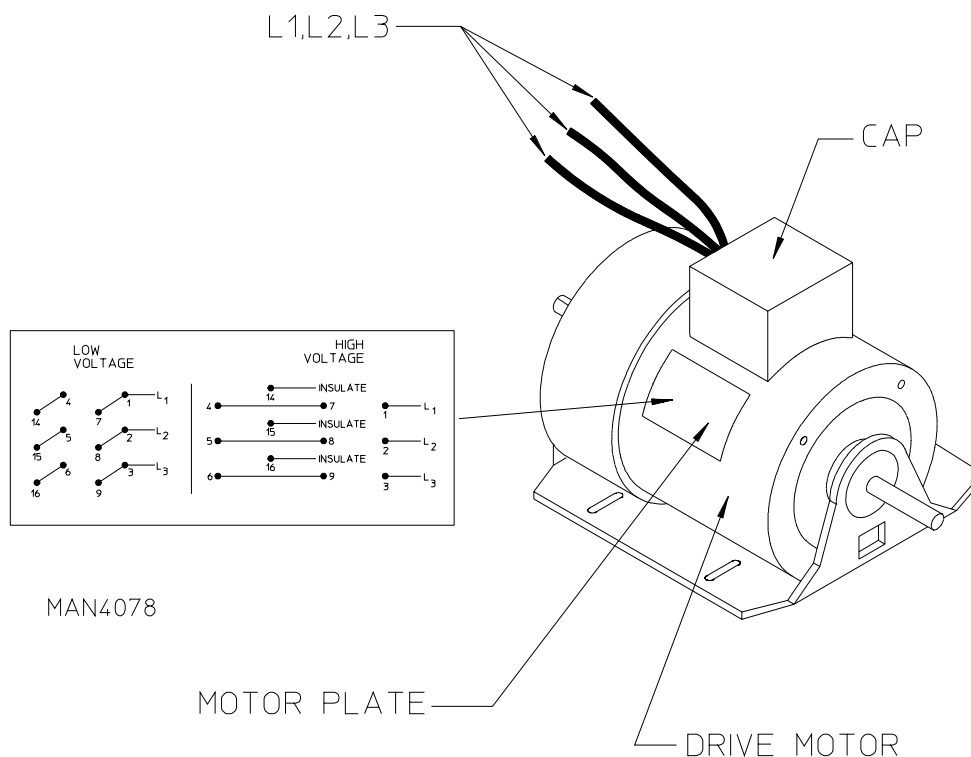

The motor plate is located on the side of the drive motor (refer to illustration) and contains a graphical representation of the motor wiring for both low and high voltage ratings.

Removing the cap reveals the wiring to the motor. On each wire there is a number which corresponds to the numbers on the motor plate. Depending on whether the dryer is operating on low or high voltage, the wiring should match the motor plate as follows:

The dots and lines represent connections (refer to illustration).

**For example:**

On low voltage - wire no. 14 is connected to wire no. 4

- wire no. 1 is connected to wire no. 7, which in turn are both connected to L1

On high voltage - wire no. 14 is insulated or capped

- wire no. 4 is connected to wire no. 7
- wire no. 1 is connected to L1

## B. DATA LABEL

Contacting **American Dryer Corporation (ADC)**

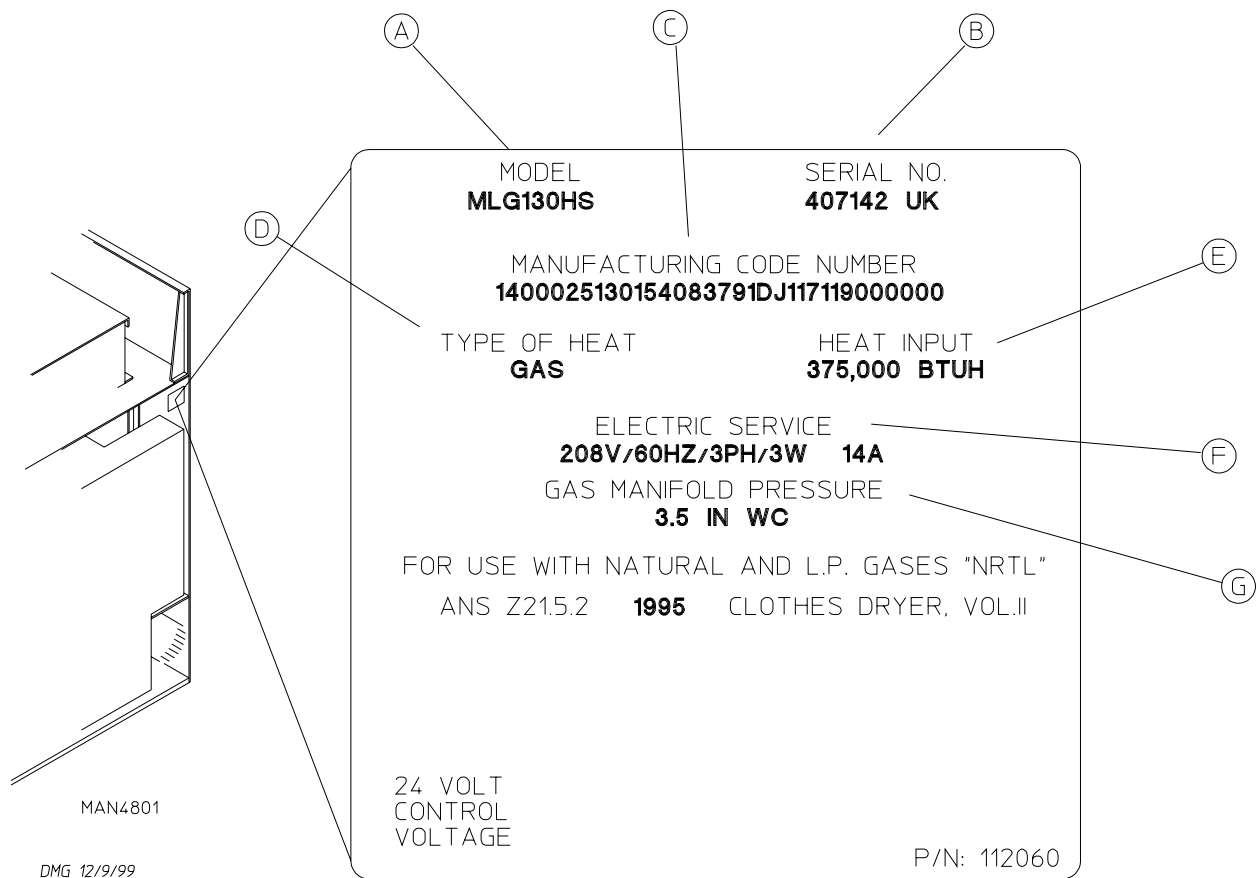

When contacting **ADC**, certain information is required to ensure proper service and parts information. This information is on the data label, located on the top right corner of the dryer, viewed from the rear (refer to illustration). When contacting **ADC**, please have the model number and serial number readily accessible.

### Information on the Data Label

- Model number - The model number is an **ADC** number which describes the size of the dryer and the type of heat (gas or steam).
- Serial number - The serial number allows **ADC** to gather information on your particular dryer.
- Manufacturing code number - The manufacturing code number is a number issued by **ADC** which describes **ALL** possible options on your particular model.
- Type of heat - Describes the type of heat; gas (natural or L.P. [liquid propane]), steam or electric.
- Heat input - (For gas dryers) describes the heat input in British Thermal Units.
- Electric service - Describes the electric service for your particular models.
- Gas manifold pressure - Describes the manifold pressure as taken at the gas valve pressure tap (refer to "Using a Manometer").

## C. HOW TO USE A MANOMETER

1. With dryer in nonoperating mode, remove plug on the gas valve pressure tap.
2. Attach plastic tubing to pressure tap. Fitting is supplied with manometer (refer to illustration).
3. Attach manometer to dryer using magnet.

**NOTE:** Place manometer in a position so that readings can be taken at eye level.

4. Fill manometer with water, as shown in illustration to the zero level.
5. Start dryer. With burner on, take a reading.
  - a. Read water level at the inner tube. Readings **should be** taken at eye level.
  - b. Correct readings **should be**:  
  
NATURAL GAS: 3.5 inches W.C. (8.7 mb).  
L.P. GAS: 10.5 inches W.C. (26.1 mb).
6. If water column pressure is incorrect refer to "TO ADJUST GAS PRESSURE."
7. Reverse procedure for removing manometer.

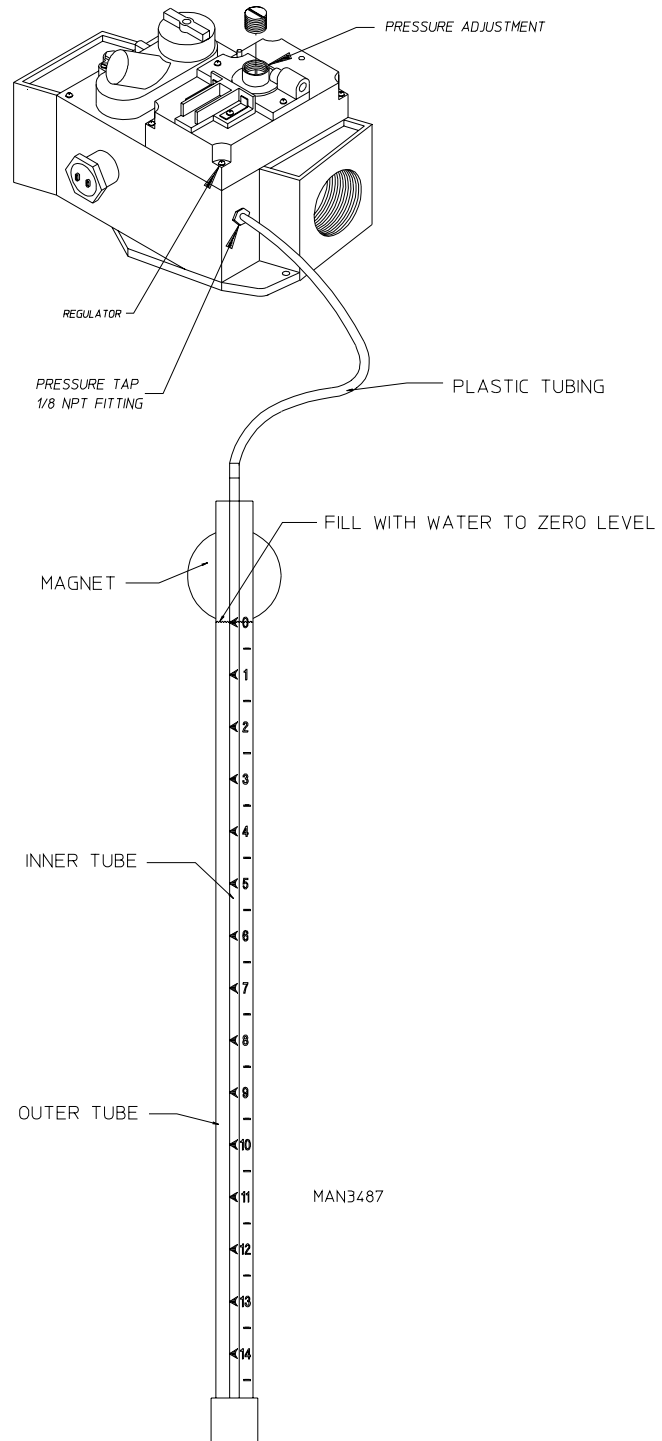

## D. TOOL LIST

Straight Head Screwdriver

Phillips Head Screwdriver

Sensor Pin and Socket Tool (P/N 122801)

Pliers

1/4" Nut Driver

3/8" Open End Wrench

5/8" Open End Wrench

3/8" Socket Wrench

1/2" Socket or Open End Wrench

1/4" Open End Wrench

5/16" Socket or Open Wrench

1/2" Socket Wrench

7/16" Socket or Open End Wrench

5/16" Nut Driver

12" Pipe Wrench (2)

1/8" "T" Shaped or "L" Shaped Allen Wrench

3/16" "T" Shaped or "L" Shaped Allen Wrench

Wire Cutters

1/2" Allen Wrench

3/8" Allen Wrench

Channel Locks

Manometer (**ADC** P/N 122804)

MP Pin Extraction Tool (**ADC** P/N 122800)



## Free Manuals Download Website

<http://myh66.com>

<http://usermanuals.us>

<http://www.somanuals.com>

<http://www.4manuals.cc>

<http://www.manual-lib.com>

<http://www.404manual.com>

<http://www.luxmanual.com>

<http://aubethermostatmanual.com>

Golf course search by state

<http://golfingnear.com>

Email search by domain

<http://emailbydomain.com>

Auto manuals search

<http://auto.somanuals.com>

TV manuals search

<http://tv.somanuals.com>