



EN

FR

ES

DVA-7996

FM/AM DVD Player

MP3

MX



**(((XM)))
READY**



- **OWNER'S MANUAL**
Please read before using this equipment.
- **MODE D'EMPLOI**
Veuillez lire avant d'utiliser cet appareil.
- **MANUAL DE OPERACIÓN**
Léalo antes de utilizar este equipo.

ALPINE ELECTRONICS, INC.
Tokyo office: 1-1-8 Nishi Gotanda,
Shinagawa-ku,
Tokyo 141-8501, Japan
Tel.: (03) 3494-1101

ALPINE ELECTRONICS OF AMERICA, INC.
19145 Gramercy Place, Torrance,
California 90501, U.S.A.
Tel.: 1-800-ALPINE-1 (1-800-257-4631)

ALPINE ELECTRONICS OF CANADA, INC.
7300 Warden Ave., Suite 203, Markham,
Ontario L3R 9Z6, Canada
Tel.: 1-800-ALPINE-1 (1-800-257-4631)

ALPINE ELECTRONICS OF AUSTRALIA PTY. LTD.
6-8 Fiveways Boulevard Keysborough,
Victoria 3173, Australia
Tel.: (03) 9769-0000

ALPINE ELECTRONICS GmbH
Kreuzerkamp 7, 40878 Ratingen,
Germany
Tel.: 02102-45 50

ALPINE ITALIA S.p.A.
Viale C. Colombo 8,
20090 Trezzano Sul Naviglio (MI), Italy
Tel.: 02-48 47 81

ALPINE ELECTRONICS FRANCE S.A.R.L.
(RCS PONTOISE B 338 101 280)
98, Rue de la Belle Etoile, Z.I. Paris
Nord II, B.P. 50016, 95945, Roissy
Charles de Gaulle Cedex, France
Tel.: 01-48 63 89 89

ALPINE ELECTRONICS OF U.K., LTD.
13 Tanners Drive, Blakelands,
Milton Keynes MK14 5BU, U.K.
Tel.: 01908-61 15 56

ALPINE ELECTRONICS DE ESPAÑA, S.A.
Portal de Gamarra 36, Pabellón, 32
01013 Vitoria (Alava) - APDO 133, Spain
Tel.: 945-283588

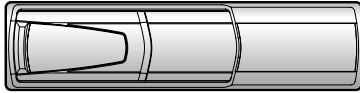

CHA-S634

- CD changer for DVA-7996
- Changeur CD pour le DVA-7996
- Cambiador de CD para el DVA-7996

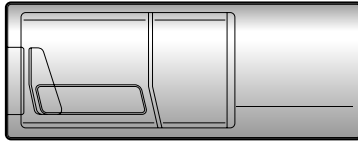

CHA-1214

- CD changer for DVA-7996
- Changeur CD pour le DVA-7996
- Cambiador de CD para el DVA-7996

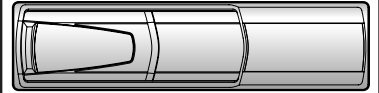

CHM-S630

Alpine CD Changers Give You More!

More musical selections, more versatility, more convenience.

The CHA-S634 is a high-performance 6-disc changer with a new M DAC, CD-R/RW PLAY BACK, MP3 PLAY BACK and CD TEXT. The CHA-1214 Ai-NET model holds 12 discs, and the CHM-S630 M-Bus model is a super-compact 6-disc changer with a CD-R/RW PLAY BACK.

Changeurs de CD Alpine : vous avez le choix!

Plus de sélections musicales, plus de souplesse, plus de confort.

Le modèle CHA-S634 est un changeur 6 disques ultra performant équipé des nouvelles fonctions M DAC, CD-R/RW PLAY BACK, MP3 PLAY BACK et CD TEXT. Le modèle CHA-1214 Ai-NET contient 12 disques. Le modèle CHM-S630 M-Bus est un changeur 6 disques super compact doté de la fonction CD-R/RW PLAY BACK.

¡Los cambiadores Alpine de CD le ofrecen más!

Más selecciones musicales, más versatilidad y más ventajas.

CHA-S634 es un cambiador de seis discos de alto rendimiento con nuevo M DAC, CD-R/RW PLAY BACK, MP3 PLAY BACK y CD TEXT. El modelo CHA-1214 Ai-NET alberga 12 discos y el modelo CHM-S630 M-Bus es un cambiador de seis discos de tamaño reducido con un CD-R/RW PLAY BACK.

Contents

Operating Instructions

WARNING

WARNING	3
CAUTION	3
PRECAUTIONS	3
Discs playable on this unit	5
Notes on Using Remote Control	6
Battery Replacement	6

Basic Operation

Detaching the Front Panel	7
Attaching the Front Panel	7
Initial System Start-Up	7
Turning Power On and Off	7
Display Angle Adjustment	7
Adjusting Volume/Balance (Between Left and Right)/Fader (Between Front and Rear)/Defeat	8
Audio Mute Function	8
Blackout Mode On and Off	8
Changing the Audio Level Display Pattern	8
Setting the Bass Control	9
Setting the Treble Control	9
Adjusting the Built-in Crossover	9
About the Time Correction	10
Bass Focus	11
Time Correction	12
Setting the MX Mode	12
Quick Searching Function	13
Displaying Time	13
Setting Time	13
Displaying the Title/Text	14
Titling Discs/Stations	15
Erasing Disc Title/Station Title	15

SETUP Operation

Setting the Sound Quality of the Tuner	16
Changing Lighting Color	16
Dimmer Control	16
Subwoofer On and Off	16
Sound (Beep) Guide Function	17
Scroll Setting	17
Setting the AUX Mode (V-Link)	17
Turning Mute Mode On/Off	17
Setting the External Input Defeat Mode	18
Demonstration	18
Setting the Digital Output	18
Optical Digital Input Selection for an External Audio Processor	18
Adjusting Display Contrast	18

Radio Operation

Manual Tuning	19
Automatic Seek Tuning	19
Manual Storing of Station Presets	19
Automatic Memory of Station Presets	19
Tuning to Preset Stations	19

CD Player Operation

Opening and Closing the Movable display	20
Playback	20
Music Sensor (Skip)	20
Fast Forward and Backward	20
Repeat Play	21
M.I.X. (Random Play)	21
Scanning Programs	21
Controlling CD Changer (Optional)	21
Multi-Changer Selection	22

MP3 Operation

Playing MP3 Files	23
Playing MP3 Files with the CD Changer (Optional)	23
Music Sensor (Skip)	23
Fast Forward and Backward	23
Selecting Folders	24
File Search	24
Repeat Play	24
M.I.X. (Random Play)	24
Scanning Programs	24
Setting the Range of MP3 File Selection	25
Playing MP3 Data	25
About MP3	25

XM Radio Operation

Receiving XM Channels with the XM Receiver (Optional)	27
Checking the XM Radio ID Number	27
Storing XM Channel Presets	28
Receiving Stored XM Channels	28
Category Search	28
Changing the Display	28

DVD/Video CD Operation

Playing DVD/Video CD	29
Stopping playback (PRE-STOP)	30
Stopping playback	30
Fast-forwarding/fast-reversing	30
Finding the beginnings of chapters or tracks ...	30
Playing still frames (pausing)	31
Frame-by-frame playback	31
Slow motion playback	31
Chapter/track/title repeat playback	31
Searching by title number	31
Searching directly by chapter or track number	32
Switching the angle	32
Switching the audio tracks	32
Switching the subtitles (subtitle language)	33

Displaying the disc status and changing the settings	33
Displaying the disc status and changing the settings	33
Rear DVD function	34
Remote control sensor selector	34

DVD Default Settings (SETUP)

Changing the language settings	35
Changing the TV screen settings	36
Changing the country code setting	37
Setting the rating level (parental lock)	38
Changing the down sampling setting	39
Changing the digital output setting	40

Operating DVDs and video CDs using the front panel	42
---	----

Remote Control Operation

Operating audio for the DVA-7996	43
Operating the DVD player/DVD changer (sold separately)	44
Operating the Navigation (sold separately)	45
Operating a sold separately TV monitor	45

Information

About DVDs	46
Terminology	47
List of language codes	48
List of country codes	49
In Case of Difficulty	51
Specifications	54

Installation and Connections

Warning	55
Caution	55
Precautions	55
Installation	56
Connections	57
System Example	59

WARNING

WARNING

This symbol means important instructions. Failure to heed them can result in serious injury or death.

DO NOT OPERATE ANY FUNCTION THAT TAKES YOUR ATTENTION AWAY FROM SAFELY DRIVING YOUR VEHICLE.

Any function that requires your prolonged attention should only be performed after coming to a complete stop. Always stop the vehicle in a safe location before performing these functions. Failure to do so may result in an accident.

KEEP THE VOLUME AT A LEVEL WHERE YOU CAN STILL HEAR OUTSIDE NOISE WHILE DRIVING.

Failure to do so may result in an accident.

MINIMIZE DISPLAY VIEWING WHILE DRIVING.

Viewing the display may distract the driver from looking ahead of the vehicle and cause an accident.

DO NOT DISASSEMBLE OR ALTER.

Doing so may result in an accident, fire or electric shock.

USE ONLY IN CARS WITH A 12 VOLT NEGATIVE GROUND.

(Check with your dealer if you are not sure.) Failure to do so may result in fire, etc.

KEEP SMALL OBJECTS SUCH AS BATTERIES OUT OF THE REACH OF CHILDREN.

Swallowing them may result in serious injury. If swallowed, consult a physician immediately.

USE THE CORRECT AMPERE RATING WHEN REPLACING FUSES.

Failure to do so may result in fire or electric shock.

DO NOT BLOCK VENTS OR RADIATOR PANELS.

Doing so may cause heat to build up inside and may result in fire.

USE THIS PRODUCT FOR MOBILE 12V APPLICATIONS.

Use for other than its designed application may result in fire, electric shock or other injury.

DO NOT PLACE HANDS, FINGERS OR FOREIGN OBJECTS IN INSERTION SLOTS OR GAPS.

Doing so may result in personal injury or damage to the product.

CAUTION

This symbol means important instructions. Failure to heed them can result in injury or material property damage.

HALT USE IMMEDIATELY IF A PROBLEM APPEARS.

Failure to do so may cause personal injury or damage to the product. Return it to your authorized Alpine dealer or the nearest Alpine Service Center for repairing.

DO NOT MIX NEW BATTERIES WITH OLD BATTERIES. INSERT WITH THE CORRECT BATTERY POLARITY.

When inserting the batteries, be sure to observe proper polarity (+ and -) as instructed. Rupture or chemical leakage from the battery may cause fire or personal injury.

KEEP FINGERS AWAY WHILE THE MOTORIZED FRONT PANEL OR MOVING MONITOR IS IN MOTION.

Failure to do so may result in personal injury or damage to the product.

PRECAUTIONS

Temperature

Be sure the temperature inside the vehicle is between +60°C (+140°F) and -10°C (+14°F) before turning your unit on.

Moisture Condensation

You may notice the disc playback sound wavering due to condensation. If this happens, remove the disc from the player and wait about an hour for the moisture to evaporate.

Damaged Disc

Do not attempt to play cracked, warped, or damaged discs. Playing a bad disc could severely damage the playback mechanism.

Maintenance

If you have problems, do not attempt to repair the unit yourself. Return it to your Alpine dealer or the nearest Alpine Service Station for servicing.

⚠ WARNING

⚠ PRECAUTIONS

Never Attempt the Following

Do not grip or pull out the disc while it is being pulled back into the player by the automatic reloading mechanism.

Do not attempt to insert a disc into the unit when the unit power is off.

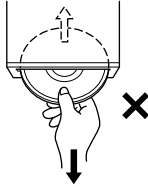

Inserting Discs

Your player accepts only one disc at a time for playback. Do not attempt to load more than one disc.

Make sure the label side is facing up when you insert the disc. Your player will automatically eject any disc that is inserted incorrectly. If the player continues to eject a correctly inserted disc, push the RESET switch with a pointed object such as a ballpoint pen.

Playing a disc while driving on a very bumpy road may result in skips, but this will not scratch the disc or damage the player.

New Discs

As a protective measure to prevent the Disc from jamming, the DVD player will automatically eject discs with irregular surfaces or inserted incorrectly. When a new disc is inserted into the player and ejected after initial loading, using your finger, feel around the inside of the centre hole and outside edge of the disc. If you feel any small bumps or irregularities, this could inhibit proper loading of the disc. To remove the bumps, rub the inside edge of the hole and outside edge of the disc with a ballpoint pen or other such instrument, then insert the disc again.

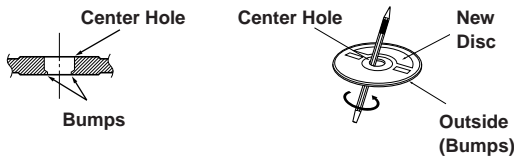

Irregular Shaped Discs

Be sure to use round shape discs only for this unit and never use any special shape discs.

Use of special shape discs may cause damage to the mechanism.

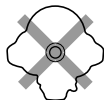

Installation Location

Make sure the DVA-7996 will not be installed in a location subjected to:

- Direct sun and heat
- High humidity and water
- Excessive dust
- Excessive vibrations

Correct Handling

Do not drop the disc while handling. Hold the disc so you will not leave fingerprints on the surface. Do not affix tape, paper, or gummed labels to the disc. Do not write on the disc.

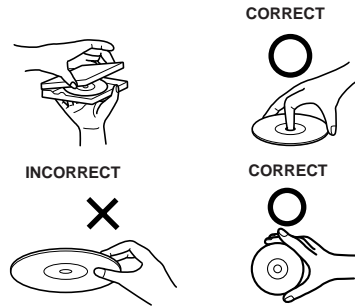

Disc Cleaning

Fingerprints, dust, or soil on the surface of the disc could cause the DVD player to skip. For routine cleaning, wipe the playing surface with a clean, soft cloth from the centre of the disc to the outer edge. If the surface is heavily soiled, dampen a clean, soft cloth in a solution of mild neutral detergent before cleaning the disc.



Disc Accessories

There are various accessories available on the market for protecting the disc surface and improving sound quality. However, most of them will influence the thickness and/or diameter of the disc. Using such accessories can cause the disc to be out of standard specifications and may create operational problems. We recommend not using these accessories on discs played in Alpine DVD players.

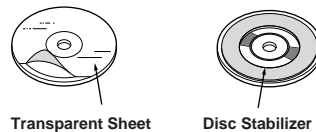

Discs playable on this unit

• Playable discs

The discs listed below can be played on this DVD head unit.

	Mark (logo)	Recorded content	Disc size	Max. playing time
DVD Video		Audio + Video (Moving pictures)	12 cm*	One-sided disc Approx. 4 hours
				Two-sided disc Approx. 8 hours
			8 cm	One-sided disc Approx. 80 Minutes
				Two-sided disc Approx. 160 Minutes
Video CD		Audio + Video (Moving pictures)	12 cm	Approx. 74 Minutes
			8 cm	Approx. 20 Minutes
Music CD	 	Audio	12 cm	Approx. 74 Minutes
			8 cm (CD single)	Approx. 20 Minutes

* Two-layer DVD disc compatible

You can play CD-Rs (CD-Recordable)/CD-RWs (CD-ReWritable) for audio use on this unit. You can also play CD-Rs/CD-RWs containing MP3 formatted audio files.

- Some of the following Discs may not play on this unit: Flawed Discs, Discs with fingerprints, Discs exposed to extreme temperatures or sunlight (e.g., left in the car or this unit), Discs recorded under unstable conditions, Discs on which a recording failed or a re-recording was attempted.
- Use discs with MP3 files written in the format compliant with ISO 9660 level 1 or level 2. For details, see pages 25, 26.

On handling Compact Discs (CD/CD-R/CD-RW)

- Do not touch the surface.
- Do not expose the disc to direct sunlight.
- Do not affix stickers or labels and do not write on the surface.
- Clean the disc when it is dusty.
- Make sure that there are no bumps around the disc.
- Do not use commercially available disc accessories.

Do not leave the disc in the car or the unit for a long time. Never expose the disc to direct sunlight. Heat and humidity may damage the disc and you may not be able to play it again.

• Discs that cannot be played

DVD-ROMs, DVD-R/DVD-RAMs, DVD-RWs, DVD + RWs, CD-ROMs (excluding MP3 files), photo CDs, etc.

• DVD region number (playable region number)

This DVD head unit will play back any disc whose region number is 1 (or All). DVDs with a region number other than those listed below, cannot be played on this DVD player.



• Video CDs

This DVD head unit is compatible with playback control (PBC) compatible video CDs (version 2.0).

“PBC” is a function by which you can use menu screens recorded on the disc to find the scene you want to watch and view various types of information in dialog style.

• Disc terminology

Title

If titles are programmed for the DVD, these are the largest unit of division of the information recorded on the disc.

Chapter

Each Title may also be divided into smaller divisions called Chapters. These can be specific scenes or musical selections.

- * *This product incorporates copyright protection technology that is protected by method claims of certain U.S. patents and other intellectual property rights owned by Macrovision Corporation and other rights owners. Use of this copyright protection technology must be authorized by Macrovision Corporation, and is intended for home and other limited viewing uses only unless otherwise authorized by Macrovision Corporation. Reverse engineering or disassembly is prohibited.*

- * *Manufactured under license from Dolby Laboratories. “Dolby”, “Pro Logic” and the double-D symbol are trademarks of Dolby Laboratories. Confidential unpublished works. ©1992-1997 Dolby Laboratories. All rights reserved.*

- * *“DTS” and “DTS Digital Out” are trademarks of Digital Theater Systems, inc.*

Notes on Using Remote Control

Point the remote control transmitter at the remote control sensor.

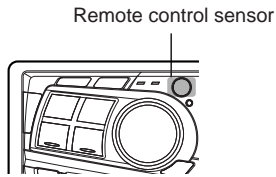

- Point the remote control at the remote sensor within about 2 meter.
- It may not be possible to operate the remote control unit if the remote control sensor is exposed to direct sunlight.
- The remote control is a small, light weight precision device. To avoid damage, short battery life, operational errors and poor button response, observe the following.
 - Do not apply any shock.
 - Do not put in a trouser pocket.
 - Keep away from food, moisture and dirt.
 - Do not place in direct sunshine.

Warning

DO NOT OPERATE ANY FUNCTION THAT TAKES YOUR ATTENTION AWAY FROM SAFELY DRIVING YOUR VEHICLE.

Any function that requires your prolonged attention should only be performed after coming to a complete stop. Always stop the vehicle in a safe location before performing these functions. Failure to do so may result in an accident.

Battery Replacement

Applicable battery: Use two "AAA" sized dry batteries or equivalent.

- 1** Opening the battery cover.
Push on the cover and slide it as indicated by the arrows then the cover will be removed.

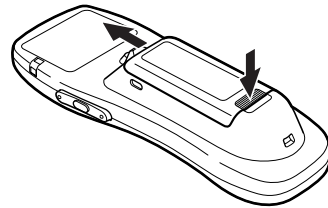

- 2** Replacing the battery.
Put the batteries in the case observing the polarities as illustrated.

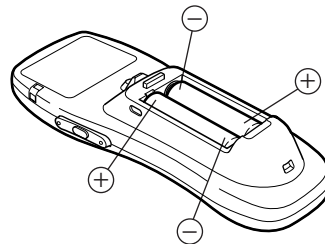

- 3** Closing the cover.
Push the cover in the arrow direction until a click is heard.

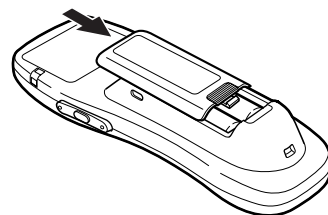

Basic Operation

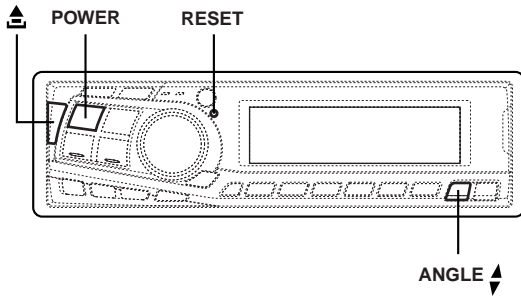

The DVA-7996 can be operated using both the buttons on the main unit and the included remote control unit (except for some operations). The section on audio operations (excluding DVD and video CD operations) mainly describes operations using the buttons on the main unit. For instructions on performing operations using the remote control unit, see page 43.

Detaching the Front Panel

- 1 Press and hold the **POWER** button for more than 3 seconds to turn off the power.
- 2 Press the  (Release) button at upper left side until the front panel pops out.
- 3 Grasp the left side of the front panel and pull it out.

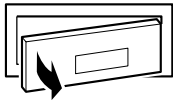

NOTES

- The front panel may become hot in normal usage (especially the connector terminals on the back of the front panel.) This is not a malfunction.
- To protect the front panel, place it in the supplied carrying case.

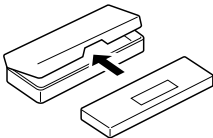

Attaching the Front Panel

- 1 First, insert the right side of the front panel into the main unit. Align the groove on the front panel with the projections on the main unit.
- 2 Push the left side of the front panel until it locks firmly into the main unit.

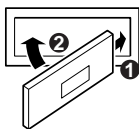

NOTES

- Before attaching the front panel, make sure that there is no dirt or dust on the connector terminals and no foreign object between the front panel and the main unit.
- Attach the front panel carefully by holding the sides of the front panel. This will help you to avoid pushing buttons by mistake.

Initial System Start-Up

Be sure to press the **RESET** switch when using the unit for the first time, after installing the CD changer, etc., or after changing the car battery.

- 1 Make sure that the power of the unit is off. If the power is on, press and hold the **POWER** button for at least 3 seconds to turn off the unit.
- 2 Press the **RESET** switch with a ballpoint pen, or any other pointed object.

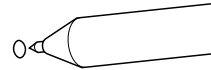

Turning Power On and Off

- 1 Press the **POWER** button to turn on the unit.

NOTE

The unit can be turned on by pressing any other button except the eject  and **CLK/TITLE** button.

The volume level gradually increases to the previous level you were listening to before the unit was turned off. Press and hold the **POWER** button for at least 3 seconds to turn off the unit.

NOTE

The first time power is turned on, the volume will start from level 12.

Display Angle Adjustment

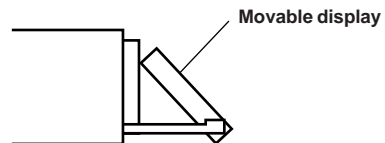

The movable display may be adjusted to 3 different angles depending upon user preference.

- 1 Press the **ANGLE**   button to adjust the angle of the movable display.

NOTES

- The adjusted angle of the display is stored in memory. There is no need to re-adjust the angle when the power is turned back on.
- When the display is fully opened, if you turn off the ignition key, after a while, the display will close fully. However, the display will not fully close when the angle of the display has been already stored in memory.

CAUTION

Keep hands (or any other object) away from the display while it is opening or closing to avoid damage or injury. The back of the movable display will get very warm under normal operating conditions. This is not a malfunction. Do not touch.

Basic Operation

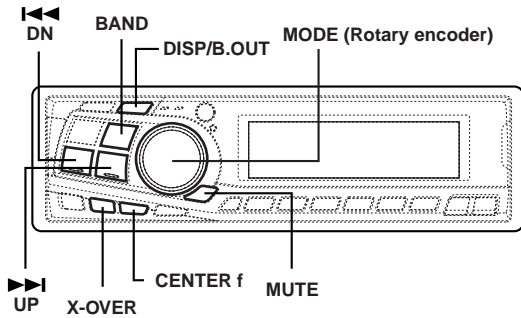

Adjusting Volume/Balance (Between Left and Right)/Fader (Between Front and Rear)/Defeat

- 1 Press the **MODE (Rotary encoder)** button repeatedly to choose the desired mode.

Each press changes the modes as follows:

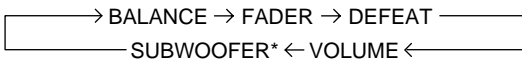

Volume : 0 ~ 35

Balance : L15 ~ R15

Fader: R15 ~ F15

Subwoofer: 0 ~ +15

NOTES

- If the **MODE** button is not pressed within 5 seconds after selecting the **BALANCE**, **FADER**, **DEFEAT** or **SUBWOOFER** mode, the unit automatically returns to the **VOLUME** mode.
- *When subwoofer mode is **OFF** or when **LINK** (rear DVD function (page 34) is set to **ON**), its level cannot be adjusted.

- 2 Turn the **Rotary encoder** until the desired sound is obtained in each mode.
By setting Defeat ON, previously adjusted settings of BASS, TREBLE will return to the factory defaults, but MX will be turned off.

NOTE

Depending on the connected devices, some functions and display indications do not work.

Audio Mute Function

Activating this function will instantly lower the volume level by 20 dB.

- 1 Press the **MUTE** button to activate the MUTE mode. The audio level will decrease by about 20 dB. Pressing the **MUTE** button again will bring the audio back to its previous level.

Blackout Mode On and Off

When the Blackout mode is turned on, the display will turn off to reduce power consumption. This additional power enhances the sound quality.

- 1 Press and hold the **B.OUT** button for at least 3 seconds to start the blackout mode. By doing so the display will turn off.

NOTE

If any button on the unit is pressed during the blackout mode, the function will be displayed for 5 seconds to show the operation before returning to Blackout mode.

To cancel the blackout mode, press and hold the **B.OUT** button for at least 3 seconds.

Changing the Audio Level Display Pattern

You can select the Audio Level Display from three display patterns.

- 1 Press **DISP** button to switch the display pattern.

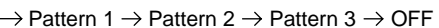

Setting the Bass Control

You can change the Bass Frequency emphasis to create your own tonal preference.

- 1 Press the **CENTER f** button to select the BASS (bass Center frequency) control mode.

→ BASS → TREBLE → normal mode ←

- 2-1 Setting the bass Center frequency:

Press the **◀ DN** or **▶ UP** button to select the desired bass center frequency.

→ 60Hz ↔ 70Hz ↔ 80Hz ↔ 90Hz ←
→ 180Hz ↔ 150Hz ↔ 130Hz ↔ 100Hz ←

Emphasizes the displayed Bass frequency ranges.

- 2-2 Setting the bass Band Width (Q-Factor):

Press the **BAND** button to select the desired bass Band Width.

→ B. Width1 → B. Width2 → B. Width3 → B. Width4
(Wide) ← → (Narrow)

Changes the bass boost band width to wide or narrow. A wide setting will boost a wide range of frequencies above and below the center frequency. A narrower setting will boost only frequencies near the center frequency.

- 2-3 Setting the bass Level:

Turn the **Rotary encoder** to select the desired bass Level (-7~+7).

You can emphasize or weaken the bass frequency.

NOTES

- If no buttons are pressed within 15 seconds, the Bass control setting will be turned off automatically.
- The settings of the Bass Level will be individually memorized for each source (FM, AM, XM, CD, etc.) until the setting is changed. Once you set Bass frequency and Bass Band Width for one of sources (FM, AM, XM, CD, etc.), this setting becomes effective for all those sources. Depending on the connected devices, some functions and display indications do not work.
- This function is inoperable when DEFEAT is ON.

Setting the Treble Control

You can change the Treble Frequency emphasis to create your own tonal preference.

- 1 Press the **CENTER f** button to select the TREBLE (treble Center frequency) control mode.

→ BASS → TREBLE → normal mode ←

- 2-1 Setting the treble Center frequency:

Press **◀ DN** or **▶ UP** button to select the desired treble Center frequency.

→ 10.0kHz ↔ 12.5kHz ↔ 15.0kHz ↔ 17.5kHz ←

Emphasizes the displayed Treble frequency ranges.

- 2-2 Setting the treble Level:

Turn the **Rotary encoder** to select the desired Treble Level (-7~+7).

You can emphasize the treble frequency.

NOTES

- If no buttons are pressed within 15 seconds, the Treble control setting will be turned off automatically.
- The settings of the Treble Level will be individually memorized for each source (FM, AM, XM, CD, etc.) until the setting is changed. Once you set Treble frequency for one of sources (FM, AM, XM, CD, etc.), this setting becomes effective for all those sources. Depending on the connected devices, some functions and display indications do not work.
- This function is inoperable when DEFEAT is ON.

Adjusting the Built-in Crossover

The High and Low Pass Filters on this unit can be adjusted to suit your personal taste.

- 1 Press and hold the **X-OVER** button for at least 2 seconds.

→ HPF — <Press momentarily> → LPF* — <Press momentarily>
— <Press for at least 2 seconds> — normal mode ←

* When the subwoofer output of this unit is turned OFF, LPF and phase are deactivated.

- 2 Press the **◀ DN** or **▶ UP** button to select the desired setting.

1. HPF (Setting the High Pass Filter):

FLAT (OFF) ↔ 80Hz ↔ 120Hz ↔ 160Hz

Outputs all frequencies higher than that selected according to your preference.

2. LPF (Setting the Low Pass Filter):

FLAT (OFF) ↔ 80Hz ↔ 120Hz ↔ 160Hz

Outputs all frequencies lower than that selected according to your preference. (Only available when using the subwoofer output from this unit.)

NOTES

- If no buttons are pressed within 15 seconds, the setup menu returns to the normal audio display.
- These functions are inoperative when an external, Ai-NET processor is connected.
- If HPF, LPF, Bass Control and Treble Control are all set to ON, depending on the Bass Control and Treble Control settings, you may not be able to reinforce the sound effect.
- Except when the HPF and LPF is turned OFF, the subwoofer is in monaural mode.
- When the subwoofer is set to OFF, LPF mode and change of phase does not work.

Basic Operation

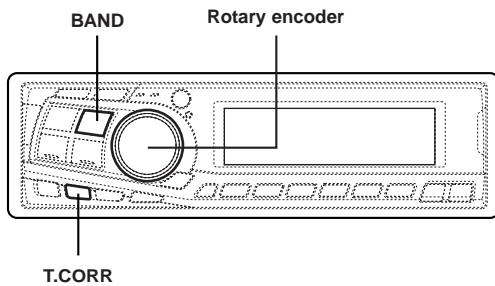

Here we calculate the time correction value for the front left speaker in the diagram at the left.

Conditions:

Farthest Speaker – listening position : 2.25 m (88-9/16")

Front left speaker – listening position : 0.5 m (19-11/16")

Calculation: $L = 2.25 \text{ m} - 0.5 \text{ m} = 1.75 \text{ m} (68-7/8")$

Time correction = $1.75 \div 343^* \times 1000 = 5.1 \text{ (ms)}$

*Speed of sound: 343 m/s (765 mph) at 20°C

In other words, giving the front left speaker a time correction value of 5.1 ms makes it seem as if the distance to the front left speaker is the same as the distance to the farthest speaker.

The sound is not balanced because the distance between the listening position and the various speakers is different. The difference in distance between the front left speaker and the rear right speaker is 1.75 m (68-7/8").

Time correction eliminates the differences in the time required for the sound to reach the listening position. The time of the front left speaker is corrected by 5.1 ms so that its sound reaches the listening position at the same time as the sound of other speakers.

About the Time Correction

The distance between the listener and the speakers in a car vary widely due to the special conditions of the mobile environment. This difference in the distances from the speakers to the listener creates a shift in the sounds image and frequency characteristics. This is caused by the time delay between the sound reaching the listener's right versus the left ear.

To correct this, the DVA-7996 is able to delay the audio signal to the speakers closest to the listener. This effectively creates a perception of increased distance for those speakers. The listener can be placed at an equal distance between the left and right speakers for optimum staging. The adjustment will be made for each speaker in a step of 0.1 ms.

Example 1. Listening Position: Front Left Seat

Adjust the time correction level of the front left speaker to a high value and the rear right to zero or a low value.

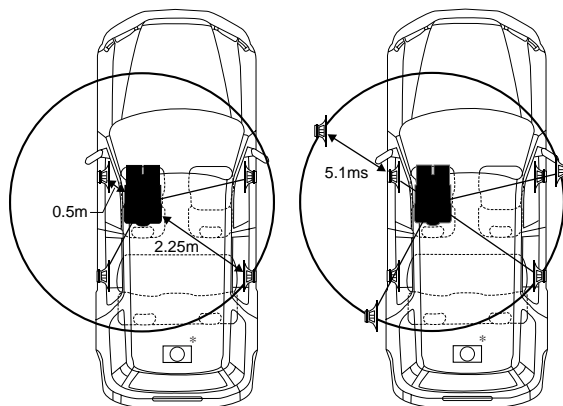

Tips

* Subwoofer speaker

You cannot change the Time Correction value for the subwoofer, but you can set the subwoofer's apparent position to the front by adjusting the Time Correction value of the front and rear speakers.

For details, refer to the "Tips" on page 11.

Example 2. Listening Position: All Seats

Adjust the time correction level of each speaker to almost the same level.

- 1 Sit in the listening position (driver's seat, etc.) and measure the distance (in meters) between your head and the various speakers.
- 2 Calculate the difference between the distance to the farthest speaker and the other speakers.
 $L = (\text{distance to farthest speaker}) - (\text{distance to other speakers})$
- 3 Divide the distances calculated for the speakers by the speed of sound (343 m/s (765 mph) at 20°C). These values are the time correction values for the different speakers.

Bass Focus

The time difference between the front-rear/left-right speakers, can be adjusted at the same time. With an initial delay of 0.1 ms for each of the 0 to 99 steps, audible time correction can be done.

- 1 Press the **T.CORR** button to select the Bass Focus mode.

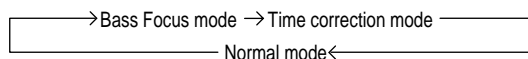

- 2 Press the **BAND** button to select the front-rear / left-right speakers.

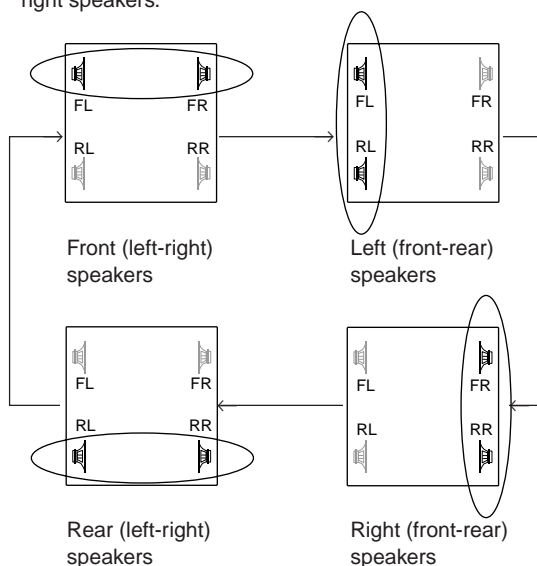

- 3 Turn the **Rotary encoder** to adjust the front-rear / left-right delay.
- 4 For setting another channel (speaker), repeat the steps 2 and 3.
- 5 After setting, press the **T.CORR** to return to the normal mode.

NOTES

- Any manual time correction adjustments will also affect corrections made in Bass Focus.
- Time Correction mode is automatically canceled if no buttons are pressed within 15 seconds.

Example of Steps 2 and 3 Setting

- (1) After entering corrections for the front (left and right) speakers in STEP 15, the time difference is 1.5 ms for both front-left and front-right speakers.

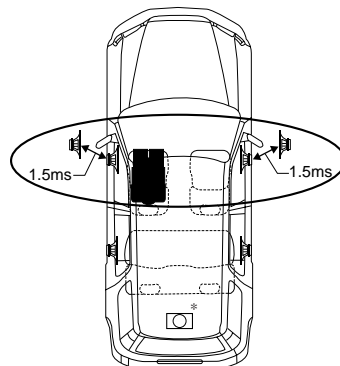

- (2) After entering corrections for the left (front and rear) speakers in STEP 15, the time difference becomes 3.0 ms* for the front left speaker and 1.5 ms for the left rear speaker.

* Because the time difference was already set to 1.5 ms for the front left speaker in STEP 1, the additional correction in STEP 15 makes the time difference of the front left speaker 3.0 ms.

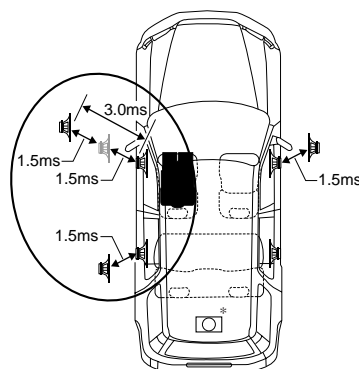

Tips

* Subwoofer speaker

Delay (turn the rotary encoder) the audio signal to the front (left and right) speakers to make the apparent position of the subwoofer to be at the front. In doing this, the apparent position between the front (left and right) speakers and subwoofer will appear equal to the driver. After performing above, you can change the positions of left and right speakers by delaying the time.

Continued

11-EN

Basic Operation

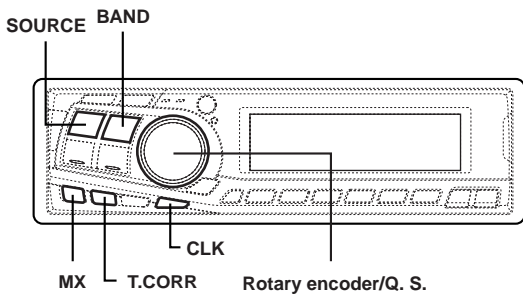

Time Difference Table

Number of Steps	Time Difference (ms)	Number of Steps	Time Difference (ms)	Number of Steps	Time Difference (ms)
0	0.0	14	1.4	28	2.8
1	0.1	15	1.5	29	2.9
2	0.2	16	1.6	30	3.0
3	0.3	17	1.7	31	3.1
4	0.4	18	1.8	32	3.2
5	0.5	19	1.9	33	3.3
6	0.6	20	2.0	34	3.4
7	0.7	21	2.1	35	3.5
8	0.8	22	2.2	36	3.6
9	0.9	23	2.3	37	3.7
10	1.0	24	2.4	38	3.8
11	1.1	25	2.5	39	3.9
12	1.2	26	2.6	40 - 98	4.0 - 9.8
13	1.3	27	2.7	99	9.9

Time Correction

Before performing the following procedures, refer to "About the Time Correction" (page 10).

1 Make time corrections by pressing the **T.CORR** button.

Each press changes the modes as follows:

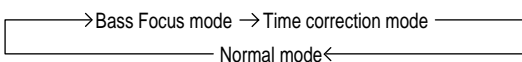

2 Select a speaker to be adjusted by pressing the **BAND** button.

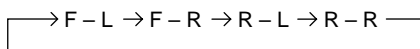

3 Adjust the desired time correction value by turning the **Rotary encoder**.

4 For setting another speaker, repeat the step 2 and 3.

5 After setting, press the **Rotary encoder** to return to the normal mode.

NOTE

Time Correction mode is automatically canceled if no buttons are pressed within 15 seconds.

Setting the MX Mode

MX (Media Xpander) makes vocals or instruments sound distinct regardless of the music source. The radio, CD, and MP3, will be able to reproduce the music clearly even in cars with a lot of road noise.

- 1 Press the **MX** button to select MX ON.
- 2 Press the **SOURCE** button to select the source you want to MX (Media Xpander)-correct.
- 3 Press and hold the **MX** button for at least 2 seconds to select the MX mode.
- 4 Turn the **Rotary encoder** to select your preferred mode or OFF.

FM (MX level 1 to 3):

The medium to high frequencies become more clear, and produces well balanced sound in all the bands.

CD (MX level 1 to 3):

CD mode processes a large quantity of data. This data is used to reproduce the sound cleanly by making use of the data quantity.

MP3/XM (MX level 1 to 3):

This corrects information that was omitted at the time of compression. This reproduces a well-balanced sound close to the original.

DVD (or Video CD):

- (MOVIE MX level 1 to 2)

The dialog portion of the video is reproduced more clearly.

- (MUSIC MX level 1)

This disk contains a large quantity of data such as music clip. MX uses this data to reproduce the sound accurately.

AUX (MX level 1):

Choose the MX mode (MP3, MUSIC, or MOVIE) that corresponds to the media connected.

5 After setting, press the **Rotary encoder** to return to the normal mode.

NOTES

- By "Setting the External Input Defeat Mode" (page 18) to ON, operation is bypassed.
- To cancel MX mode for all music sources, press the **MX** button to turn MX off.
- MX mode is automatically canceled if no buttons are pressed within 15 seconds.
- Each music source, such as radio, CD, and MP3 can have its own MX setting.
- Setting to MX OFF makes MX mode of each music source OFF.
- This function is inoperable when DEFEAT is ON.
- MX mode does not function when MX is ON for AM radio.

Quick Searching Function

You can easily select tracks and files.

- 1 Press the **SOURCE** button to set the desired source mode.
(CD mode is explained here as an example)
- 2 When setting the CD mode, press and hold the **Q.S.** button for at least 2 seconds. The mode changes to the Q.S. (Quick Search) setting.
- 3 Select a desired track by turning the **Rotary encoder** to the right or left.
 - CD/Changer mode: Track can be selected.
 - XM mode: Channel can be selected. (It is not possible to select in the FM/AM tuner mode)
 - MP3 mode: File number can be selected.
- 4 When the setting is completed, the Q.S. mode is canceled by pressing the **Rotary encoder**.

NOTE

The Q.S. mode is automatically canceled after 10 seconds if no buttons are pressed during step 2 and 3.

Displaying Time

- 1 Press the **CLK** (clock) button repeatedly until the time is displayed.

Each press changes the modes as follows:

Radio mode

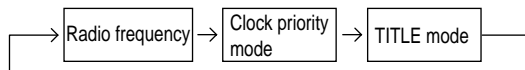

CD Player/Changer modes

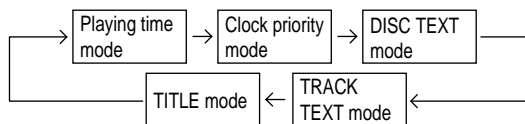

NOTES

- Selecting any tuner or CD function while in the clock priority mode will interrupt the time display momentarily. The function selected will be displayed for about 5 seconds before the time returns to the display.
- When the power is off but the ignition key is on, press the **CLK** button to display the time.

Setting Time

- 1 In the Clock priority mode, press and hold the **CLK** (clock) button for at least 3 seconds while the time is displayed. The time indication will blink.
- 2 Turn the **Rotary encoder** to adjust the hours while the time indication is blinking.
- 3 When the hour has been adjusted, press the **Rotary encoder**.
- 4 Turn the **Rotary encoder** to adjust the minutes while the time indication is blinking. The time is automatically set 5 seconds after the minute adjustment. The time can also be manually set by pressing the **Rotary encoder**.

Basic Operation

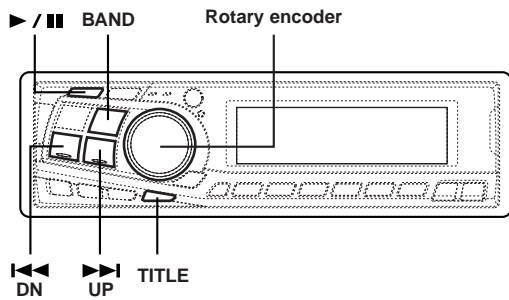

Displaying the Title/Text

It is possible to display the Disc/Station on the audio display if the title has been previously inputted. For details, see "Titling Disc/Stations" (page 15). Text information, such as the disc name and the track name, will be displayed if playing a CD text compatible disc. It is also possible to display the folder name, the file name, and the ID3 tag, etc. while playing MP3 files.

- 1 Press the **TITLE** button.
The mode will change every time the button is pressed.

About "Title" and "Text"

Title: With this device, it is possible to input the CD/DVD/Video CD/Station name (refer to page 15). This inputted name is referred to as a "title."

You cannot input or display titles on MP3 discs.

Text: Text compatible CDs contain text information such as the disc name and track name. Such text information is referred to as "text."

Radio mode:

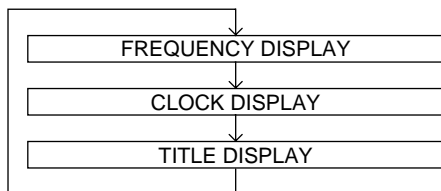

CD mode:

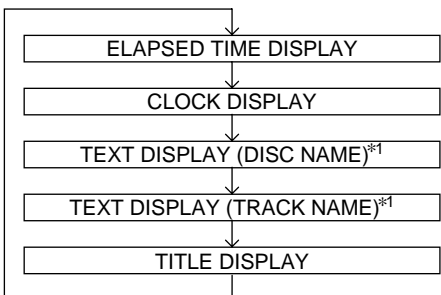

MP3 mode:

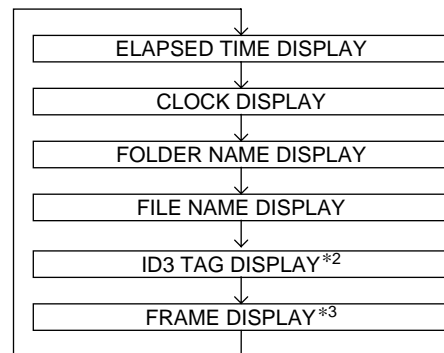

DVD/Video CD mode:

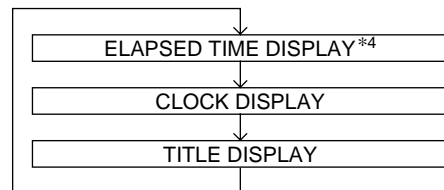

- *1 Displayed during playback of a disc with CD Text. "NO TEXT" will be displayed when the CD contains no Text data.
- *2 If an MP3 file contains ID3 tag information, all the ID3 tag information is displayed (e.g., track name, artist name, and album name). All other tag data is ignored. "NO TAG" will be displayed when an MP3 file contains no ID3 tag information.
- *3 The recording sampling rate and bit rate of the MP3 file are displayed.
- *4 The playback elapsed time is displayed for video CD with the PBC function when PBC OFF is set.

NOTES

- Some characters may not be displayed correctly with this device, depending on the character type.
- The CD changer must also be CD Text compatible for the Text information to be displayed.
- When the Scroll Setting (refer to page 17) is set to "SCR MANUAL", press and hold the TITLE button for at least 3 seconds to scroll the Text information only once (TEXT DISPLAY, FOLDER NAME DISPLAY, FILE NAME DISPLAY or ID3 TAG DISPLAY mode).
- "NO SUPPORT" is displayed when the desired text information cannot be displayed on this unit.
- If the title was not previously input, "NO TITLE" is displayed.
- The operations to display the title/text and to select the title input operation cannot be performed using the TITLE button on the remote control unit.

Titling Discs/Stations

It is possible to title your favorite Disc's (CD, DVD, Video CD) or radio stations.

You cannot input titles on MP3 discs.

- 1 Press the **TITLE** button and select the title display mode.
For details, see "Displaying the Title/Text" (page 14).
- 2 Press and hold the **TITLE** button for at least 3 seconds. The first character will blink.
Press the **BAND** button to select the characters/symbols.

→ Upper case → Lower case → Numeral/Symbol
- 3 Turn the **Rotary encoder** to select the desired letter/numeral/symbol available for naming.
- 4 Press the **Rotary encoder** to store the first character. The first character will stop blinking and the display will automatically advance to the next character. When that character begins to blink, you may choose the next letter or symbol of your title.
- 5 Repeat the steps 3 and 4 above to complete the titling. Pressing the **Rotary encoder** after entering the 8th character, automatically stores the title into memory.

When entering a title of less than 8 characters (for example, 3 character title):
After entering 3 characters to complete your title, the 4th character space will be blinking. Go to step 6 to complete the title.
- 6 Press the **TITLE** button to record the title.

NOTES

- You can enter 24 radio station titles and 18 Disc titles on this unit. If you try to store beyond the limit, the audio display will show "FULL DATA". At this point, no more titles can be stored.
- The CD Changer title length or memory capacity varies depending upon the model being used.
- To input a new title, one of the previously inputted titles must first be deleted.
- When you want to erase a title, enter the "⏏" symbol into all spaces.
- The operations described in steps 3 to 5 must be made within 10 seconds. The input mode will be cancelled if no action is taken for over 10 seconds.
- Removing power from the unit may delete these titles. Use caution when manipulating the power cord.

Erasing Disc Title/Station Title

- 1 Press the **TITLE** button to select the titling mode. Then, press and hold for at least 3 seconds.
- 2 Press and hold the **▶/||** button for at least 2 seconds to activate the title scanning mode. The title in the display will blink.
- 3 Press the **◀◀ DN** or **▶▶ UP** button repeatedly until the title you want to erase is displayed.
- 4 Press and hold the **▶/||** button for at least 2 seconds to erase the title displayed.
- 5 Press the **TITLE** button to cancel the title erasing mode.

NOTES

- You cannot erase CD-TEXT.
- The operations will be cancelled if no action is taken for over 10 seconds.

SETUP Operation

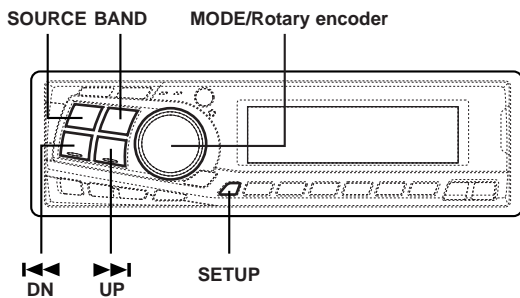

Setting the Sound Quality of the Tuner

The DVA-7996 incorporates the MAX TUNE SQ for the highest quality tuner audio. Moreover, you can choose between three settings to suit your own personal sound preferences and usage.

- 1 Press and hold the **SETUP** button for at least 3 seconds.
- 2 Press the **◀ DN** or **▶ UP** button to select "NORMAL or HI-FI or STABLE."
- 3 Press the **BAND** button to switch the TUNER mode.

→ NORMAL → HI-FI → STABLE ←

NORMAL: Standard setting
 HI-FI: Sound quality priority setting
 STABLE: Noiseless priority setting

NOTES

- The initial setting at the factory is "NORMAL."
- If you find the sound is very noisy while listening to the tuner in the HI-FI mode, we recommend you change to the NORMAL mode.

- 4 When the setting is completed, press the **SETUP** button to return to the normal mode.

NOTES

- "MP3 File Selection" and "Playing MP3 data" in the "SETUP" mode section are described in MP3 Operation on page 25.
- Audio-related setup function operations cannot be performed using the SETUP button on the remote control unit.

Changing Lighting Color

- 1 Press and hold the **SETUP** button for at least 3 seconds.
- 2 Press the **◀ DN** or **▶ UP** button to select "AMBER".
- 3 Press the **BAND** button to toggle the mode between AMBER ON (amber) and AMBER OFF (green).
- 4 Press the **SETUP** button to set the selected mode.

16-EN

Dimmer Control

Set the DIMMER control to AUTO to decrease the illumination brightness of the unit with the head lights of the vehicle ON. This mode is useful if you feel the unit's backlighting is too bright at night.

- 1 Press and hold the **SETUP** button for at least 3 seconds.
- 2 Press the **◀ DN** or **▶ UP** button to select "DIM"(DIMMER).
- 3 Press the **BAND** button to select the Dimmer mode. Each press toggles between DIM AUTO and DIM MANUAL.
- 4 Press the **SETUP** button to activate the normal mode.

Subwoofer On and Off

- 1 Press and hold the **SETUP** button for at least 3 seconds.
- 2 Press the **◀ DN** or **▶ UP** button to select "SUB-W (Subwoofer)."
- 3 Press the **BAND** button to toggle mode between SUB-W ON or LINK and SUB-W OFF.
 SUB-W ON: The subwoofer output is set to ON regardless of whether the rear DVD function (page 34) is set to ON or OFF.
 SUB-W LINK: The subwoofer output is set to ON when the rear DVD function (page 34) is set to OFF. The subwoofer output is set to OFF when the rear DVD function (page 34) is set to ON.
 SUB-W OFF: The subwoofer output is set to OFF regardless of whether the rear DVD function (page 34) is set to ON or OFF.

NOTES

- The initial setting at the factory is subwoofer ON.
- The SUB-W LINK cannot be selected when our company's external processor is connected.

- 4 Press the **SETUP** button after setting the SUB-W ON or LINK.
- 5 Press the **MODE** button repeatedly to select the SUB-W mode.

→ SUB-W → BALANCE ←
 VOLUME ← DEFEAT ← FADER ←

Press the **◀ DN** or **▶ UP** button after selecting the SUB-W mode, and the subwoofer output phase is toggled SUBW NOR (0°) or SUBW REV (180°).

- 6 Turn **Rotary encoder** until the desired sound is obtained in each mode.

NOTES

- It is not possible to adjust the subwoofer output level when "SUB-W LINK" is selected and the rear DVD function is turned on.
- Any subwoofer adjustment (level or phase) made while the rear DVD function is turned on, is stored in memory. The settings stored are recalled the next time the rear DVD function is turned on (only when our company's external processor is disconnected.).

Sound (Beep) Guide Function

This function will give audible feedback with varying tones depending upon the button pressed.

- 1 Press and hold the **SETUP** button for at least 3 seconds.
- 2 Press the **◀◀ DN** or **▶▶ UP** button to select "BEEP."
- 3 Press the **BAND** button to toggle the mode between BEEP ON and BEEP OFF.

NOTE

The initial setting at the factory is BEEP ON.

- 4 Press the **SETUP** button to set the selected mode.

Scroll Setting

This CD player can scroll the disc and track names recorded on CD-TEXT discs, as well as the text information of MP3 files, folder names, and ID3 tags.

- 1 Press and hold the **SETUP** button for at least 3 seconds.
- 2 Press the **◀◀ DN** or **▶▶ UP** button to select "SCR" (SCROLL).
- 3 Press the **BAND** button to toggle the mode between SCR AUTO and SCR MANUAL.
 - SCR AUTO: the CD text information, the text information of folder and file names, and the ID3 tags are scrolled automatically.
 - SCR MANUAL: the display is scrolled only when a disc is loaded or when a track is changed, etc.
- 4 When the setting is completed, press the **SETUP** button to return to the normal mode.

NOTES

- Initial mode is "SCR MANUAL."
- The unit scrolls CD text names, folder names, file names or ID3 tag display. The disc titles input manually (refer to page 15) cannot be scrolled.

Setting the AUX Mode (V-Link)

You can input TV/video sound by connecting an optional Ai-NET/RCA Interface cable (KCA-121B) or Versatile Link Terminal (KCA-410C) to this component.

- 1 Press and hold the **SETUP** button for at least 3 seconds.
- 2 Press the **◀◀ DN** or **▶▶ UP** button to select "AUX."
- 3 Press the **BAND** button to toggle the mode between AUX ON and AUX OFF.

NOTES

- The initial setting at the factory is AUX OFF.
- You can set the AUX mode display by pressing the **◀◀ DN** or **▶▶ UP** button after AUX ON is set. Select the AUX mode display setting, and press the **BAND** button.
- When connecting the KCA-410C, you can set two AUX mode displays.

- 4 Press the **SETUP** button to return to normal mode.
- 5 To adjust the volume, etc., first press the **SOURCE** button and select the AUX mode, then make the necessary adjustment.

NOTE

When using the Versatile Link Terminal (KCA-410C), you can connect two external inputs. To select the mode, press the **BAND** button on the unit.

Turning Mute Mode On/Off

If a device having the interrupt feature is connected, audio will be automatically muted whenever the interrupt signal is received from the device. This function can be turned ON or OFF from the head unit by following procedure below.

- 1 Press and hold the **SETUP** button for at least 3 seconds.
 - 2 Press the **◀◀ DN** or **▶▶ UP** button to select the MUTE mode.
 - 3 Press the **BAND** button to turn on or off the MUTE mode. Each press toggles between the MUTE ON and OFF modes.
- NOTE**
The initial setting at the factory is "MUTE ON."
- 4 Press the **SETUP** button again to return to normal operation.

SETUP Operation

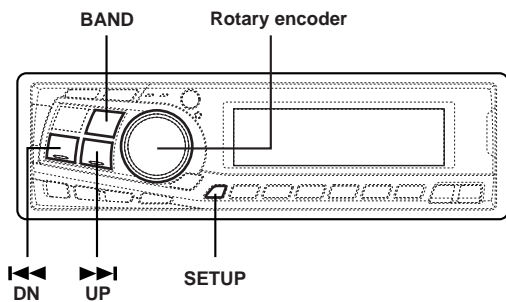

Setting the External Input Defeat Mode

Turn DEFEAT ON to bypass BASS, TREBLE and MX settings for any source using the external input.

- 1 Press and hold the **SETUP** button for at least 3 seconds.
- 2 Press the **◀ DN** or **▶ UP** button to select "INT."
- 3 Press the **BAND** button to toggle the mode between INT ON and INT OFF.
When using Initial mode, set this to ON.
When the Initial mode is not selected, set this to OFF.
- 4 Press the **SETUP** button to return to normal mode.

Demonstration

This unit has a Demonstration feature which simulates the display functions.

- 1 Press and hold the **SETUP** button for at least 3 seconds.
- 2 Press the **◀ DN** or **▶ UP** button to select the DEMO mode.
- 3 Press the **BAND** button to turn on or off the DEMO mode.
Each press toggles between DEMO ON and DEMO OFF.

If no button is pressed for 30 seconds, the DEMO mode activates.
NOTES
 - The initial setting at the factory is "DEMO OFF."
 - To quit DEMO mode, set to "DEMO OFF."
- 4 Press the **SETUP** button again to return to normal operation.

Setting the Digital Output

To connect an audio processor using the optical digital output, set to "ON" with the following procedure.

- 1 Press and hold the **SETUP** button for at least 3 seconds.
- 2 Press the **◀ DN** or **▶ UP** button to select "OPTOUT" mode.
- 3 Press the **BAND** button to set ON.

NOTE

The initial setting at the factory is "OPTOUT OFF".

- 4 Press the **SETUP** button to return to normal mode.

NOTE

Afterwards, set ACC to OFF once, then turn it ON again.
The setting of Digital Output is decided.

Optical Digital Input Selection for an External Audio Processor

Make sure "OPTOUT" is ON in "Setting the Digital Output" (page 18) before switching this setting.

- 1 Press and hold the **SETUP** button for at least 3 seconds.
- 2 Press the **◀ DN** or **▶ UP** button to select "APRC OTHER".
NOTE
When OPTOUT is ON, "APRC OTHER" is displayed.
- 3 Press the **BAND** button to toggle the mode between APRC OTHER and APRC H510.

APRC OTHER: When connecting any audio processor via the optical digital cable except the PXA-H510.
APRC H510: When connecting PXA-H510.
- 4 Press the **SETUP** button to activate the normal mode.

NOTE

Afterwards, set ACC to OFF once, then turn it ON again.
The setting of fiber digital input switch is decided.

Adjusting Display Contrast

You can adjust the audio display contrast for better visibility.

- 1 Press and hold the **SETUP** button for at least 3 seconds.
- 2 Press the **◀ DN** or **▶ UP** button to select "CONTRAST."
- 3 Turn the **Rotary encoder** to adjust the contrast of the audio display. You can adjust in a range of -6 and +6. The initial setting at the factory is "0."
- 4 Press the **SETUP** button to set the selected mode.

Radio Operation

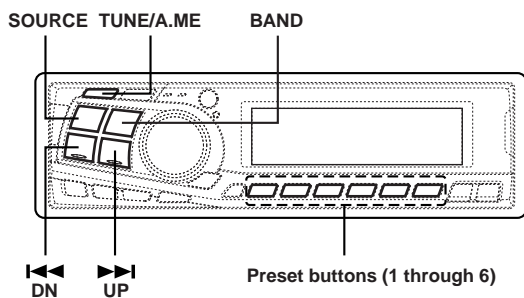

Manual Tuning

- 1 Press the **SOURCE** button until a radio frequency appears in the display.
- 2 Press the **BAND** button repeatedly until the desired radio band is displayed.

Each press changes the band:

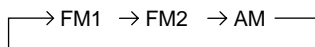

- 3 Press the **TUNE** button repeatedly until "DX SEEK" and "SEEK" disappear from the display.

NOTE

The initial mode is DX SEEK.

- 4 Press the **◀◀ DN** or **▶▶ UP** button to move downward or upward one step respectively until the desired station frequency is displayed.

NOTE

The ST indicator appears on the display when a Stereo FM station is tuned in.

Automatic Seek Tuning

- 1 Press the **SOURCE** button until a radio frequency appears in the display.
- 2 Press the **BAND** button repeatedly until the desired radio band is displayed.
- 3 Press the **TUNE** button to illuminate the DX and SEEK indicators in the display. With the DX (Distance) mode activated, both strong and weak stations will be tuned in the Auto-Seek operation. Press again to return to the local mode. The DX indicator will turn off and the SEEK indicator will remain illuminated. Now, only strong stations will be tuned.

- 4 Press the **◀◀ DN** or **▶▶ UP** button to automatically seek for a station downward or upward respectively. The unit will stop at the next station it finds. Press the same button again to seek the next station.

Manual Storing of Station Presets

- 1 Select the radio band and tune in a desired radio station you wish to store in the preset memory.
- 2 Press and hold any one of the **Preset buttons (1 through 6)** that you want to store the station on for at least 2 seconds. The selected station is stored. The display shows the band, preset No. with a triangle (\triangle) and station frequency memorized.
- 3 Repeat the procedure to store up to 5 other stations onto the same band. To use this procedure for other bands, simply select the band desired and repeat the procedure. A total of 18 stations can be stored in the preset memory (6 stations for each band; FM1, FM2 and AM).

NOTE

If you store a station in a preset memory which already has a station, the current station will be cleared and replaced with the new station.

Automatic Memory of Station Presets

- 1 Press the **SOURCE** button to select the radio mode.
- 2 Press the **BAND** button repeatedly until the desired radio band is displayed.
- 3 Press and hold the **A. ME** button for at least 2 seconds. The frequency on the display continues to change while the automatic memory is in progress. The tuner will automatically seek and store 6 strong stations in the selected band. They will be stored into buttons 1 to 6 in order of signal strength. When the automatic memory has been completed, the tuner goes to the station stored in the preset location No. 1.

NOTE

If no stations are stored, the tuner will return to the original station you were listening to before the auto memory procedure began.

Tuning to Preset Stations

- 1 Press the **SOURCE** button to select the radio mode.
- 2 Press the **BAND** button repeatedly until the desired band is displayed.
- 3 Press the station **Preset** button that has your desired radio station in memory. The display shows the band, preset number with a triangle and frequency of the station selected.

CD Player Operation

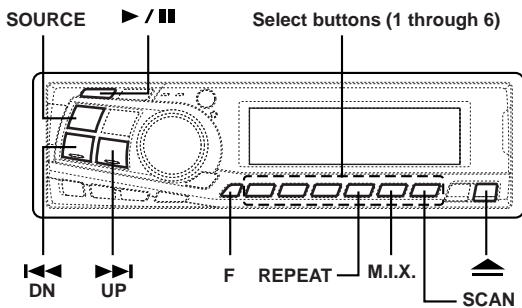

Opening and Closing the Movable display

- 1 Press the ▲ button.
The movable display will open.

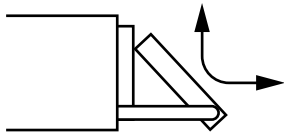

To close the movable display, press the ▲ button again.
The movable display will close.

NOTES

- Do not apply shock to the movable display when it is open as it may result in malfunction of the unit.
- The display may be dim during low temperatures and immediately after turning on the power. The brightness will return to normal as time elapses.
- The display will stop at the set angle when closing.

CAUTION

Keep hands (or any other object) away from the display while it is opening or closing to avoid damage or injury. The back of the movable display will get very warm under normal operating conditions. This is not a malfunction. Do not touch.

Playback

- 1 Press the ▲ button.
The movable display will open.

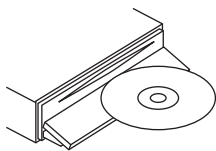

Insert a disc with the label side facing up.

- 2 Insert a disc with the label side facing up.
The disc will be pulled into the unit automatically. The movable display will close and playback will begin.
When a disc is already inserted, press the **SOURCE** button to switch to the CD (DISC) mode.

The mode will change every time the button is pressed.

→ TUNER → CD (DISC) → CD CHANGER*

* Only when the CD changer is connected)

- 3 To pause playback, press the ►/|| button.
Pressing the ►/|| button again will resume playback.

- 4 To eject the disc, press the ▲ button.

NOTES

- Do not touch the CD while it is loading or ejecting, as a malfunction may result.
- If the CD does not eject, press and hold the ▲ button for more than 3 seconds while the movable display is still open.
- Some discs require more time before playback starts. This is normal

Music Sensor (Skip)

- 1 Momentarily press the ◀◀ DN button once during CD play to return to the beginning of the current track. If you wish to access the beginning of a track further back, repeatedly press until you reach the desired track.

Press the ▶▶ UP button once to advance to the beginning of the next track. If you wish to access the beginning of a track further ahead, press repeatedly until the desired track is reached.

NOTE

The music sensor feature is functional in the play or pause mode.

Fast Forward and Backward

- 1 Press and hold the ◀◀ DN or ▶▶ UP button to quickly move backward or forward until you reach the desired section of the track.

Repeat Play

- 1 Press the **REPEAT** button to play back repeatedly the track being played.
The track will be played repeatedly.

Press the **REPEAT** button again and select OFF to deactivate the repeat play.

NOTES

- If a CD Changer is connected and the RPT ALL mode is selected, the unit repeatedly plays back all tracks on the disc selected.

→ RPT → RPT ALL → (off) —

- In case a 6-disc CD changer is connected:
In CD changer mode, press the “F” button to illuminate the “FUNC” indicator and go to step 1 within 5 seconds.
- In case a 12-disc CD changer is connected:
In changer mode, press the “F” button twice to illuminate the “FUNC” indicator and go to step 1 within 5 seconds.

M.I.X. (Random Play)

- 1 Press the **M.I.X.** button in the play or pause mode.
The tracks on the disc will be played back in a random sequence.

To cancel M.I.X. play, press the **M.I.X.** button again to turn off the M.I.X.

NOTES

- If a CD Changer equipped with the ALL M.I.X. function is connected, ALL M.I.X. will also be selectable.
In this mode, the tracks on all the CDs in the current magazine will be included in the random playback sequence.

→ M.I.X. → ALL M.I.X. → (off) —

- In case a 6-disc CD changer is connected:
In CD changer mode, press the “F” button to illuminate the “FUNC” indicator and go to step 1 within 5 seconds.
- In case a 12-disc CD changer is connected:
In CD changer mode, press the “F” button twice to illuminate the “FUNC” indicator and go to step 1 within 5 seconds.

Scanning Programs

- 1 Press the **SCAN** button to activate the Scan mode.
The first 10 seconds of each track will be played back in succession.

To stop scanning, press the **SCAN** button and deactivate the Scan mode.

NOTES

- In case a 6-disc CD changer is connected:
In CD changer mode, press the “F” button to illuminate the “FUNC” indicator and go to step 1 within 5 seconds.
- In case a 12-disc CD changer is connected:
In CD changer mode, press the “F” button twice to illuminate the “FUNC” indicator and go to step 1 within 5 seconds.

Controlling CD Changer (Optional)

An optional 6-disc or 12-disc CD Changer may be connected to the DVA-7996 if it is Ai-NET compatible. With a CD Changer connected to the Ai-NET input of the DVA-7996, the CD Changer will be controllable from the DVA-7996.

Using the KCA-400C (Multi-Changer Switching device) or the KCA-410C (Versatile Link Terminal) multiple changers can be controlled by the DVA-7996.

See the Multi-Changer Selection section on page 22 for selecting the CD Changers.

NOTES

- The controls on the DVA-7996 for CD Changer operation are operative only when a CD Changer is connected.
- The “Changer” indicator illuminates when a CD Changer is connected.
- The DVD changer (optional) is controllable from the DVA-7996 as well as the CD changer.

- 1 Press the **SOURCE** button to activate the CHANGER mode. The display shows the disc number and track number.

NOTES

- The source indicator varies depending on the connected source.
- Press the **BAND** button to switch the Disc mode in the CD/DVD/Changer mode.

- 2 Press the **Disc Select buttons (1 through 6)** corresponding to one of the discs loaded in the CD Changer. The selected disc number appears in the display and CD playback starts.

NOTES

- After selecting the desired disc, you can operate in the same way as for the DVA-7996 CD player.
For details, please see the CD Operation section.
- If the “FUNC” indicator is illuminated the Disc Select buttons become nonfunctional.

When a 12-disc CD Changer is connected:

To select discs numbered from 1 to 6, the procedure is the same as for the 6-disc CD Changer. To select discs numbered from 7 to 12, first press the “F” button. This changes the “D” indicator to “d.” Then press the desired Preset button. With the “F” button activated, the Preset buttons 1 to 6 will represent discs 7 to 12 respectively.

CD Player Operation

SOURCE BAND

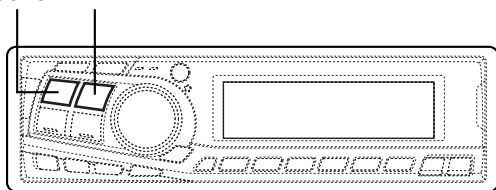

Multi-Changer Selection

Alpine's Ai-NET system will support up to 6 CD Changers. When operating two or more changers, the KCA-400C (Multi-Changer Switching device) must be used. If you use 1 Switching device, you can connect up to 4 CD Changers. If you use 2 Switching devices, you can connect up to 6 CD Changers. When using KCA-410C (Versatile Link Terminal), you can connect two changers and two external outputs (AUX).

- 1 Press the **SOURCE** button on the DVA-7996 to activate the CD Changer mode.

Alternatively, press the **SOURCE** button on the Remote Control (RUE-4190) to activate the CD Changer mode.

- 2 Press the **BAND** button on the DVA-7996 or the RUE-4190 to activate the CD Changer Selection mode.

- 3 The CD Changer Selection mode remains active for 8 seconds after step 2 is performed. Press the **BAND** button until the desired CD Changer indicator appears on the display.

NOTE

If the selected CD Changer is not connected, the display will show "NO CHGR."

Alternatively press the **BAND** button on the Remote Control until the desired changer indicator appears on the display.

- 4 To operate the selected changer, see "CD Player Operation" section.

NOTE

For further details about the external input (AUX) when using KCA-410C, see "Setting the AUX Mode (V-Link)" on page 17.

MP3 Operation

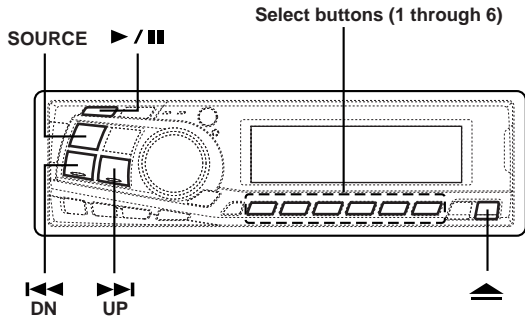

Playing MP3 Files

The DVA-7996 will play back MP3 files stored on CD-ROMs, CD-Rs, and CD-RWs. The format used must be compliant with ISO 9660 level 1 or level 2. For further information about playing or storing MP3 files, refer to pages 25 and 26 before using the unit.

- 1 Press the ▲ button.
The movable display will open.

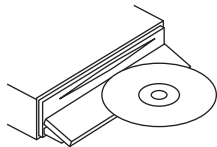

Insert a disc containing an MP3 file with the label side facing up.

- 2 The disc will be pulled into the unit automatically. The movable display will close and playback will begin. When a disc is already inserted, press the **SOURCE** button to switch to the CD (DISC) mode.

The mode will change every time the button is pressed.

→ TUNER → CD (DISC) → CD CHANGER*

* Only when the CD changer is connected)

- 3 To pause playback, press the ►/|| button.
Pressing the ►/|| button again will resume playback.
- 4 To eject the disc, press the ▲ button.

NOTES

- The unit can play discs containing both audio data and MP3 data.
- For MP3 discs, some time may be required until playback starts.
- If the CD does not eject, press and hold the ▲ button for more than 3 seconds while the movable display is still open.
- The track display for CD audio data playback is the track numbers recorded on the disc.
- The MP3 indicator is lit during MP3 playback.

Playing MP3 Files with the CD Changer (Optional)

If you connect a changer compatible with MP3, you can play CD-ROMs, CD-Rs, and CD-RWs containing MP3 files on the DVA-7996.

- 1 Press the **SOURCE** button to switch to the MP3 Changer mode.
Folder Number, File Number and Elapsed Time are displayed.
- 2 Press the Disc **Select buttons (1 through 6)** corresponding to one of the discs loaded in the CD Changer.
- 3 To pause playback, press the ►/|| button.
Pressing the ►/|| button again will resume playback.

NOTE

The unit can play discs containing both audio data and MP3 data.

Music Sensor (Skip)

- 1 Momentarily press the ◀◀ DN button once during CD play to return to the beginning of the current file. If you wish to access the beginning of a file further back, repeatedly press until you reach the desired file.

Press the ▶▶ UP button once to advance to the beginning of the next file. If you wish to access the beginning of a file further ahead, press repeatedly until the desired file is reached.

NOTE

The music sensor feature is functional in the play or pause mode.

Fast Forward and Backward

- 1 Press and hold the ◀◀ DN or ▶▶ UP button to quickly move backward or forward until you reach the desired section of the file.

MP3 Operation

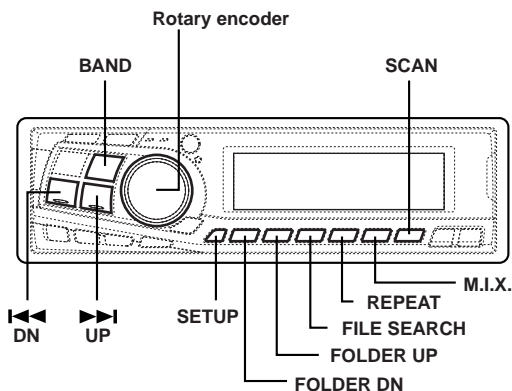

Selecting Folders

- 1 Press the **FOLDER DN** or **FOLDER UP** button to select the folder.

NOTE

If a CD changer applicable to MP3 is connected:
In CD changer mode, press the "F" button to illuminate the "FUNC" indicator and go to step 1 within 5 seconds.

File Search

You can locate all the files on a disc and play them.

- 1 Press the **FILE SEARCH** button during playback. The unit switches to File Search mode.
- 2 Turn the **Rotary encoder** to select the desired file.
- 3 Press the **Rotary encoder** to execute the setting. The selected file starts to play.

NOTES

- During search, press the **FILE SEARCH** button to cancel the File Search mode.
- If a CD changer applicable to MP3 is connected:
In CD changer mode, press the "F" button to illuminate the "FUNC" indicator and go to step 1 within 5 seconds.

Repeat Play

- 1 Press the **REPEAT** button to play back repeatedly the file being played.

The file will be played repeatedly.

Press the **REPEAT** button again and select OFF to deactivate the repeat play.

NOTES

- If a CD changer applicable to MP3 is connected and the RPT ALL mode is selected, the unit repeatedly plays back all files on the selected disc.

→ RPT → RPT ALL → (off) →

- When you select "FOLDER" and set to RPT ALL in the "Setting the Range of MP3 File Selection" section on page 25, the Files will be repeatedly played back.
- If a CD changer applicable to MP3 is connected:
In CD changer mode, press the "F" button to illuminate the "FUNC" indicator and go to step 1 within 5 seconds.

M.I.X. (Random Play)

- 1 Press the **M.I.X.** button in the play or pause mode. The files on the disc will be played back in a random sequence.

To cancel M.I.X. play, press the **M.I.X.** button again to turn off the M.I.X.

NOTES

- When you select "FOLDER" and set to M.I.X. in the "Setting the Range of MP3 File Selection" section on page 25, the Files in the Folder are played back in random sequence. After all the files have been played back, play does not shift to the next Folder.
- In case an MP3 compatible CD changer is connected:
In CD changer mode, press the "F" button to illuminate the "FUNC" indicator and go to step 1 within 5 seconds.

Scanning Programs

- 1 Press the **SCAN** button to activate the Scan mode. The first 10 seconds of each file will be played back in succession.

To stop scanning, press the **SCAN** button and deactivate the Scan mode.

NOTES

- When you select "FOLDER" in the "Setting the Range of MP3 File Selection" section on page 25, the first 10 seconds of each File in the Folder will be played back.
- If a CD changer applicable to MP3 is connected:
In CD changer mode, press the "F" button to illuminate the "FUNC" indicator and go to step 1 within 5 seconds.

Setting the Range of MP3 File Selection

You can set the range of MP3 file selection to "entire disc contents" or "folder contents only."

- 1 Press and hold the **SETUP** button for at least 3 seconds.
 - 2 Press the **◀◀ DN** or **▶▶ UP** button to select DISC/ FOLDER (file selection range).
 - 3 Press the **BAND** button to toggle the mode between DISC ALL and FOLDER.
 - DISC ALL : plays all the files on one disc
 - FOLDER : plays files in the selected folder only.
- NOTES**
- The initial setting at the factory is DISC ALL.
 - For the MP3 CD Changer, the range of MP3 file selection applies to REPEAT, M.I.X. and SCAN modes only. The unit plays all files on a disc even if the MP3 Range selection is set to "folder contents only."
 - Perform this setting before loading the disc. If the disc is already loaded, perform either of the following to decide the setting.
 - Turn OFF the main unit
 - Disc eject
 - Switch source
- 4 Press the **SETUP** button to set the selected mode.

Playing MP3 Data

The unit can be set to play only the audio data ("Mix Disc CD") or only the MP3 files ("Mix Disc MP3") on discs containing both audio data and MP3 data (when using discs containing both audio data and MP3 data).

- 1 Press and hold the **SETUP** button for at least 3 seconds.
- 2 Press the **◀◀ DN** or **▶▶ UP** button to select "Mix Disc CD/MP3."
- 3 Press the **BAND** button to toggle the mode between MixDisc CD and MixDisc MP3.
 - MixDisc CD: The unit can be set to play only the audio data on discs containing both audio data and MP3 data.
 - MixDisc MP3: Only the MP3 files on discs containing both audio data and MP3 data.
- 4 Press the **SETUP** button to return to normal mode.

NOTE

Perform this setting before loading the disc. If the disc is already loaded, perform either of the following to decide the setting.

- Turn OFF the main unit
- Disc eject
- Switch source

About MP3

CAUTION

Except for personal enjoyment, duplicating audio data (including MP3 data) or distributing, transferring, or copying it, whether for free or for a fee, without the permission of the copyright holder is strictly prohibited by the Copyright Act and by international treaty.

• What is MP3?

MP3, whose official name is "MPEG Audio Layer 3", is a compression standard prescribed by the ISO, the International Standardization Organization and MPEG which is a joint activity institution of the IEC.

MP3 files contain compressed audio data. MP3 encoding is capable of compressing the audio data at extremely high ratios shrinking music files by as much as one-tenth their original size. This is achieved while still maintaining near CD quality. The MP3 format realizes such high compression ratios by eliminating the sounds that are either inaudible to the human ear or masked by other sounds.

• Method for creating MP3 files

The software used to create MP3 files is widely sold or free from various sources. For details on creating MP3 files, refer to the user's manual for that software. The MP3 files that can be played back by this device have the file extension "mp3". Files with no extension can not be played back.

• Supported playback sampling rates and bit rates

Sampling rates: 16 kHz - 48 kHz, bit rates: 32 - 320 kbps
Note that for sampling rates such as 22.05 kHz, this device's frame display (Page 14) may not display correctly.

• ID3 tags

This device supports ID3 tag v1.
If ID3 tag data is in an MP3 file, this device can display the title (track title), artist name, and album name ID3 tag data.

This device can only display single-byte alphanumeric characters and the underscore. For non-supported characters, "NO SUPPORT" is displayed.

• Producing MP3 discs

MP3 files are prepared, then written to a CD-R or CD-RW using CD-R writing software. A disc can hold up to 255 files/folders (including Root Folders).

• Media supported

The media that this device can play back are CD-ROMs, CD-Rs, and CD-RWs.

Continued

MP3 Operation

• Corresponding File Systems

This device supports discs formatted with ISO9660 Level 1 or Level 2.

Under the ISO9660 standard, there are some restrictions to remember.

The maximum nested folder depth is 8 (including the root directory). File/folder names are limited to 31 characters (including the extension).

Valid characters for folder/file names are letters A-Z (all caps), numbers 0-9, and '_' (underscore).

This device also can play back discs in Joliet, and other standards that conform to ISO9660. However, sometimes the file names, folder names, etc. are not displayed correctly.

• Formats supported

This device supports CD-ROM XA, Mixed Mode CD, Enhanced CD (CD-Extra) and Multi-Session.

This device can not correctly play back discs recorded with Track At Once or packet writing.

• Order of tracks

The unit plays the files in the order that the writing software writes them. Therefore, the playing order may not be the same as the order you input. The playback order of the folders and files is as follows.

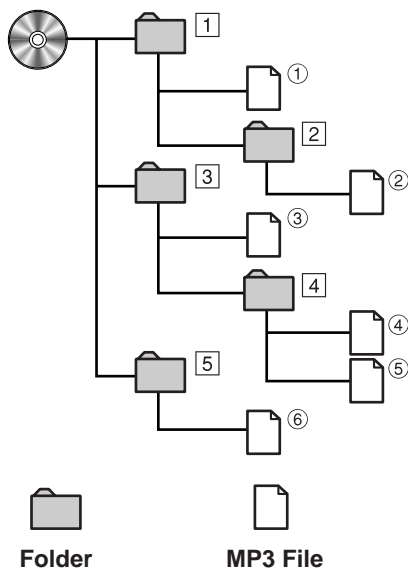

Terminology

Bit rate

This is the "sound" compression rate specified for encoding. The higher the bit rate, the higher the sound quality, but also the larger the files.

Sampling rate

This value shows how many times per second the data is sampled (recorded). For example, music CDs use a sampling rate of 44.1 kHz, so the sound level is sampled (recorded) 44,100 times per second. The higher the sampling rate, the higher the sound quality, but also the larger the volume of data.

Encoding

Converting music CDs, WAVE (AIFF) files, and other sound files into the specified audio compression format.

ID3 tag

Song information such as track titles, artist names, album names, etc., written into MP3 files.

XM Radio Operation

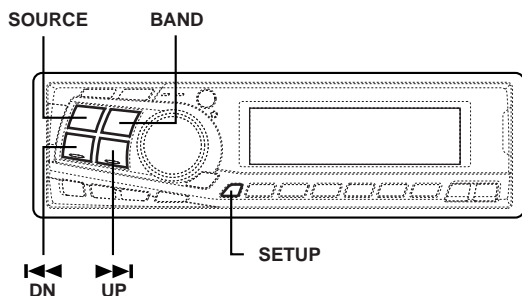

Receiving XM Channels with the XM Receiver (Optional)

XM Satellite Radio* is the next generation of audio entertainment, with up to 100 brand-new digital channels. For a small monthly fee, subscribers can hear crystal-clear music, sports, news and talk, coast-to-coast via satellite. For more information, visit XM's website at www.xmradio.com or call 1-800-852-9696.

An optional XM Satellite Radio Receiver (TUA-T020XM) may be connected to the DVA-7996. With an XM Receiver connected to the Ai-NET input of the DVA-7996, the XM Receiver will be controllable from the DVA-7996.

* XM and its corresponding logos are trademarks of XM Satellite Radio Inc.

NOTES

- The controls on the DVA-7996 for XM Receiver operation are operative only when an XM Receiver is connected.
- The XM1 or XM2 band illuminates when in XM mode.

1 Press the **SOURCE** button to select RADIO Mode.

2 Press the **BAND** button to select XM1 or XM2.

Each press changes the band:

→ FM1 → FM2 → XM1 → XM2 → AM →

3 Press the **◀ DN** or **▶ UP** button to select the desired channel. Holding the **◀ DN** or **▶ UP** buttons will change channels continuously.

Checking the XM Radio ID Number

You need to provide XM with the unique XM Radio ID number for your XM Radio Receiver in order to subscribe to XM's programming.

This number is an 8 character alphanumeric number that is printed on a label directly on the XM Receiver. It can also be displayed on the screen of the DVA-7996 in the following way.

- 1** While receiving XM1/XM2, press the **◀ DN** or **▶ UP** button to select channel "0."
- 2** The unit alternately displays "RADIO ID" for 2 seconds, then the ID number for 10 seconds.
- 3** To cancel the ID number display, set the channel to other than "0."



Tips There is another way to display your ID number.

1. Press and hold the **SETUP** button for at least 3 seconds.
2. Press the **◀ DN** or **▶ UP** button repeatedly to select "ID."
3. Press the **BAND** button to display your ID number.
4. After checking your ID number, press the **SETUP** button to return to the normal display.

NOTES

- You cannot use "O," "S," "I," or "F" for the ID Number.
- You can check your ID number printed on the label on the package of your XM Satellite Radio Receiver (TUA-T020XM).

XM Radio Operation

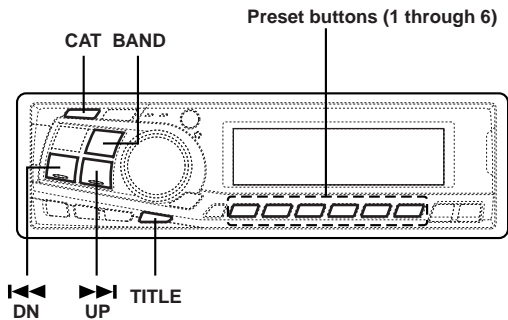

Storing XM Channel Presets

- 1 Press the **BAND** button to select the desired band (XM1 or XM2) you want to store.
- 2 After tuning in the desired channel, press and hold any one of the **Preset buttons (1 through 6)** that you want to store the station on for at least 2 seconds. The selected station is stored.
- 3 Repeat the procedure to store up to 5 other channels onto the same band.
To use this procedure for other bands, simply select the band desired and repeat the procedure.
A total of 12 channels can be stored in the preset memory (6 channels for each band; XM1 and XM2).

NOTE

If you store a channel in a preset memory which already has a station, the current channel will be cleared and replaced with the new one.

Receiving Stored XM Channels

- 1 Press the **BAND** button to select the desired band (XM1 or XM2).

→ FM1 → FM2 → XM1 → XM2 → AM
- 2 Press the channel **Preset** button that has your desired satellite channel in memory.

Category Search

Category Search functionality allows you to search for a specific channel by the category of programming it offers, or to surf within a given category.

- 1 In XM mode, press the **CAT** button to display the category of the channel that is currently selected for 13 seconds.
- 2 While the category is displayed, press the **◀ DN** or **▶ UP** button to select a different category (or leave it to stay with the same category.)
- 3 Within 13 seconds of selecting the category, press the **CAT** button again to select the next channel within that category. Repeatedly press the **CAT** button within 13 seconds to select additional channels within that category.

When tuned in, the category is displayed for 13 seconds, then the display returns to normal mode.

NOTE

If you cannot find your desired category, the display shows "-----" for 2 seconds automatically.

Changing the Display

Text information, such as the channel name, artist name/feature, and song/program title, is available with each XM channel. The unit can display this text information as explained below.

- 1 In XM mode, press the **TITLE** button.

Each time you press this button, the display changes as shown below.

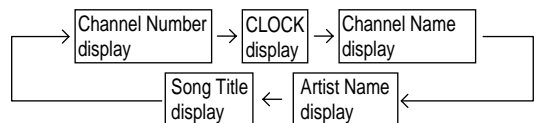

NOTES

- When the "Scroll Setting" (refer to page 17) is set to "SCR AUTO", the display scrolls.
When the Scroll Setting is set to "SCR MANUAL", the display scrolls only when you operate the unit (POWER ON, BAND, etc., are displayed.)
Press and hold the **TITLE** button for more than 3 seconds to scroll the display again.
- "Channel Number" and "Clock" displays do not scroll.
- Depending on the model, the display may differ from the one shown above.

DVD/Video CD Operation

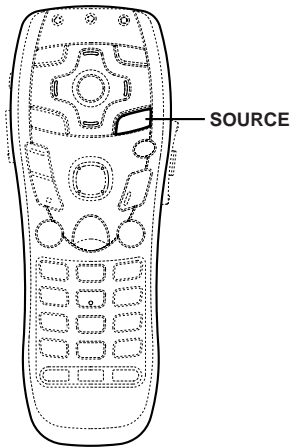

Playing DVD/Video CD

- ⚠ Caution**
- Not all functions will operate for every DVD. See the individual DVD's instructions for details on the features supported.
 - Fingerprints on a disc may adversely affect playback. If a problem occurs, remove the disc and check for fingerprints on the playback side. Clean the disc if necessary.
 - When using the remote control, be careful to press one button at a time. Pressing multiple buttons at the same time may cause erroneous operation.
 - If you switch the power or Ignition Key OFF or change sources during playback, playback will continue where you left off when you resume playback.
 - If you try to perform an invalid operation (based on the type of disc being played), the following mark is displayed on the monitor screen:

- DVD and video CD operations can be performed from both the remote control unit and the main unit (except for some operations). This section mainly describes operations from the remote control unit. For instructions on operating using the buttons on the main unit, see page 42.
- A separately sold monitor is required to view DVDs and video CDs.
- **Play Position Memory Function:** Even if you turn power off or switch the Ignition Key to OFF during playback or change the source, playback will continue from the point where playback stopped when the power is turned ON again.

- 1 Press the button on the main unit. The movable display will open.

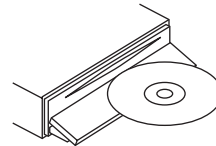

Insert a disc with the label side facing up.

- 2 Insert a disc with the label side facing up. The disc will be pulled into the unit automatically. The movable display will close and playback will begin. When a disc is already inserted, press the **SOURCE** button to switch to the disc mode.

- 3 To eject the disc, press the button on the main unit.

NOTES

- If the disc does not eject, press and hold the button again for more than 3 seconds with the movable display open.
- The reverse side of a double-sided DVD will not be played automatically. Remove the disc, turn it over, and reinsert it.
- DO NOT insert discs containing maps for the navigation system. Doing so could result in damage.
- "DISC ERROR" appears on the monitor display if a non-compatible disc is loaded, if the disc is loaded upside-down or if the disc is scratched or dirty. Press the button on the main unit to open the display and remove the disc.



- **When using the remote control unit**
To operate a DVD or video CD, set the selector switch on the rear of the remote control unit to the "AUDIO" side.

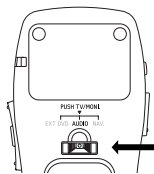

• Reading this manual

These indicate the discs for which the function can be used.

Stopping playback (PRE-STOP)

Press the stop button during playback to stop playback. That position is stored in the memory.

- 1 Press the button once during playback. "PRE-STOP" is displayed.

...DVDs
 ...Video CDs

Continued

29-EN

DVD/Video CD Operation

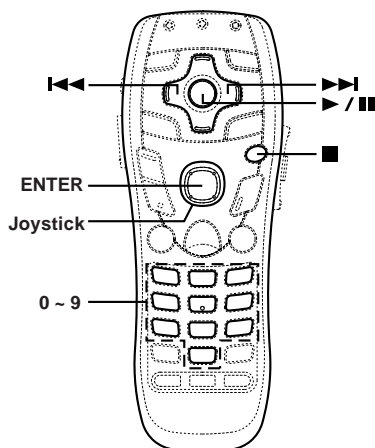

• If a menu screen appears



On DVDs and video CDs with playback control (PBC), menu screens may appear automatically. If this happens, perform the operation described below to start playback.

NOTE

For many discs, the menu screen can also be displayed by pressing the **MENU** or **TITLE** button (for at least 2 seconds).

DVD menu

Use the **Joystick** to select the desired item, then press the **ENTER** button.

NOTE

For some discs it is possible to select items directly from the menu screen using the number keys ("0" to "9").

Video CD menu

Use the number keys ("**0**" to "**9**") to select the desired number.

NOTE

The menu screen does not appear when the PBC function is turned off. If this is the case, press the **MENU** button to turn on the PBC function.

Stopping playback (PRE-STOP)



Press the stop button during playback to stop playback. That position is stored in the memory.

1 Press the **■** button once during playback. "PRE-STOP" is displayed.

2 Press the **▶/||** button in the PRE-STOP mode. Playback starts from the position at which it was stopped.

NOTE

For some discs, the position at which playback was stopped may not be accurate.

Stopping playback



1 Press the **■** button twice during playback. "STOP" is displayed, and playback stops.

NOTES

- Playback stops even when the **■** button is pressed for more than 2 seconds.
- Playback starts from the beginning when **▶/||** button is pressed while playback is stopped.

Fast-forwarding/ fast-reversing



1 During playback, press and hold the **◀◀** (fast-reverse) or **▶▶** (fast-forward) button. When pressed for more than 1 second, the disc is forwarded/reversed at double speed. When held in 5 more seconds, the disc is forwarded/reversed at 8 times the normal speed.

2 Release the **◀◀** or **▶▶** button to return to normal playback.

NOTES

- No sound or subtitles are played during fast-forwarding/fast-reversing.
- For DVDs and video CDs with playback control (PBC), the menu screen may reappear during fast-forwarding/fast-reversing.

Finding the beginnings of chapters or tracks



1 During playback, press the **◀◀** or **▶▶** button. The chapter/track switches each time the button is pressed, and playback of the selected chapter/track starts.

- ▶▶**: Press this to start playback from the beginning of the following chapter or track.
- ◀◀**: Press this to start playback from the beginning of the current chapter or track.

NOTE

Some DVDs do not have chapters.

Supplementary explanation

"**Chapters**" are divisions of movies or musical selections on DVDs.

"**Tracks**" are divisions of movies or musical selections on video and music CDs.

Playing still frames (pausing)

DVD
Video CD

- 1 During playback, press the ►|| button once.
- 2 Press the ►|| button to resume playback.

NOTES

- No sound is played during the still frame mode.
- The image or sound may stop temporarily when playback starts from the pause mode. This is not a malfunction.

Frame-by-frame playback

DVD
Video CD

- 1 In the pause mode, press the ►► button. The picture advances by one frame each time the button is pressed.
- 2 Press the ►|| button to resume normal playback.

NOTE

No sound is played during frame-by-frame playback.

Slow motion playback

DVD
Video CD

- 1 When ►► is pressed and held in while in the pause mode, the 1/8th speed slow motion playback mode is set. When held in for 5 more seconds, the slow motion speed switches to 1/2 the normal speed.
- 2 Release the ►► button to pause, and press the ►|| button to playback.

NOTES

- No sound is played during slow motion playback.
- Back slow motion playback is not available.
- 1/2, 1/8 are approximate speeds. The actual speed differs from disc to disc.

Chapter/track/title repeat playback

DVD
Video CD

Use this function to play the disc's titles, chapters or tracks repeatedly.

- 1 During playback, press the **REPEAT** button on the main unit. The repeat mode switches each time the button is pressed.

DVD

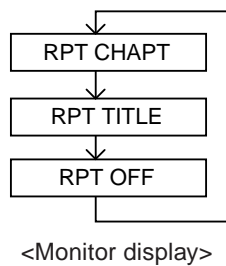

The chapter is played repeatedly.
The title is played repeatedly.
The mode returns to normal playback. (factory default)

<Monitor display>

Video CD

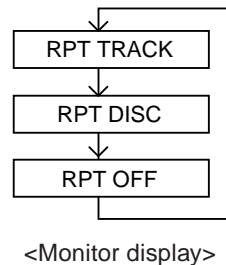

The track is played repeatedly.
The entire disc is played repeatedly. (factory default)

<Monitor display>

NOTES

- The track/disc repeat modes cannot be used on video CDs with playback control (PBC). Press the MENU button to turn the PBC function off.
- For some discs it is not possible to switch the repeat mode.

Searching by title number

DVD

Use this function to easily find positions on the DVD using the DVD's title.

- 1 When the playback stops, input the number of the title you want to play using the number keys ("0" to "9").

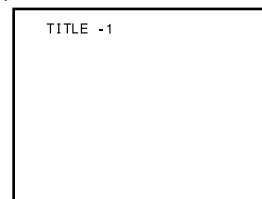

(The monitor display when title number 1 is input.)

NOTES

- This function cannot be used on discs on which no title numbers are recorded.
- Press the DEL. button to delete the last digit in the title number. Press and hold the DEL. button for at least 2 seconds to clear all title numbers.
- Press the RTN button to cancel the title search mode and resume normal playback.
- The playback starts automatically for two digit title numbers even if the ENTER button in procedure 2 is not pressed.
- Playback starts from the beginning of the chapter/track number in the state of PRE-STOP.

- 2 Press the **ENTER** button. Playback starts from the selected title number.

DVD/Video CD Operation

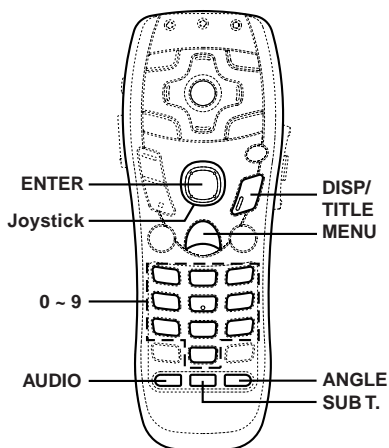

Searching directly by chapter or track number



Use this function to easily move to the beginnings of the chapters or tracks on the disc.

- 1 Except during the stop mode, input the number of the chapter or track you want to play using the number keys (“0” to “9”).

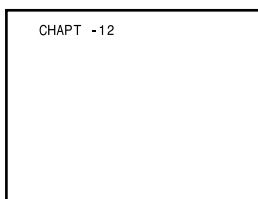

(The monitor display when chapter 12 is input.)

- 2 Press the **ENTER** button.

Playback starts from the selected chapter or track.

NOTES

- This function cannot be used on discs on which no chapter numbers are recorded.
- If the chapter number is a 3-digit number, playback starts automatically even if the **ENTER** button is not pressed at step 2.
- Press the **DEL.** button to delete the last digit in the chapter/track number. Press and hold the **DEL.** button for at least 2 seconds to clear “Chapter” and “Track” numbers.
- Press the **RTN** button to cancel the chapter/track search mode and resume normal playback.
- With video discs containing playback control (PBC), the “searching directly by track number” function is not available while PBC is ON. Press the **MENU** button to turn the PBC function off.
- If the chapter/track number is known, you can search directly using the number keys (“0” to “9”) during playback mode, **PRE-STOP** mode, etc.

Switching the angle



On DVDs in which scenes have been filmed from multiple angles, the angle can be switched during playback.

- 1 During playback, press and hold the **ANGLE** button.
The angle switches between the angles recorded on the disc each time the button is pressed.

NOTES

- Some time may be required for the angle to change.
- Depending on the disc, the angle may switch in one of two ways.
 - Seamless: The angle switches smoothly.
 - Non-seamless: When the angle is switched, a still picture is displayed first, after which the angle switches.
- This operation cannot be performed using the **ANGLE▲▼** button on the main unit.

Switching the audio tracks



DVDs can have up to 8 different audio tracks. These alternate tracks can be switched during playback.

- 1 During playback, press and hold the **AUDIO** button.
The sound switches between the alternate audio tracks recorded on the disc each time the button is pressed.

NOTES

- The alternate track selected becomes the default setting every time the power is turned on or the disc is replaced. If the disc does not include that track, the disc’s default language is selected instead.
- Not all discs will allow changing the alternate audio tracks during playback. In these cases, select audio tracks from the **DVDs** menu.
- There may be a delay before the selected alternate track begins to play.

• Video CDs with multiplex audio

- 1 During playback, press and hold the **AUDIO** button.
The left and right channels will be output as shown in the figure below, each time the button is pressed.

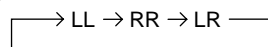

Switching the subtitles (subtitle language)

(DVD)

With DVDs on which multiple subtitle languages are recorded, the subtitle language can be switched during playback; moreover, subtitles can be hidden.

- 1 During playback, press and hold the **SUB T.** button.
The subtitle switches between the languages recorded on the disc each time the button is pressed; moreover, the subtitle is turned OFF.

NOTES

- There may be a delay before the selected subtitle appears.
- Not all discs will allow changing the subtitles during playback. In these cases, select subtitles from the DVDs menu.
- The subtitle language selected becomes the default setting every time the power is turned on or the disc is replaced. If the disc does not include that language, the disc's default language is selected instead.
- For some discs, the subtitles will be displayed even when this is set to off.



- **Switching from the disc menu**
Tips For some discs, the audio language, angle and subtitles can be switched from the disc menu.

- 1 Press the **MENU** or **TITLE** button (for at least 2 seconds), select the item, then press the **ENTER** button.
- 2 Use the **Joystick** to select the language or angle, then press the **ENTER** button.
(For some discs, they can be selected using the number keys ("0" to "9") while the language or the angle menu is displayed.)

Displaying the disc status and changing the settings

(DVD)

Use the procedure described below to display the status (title number, chapter number, etc.) of the currently playing DVD on the monitor screen. Moreover, the settings can be changed.

- 1 During playback, press the **DISP** button.
The playback status is displayed.

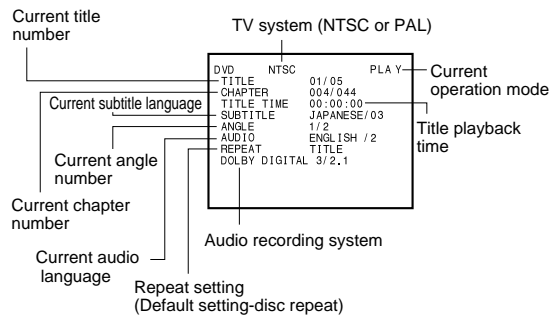

- 2 To change the setting ...
Move the **Joystick** up or down to select the item you want to set, then move the **Joystick** left or right to change the setting.
 - 3 Press the **ENTER** button. The setting is entered.
- NOTE**
For some discs, the setting may be entered after the operation in step 2.
- 4 Press the **DISP** button once more to turn the display off.

NOTES

- For some discs it may not be possible to change the setting.
- The "TITLE TIME" setting cannot be changed.
- This operation cannot be performed using the **DISP** button on the main unit.

Displaying the disc status and changing the settings

(Video CD)

Use the procedure described below to obtain an on-screen display of the status (track number, etc.) of the currently playing video CD or music CD. Additionally, the settings can also be changed from this display.

- 1 During playback, press the **DISP** button.
The playback status is displayed.

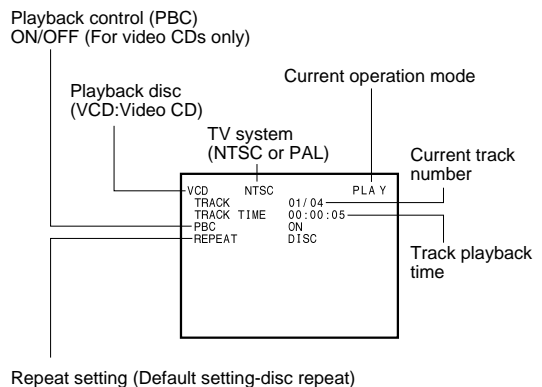

Continued

DVD/Video CD Operation

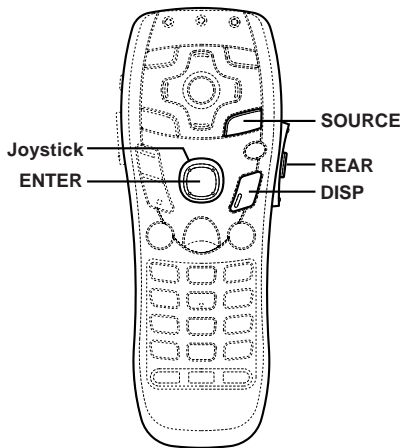

2 To change the setting ...
Move the **Joystick** up or down to select the item you want to set, then move the **Joystick** left or right to change the setting.

3 Press the **ENTER** button. The setting is entered.

NOTES

- When PBC is turned on, the setting cannot be changed. Press the MENU button to turn PBC off.
- This operation cannot be performed using the DISP button on the main unit.

4 Press the **DISP** button once more to turn the display off.

Rear DVD function

When the rear DVD function is set to "ON", it is possible to play different sources in the front and rear seats of the vehicle. For example, the riders in the front seat can listen to the radio or another audio source while a rider in the rear views a DVD using a separately sold rear monitor and headphones.

1 To view from the rear monitor, load the DVD or video CD into the main unit.
2 Press the **REAR** button to switch the rear DVD function on and off.
When turned on, the REAR DVD indicator on the audio display lights.

When turned on:

Simultaneous playback/independent operation for the front and rear seats is enabled.

The front audio source operations are performed using the DVA-7996's front panel switches. The DVD playback operations for the rear monitor are performed with the remote control unit.

3 Press the **SOURCE** button to select the audio source to be played in the front.

NOTES

- This function cannot be set if no DVD or video CD is loaded.
- When the rear DVD function setting is turned on and the remote control sensor selector is set to "REM.REAR", some remote control operations (POWER ON/OFF, VOLUME UP/DN, MUTE, SOURCE, ANGLE UP/DN, A. PROC, BAND) cannot be performed.
- The volume of any add-on displays (rear monitor, etc.) cannot be adjusted from the DVA-7996. Adjust the volume on the display itself. In addition, its sound cannot be muted.
- The function for external interruption of the sound of the rear monitor (from the navigation system, for example) cannot be used when the rear DVD function setting is turned on.
- When the fader is adjusted while the rear DVD function setting is turned on, that adjustment value is stored in the memory. When the rear DVD function is turned on again, the value stored in the memory is set (only when our company's external processor is disconnected.).
- If you are listening to the AM radio (near 1540 kHz or 1640 kHz) while the rear DVD function is set to ON, noises may be heard from the radio, but this is not a malfunction.

Remote control sensor selector

Use this selector to select whether to use the DVA-7996's remote control sensor or the remote control sensor on the extension unit.

1 Press and hold the **REAR** button for at least 2 seconds to switch the remote control sensor.

REM.FRONT (to use the DVA-7996's remote control sensor)



REM.REAR (to use a separately sold remote control sensor unit or the monitor's remote control sensor)

DVD Default Settings (SETUP)

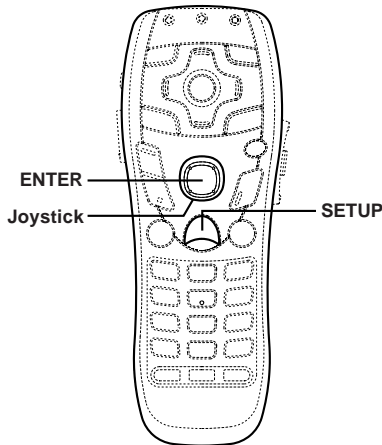

- Use the **Joystick** to make the selection, then press the **ENTER** button.

AUDIO

Set the audio language produced from the speakers.

SUBTITLE

Set the language of the subtitles displayed on the screen.

MENU LANGUAGE

Set the language used for the menus (title menu, etc.).

Changing the language settings

The audio language, subtitle language and menu language can be set according to your preferences. Once set, this becomes the default language. This function is convenient when you always want to listen in English. (Not all discs allow changing the default language. If not, the default language is set from the factory.)

NOTES

- When the settings are changed, the old settings are overwritten. Make a note of the current settings before making changes. The settings are not cleared even when the vehicle's battery is disconnected.
- To temporarily change the language of the current disc, either do so from the DVD menu or using the operation described in the section "Switching the audio tracks" (page 32).
- If you change the language setting when the disc is inside, the setting is decided with either of the following operation.
 - Disc eject
 - Turn OFF the main unit
 - Switch source
 - Turn OFF the ignition

- In the stop mode, press and hold the **SETUP** button for at least 2 seconds. The setup menu appears on the monitor screen.

SETUP	
LANGUAGES	
TV SCREEN	16:9
COUNTRY CODE	8583
RATING LEVEL	OFF
DOWN SAMPLING	ON
DIGITAL OUT	AUTO

NOTE

This operation cannot be performed in the PRE-STOP mode. When the disc is being played, press the **■** button twice to set the stop mode.

- Use the **Joystick** to select "LANGUAGES", then press the **ENTER** button.

LANGUAGES	
AUDIO	JAPANESE
SUBTITLE	AUTO
MENU	ENGLISH

- Use the **Joystick** to select the desired language, then press the **ENTER** button.

The setup screen for the selected language is displayed.

AUDIO	
ENGLISH	HUNGARIAN
JAPANESE	ITALIAN
GERMAN	YIDDISH
SPANISH	PORTUGUESE
FRENCH	RUSSIAN
HINDI	CHINESE
ORIGINAL	OTHERS 0000

AUDIO
(audio languages)

SUBTITLE	
ENGLISH	HUNGARIAN
JAPANESE	ITALIAN
GERMAN	YIDDISH
SPANISH	PORTUGUESE
FRENCH	RUSSIAN
HINDI	CHINESE
AUTO	OTHERS 0000

SUBTITLE
(subtitle languages)

MENU LANGUAGE	
ENGLISH	HUNGARIAN
JAPANESE	ITALIAN
GERMAN	YIDDISH
SPANISH	PORTUGUESE
FRENCH	RUSSIAN
HINDI	CHINESE
AUTO	OTHERS 0000

MENU LANGUAGE
(menu languages)

ORIGINAL

The disc is played with the audio language set as the priority language for the disc. (AUDIO only)

Continued

DVD Default Settings (SETUP)

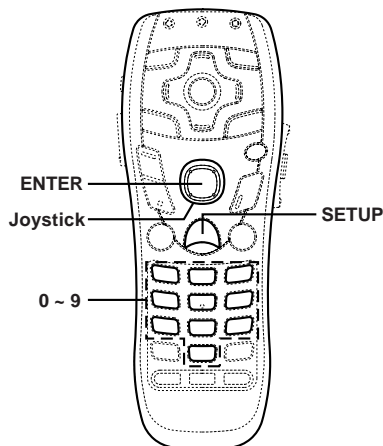

AUTO

The disc is played with the subtitle language set as the priority language for the disc. (SUBTITLE/MENU LANGUAGE only)

OTHERS

Set this to play the disc with a language other than one of the languages displayed. Use the keys "0" to "9" to input the 4-digit language code, then press the **ENTER** button. For the language codes, refer to "List of language codes" (page 48).

NOTES

- If the disc does not include the selected language, the disc's default language is set.
- Languages set upon shipment from the factory:
Audio language : ORIGINAL
Subtitle language : AUTO
Menu language : AUTO
- Press the RTN button to return to the previous screen.

- 5 Press and hold the **SETUP** button for at least 2 seconds.

The settings are stored and the set up mode is canceled.

NOTE

If you change the language setting when the disc is inside, the setting is decided with either of the following operation.

- Disc eject
- Turn OFF the main unit
- Switch source
- Turn OFF the ignition

Changing the TV screen settings

Use the procedure described below to set the output screen according to the type of TV monitor being used.

NOTE

When the settings are changed, the old settings are overwritten. Make a note of the current settings before making changes. The settings are not cleared even when the vehicle's battery is disconnected.

- 1 In the stop mode, press and hold the **SETUP** button for at least 2 seconds. The setup menu appears on the monitor screen.

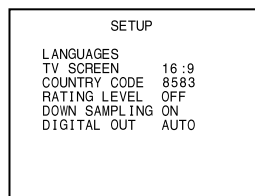

NOTE

This operation cannot be performed in the PRE-STOP mode. When the disc is being played, press the **■** button twice to set the stop mode.

- 2 Use the **Joystick** to select "TV SCREEN", then press the **ENTER** button.
- 3 Use the **Joystick** to make the selection, then press the **ENTER** button.

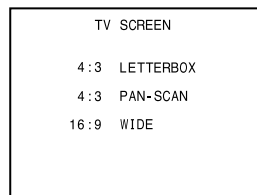

4:3 LETTERBOX

Select this when connected to a conventional 4:3 size (normal TV aspect ratio) monitor. There may be black stripes visible at the top and bottom of the screen (when playing a 16:9 size movie). The width of these stripes will depend upon the original aspect ratio of the theatrical release of the movie.



4 : 3 PAN-SCAN

Select this when connected to a conventional 4:3 size monitor. The picture will fill the entire TV screen. However, due to the mismatch in aspect ratio, parts of the movie at the extreme left and right sides will not be visible (when playing a 16 : 9 size movie).



16 : 9 WIDE

Select this when connected to a wide screen TV. This is selected upon shipment from the factory.



NOTES

- For some discs, the picture may not be set to the selected screen size. (For details, refer to the explanation on the disc's jacket.)
- Press the RTN button to return to the previous screen.

- 4** Press and hold the **SETUP** button for at least 2 seconds.
The settings are stored and the set up mode is canceled.

Changing the country code setting

Set the country code when setting the rating level (Parental lock).

NOTE

When the settings are changed, the old settings are overwritten. Make a note of the current settings before making changes. The settings are not cleared even when the vehicle's battery is disconnected.

- 1** In the stop mode, press and hold the **SETUP** button for at least 2 seconds.
The setup menu appears on the monitor screen.

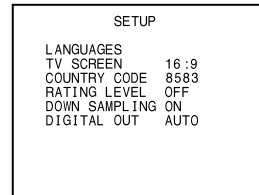

NOTE

This operation cannot be performed in the PRE-STOP mode. When the disc is being played, press the **■** button twice to set the stop mode.

- 2** Use the **Joystick** to select "COUNTRY CODE", then press the **ENTER** button.
- 3** Press the **ENTER** button to reset the country code.

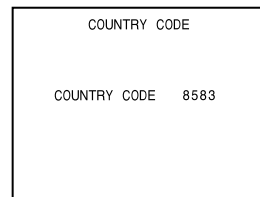

- 4** Use keys "0" to "9" to input the 4-digit country code, then press the **ENTER** button.

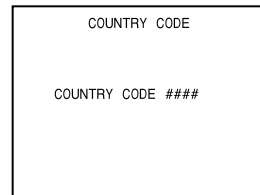

US : 8583

NOTES

- For the country codes, refer to "List of country codes" (Pages 49, 50).
- Can be erased one digit at a time each time the DEL button is pressed. Moreover, press for at least 2 seconds to delete all digits.
- Press the RTN button to return to the previous screen.

- 5** Press and hold the **SETUP** button for at least 2 seconds.
The settings are stored and the set up mode is canceled.



Tips

Operations for making the "DVD Default Settings (SETUP)" cannot be performed using the SETUP button on the main unit.

DVD Default Settings (SETUP)

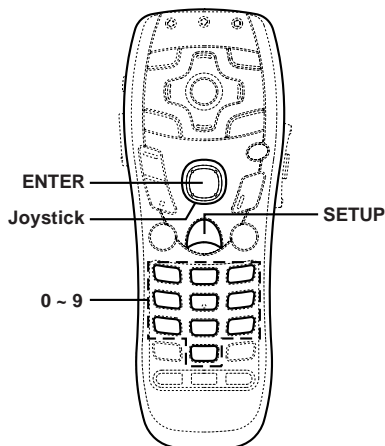

Setting the rating level (parental lock)

Use this function to restrict the viewing of movies to children of appropriate age levels only.

NOTE

When the settings are changed, the old settings are overwritten. Make a note of the current settings before making changes. The settings are not cleared even when the vehicle's battery is disconnected.

- 1 In the stop mode, press and hold the **SETUP** button for at least 2 seconds. The setup menu appears on the monitor screen.

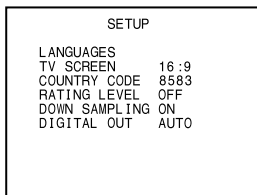

NOTE

This operation cannot be performed in the PRE-STOP mode. When the disc is being played, press the **■** button twice to set the stop mode.

- 2 Use the **Joystick** to select "RATING LEVEL", then press the **ENTER** button.
- 3 Press the **ENTER** button. The password input mode is set.

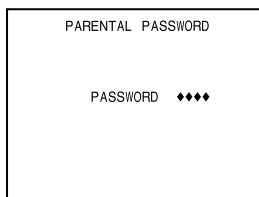

- 4 Use keys "0" to "9" to input the 4-digit password. The default password is 1111 upon shipment from the factory.

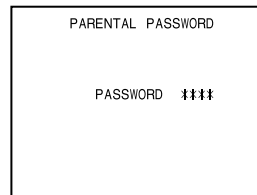

Input numbers are displayed " * ".

- 5 Press the **ENTER** button.

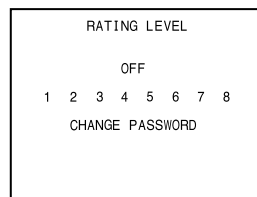

- 6 Use the **Joystick** to select the rating level, then press the **ENTER** button. Select "OFF" to cancel the parental lock or if you do not want to set a rating level. The higher the number, the higher the rating level.

NOTE

Press the **RTN** button to return to the previous screen.

- 7 Press and hold the **SETUP** button for at least 2 seconds. The settings are stored and the set up mode is canceled.

NOTES

- If you want to change the password, select "CHANGE PASSWORD", then input the new password (4 digits).
- Write down the password on a piece of paper and store the piece of paper somewhere in case you forget it.
- On unrated DVDs, playback will not be restricted even if the rating level is set.
- Once set, this rating level remains in memory until changed. To enable the play of discs of higher rating levels or to cancel the parental lock, the setting must be changed.
- Not all DVDs provide a Parental Lock feature. If you are unsure about a DVD, play it first to confirm. Do not leave DVDs accessible to young children for whom you deem them inappropriate.



- **Changing the rating level temporarily**
Some discs may request that you change the rating level set in the default settings during playback. In this case, the following message appears on the monitor screen:

Still picture

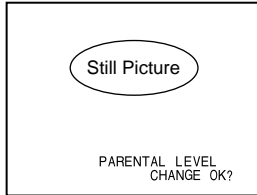

If this screen appears, change the level as follows:

- **To change parental level and play, press the ENTER button.**
- **To play without changing the parental level, press the ■ button.**
(When the ■ button is pressed, playback will be at the parental level set with "Setting Parental Lock.")

Changing the down sampling setting

Some DVDs are recorded using a 24-Bit/96 kHz linear PCM (LPCM) signal. In order to play these discs, the signal must be downsampled to 48 kHz/16 bit digital signals before being output from the optical output.

NOTE

When the settings are changed, the old settings are overwritten. Make a note of the current settings before making changes. The settings are not cleared even when the vehicle's battery is disconnected.

- 1 In the stop mode, press and hold the **SETUP** button for at least 2 seconds.
The setup menu appears on the monitor screen.

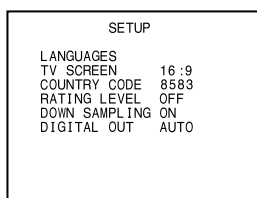

NOTE

This operation cannot be performed in the PRE-STOP mode. When the disc is being played, press the ■ button twice to set the stop mode.

- 2 Use the **Joystick** to select "DOWN SAMPLING", then press the **ENTER** button.
- 3 Move the **Joystick** up and down to choose "ON" or "OFF" and, then press the **ENTER** button.

ON

The digital signals recorded on the DVD disc with 96 kHz/24bit, 96 kHz/20bit, 96 kHz/16bit, 48 kHz/24bit, 48 kHz/20bit sampling are converted into digital signals with 48 kHz/16bits sampling for output from the optical output.
Set to ON at time of shipment from factory.

OFF

The digital signals recorded on the DVD disc with 96 kHz/24bit, 96 kHz/20bit, 96 kHz/16bit, 48 kHz/24bit, 48 kHz/20bit sampling are not converted into digital signals with 48 kHz/16bits sampling. There is no output from the optical output.

NOTE

Press the **RTN** button to return to the previous screen.

- 4 Press and hold the **SETUP** button for at least 2 seconds.
The settings are stored and the set up mode is canceled.

DVD Default Settings (SETUP)

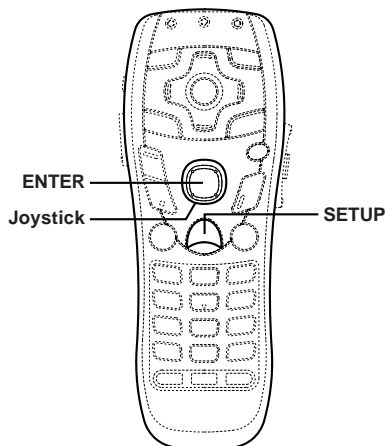

LPCM

The audio signals recorded on the disc are converted into 48 kHz/16 bit (for DVDs) or 44.1 kHz (for video CDs and CDs) linear PCM audio signals for output.

NOTE

Press the RTN button to return to the previous screen.

- 4 Press and hold the **SETUP** button for at least 2 seconds.
The set up are stored and the set up mode is canceled.

Changing the digital output setting

Use the following procedure to set the digital audio signal output from the DVA-7996.

NOTE

When the settings are changed, the old settings are overwritten. Make a note of the current settings before making changes. The settings are not cleared even when the vehicle's battery is disconnected.

- 1 In the stop mode, press and hold the **SETUP** button for at least 2 seconds.
The setup menu appears on the monitor screen.

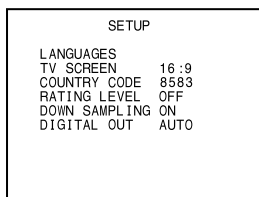

NOTE

This operation cannot be performed in the PRE-STOP mode. When the disc is being played, press the ■ button twice to set the stop mode.

- 2 Use the **Joystick** to select "DIGITAL OUT", then press the **ENTER** button.
- 3 Use the **Joystick** to make the selection, then press the **ENTER** button.

AUTO

The digital output is switched automatically according to the type of audio signals being played.

Be sure to select "AUTO" when you want to connect a digital audio processor and play Dolby Digital audio. "AUTO" is selected upon shipment from the factory.

Audio output/Optical digital audio output

Disc	Audio recording format		Digital output setting	Down sampling setting	Optical digital audio output (when a digital audio processor is connected)	Analog audio output (Ai-NET, RCA output)			
DVD	DTS		AUTO	ON	DTS Elementary Stream	OK			
				OFF	DTS Elementary Stream	OK			
			LPCM		LPCM	ON	LPCM Encode 2ch Down mix (48kHz/16bit)	OK	
						OFF	LPCM Encode 2ch Down mix (48kHz/16bit)	OK	
	Dolby Digital		AUTO	ON	Dolby Digital	OK			
				OFF	Dolby Digital	OK			
			LPCM		LPCM	ON	LPCM (48kHz/16bit)	OK	
						OFF	LPCM (48kHz/16bit)	OK	
	Linear PCM	48kHz/16bit	AUTO	ON	LPCM (48kHz/16bit)	OK			
				OFF	LPCM (48kHz/16bit)	OK			
			LPCM		LPCM	ON	LPCM (48kHz/16bit)	OK	
						OFF	LPCM (48kHz/16bit)	OK	
			48kHz/20bit	AUTO	ON	LPCM (48kHz/16bit)	OK		
					OFF	LPCM (48kHz/16bit)	OK		
		LPCM		LPCM	ON	LPCM (48kHz/16bit)	OK		
					OFF	LPCM (48kHz/16bit)	OK		
		48kHz/24bit		AUTO	ON	LPCM (48kHz/16bit)	OK		
					OFF	X	OK		
			LPCM		LPCM	ON	LPCM (48kHz/16bit)	OK	
						OFF	LPCM (48kHz/16bit)	OK	
			96kHz/16bit	AUTO	ON	LPCM (48kHz/16bit)	OK		
					OFF	X	OK		
		LPCM		LPCM	ON	LPCM (48kHz/16bit)	OK		
					OFF	LPCM (48kHz/16bit)	OK		
		96kHz/20bit		AUTO	ON	LPCM (48kHz/16bit)	OK		
					OFF	X	OK		
			LPCM		LPCM	ON	LPCM (48kHz/16bit)	OK	
						OFF	LPCM (48kHz/16bit)	OK	
			96kHz/24bit	AUTO	ON	LPCM (48kHz/16bit)	OK		
					OFF	X	OK		
		LPCM		LPCM	ON	LPCM (48kHz/16bit)	OK		
					OFF	LPCM (48kHz/16bit)	OK		
	MPEG2			AUTO or LPCM	ON or OFF	LPCM (48kHz/16bit)	OK		
	MPEG1			AUTO or LPCM	ON or OFF	LPCM (44.1kHz)	OK		
	Video CD	Linear PCM		AUTO or LPCM	ON or OFF	LPCM (44.1kHz)	OK		
	CD	DTS		AUTO	ON	DTS Elementary Stream	OK		
					OFF	DTS Elementary Stream	OK		
				LPCM		LPCM	ON	LPCM Encode 2ch Down mix (48kHz/16bit)	OK
							OFF	LPCM Encode 2ch Down mix (48kHz/16bit)	OK
	MP3	MPEG Audio Layer3 Bit Rate: 32kbps~ 320kbps	32kHz/16bit	AUTO or LPCM	ON or OFF	LPCM Encode 2ch (32kHz/16bit)	OK		
44.1kHz/16bit			AUTO or LPCM	ON or OFF	LPCM Encode 2ch (44.1kHz/16bit)	OK			
48kHz/16bit			AUTO or LPCM	ON or OFF	LPCM Encode 2ch (48kHz/16bit)	OK			

DVD Default Settings (SETUP)

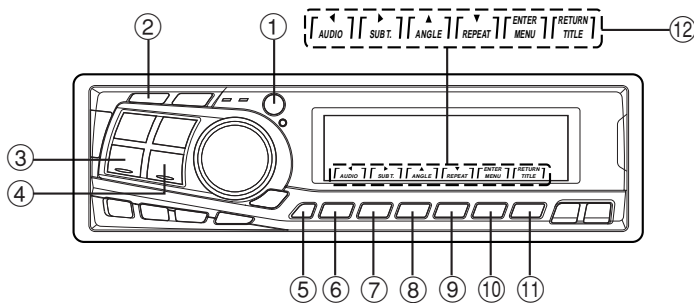

Operating DVDs and video CDs using the front panel

- ① **Rear DVD Button (page 34)**
Change the setting of the rear DVD function.
Press and hold for at least 2 seconds to switch the remote control sensor.
- ② **▶/⏸ Button (pages 30, 31)**
Pause/Playback
- ③ **⏮ DN Button (pages 30)**
 - Move to the desired position on the disc.
 - During playback, press and hold for more than 1 second to reverse the disc at double speed. Hold for more than 5 seconds to reverse the disc at 8 times the normal speed.
- ④ **▶▶ UP Button (pages 30, 31)**
 - Move to the desired position on the disc.
 - During playback, press and hold for more than 1 second to forward the disc at double speed. Hold for more than 5 seconds to forward the disc at 8 times the normal speed.
 - When pressed and held in while in the pause mode, the disc is played in slow motion at 1/8th the normal speed. When held in for 5 more seconds, the slow motion speed switches to 1/2 the normal speed.
 - The picture is forwarded by one frame each time the button is pressed in the pause mode.
- ⑤ **F Button**
The DVD/video CD indicator upper level/lower level mode operation switches each time the button is pressed.
- ⑥ **1 Button**
 - In DVD mode
Indicator upper row (◀): Selects the item displayed on the screen (left direction).
Indicator lower row (AUDIO) : Switches the audio tracks. (page 32)
 - In Video CD mode
Indicator upper row (◀): Cannot be used.
Indicator lower row (AUDIO) : Switches the audio tracks. (page 32)
- ⑦ **2 Button**
 - In DVD mode
Indicator upper row (▶): Selects the item displayed on the screen (right direction).
Indicator lower row (SUB T.) : Switches the subtitle. (page 33)
 - In Video CD mode
Indicator upper row (▶): Cannot be used.
Indicator lower row (SUB T.) : Cannot be used.
- ⑧ **3 Button**
 - In DVD mode
Indicator upper row (▲): Selects the item displayed on the screen (upper direction).
Indicator lower row (ANGLE) : Switches the angle of the picture. (page 32)
- In Video CD mode
Indicator upper row (▲): Cannot be used.
Indicator lower row (ANGLE) : Cannot be used.
- ⑨ **4 Button**
 - In DVD mode
Indicator upper row (▼): Selects the item displayed on the screen (lower direction).
Indicator lower row (REPEAT) : Repeats playback. (page 31)
 - In Video CD mode
Indicator upper row (▼): Cannot be used.
Indicator lower row (REPEAT) : Repeats playback. (Only when PBC is OFF) (page 31)
- ⑩ **5 Button**
 - In DVD mode
Indicator upper row (ENTER) : Selects the item displayed on the screen.
Indicator lower row (MENU) : Displays the DVD menu.
 - In Video CD mode
Indicator upper row (ENTER) : Cannot be used.
Indicator lower row (MENU) : PBC ON/OFF switch (Only Video CD with PBC function)
- ⑪ **6 Button**
 - In DVD mode
Indicator upper row (RETURN) : Returns to the previous selection screen.
Indicator lower row (TITLE) : Displays the title menu.
 - In Video CD mode
Indicator upper row (RETURN) : Returns to the previous selection screen. (Only when PBC is ON)
Indicator lower row (TITLE) : Cannot be used.
- ⑫ **DVD/Video CD Indicator**
The DVD or Video CD playback Indicator lights.
 - Indicator upper row
The same operation as the upper level indicator operation (remote control unit and joystick, ENTER and RETURN) can be performed by pressing "F" button once while playing a DVD then pressing "1" to "6" button. When playing a video CD, however (when PBC is turned on), only the RETURN operation is possible.
 - Indicator lower row
The lower level indicator operation can be performed by pressing "1" to "6" button while playing a DVD/video CD. When playing a video CD, however, only the AUDIO, MENU (for Video CDs with PBC functions) and REPEAT (only when PBC is turned off) operations are possible.

NOTE

You may not be able to operate according to the disc.

Remote Control Operation

Operating audio for the DVA-7996

Set the mode selector switch to the "AUDIO" side to perform audio operations on the DVA-7996.

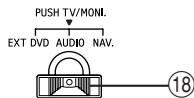
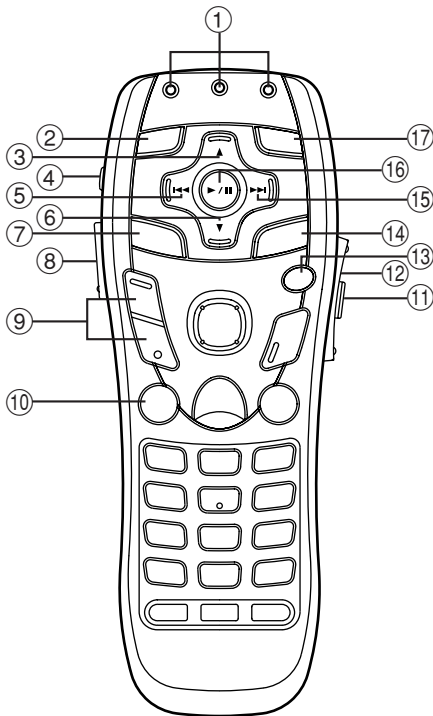

(Rear of the Remote Control)

- ① **AUDIO/NAV./EXT DVD Transmission Indicator**
When the mode selector switch is switched, the transmission indicators for the various modes light for several seconds.
- ② **A.PROC Button****
Press the button to call the external audio processor mode.*
- ③ **▲ Button**
Radio mode: Pressing the button will select, in ascending order, stations programmed into the radio's presets.
MP3 mode: Press the Folder Select (UP) Button to select the folder.
CD Changer mode: DISC Select (UP) Button
Press the button to select a disc in ascending order.
- ④ **POWER Button**
Press the button to turn the power on/off.
- ⑤ **◀◀ Button**
Radio mode: SEEK (DN) Button

- ⑥ **▼ Button**
Radio mode: Pressing the button will select, in descending order, stations programmed into the radio's presets.
MP3 mode: Press the Folder Select (DN) Button to select the folder.
CD Changer mode: DISC Select (DN) Button
Press the button to select a disc in descending order.
- ⑦ **V.SEL Button**
Used for switching the screen when the unit is used in combination with a separately sold monitor, etc.
- ⑧ **LIGHT Button**
Lights the indicator.
- ⑨ **VOLUME ▲ / ▼ Button**
To increase or decrease the volume level.
- ⑩ **MUTE Button**
Press the button to lower the volume by 20 dB instantly. Press the button again to cancel.
- ⑪ **REAR Button**
Press and hold for at least 2 seconds to switch the remote control sensor.
- ⑫ **ANGLE ▲ / ▼ Button**
Press the button to adjust the angle of the movable audio display.
- ⑬ **■ Button**
Performs stop.
- ⑭ **SOURCE Button**
Press to select the audio source.
- ⑮ **▶▶ Button**
Radio mode: SEEK (UP) Button
CD changer mode: Press the button to advance to the beginning of the next track. Press and hold to fast forward.
MP3 mode: Press the button to advance to the beginning of the next file.
- ⑯ **▶/|| Button**
Press the button to switch between play and pause.
- ⑰ **BAND Button**
Radio mode:
Press the button and the band will change.
CD/Changer mode: To switch the disc mode.
- ⑱ **MODE Change Switch**
Set to the "AUDIO" side to operate the DVA-7996.
Set to the "EXT DVD" side to operate a separately sold DVD product.
Set to the "NAV." side to operate a separately sold navigation product.
When pressed, the mode switches to the TV mode.
Operate while the transmission indicator is flashing.

* For the operation of external audio processor, refer to the Owner's Manual of the external audio processor you purchased.
** This button is used in conjunction with an optional Ai-NET processor.

Remote Control Operation

Operating the DVD player/DVD changer (sold separately)

Set the mode selector switch to the "EXT DVD" side to operate a separately sold DVD player or DVD changer.

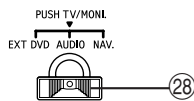
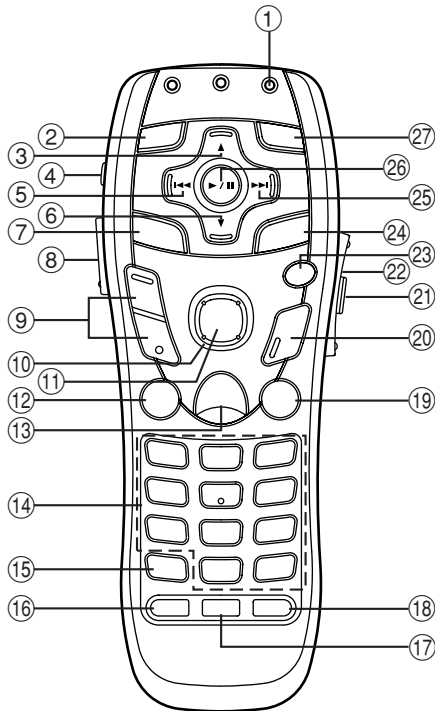

(Rear of the Remote Control)

- ① **EXT DVD Transmission Indicator**
If the mode switch is switched to the EXT DVD side, the transmission indicator flashes for few seconds.
- ② **A.PROC Button**
Press the button to call the external audio processor mode.
- ③ **▲ Button**
Disc No. UP (Only for DVD changer)
- ④ **POWER Button**
Press the button to turn the power on/off.
Press and hold for at least 5 seconds to switch the NTSC/PAL.
- ⑤ **◀◀ Button**
Starts playback from the beginning of the current chapter or track.
Press and hold for at least 2 seconds to fast-reverse the chapter or track.
- ⑥ **▼ Button**
Disc No. DOWN (Only for DVD changer)
- ⑦ **V.SEL Button**
Switches the screen of TV or DVD video.

- ⑧ **LIGHT Button**
Lights the indicator.
- ⑨ **VOLUME ^ / ∨ Button**
Adjusts the volume of the DVA-7996.
- ⑩ **Joystick**
Selects the item displayed on the screen.
- ⑪ **ENTER Button**
Decides the selected item.
- ⑫ **MUTE Button**
Decreases the volume of DVA-7996 in a moment. Press the button again to cancel.
- ⑬ **MENU/SETUP Button**
Displays the DVD menu.
Press and hold for at least 2 seconds to access SETUP (initial setting).
- ⑭ **Numeric Keypad**
Inputs numbers
- ⑮ **DEL. Button**
Deletes one digit of the selected/inputted numbers.
Press and hold for at least 2 seconds to delete all of the selected/inputted numbers.
- ⑯ **AUDIO Button**
Switches the audio tracks.
- ⑰ **SUB T. Button**
Switches the subtitle.
Press and hold for at least 2 seconds to turn ON/OFF the subtitle display.
- ⑱ **ANGLE Button**
Switches the angle.
- ⑲ **RTN Button**
Returns to the previous selection screen.
- ⑳ **DISP/TITLE Button**
Starts playback from the beginning of chapter/track/elapsed time.
Press and hold for at least 2 seconds to display the title menu.
- ㉑ **REAR Button**
Outputs the DVD video on the monitor during other source.
- ㉒ **ANGLE ^ / ∨ Button**
To change the audio display angle.
- ㉓ **■ Button**
Performs PRE STOP. Press again to cancel PRE STOP and stop the playback.
- ㉔ **SOURCE Button**
Press to select the audio source.
- ㉕ **▶▶ Button**
Starts playback from the beginning of the following chapter or track.
Press and hold for at least 2 seconds to fast forward the chapter or track.
- ㉖ **▶/|| Button**
Performs playback.
Press and hold for at least 2 seconds for slow motion playback.
- ㉗ **BAND Button**
Switches the band of the audio side or the disc mode.
- ㉘ **MODE Change Switch**
When operating the connected DVD player/DVD changer, switch to the EXT DVD side.

NOTE

Depending on the disc or playback status, certain operations may not work. In this case, the ⓪ mark is displayed on the monitor screen.

Operating the Navigation (sold separately)

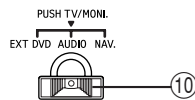
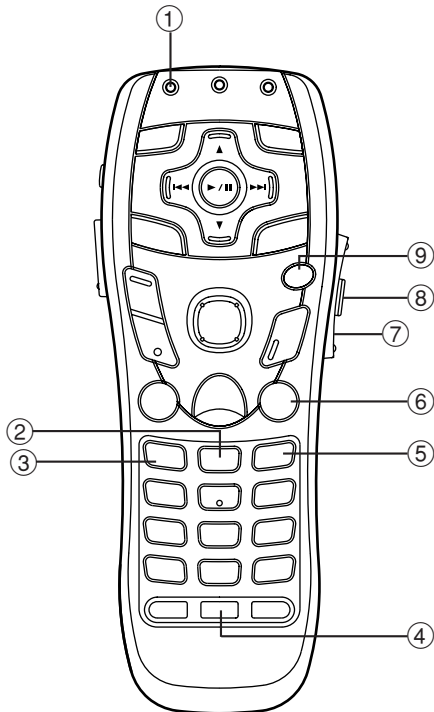

(Rear of the Remote Control)

- ⑦ **SCALE UP/DN Buttons**
- ⑧ **VOICE Button**
Initiates vocal instruction for next route maneuver or repeats last instruction.
- ⑨ **MODE Button**
Press this button to input numerals using the numeric keypad, DEL. and +10 buttons. After pressing the MODE button, the following buttons will be pressed while the status indicator is blinking: numerals (0-9), DEL. and +10.
- ⑩ **Mode change switch**
Set this switch to the "NAV." side to operate a connected Alpine navigation system.

Operating a sold separately TV monitor

- To operate a separately sold Alpine TV monitor, press the mode change switch on the rear of the remote control unit. Operate while the transmission indicator is blinking.
- Included remote control unit operation seal: Apply the seal for the type of TV monitor you are using to the rear of the remote control unit.

NOTE

Operation may differ or may not be possible for some products. Also refer to the product's operating instructions.

- ① **NAV. transmission indicator**
The transmission indicator lights for few seconds when the mode selector switch is set to the "NAV." side.
- ② **DTR (DETOUR) Button**
Automatically recalculates route if a road block or traffic congestion is encountered.
- ③ **LIST Button**
Displays list of the streets currently set for the route. To return to the guidance mode, press the DISP button.
- ④ **DEL DEST. Button**
Deletes current destination.
- ⑤ **N/H Button**
Toggles between North UP and Heading UP orientation.
- ⑥ **CANC. Button**
Cancels current display screen and switches back to previous screen with menus.

Information

About DVDs

Music CDs and DVDs have grooves (tracks) in which the digital data is recorded. The data is represented as microscopic pits recorded into the track – these pits are read by a laser beam to play the disc. On DVDs, the density of the tracks and pits is twice that of CDs, so DVDs can contain more data in less space.

CDs

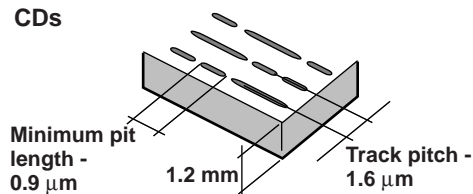

DVDs

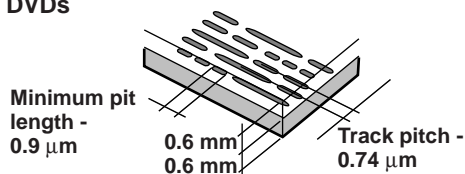

A 12 cm disc can contain one movie or about four hours of music.

In addition, DVDs provide sharp picture quality with vivid colors thanks to a horizontal resolution of over 500 lines (compared to less than 300 for VHS tape). With the addition of an optional, digital audio processor (PXA-H900/PXA-H510/PXA-H700), you can recreate the power and presence of a movie theater with Dolby Digital 5.1-channel Surround.

Moreover, DVDs offer a variety of functions.

- **Multiple audio*** (page 32)

Movies can be recorded in up to eight languages. The desired language can be selected from the remote control unit.

- **Subtitles function*** (page 33)

Movies can include subtitles in up to 32 languages. The desired subtitle language can be selected from the remote control unit.

- **Multi angle function*** (page 32)

When the DVD contains a movie shot from multiple angles, the desired angle can be selected from the remote control unit.

- **Multi story function***

With this function, a single movie includes various story lines. You can select different story lines to view various versions of the same movie.

Operation differs from disc to disc. Story line selection screens including instructions appear during the movie. Just follow the instructions.

NOTE

* The functions audio languages, subtitle languages, angles, etc., differ from disc to disc. For details, refer to the disc's instructions.

Terminology

Dolby Digital

Dolby Digital is a digital audio compression technology developed by Dolby Laboratories that allows large quantities of audio data to be efficiently recorded on discs. It is compatible with audio signals from mono (1 channel) all the way up to 5.1-channel surround sound. The signals for the different channels are completely independent, and since the sound is high quality digital there is no loss of sound quality.

* The separately sold digital audio processor (PXA-H510/PXA-H900/PXA-H700) is required to enjoy full 5.1-channel surround sound.

The DVA-7996 performs Dolby Digital decoding when it outputs analog audio signals, it just happens to be 2-channel audio not 5.1-channel.

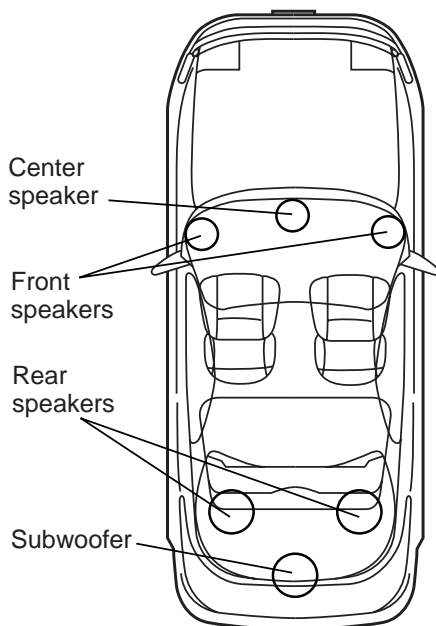

Speaker layout for enjoying Dolby Digital sound/dts sound

DTS

This is a home-use digital sound format of the DTS Sound System. This is a high quality sound system, developed by Digital Theater Systems Corp for use in movie theaters.

DTS has six independent sound tracks. The theater presentation is fully realized in the home and other settings. DTS is the abbreviation for Digital Theater System.

* To enjoy DTS surround sound you need the separately sold DTS digital audio processor (PXA-H900/PXA-H700). The DVD video software must also have a DTS sound track.

Dolby Pro Logic

Dolby Pro Logic is the technology used to decode programs encoded in Dolby Surround. Pro logic decoding will provide you with four channels of sound (front left/right, center and monaural rear surround) from a 2-channel (stereo) source.

* The separately sold digital audio processor (PXA-H510/PXA-H900) is required to enjoy Dolby Pro Logic surround sound.

Dolby Pro Logic II

Dolby Pro Logic II plays 2-channel sources in 5 channels over the entire frequency range. This is done with an advance, high sound quality matrix surround decoder which draws out the spatial properties of the original recording without adding any sounds to or changing the sound of the source.

* The separately sold digital audio processor (PXA-H700) is required to enjoy Dolby Pro Logic II surround sound.

Linear PCM audio (LPCM)

LPCM is a signal recording format used for music CDs. Whereas music CDs are recorded at 44.1 kHz/16 bits, DVDs are recorded at 48 kHz/16 bits to 96 kHz/24 bits, thereby achieving higher sound quality than music CDs.

Rating levels (parental lock)

This is a function of the DVD for restricting the viewing age as stipulated by laws in different countries. The way in which viewing is restricted differs from DVD to DVD. Sometimes the DVD cannot be played at all, other times certain scenes are skipped, and other times certain scenes are replaced with other scenes.

Information

List of language codes

(For details, see pages 35, 36.)

Abbreviation	Code	Language	Abbreviation	Code	Language	Abbreviation	Code	Language
AA	6565	Afar	IE	7369	Interlingue	RN	8278	Kirundi
AB	6566	Abkhazian	IK	7375	Inupiak	RO	8279	Romanian
AF	6570	Afrikaans	IN	7378	Indonesian	RU	8285	Russian
AM	6577	Amharic	IS	7383	Icelandic	RW	8287	Kinyarwanda
AR	6582	Arabic	IT	7384	Italian	SA	8365	Sanskrit
AS	6583	Assamese	IW	7387	Hebrew	SD	8368	Sindhi
AY	6589	Aymara	JA	7465	Japanese	SG	8371	Sangho
AZ	6590	Azerbaijani	JL	7473	Yiddish	SH	8372	Serbo-Croatian
BA	6665	Bashkir	JW	7487	Javanese	SI	8373	Singhalese
BE	6669	Byelorussian	KA	7565	Georgian	SK	8375	Slovak
BG	6671	Bulgarian	KK	7575	Kazakh	SL	8376	Slovenian
BH	6672	Bihari	KL	7576	Greenlandic	SM	8377	Samoan
BI	6673	Bislama	KM	7577	Cambodian	SN	8378	Shona
BN	6678	Bengali, Bangla	KN	7578	Kannada	SO	8379	Somali
BO	6679	Tibetan	KO	7579	Korean	SQ	8381	Albanian
BR	6682	Breton	KS	7583	Kashmiri	SR	8382	Serbian
CA	6765	Catalan	KU	7585	Kurdish	SS	8383	Siswati
CO	6779	Corsican	KY	7589	Kirghiz	ST	8384	Sesotho
CS	6783	Czech	LA	7665	Latin	SU	8385	Sundanese
CY	6789	Welsh	LN	7678	Lingala	SV	8386	Swedish
DA	6865	Danish	LO	7679	Laothian	SW	8387	Swahili
DE	6869	German	LT	7684	Lithuanian	TA	8465	Tamil
DZ	6890	Bhutani	LV	7686	Latvian, Lettish	TE	8469	Telugu
EL	6976	Greek	MG	7771	Malagasy	TG	8471	Tajik
EN	6978	English	MI	7773	Maori	TH	8472	Thai
EO	6979	Esperanto	MK	7775	Macedonian	TI	8473	Tigrinya
ES	6983	Spanish	ML	7776	Malayalam	TK	8475	Turkmen
ET	6984	Estonian	MN	7778	Mongolian	TL	8476	Tagalog
EU	6985	Basque	MO	7779	Moldavian	TN	8478	Setswana
FA	7065	Persian	MR	7782	Marathi	TO	8479	Tonga
FI	7073	Finnish	MS	7783	Malay	TR	8482	Turkish
FJ	7074	Fiji	MT	7784	Maltese	TS	8483	Tsonga
FO	7079	Faroese	MY	7789	Burmese	TT	8484	Tatar
FR	7082	French	NA	7865	Nauru	TW	8487	Twi
FY	7089	Frisian	NE	7869	Nepali	UK	8575	Ukrainian
GA	7165	Irish	NL	7876	Dutch	UR	8582	Urdu
GD	7168	Scots Gaelic	NO	7879	Norwegian	UZ	8590	Uzbek
GL	7176	Galician	OC	7967	Occitan	VI	8673	Vietnamese
GN	7178	Guarani	OM	7977	(Afan) Oromo	VO	8679	Volapuk
GU	7185	Gujarati	OR	7982	Oriya	WO	8779	Wolof
HA	7265	Hausa	PA	8065	Punjabi	XH	8872	Xhosa
HI	7273	Hindi	PL	8076	Polish	YO	8979	Yoruba
HR	7282	Croatian	PS	8083	Pashto, Pushto	ZH	9072	Chinese
HU	7285	Hungarian	PT	8084	Portuguese	ZU	9085	Zulu
HY	7289	Armenian	QU	8185	Quechua			
IA	7365	Interlingua	RM	8277	Rhaeto-Romance			

List of country codes

(For details, see page 37.)

Abbreviation	Code	Country	Abbreviation	Code	Country	Abbreviation	Code	Country
AD	6568	Andorra	DM	6877	Dominica	KI	7573	Kiribati
AE	6569	United Arab Emirates	DO	6879	Dominican Republic	KM	7577	Comoros
AF	6570	Afghanistan	DZ	6890	Algeria	KN	7578	Saint Kitts and Nevis
AG	6571	Antigua and Barbuda	EC	6967	Ecuador	KP	7580	Korea, Democratic People's Republic of
AI	6573	Anguilla	EE	6969	Estonia			
AL	6576	Albania	EG	6971	Egypt	KR	7582	Korea, Republic of
AM	6577	Armenia	EH	6972	Western Sahara	KW	7587	Kuwait
AN	6578	Netherlands Antilles	ER	6982	Eritrea	KY	7589	Cayman Islands
AO	6579	Angola	ES	6983	Spain	KZ	7590	Kazakstan
AQ	6581	Antarctica	ET	6984	Ethiopia	LA	7665	Lao People's Democratic Republic
AR	6582	Argentina	FI	7073	Finland			
AS	6583	American Samoa	FJ	7074	Fiji	LB	7666	Lebanon
AT	6584	Austria	FK	7075	Falkland Islands	LC	7667	Saint Lucia
AU	6585	Australia	FM	7077	Micronesia, Federated States of	LI	7673	Liechtenstein
AW	6587	Aruba	FO	7079	Faroe Islands	LK	7675	Sri Lanka
AZ	6590	Azerbaijan	FR	7082	France	LR	7682	Liberia
BA	6665	Bosnia and Herzegovina	GA	7165	Gabon	LS	7683	Lesotho
BB	6666	Barbados	GB	7166	United Kingdom	LT	7684	Lithuania
BD	6668	Bangladesh	GD	7168	Grenada	LU	7685	Luxembourg
BE	6669	Belgium	GE	7169	Georgia	LV	7686	Latvia
BF	6670	Burkina Faso	GF	7170	French Guiana	LY	7689	Libyan Arab Jamahiriya
BG	6671	Bulgaria	GH	7172	Ghana	MA	7765	Morocco
BH	6672	Bahrain	GI	7173	Gibraltar	MC	7767	Monaco
BI	6673	Burundi	GL	7176	Greenland	MD	7768	Moldova, Republic of
BJ	6674	Benin	GM	7177	Gambia	MG	7771	Madagascar
BM	6677	Bermuda	GN	7178	Guinea	MH	7772	Marshall Islands
BN	6678	Brunei Darussalam	GP	7180	Guadeloupe	MK	7775	Macedonia, The former Yugoslav Republic of
BO	6679	Bolivia	GQ	7181	Equatorial Guinea			
BR	6682	Brazil	GR	7182	Greece	ML	7776	Mali
BS	6683	Bahamas	GS	7183	South Georgia and the South Sandwich Islands	MM	7777	Myanmar
BT	6684	Bhutan				MN	7778	Mongolia
BV	6686	Bouvet Island	GT	7184	Guatemala	MO	7779	Macau
BW	6687	Botswana	GU	7185	Guam	MP	7780	Northern Mariana Islands
BY	6689	Belarus	GW	7187	Guinea-Bissau	MQ	7781	Martinique
BZ	6690	Belize	GY	7189	Guyana	MR	7782	Mauritania
CA	6765	Canada	HK	7275	Hong Kong	MS	7783	Montserrat
CC	6767	Cocos (Keeling) Islands	HM	7277	Heard Island and McDonald Islands	MT	7784	Malta
CD	6768	Congo, the Democratic Republic of the				MU	7785	Mauritius
CF	6770	Central African Republic	HN	7278	Honduras	MV	7786	Maldives
CG	6771	Congo	HR	7282	Croatia	MW	7787	Malawi
CH	6772	Switzerland	HT	7284	Haiti	MX	7788	Mexico
CI	6773	Cote d'Ivoire	HU	7285	Hungary	MY	7789	Malaysia
CK	6775	Cook Islands	ID	7368	Indonesia	MZ	7790	Mozambique
CL	6776	Chile	IE	7369	Ireland	NA	7865	Namibia
CM	6777	Cameroon	IL	7376	Israel	NC	7867	New Caledonia
CN	6778	China	IN	7378	India	NE	7869	Niger
CO	6779	Colombia	IO	7379	British Indian Ocean Territory	NF	7870	Norfolk Island
CR	6782	Costa Rica	IQ	7381	Iraq	NG	7871	Nigeria
CU	6785	Cuba	IR	7382	Iran, Islamic Republic of	NI	7873	Nicaragua
CV	6786	Cape Verde	IS	7383	Iceland	NL	7876	Netherlands
CX	6788	Christmas Island	IT	7384	Italy	NO	7879	Norway
CY	6789	Cyprus	JM	7477	Jamaica	NP	7880	Nepal
CZ	6790	Czech Republic	JO	7479	Jordan	NR	7882	Nauru
DE	6869	Germany	JP	7480	Japan	NU	7885	Niue
DJ	6874	Djibouti	KE	7569	Kenya	NZ	7890	New Zealand
DK	6875	Denmark	KG	7571	Kyrgyzstan	OM	7977	Oman
			KH	7572	Cambodia	PA	8065	Panama

Continued

Information

Abbreviation	Code	Country	Abbreviation	Code	Country	Abbreviation	Code	Country
PE	8069	Peru	SJ	8374	Svalbard and Jan Mayen	TW	8487	Taiwan, Province of China
PF	8070	French Polynesia	SK	8375	Slovakia	TZ	8490	Tanzania, United Republic of
PG	8071	Papua New Guinea	SL	8376	Sierra Leone	UA	8565	Ukraine
PH	8072	Philippines	SM	8377	San Marino	UG	8571	Uganda
PK	8075	Pakistan	SN	8378	Senegal	UM	8577	United States Minor Outlying Islands
PL	8076	Poland	SO	8379	Somalia	US	8583	United States
PM	8077	Saint Pierre and Miquelon	SR	8382	Suriname	UY	8589	Uruguay
PN	8078	Pitcairn	ST	8384	Sao Tome and Principe	UZ	8590	Uzbekistan
PR	8082	Puerto Rico	SV	8386	El Salvador	VA	8665	Holy See (Vatican City State)
PT	8084	Portugal	SY	8389	Syrian Arab Republic	VC	8667	Saint Vincent and the Grenadines
PW	8087	Palau	SZ	8390	Swaziland	VE	8669	Venezuela
PY	8089	Paraguay	TC	8467	Turks and Caicos Islands	VG	8671	Virgin Island, British
QA	8165	Qatar	TD	8468	Chad	VI	8673	Virgin Islands, U.S
RE	8269	Reunion	TF	8470	French Southern Territories	VN	8678	Viet Nam
RO	8279	Romania	TG	8471	Togo	VU	8685	Vanuatu
RU	8285	Russian Federation	TH	8472	Thailand	WF	8770	Wallis and Futuna
RW	8287	Rwanda	TJ	8474	Tajikistan	WS	8783	Samoa
SA	8365	Saudi Arabia	TK	8475	Tokelau	YE	8969	Yemen
SB	8366	Solomon Islands	TM	8477	Turkmenistan	YT	8984	Mayotte
SC	8367	Seychelles	TN	8478	Tunisia	YU	8985	Yugoslavia
SD	8368	Sudan	TO	8479	Tonga	ZA	9065	South Africa
SE	8369	Sweden	TP	8480	East Timor	ZM	9077	Zambia
SG	8371	Singapore	TR	8482	Turkey	ZW	9087	Zimbabwe
SH	8372	Saint Helena	TT	8484	Trinidad and Tobago			
SI	8373	Slovenia	TV	8486	Tuvalu			

In Case of Difficulty

If you encounter a problem, please turn the power off, then on again. If the unit is still not functioning normally, please review the items in the following checklist. This guide will help you isolate the problem if the unit is at fault. Otherwise, make sure the rest of your system is properly connected or consult your authorized Alpine dealer.

Basic

No function or display.

- Vehicle's ignition is off.
 - If connected following instructions, the unit will not operate with the vehicle's ignition off.
- Improper power lead connections.
 - Check power lead connections.
- Blown fuse.
 - Check the fuse on the battery lead of the unit; replace with the proper value if necessary.
- Internal micro-computer malfunctioned due to interference noise etc.
 - Press the RESET switch with a ballpoint pen or other pointed article.

Radio

Unable to receive stations.

- No antenna or open connection in cable.
 - Make sure the antenna is properly connected; replace the antenna or cable if necessary.

Unable to tune stations in the seek mode.

- You are in a weak signal area.
 - Make sure the tuner is in the DX mode.
- If the area you are in is a primary signal area, the antenna may not be grounded and connected properly.
 - Check your antenna connections; make sure the antenna is properly grounded at its mounting location.
- The antenna may not be the proper length.
 - Make sure the antenna is fully extended; if broken, replace the antenna with a new one.

Broadcast is noisy.

- The antenna is not the proper length.
 - Extend the antenna fully; replace it if it is broken.
- The antenna is poorly grounded.
 - Make sure the antenna is grounded properly at its mounting location.

CD/MP3/DVD/Video CD

Disc playback sound is wavering.

- Moisture condensation in the disc Module.
 - Allow enough time for the condensation to evaporate (about 1 hour).

Disc insertion not possible.

- A disc is already in the DVD player.
 - Eject the disc and remove it.
- The disc is being improperly inserted.
 - Make sure the disc is being inserted following instructions in the CD (MP3/DVD/Video CD) Player Operation section.

Unable to fast forward or backward the disc.

- The disc has been damaged.
 - Eject the disc and discard it; using a damaged disc in your unit can cause damage to the mechanism.

Disc playback sound skips due to vibration.

- Improper mounting of the unit.
 - Securely re-mount the unit.
- Disc is very dirty.
 - Clean the disc.
- Disc has scratches.
 - Change the disc.
- The pick-up lens is dirty.
 - Do not use a commercial available lens cleaner disc. Consult your nearest ALPINE dealer.

Disc playback sound skips without vibration.

- Dirty or scratched disc.
 - Clean the disc; damaged disc should be replaced.

Error displays

- Mechanical error
 - Press the ▲ button. After the error indication disappears, insert the disc again. If the above-mentioned solution does not solve the problem, consult your nearest ALPINE dealer.

MP3 is not played back.

- Writing error occurred. The CD format is not compatible.
 - Make sure the CD has been written in a supported format. Refer to "About MP3" on pages 25-26, then rewrite in the format supported by this device.

Unit does operate.

- Monitor's power is not turned on.
 - Turn on the monitor's power.
- Condensation.
 - Wait a while (about 1 hour) for the condensation to dry.

No picture is produced.

- Monitor's mode is not switched to the mode you want to see.
 - Switch to the mode you want to see.
- Monitor's parking brake cord is not connected.
 - Connect the monitor's parking brake cord and set the parking brake.
(For details, refer to the monitor's instructions.)
- Monitor's parking brake is not set.
 - Connect the monitor's parking brake cord and set the parking brake.
(For details, refer to the monitor's instructions.)

Playback does not start.

- Disc is loaded upside-down.
 - Check the disc and load it with the labeled side facing upward.
- Disc is dirty.
 - Clean the disc.
- A disc not able to playback with this unit is loaded.
 - Check if the disc is able to be played back.
- Parental lock is set.
 - Cancel the parental lock or change the rating level.
- Setup menu is displayed.
 - Press "SETUP" for at least 2 seconds to turn the menu off.

Continued

51-EN

Information

Picture is unclear or noisy.

- Disc is being fast-forwarded or fast-reversed.
 - The picture may be slightly disturbed, but this is normal.
- Vehicle's battery power is weak.
 - Check the battery power and wiring.
(The unit may malfunction if the battery power is under 11 volts with a load applied.)
- Monitor's fluorescent tube is worn.
 - Replace the monitor's fluorescent tube.

Image stops sometimes.

- Disc is scratched.
 - Replaced with a non-scratched disc.

Indication for CD/MP3

HI TEMP

- Protective circuit is activated due to high temperature.
 - The indicator will disappear when the temperature returns to within operation range.
 - Leave the power OFF until the temperature decreases and then turn the power ON again.

NO DISC

- No disc is inserted.
 - Insert a disc.
- Although a disc is inserted, "NO DISC" is displayed and the unit does not start to play or eject the disc.
 - Remove the disc by following these steps:
 - 1) Press the **▲** button.
The movable display will open.
 - 2) Press the **▲** button again for at least 3 seconds while the movable display is open.

ERROR

- Mechanism error.
 - 1) Press the **▲** button and eject the CD.
If not ejecting, consult your Alpine dealer.
 - 2) When the error indication remains after ejecting, press the **▲** button again.
If the error indication still does not turn off after pressing the **▲** button for a few times, consult your Alpine dealer.
- The temperature in the car is too low.
 - Raise the temperature in the car to normal temperature.

NOTE

When the "ERROR" is displayed:

In case that the disc cannot be ejected by pressing the **▲** button, press the **RESET** switch (refer to page 7) and press the **▲** button again.

If not ejecting, consult your Alpine dealer.

Indication for DVD/Video CD

NO DISC

(Audio display)

- No disc is inserted.
 - Insert a disc.
- Although a disc is inserted, "NO DISC" is displayed and the unit does not start to play or eject the disc.
 - Remove the disc by following these steps:
 - 1) Press the **▲** button.
The movable display will open.
 - 2) Press the **▲** button again for at least 3 seconds while the movable display is open.



(Monitor display)

- Remote control operation is not possible.
 - For some discs or playing modes, certain operations are not possible. This is not a malfunction.

REGIONAL CODE VIOLATION

(Monitor display)

ERROR

(Audio display)

- Disc does not match regional code number.
 - Load a disc that matches the regional code number.

VIDEO SIGNAL SYSTEM IS NOT CORRECT

(Monitor display)

ERROR

(Audio display)

- PAL disc is loaded.
 - Load an NTSC disc.

HI-TEMP

(Monitor display)

HI TEMP

(Audio display)

- Protective circuit is activated to high temperature.
 - The indicator will disappear when the temperature returns to within operation range.
 - Leave the power OFF until the temperature decreases and then turn the power ON again.

LOADING ERROR

ERROR

(Audio display)

EJECT ERROR

(Monitor display)

- Mechanism error.
 - 1) Press the **▲** button and eject the disc.
If not ejecting, consult your Alpine dealer.
 - 2) When the error indication remains after ejecting, press the **▲** button again.
If the error indication still does not turn off after pressing the **▲** button for a few times, consult your Alpine dealer.

DISC ERROR

(Monitor display)

- Scratched disc, contaminated disc/poor recording/disc incompatible with this unit
 - Press the ▲ button.
 - Change the disc.

ERROR

(Audio display)

ERROR

(Audio display)

- The temperature in the car is too low.
 - Raise the temperature in the car to normal temperature.

Indication for CD Changer**HI TEMP**

- Protective circuit is activated due to high temperature.
 - The indicator will disappear when the temperature returns to within operation range.

ERROR - 01

- Malfunction in the CD Changer.
 - Consult your Alpine dealer. Press the magazine eject button and pull out the magazine. Check the indication. Insert the magazine again. If the magazine cannot be pulled out, consult your Alpine dealer.
- Magazine ejection not possible.
 - Press the magazine eject button. If the magazine does not eject, consult your Alpine dealer.

ERROR - 02

- A disc is left inside the CD Changer.
 - Press the Eject button to activate the eject function. When the CD Changer finishes the eject function, insert an empty CD magazine into the CD Changer to receive the disc left inside the CD Changer.

NO MAGZINE

- No magazine is loaded into the CD Changer.
 - Insert a magazine.

NO DISC

- No indicated disc.
 - Choose another disc.

Indication for XM Radio Mode**ANTENNA**

- The XM antenna is not connected to the XM radio module.
 - Check whether the XM antenna cable is attached securely to the XM radio module.

UPDATING

- Radio is being updated with latest encryption code.
 - Wait until encryption code is being updated. Channels 0 and 1 should function normally.

NO SIGNAL

- XM signal is too weak at the current location.
 - Wait until the car reaches a location with a stronger signal.

LOADING

- Radio is acquiring audio or program information.
 - Wait until the radio has received the information.

OFF AIR

- The channel currently selected has stopped broadcasting.
 - Select another channel.

- The user has selected a Channel Number that does not exist or is not subscribed to.
 - The unit will revert back to the previously selected channel.
- There is no artist name/feature, song/program title, or additional information associated with the channel at that time.
 - No action needed.

Information

Specifications

FM TUNER SECTION

Tuning Range	87.7 – 107.9 MHz
Mono Usable Sensitivity	9.3 dBf (0.8 μ V/75 ohms)
50 dB Quieting Sensitivity	13.5 dBf (1.3 μ V/75 ohms)
Alternate Channel Selectivity	80 dB
Signal-to-Noise Ratio	80 dB
Stereo Separation	45 dB
Capture Ratio	2.0 dB

AM TUNER SECTION

Tuning Range	530 – 1,710 kHz
Sensitivity (IEC Standard)	22.5 μ V/27 dB

CD/DVD SECTION

Frequency Response	5 – 20,000 Hz
Wow & Flutter (% WRMS)	Below measurable limits
Total Harmonic Distortion	0.008% (at 1 kHz)
Dynamic Range	95 dB (at 1 kHz)
Channel Separation	90 dB (at 1 kHz)
Signal system	NTSC
Horizontal resolution	500 lines or greater
Video output level	1Vp-p (75 ohms)
Video S/N ratio	DVD: 70 dB
Audio S/N ratio	More than 115 dB

PICKUP

Wave length	655 nm
Laser power	CLASS II

REMOTE CONTROL

Battery Type	AAA batteries (2 pcs.)
Width	56 mm (2-1/4")
Height	142.5 mm (5-5/8")
Depth	37 mm (1-7/16")
Weight	72 g (2.54 oz)

GENERAL

Power Requirement	14.4 V DC (11–16 V allowable)
Maximum Pre-Output Voltage	5 V/10 k ohms
Bass	\pm 14 dB at 60 Hz
Treble	\pm 14 dB at 10 kHz
Weight	2.0 kg (4 lbs. 7 oz)
Audio output level	
Preout (Front, Rear):	5V/10k ohms (max.)
Preout (Subwoofer):	4V/10k ohms (max.)
Auxout:	1.2V/10k ohms
Ai-NET:	850 mV

CHASSIS SIZE

Width	178 mm (7")
Height	50 mm (2")
Depth	155 mm (6-1/8")

NOSEPIECE SIZE

Width	170 mm (6-11/16")
Height	46 mm (1-13/16")
Depth	18 mm (11/16")

Due to continuous product improvement, specifications and design are subject to change without notice.

CAUTION

CAUTION-Laser radiation when open, DO NOT STARE INTO BEAM

(Bottom side of player)

Installation and Connections

Before installing or connecting the unit, please read the following and pages 3 and 4 of this manual thoroughly for proper use.

Warning

MAKE THE CORRECT CONNECTIONS.

Failure to make the proper connections may result in fire or product damage.

USE ONLY IN CARS WITH A 12 VOLT NEGATIVE GROUND.

(Check with your dealer if you are not sure.) Failure to do so may result in fire, etc.

BEFORE WIRING, DISCONNECT THE CABLE FROM THE NEGATIVE BATTERY TERMINAL.

Failure to do so may result in electric shock or injury due to electrical shorts.

DO NOT ALLOW CABLES TO BECOME ENTANGLED IN SURROUNDING OBJECTS.

Arrange wiring and cables in compliance with the manual to prevent obstructions when driving. Cables or wiring that obstruct or hang up on places such as the steering wheel, gear lever, brake pedals, etc. can be extremely hazardous.

DO NOT SPLICE INTO ELECTRICAL CABLES.

Never cut away cable insulation to supply power to other equipment. Doing so will exceed the current carrying capacity of the wire and result in fire or electric shock.

DO NOT DAMAGE PIPE OR WIRING WHEN DRILLING HOLES.

When drilling holes in the chassis for installation, take precautions so as not to contact, damage or obstruct pipes, fuel lines, tanks or electrical wiring. Failure to take such precautions may result in fire.

DO NOT USE BOLTS OR NUTS IN THE BRAKE OR STEERING SYSTEMS TO MAKE GROUND CONNECTIONS.

Bolts or nuts used for the brake or steering systems (or any other safety-related system), or tanks should NEVER be used for installations or ground connections. Using such parts could disable control of the vehicle and cause fire etc.

KEEP SMALL OBJECTS SUCH AS BATTERIES OUT OF THE REACH OF CHILDREN.

Swallowing them may result in serious injury. If swallowed, consult a physician immediately.

DO NOT INSTALL IN LOCATIONS WHICH MIGHT HINDER VEHICLE OPERATION, SUCH AS THE STEERING WHEEL OR GEARSHIFT.

Doing so may obstruct forward vision or hamper movement etc. and results in serious accident.

Caution

HAVE THE WIRING AND INSTALLATION DONE BY EXPERTS.

The wiring and installation of this unit requires special technical skill and experience. To ensure safety, always contact the dealer where you purchased this product to have the work done.

USE SPECIFIED ACCESSORY PARTS AND INSTALL THEM SECURELY.

Be sure to use only the specified accessory parts. Use of other than designated parts may damage this unit internally or may not securely install the unit in place. This may cause parts to become loose resulting in hazards or product failure.

ARRANGE THE WIRING SO IT IS NOT CRIMPED OR PINCHED BY A SHARP METAL EDGE.

Route the cables and wiring away from moving parts (like the seat rails) or sharp or pointed edges. This will prevent crimping and damage to the wiring. If wiring passes through a hole in metal, use a rubber grommet to prevent the wire's insulation from being cut by the metal edge of the hole.

DO NOT INSTALL IN LOCATIONS WITH HIGH MOISTURE OR DUST.

Avoid installing the unit in locations with high incidence of moisture or dust. Moisture or dust that penetrates into this unit may result in product failure.

Precautions

- Be sure to disconnect the cable from the (-) battery post before installing your DVA-7996. This will reduce any chance of damage to the unit in case of a short-circuit.
- Be sure to connect the color coded leads according to the diagram. Incorrect connections may cause the unit to malfunction or damage to the vehicle's electrical system.
- When making connections to the vehicle's electrical system, be aware of the factory installed components (e.g. on-board computer). Do not tap into these leads to provide power for this unit. When connecting the DVA-7996 to the fuse box, make sure the fuse for the intended circuit of the DVA-7996 has the appropriate amperage. Failure to do so may result in damage to the unit and/or the vehicle. When in doubt, consult your ALPINE dealer.
- The DVA-7996 uses female RCA-type jacks for connection to other units (e.g. amplifier) having RCA connectors. You may need an adaptor to connect other units. If so, please contact your authorized ALPINE dealer for assistance.

IMPORTANT

Please record the serial number of your unit in the space provided below and keep it as a permanent record. The serial number plate is located on the bottom of the unit.

SERIAL NUMBER: _____
INSTALLATION DATE: _____
INSTALLATION TECHNICIAN: _____
PLACE OF PURCHASE: _____

Installation and Connections

Installation

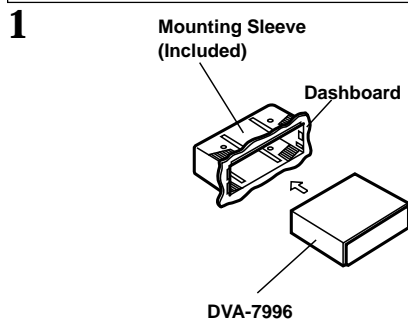
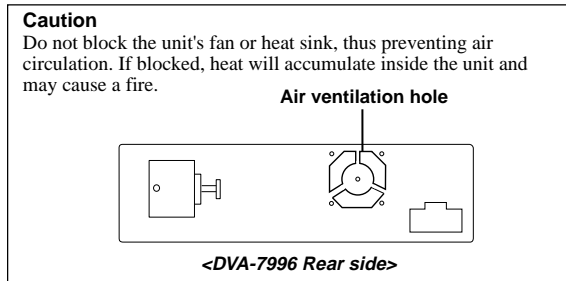
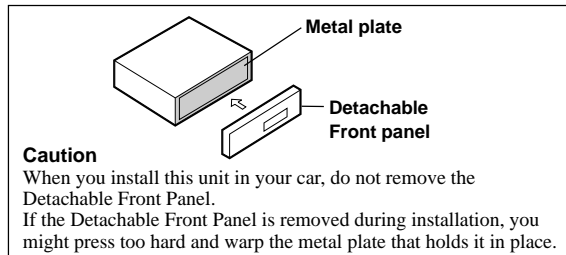

Slide the mounting sleeve into the dashboard.

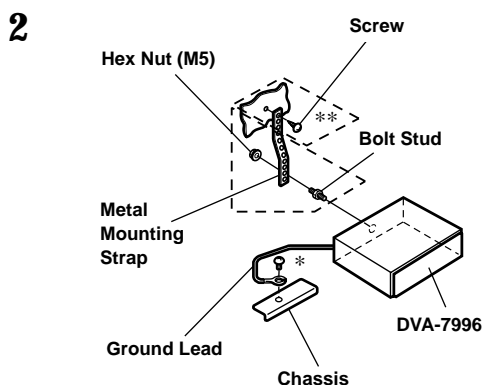

Reinforce the head unit with the metal mounting strap (not supplied). Secure the ground lead of the unit to a clean metal spot using a screw (*) already attached to the vehicle's chassis.

NOTE

For the screw marked **, use an appropriate screw for the chosen mounting location.

Connect each input lead coming from an amplifier or equalizer to the corresponding output lead coming from the left rear of the DVA-7996. Connect all other leads of the DVA-7996 according to details described in the CONNECTIONS section.

3

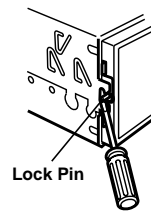

Slide the DVA-7996 into the dashboard. When the unit is in place, make sure the locking pins are fully seated in the down position. This can be done by pressing firmly in on the unit while pushing the locking pin down with a small screwdriver. This ensures that the unit is properly locked and will not accidentally come out from the dashboard. Install the Detachable Front Panel.

Removal

- 1 Remove the DETACHABLE FRONT PANEL.
- 2 Use a small screwdriver (or similar tool) to push the locking pins to the "up" position (see above drawing). As each pin is unlocked, gently pull out on the unit to make sure it does not re-lock before unlocking the second pin.
- 3 Pull the unit out, keeping it unlocked as you do so.

<JAPANESE CAR>

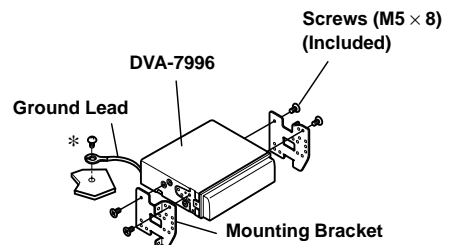
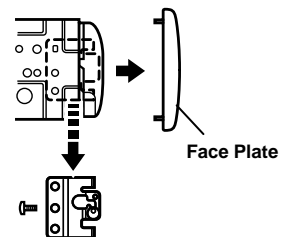

NOTE

Secure the ground lead of the unit to a clean metal spot using a screw (*) already attached to the vehicle's chassis.

● Mounting the remote control holder

- If the remote control is in direct sunlight, remove it from the holder and keep it in the glove box.
- When the holder cannot be mounted securely with Velcro tape, mount it by using screws.

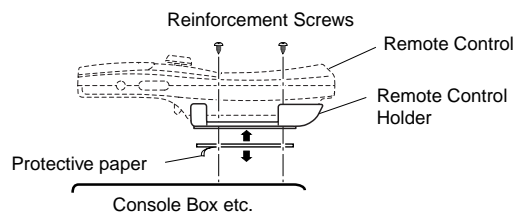

Connections

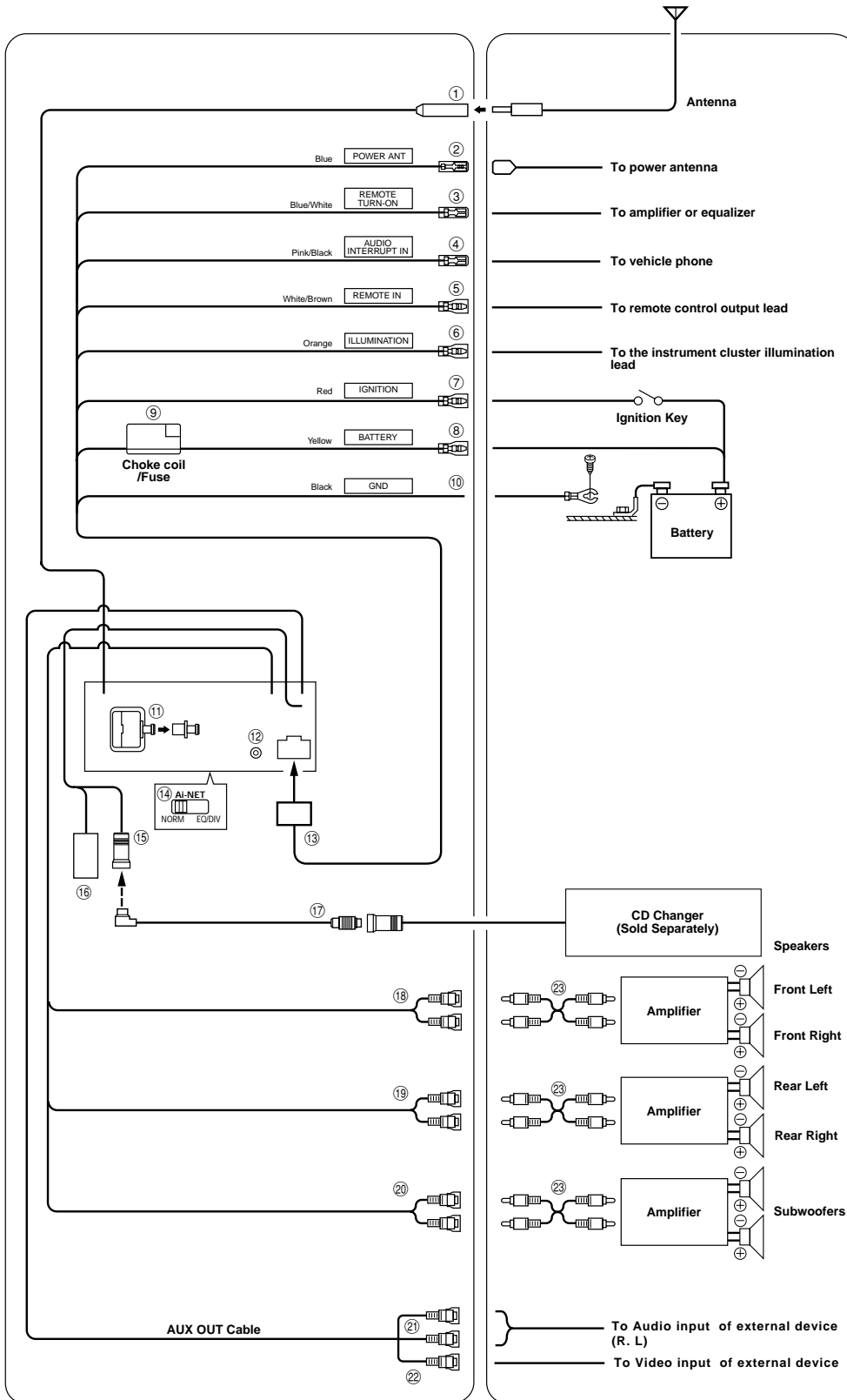

Installation and Connections

- ① **Antenna Receptacle**
- ② **Power Antenna Lead (Blue)**
Connect this lead to the +B terminal of your power antenna, if applicable.
NOTE
This lead should be used only for controlling the vehicle's power antenna. Do not use this lead to turn on an amplifier or a signal processor, etc.
- ③ **Remote Turn-On Lead (Blue/White)**
Connect this lead to the remote turn-on lead of your amplifier or signal processor.
- ④ **Audio Interrupt In Lead (Pink/Black)**
- ⑤ **Remote Control Input Lead (White/Brown)**
Connect the external Alpine product to the remote control output lead.
- ⑥ **Illumination Lead (Orange)**
This lead may be connected to the vehicle's instrument cluster illumination lead. This will allow the backlighting of the DVA-7996 to dim whenever the vehicle's lights are turned on.
- ⑦ **Switched Power Lead (Ignition) (Red)**
Connect this lead to an open terminal on the vehicle's fuse box or another unused power source which provides (+)12V only when the ignition is turned on or in the accessory position.
- ⑧ **Battery Lead (Yellow)**
Connect this lead to the positive (+) post of the vehicle's battery.
- ⑨ **Fuse Holder**
7.5A
- ⑩ **Ground Lead (Black)**
Connect this lead to a good chassis ground on the vehicle. Make sure the connection is made to bare metal and is securely fastened using the sheet metal screw provided.
- ⑪ **Digital Output Terminal (Optical)**
Use when combining fiber digital input compatible products.
- ⑫ **External Remote**
Use when applying the separately sold remote control sensor unit.
- ⑬ **Power Supply Connector**
- ⑭ **System Switch**
When connecting a processor or divider using Ai-NET, place this switch in the EQ/DIV position. When no device is connected, leave the switch in the NORM position.
NOTE
Be sure to turn the power off to the unit before changing the switch position.
- ⑮ **Ai-NET Connector**
Connect this to the output or input connector of other product (CD Changer, Equalizer, etc.) equipped with Ai-NET.
NOTE
You can input TV/video sound by connecting an optional Ai-NET/RCA Interface cable (KCA-121B) to this component.
- ⑯ **DC/DC Converter**
NOTES
 - Do not install the converter at a location subjected to water such as under the floor mat or air conditioner. This may cause a malfunction.
 - Do not bundle the DC/DC converter cable with other audio cables. Doing so may induce noise into your system.
 - Keep the DC/DC converter away from the Antenna cables and the rear side of the unit, otherwise noise may be generated when receiving radio broadcast.
- ⑰ **Ai-NET Cable (Included with CD Changer)**
- ⑱ **Front Output RCA Connectors**
RED is right and WHITE is left.
- ⑲ **Rear Output RCA Connectors**
RED is right and WHITE is left.
- ⑳ **Subwoofer RCA Connectors**
RED is right and WHITE is left.
- ㉑ **Audio Output Connectors**
RED is right and WHITE is left. Output the audio.
- ㉒ **Video Output Connectors (Yellow)**
Output the video.
- ㉓ **RCA Extension Cable (Sold Separately)**

To prevent external noise from entering the audio system.

- Locate the unit and route the leads at least 10 cm away from the car harness.
- Keep the battery power leads as far away from other leads as possible.
- Connect the ground lead securely to a bare metal spot (remove any paint, dirt or grease if necessary) of the car chassis.
- If you add an optional noise suppressor, connect it as far away from the unit as possible. Your Alpine dealer carries various noise suppressors, contact them for further information.
- Your Alpine dealer knows best about noise prevention measures so consult your dealer for further information.

System Example

- Connect the Ai-NET compatible equalizer and the changer

System switch | **EQ/DIV**



Set the system switch to "NORM" when only a changer is connected (when the Ai-NET compatible equalizer is not used).

In this case, tone control operations can only be performed on the equalizer. (Tone bypass function) **

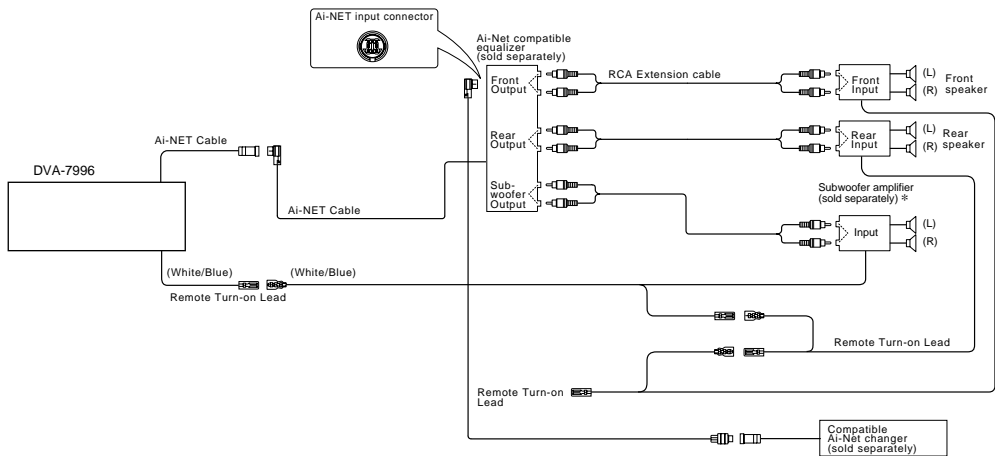

- * An amplifier with a built-in low pass filter is required.
- ** Tone bypass function: With this function, the tone is adjusted using the equalizer's tone control circuit (without using the head unit's tone control circuit).

- Connect the Ai-NET compatible audio processor (Fiber digital compatible) and TV monitor/changer

System switch | **EQ/DIV**

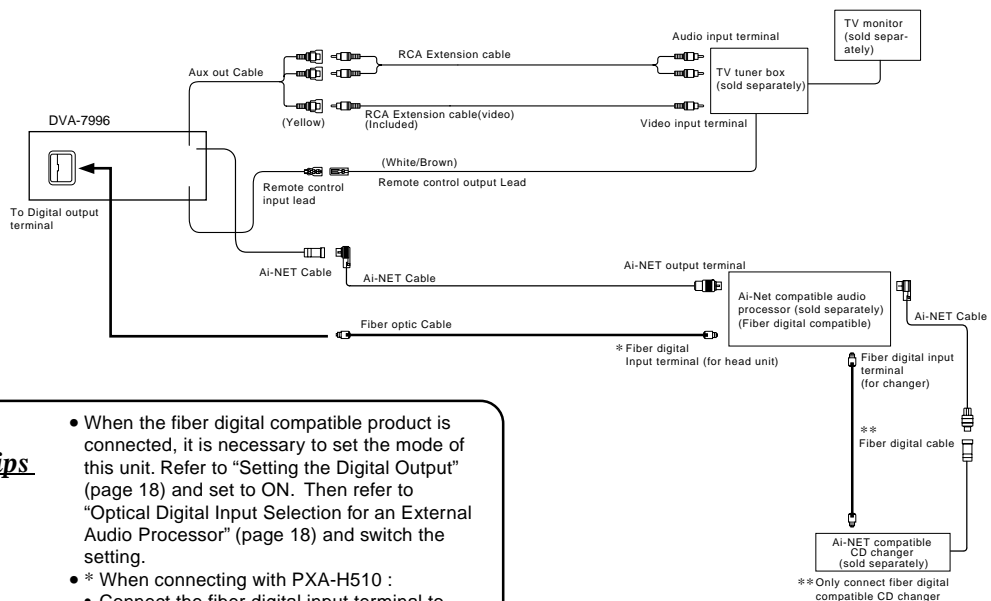

- When the fiber digital compatible product is connected, it is necessary to set the mode of this unit. Refer to "Setting the Digital Output" (page 18) and set to ON. Then refer to "Optical Digital Input Selection for an External Audio Processor" (page 18) and switch the setting.
- * When connecting with PXA-H510 :
 - Connect the fiber digital input terminal to the DVD.
 - DVA-7996, DVA-5200 or DVA-5205 cannot be connected simultaneously when fiber digital is in use.

** Only connect fiber digital compatible CD changer

GARANTIE LIMITÉE

Fidèles à leur engagement de ne fournir que des produits de qualité, ALPINE ELECTRONIQUE DE L'AMERIQUE INC. et ALPINE ELECTRONIQUE DU CANADA INC. (Alpine) sont heureuses de vous offrir cette garantie. Nous vous suggérons de le lire attentivement et en entier. Si vous avez la moindre question, veuillez contacter l'un de nos concessionnaires ou appeler directement Alpine au numéros Liste ci-dessous.

● PRODUITS COUVERT PAR LA GARANTIE

Cette garantie couvre les produits audio/visuel de voiture et les accessoires connexes ("le produit"). Elle ne couvre les produits que dans le pays où il ont été achetés.

● DURÉE DE LA GARANTIE

Cette garantie est en vigueur pendant un an à partir de la date du premier achat du client.

● GARANTIE À VIE DES TÊTES DE LECTURE DES MAGNÉTOPHONES À CASSETTES

Toutes les têtes de cassettes analogiques audio de voiture Alpine, à l'exception des têtes de cassettes vidéo sont garanties à vie contre des vices de fabrication pouvant entraîner leur panne.

● PERSONNES PROTÉGÉES PAR LA GARANTIE

Seul l'acheteur original du produit, s'il réside aux États-Unis, à Porto Rico ou au Canada, peut se prévaloir de la garantie.

● CE QUI EST COUVERT

Cette garantie couvre tous les défauts de matériaux et de fabrication (pièces et main d'œuvre) du produit.

● CE QUI N'EST PAS COUVERT

Cette garantie ne couvre pas ce qui suit:

- ① Les dommages survenus durant le transport des produits renvoyés à Alpine pour être réparés (les réclamations doivent être adressées au transporteur);
- ② Tout dégât provoqué par accident, abus, négligence, usage inapproprié, mauvais raccordement, mauvaise utilisation ou par le non-respect des instructions indiquées dans le manuel de l'utilisateur.
- ③ Les dommages dus à la force majeure, notamment aux tremblements de terre, au feu, aux inondations, aux tempêtes ou aux autres cataclysmes naturels;
- ④ Les frais ou les dépenses relatifs à l'enlèvement ou à la réinstallation du produit;
- ⑤ Les services rendus par une personne, physique ou morale non autorisée;
- ⑥ Les produits dont le numéro de série a été effacé, modifié ou retiré;
- ⑦ Les produits qui ont été adaptés ou modifiés sans le consentement d'Alpine;
- ⑧ Les produits qui ne sont pas distribués par Alpine aux États-Unis, à Porto Rico ou au Canada;
- ⑨ Les produits qui n'ont pas été achetés par l'entremise d'un concessionnaire Alpine autorisé;
- ⑩ Tout produit qui a été déterminé comme contenant une quantité excessive de poussière ou de saleté et tout produit qui contient d'autres saleté, en ce compris du liquide et des corps étrangers.

● COMMENT SE PRÉVALOIR DE LA GARANTIE

- ① Il vous faut remettre le produit nécessitant des réparations à un centre de service autorisé Alpine ou à Alpine même et en assumer les frais de transport. Alpine a le choix entre réparer le produit ou le remplacer par un produit neuf ou révisé, le tout sans frais pour vous. Si les réparations sont couvertes par la garantie et si le produit a été envoyé à un centre de service Alpine ou à Alpine, le paiement des frais de réexpédition du produit incombe Alpine.

- ② Vous devez donner une description détaillée des problèmes qui sont à l'origine de votre demande de réparation.
- ③ Vous devez joindre la preuve de votre achat du produit.
- ④ Vous devez emballer soigneusement le produit pour éviter tout dommage durant son transport.

● LIMITATION DES GARANTIES TACITES

LA DURÉE DE TOUTES LES GARANTIES TACITES, Y COMPRIS LA GARANTIE D'ADAPTATION A L'UTILISATION ET LA GARANTIE DE QUALITÉ LOYALE ET MARCHANDE, EST LIMITÉE À CELLE DE LA GARANTIE EXPRESSE DÉTERMINÉE CI-DESSUS. PERSONNE N'EST AUTORISÉ À ENGAGER AUTREMENT LA RESPONSABILITÉ D'ALPINE EN VERTU DE LA VENTE D'UN PRODUIT.

● EXCLUSIONS DE LA GARANTIE

ALPINE STIPULE EXPRESSÉMENT QU'ELLE N'EST PAS RESPONSABLE DES DOMMAGES DOMMAGES-INTÉRÊTS ET DOMMAGES INDIRECTS PROVOQUÉS PAR LE PRODUIT. LES DOMMAGES DOMMAGES-INTÉRÊTS SONT LES FRAIS DE TRANSPORT DU PRODUIT VERS UN CENTRE DE SERVICE ALPINE, LA PERTE DE TEMPS DE L'ACHETEUR ORIGINAL, LA PERTE D'UTILISATION DU PRODUIT, LES BILLETS D'AUTOBUS, LA LOCATION DE VOITURES ET TOUS LES AUTRES FRAIS LIÉS À LA GARDE DU PRODUIT.

LES DOMMAGES INDIRECTS SONT LES FRAIS DE RÉPARATION OU DE REMPLACEMENT D'AUTRES BIENS ENDOMMAGÉS SUITE AU MAUVAIS FONCTIONNEMENT DU PRODUIT.

LES RECOURS PRÉVUS PAR LES PRÉSENTES EXCLUENT ET REMPLACENT TOUTE AUTRE FORME DE RECOURS.

● LIEN ENTRE LA GARANTIE ET LA LOI

La garantie vous donne des droits spécifiques, mais vous pouvez aussi jouir d'autres droits, qui varient d'un état ou d'une province à l'autre. En outre, certains états et certaines provinces interdisent de limiter la durée des garanties tacites ou d'exclure les dommages accessoires ou indirects. Dans ce cas, les limites et les exclusions de la garantie peuvent ne pas s'appliquer à vous.

● CLAUSE APPLICABLE AU CANADA SEULEMENT

Pour que la garantie soit valable, il faut qu'un centre d'installation autorisé ait installé le système audio pour l'auto dans votre véhicule et qu'il ait ensuite apposé son cachet sur la garantie.

● NUMÉROS D'APPEL DU SERVICE À LA CLIENTELE

Si vous avez besoin de nos services, veuillez appeler le centre de service autorisé Alpine le plus proche.

U.S.A.	1-800-ALPINE-1 (1-800-257-4631)
CANADA	1-800-ALPINE-1 (1-800-257-4631)

LIMITED WARRANTY

ALPINE ELECTRONICS OF AMERICA, INC. AND ALPINE OF CANADA INC. ("Alpine"), are dedicated to quality craftsmanship and are pleased to offer this Warranty. We suggest that you read it thoroughly. Should you have any questions, please contact your Dealer or Alpine at one of the telephone numbers listed below.

● PRODUCTS COVERED:

This Warranty covers Car Audio/Visual Products and Related Accessories ("the product"). Products purchased in the Canada are covered only in the Canada. Products purchased in the U.S.A. are covered only in the U.S.A.

● LENGTH OF WARRANTY:

This Warranty is in effect for one year from the date of the first consumer purchase.

● LIFETIME TAPE HEAD WARRANTY:

All Alpine Car Audio analog tape heads excluding Video tape heads are warranted for life against manufacturing defects causing failure.

● WHO IS COVERED:

This Warranty only covers the original purchaser of the product, who must reside in the United States, Puerto Rico or Canada.

● WHAT IS COVERED:

This Warranty covers defects in materials or workmanship (parts and labor) in the product.

● WHAT IS NOT COVERED:

This Warranty does not cover the following:

- ① Damage occurring during shipment of the product to Alpine for repair (claims must be presented to the carrier).
- ② Damage caused by accident, abuse, negligence, misuse, improper connections, improper operation or failure to follow instructions contained in the Owner's manual.
- ③ Damage caused by act of God, including without limitation, earthquake, fire, flood, storms or other acts of nature.
- ④ Any cost or expense related to the removal or reinstallation of the product.
- ⑤ Service performed by an unauthorized person, company or association.
- ⑥ Any product which has the serial number defaced, altered or removed.
- ⑦ Any product which has been adjusted, altered or modified without Alpine's consent.
- ⑧ Any product not distributed by Alpine within the United States, Puerto Rico or Canada.
- ⑨ Any product not purchased from an Authorized Alpine Dealer.
- ⑩ Any product that has been determined to contain an excessive amount of dust or dirt and any product that contains other contaminants including liquid or foreign objects.

● HOW TO OBTAIN WARRANTY SERVICE:

- ① You are responsible for delivery of the product to an Authorized Alpine Service Center or Alpine for repair and for payment of any initial shipping charges. Alpine will, at its option, repair or replace the product with a new or reconditioned product without charge. If the repairs are covered by the warranty, and if the product was shipped to an Authorized Alpine Service Center or Alpine, Alpine will pay the return shipping charges.

- ② You should provide a detailed description of the problem(s) for which service is required.
- ③ You must supply proof of your purchase of the product.
- ④ You must package the product securely to avoid damage during shipment.

● HOW WE LIMIT IMPLIED WARRANTIES:

ANY IMPLIED WARRANTIES INCLUDING FITNESS FOR USE AND MERCHANTABILITY ARE LIMITED IN DURATION TO THE PERIOD OF THE EXPRESS WARRANTY SET FORTH ABOVE AND NO PERSON IS AUTHORIZED TO ASSUME FOR ALPINE ANY OTHER LIABILITY IN CONNECTION WITH THE SALE OF THE PRODUCT.

● HOW WE EXCLUDE CERTAIN DAMAGES:

ALPINE EXPRESSLY DISCLAIMS LIABILITY FOR INCIDENTAL AND CONSEQUENTIAL DAMAGES CAUSED BY THE PRODUCT. THE TERM "INCIDENTAL DAMAGES" REFERS TO EXPENSES OF TRANSPORTING THE PRODUCT TO THE ALPINE SERVICE CENTER, LOSS OF THE ORIGINAL PURCHASER'S TIME, LOSS OF THE USE OF THE PRODUCT, BUS FARES, CAR RENTALS OR OTHER COSTS RELATING TO THE CARE AND CUSTODY OF THE PRODUCT. THE TERM "CONSEQUENTIAL DAMAGES" REFERS TO THE COST OF REPAIRING OR REPLACING OTHER PROPERTY WHICH IS DAMAGED WHEN THIS PRODUCT DOES NOT WORK PROPERLY. THE REMEDIES PROVIDED UNDER THIS WARRANTY ARE EXCLUSIVE AND IN LIEU OF ALL OTHERS.

● HOW STATE/PROVINCIAL LAW RELATES TO THE WARRANTY:

This Warranty gives you specific legal rights, and you may also have other rights which vary from state to state and province to province. In addition, some states/provinces do not allow limitations on how long an implied warranty lasts, and some do not allow the exclusion or limitation of incidental or consequential damages. Accordingly, limitations as to these matters contained herein may not apply to you.

● IN CANADA ONLY:

This Warranty is not valid unless your Alpine car audio product has been installed in your vehicle by an Authorized Installation Center, and this warranty stamped upon installation by the installation center.

● HOW TO CONTACT CUSTOMER SERVICE:

Should the product require service, please call the following number for your nearest Authorized Alpine Service Center.

U.S.A.	1-800-ALPINE-1 (1-800-257-4631)
CANADA	1-800-ALPINE-1 (1-800-257-4631)

CORRECTION/CORRECTION/CORRECCIÓN



The Owner's Manual has errors as shown here./Le mode d'emploi contient les erreurs indiquées ici./El manual de operación contiene los errores mostrados aquí.

English

- Page 25 "**About MP3**", **Supported playback sampling rates**

<Incorrect>

Sampling rates: 16 kHz - 48 kHz

- Page 39 "**Changing the down sampling setting**", step 3

<Incorrect>

OFF

The digital signals recorded on the DVD disc with 96 kHz/24bit, 96 kHz/20bit, 96 kHz/16bit, 48 kHz/24bit, 48 kHz/20bit sampling are not converted into digital signals with 48 kHz/16bits sampling. There is no output from the optical output.

<Correct>

Sampling rates: 32kHz - 48 kHz

<Correct>

OFF

Digital signals sampled at 96kHz/24 bit, 96kHz/20 bit or 96kHz/16 bit and recorded on the DVD cannot be converted to 48 kHz/16 bit sampled digital signal. There is no output from the optical digital output terminal. However, when CSS* scramble is on, a digital signal sampled at 48kHz/16 bit can be converted and sent out through the optical digital output.

* CSS : An acronym for digital copy encryption protection (Content Scrambling System)

- Page 41, a part of "**Audio output/Optical digital audio output**" has been corrected, as shown below.

Disc	Audio recording format	Digital output setting	Down sampling setting	Optical digital audio output (when a digital audio processor is connected)	Analog audio output (Ai-NET, RCA output)	
DVD	Linear PCM	48kHz/20bit	AUTO	OFF	LPCM (48kHz/16bit)	OK
		48kHz/24bit				
		96kHz/16bit	AUTO	OFF	When CSS scramble is on : LPCM (48kHz/16 bit) When CSS scramble is off : no output	OK
		96kHz/20bit	LPCM			
			AUTO			
			LPCM			
	96kHz/24bit	AUTO				
		LPCM				
CD	DTS	Download from Wwww.Somanuals.com	ON/OFF	LPCM Encode 2ch Down mix (44.1kHz/16bit)	OK	

The Owner's Manual has errors as shown here./Le mode d'emploi contient les erreurs indiquées ici./El manual de operación contiene los errores mostrados aquí.

English

- Page 58 "**Installation and Connections**"

<Incorrect>	<Correct>
⑨ Fuse Holder 7.5A	Fuse Holder 10A

Français

- Page 58 "**Installation et raccordements**"

<Incorrect>	<Correct>
⑨ Porte-fusible 7,5A	Porte-fusible 10A

Español

- Página 58 "**Instalación y conexiones**"

<Incorrecto>	<Correcto>
⑨ Portafusibles 7,5A	Portafusibles 10A

English

This unit has a built-in DTS 2-channel audio decoder. Analog audio outputs are available.

Français

Cet appareil est équipé d'un décodeur audio 2 canaux DTS intégré, ainsi que de sorties audio analogiques.

Español

Esta unidad dispone de un decodificador de audio de 2 canales DTS incorporado. También hay disponibles salidas de audio analógico.

Deutsch

Dieses Gerät ist mit einem eingebauten DTS-2-Kanal-Audiodecoder ausgestattet. Darüber hinaus verfügt es auch über analoge Audioausgänge.

Italiano

Il presente apparecchio è dotato di un decodificatore audio a 2 canali DTS incorporato. Sono inoltre disponibili uscite audio analogiche.

Svenska

Den här enheten har en inbyggd DTS 2-kanalig ljudavkodare. Analoga ljudutgångar finns tillgängliga.

RUE-4190 TV/MONI. MODE CONTROL

Please confirm your system.

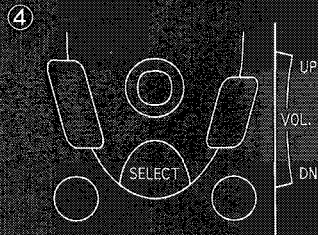
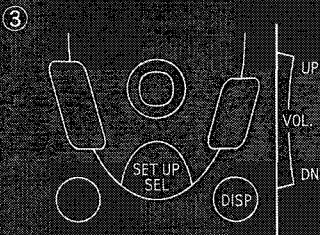
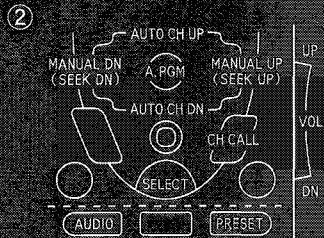
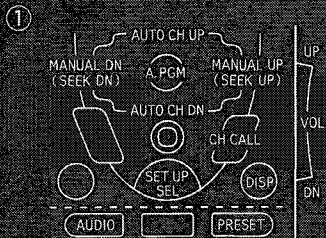

Your case

MONITOR	TV Tuner	Label type
TME-M580/M760	TCS-V430A	①
TME-M750	TCS-V430A	②
TME-M580/M760	TUE-T011	※③
TME-M750	TUE-T011	※④
TME-M580/M760	NONE	③
TME-M750	NONE	④

※ Impossible to control this TV Tuner

Put this label on bottom of the remote controller unit.

**Business
Replay Mail**

No Postage Stamp
Necessary If Mailed
In Canada

Postage will be paid by



ALPINE ELECTRONICS OF CANADA, INC.
Suite 203, 7300 Warden Ave. Markham,
Ontario L3R 9Z6

↑ FOR USE IN CANADA, PLEASE FOLD HERE AND ENSURE THAT
CANADIAN ADDRESS FACES UP.



NO POSTAGE
NECESSARY
IF MAILED
IN THE
UNITED STATES

BUSINESS REPLY MAIL

FIRST CLASS MAIL PERMIT N. 320 TORRANCE, CA.90509

POSTAGE WILL BE PAID BY ADDRESSEE



ALPINE ELECTRONICS OF AMERICA, INC.
Attention : MARKETING SERVICES
P.O. Box 2859
Torrance, CA 90509-9939



↑ FOR USE IN USA, PLEASE FOLD HERE AND ENSURE THAT
AMERICAN ADDRESS FACES UP.

er your product with us so we can serve you better.

Product purchased

- | | |
|---|--|
| 1. <input type="checkbox"/> Cassette Player | 9. <input type="checkbox"/> Monitor Controller |
| 2. <input type="checkbox"/> CD Player | 10. <input type="checkbox"/> Video Monitor |
| 3. <input type="checkbox"/> MD Player | 11. <input type="checkbox"/> Navigation |
| 4. <input type="checkbox"/> DVD Player | 12. <input type="checkbox"/> Mobile Mayday |
| 5. <input type="checkbox"/> CD Changer | 13. <input type="checkbox"/> Video Tape Player |
| 6. <input type="checkbox"/> Amplifier | 14. <input type="checkbox"/> Processor/Equalizer |
| 7. <input type="checkbox"/> Speaker | 15. <input type="checkbox"/> Security |
| 8. <input type="checkbox"/> Subwoofer | 16. <input type="checkbox"/> Other _____ |

Model Number: _____

Date of Purchase:

Month: _____ Year: _____

If navigation system, which monitor?

1. Alpine → (Model No.) _____
2. Other → (Brand Name) _____

Purpose of buying this unit?

1. Addition
2. Replacement → *Previous brand replaced?
- | |
|---|
| 1. <input type="checkbox"/> Factory installed |
| 2. <input type="checkbox"/> Alpine |
| 3. <input type="checkbox"/> Other _____ |

Have you purchased Alpine products before?

1. First time 2. Two or more times

When you purchased this Alpine unit, did you compare it with other brands?

1. Yes 2. No

(Brand Name) _____

Which of the following statements best describes you?

1. I usually have more electronic equipment than my friends
2. I am usually one of the first of my friends to buy the newest electronic equipment
3. I usually wait until a product has been out for a while before I purchase it
4. I am usually on of the first of my friends to know about the newest car
5. I usually know more about cars than my friends

Occupation

- | | |
|--|---|
| 1. <input type="checkbox"/> Executive/Managerial | 6. <input type="checkbox"/> Engineering/Technical |
| 2. <input type="checkbox"/> Secretarial/Clerical | 7. <input type="checkbox"/> Farming/Fishing |
| 3. <input type="checkbox"/> Sales | 8. <input type="checkbox"/> Retired |
| 4. <input type="checkbox"/> General Labor | 9. <input type="checkbox"/> Student |
| 5. <input type="checkbox"/> Professional | 10. <input type="checkbox"/> Other _____ |

Household Income

- | | |
|---|--|
| 1. <input type="checkbox"/> Less than \$30,000 | 4. <input type="checkbox"/> \$70,000 - \$90,000 |
| 2. <input type="checkbox"/> \$30,000 - \$50,000 | 5. <input type="checkbox"/> \$90,000 - \$110,000 |
| 3. <input type="checkbox"/> \$50,000 - \$70,000 | 6. <input type="checkbox"/> Over \$110,000 |

Type of vehicle in which this unit is installed.

Make: _____ Model: _____

Purchased Year: _____ Model Year: _____

How was this vehicle purchased?

1. Bought 2. Leased

SEAL HERE

Thank you for choosing Alpine! Please register your product with us so we can serve you better.

First name: _____

Last name: _____

Home address: _____
Street address

City _____ State/Prov. _____ Zip Code _____

May we contact you at this address? 1. Yes 2. No

Phone number: () _____

May we contact you at this number? 1. Yes 2. No

E-mail Address: _____

May we contact you by e-mail? 1. Yes 2. No

Gender 1. Male 2. Female

Date of Birth Month: _____ Year: _____

Marital Status 1. Single 2. Married

Which ethnicity best describes yourself:

- 1. Caucasian
- 2. Hispanic
- 3. African-American
- 4. Asian
- 5. Other _____

Your highest level of education completed:

- 1. High School Student
- 2. High School Graduate
- 3. 2 Yr. Degree/Some College
- 4. Completed 4 Yr. College
- 5. Completed Graduate School

Product purchased

- 1. Cassette Player
- 2. CD Player
- 3. MD Player
- 4. DVD Player
- 5. CD Changer
- 6. Amplifier
- 7. Speaker
- 8. Subwoofer
- 9. Monitor Controller
- 10. Video Monitor
- 11. Navigation
- 12. Mobile Mayday
- 13. Video Tape Player
- 14. Processor/Equalizer
- 15. Security
- 16. Other _____

Model Number: _____

Date of Purchase:
Month: _____ Year: _____

If navigation system, which monitor?

- 1. Alpine → (Model No.) _____
- 2. Other → (Brand Name) _____

Purpose of buying this unit?

- 1. Addition
- 2. Replacement → *Previous brand replaced?
 - 1. Factory installed
 - 2. Alpine
 - 3. Other _____

Have you purchased Alpine products before?

- 1. First time
- 2. Two or more times

SEAL HERE

Free Manuals Download Website

<http://myh66.com>

<http://usermanuals.us>

<http://www.somanuals.com>

<http://www.4manuals.cc>

<http://www.manual-lib.com>

<http://www.404manual.com>

<http://www.luxmanual.com>

<http://aubethermostatmanual.com>

Golf course search by state

<http://golfingnear.com>

Email search by domain

<http://emailbydomain.com>

Auto manuals search

<http://auto.somanuals.com>

TV manuals search

<http://tv.somanuals.com>