

EIR102 Series Quick Start Guide

QUICK START GUIDE

Package Contents

- EIR102 Series Industrial Media Converter
- Quick Start Guide (One per shipment)
- Power Terminal Block (installed)
- Fiber Optic Dust Covers (installed on fiber optic models)

If any item is missing or damaged, contact B&B Electronics for a replacement

Front Panel

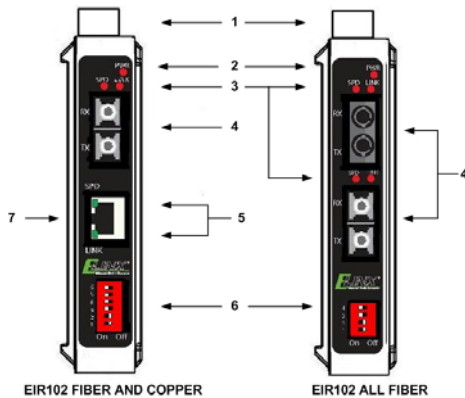

1	Power Terminal Block	2 Position, Removable
2	PWR LED	ON When Power Applied
3	Fiber Optic SPD LED	Normally OFF
3	Fiber Optic LINK LED	On When Fiber Port Linked
4	Fiber Optic Ports	No. & Type Depends on Model
5	RJ45 SPD LED	ON if 100 mbps
5	RJ45 LINK LED	ON When RJ45 Port Linked
		FLASHES When Data Transmitted
6	DIP Switch	4 POS for Fiber to Fiber 6 POS for Copper to Fiber
7	RJ45 Port	Depends on Model

DIN Rail Mounting

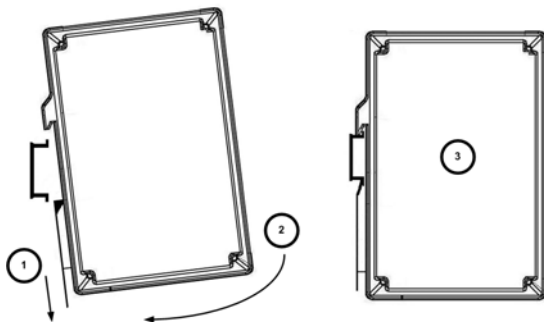

1. Slide and hold the DIN Clip toward the bottom of the Media Converter. Angle the top portion of the DIN mount over the top of the DIN rail.
2. Move the Media Converter so that it is parallel with the DIN Rail.
3. Release the DIN clip. The spring should return it to its original position.

Configure DIP Switch

1. Fiber to Copper models have a 6 position switch.
2. Fiber to Fiber models have a 4 position switch.
3. Switches are numbered from the bottom.
4. Cycle power after changing DIP Switch configuration.



Fiber and Copper Model



All Fiber Model

Switch	ON	OFF
1	Snooping (Store & Forward)	Snooping (Direct Pass-through)
2	Disable Link Fault Pass-through	Enable Link Fault Pass-through
3	Top Port Forced Half-duplex	Top Port Forced Full-duplex
4	Bottom Port Forced Half-duplex	Bottom Port Forced Full-duplex
5*	RJ45 Forced 10 mbps	RJ45 Forced 100 mbps
6*	RJ45 Forced Mode	**RJ45 Auto Negotiate Enabled

* Switch 5 and 6 are only on models with an RJ45 Port

** When RJ45 Auto Negotiate is Enabled, Switch 4 and 5 are ignored

Attach Power Leads External Supply Required



Warning: Work Safe – Equipment damage or electrical shock hazard exists. DO NOT ATTACH OR REMOVE LEADS WITH THE POWER SUPPLY ENERGIZED!

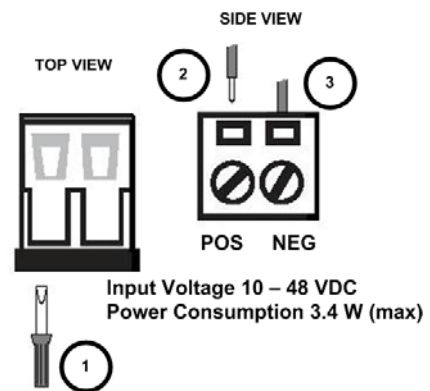

1. Loosen the screw to open the terminal block lead clamp.
2. Insert the power lead. TB will accept 12-28 AWG wire.
3. Tighten the screw to close the terminal block lead clamp. Ensure the clamp holds the lead securely. However, do not over tighten.

NOTE: For replacement Terminal Block order Part # 7444.

B&B electronics
 MANUFACTURING COMPANY

International Headquarters: 707 Dayton Road PO Box 1040 Ottawa, IL 61350 USA
 815-433-5100 Fax 433-5104 www.bb-elec.com orders@bb-elec.com support@bb-elec.com

European Headquarters: Westlink Commercial Park Oranmore Co. Galway Ireland
 +353 91 792444 Fax +353 91 792445 www.bb-europe.com orders@bb-europe.com support@bb-europe.com
 Download from www.Somanuals.com. All Manuals Search And Download.

B&B ELECTRONICS

Attach RJ45 Cable (If equipped)

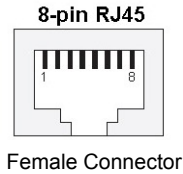

1. Auto MDI/MDI-x is supported. A straight through or cross-over cable may be used.
2. 10/100BaseT auto negotiation and full/half-duplex are supported. Speed and duplex can also be forced. Refer to DIP Switch settings.

Pin	Signal
1	Tx+
2	Tx-
3	Rx+
6	Rx-

Pin	Signal
1	Rx+
2	Rx-
3	Tx+
6	Tx-

Attach Fiber Optic Cable



Warning: Work Safe – This is a Class I Laser/LED device. To avoid causing serious damage to your eyes, DO NOT STARE DIRECTLY INTO THE LIGHT.

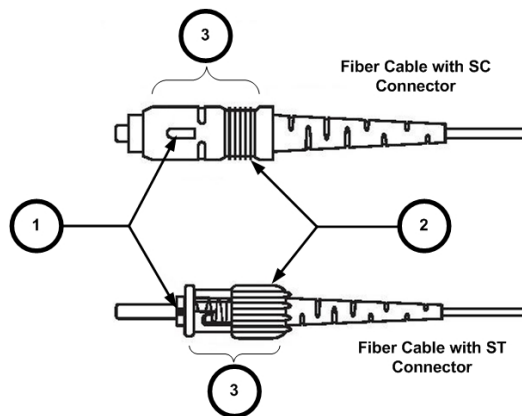

1. Ensure your fiber optic cable is terminated with the correct connector type. EIR102 Media Converters use SC or ST connectors.
2. Fiber optic type for each port is located on the product's side label. When connecting the cable to the media converter, be sure to line up the slider guide on the cable and media converter connectors.
3. Connect the fiber optic transmitter to the downstream device's receiver and vice-versa.

Fiber Optic Cable Information

Fiber Optic Cable Information		
Mode and Distance	Type	Wavelength
Multi-mode (2 km)	62.5/125 μ m	1310 nm
Single-mode (15 km)	9/125 μ m	1310 nm
Single-mode (40 km)	9/125 μ m	1310 nm
Single-mode (80 km)	9/125 μ m	1550 nm

	Output Power	RCVR Sensitivity
Multi-mode (2 km)	-19 to -14 dBm	\leq -32 dBm
Single-mode (15 km)	-15 to -8 dBm	\leq -32 dBm
Single-mode (40 km)	-5 to 0 dBm	\leq -34 dBm
Single-mode (80 km)	-5 to 0 dBm	\leq -34 dBm

Installation Complete

1. When the network cables are attached and power is applied, installation is complete.

NOTE: Recycle power if DIP Switch changes are made after power up.

Mechanical Diagram

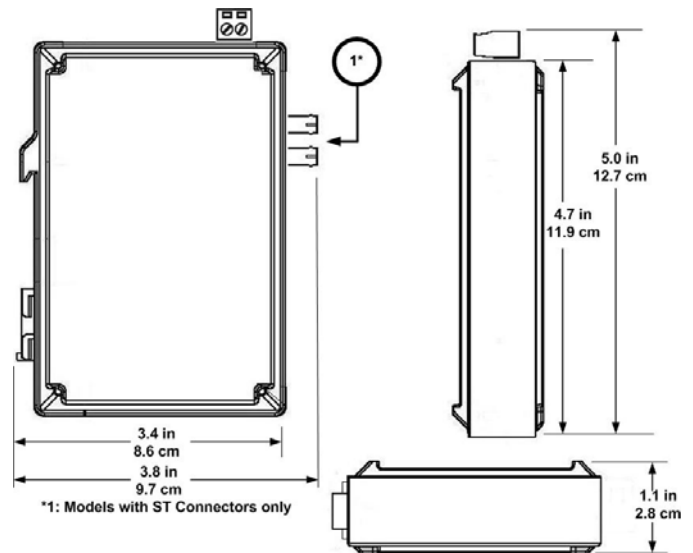

B&B electronics
MANUFACTURING COMPANY

International Headquarters: 707 Dayton Road PO Box 1040 Ottawa, IL 61350 USA
815-433-5100 Fax 433-5104 www.bb-elec.com orders@bb-elec.com support@bb-elec.com

European Headquarters: Westlink Commercial Park Oranmore Co. Galway Ireland
+353 91 792444 Fax +353 91 792445 www.bb-europe.com orders@bb-europe.com support@bb-europe.com
Download from www.SomaManuals.com. All Manuals Search And Download.

Free Manuals Download Website

<http://myh66.com>

<http://usermanuals.us>

<http://www.somanuals.com>

<http://www.4manuals.cc>

<http://www.manual-lib.com>

<http://www.404manual.com>

<http://www.luxmanual.com>

<http://aubethermostatmanual.com>

Golf course search by state

<http://golfingnear.com>

Email search by domain

<http://emailbydomain.com>

Auto manuals search

<http://auto.somanuals.com>

TV manuals search

<http://tv.somanuals.com>