



7214 MSL

Loader

Published 12/04

Part No. F-3778

OPERATOR'S MANUAL

This Operator's Manual is an integral part of the safe operation of this machine and must be maintained with the unit at all times. READ, UNDERSTAND, and FOLLOW the safety and Operation Instructions contained in this manual before operating the equipment.

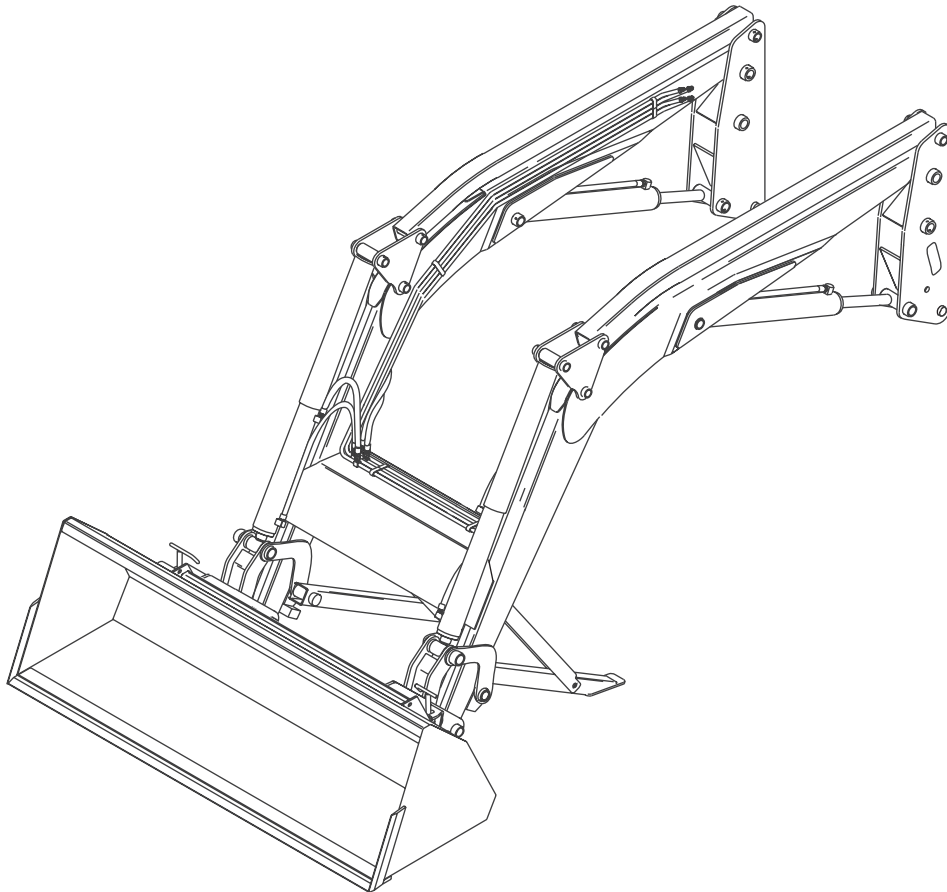

RHINO[®]

1020 S. Sangamon Ave.
Gibson City, IL, 60936
800-446-5158

Email: parts@servis-rhino.com

© 2004 Alamo Group, Inc.



TO THE OWNER/OPERATOR/DEALER

All implements with moving parts are potentially hazardous. There is no substitute for a cautious, safe-minded operator who recognizes the potential hazards and follows reasonable safety practices. The manufacturer has designed this implement to be used with all its safety equipment properly attached to minimize the chance of accidents.

BEFORE YOU START!! Read the safety messages on the implement and shown in your manual. Observe the rules of safety and common sense!

SAFETY HAZARD SIGNAL WORDS

There are three levels of hazard intensity identified by signal words DANGER, WARNING and CAUTION. The level of hazard intensity is identified by the following definitions.



DANGER - Immediate hazards which will result in severe injury or death.



WARNING - Hazards or unsafe practices which could result in minor personal injury or death.



CAUTION - Hazards or unsafe practices which could result in minor personal injury or property damage.



THIS SAFETY SYMBOL MEANS

ATTENTION!

BECOME ALERT!

YOUR SAFETY IS INVOLVED!



LEA EL INSTRUCTIVO

Si No Lee Ingles, Pida Ayuda a Alguien Que Si Lo Lea Que le Traduzca las Medidas de Seguridad.

Read and understand the complete Warranty Statement found in this Manual. Fill out the Warranty Registration Form in full and return it within 30 Days. Make certain the Serial Number of the Machine is recorded on the Warranty Card and on the Warranty Form that you retain. The use of "will-fit" parts will void your warranty and can cause catastrophic failure with possible injury or death.

TABLE OF CONTENTS

SAFETY SECTION	1-1
Safety Precautions	1-2
Safety Hazard Signal Words	1-7
Decal Locations	1-8
Safety Decals.	1-10
INTRODUCTION SECTION	2-1
Introduction	2-2
Specifications.	2-3
ASSEMBLY SECTION	3-1
Dismounting and Mounting Loader to Tractor	3-2
Mounting Attachment To Loader, Dismounting Attachment From Loader	3-3
OPERATION SECTION.	4-1
Preparing Tractor, Operating Loader, Filling Bucket	4-2
Lifting Load, Carrying Load, Dumping Bucket, Lowering Bucket.	4-3
Operating Float Control, Loading From Bank	4-4
Peeling & Scraping, Loading Truck & Spreaders From Pile, Backfilling	4-5
Handling Large Heavy Objects	4-6
Operating Grapple Fork	4-7
Operating Bale Spear	4-10
Operation of MSL.	4-11
MAINTENANCE SECTION	5-1
Daily Maintenance	5-2
Lift Cylinder Service	5-3
Tilt Cylinder Service	5-4
Replacing Wear Bushings	5-5
Adjusting Bucket Level Indicator	5-5
Hydraulic Trouble Shooting.	5-6
Torque Chart	5-7

SAFETY SECTION

Safety Section 1-1

SAFETY

SAFETY

SAFETY PRECAUTIONS

A careful operator operates best. Most accidents can be avoided by observing certain precautions. Read all precautions that follow before operating your tractor and loader to help prevent accidents. Equipment should be operated only by those who are responsible and instructed to do so.

GENERAL

1. Read your Operator's Manuals carefully before using tractor or loader. Lack of operating knowledge can lead to accidents.
2. Replace damaged or illegible safety decals. See pages 1-10 & 1-11 for required decals.
3. Operate tractor and loader only from operator's seat.

TRACTOR

1. Use an approved roll bar and seat belt for safe operation. Overturning a tractor without a rollbar can result in death or injury. If your tractor is not equipped with a rollbar and seat belt, see your Tractor Dealer.
2. Equip your tractor with FOPS (Falling Object Protective Structure) before installing or operating loader.
3. Always use seat belt when rollbar is installed. Do not use seat belt if rollbar is removed from tractor.
4. Add recommended wheel ballast and/or rear weight as recommended in owner's manual to provide good stability.
5. Move rear wheels to widest settings recommended to increase stability.
6. Move and turn tractor at low speeds.

LOADER

1. Improper use of a loader can cause serious injury or death.
2. Do not lift or carry anybody on loader, in bucket or on attachment.
3. Never allow anyone to get under loader bucket or reach through lift arms when bucket is raised.
4. Do not walk or work under a raised loader or bucket or attachment unless it is securely blocked or held in position.
5. Avoid overhead wires and obstacles when loader is raised. Contacting electric lines can cause electrocution.
6. Make sure all parked loaders are on a hard, level surface. Engage all safety devices.

OPERATING LOADER

1. As owner of this loader, it is your responsibility to be certain anyone operating this loader has read this manual first to be aware of safe operation of your tractor and loader.
2. Exercise caution when operating any loader with a raised loaded bucket or fork.
3. Avoid loose fill, rocks and holes. They can be dangerous for loader operation or movement.
4. Use care when operating on steep grades to maintain proper stability. Always carry bucket or attachment as low as possible.
5. Allow for loader length when making turns.

6. Stop loader arms gradually when lowering or lifting.
7. Use caution when handling loose or shiftable loads.
8. Carry bucket or attachment at a low position during transport for better visibility.
9. When parking or servicing, lower bucket to ground, stop engine and set park brakes before leaving tractor seat.
10. Operate loader controls only when properly seated at controls.
11. Using front end loaders without special attachments for handling large heavy objects such as large round or rectangular bales, logs and oil drums is **NOT RECOMMENDED**.
12. Handling large heavy objects can be extremely dangerous due to:
 - Danger of rolling tractor over.
 - Danger of upending tractor.
 - Danger of objects rolling or sliding down loader arms onto operator.
13. If you must perform this sort of work (see 12 above), protect yourself by:
 - Use proper attachments only.
 - Never lift load higher than necessary to clear ground when moving.
 - Ballast tractor rear to compensate for load.
 - Never lift large objects with equipment that does not have an anti-rollback device.
 - Move slowly and carefully, avoiding rough terrain.

MAINTENANCE

1. When servicing or replacing pins in cylinder ends, buckets, etc., always use a drift and hammer of non-sparking material. Failure to do so could result in injury from flying metal fragments.
2. Do not modify or alter or permit anyone else to modify or alter loader or any of its components or any loader function without first consulting your Dealer. If you have any questions regarding loader modifications contact your Rhino Dealer.
3. Always wear safety goggles when servicing or repairing tractor or loader.
4. Escaping hydraulic/diesel fluid under pressure can penetrate skin causing serious personal injury.
 - **DO NOT** use your hand to check for leaks. Use a piece of cardboard or paper to search for leaks.
 - Stop engine and relieve pressure before connecting or disconnecting hydraulic or diesel lines.
 - Tighten all connections before starting engine or pressurizing lines.
 - If any fluid is injected into skin, obtain medical attention immediately or gangrene may result.
5. Do not tamper with relief valve setting. Valve relief is factory-set. Changing relief setting can cause overloading of your tractor or loader and serious operator injury may result.

Whenever you see this symbol



It means: **ATTENTION!
BECOME ALERT!
YOUR SAFETY IS INVOLVED!**

SAFETY

PELIGRO!



Si no lee Ingles, pida ayuda a alguien que si lo lea para que le traduzca las medidas de seguridad.



¡LEA EL INSTRUCTIVO!

DANGER!



Never operate the Power Unit or Implement until you have read and completely understand this Manual, the Power Unit Operator's Manual, and each of the Safety Messages found in the Manual or on the Power Unit and Implement. Learn how to stop the Power Unit engine suddenly in an emergency. Never allow inexperienced or untrained personnel too operate the Power Unit and Implement without supervision. Make sure the operator has fully read and understood the manuals prior to operation.

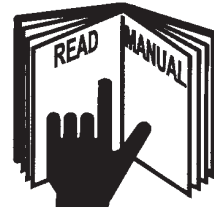

WARNING!



Always maintain the safety decals in good readable condition. If the decals are missing, damaged, or unreadable, obtain and install replacement decals immediately.

WARNING!



Make certain that the "Slow Moving Vehicle" (SMV) sign is installed in such a way as to be clearly visible and legible. When transporting the Equipment use the Power Unit flashing warning lights and follow all local traffic regulations.

WARNING!



Operate this Equipment only with a Tractor equipped with an approved roll-over-protective system (ROPS). Always wear seat belts. Serious injury or even death could result from falling off the tractor—particularly during a turnover when the operator could be pinned under the Operator Protective Structure.



WARNING!



Do not modify or alter this Implement. Do not permit anyone to modify or alter this Implement, any of its components or any Implement function.

DANGER!



BEFORE leaving the Power Unit seat, always engage the brake and/or set the Power Unit transmission in parking gear, disengage the auxiliary hydraulics, stop the engine, remove the key, and wait for all moving parts to stop. Place the Power Unit shift lever into a low range or parking gear to prevent the tractor from rolling. Never dismount a Power Unit that is moving or while the engine is running. Operate the Power Unit controls from the operator seat only.

SAFETY

SAFETY

DANGER!

Never allow children to operate or ride on the Power Unit or Implement.



DANGER!

Do not mount the Power Unit while the Power Unit is moving. Mount the Power Unit only when the Power Unit and all moving parts are completely stopped.



DANGER!

Start the Power Unit only when properly seated in the Power Unit seat. Starting a Power Unit in gear can result in injury or death. Read the Power Unit operator's manual for proper starting instructions.



DANGER!

Never work under the Implement, the framework, or any lifted component unless the Implement is securely supported or blocked up to prevent sudden or inadvertent falling which could cause serious injury or even death.



WARNING!

The operator and all support personnel should wear hard hats, safety shoes, safety glasses, and proper hearing protection at all times for protection from injury including injury from items thrown by the equipment.



WARNING!

PROLONGED EXPOSURE TO LOUD NOISE MAY CAUSE PERMANENT HEARING LOSS! Tractors with or without an Implement attached can often be noisy enough to cause permanent hearing loss. We recommend that you always wear hearing protection if the noise in the Operator's position exceeds 80db. Noise over 85db over an extended period of time will cause severe hearing loss. Noise over 90db adjacent to the Operator over an extended period of time will cause permanent or total hearing loss. *Note: Hearing loss from loud noise [from tractors, chain saws, radios, and other such sources close to the ear] is cumulative over a lifetime without hope of natural recovery*



SAFETY

DANGER!



Do not operate this Equipment with hydraulic oil leaking. Oil is expensive and its presence could present a hazard. Do not check for leaks with your hand! Use a piece of heavy paper or cardboard. High-pressure oil streams from breaks in the line could penetrate the skin and cause tissue damage including gangrene. If oil does penetrate the skin, have the injury treated immediately by a physician knowledgeable and skilled in this procedure.



DANGER!



Transport only at safe speeds. Serious accidents and injuries can result from operating this equipment at unsafe speeds. Understand the Power Unit and Implement and how it handles before transporting on streets and highways. Make sure the Power Unit steering and brakes are in good condition and operate properly.



Before transporting the Power Unit and Implement, determine the safe transport speeds for you and the equipment. Make sure you abide by the following rules:

1. Test the Power Unit at a slow speed and increase the speed slowly. Apply the Brakes smoothly to determine the stopping characteristics of the Power Unit and Implement. As you increase the speed of the Power Unit the stopping distance increases. Determine the maximum safe transport speed for you and this Equipment.
2. Test the equipment at a slow speed in turns. Increase the speed through the turn only after you determine that it is safe to operate at a higher speed. Use extreme care and reduce your speed when turning sharply to prevent the Power Unit and Implement from turning over. Determine the maximum safe turning speed for you and this equipment before operating on roads or uneven ground.
3. Only transport the Power Unit and Implement at the speeds that you have determined are safe and which allow you to properly control the equipment.

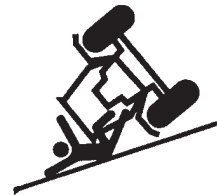

Be aware of the operating conditions. Do not operate the Power Unit with weak or faulty brakes. When operating down a hill or on wet or rain slick roads, the braking distance increases: Use extreme care and reduce your speed. When operating in traffic always use the Power Unit's flashing warning lights and reduce your speed. Be aware of the traffic around you and watch out for the other guy.

WARNING!



Never attempt to lubricate, adjust, or remove material from the Implement while it is in motion or while Power Unit engine is running. Make sure the Power Unit engine is off before working on the Implement!

WARNING!



Periodically inspect all moving parts for wear and replace when necessary with authorized service parts. Look for loose fasteners, worn or broken parts, and leaky or loose fittings. Make sure all pins have cotter pins and washers. Serious injury may occur from not maintaining this machine in good working order.



SAFETY

SAFETY

WARNING!



Always read carefully and comply fully with the manufacturers instructions when handling oil, solvents, cleansers, and any other chemical agent.



DANGER!



Never run the Power Unit engine in a closed building or without adequate ventilation. The exhaust fumes can be hazardous to your health.

DANGER!



KEEP AWAY FROM ROTATING ELEMENTS to prevent entanglement and possible serious injury or death.



DANGER!



Never allow children to play on or around Power Unit or Implement. Children can slip or fall off the Equipment and be injured or killed. Children can cause the Implement to shift or fall crushing themselves or others.

WARNING!



Do not exceed the rated PTO speed for the Implement. Excessive PTO speeds can cause Implement driveline failures resulting in serious injury.

DANGER!



NEVER use drugs or alcohol immediately before or while operating the Power Unit and Implement. Drugs and alcohol will affect an operator's alertness and coordination and therefore affect the operator's ability to operate the equipment safely. Before operating the Power Unit or Implement, an operator on prescription or over-the-counter medication must consult a medical professional regarding any side effects of the medication that would hinder their ability to operate the Equipment safely. **NEVER** knowingly allow anyone to operate this equipment when their alertness or coordination is impaired. Serious injury or death to the operator or others could result if the operator is under the influence of drugs or alcohol.



DANGER!



Operate the Power Unit and/or Implement controls only while properly seated in the operator's seat with the seat belt securely fastened around you. Inadvertent movement of the Power Unit or Implement may cause serious injury or death.

SAFETY

WARNING! Never interfere with factory-set hydraulic calibrations. Any change in calibration could cause a failure of the equipment and result in injury.



DANGER! Always shut the Power Unit completely down, place the transmission in park, and set the parking brake before you or anyone else attempts to connect or disconnect the Loader.



DANGER! Never crawl under a raised implement supported solely by the Power Unit boom. Release of the control lever or mechanical failure will result in the Implement falling and possible injury or death. Always securely block up the Implement before crawling underneath to perform repairs and service.



WARNING! Relieve hydraulic pressure prior to doing any maintenance or repair work on the implement. Place the Loader on the ground or securely supported on blocks or stands, disengage the auxiliary hydraulics and turn off engine. Push and pull the control levers several times to relieve pressure prior to starting any maintenance or repair work.



SAFETY HAZARD SIGNAL WORDS

There are three levels of hazard intensity identified by signal words DANGER, WARNING and CAUTION. The level of hazard intensity is identified by the following definitions.



DANGER - Immediate hazards which will result in severe injury or death.



WARNING - Hazards or unsafe practices which could result in minor personal injury or death.



CAUTION - Hazards or unsafe practices which could result in minor personal injury or property damage.



THIS SAFETY SYMBOL MEANS
ATTENTION!
BECOME ALERT!
YOUR SAFETY IS INVOLVED!

SAFETY

SAFETY

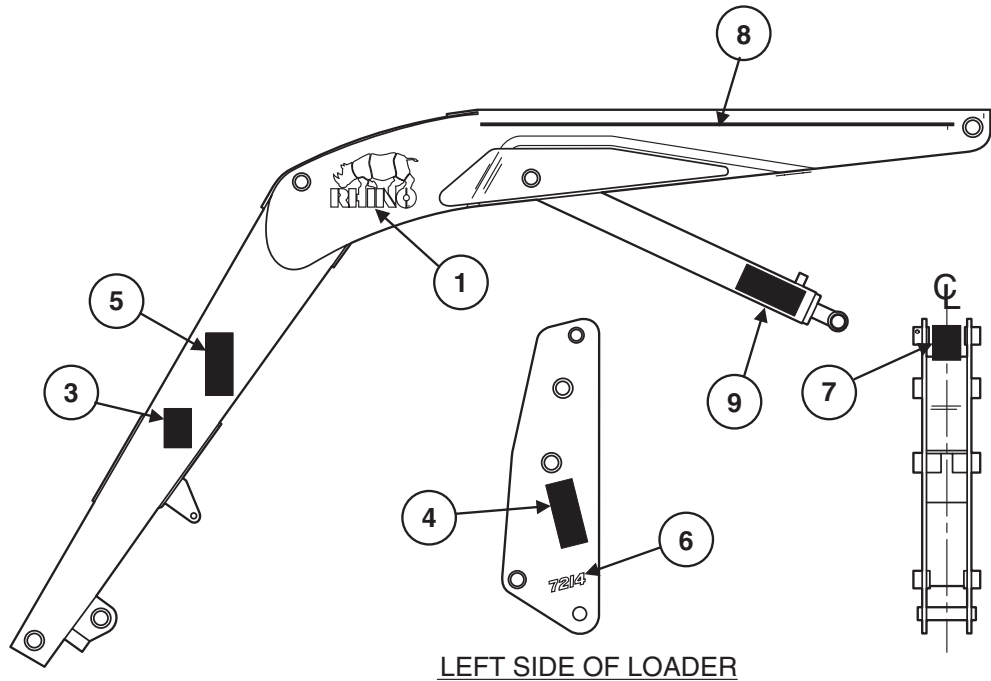

LEFT SIDE OF LOADER

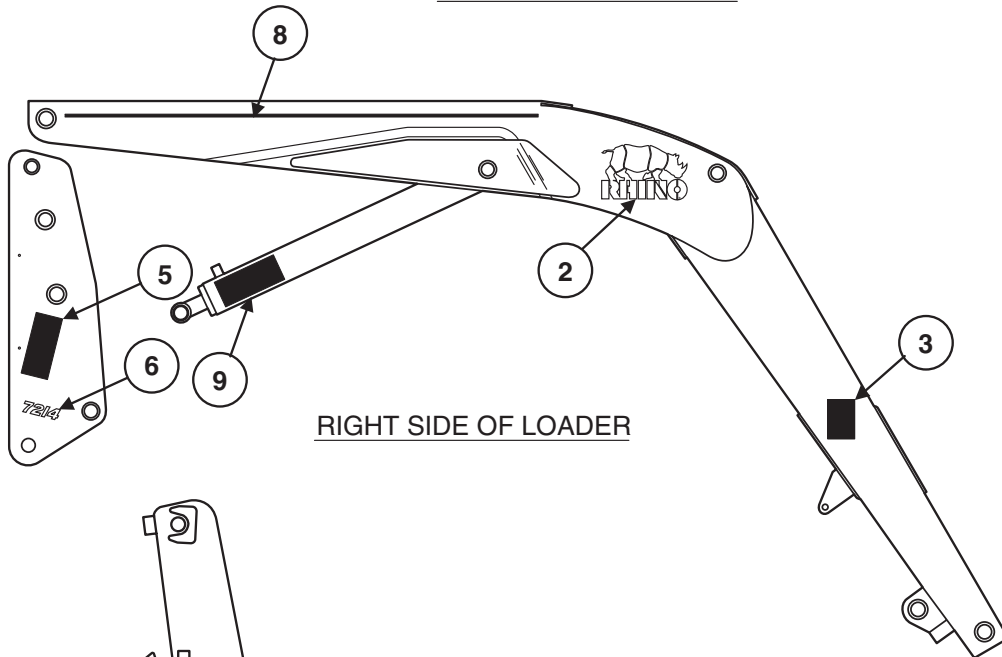

RIGHT SIDE OF LOADER

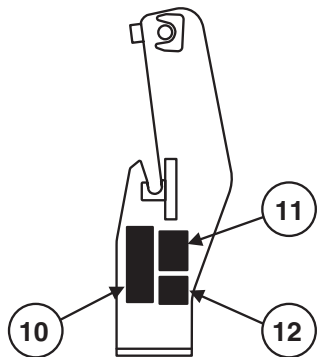

LEFT SIDE
LEFT MID
MOUNTING
BRACKET

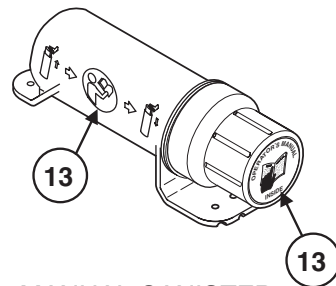

MANUAL CANISTER

SAFETY

ITEM	PART NO.	QTY.	TYPE	DESCRIPTION
1	49695	1	LOGO	Rhino, Left
2	51447	1	LOGO	Rhino, Right
3	48434	2	DANGER	Loader Safety
4	46776	1	WARNING	Loader Safety
5	51902	2	WARNING	Loader Removal/Reinstallation Safety
6	49703	2	MODEL	7214
7	48858	1	DANGER	Electric Shock
8	35674-5	2	STRIPE	White, 54"
9	48322	2	DANGER	Support Loader
10	47730	1	WARNING	Handling Bales/Do Not Carry People
11	48921	1	DANGER	Use ROPS, Seatbelt, Rear Ballast
12	46779	1	WARNING	Bucket Shift (Suspended Front Axle Only)
13	00776031	1	MANUAL CANISTER	Read Operator's Manual

SAFETY

SAFETY

NOTE: Safety decal locations are shown on page 1-8. Replace decal if damaged or illegible. Replacement decals are available from your dealer.

⚠ DANGER

- Do not walk or work under a raised loader.
- Lower loader to ground when parked.

Failure to comply may result in serious injury and/or death.

48434

3 - - 48434

⚠ DANGER

- Keep bucket and boom away from overhead electric lines.

Failure to comply will result in serious injury or death.

48858

7 - - 48858

⚠ DANGER

- Use ROPS and seatbelt at all times.
- Add recommended rear ballast.
- Operate tractor at low speeds.

Failure to comply may result in serious injury or death.

48921

11 - - 48921

⚠ DANGER

Loader support must be installed prior to working under raised loader. Failure to comply may result in serious injury or death.

48322

9 - - 48322

⚠ WARNING

- Do not handle round bales or large objects unless loader is equipped with proper attachments.
- Operate loader only with approved hydraulic valves.
- Handle raised loads with caution.
- Carry loads low.

Failure to comply may result in serious injury and/or death.

⚠ WARNING

- Do not lift or carry anybody in loader or work from bucket or any other attachment.

Failure to comply may result in serious injury or death.

47730

10 - - 47730

⚠ WARNING

LOADER SAFETY

Know all operation, warning and safety instructions in the operator's manual before operating the loader.

- Operate loader only from operator's seat.
- Carry bucket low during transport for better visibility and to avoid overturns.
- Use wheel ballast and / or rear weight for stability as recommended in the operator's manual.
- When parking or servicing unit, lower the bucket to the ground, stop engine, and set the parking brake to avoid tractor movement.

Failure to follow any of the instructions above can cause serious injury to the operator or other persons in are.

(Replacement manuals are available from your dealer.)

46776

4 - - 46776

⚠ WARNING

TO AVOID INJURY DURING REMOVAL OR REINSTALLATION OF LOADER

Read and understand instructions in operator's manual

- Make sure detached loader is parked on hard, level ground.
- Always have a bucket mounted to loader when it is removed from tractor.
- Do not permit bystanders within 10 feet of loader.
- Do not remove bucket or repair loader if it is not mounted on tractor.

Failure to comply could cause loader to collapse.

Failure to follow above instructions can cause serious injury.

51902

5 - - 51902

⚠ WARNING

When the loader is mounted to a tractor with SuperSteer™, the bucket will shift in the opposite direction from which the front wheels are turned.

Maximum shift will be approximately 8 inches and most noticeable when the tractor is stationary.

Failure to heed this warning can result in serious injury to the operator or other persons.

46779

12 - - 46779

SAFETY

SAFETY



1 - - 49695



2 - - 51447



6 - - 49703

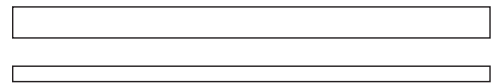

8 - - 35674-5

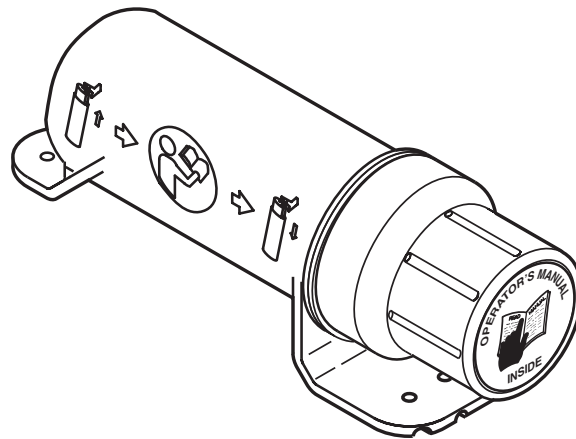

13 - - 00776031

SAFETY

FEDERAL LAWS AND REGULATIONS

This section is intended to explain in broad terms the concept and effect of federal laws and regulations concerning employer and employee equipment operators. This section is not intended as a legal interpretation of the law and should not be considered as such.

Employer-Employee Operator Regulations

U.S. Public Law 91-596 (The Williams-Steiger Occupational and Health Act of 1970) OSHA

This Act Seeks:

“...to assure so far as possible every working man and woman in the nation safe and healthful working conditions and to preserve our human resources...”

DUTIES

Sec. 5 (a) Each employer-

(1) shall furnish to each of his employees employment and a place of employment which are free from recognized hazards that are causing or are likely to cause death or serious physical harm to his employees;

(2) shall comply with occupational safety and health standards promulgated under this Act.

(b) Each employee shall comply with occupational safety and health standards and all rules, regulations and orders issued pursuant to this Act which are applicable to his own actions and conduct.

OSHA Regulations

OSHA regulations state in part: “At the time of initial assignment and at least annually thereafter, the employer shall instruct every employee in the safe operation and servicing of all equipment with which the employee is, or will be involved.”

Employer Responsibilities:

To ensure employee safety during Tractor and Implement operation, it is the employer's responsibility to:

1. Train the employee in the proper and safe operation of the Tractor and Implement.
2. Require that the employee read and fully understand the Tractor and Implement Operator's manual.
3. Permit only qualified and properly trained employees to operate the Tractor and Implement.
4. Maintain the Tractor and Implement in a safe operational condition and maintain all shields and guards on the equipment.
5. Ensure the Tractor is equipped with a functional ROPS and seat belt and require that the employee operator securely fasten the safety belt and operate with the ROPS in the raised position at all times.
6. Forbid the employee operator to carry additional riders on the Tractor or Implement.
7. Provide the required tools to maintain the Tractor and Implement in a good safe working condition and provide the necessary support devices to secure the equipment safely while performing repairs and service.
8. Require that the employee operator stop digging if bystanders or passersby come within 10 yards.

Child Labor Under 16 Years of Age

Some regulations specify that no one under the age of 16 may operate power machinery. It is your responsibility to know what these regulations are in your own area or situation. (Refer to U.S. Dept. of Labor, Employment Standard Administration, Wage & Home Division, Child Labor Bulletin #102.)

INTRODUCTION SECTION

Introduction Section 2-1

INTRODUCTION

INTRODUCTION

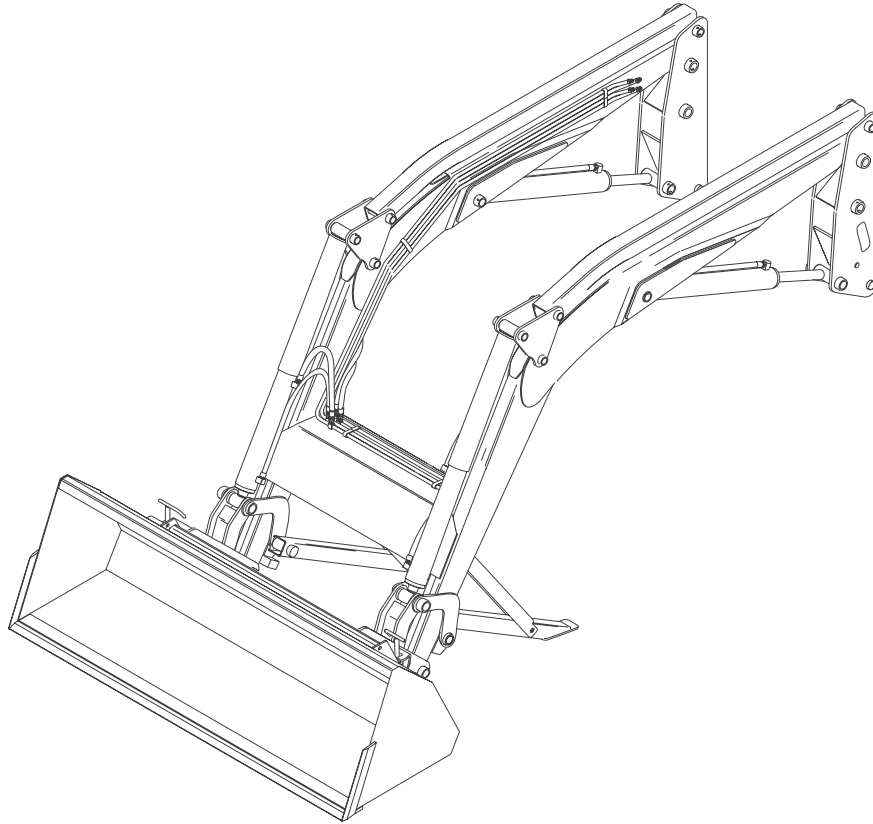

This manual provides operation, maintenance, assembly and parts identification for your new loader. Your loader has been designed to give many years of satisfactory service. Successful operation and long life of the loader depends on proper maintenance and operation. Please read this manual carefully and follow all instructions. Correct assembly, operation and maintenance will save you much time and expense. Also follow instructions included with loader mounting and hydraulic kits to insure that loader is installed correctly to tractor.



NOTE: This safety alert symbol identifies important safety messages in this manual. Observe and follow all safety messages to prevent personal injury.

Reference to left-hand and right-hand used in this manual refers to position of operator when seated in the operating position of loader.

If at any time you have a service problem with your loader or need new parts, contact your local dealer. Your dealer will need your loader model number and serial number to give you prompt efficient service.

Parts orders must give complete description, correct part number, total amount required, model number, all necessary serial numbers, method of shipment and shipping address.

INTRODUCTION

7214 SPECIFICATIONS

Specifications will vary with tractor, tire size, hydraulic system and bucket used. The specifications are given for a loader equipped with 96" H.D. material bucket, quick attach device and 4-bar linkage, operated with an average tractor hydraulic system of 25 GPM with engine operating at 2300 RPM, and control valve relief setting of 2750 PSI.

Break-away Capacity	
At Pivot Point	9260 #
800mm Forward of Pivot Point.	8540 #
Lift capacity at Full Height	
At Pivot Point	5840 #
800mm Forward of Pivot Point.	5140 #
Raising Time	6.6 sec.
Lowering Time	4.6 sec.
Attachment Dumping Time.	3.0 sec.
Attachment Rollback Time	2.9 sec.
Weight w/ Average Mounting Kit, Hose Kit, and 96" HD Material Bucket.	3603 #
Lift Cylinder:	
Stroke	28.88 in.
Piston Diameter	3.50 in.
Rod Diameter	1.75 in.
Bucket Cylinder:	
Stroke	16.00 in.
Piston Diameter	3.50 in.
Rod Diameter	1.75 in.
(A) Maximum Lift Height at Pivot Pin	169 in.
(B) Maximum Height Under Bucket.	159 in.
(C) Clearance with Bucket Dumped	133 in.
(D) Reach at Maximum Height.	44 in.
(E) Maximum Dump Angle	71°
(F) Reach with Attachment on ground	103 in.
(G) Attachment Rollback Angle	39°
(H) Digging Depth	4 in.
(J) Overall Height in Carry Position	89 in.

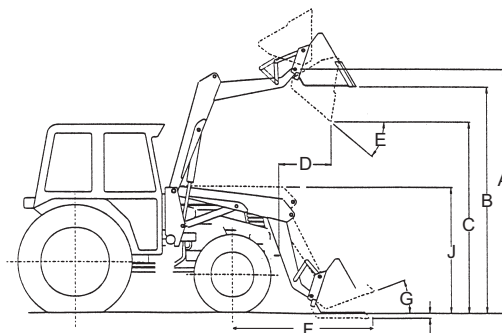

(Manufacturers estimated specifications and design subject to change without notice.)

ASSEMBLY SECTION

Assembly Section 3-1

ASSEMBLY

DISMOUNTING LOADER AND MOUNTING LOADER TO TRACTOR

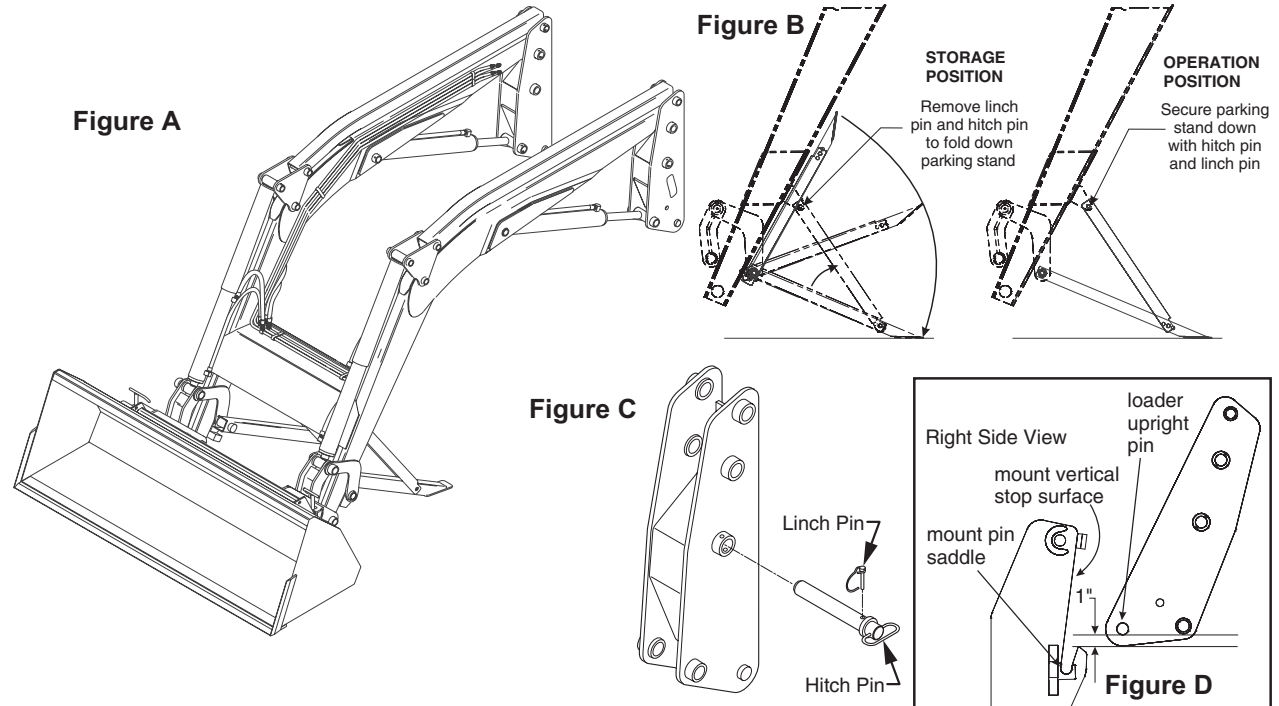

DISMOUNTING LOADER



WARNING: To avoid injury during installation or removal of loader, do not allow bystanders within 10 feet of loader and bucket or optional attachment.



WARNING: Always have a heavy attachment, such as a bucket, mounted to loader when it is removed from tractor. Pallet fork, bale spear, or similar attachments are too light to safely counterbalance loader boom arms when loader is dismounted from tractor.

1. Locate tractor and loader on firm level ground.
2. With bucket raised above ground, tilt down approximately 30 degrees from level.
3. Lower boom by retracting lift cylinders to lift tractor front end (tires can be off ground).
4. Stop engine. Allow tractor front end to lower by relaxing ONLY lift cylinders with control lever. This will remove pressure on hitch pins (see Figure C).

NOTE: Do not relax bucket cylinders.

5. Set parking brake. Rotate parking stands from storage position to operation position by removing lynch pins and hitch pins. Reinstall hitch pin and lynch pin when parking stands are in operation position (see Figure B).



CAUTION: Keep clear of dropping parking stands. Dropping parking stands could cause injury.

6. Remove lynch pins and 1-1/2" hitch pins from loader upright. Remove tarp strap securing loader hoses from tractor handrail.
7. Start tractor engine and release brakes. Retract bucket cylinders to allow parking stands to contact ground.



WARNING: It is important not to put excessive weight on parking stands by retracting lift cylinders. Damage may result.

8. Extend lift cylinders 10" to 12" to rotate top of loader uprights forward, out of mid mounting brackets, allowing tractor to be pushed rearward. Retract bucket cylinders until lower loader upright pins clear mount pin saddles and front tires and/or fenders (see Figure D).
9. Move tractor rearward approximately 6", taking care not to stretch hydraulic hoses.
10. Stop tractor engine and set parking brake. Relax lift cylinders and bucket cylinders by moving each control lever in both directions. Disconnect hydraulic hoses at mid mounting couplers on right side of loader. Install plastic dust plugs and caps on couplers.
11. Start tractor engine and release brakes. Slowly back tractor out of and away from loader.

ASSEMBLY

MOUNTING LOADER



WARNING: To avoid injury during installation or removal of loader or attachment, do not allow bystanders within 10 feet of loader and bucket or optional attachment.

1. Slowly drive tractor into loader and stop approximately 6" from mid mounting brackets. Shut off tractor engine and set parking brake.
2. Connect male couplers of hydraulic hoses to female quick couplers, matching corresponding colors. Make sure couplers are clean before connecting together.
3. Start engine and release parking brake. Make sure lift cylinders are extended 10" to 12". Stroke bucket cylinders to raise or lower uprights for loader upright pin to clear each mount pin saddle by approximately 1" (see Figure D on previous page).
4. Drive tractor forward until loader upright pins contact mount vertical stop surfaces just above mount pin saddles (see Figure D). Extend tilt cylinders to FULLY seat both loader upright pins into mount pin saddles and raise parking stands off ground. Retract lift cylinders, allowing tractor to move forward. Continue until loader uprights have fully seated into back of mount saddles by retracting lift cylinders to raise tractor front end (tires can be off ground).

5. Stop engine. Allow tractor front end to lower by relaxing ONLY lift cylinders with control lever.

NOTE: Do not relax tilt cylinders.

6. Set parking brake. Insert two 1-1/2 x 8" pins and linch pins.
7. Remove linch pins and hitch pins from parking stands, rotate parking stands into storage position, and secure stands in storage position with hitch pins and linch pins (Figure B on previous page).



CAUTION: Keep clear of parking stands when rotating up into storage position. Shearing action of parking stands when rotating into storage position could cause injury.

8. Use tarp strap to secure hoses to tractor handrail away from moving parts.

ASSEMBLY

DISMOUNTING AND MOUNTING BUCKET OR ATTACHMENT TO LOADER

MOUNTING QUICK ATTACH BUCKET OR OPTIONAL ATTACHMENT TO LOADER



WARNING: To avoid injury during installation of bucket or attachment do not allow bystanders within 10 feet of loader and bucket or attachment.

1. Locate tractor and attachment on level ground. Lower boom to three to five inches off ground.
2. Disengage latch pins by lifting handles and pulling toward rear so pins are held out of attachment ears.

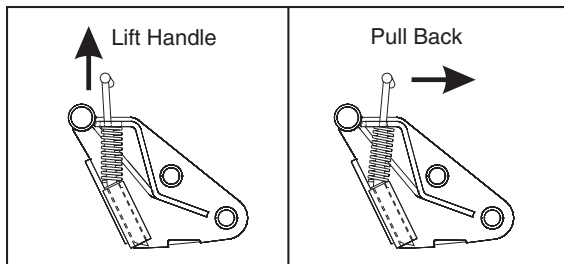

3. Extend bucket cylinders slightly, making sure loader quick attach bar is parallel to attachment. Continue driving very slowly toward attachment. Continue driving tractor forward, positioning quick attach bar so it touches attachment or bucket just below attachment channel.
4. Activate bucket rollback while moving tractor slightly ahead so quick attach bar catches underneath channel of attachment. Continue to roll attachment back completely so latch pins engage in bracket ears.
5. Activate lift cylinders to raise attachment and extend tilt cylinders to tilt attachment at a slight downward angle, so quick attachment mechanism is visible. Visually inspect mechanism to verify pins are engaged in ears on back of attachment.

NOTE: If bucket or attachment is not securely attached, follow instructions for detaching, then repeat above procedure.

ADJUSTING ATTACHMENT LEVEL INDICATOR

With various tractor tire options or attachments, it may be necessary to adjust attachment level indicator bracket up or down tilt cylinder tube. Tractor must be on level surface with attachment flat on surface. Loosen u-bolt to adjust. Offset on bucket level indicator rod should be at slotted hole when attachment is level.

DISMOUNTING QUICK ATTACH BUCKET OR OPTIONAL ATTACHMENT FROM LOADER



WARNING: To avoid injury during removal of bucket or attachment, do not allow bystanders within 10 feet of loader and bucket or attachment.

1. Locate tractor and loader on level ground.
2. Lower boom arms until bucket or attachment is level and approximately 3 inches off ground. Shut off tractor engine and engage tractor brakes.
3. Disengage latch pins by lifting handles and pulling toward rear so pins are held out of attachment ears.

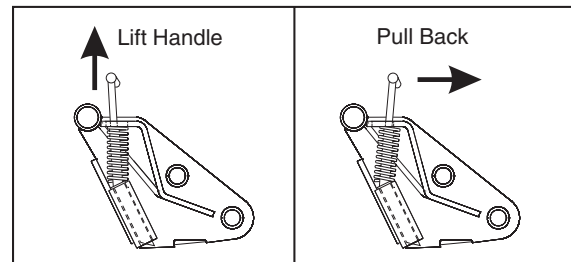

4. Start tractor engine, release tractor brakes and extend bucket cylinders while slowly backing tractor away from bucket or attachment, until quick attach bar disengages from attachment channel.

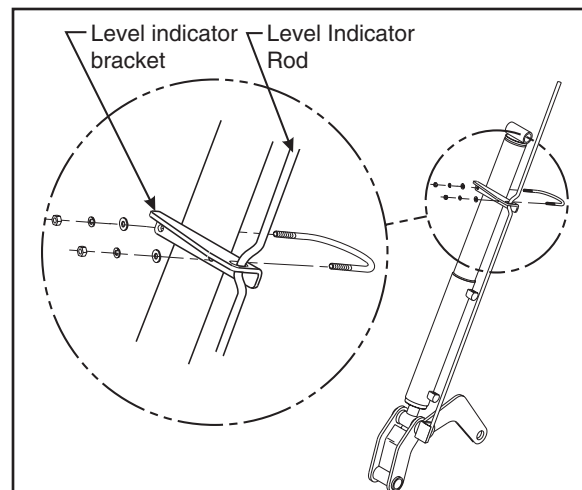

OPERATION SECTION

Operation Section 4-1

OPERATION

PREPARING TRACTOR PRIOR TO OPERATION



WARNING: Read all operator's manuals before inspecting, servicing or operating loader and tractor.

INSPECTION

Thoroughly inspect your fully assembled tractor and loader prior to operation.

1. Check all hardware to be sure that it has been properly installed and tightened. Retighten all hardware after 10 hours of initial operation.
2. Check tire pressure. Refer to tractor operator's manual for recommended pressures.
3. With tractor on level surface, compare tractor rear axle height from left to right, measuring from axle center to ground. Adjust air pressure in rear tires until axle height measures same for both sides.

NOTE: If rear axle on tractor is not level from side to side, cutting edge on loader bucket will not sit flat on ground.

4. Review tractor lubrication schedule and consult MAINTENANCE section of this manual to be certain all pivot points have been properly lubricated.
5. Use instructions listed in MAINTENANCE section of this manual to check all hose and tubing connections to insure no leaks are present.

INSTALL COUNTERBALANCE



WARNING: Before operating tractor and loader, add sufficient counterweight so a minimum of 25% of total weight of tractor, loader and rated load is on rear wheels when bucket contains rated load and is in maximum forward position.

Sufficient weight can be added to tractor by filling rear wheels with liquid ballast, installing wheel weights or 3-point hitch counterweight. If 3-point hitch counterweights are used, they should be carried as low as possible at all times to maximize stability. Effective counterbalance weight of mounted rear equipment is determined by multiplying actual weight of equipment by 1.50.

EXAMPLE: Equipment weighing 800 pounds, attached to rear of tractor, multiplied by 1.50, equals 1200 pounds of effective counterbalance weight.

After adding recommended counterweight, weigh tractor at rear axle to be sure counterbalance is adequate.

FILLING THE BUCKET

Approach and enter the pile with a level bucket.

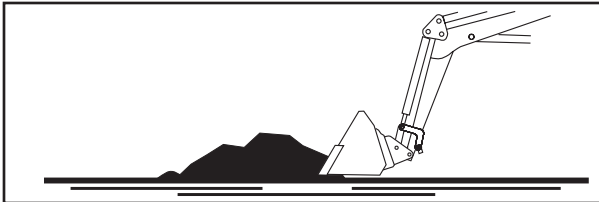

Loaders with 1-lever control, ease lever back and away from you to lift and roll back bucket.

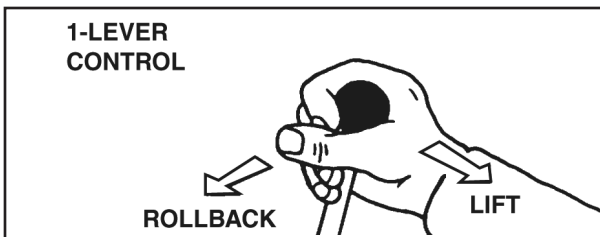

Loaders with 2-lever controls, ease both levers back to lift and roll back bucket.

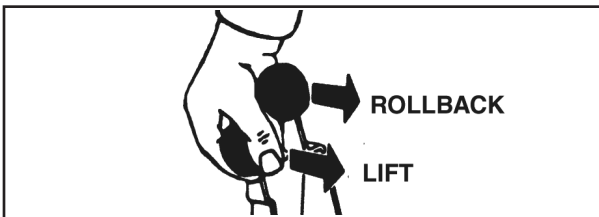

Lift and roll back of bucket will increase efficiency because...

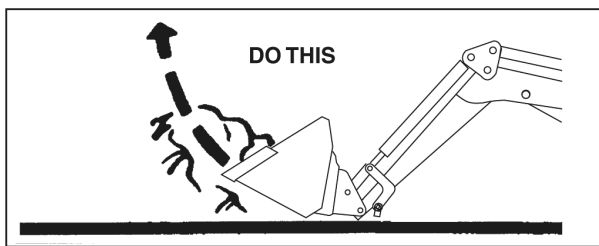

... A level bucket throughout the lifting cycle resists bucket lift and increases breakaway effort.

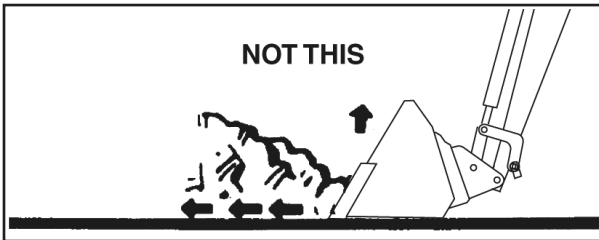

NOTE: Do not be concerned if the bucket is not completely filled during each pass. Maximum productivity is determined by the amount of material loaded in a given period of time. Time is lost if two or more attempts are made to fill the bucket on each pass.

OPERATION

LIFTING THE LOAD

When lifting the load, keep the bucket positioned to avoid spillage. Loader has mechanical self leveling of attachment in both raise and lower cycle. Attachment can be adjusted by using bucket cylinders.

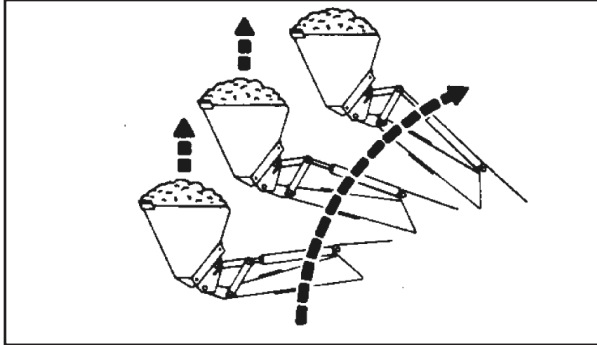

CAUTION: Do not attempt to lift loads in excess of loader capacity.

CARRYING THE LOAD

Position bucket just below tractor hood for maximum stability and visibility, whether bucket is loaded or empty.

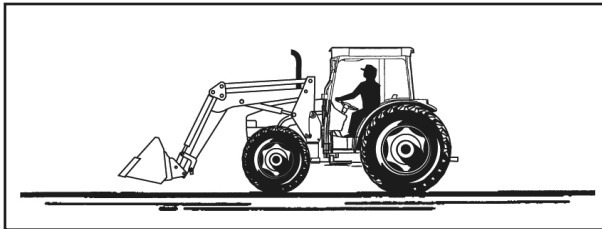

Use extreme care when operating loader on a slope, keep bucket as low as possible. This keeps center of gravity low and will provide maximum stability.



CAUTION: Operating loader on a hillside is dangerous. Extreme care is recommended. Keep bucket as low as possible.

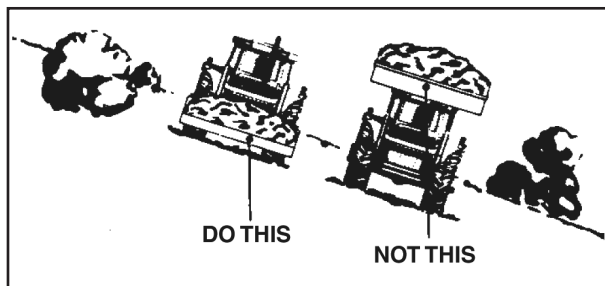

When transporting the load, keep bucket as low as possible, to avoid tipping, in case a wheel drops in a rut.

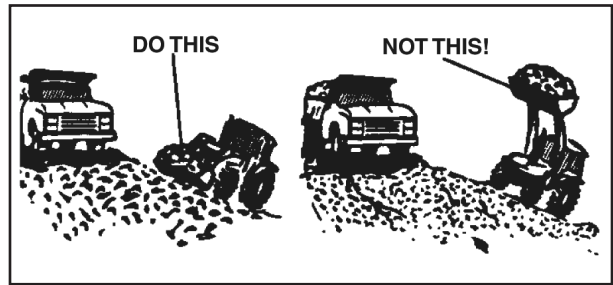

DUMPING THE BUCKET

Lift bucket high enough to clear side of vehicle. Move tractor in as close as possible to side of vehicle, then dump bucket.

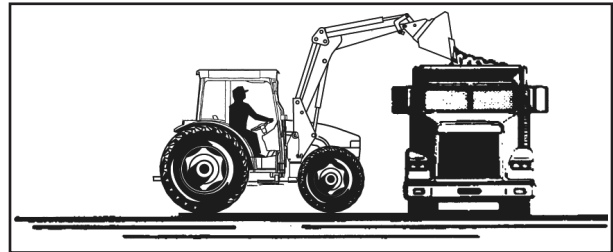

LOWERING THE BUCKET

After bucket is dumped, back away from vehicle while lowering and rolling back bucket.

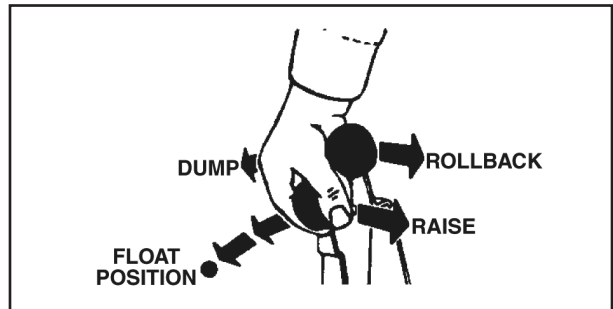
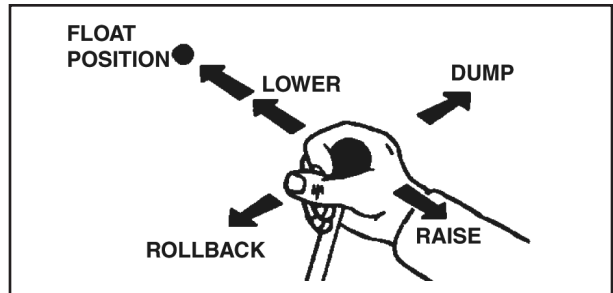

OPERATION

OPERATING WITH FLOAT CONTROL

During hard surface operation, keep bucket level and put lift control in float position to permit bucket to float on working surface. If hydraulic down pressure is exerted on bucket, it will wear faster than normal.

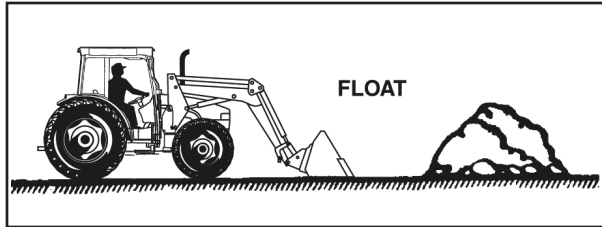

Float will also prevent mixing of surface material with stockpile material. Float position will reduce the chance of surface gouging when removing snow or other material, or when working with a blade.

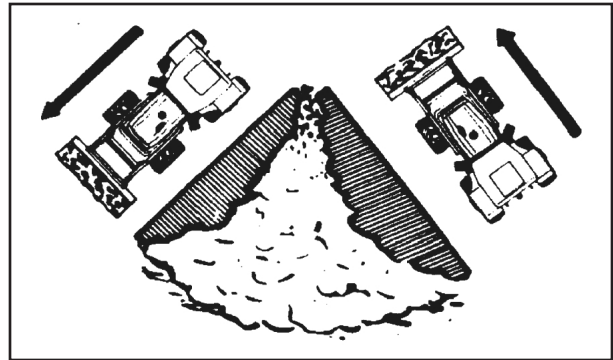
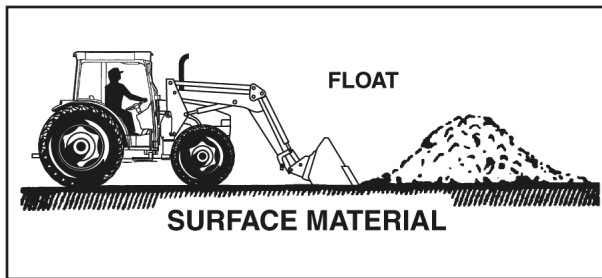

Sidecutting is a good technique for cutting down a big pile.

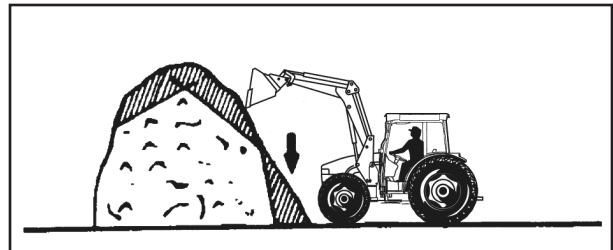

If the pile sides are too high and liable to cause cave-in, use loader to break down the sides until a slot can be cut over the top.

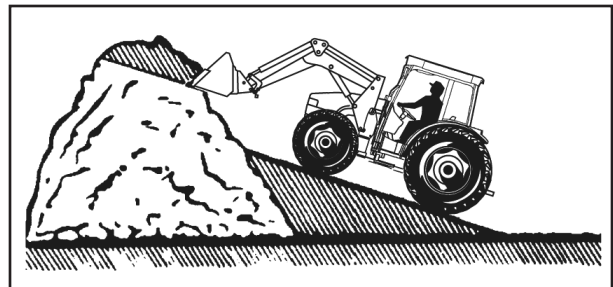

Another method for large dirt piles is to build a ramp approach to the pile.

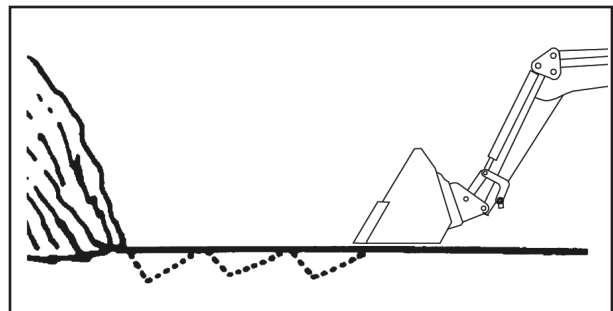

It is important to keep the bucket level when approaching a bank or pile. This will help prevent gouging the work area.

OPERATION

LOADING FROM A BANK

Choose a forward gear that provides sufficient ground speed for loading.

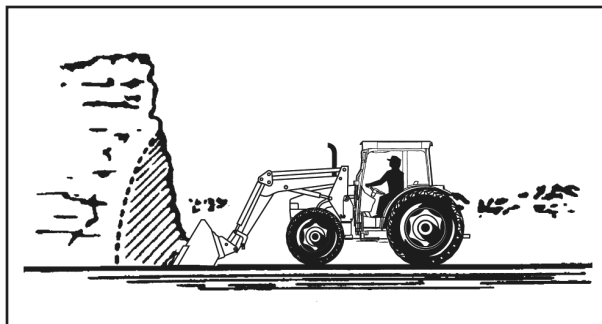

Exercise caution when undercutting high banks. Dirt slides can be dangerous. Load from as low as possible for maximum efficiency. Loader lift and breakaway capacity diminish as loading height is increased.

OPERATION

PEELING AND SCRAPING

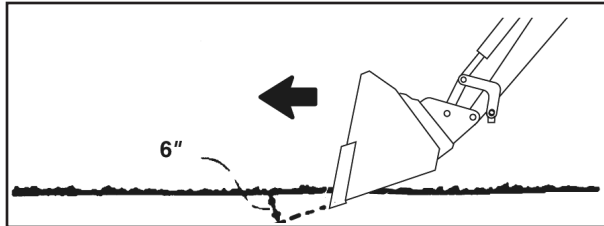

Use a slight bucket angle, travel forward and hold lift control forward to start the cut. Make a short 5 to 8 foot angle cut and break out cleanly.

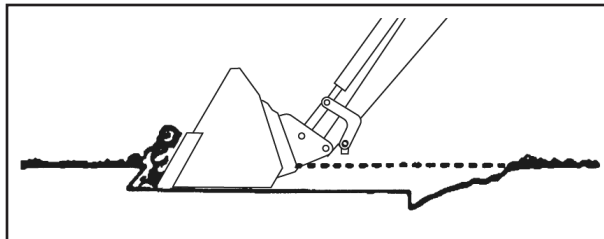

With bucket level, start a cut at notch approximately 2 inches deep. Hold depth by feathering bucket control to adjust cutting lip up or down. When front tires enter the notch, adjust lift cylinders to maintain proper depth.

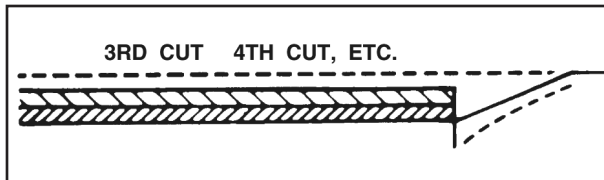

Make additional passes until desired depth is reached. During each pass, use only bucket control while working depth. This will allow you to concentrate on controlling bucket angle to maintain a precise cut.

LOADING LOW TRUCKS OR SPREADERS FROM A PILE

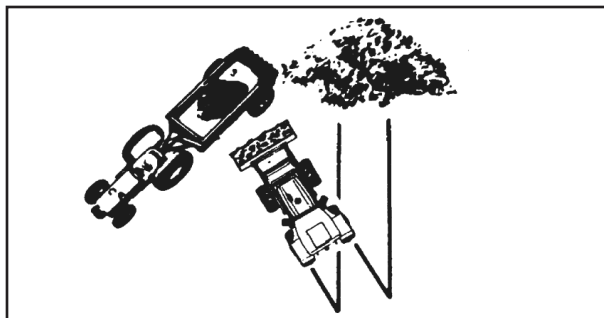

For faster loading, minimize angle of turn and length of run between pile and spreader.

Backgrade occasionally with a loaded bucket to keep working surface free of ruts and holes. Also, hold lift control forward so full weight of bucket is scraping ground.

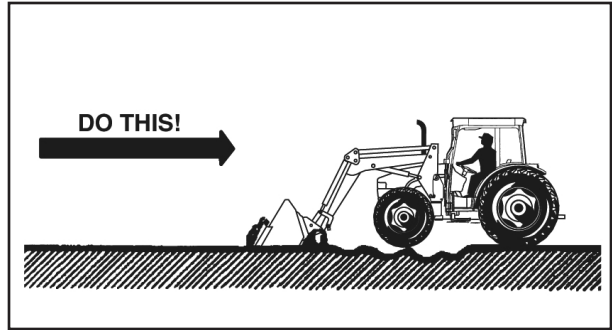

Do not roll bucket over and attempt to backgrade. This type of use can cause severe overloading of bucket cylinders when fully extended, possibly causing bucket cylinder rods to become bent.

BACKFILLING

Approach pile with a level bucket.

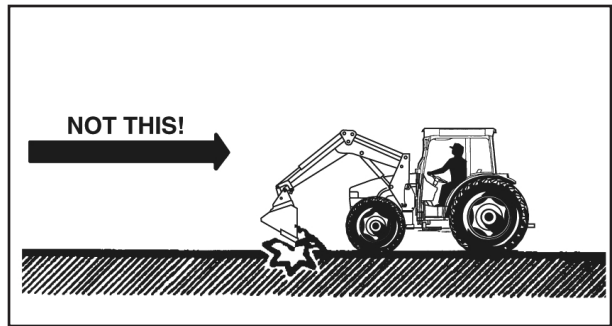

Poor methods actually move no more dirt and make it more difficult to hold a level grade.

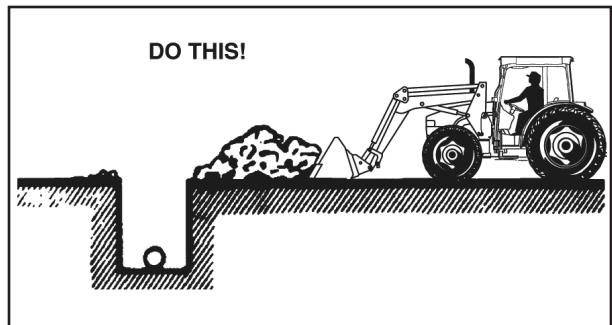

Do not use bucket in dumped position for bulldozing. This method, shown above, will impose severe shock loadings on dump linkage, bucket cylinder and tractor.

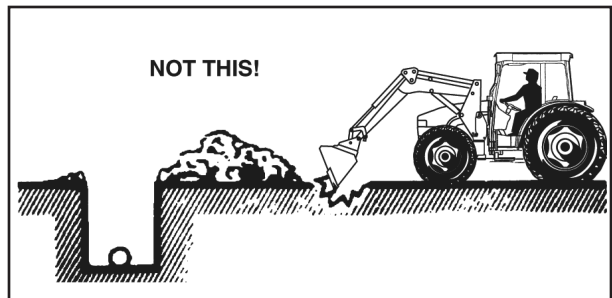

OPERATION

OPERATION

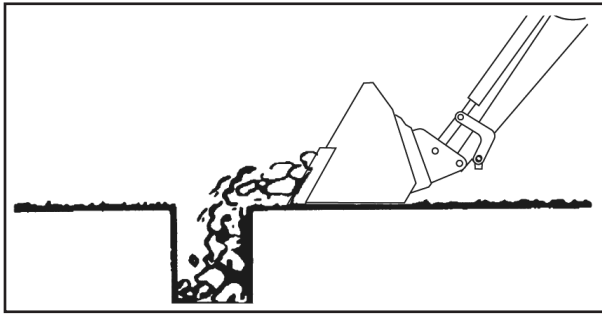

Leave dirt in bucket. Dumping on each pass wastes time.

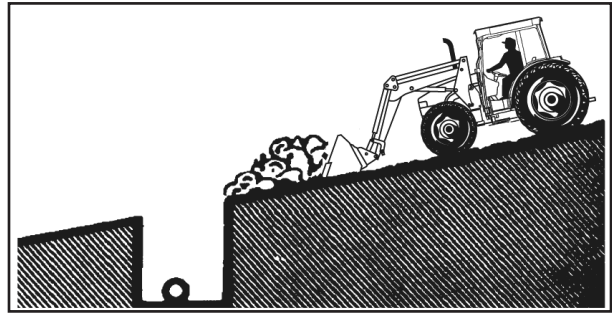

Pile dirt on high side for easier backfilling on a slope.

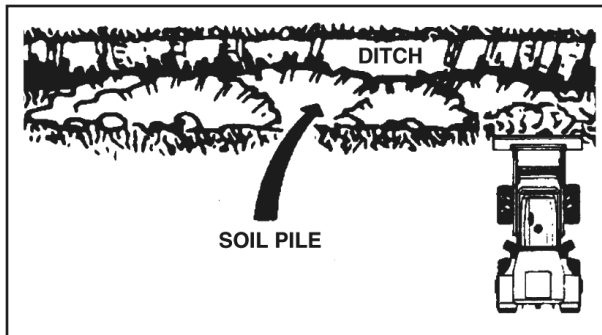

Operate tractor at right angles to ditch. Take as big a bite as tractor can handle without lugging down.

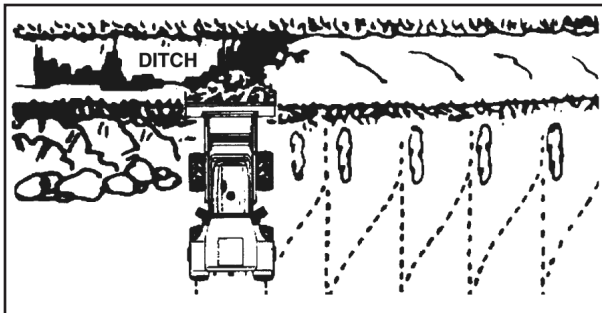

Leave dirt which drifts over side of bucket for final cleanup.

HANDLING LARGE HEAVY OBJECTS

DANGER

1. Using front end loaders for handling large heavy objects such as large round or rectangular bales, logs and oil drums is not recommended.
2. Handling large heavy objects can be extremely dangerous due to:
 - *Danger of tractor rolling over.*
 - *Danger of up-ending tractor.*
 - *Danger of object rolling or sliding down loader arms onto operator.*
3. If you must perform above work, protect yourself by:
 - *Never lifting load higher than necessary to clear ground when moving.*
 - *Ballasting tractor rear to compensate for load.*
 - *Never lifting large objects with equipment that does not have an anti-rollback device.*
 - *Moving slowly and carefully, avoiding rough terrain.*

OPERATION



**SAFE OPERATION
IS YOUR BEST PROTECTION
AGAINST ACCIDENTS**

OPERATION

OPERATING GRAPPLE FORK

Operation of your tractor and loader with grapple fork option requires some same basic considerations as operation with a bucket, plus two new requirements: you now have to operate a grapple while already operating your tractor and loader; and you must also take into account additional space requirements (added length and height) needed because of attached grapple fork.

INTENDED USE

Use of this loader without special attachments for handling large heavy objects such as large round or rectangular bales, logs and oil drums is **NOT RECOMMENDED**.

Handling large heavy objects can be extremely dangerous due to:

- *Danger of rolling tractor over.*
- *Danger of upending tractor.*
- *Danger of objects rolling or sliding down loader arms onto operator.*

If you must perform any work listed above, protect yourself by:

- *Never lift load higher than necessary to clear ground when moving.*
- *Ballast tractor rear to compensate for load.*
- *Never lift large objects with equipment that does not have an anti-rollback device.*
- *Move slowly and carefully, avoiding rough terrain.*

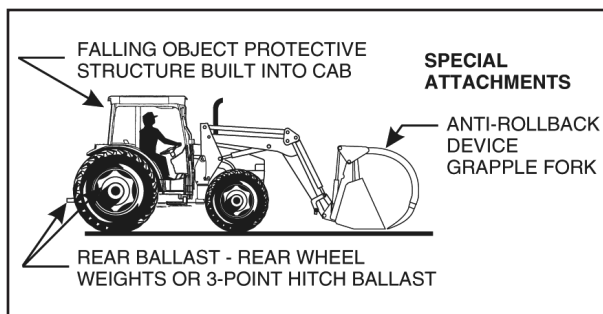

Using special attachments as shown, and exercising caution, your loader can be used to handle large round or rectangular bales and loose bulky materials like hay and silage. Do not attempt to use loader to handle logs, fertilizer bags or liquid containers since such use is **NOT RECOMMENDED**.

GRASPING ROUND BALES

Approach bale with grapple fork open and bucket level. Use loader float position if bale is on ground.

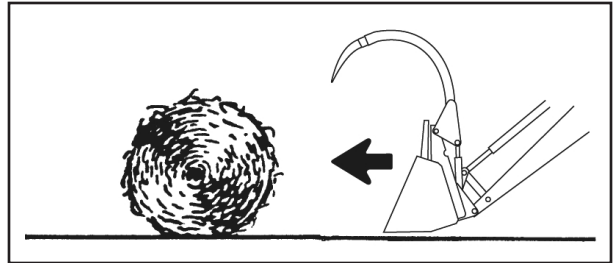

Ease valve control lever for grapple fork forward to close grapple fork around bale.

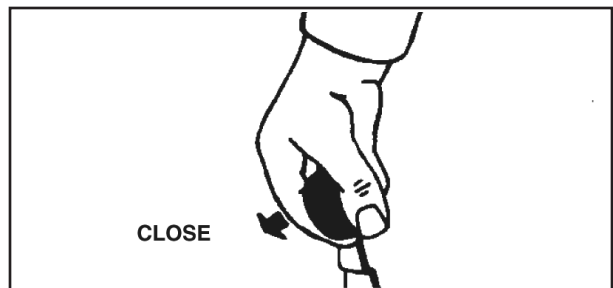

NOTE: While large round bales are best grasped as shown above, they may also be grasped from either side if necessary. **DO NOT ATTEMPT TO LIFT MORE THAN ONE LARGE ROUND BALE AT A TIME** as this can cause overloading of loader or tractor or cause unstable conditions.

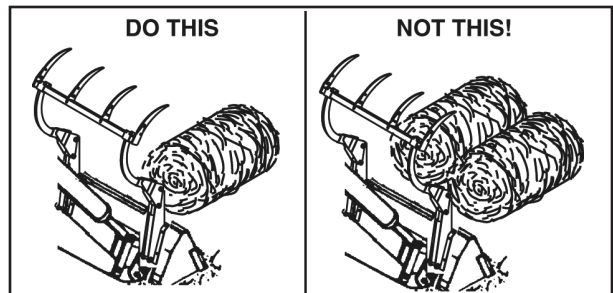

LIFTING AND CARRYING LOAD

Ease both loader control levers back to lift and roll bucket back.

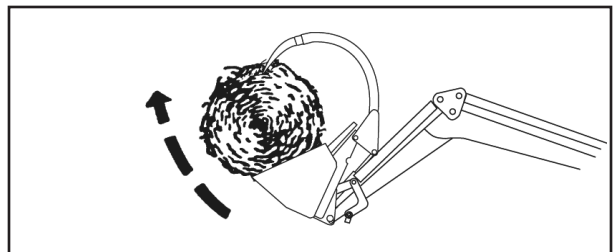

OPERATION

Position bucket just below level of tractor hood for maximum stability and visibility whether bucket is loaded or empty.

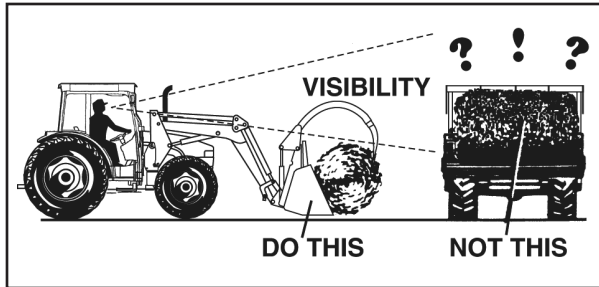

Use extreme care when operating loader on a slope. Carry load as low as possible. This keeps center of gravity for bale, tractor and loader low and will provide maximum tractor stability.



CAUTION: *Operating a loader on a hillside is dangerous. Extreme care is recommended to avoid overturns.*

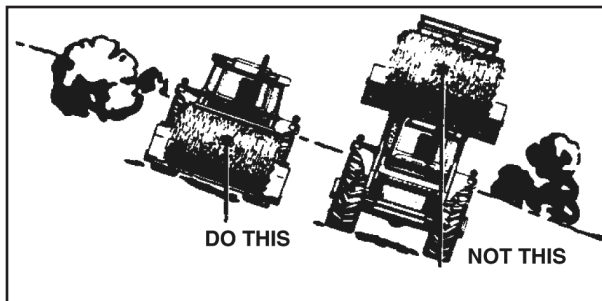

Even on level ground, transport bucket and load as low as possible to avoid tipping in case a wheel drops in a rut and to avoid power lines.

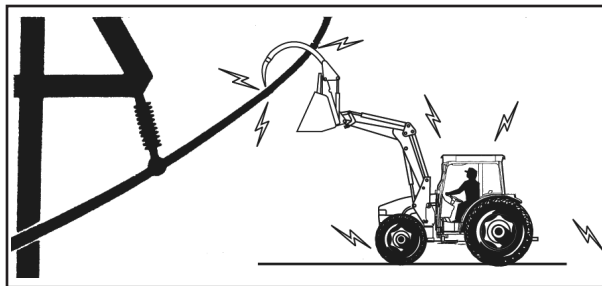

WARNING: *Keep bucket, grapple fork and loader boom clear of overhead lines. Allowing loader boom or any attachments to contact overhead power lines may electrify entire tractor and electrocute (kill) operator.*

LOADING INTO TUB GRINDER

Lift bucket high enough to clear tub grinder sides. Move tractor toward tub grinder to position load near center. Extend bucket cylinders to position bucket in dump attitude.

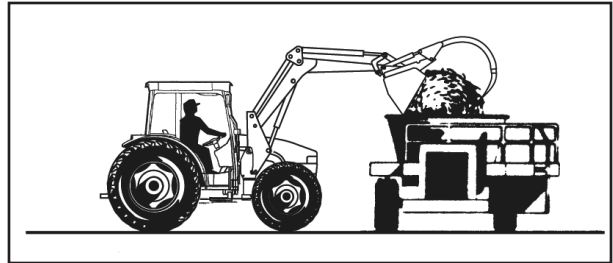

Gradually open grapple fork tines, allowing material to drop into tub grinder. For round bales it may be necessary to gradually set bale into tub grinder to avoid shock loading tub grinder due to bale weight and to avoid sudden load on grinder mechanism.

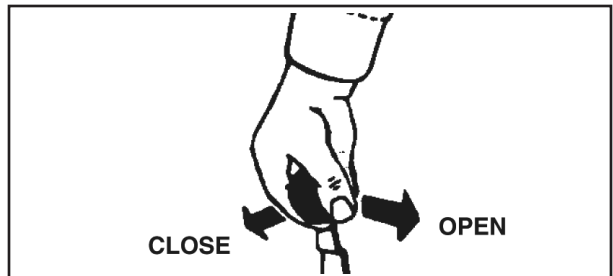

Roll bucket back, close grapple fork and back tractor away from tub grinder, then lower loader boom after dumping.

STACKING BALES



WARNING: *Because of size and weight of large bales, extreme care must be taken in handling them. Be aware of forces acting on stacked bales due to gravity and keep workers far from zones of potential hazard from shifting or falling bales. DO NOT ALLOW BYSTANDERS!*

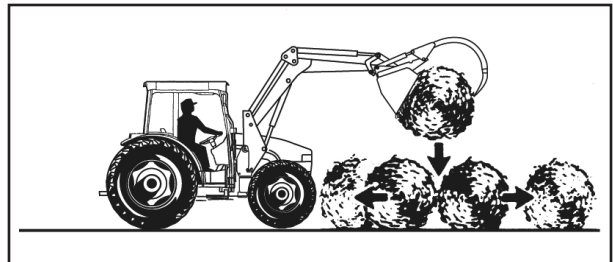

Use loader and grapple fork to gently position bale on stack, then release bale while removing bucket and fork.

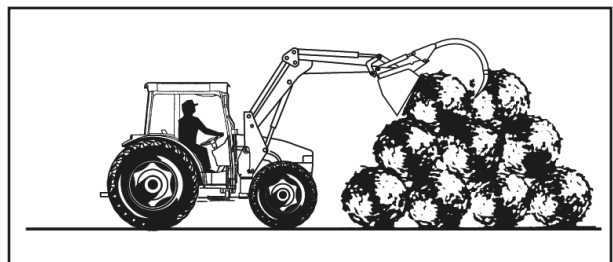

OPERATION

Slowly back tractor away from stack.

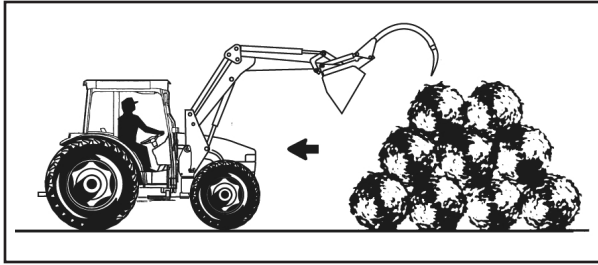

LOADING FROM A STACK, BUNKER SILO OR PIT SILO

Choose a forward gear that provides sufficient ground speed for loading.

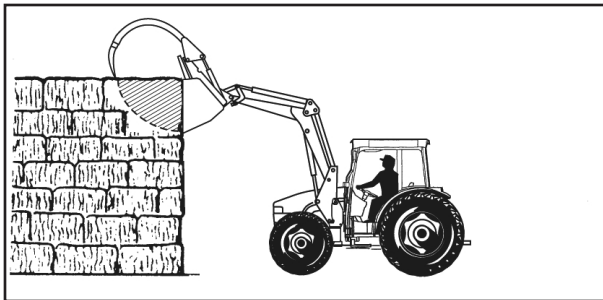

Touch pile as near as possible to top with bucket positioned in dump attitude and grapple fork open. Close grapple fork while maneuvering bucket to grasp loose material.



CAUTION: Loader lift and break-away capacity diminish as loader height is increased. Care must be taken not to grasp more material than your loader can safely support.

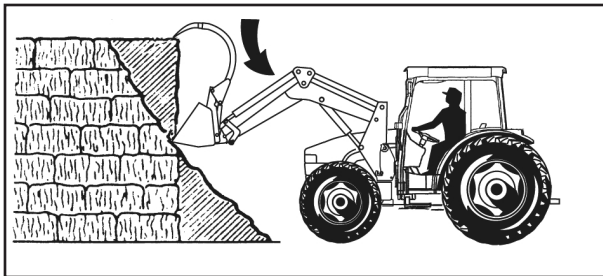

An alternative method is to use your loader and grapple fork to knock material down from top of pile so it can be loaded from ground.

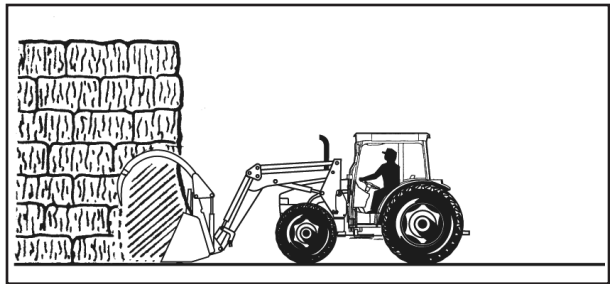

Exercise caution when undercutting a high pile. Avalanching material can be dangerous.

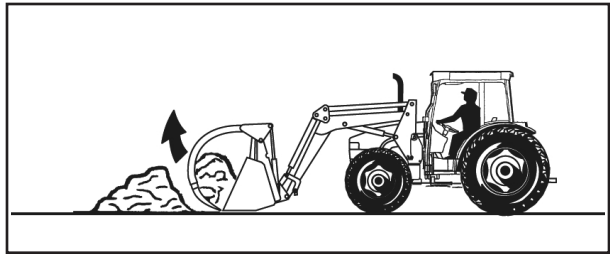

When loading material from ground, keep a level bucket and use lift control float position. If hydraulic down pressure is exerted on a bucket, it will wear faster than normal. Keep bucket level when approaching pile.

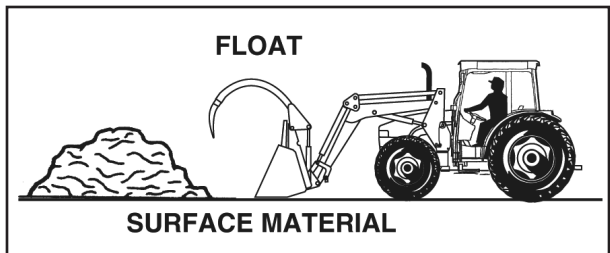

Keeping a level bucket and using loader float will reduce surface gouging and mixing surface material with stockpile material.

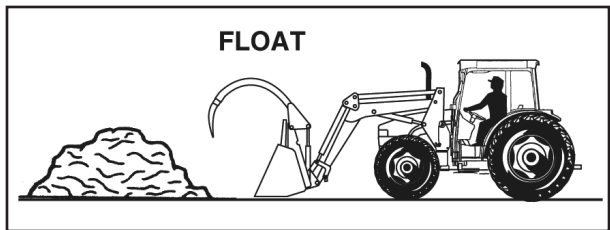

When a sufficient amount of material has accumulated in front of bucket, close grapple fork to grasp material and curl bucket.

OPERATION

OPERATING BALE SPEAR

Loader equipped with bale spear is designed to handle round bales up to 2000 pounds.



WARNING: Operate bale spear using extreme caution. Sharp points on bale spear can cause serious injury or death.

Load bale spear by approaching from round end to prevent cutting strings or puncturing plastic or net wrap.

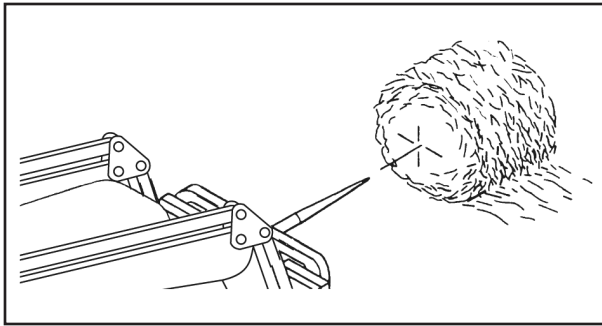

Tilt bale spear upward to prevent bale from falling off of spear.

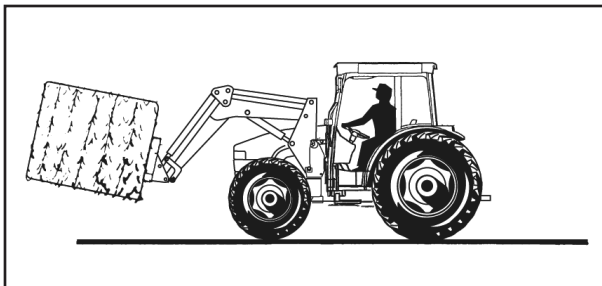

Carry bales as low to the ground as possible to allow maximum visibility and avoid tipping.



WARNING: Because of size and weight of large bales, extreme care must be taken in handling them. Be aware of forces acting on stacked bales due to gravity and keep workers far from zones of potential hazard from shifting or falling bales. **DO NOT ALLOW BYSTANDERS!**

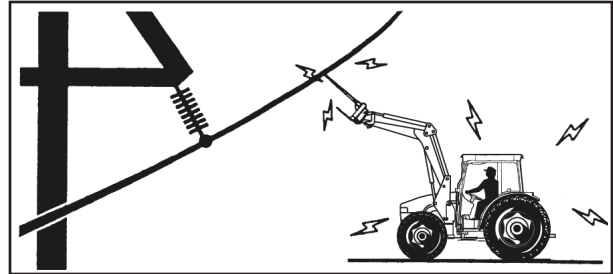

WARNING: Keep bale spear and loader boom clear of overhead lines. Allowing loader boom or any attachments to contact overhead power lines may electrify entire tractor and electrocute (kill) operator.

OPERATION

OPERATION AND NOMENCLATURE OF MSL (Mechanical Self Leveling) LOADER

MSL maintains the attitude of loader bucket or attachment relative to ground as set by the operator using the tilt cylinders. Constant attitude is maintained when lift cylinders raise or lower boom, as long as no tilt adjustment is made.

MSL consists of linkages connected to loader uprights and extending forward to triangular pivot plates. Equal displacement tilt cylinder base ends are attached to the pivot plates and rod ends are attached to another linkage commonly referred to as a "four-bar linkage." The four-bar linkage, which allows increased dump and rollback rotation connects to bucket or attachment.

Hydraulic relief for tilt cylinders is required when raising the boom with attachment fully dumped. The attachment contacts dump stops on underside of front ends of boom. While raising boom, MSL system pushes attachment tighter against dump stops and tilt cylinder base end pressure increases. A hydraulic relief valve cartridge allows the pressurized oil to transfer to rod end of tilt cylinder, eliminating excessive loads on MSL system. Hydraulic relief is not necessary when lowering boom.

IMPORTANT: It is important that the tilt cylinder oil line tubes and hoses are correctly plumbed for proper operation of MSL relief valve. Refer to diagram below. Pressure setting for relief valve is set at 210 bar (3,045 psi) and **MUST** be maintained at that level. The cartridge is stamped with required 210 bar setting.

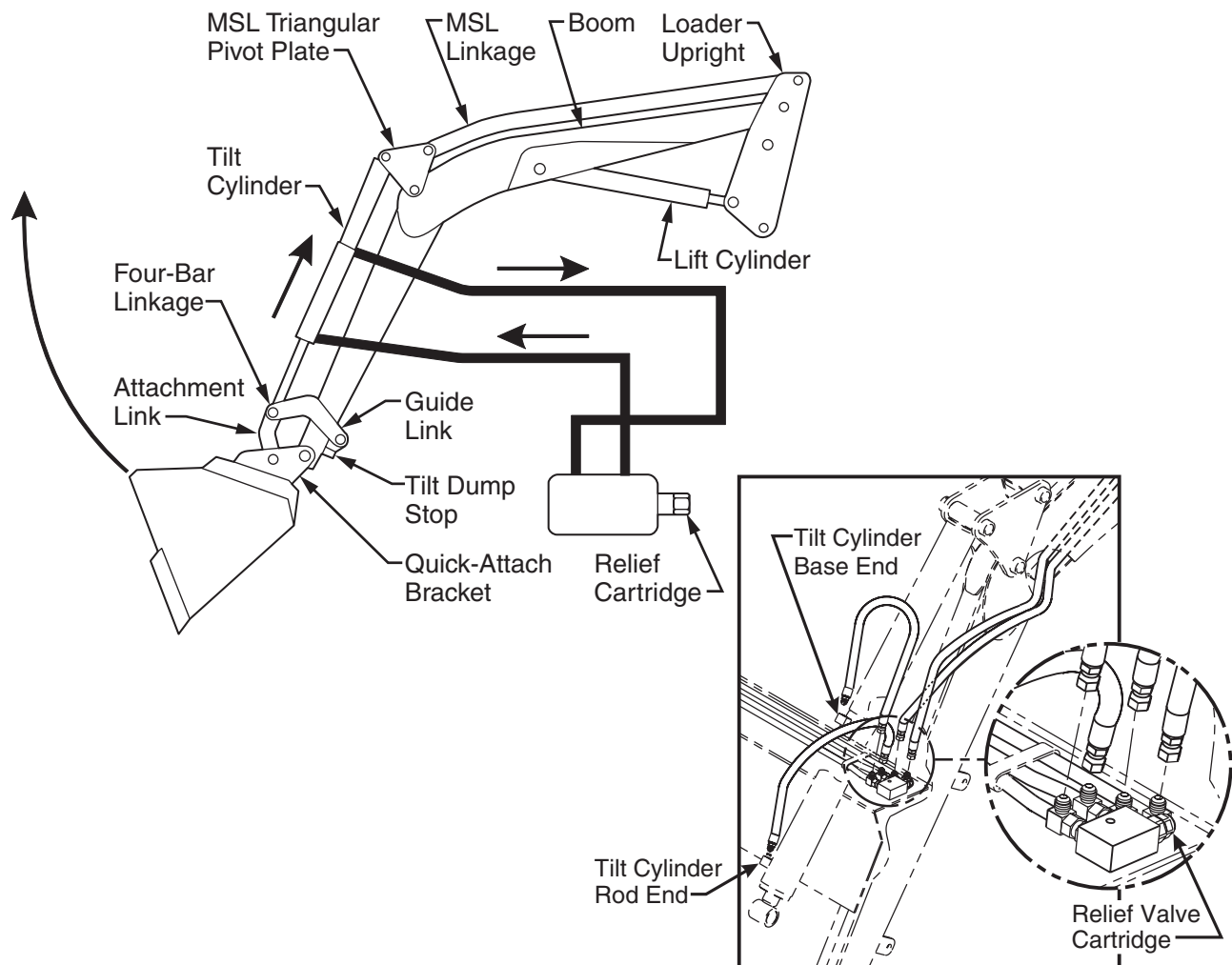

MAINTENANCE SECTION

Maintenance Section 5-1

MAINTENANCE

Regular maintenance of your loader and hydraulic system will ensure maximum loader efficiency and long life.



WARNING: NEVER perform maintenance beneath a raised loader unless loader is properly supported to prevent accidental lowering.

DAILY MAINTENANCE

- Check fluid level of tractor hydraulic system before starting each day's operation. If necessary, add hydraulic oil as recommended in your tractor operator's manual.
- Every four hours of operation, lubricate all twenty-two grease fittings. One grease fitting on the end of each pin, accessible from outside the loader.
- Repair hydraulic oil leaks promptly to avoid loss of oil and serious personal injury from escaping oil.
- Replace hoses immediately if they are damaged by a cut or scrape, extruded at the fittings, or leaking.
- After every ten hours of operation, check all hardware and tighten where required.



WARNING: Escaping hydraulic fluid under pressure can penetrate skin, causing serious personal injury.

- DO NOT use your hand to check for leaks. Use a piece of wood or cardboard and wear eye protection to search for leaks.
- Stop engine and relieve pressure before connecting or disconnecting lines.
- Tighten all connections before starting engine or pressurizing lines.

If any fluid is injected into skin, obtain medical attention immediately or gangrene may result.

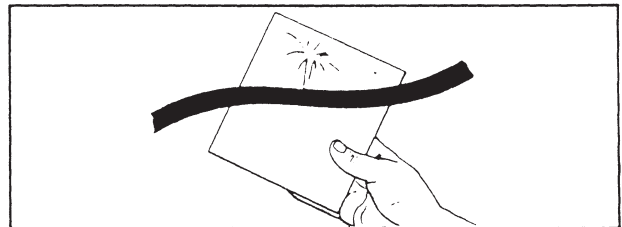

Grease Fitting Locations

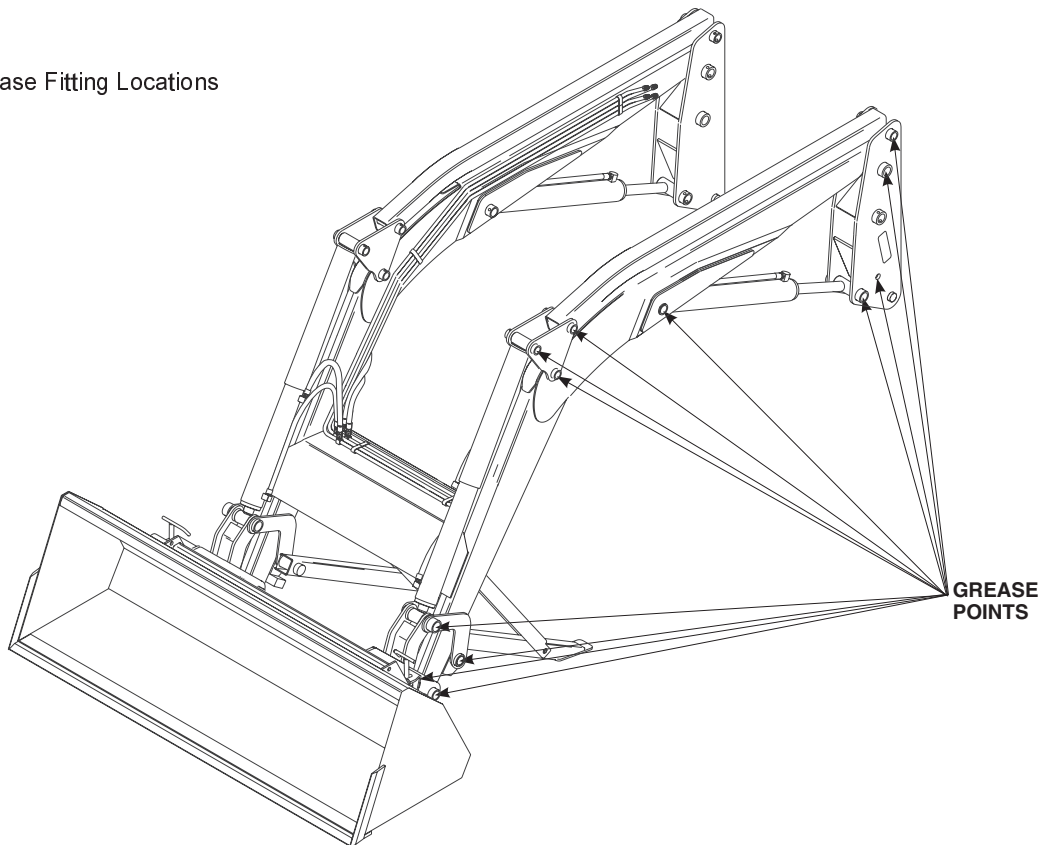

MAINTENANCE

MAINTENANCE

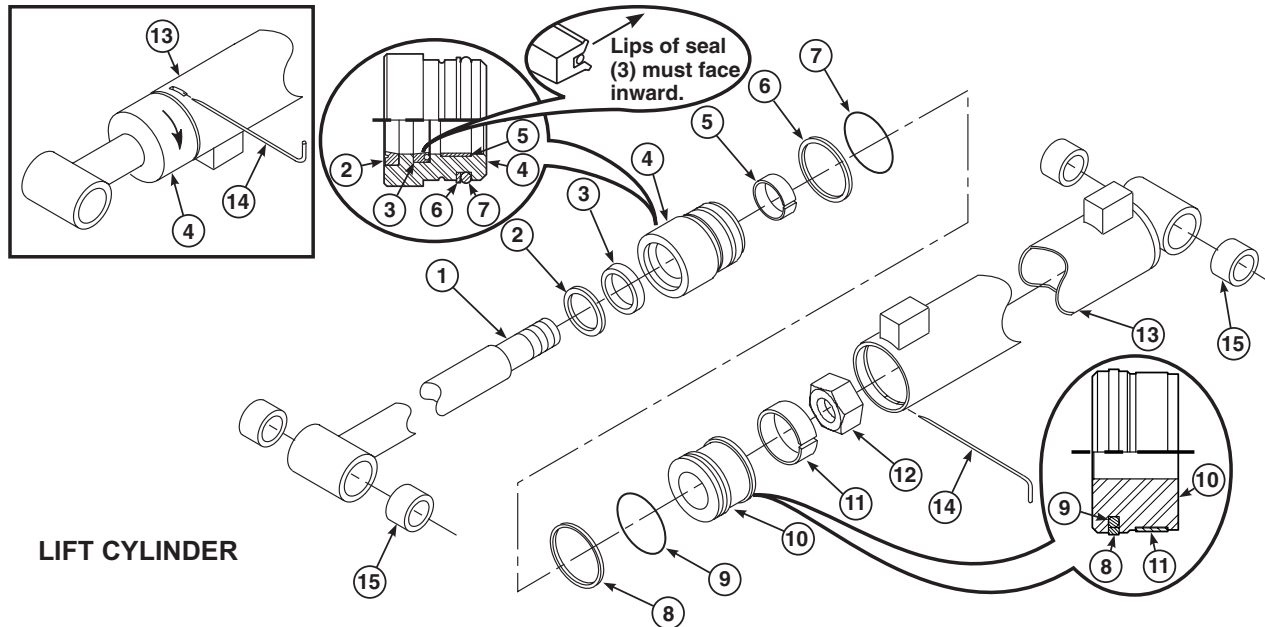

LIFT CYLINDER

CYLINDER SERVICE

Loader cylinders are designed to be reliable and easy to service. If a cylinder should malfunction during warranty period, return complete cylinder assembly, without disassembling, to your authorized service department or contact your authorized service department for instructions. Unauthorized disassembly of a cylinder in warranty period will **VOID WARRANTY**.

Following is an outline procedure for disassembling and reassembling cylinders.

LIFT CYLINDER DISASSEMBLY

1. Remove cylinder from loader.
2. Hold cylinder tube (13) stationary and pull wire ring (14) out through slot.
3. Pull shaft (1), with all assembled parts, out of cylinder tube (13).
NOTE: Resistance will be felt until piston seal (8) slides over wire retaining ring groove.
4. Remove elastic lock nut (12) from end of shaft and slide cylinder piston (10) and cylinder head (4) off shaft.
5. Remove piston wear ring (11), piston seal (8), and o-ring (9) from outside grooves on piston (10).
6. Remove wiper seal (2), rod seal (3), and wear ring (5) from inside of cylinder head (4) and o-ring (7) with backup washer (6) from groove on outside of head.
7. Clean all parts, including cylinder tube, in a suitable cleaning solvent, then use air pressure to blow any dirt or excess solvent from all parts.
8. Examine all parts for wear or damage and replace, if necessary.

LIFT CYLINDER REASSEMBLY

NOTE: Be careful not to damage seals and o-rings on edges or holes in cylinder tube. Inspect and remove burrs and sharp edges if necessary before reassembly.

1. Place rod seal (3) into groove inside cylinder head (4).
NOTE: Lips of seal (3) must face inward and seal must be firmly seated in groove.
2. Install wiper seal (2) with lip of seal facing out and flush with top of cylinder head (4). Install wear ring (5) inside other end of head (4).
3. Place o-ring (7) with backup washer (6) in groove on outside of head (4). Backup washer must be to rod side.
4. Remove sharp edges on outer edge of threaded end of shaft (1). Lubricate wiper seal (2) and rod seal (3) in head (4) and carefully slide head (4) onto shaft.
5. Place o-ring (9), piston seal (8), and piston wear ring (11) in grooves on outside of piston (10).
NOTE: For easier installation, place piston seal (8) in 120°F water to warm seal.
6. Slide piston (10) onto threaded end of shaft and install elastic lock nut (12). Tighten elastic lock nut to 575 ft·lbs. torque.
7. Lubricate piston wear ring (11) and piston seal (8) on piston (10), o-ring (9) on head (4) and inside of cylinder tube (13), then carefully slide piston and head into cylinder tube (13).
8. Insert wire retaining ring (14) into slot in cylinder tube (13). Apply pressure to wire ring to thread it into groove while turning cylinder head.

MAINTENANCE

MAINTENANCE

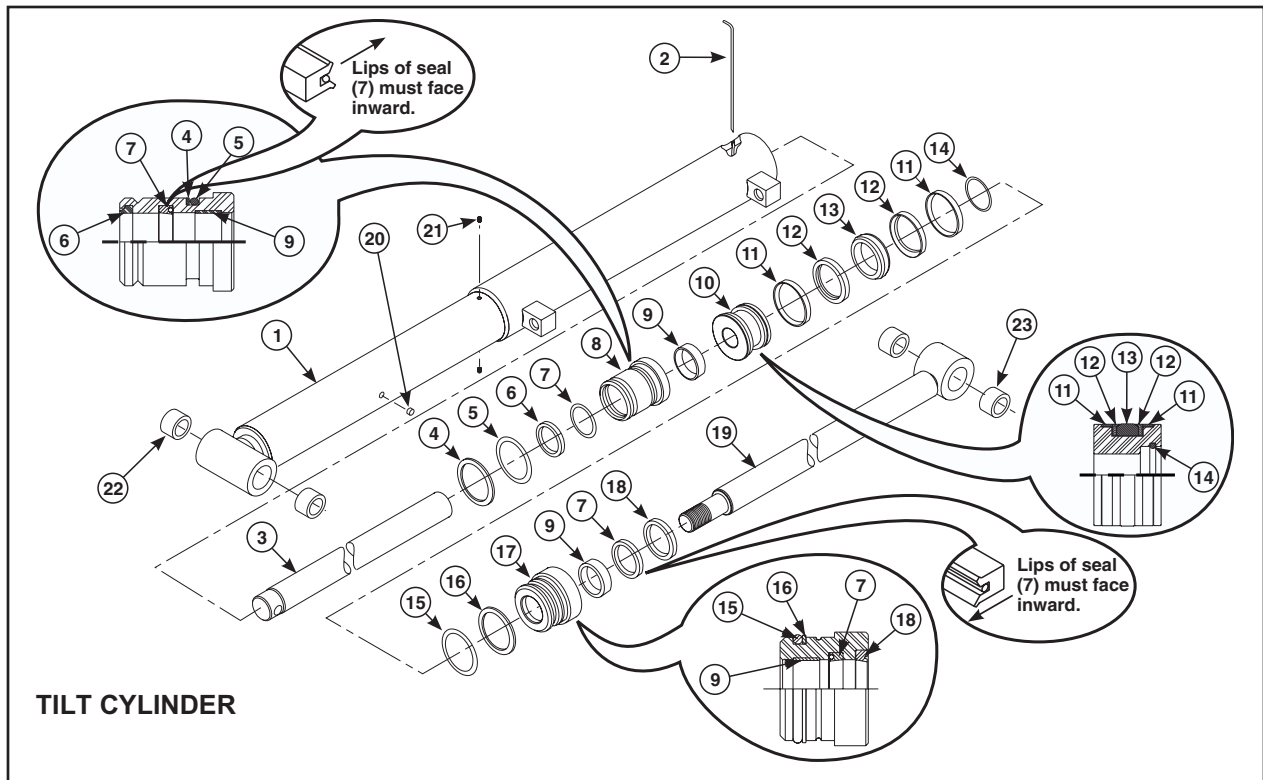

TILT CYLINDER

TILT CYLINDER DISASSEMBLY

1. Remove cylinder from loader.
2. Secure cylinder in a vise and manually extend and retract cylinder rod to remove oil in cylinder.
3. With cylinder rod fully extended, remove set screws (21) from cylinder. Remove plug (20) and apply air pressure into hole where plug was removed. This will unseat internal head (8) and move it along cylinder rod.
4. Hold cylinder tube (1) stationary and pull retaining wire (2) out through slot while turning head (17) in same direction.
5. Pull shaft (19) with all assembled parts out of cylinder tube (1).
6. Remove internal head (8) from cylinder shaft.
7. To remove piston from rod assembly, hold shaft assembly by placing a rod through hole in shaft (3) and a shaft through cross head shaft (19) and turn counterclockwise.
8. Remove wiper seal (6), rod seal (7), and wear ring (9) from inside cylinder head (8), and backup ring (4) and o-ring (5) from groove on outside of head (17).
9. Remove wiper seal (18), rod seal (7), and wear ring (9) from inside cylinder head (17), and o-ring (15) with backup ring (16) from groove on outside of head (17).

10. Remove piston wear rings (11), support rings (12), and seal (13) from outside groove of piston (10).

11. Clean all parts, including cylinder tube, in suitable cleaning solvent, then use air pressure to blow away any dirt or excess solvent from all parts.

12. Examine all parts for wear or damage and replace, if necessary.

TILT CYLINDER REASSEMBLY

NOTE: Be careful not to damage seals and o-rings on edges or holes in cylinder tube. Inspect and remove burrs and sharp edges if necessary before reassembly.

1. Place rod seal (7) into groove inside cylinder heads (8 & 17).

NOTE: Lips of seal (7) must face pressure side of cylinder as shown in cutout illustrations of head assemblies and seal must be firmly seated in grooves.

2. Install wiper seal (6) with lip of seal facing out into groove on cylinder head (8).
3. Install wiper seal (18) with lip facing out and flush with top of cylinder head (17).
4. Install wear ring (9) inside other end of cylinder heads (8 & 17).
5. Place backup ring (16) and o-ring (15) in groove on outside of head (17). Make sure o-ring and backup ring are installed as shown in cutout illustration for head (17).

MAINTENANCE

MAINTENANCE

TILT CYLINDER REASSEMBLY CONTINUED

- Place o-ring (5) and backup ring (4) in groove in outside of head (8). Make sure o-ring and backup ring are installed as shown in cutout illustration for head (8).
- Remove sharp edges on outer edge of threaded end of shaft (19). Lubricate wiper seal (18) and rod seal (7) in head (17) and carefully slide head onto shaft in orientation shown.
- Place o-ring (14) into groove inside piston, and seal components (11-13) into groove on outside of piston. Lubricate o-ring (14) and slide piston onto threaded shaft (19) in orientation shown.
- Clean internal and external threads on shafts (19 & 3) with parts cleaner, dry and apply Loctite® 271 to threads on shaft (19), then assemble shaft (3) to cross head shaft (19). Tighten to 450-500 ft. lbs. torque.
- Lubricate o-ring (5), backup ring (4), wiper seal (6), and rod seal (7). Carefully slide cylinder head (8) into cylinder tube (1), then into inner tube. Turn tube (1) with open end facing up and use a shaft or tube to seat head into tube. Be careful not to score cylinder wall. Install plug (20), apply Loctite and install set screws (21) in place. Seat set screws equally from each side.
- Apply a light coating of oil to shaft and piston seals. Turn tube (1) horizontal and secure in vise. Turn shaft, piston, and head assembly so hole in shaft (3) is horizontal and slide into cylinder, guiding rod into head (8).
- Lubricate o-ring (15) and backup ring (16), then carefully slide piston and head into cylinder tube (1).
- Insert wire retaining ring (2) into slot in cylinder tube (1). Apply pressure to wire ring to thread it into groove while turning cylinder head.

REPLACING WEAR BUSHINGS

Loader lift and tilt cylinders are manufactured with replaceable wear bushings at each end. (Refer to cylinder illustrations on previous pages.) Wear bushings are designed to be easily replaced using tools ordinarily available.

- Use a drift pin to remove wear bushing.
- Press replacement bushing in place using mallet and block of wood, or similar method.

ADJUSTING ATTACHMENT LEVEL INDICATOR

With various tractor tire options or attachments, it may be necessary to adjust attachment level indicator bracket up or down tilt cylinder tube. Tractor must be on level surface with attachment flat on surface. Loosen u-bolt to adjust. Offset on bucket level indicator rod should be at slotted hole when attachment is level.

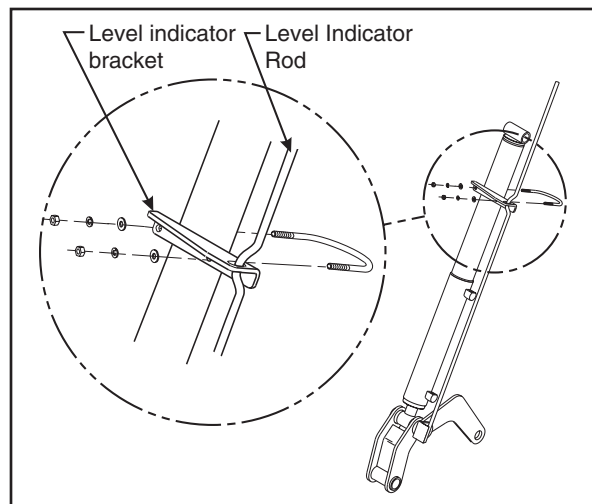

THIS SAFETY SYMBOL MEANS

ATTENTION!
BECOME ALERT!
YOUR SAFETY IS INVOLVED!

MAINTENANCE

MAINTENANCE





TROUBLESHOOTING

PROBLEM	POSSIBLE CAUSE	REMEDY
1. Loader slow or will not lift and/or dump.	<ol style="list-style-type: none"> 1. Hydraulic oil too heavy. 2. Oil filter plugged. 3. Hydraulic pump worn. 4. Oil line restricted or leaking. 5. Control valve does not shift properly. 6. Air in hydraulic system. 7. Cylinder leaks internally. 8. Faulty relief valve (tractor). 	<ol style="list-style-type: none"> 1. Change to proper oil. 2. Clean or replace filter. 3. Repair or replace pump. 4. Check all hoses and tubes for leaks, damage or restrictions. Replace damaged or restricted hoses or tube oil lines. 5. Inspect, clean, repair or replace valve. 6. Cycle lift cylinders and bucket cylinders several times to free system of air. 7. Replace seals. 8. Clean or replace relief valve.
2. Loader chatters or vibrates when raising or lowering.	<ol style="list-style-type: none"> 1. Air leak in pump inlet line. 2. Air in hydraulic system. 3. Oil level too low. 4. Faulty relief valve (tractor). 	<ol style="list-style-type: none"> 1. Check, tighten or replace inlet line. 2. Cycle lift and bucket cylinders. 3. Add oil as required. 4. Replace relief valve.
3. Loaded bucket dumps or uncurls when control valve is in neutral.	<ol style="list-style-type: none"> 1. Control valve spool is leaking. 2. Control linkage binding. 3. Cylinder seals bypassing oil. 	<ol style="list-style-type: none"> 1. Contact your Dealer. 2. Inspect, adjust or repair linkage. 3. Repair or replace cylinders.
4. External leakage.	<ol style="list-style-type: none"> 1. Damaged seals. 	<ol style="list-style-type: none"> 1. Remove leaking component and replace seals.
5. Pump noisy.	<ol style="list-style-type: none"> 1. Inlet line restricted or leaking. 2. Oil level too low. 3. Pump worn or damaged 	<ol style="list-style-type: none"> 1. Check for air leaks, restrictions or collapsed hose. Tighten or replace hose. Clean filter if necessary. 2. Add oil as required. 3. Repair or replace pump.
6. Excessive wear on bucket cutting edge.	<ol style="list-style-type: none"> 1. Bucket is riding on cutting edge instead of wear pads. 	<ol style="list-style-type: none"> 1. Use boom "FLOAT" position or bucket level indicator to ensure bucket rides on wear pads.
7. Loader raises when bucket is rolled back.	<ol style="list-style-type: none"> 1. Air in lift cylinder lines. 	<ol style="list-style-type: none"> 1. Slowly cycle all cylinders to purge system of air. Replenish hydraulic system.
8. Bucket cutting edge not flat on the ground.	<ol style="list-style-type: none"> 1. Rear axle on tractor not level from side to side. 	<ol style="list-style-type: none"> 1. With tractor on level surface, compare rear axle height from left to right, measuring from axle center to ground. Adjust air pressure in rear tires until axle height measures the same for both sides.

MAINTENANCE

GENERAL TORQUE SPECIFICATIONS

USE THE FOLLOWING TORQUES WHEN SPECIAL TORQUES ARE NOT GIVEN

AMERICAN STANDARD CAP SCREWS										METRIC CAP SCREWS							
SAE Grade	5				8				Metric Class	8.8				10.9			
Typical Grade ID Markings on Head									Typical Grade ID Markings on Head								
Cap Screw	TORQUE				TORQUE				Cap Screw	TORQUE				TORQUE			
Size	FT-LBS		N-m		FT-LBS		N-m		Size	FT-LBS		N-m		FT-LBS		N-m	
Inches	MIN	MAX	MIN	MAX	MIN	MAX	MIN	MAX	Millimeters	MIN	MAX	MIN	MAX	MIN	MAX	MIN	MAX
1/4-20	6.25	7.25	8.5	10	8.25	9.5	11	13	M6 x 1.00	6	8	8	11	9	11	12	15
1/4-28	8	9	11	12	10.5	12	14	16	M8 x 1.25	16	20	21.5	27	23	27	31	36.5
5/16-18	14	15	19	20	18.5	20	25	27	M10 x 1.50	29	35	39	47	42	52	57	70
5/16-24	17.5	19	23	26	23	25	31	34	M12 x 1.75	52	62	70	84	75	91	102	123
3/8-16	26	28	35	38	35	37	47.5	50	M14 x 2.00	85	103	115	139	120	146	163	198
3/8-24	31	34	42	46	41	45	55.5	61	M16 x 2.50	130	158	176	214	176	216	238	293
7/16-14	41	45	55.5	61	55	60	74.5	81	M18 x 2.50	172	210	233	284	240	294	325	398
7/16-20	51	55	69	74.5	68	75	92	102	M20 x 2.50	247	301	335	408	343	426	465	577
1/2-13	65	72	88	97.5	86	96	116	130	M22 x 2.50	332	404	450	547	472	576	639	780
1/2-20	76	84	103	114	102	112	138	152	M24 x 3.00	423	517	573	700	599	732	812	992
9/16-12	95	105	129	142	127	140	172	190	M27 x 3.00	637	779	863	1055	898	1098	1217	1488
9/16-18	111	123	150	167	148	164	200	222	M30 x 3.00	872	1066	1181	1444	1224	1496	1658	2027
5/8-11	126	139	171	188	168	185	228	251									
5/8-18	152	168	206	228	203	224	275	304									
3/4-10	238	262	322	355	318	350	431	474									
3/4-16	274	305	371	409	365	402	495	544									
7/8-9	350	386	474	523	466	515	631	698									
7/8-14	407	448	551	607	543	597	736	809									
1-8	537	592	728	802	716	790	970	1070									
1-14	670	740	908	1003	894	987	1211	1337									

NOTE: These values apply to fasteners as received from supplier, dry or when lubricated with normal engine oil. They do not apply if special graphite or molydisulphide greases or other extreme pressure lubricants are used.

O-Ring Face Seal Hose/ Tube Swivel Nut

Metric Tube O.D. (mm)	Dash Size	Thread Size (in.)	Swivel Nut Hex Size (in.)	Swivel Nut Torque	
				N-m	lb.ft
5	-3	--	--	--	--
6	-4	9/16 - 18	11/16	16	12
8	-5	--	--	--	--
10	-6	11/16 - 16	13/16	24	18
12	-8	13/16 - 16	15/16	50	37
16	-10	1 - 14	1-1/8	69	51
20	-12	1-3/16 - 12	1-3/8	102	75
22	-14	1-3/16 - 12	--	102	75
25	-16	1-7/16 - 12	1-5/8	142	105
32	-20	1-11/16 - 12	1-7/8	190	140
38	-24	2 - 12	2-1/4	217	160
50.8	-32	--	--	--	--

Torque Specifications for SAE O-Ring Fittings

Size	Swivel Nut or Hose	Assembly Torque		
		in.-lb.	ft.-lb.	F.F.F.T.
2	5/16-24	90 ± 5	7.5 ± 0.5	1 ± .25
3	3/8-24	170 ± 10	14 ± 1	1 ± .25
4	7/16-20	220 ± 15	18 ± 1	1 ± .25
5	1/2-20	260 ± 15	22 ± 1	1 ± .25
6	9/16-18	320 ± 20	27 ± 2	1.5 ± .25
8	3/4-16	570 ± 25	48 ± 2	1.5 ± .25
10	7/8-14	1060 ± 50	90 ± 5	1.5 ± .25
12	1 1/16-12	1300 ± 50	110 ± 5	1.5 ± .25
14	1 3/16-12	1750 ± 75	145 ± 6	1.5 ± .25
16	1 5/16-12	1920 ± 125	160 ± 6	1.5 ± .25
20	1 5/8-12	2700 ± 150	225 ± 12	1.5 ± .25
24	1 7/8-12	3000 ± 150	250 ± 12	1.5 ± .25
32	2 1/2-12	3900 ± 200	325 ± 15	1.5 ± .25

Torque Specifications for 37° JIC Fittings

Size	Thread Size	Assembly Torque		Tube Connection F.F.F.T	Swivel Nut or Hose Connection F.F.F.T
		in.-lb.	ft.-lb.		
-4	7/16-20	140 ± 10	12 ± 1	2	2
-5	1/2-20	180 ± 15	15 ± 1	2	2
-6	9/16-18	250 ± 15	21 ± 1	1 1/2	1 1/4
-8	3/4-16	550 ± 25	45 ± 5	1 1/2	1
-12	1 1/16-12	1000 ± 50	85 ± 5	1 1/4	1
-16	1 5/16-12	1450 ± 50	120 ± 5	1	1
-20	1 5/8-12	2000 ± 100	170 ± 10	1	1
-24	1 7/8-12	2400 ± 150	200 ± 15	1	1
-32	2 1/2-12	3200 ± 200	270 ± 20	1	1

RHINO LIMITED WARRANTY

1. LIMITED WARRANTIES

- 1.01. Rhino warrants for one year from the purchase date to the original non-commercial, governmental, or municipal purchaser ("Purchaser") and warrants for six months to the original commercial or industrial purchaser ("Purchaser") that the goods purchased are free from defects in material or workmanship.
- 1.02. Manufacturer will replace for the Purchaser any part or parts found, upon examination at one of its factories, to be defective under normal use and service due to defects in material or workmanship.
- 1.03. This limited warranty does not apply to any part of the goods which has been subjected to improper or abnormal use, negligence, alteration, modification, or accident, damaged due to lack of maintenance or use of wrong fuel, oil, or lubricants, or which has served its normal life. This limited warranty does not apply to any part of any internal combustion engine, or expendable items such as blades, shields, guards, or pneumatic tires except as specifically found in your Operator's Manual.
- 1.04. Except as provided herein, no employee, agent, Dealer, or other person is authorized to give any warranties of any nature on behalf of Manufacturer.

2. REMEDIES AND PROCEDURES.

- 2.01. This limited warranty is not effective unless the Purchaser returns the Registration and Warranty Form to Manufacturer within 30 days of purchase.
- 2.02. Purchaser claims must be made in writing to the Authorized Dealer ("Dealer") from whom Purchaser purchased the goods or an approved Authorized Dealer ("Dealer") within 30 days after Purchaser learns of the facts on which the claim is based.
- 2.03. Purchaser is responsible for returning the goods in question to the Dealer.
- 2.04. If after examining the goods and/or parts in question, Manufacturer finds them to be defective under normal use and service due to defects in material or workmanship, Manufacturer will:
 - (a) Repair or replace the defective goods or part(s) or
 - (b) Reimburse Purchaser for the cost of the part(s) and reasonable labor charges (as determined by Manufacturer) if Purchaser paid for the repair and/or replacement prior to the final determination of applicability of the warranty by Manufacturer.The choice of remedy shall belong to Manufacturer.
- 2.05. Purchaser is responsible for any labor charges exceeding a reasonable amount as determined by Manufacturer and for returning the goods to the Dealer, whether or not the claim is approved. Purchaser is responsible for the transportation cost for the goods or part(s) from the Dealer to the designated factory.

3. LIMITATION OF LIABILITY.

- 3.01. MANUFACTURER DISCLAIMS ANY EXPRESS (EXCEPT AS SET FORTH HEREIN) AND IMPLIED WARRANTIES WITH RESPECT TO THE GOODS INCLUDING, BUT NOT LIMITED TO, MERCHANTABILITY AND FITNESS FOR A PARTICULAR PURPOSE.
- 3.02. MANUFACTURER MAKES NO WARRANTY AS TO THE DESIGN, CAPABILITY, CAPACITY, OR SUITABILITY FOR USE OF THE GOODS.
- 3.03. EXCEPT AS PROVIDED HEREIN, MANUFACTURER SHALL HAVE NO LIABILITY OR RESPONSIBILITY TO PURCHASER OR ANY OTHER PERSON OR ENTITY WITH RESPECT TO ANY LIABILITY, LOSS, OR DAMAGE CAUSED OR ALLEGED TO BE CAUSED DIRECTLY OR INDIRECTLY BY THE GOODS INCLUDING, BUT NOT LIMITED TO, ANY INDIRECT, SPECIAL, CONSEQUENTIAL, OR INCIDENTAL DAMAGES RESULTING FROM THE USE OR OPERATION OF THE GOODS OR ANY BREACH OF THIS WARRANTY. NOTWITHSTANDING THE ABOVE LIMITATIONS AND WARRANTIES, MANUFACTURERS LIABILITY HEREUNDER FOR DAMAGES INCURRED BY PURCHASER OR OTHERS SHALL NOT EXCEED THE PRICE OF THE GOODS.
- 3.04. NO ACTION ARISING OUT OF ANY CLAIMED BREACH OF THIS WARRANTY OR TRANSACTIONS UNDER THIS WARRANTY MAY BE BROUGHT MORE THAN TWO (2) YEARS AFTER THE CAUSE OF ACTION HAS OCCURRED.

4. MISCELLANEOUS.

- 4.01. Proper Venue for any lawsuits arising from or related to this limited warranty shall be only in Guadalupe County, Texas.
- 4.02. Manufacturer may waive compliance with any of the terms of this limited warranty, but no waiver of any terms shall be deemed to be a waiver of any other term.
- 4.03. If any provision of this limited warranty shall violate any applicable law and is held to be unenforceable, then the invalidity of such provision shall not invalidate any other provisions herein.
- 4.04. Applicable law may provide rights and benefits to purchaser in addition to those provided herein.

KEEP FOR YOUR RECORDS

ATTENTION: Purchaser should fill in the blanks below for his reference when buying repair parts and/or for proper machine identification when applying for warranty.

Rhino Implement Model _____ Serial Number _____
Date Purchased _____ Dealer _____

ATTENTION:
READ YOUR OPERATORS MANUAL

RHINO
Member of the Alamo Group
1020 S. Sangamon Ave.
Gibson City, IL 60936
800-446-5158





TO THE OWNER/OPERATOR/DEALER

In addition to the standard Limited Warranty shown on the facing page, Rhino also provides:

1. A TWO-YEAR (24 months) LIMITED WARRANTY* on non-perishable structural items such as: Loader Boom, Side Frames, Mount Brackets, Backhoe Boom, Dipper, Main Frame, Stabilizer Legs, Swing Bracket, Subframe and Related Mounting Brackets provided they have not been subjected to abuse or misuse and have been properly maintained as noted.

NOTE – “properly maintained” specifically includes, but is not limited to:

- A) Regular lubrication.
- B) Using proper amounts of correct hydraulic fluid.
- C) Regular torque inspection of all fasteners.

2. *WARRANTY LIMITATIONS – Warranty is ONE-YEAR (12 months) for hydraulic cylinders and seals, pivot pins, wear bushings, hydraulic hoses, buckets or other attachments, wear or cutting edges and tooth bars. After one year (12 months) standard warranty, these items are considered “Wearing Perishable Parts” and replacement is the users’ responsibility.



TO THE OWNER/OPERATOR/DEALER

To keep your implement running efficiently and safely, read your manual thoroughly and follow these directions and the Safety Messages in this Manual. The Table of Contents clearly identifies each section where you can easily find the information you need.

The OCCUPATIONAL SAFETY AND HEALTH ACT (1928.51 Subpart C) makes these minimum safety requirements of tractor operators:

REQUIRED OF THE OWNER:

1. Provide a Roll-Over-Protective Structure that meets the requirements of this Standard; and
2. Provide Seatbelts that meet the requirements of this paragraph of this Standard and SAE J4C; and
3. Ensure that each employee uses such Seatbelt while the tractor is moving; and
4. Ensure that each employee tightens the Seatbelt sufficiently to confine the employee to the protected area provided by the ROPS.

REQUIRED OF THE OPERATOR

1. Securely fasten seatbelt if the tractor has a ROPS.
2. Where possible, avoid operating the tractor near ditches, embankments, and holes.
3. Reduce speed when turning, crossing slopes, and on rough, slick, or muddy surfaces.
4. Stay off slopes too steep for safe operation.
5. Watch where you are going -especially at row ends, on roads, and around trees.
6. Do not permit others to ride.
7. Operate the tractor smoothly -no jerky turns, starts, or stops.
8. Hitch only to the drawbar and hitch points recommended by the tractor manufacturer.
9. When the tractor is stopped, set brakes securely and use park lock, if available.

Keep children away from danger all day, every day...

Equip tractors with rollover protection (ROPS) and keep all machinery guards in place...

Please work, drive, play and live each day with care and concern for your safety and that of your family and fellow citizens



Free Manuals Download Website

<http://myh66.com>

<http://usermanuals.us>

<http://www.somanuals.com>

<http://www.4manuals.cc>

<http://www.manual-lib.com>

<http://www.404manual.com>

<http://www.luxmanual.com>

<http://aubethermostatmanual.com>

Golf course search by state

<http://golfingnear.com>

Email search by domain

<http://emailbydomain.com>

Auto manuals search

<http://auto.somanuals.com>

TV manuals search

<http://tv.somanuals.com>