



ALPHASONIK®

Owner's Manual

CLASS A/B BIPOLAR POWER AMPLIFIERS

**PM3002E / PM6002E
PM6004E / PM12005E / PM1600DE**

ALPHASONIK WAS FOUNDED IN 1976 WITH ONE MISSION, TO BRING STATE OF THE ART PERFORMANCE TO THE CAR AUDIO ENTHUSIAST.

In those early years we pioneered such ground-breaking technologies as amplifier fan cooling and high voltage signal transfer which remain a benchmark in high-end audio.

Today, the new Alphasonik is committed to pushing the envelope with regard to technology, quality and value. Our electronics feature audiophile parts and circuit topology designed to let the full musical experience come through, loud and clear. Our loudspeakers employ the latest high technology materials and processes such as carbon reinforced woven glass and titanium vapor deposition to deliver your music with tremendous impact, dynamics and resolution.

We stand behind our quality with one of the best warranties in consumer electronics. Compare Alphasonik car audio products against anything competition has to offer. We're confident you will come to one conclusion...



Introduction.....3

Features and Specifications.....4-5

Planning & Mounting Your System.....6

Controls & Functions.....7-14

High Level Input.....15-16

Wiring Diagrams.....17-22

Adjusting & Tuning.....23

Troubleshooting.....24

Warning / Disclaimer.....25

Warranty.....26-27

Notes.....28-30

Thank you for purchasing this Alphasonik product. Alphasonik products are specifically engineered and designed for the mobile audio environment. This manual contains important information about installation, set-up procedures and integrating your new Alphasonik product into your vehicle. With proper care and installation, your new product will provide you with many years of high performance listening enjoyment. We recommend having an Authorized Alphasonik Dealer install your new product for optimal performance and to take advantage of our warranty program. Before installing your new product, please read through the manual to fully understand the application.

Before making any electrical connections, make sure that you disconnect the battery's ground cable to prevent the possibility of short circuits or damage to your electronic equipment. If your vehicle's stereo (head unit) comes with an Anti-theft code, DO NOT disconnect the battery. If you have the access code for the stereo (head unit), please refer to the vehicle's owner's manual.

Class A/B BIPOLAR Power Amplifier

2 Ohm Stable (PM3002E / 6002E / 6004E / 12005E)

Mosfet High Speed Switching Supply

Tiffany-Style Input and Output RCA Jacks

RCA (Low Level) and Speaker (High Level)Inputs

Line Out

Bridgeable

Variable High Pass Filter: 50Hz-250Hz

Variable Low Pass Filter: 50Hz-250Hz

Variable Subsonic Filter: 20Hz-60Hz

Bass Boost Control: 45Hz 0 - +18dB

Remote Digital Voltmeter (PMA100VE)- Optional

Remote Bass Control (PMA10BE)-Optional

Remote Power On / Off By Car Stereo

Input Sensitivity: High 1V / 10V / Low 200mV - 8V

4-Way Protection Circuitry: Thermal, Short Circuit, Overload And DC Offset

MODEL:	PM3002E	PM6002E	PM6004E	PM12005E	PM1600DE
Power /4 Ohms	75 X 2	150 X 2	75 X4	75 X 4 & 200 X 1	300 X 1
Power /2 Ohms	120 X 2	240 X 2	120 X 4	120 X 4 & 320 X 1	600 X 1
Power /1 Ohm	N/A	N/A	N/A	N/A	N/A
T.H.D.	0.05%	0.05%	0.05%	0.05%	
Signal to Noise Ratio	>98db	>98db	>98db	>95db	
Damping Factor	>175	>250	>175	>250	
Separation	63db	69db	60db	60db	
Input Sensitivity	200mV-8V	200mV-8V	200mV-8V	200mV-8V	200mV-8V
Input Impedance	10Kohms	10Kohms	10Kohms	10K ohms	10Kohms
Power Fuse	20 Amp	(2)20 Amp	(2)20 Amp	(2)40 Amp	(2)30 Amp
Dimensions					
Length	8 1/16"	11 7/8"	12 5/8"	18 15/16"	6 1/2"
Height	2"	2"	2"	2"	2"
Width	9 1/4"	9 1/4"	9 1/4"	9 1/4"	9 1/4"
Crossover	Selectable ON/OFF Crossover-Fully Variable 50Hz-250Hz / 18 db/Octave				
Variable Low Pass	50Hz-250Hz	50Hz-250Hz	50Hz-250Hz	50Hz-250Hz	50Hz-250Hz
Variable High Pass	50Hz-250Hz	50Hz-250Hz	50Hz-250Hz	50Hz-250Hz	N/A
Variable Subsonic Filter	20Hz - 60Hz	20Hz - 60Hz	20Hz - 60Hz	20Hz - 60Hz	20Hz - 60Hz
Variable Bass Boost at 45Hz	0~+18db	0~+18db	0~+18db	0~+18db	0~+18db

Before beginning the installation, consider the following:

- A. If you plan to expand your system by adding other components sometimes in the future, ensure that adequate is left, and cooling requirements are met.
- B. Are your components matched? The peak power rating of your speakers must be equal or greater than the amplifier's. They also must be 2-8 ohms impedance (This information is normally printed on the speaker magnet).
- C. Consider the length of your leads which should not be too long or short when determining the mounting location. Pre-Amp input jacks require a length of high quality shielded male to male RCA patch cord.

Mounting Your Amplifier

The mounting position of your amplifier will have a greater affect on its ability to dissipate the heat generated during normal operation. This amplifier has ample heat sink for heat dissipation, and is designed with a thermal shutdown circuit (for heat protection). **DO NOT** enclose the amplifier in a small box or cover it so that air is not able to flow freely.

Temperatures in car trunks have been measured as high as (155 F) in the summer time. As the thermal shut down point for the amplifier is (185 F), it is easy to see that it must be mounted in an area that provides for maximum cooling capability. To achieve maximum advantage of convection air flow in an enclosed trunk, mount the amplifier in a horizontal position.

Cooling requirements are considerably relaxed when the mounting inside the passenger compartment since the driver compartment will not allow temperatures to reach a critical point. Floor mounting under the seat is usually satisfactory as long as there is at least 1 inch of clearance above the amplifier's heat sink for ventilation.

- A. Select a suitable location that is convenient for mounting, is accessible for wiring, and has ample room for air circulation and cooling.
- B. Use the amplifier as a template to mark the mounting holes. Remove the amplifier and drill holes. Use extreme caution, inspect underneath surface before drilling!
- C. Secure the amplifier using the screws provided.

Caution: Before connecting any wires to the amplifier, disconnect the ground lead from the battery. Leave the ground lead disconnected until you are done wiring the amplifier.

PM3002E / PM6002E / PM1600DE

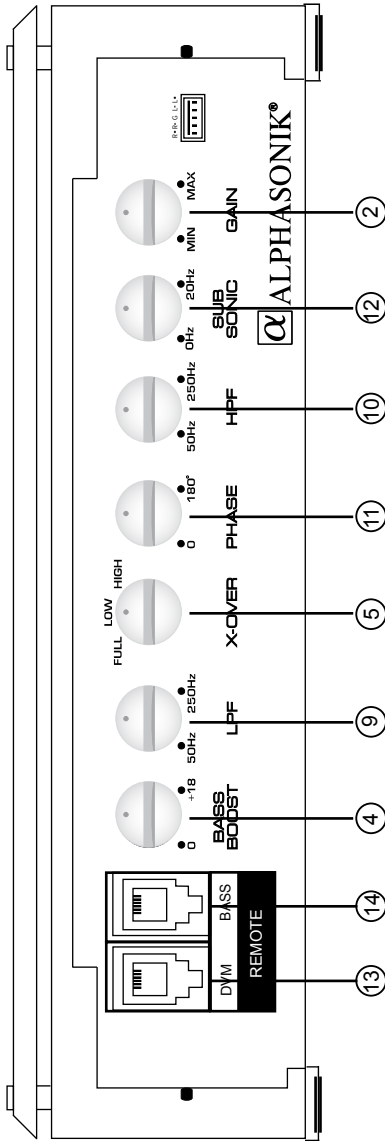

PM3002 / PM6002E / PM1600DE

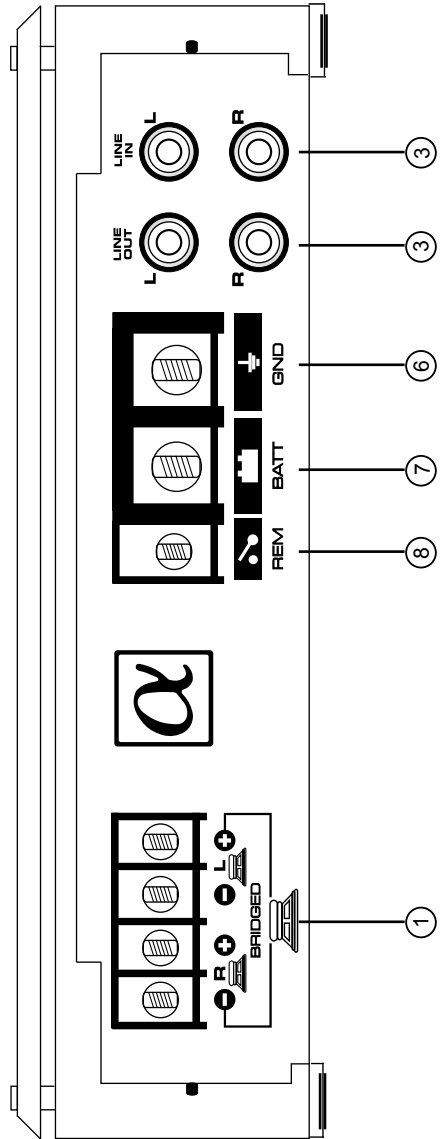

PM6004E

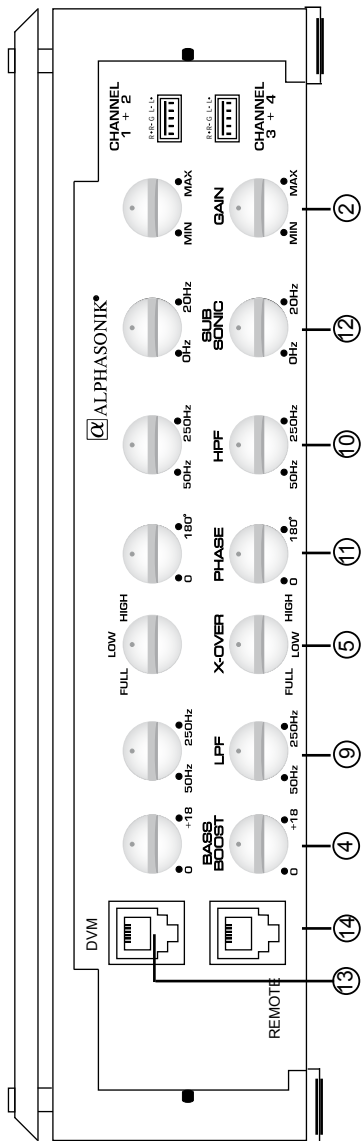

PM6004E

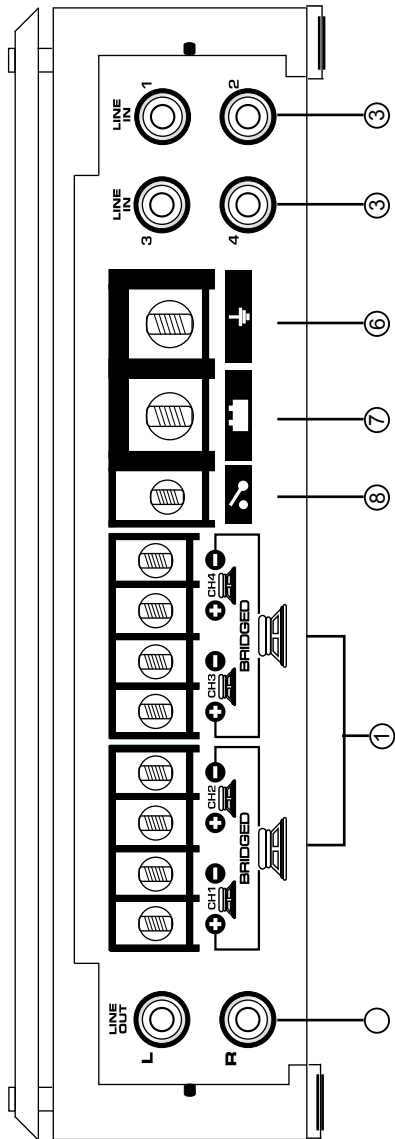

PM12005E

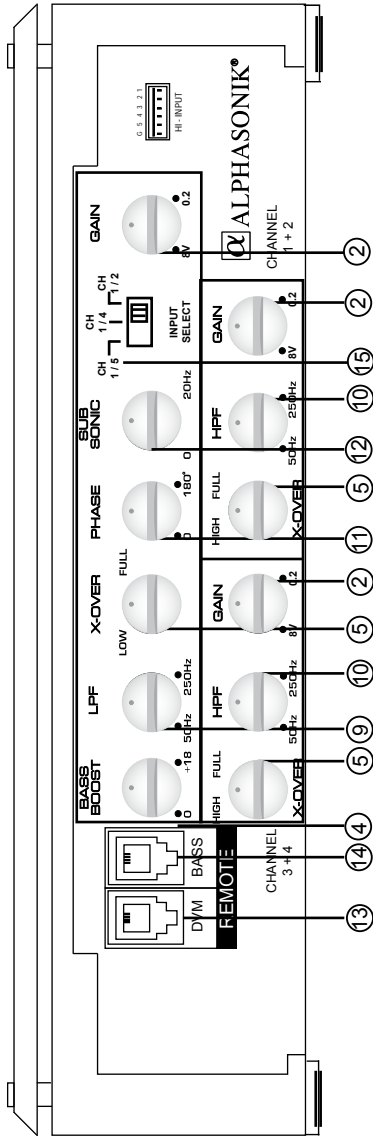

PM12005E

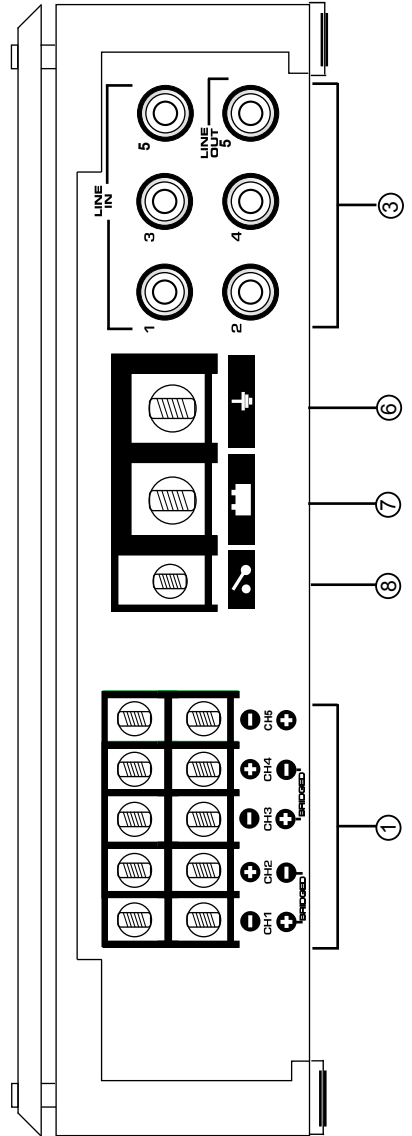

1. SPEAKER TERMINALS

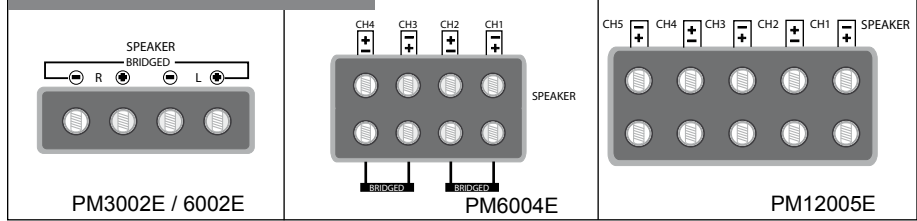

2. INPUT SENSITIVITY ADJUSTMENT

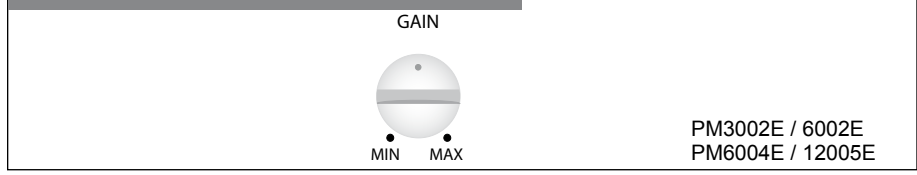

This control adjusts the amplifier's input sensitivity. Input sensitivity is variable from 200 Mil volts to 8 volts. Clockwise increases sensitivity. Counterclockwise decreases sensitivity. This knob is not a volume control for the amplifier. The amplifier can be driven to full power with a wide range of signal levels. A lower signal level will require increased sensitivity for full power. A higher signal level will require decreased sensitivity.

3. LOW LEVEL INPUT & OUTPUT RCA JACKS

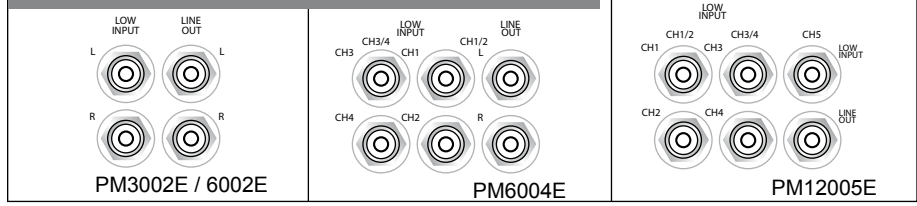

These inputs are signal cables from the source. Always use high quality shielded RCA cables.

The LINE OUT allows you to build multiple amplifier systems without having to use splitter cords to distribute the signal. Now it is a matter of bringing one set of RCA'S into the first amplifier, then using the LINE OUT RCA jacks as the feed to the next amplifier.

4. BASS BOOST CONTROL

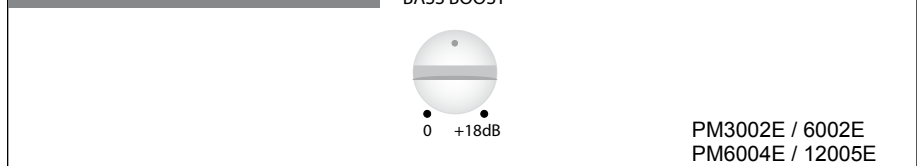

By using the BASS BOOST function, bass notes at 45Hz are emphasized as much as 18db.

5. CROSSOVER SWITCH

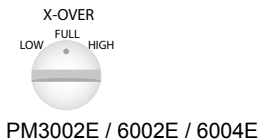

5 CHANNEL

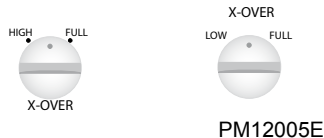

Adjust the crossover for your chosen installation method.

- LOW: Low pass filter-only bass tones (50Hz – 250Hz) go to speakers. Use with or sub-woofer
- FULL: No filter-all tones go to speakers. Use with full-range speakers, or with external crossovers.
- HIGH: High pass filter-blocks very low tones (50Hz – 250Hz) from the speakers.

6. B-TERMINAL (CHASSIS GROUND)

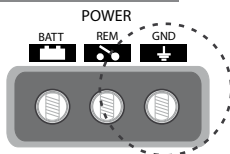

PM3002E / 6002E
PM6004E / 12005E

To avoid unwanted ignition noise caused by ground loops, it is essential that the amplifier be grounded to a clean, bare, metal surface of the vehicle's chassis.

Note: GROUND WIRE SHOULD NOT BE EXTENDED MORE 3' 6".

7. B+TERMINAL (BATTERY POSITIVE)

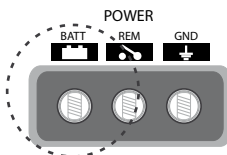

PM3002E / 6002E
PM6004E / 12005E

Due to the power requirements of the amplifier, this connection should be made directly to the positive (+) terminal of the battery. For safety measures install an in-line fuse holder (not included) as close to the battery positive (+) terminal as possible with an ampere rating not to exceed the value of the fuses in Amplifier.

8. REMOTE TURN-ON INPUT

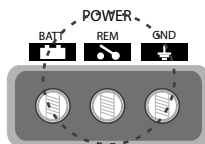

PM3002E / 6002E
PM6004E / 12005E

To the car stereo remote turn on wire.

This amplifier is turned "ON" remotely when the vehicle's stereo is turned "ON"

Note: IF YOUR RADIO DOES NOT HAVE A +12 VOLT OUTPUT LEAD WHEN THE RADIO IS TURNED ON, THE "REMOTE" TERMINAL ON THE AMPLIFIER CAN BE CONNECTED TO THE VEHICLE'S ACCESSORY CIRCUIT THAT IS LIVE WHEN THE KEY IS "ON".

9. LOW PASS FILTER CONTROL



PM3002E / 6002E
PM6004E / 12005E

Variable Low-Pass filter (50Hz – 250Hz): For use as a dedicated subwoofer channel, set filter switch to “LPF”. Adjust variable crossover frequency with control as desired. The amplifier input circuit filters out everything above 50Hz.....250Hz (dependent on the adjustment of the frequency control), so only the deepest bass notes are amplified.

10. HIGH PASS FILTER CONTROL



PM3002E / 6002E
PM6004E / 12005E

Variable High-Pass Filter (50Hz – 250Hz): For use as a dedicated mid high range channel, set filter switch to “HPF”. The input out all frequencies below 50Hz.....250Hz.

11. PHASE SHIFT CONTROLS



PM3002E / 6002E
PM6004E / 12005E

PHASE SHIFT SWITCH (0 AND 180 DEGREES): allows you to change the phase of your subwoofer from 0 to 180 degrees to help compensate for timing difference between drivers

12. SUBSONIC CONTROLS

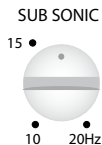

PM3002E / 6002E
PM6004E / 12005E

SUBSONIC Variable: 15Hz-60Hz

13. DVM REMOTE CONTROL

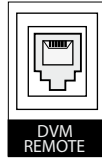

PM3002E / 6002E
PM6004E / 12005E

14. BASS REMOTE CONTROL



PM3002E / 6002E
PM6004E / 12005E

15. INPUT SELECT SWITCH

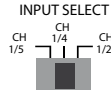

PM12005E

SWITCH POSITION	INPUT	OUTPUT
<p>1/2 Position</p>	<p>INPUT</p>	<p>OUTPUT</p>
<p>1/4 Position</p>	<p>INPUT</p>	<p>OUTPUT</p>
<p>1/5 Position</p>	<p>INPUT</p>	<p>OUTPUT</p>

13. DVM REMOTE CONTROL

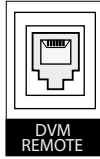

PM3002E / 6002E
PM6004E / 12005E

14. BASS REMOTE CONTROL



PM3002E / 6002E
PM6004E / 12005E

15. INPUT SELECT SWITCH

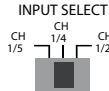

PM12005E

SWITCH POSITION	INPUT	OUTPUT
<p>1/2 Position</p>		
<p>1/4 Position</p>		
<p>1/5 Position</p>		

If the HIGH LEVEL INPUTS are used, do not use the LOW LEVEL RCA inputs at the same time.

PM3002E / 6002E

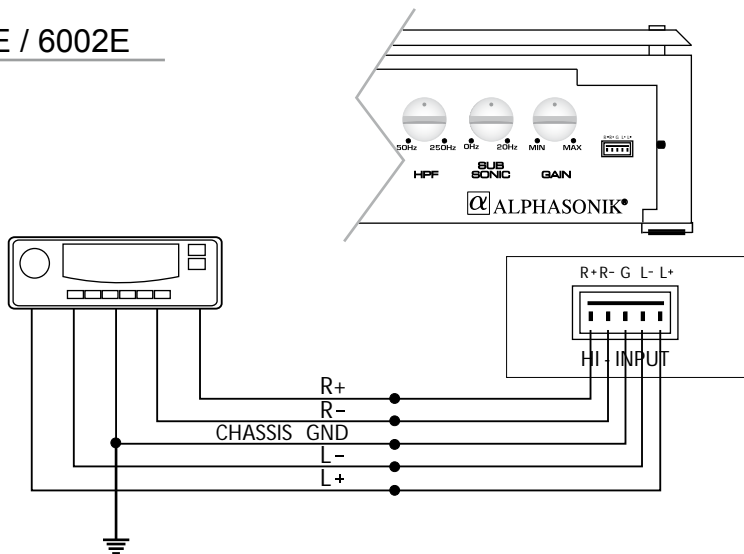

PM6004E

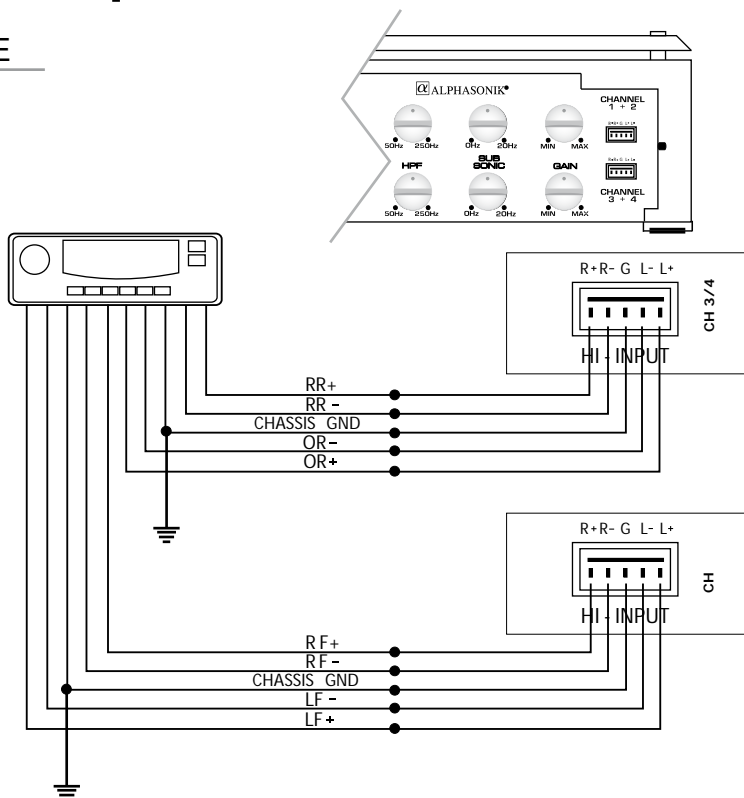

If the HIGH LEVEL INPUTS are used, do not use the LOW LEVEL RCA inputs at the same time.

PM12005E

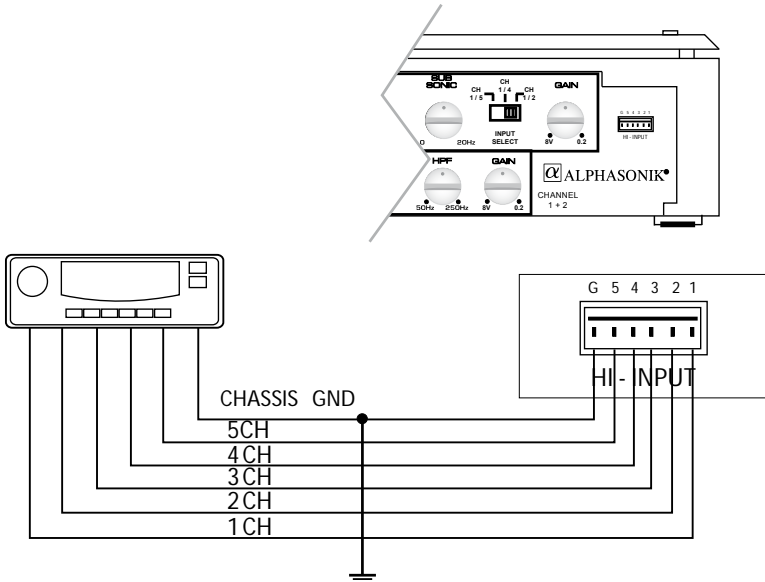

PM3002E / 6002E

MONO MODE

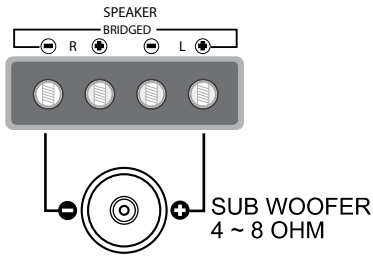

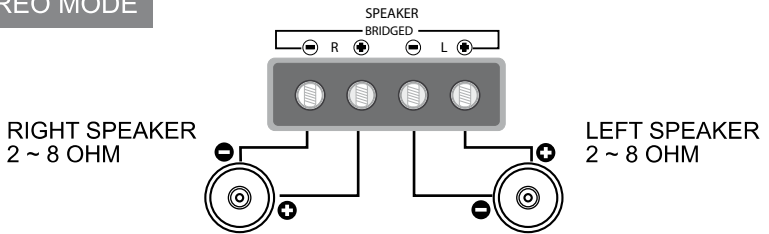

STEREO MODE

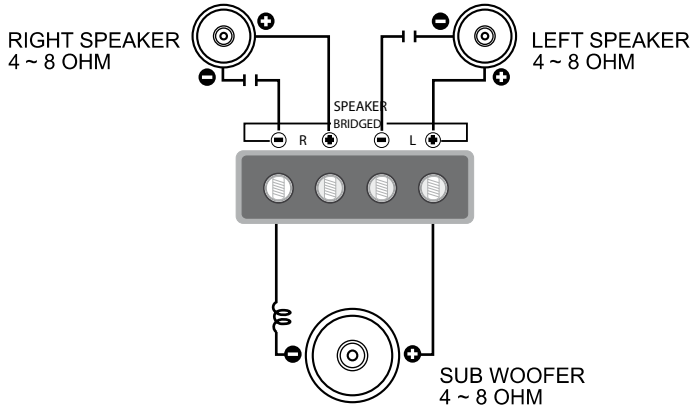

PM3002E / 6002E

TRI MODE



 : INDUCTOR LOW PASS FILTER
 : CAPACITOR HIGH PASS FILTER

TRI MODE OPERATIONAL OUTPUT allows a Speaker to be operated in MONO mode while the main speakers are playing in stereo. Leave the Crossover (Sub-woofer) switch on "FULL" position. Use a 100 Volt, non polarized capacitor for a high pass crossover and wire coil (inductor) to block high frequencies from the (Sub) Woofer as shown in the figure below. Capacitor and inductor values as written in the section below determine crossover frequencies.

COMPONENT VALUES FOR 6 dB PASSIVE CROSSOVER

FREQUENCY	INDUCTOR	CAPACITOR
80 Hz	7.5 mH	470 uF
100 Hz	6.5 mH	330 uF
120 Hz	5.5 mH	330 uF
150 Hz	4 mH	220 uF

PM6004E

MONO MODE

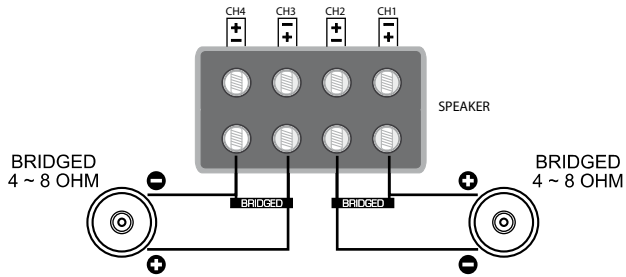

3 CHANNEL MODE

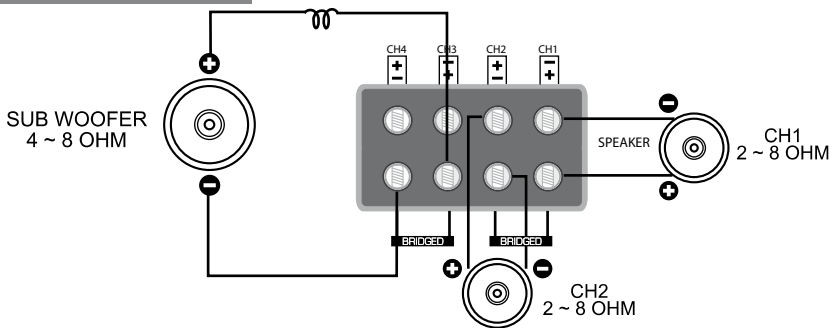

4 CHANNEL MODE

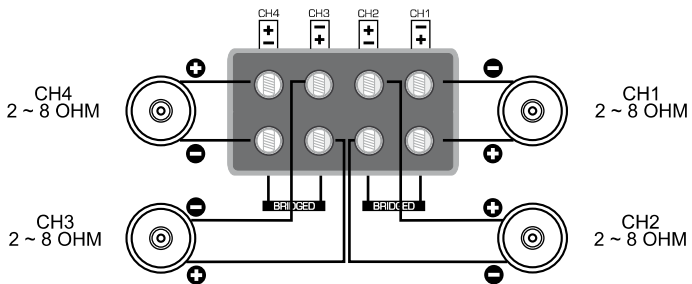



 : INDUCTOR LOW PASS FILTER

PM6004E

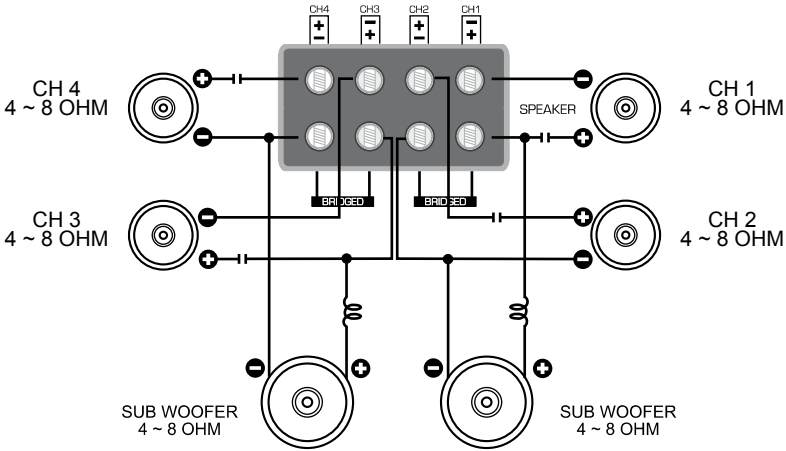
6 CHANNEL MODE



 : INDUCTOR LOW PASS FILTER
 : CAPACITOR HIGH PASS FILTER

COMPONENT VALUES FOR 6 dB PASSIVE CROSSOVER

FREQUENCY	INDUCTOR	CAPACITOR
80 Hz	7.5 mH	470 uF
100 Hz	6.5 mH	330 uF
120 Hz	5.5 mH	330 uF
150 Hz	4 mH	220 uF

PM12005E

3 CHANNEL MODE

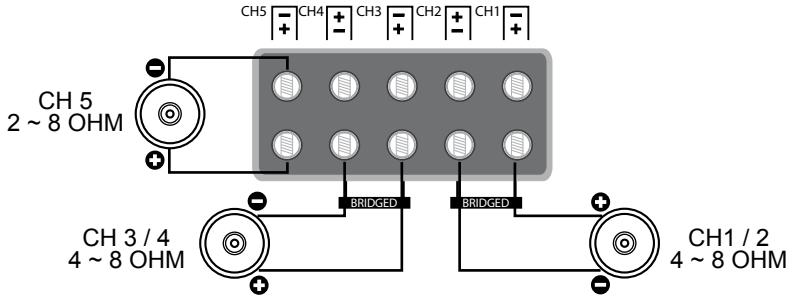

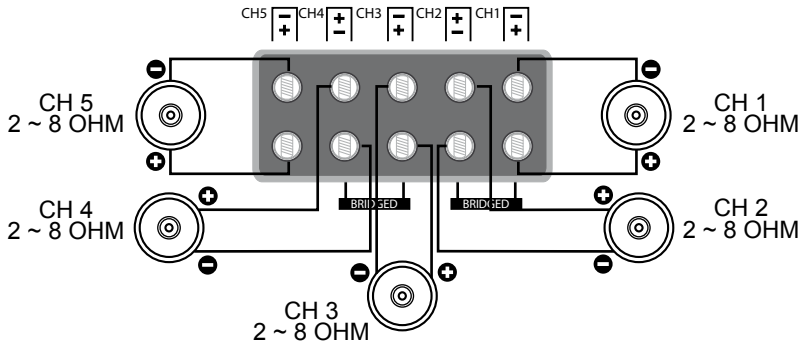

5 CHANNEL MODE

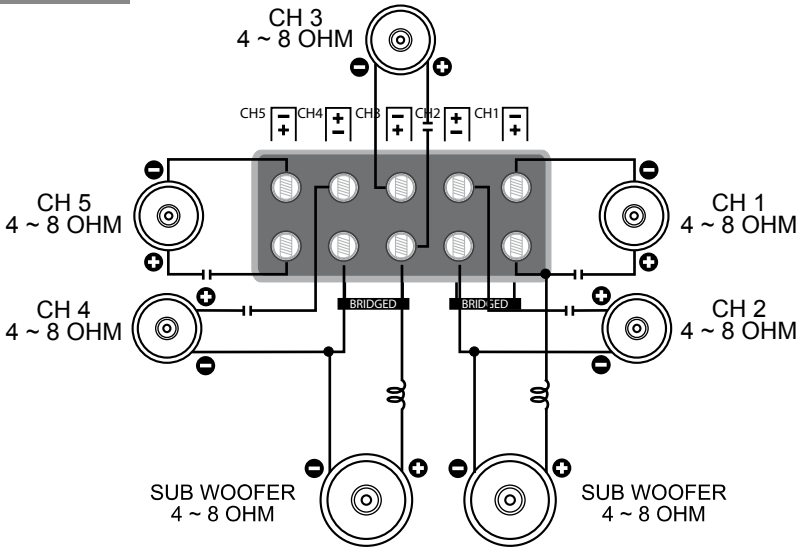

PM12005E

TRI MODE



 : INDUCTOR LOW PASS FILTER
 -  : CAPACITOR HIGH PASS FILTER

COMPONENT VALUE FOR 6 dB PASSIVE CROSSOVER

FREQUENCY	INDUCTOR	CAPACITOR
80 Hz	7.5 mH	470 uF
100 Hz	6.5 mH	330 uF
120 Hz	5.5 mH	330 uF
150 Hz	4 mH	220 uF

Turning On The Amplifier

The amplifier automatically turns on a few seconds after you turn vehicle's ignition switch to ACC ON or turn on your auto sound system, depending upon how you wired the system. The POWER indicator on the top of the amplifier illuminates when the amplifier is on.

Important: Your amplifier requires 90 amps or more of power from your vehicle's battery during operation. To protect your battery from your battery from discharging, do not operate the amplifier unless your vehicle is running.

Adjusting The Audio Level ("Gain Matching") By Ear

For best performance, you must match the amplifier's input sensitivity to your source unit's maximum output level. The GAIN CONTROL (MIN / MAX) located on the side of the amplifier is designed to do this. It is Not a volume control. It adjusts the incoming signal level so that the source unit and amplifier reach maximum output at the same time. This assures that maximum system is achieved with minimal distortion.

1. Turn the GAIN CONTROL (MIN / MAX) fully counterclockwise to MIN.
2. Play full frequency music that has continuous high levels (FM pop music is a good choice).
3. Turn up the source unit's volume control until just before you hear the source unit's distortion or 90% of full output (which ever comes first).
4. SLOWLY turn the GAIN CONTROL clockwise until just before you hear amplifier or speaker distortion, until you reach a maximum comfortable listening level (which ever come first).
5. Turn the source unit's volume control back to a desire comfortable listening level and enjoy.

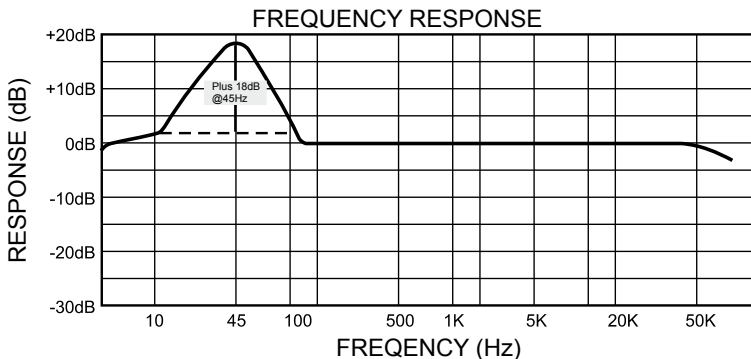

The BASS BOOST CONTROL raises the amplifier output up to 18db at frequencies tightly centered around 45 Hz. This "bump" can have a dramatic effect on the bass system's apparent volume. Use caution (!) when adjusting this control as serious subwoofer damage may result from overpowering or overexcursion.

SYMPTOMS	CHECK	REMEDY
NO SOUND	Is the power LED illuminator? (NO)	Check all fuses to amplifier. Be sure Turn-on lead is connected. Check signal leads. Check gain control. Check tuner/deck volume level. Clean contacts on fuse holders
	Is the Diagnostic LED illuminated? (YES)	Check for speakers short or amplifier overheating
AMP. NOT SWITCHING ON	No power to power wire	Repair power wire or connections
	No power to remote wire with receiver on	Check connections to radio
	Burnt or broken fuse	Replace fuse
NO SOUND IN ONE CHANNEL	Check Speakers Leads	Inspect for short circuit or an open connection
	Check Audio Leads	Reverse Left Right RCA inputs to determine if the problem is occurring before the amp.
AMP. TURNING OFF MEDIUM / HIGH VOLUME	Check Speaker Load Impedance	Be sure proper speaker load impedance recommendations are observed. (If you use an ohmmeter that DC resistance and AC impedance may not be the same).
PROTECTION LAMP ON	Shut down	Turn radio down, wait for amp. To cool
	Speaker wires shorted	Separate speaker wires and insulate

Investigate the layout of your vehicle thoroughly before drilling or cutting. Take care when you work near the gas tank, gas lines, hydraulic lines, electrical components and electrical wiring. Do not use the equipment unmounted. Attach this system securely to prevent damage, particularly in the event of an accident or aggressive driving. Do not mount the system so that wire connections are unprotected or are subjected to pinching or damage from nearby objects. Before connecting or disconnecting power connections at the system power terminals, disconnect the +12V DC wire at the battery end. Confirm that your source unit and other equipment are turned off while connecting the input terminals. If you need to replace the power fuse, replace it only with a fuse identical to the provided fuse. Using a fuse of different type or rating may result in damage to the system, which is not covered by the manufacturer's warranty. Do not install any product where it may be subjected to excessive heat, moisture and dust or where it may be repeatedly kicked, brushed or bumped. Make absolutely sure that the terminals for the products are connected to the proper inputs and outputs from the music source. Never run the wiring on the outside of the vehicle or under it where it can be damaged by road hazards or any moving parts of the vehicle. Use existing wire channels, sills, panels and molding strips inside the vehicle to hide the wiring for safety and a neat appearance.

DISCLAIMER

IMPORTANT: Never cut any metal that is an integral part of the vehicle's safety or structural support system. If you are unsure, it is best to have the product professionally installed by an Authorized Alphasonik Dealer. Never sacrifice your safety for sound.

Alphasonik, Inc. warrants this product against all defects in material and workmanship for a period of one (1) year from the date of original purchase provided it was purchased from an Authorized Alphasonik, Inc. Dealer.

The conditions of this warranty and the extent of the responsibility of Alphasonik, Inc. under this warranty are as follows:

1. DATED PROOF OF PURCHASE IS REQUIRED FOR WARRANTY SERVICE OF THIS PRODUCT. Information about Alphasonik, Inc. authorized warranty service may also be obtained at www.alphasonikinc.com or by contacting or writing Alphasonik, Inc. at the address listed on the back of this booklet.

2. This warranty will become void if service is performed by any one other than an approved Alphasonik, Inc. Warranty Service Center.

3. This warranty does not apply to any product which has been subjected to misuse, neglect or accident, or which has had the warranty seal broken, serial number altered, defaced or removed, or which has been connected, installed adjusted or repaired other than in accordance with the instructions furnished by Alphasonik, Inc.

4. This warranty does not cover car static, electrical interference, adjustments or labor costs for the removal or reinstallation of the unit for repair.

5. The sole responsibility of Alphasonik, Inc. under this warranty shall be limited to the repair or replacement thereof, at the sole discretion of Alphasonik, Inc.

6. If it becomes necessary to send the product or any defective part to Alphasonik, Inc. or an authorized service station, the product must be shipped in its original or equivalent carton, fully insured, with shipping charges prepaid. Alphasonik, Inc. will not assume any responsibility for any loss or damage incurred in shipping.

7. This warranty is not transferable and protects the original purchaser provided they reside and made their purchase in the United States. International consumers may contact their local retailer or distributor for warranty information.

8. ALL IMPLIED WARRANTIES, EXCEPT TO THE EXTENT PROHIBITED BY APPLICABLE LAW, SHALL HAVE NO GREATER DURATION THAN THE WARRANTY PERIOD SET FORTH ABOVE. UNDER NO CIRCUMSTANCES SHALL ALPHASONIK INC. BE LIABLE FOR ANY LOSS OR DAMAGE, DIRECT OR CONSEQUENTIAL, ARISING OUT OF THE USE OR INABILITY TO USE THE PRODUCT. BECAUSE SOME STATES DO NOT ALLOW LIMITATIONS ON HOW LONG AN IMPLIED WARRANTY LASTS OR EXCLUSIONS OR LIMITATIONS OF INCIDENTAL OR CONSEQUENTIAL DAMAGES, THE ABOVE LIMITATIONS OR EXCLUSIONS MAY NOT APPLY TO YOU.

9. THIS WARRANTY GIVES YOU SPECIFIC LEGAL RIGHTS AND YOU MAY ALSO HAVE OTHER RIGHTS THAT VARY FROM STATE TO STATE.

10. Should you have any difficulties with the performance of this product during warranty or with any Alphasonik, Inc. authorized service center, you may contact the Alphasonik, Inc. National Service Manager at the address listed on the back of the booklet card or call 714.670.8950 for a listing of Authorized Warranty Service Centers in your area.

INSTALLED WARRANTY

(When purchased from and installed by an Authorized Alphasonik, Inc. Dealer)

Speaker and Accessories: 1-year over-the-counter defective exchange plus 1-year repair or replacement at the sole discretion of Alphasonik, Inc.

Electronics: 1-year over-the-counter defective exchange, plus 1-year repair or replacements at the sole discretion of Alphasonik, Inc.

An Alphasonik Extended Warranty Registration Card must be submitted to Alphasonik, Inc. within 30 days of purchase. To process any warranty claim, Alphasonik, Inc. will require the dated proof of purchase, which must specifically show the model and serial number and that installation was provided for the product in question. All other terms per Alphasonik, Inc.'s standard one-year warranty apply.

NOTES



ALPHASONIK®

PROUD MEMBER OF



**ALPHASONIK INC.
7050 VILLAGE DRIVE BLDG. G
BUENA PARK, CALIFORNIA. 90621
TEL: (714)670-8950 · FAX: (714)670-8959**

www.alphasonikinc.com

Download from www.Somanuals.com. All Manuals Search And Download.

Free Manuals Download Website

<http://myh66.com>

<http://usermanuals.us>

<http://www.somanuals.com>

<http://www.4manuals.cc>

<http://www.manual-lib.com>

<http://www.404manual.com>

<http://www.luxmanual.com>

<http://aubethermostatmanual.com>

Golf course search by state

<http://golfingnear.com>

Email search by domain

<http://emailbydomain.com>

Auto manuals search

<http://auto.somanuals.com>

TV manuals search

<http://tv.somanuals.com>