



EN

# TDM-7580E

## AM/FM Cassette Receiver

- **OWNER'S MANUAL**  
Please read before using this equipment.

**ALPINE ELECTRONICS, INC.**  
Tokyo office: 1-1-8 Nishi Gotanda,  
Shinagawa-ku,  
Tokyo 141-8501, Japan  
Tel.: (03) 3494-1101

**ALPINE ELECTRONICS OF AMERICA, INC.**  
19145 Gramercy Place, Torrance,  
California 90501, U.S.A.  
Tel.: 1-800-ALPINE-1 (1-800-257-4631)

**ALPINE ELECTRONICS OF CANADA, INC.**  
Suite 203, 7300 Warden Ave. Markham,  
Ontario L3R 9Z6, Canada  
Tel.: 1-800-ALPINE-1 (1-800-257-4631)

**ALPINE ELECTRONICS OF AUSTRALIA PTY. LTD.**  
6-8 Fiveways Boulevard Keysborough,  
Victoria 3173, Australia  
Tel.: (03) 9769-0000

**ALPINE ELECTRONICS GmbH**  
Kreuzerkamp 7-11 40878 Ratingen, Germany  
Tel.: 02102-45 50

**ALPINE ITALIA S.p.A.**  
Via C. Colombo 8, 20090 Trezzano Sul Naviglio  
MI, Italy  
Tel.: 02-48 47 81

**ALPINE ELECTRONICS FRANCE S.A.R.L.**  
(RCS PONTOISE B 338 101 280)  
98, Rue De La Belle Etoile, Z.I. Paris Nord II  
B.P. 50016 F-95945, Roissy, Charles De Gaulle  
Cedex, France  
Tel.: 01-48 63 89 89

**ALPINE ELECTRONICS OF U.K., LTD.**  
13 Tanners Drive, Blakelands, Milton Keynes  
MK14 5BU, U.K.  
Tel.: 01908-61 15 56

**ALPINE ELECTRONICS DE ESPAÑA, S.A.**  
Portal De Gamarra 36, Pabellón 32  
01013 Vitoria (Alava)-Apdo. 133, Spain  
Tel.: 34-45-283588

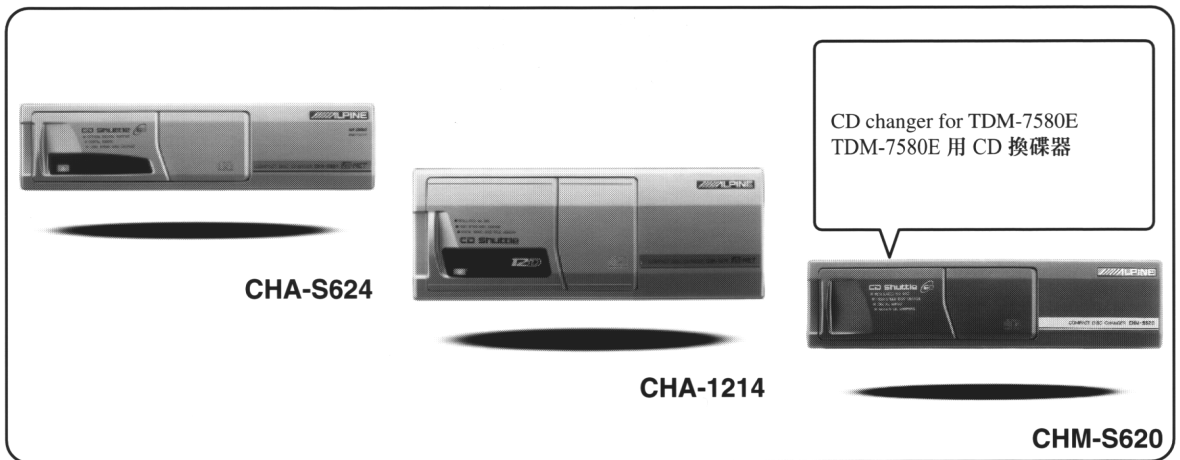

## Alpine CD Changers Give You More!

***More musical selections, more versatility, more convenience.***

An Alpine CD Changer adds more musical choices to your sound system. All models can be controlled from Alpine head units and deliver excellent sound quality. The CHA-S624 is a high-performance 6-disc changer with a new M DAC, Ai-NET compatibility, Optical Digital Output, 150 Disc Title Memory and CD TEXT. The CHA-1214 Ai-NET model holds 12 discs, and the CHM-S620 M-Bus model is a super-compact 6-disc changer.

## Alpine CD 換碟器讓您更加滿意！

更多音樂選項，更多功能性，更佳方便性。

Alpine CD 換碟器增添了更多樂聲系統選項。所有的型號都能從 Alpine 主機加以控制而產生極佳音質的音響。CHA-S624 是一個高性能，具新型 M DAC，Ai-NET 兼容的 6 碟式換碟器。可作光頻數字輸出、150 唱碟標題存儲和 CD TEXT。CHA-S1214 Ai-NET 型號保持 12 張唱碟，而 CHM-S620 M-Bus 型號是一個超小型的 6 碟式換碟器。

# Contents

## Operating Instructions

### WARNING

WARNING .....	2
CAUTION .....	2
PRECAUTIONS .....	2

### Basic Operation

Detaching the Front Panel .....	4
Attaching the Front Panel .....	4
Initial System Start-Up .....	4
Automatic Setup (A.S.U.) .....	4
Turning Power On and Off .....	5
Turning Loudness On/Off .....	5
Adjusting Volume/Bass/Treble/Balance (Between Left and Right)/Fader (Between Front and Rear) .....	5
Displaying Time .....	5
Setting Time .....	5

## Radio Operation

Manual Tuning .....	6
Automatic Seek Tuning .....	6
Manual Storing of Station Presets .....	6
Automatic Memory of Station Presets .....	7
Storing into Direct Access Preset (D.A.P.) Band .....	7
Tuning to Preset Stations .....	7

## Cassette Player Operation

Inserting/Ejecting Cassette .....	8
Normal Play .....	8
Repeat Play .....	8
Fast Forward and Rewind .....	9
Blank Skip (B.SKIP) .....	9
Manual Reverse .....	9
Programme Sensor (P.S.) .....	9

## CD Changer Operation

Controlling CD Changer (Optional) .....	10
Switching between Track No. and Elapsed Time Displays .....	10
Music Sensor (M.S.) Skip .....	10
Fast Forward and Backward .....	10
Repeat Play on Single Track or Entire Disc ....	10
M.I.X. (Random) Play .....	11

## Information

In Case of Difficulty .....	12
Specifications .....	13

## Installation and Connections

Warning .....	14
Caution .....	14
Precautions .....	14
Installation .....	15
Connections .....	16

# **WARNING**

## **WARNING**

The exclamation point within an equilateral triangle and "WARNING" are intended to alert the user to the presence of important operating instructions.

Failure to heed the instructions will result in severe injury or death.

### **DO NOT DISASSEMBLE OR ALTER.**

Doing so may result in an accident, fire or electric shock.

### **KEEP SMALL OBJECTS SUCH AS BATTERY OUT OF THE REACH OF CHILDREN.**

Swallowing them may result in serious injury. If swallowed, consult a physician immediately.

### **USE THE CORRECT AMPERE RATING WHEN REPLACING FUSES.**

Failure to do so may result in fire or electric shock.

### **DO NOT OPERATE ANY FUNCTION THAT TAKES YOUR ATTENTION AWAY FROM SAFELY DRIVING YOUR VEHICLE.**

Any function that requires your prolonged attention should only be performed after coming to a complete stop. Always stop the vehicle in a safe location before performing these functions. Failure to do so may result in an accident.

### **KEEP THE VOLUME AT A LEVEL WHERE YOU CAN STILL HEAR OUTSIDE NOISE WHILE DRIVING.**

Failure to do so may result in an accident.

### **USE THIS PRODUCT FOR MOBILE 12V APPLICATIONS.**

Use for other than its designed application may result in fire, electric shock or other injury.

### **DO NOT PLACE HANDS, FINGERS OR FOREIGN OBJECTS IN INSERTION SLOTS OR GAPS.**

Doing so may result in personal injury or damage to the product.

### **DO NOT BLOCK VENTS OR RADIATOR PANELS.**

Doing so may cause heat to build up inside and may result in fire.

## **CAUTION**

The exclamation point within an equilateral triangle and "CAUTION" are intended to alert the user to the presence of important operating instructions.

Failure to heed the instructions can result in injury or material damage.

### **HALT USE IMMEDIATELY IF A PROBLEM APPEARS.**

Failure to do so may cause personal injury or damage to the product. Return it to your authorized Alpine dealer or the nearest Alpine Service Centre for repairing.

## **PRECAUTIONS**

### **Temperature**

Be sure the temperature inside the vehicle is between +60°C (+140°F) and -10°C (+14°F) before turning your unit on.

### **Tape Slack**

Check and make sure any slack in the tape is taken up before inserting the tape into the unit. A loose tape can get caught in the mechanism and cause damage to the unit and the tape itself. Tighten the tape by inserting a pencil into the spindle hole and turn until all the slack has been taken up.



### **Excessively Thin Tape**

C-120 type cassette tapes are not recommended for use in automobile tape players.

### **Precision Tape Mechanism**

Prevent any foreign objects from entering the cassette opening as the precision mechanism and tape head may be damaged.

Never play dirty or dusty tapes – they can damage the tape head.

---

### **Tape Head Cleaning**

Periodic cleaning (approximately every 20 hours of use) of the tape head with a wet type head-cleaning cassette tape (available at audio stores) is necessary for best performance.

---

### **Fuse Replacement**

When replacing the fuse(s), the replacement must be of the same amperage as shown on the fuse holder. If the fuse blows more than once, carefully check all electrical connections for shorted circuitry. Also have your vehicle's voltage regulator checked.

---

### **Maintenance**

If you have problems, do not attempt to repair the unit yourself. Return it to your Alpine dealer or the nearest Alpine Service Station for servicing.

---

### **Installation Location**

Make sure the TDM-7580E will not be installed in a location subjected to:

- Direct sun and heat
- High humidity and water
- Excessive dust
- Excessive vibrations

---

### **Handling the Detachable Front Panel**

- Do not expose to rain or water.
- Do not drop or apply shock.

# Basic Operation

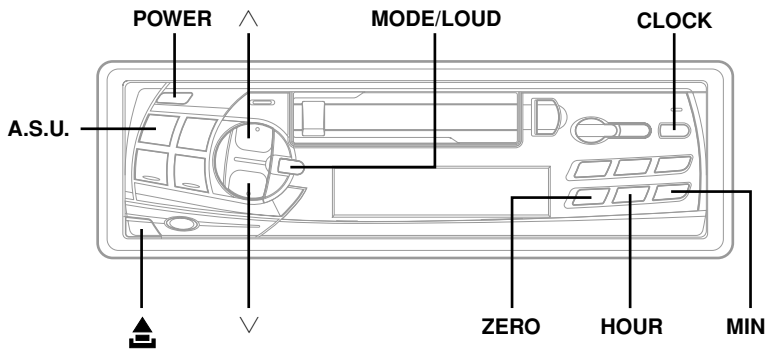

## Detaching the Front Panel

- 1 Press the **POWER** button to turn off the power.
- 2 Press the  (Release) button until the front panel pops out.
- 3 Grasp the left side of the front panel and pull it out.



### NOTES

- The front panel may become hot (especially the connector terminals). This is not a malfunction.
- To protect the front panel, place it in the supplied carrying case.

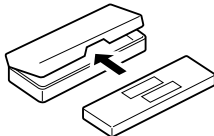

## Attaching the Front Panel

- 1 First, insert the right side of the front panel into the main unit. Align the 2 small holes on the front panel with the 2 projections on the main unit.
- 2 Push the left side of the front panel until it locks firmly into the main unit.

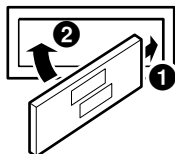

### NOTE

Before attaching the front panel, make sure that there is no dirt or dust on the connector terminals and no foreign object between the front panel and the main unit.

## Initial System Start-Up

- 1 Immediately after installing or applying power to the unit, it should be initialized. To do this, first, remove the detachable front panel. Behind the front panel, to the right of the connector, there is a small hole. Using a pencil or other pointed object, press the red Reset switch mounted behind this hole to complete the initialization procedure.

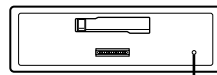

Reset switch



## Automatic Setup (A.S.U.)

This convenient feature sets up the unit automatically after installation.

- 1 Press the **POWER** button to turn on the unit.

### NOTE

When Power is turned on for the very first time, the A.S.U. (Automatic Set-Up) function will be initiated automatically. See A.S.U. description below.

- 2** Press and hold the **A.S.U.** (Automatic Setup) button for at least 3 seconds to activate the A.S.U. mode. "ASU" blinks in the display. The unit automatically performs the following operations.
1. Activates the Auto Memory mode.
  2. Gradually sets the Bass, Treble, Balance and Fader controls to their center positions.
  3. Gradually increases the volume to the position 12 in the display.
  4. Turns the Loudness on.
  5. Ends the A.S.U. mode.

## Turning Power On and Off

- 1** Press the **POWER** button to turn on the unit.
- NOTE**  
The unit can be turned on by pressing any other button except the eject  button.

The volume level gradually increases to the previous level you were listening to before the unit was turned off. Press the **POWER** button again to turn off the unit.

## Turning Loudness On/Off



Loudness introduces a special low- and high-frequency emphasis at low listening levels to compensate for the ear's decreased sensitivity to bass and treble sound.

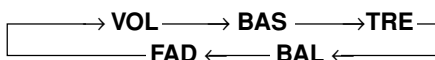

- 1** Press and hold the **LOUD** button for at least 2 seconds to activate or deactivate the loudness mode. The display shows "LOUD" when the loudness mode is activated.

## Adjusting Volume/Bass/Treble/Balance (Between Left and Right)/Fader (Between Front and Rear)

- 1** Press the **MODE** button repeatedly to choose the desired mode. Each press changes the modes as follows:



**NOTE**  
If the  or  button is not pressed within 5 seconds after selecting BASS, TREBLE, BALANCE, or FADER mode, the unit automatically returns to VOLUME mode.

- 2** Press the  or  button until the desired sound is obtained in each mode.

**NOTE**  
The BASS and TREBLE settings for each source (FM, AM, TAPE, and CD) are automatically memorized. These settings remain until you manually change them.

## Displaying Time

- 1** Press the **CLOCK** button to display the time. The unit displays the clock time.

**NOTE**  
Selecting any of the tuner, tape and CD functions while in the clock mode will interrupt the time display momentarily. The function selected will be displayed for about 5 seconds before the time returns to the display.

- 2** Press the **CLOCK** button to turn off the time and to show other functions.

## Setting Time

- 1** Press and hold the **CLOCK** button for at least 2 seconds while the display is showing the time. The time indication will begin to blink (for 5 seconds).
- 2** Press the **ZERO** button while the time indication is blinking to set seconds to "0."
- 3** Press the **HOUR** button to adjust the hours while the time indication is blinking.
- 4** Press the **MIN** button to adjust the minutes while the time indication is blinking. The time indication will stop blinking 5 seconds after the last adjustment. The time will automatically be set.

# Radio Operation

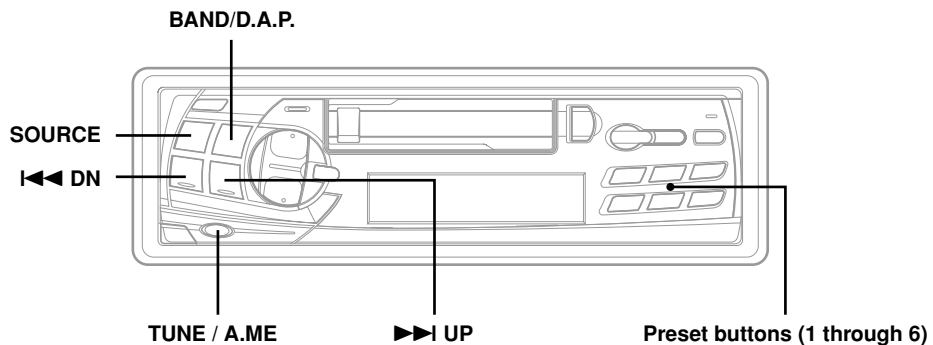

## Manual Tuning

- 1 Press the **SOURCE** button until radio frequency appears in the display.
- 2 Press the **BAND** button repeatedly until the desired radio band is displayed. Each press changes the radio bands as follows:

→ F1 → F2 → AM →

- 3 Press the **TUNE** button repeatedly until "DX SEEK" and "SEEK" disappears from the display.

### NOTE

The initial mode is DX SEEK.

- 4 Press the **I◀◀ DN** or **▶▶ UP** button to move downward or upward one step respectively until the desired station frequency is displayed.

### NOTE

"ST" indicator appears when a stereo FM station is tuned in.

## Automatic Seek Tuning

- 1 Press the **SOURCE** button until radio frequency appears in the display.
- 2 Press the **BAND** button repeatedly until the desired radio band is displayed. Each press changes the radio bands as follows:

→ F1 → F2 → AM →

- 3 Press the **TUNE** button to illuminate the DX and SEEK indicators in the display. With the DX mode activated, both strong and weak stations will be tuned in the Auto-Seek operation. Press again to return to the local mode. The DX indicator will turn off and the SEEK indicator will remain illuminated. Now, only strong stations will be tuned.

- 4 Press the **I◀◀ DN** or **▶▶ UP** button to automatically seek for a station downward or upward respectively. The unit will stop on the next station it finds. Press the same button again to seek the next station.

## Manual Storing of Station Presets

- 1 Select the radio band and tune in a desired radio station you wish to store in the preset memory.
- 2 Press and hold any one of the **Preset buttons (1 through 6)** for at least 2 seconds. The frequency display will begin to blink.
- 3 Press the **preset** button into which you wish to store the station while the frequency display is blinking (within 5 seconds). The display stops blinking once the station has been memorized. The display shows the band, preset No. with a triangle (△) and station frequency memorized.
- 4 Repeat the procedure to store up to 5 other stations onto the same band. To use this procedure for other bands, simply select the band desired and repeat the procedure.

A total of 24 stations can be stored in the preset memory (6 stations for each band; FM1, FM2, AM and D.A.P.).

### NOTE

If you store a station in a preset memory which already has a station, the current station will be cleared and replaced with the new station.



## Automatic Memory of Station Presets

---

- 1 Press the **SOURCE** button until the radio frequency appears in the display.
- 2 Press the **BAND** button repeatedly until the desired radio band is displayed.  
Each press changes the radio bands as follows:

→ **F1** → **F2** → **AM** →

- 3 Press and hold the **A. ME** button for at least 2 seconds.  
The frequency on the display continues to change while the automatic memory is in progress.  
The tuner will automatically seek and store 6 strong stations in the selected band in order of signal strength.  
When the automatic memory has been completed, the tuner goes to the station stored in the preset location No. 1.

### **NOTE**

*If no stations are stored, the tuner will return to the original station you were listening to before the auto memory procedure began.*

## Storing into Direct Access Preset (D.A.P.) Band

---

A combination of radio stations in any band (up to 6 stations) can be manually preset into the D.A.P. band.

- 1 Press and hold the **D.A.P.** button for at least 2 seconds until the D.A.P. indicator appears.  
Press the **BAND** button to select FM or AM.  
The selected band will be displayed.  
To memorize stations onto the D.A.P. band, follow the steps for the automatic or Manual Storing of Station Presets section above.

### **NOTE**

*When using the Automatic Memory function with D.A.P., the first 3 presets will be filled with FM stations and the last 3 are filled with AM stations.*

To cancel the D.A.P. mode, press and hold the D.A.P. button for at least 2 seconds. The D.A.P. indicator will turn off.

## Tuning to Preset Stations

---

- 1 Press the **SOURCE** button until the radio frequency appears in the display.
- 2 Press the **BAND** button repeatedly until the desired band is displayed.  
Each press changes the radio bands as follows:

→ **F1** → **F2** → **AM** →

To select the D.A.P. band, press and hold the D.A.P. button for at least 2 seconds until the D.A.P. indicator appears in the display.

- 3 Press the station **preset** button that has your desired radio station in memory.  
The display shows the band, preset number with a triangle and frequency of the station selected.

# Cassette Player Operation

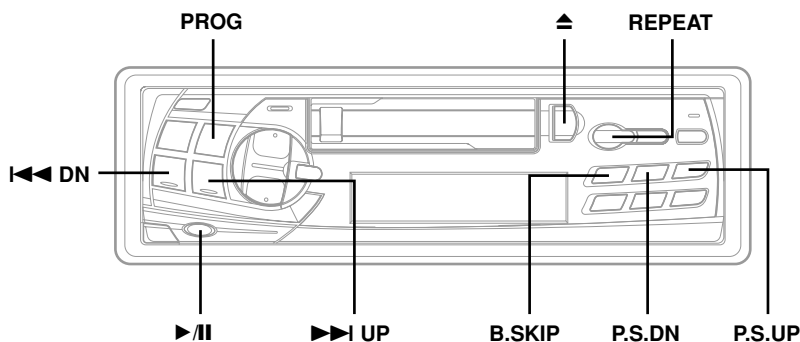

## Inserting/Ejecting Cassette

- 1 Insert a cassette tape into the slot with the open side facing right.

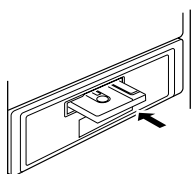

When the cassette is loaded, the player automatically starts tape playback and indicates "TAPE" in the display.

- 2 Press the **Eject** ( $\blacktriangle$ ) button when you want to eject the cassette tape.

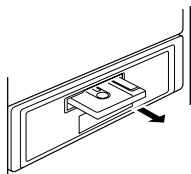

### NOTES

- When power is turned off or the front panel is removed, the full-logic mechanism will automatically switch to the PAUSE mode. This protects the tape from being deformed by the pinch-rollers if left for long periods.
- Auto Metal  
When a metal cassette tape is inserted, the player automatically adjusts the equalization for metal or any other high bias tape for optimum sound. The display shows "MTL."

## Normal Play

- 1 Insert a cassette tape into the slot with the open side facing to the right.  
The player automatically starts tape playback and the display shows "TAPE" and the tape side being played ( $\blacktriangle$  or  $\blacktriangledown$ ).

When the end of the tape is reached, the player automatically reverses the tape direction and plays the other side of the tape.

If a tape is already loaded in the cassette player, press the **SOURCE** button to select the TAPE mode.

- 2 Press the  $\blacktriangleright/\text{II}$  button to pause the tape playback.  
Both tape direction indicators appear during the pause mode.  
Press again to resume the tape playback.
- 3 Press the **Eject** ( $\blacktriangle$ ) button to stop the tape play and eject the cassette.  
The tape-direction indicator disappears.

## Repeat Play

- 1 Press the **REPEAT** button and the REPEAT indicator appears in the display.  
The current programme will be played back repeatedly.

Press the **REPEAT** button to stop the repeat play.  
The REPEAT indicator disappears.

## Fast Forward and Rewind

---

- 1 Press the **⏮ DN** or **⏭ UP** button during tape play to fast rewind or forward the tape respectively.  
The tape side indicator  $\triangleleft$  or  $\triangleright$  blinks indicating the direction of the tape. When the end of the tape is reached in the fast rewind mode, the player stops automatically and begins playing from the beginning of the same side.  
When the end of the tape is reached in the fast forward mode, the player stops automatically and begins playing from the beginning of the opposite side.
- 2 Press the **⏭ UP** button during forwarding to stop fast forwarding and resume tape play.  
Press the **⏮ DN** button during rewinding to stop rewinding and resume tape play.  
The tape side indicator stops blinking.

## Blank Skip (B.SKIP)

---

- 1 Press the **B.SKIP** button during tape play to skip over blank portions of the tape lasting 15 seconds or longer, "B.SKIP" appears on the display.  
Press the **B.SKIP** button to cancel the blank skip mode.  
"B.SKIP" disappears from the display.

## Manual Reverse

---

- 1 Press the **PROG** button during tape play to change the direction of play.  
The tape side indicators ( $\triangleleft$  and  $\triangleright$ ) change to show which side of the cassette is being played.

## Programme Sensor (P.S.)

---

- 1 Press the **P.S. DN** button once during tape play to return to the beginning of the current selection being played.  
If you wish to return to the beginning of a selection further back, press repeatedly until the number of selections you would like to skip is shown in the display.  
The display will show PS-1 with the first press and will increase by one with each successive press up to PS-9. The tape indicator will blink showing the direction of your search.  
Press the **P.S. UP** button once during tape play to advance to the beginning of the next selection.  
If you wish to advance to the beginning of a selection further ahead, press repeatedly until the number of selections you would like to skip is shown in the display.  
The display will show PS+1 with the first press and will increase by one with each successive press up to PS+9. The tape indicator will blink showing the direction of your search during searching operation.

### NOTES

- The programme sensor feature is functional in the tape play mode only.
- You can advance to the 9th (max.) programme or return to the 8th (max.) programme.

# CD Changer Operation

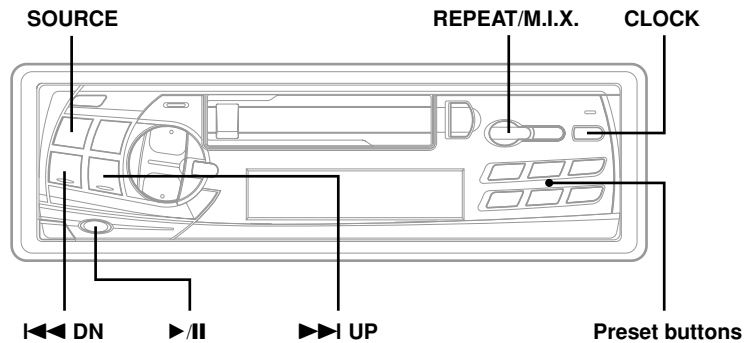

## Controlling CD Changer (Optional)

The CD controls on the TDM-7580E will function only when a CD Changer (M-Bus) is connected.

- 1 Press the **SOURCE** button to activate the CD Changer.  
The display shows the disc number and track number.  
**NOTE**  
*To start play or pause playback, press the ►|| button.*
- 2 When a 6-disc CD Changer is connected:  
Press the **Preset buttons** to select the desired disc loaded in the CD Changer.

## Switching between Track No. and Elapsed Time Displays

- 1 Each press of the **CLOCK** button during CD playback causes change of the display between the track number and clock time.
- 2 Press and hold the **CLOCK** button for at least 2 seconds while the track number is displayed.  
The display changes to show the elapsed time for the track being played.

## Music Sensor (M.S.) Skip

- 1 Momentarily press the ◀◀ **DN** button once to return to the beginning of the current track.  
If you wish to return to the beginning of a track further back, repeatedly press until you reach the desired track.  
  
Press the ▶▶ **UP** button once to advance to the beginning of the next track.  
If you wish to advance to the beginning of a track further ahead, press repeatedly until the desired track is reached.  
  
**NOTE**  
*The music sensor feature is functional in the play or pause mode.*

## Fast Forward and Backward

- 1 Press and hold the ◀◀ **DN** or ▶▶ **UP** button to quickly move backward or forward respectively until you reach the desired portion.  
  
**NOTE**  
*This feature works only in the CD playback mode.*

## Repeat Play on Single Track or Entire Disc

- 1 Press the **REPEAT** button to display "REPEAT" or "REPEAT ALL" to play back repeatedly the current track being played or the entire disc selected.  
  
**NOTE**  
*Single track cannot be repeated during M.I.X. play.*

## **M.I.X. (Random) Play**

---

**1** Press and hold the **M.I.X.** button in CD play for at least 2 seconds to turn on the M.I.X. mode. When this mode is turned on, the tracks on the currently playing disc will be played back in a random sequence.

To cancel the M.I.X. mode, press and hold the **M.I.X.** button for at least 2 seconds. The M.I.X. indicator disappears from the display.

# Information

## In Case of Difficulty

---

If you encounter a problem, please review the items in the following checklist. This guide will help you isolate the problem if the unit is at fault. Otherwise, make sure the rest of your system is properly connected or consult your authorized Alpine dealer.

### Basic

---

#### No function or display.

- Vehicle's ignition is off.
  - If connected following instructions, the unit will not operate with the vehicle's ignition off.
- Improper power lead connections.
  - Check power lead connections.
- Blown fuse.
  - Check the fuse on the battery lead of the unit; replace with the proper value if necessary.

### Radio

---

#### Unable to receive stations.

- No antenna or open connection in cable.
  - Make sure the antenna is properly connected; replace the antenna or cable if necessary.

#### Unable to tune stations in the seek mode.

- You are in a weak signal area.
  - Make sure the tuner is in the DX mode.
- If the area you are in is a primary signal area, the antenna may not be grounded and connected properly.
  - Check your antenna connections; make sure the antenna is properly grounded at its mounting location.
- The antenna may not be the proper length.
  - Make sure the antenna is fully extended; if broken, replace the antenna with a new one.

#### Broadcast is noisy.

- The antenna is not the proper length.
  - Extend the antenna fully; replace it if it is broken.
- The antenna is poorly grounded.
  - Make sure the antenna is grounded properly at its mounting location.

### Cassette

---

#### Tape playback sounds dull.

- The tape head needs cleaning.
  - Clean the tape head.

### CD

---

#### CD Changer not functioning.

- Out of operating temperature range +50°C (+120°F) for CD.
  - Allow the vehicle's interior (or trunk) temperature to cool.

#### CD playback sound is wavering.

- Moisture condensation in the CD Module.
  - Allow enough time for the condensation to evaporate (about 1 hour).

#### Unable to fast forward or backward the CD.

- The CD has been damaged.
  - Eject the CD and discard it; using a damaged CD in your unit can cause damage to the mechanism.

#### CD playback sound skips due to vibration.

- Improper mounting of the CD Changer.
  - Securely re-mount the CD Changer.

- Disc is very dirty.
  - Clean the disc.

- Disc has scratches.
  - Change the disc.

#### CD playback sound skips without vibration.

- Dirty or scratched disc.
  - Clean the disc; damaged disc should be replaced.

#### Single (8 cm) disc does not play.

- Single CD adaptor is not used.
  - Attach a single CD adaptor (recommended by Alpine) to the single disc and insert into the CD magazine.

## Indication for CD Changer

---H

- Protective circuit is activated due to high temperature.
  - The indicator will disappear when the temperature returns to within operation range.

E - 01

- Malfunction in the CD Changer.
  - Consult your Alpine dealer. Press the magazine eject button and pull out the magazine. Check the indication. Insert the magazine again. If the magazine cannot be pulled out, consult your Alpine dealer.
- Magazine ejection not possible.
  - Press the magazine eject button. If the magazine does not eject, consult your Alpine dealer.

----

- No magazine is loaded into the CD Changer.
  - Insert a magazine.

T---

- No indicated disc.
  - Choose another disc.

EEEE

- Misconnection or disconnection of CD Changer.
  - Check connection between CD Changer and control unit.

## Specifications

### FM TUNER SECTION

Tuning Range	87.5 – 108.0 MHz
Mono Usable Sensitivity	9.3 dBf (0.8 $\mu$ V/75 ohms)
50 dB Quieting Sensitivity	13.5 dBf (1.3 $\mu$ V/75 ohms)
Alternate Channel Selectivity	80 dB
Signal-to-Noise Ratio	65 dB
Stereo Separation	35 dB
Capture Ratio	2.0 dB

### AM TUNER SECTION

Tuning Range	531 – 1,602 kHz
Usable Sensitivity	22.0 $\mu$ V

### TAPE PLAYER SECTION

Tape Speed	1-7/8 ips (4.8 cm/sec) $\pm$ 0.7%
Wow & Flutter	0.06%
Tape Signal-to-Noise Ratio	60 dB
Frequency Response	
With Alpine Test Tape	30–20,000 Hz ( $\pm$ 3 dB)

### GENERAL

Power Requirement	14.4 V DC (11–16 V allowable)
Maximum Pre-Output Voltage	2 V/10k ohms
Maximum Power Output*	35 W $\times$ 4
Continuous Power Output**	15 W $\times$ 4
Output Voltage	500 mV/10 k ohms
Bass	$\pm$ 15 dB at 30 Hz
Treble	$\pm$ 10 dB at 10 kHz
Weight	1.4 kg (3 lbs. 1 oz)

### CHASSIS SIZE

Width	178 mm (7")
Height	50 mm (2")
Depth	155 mm (6-1/8")

### NOSEPIECE SIZE

Width	170 mm (6-3/4")
Height	46 mm (1-13/16")
Depth	19 mm (3/4")

Due to continuous product improvement, specifications and design are subject to change without notice.

\* Under maximum operating voltage and input signal, into 4 ohms.

\*\* 0.8% THD, at 14.4 V battery voltage.

# Installation and Connections

Before installing or connecting the unit, please read the following and pages 2 and 3 of this manual thoroughly for proper use.

## Warning

### **USE ONLY IN CARS WITH A 12 VOLT NEGATIVE GROUND.**

(Check with your dealer if you are not sure.) Failure to do so may result in fire, etc.

### **BEFORE WIRING, DISCONNECT THE CABLE FROM THE NEGATIVE BATTERY TERMINAL.**

Failure to do so may result in electric shock or injury due to electrical shorts.

### **DO NOT SPLICE INTO ELECTRICAL CABLES.**

Never cut away cable insulation to supply power to other equipment. Doing so will exceed the current carrying capacity of the wire and result in fire or electric shock.

### **DO NOT INSTALL IN LOCATIONS WHICH MIGHT HINDER VEHICLE OPERATION, SUCH AS THE STEERING WHEEL OR SHIFT LEVER.**

Doing so may obstruct forward vision or hamper movement etc. and results in serious accident.

### **DO NOT DAMAGE PIPE OR WIRING WHEN DRILLING HOLES.**

When drilling holes in the chassis for installation, take precautions so as not to contact, damage or obstruct pipes, fuel lines, tanks or electrical wiring. Failure to take such precautions may result in fire.

### **DO NOT USE BOLTS OR NUTS IN THE BRAKE OR STEERING SYSTEMS TO MAKE GROUND CONNECTIONS.**

Bolts or nuts used for the brake or steering systems (or any other safety-related system), or tanks should NEVER be used for installations or ground connections. Using such parts could disable control of the vehicle and cause fire etc.

### **MAKE THE CORRECT CONNECTIONS.**

Failure to make the proper connections may result in fire or product damage.

## Caution

### **ARRANGE THE WIRING SO IT IS NOT CRIMPED OR PINCHED BY A SHARP METAL EDGE.**

Route the cables and wiring away from moving parts (like the seat rails) or sharp or pointed edges. This will prevent crimping and damage to the wiring. If wiring passes through a hole in metal, use a rubber grommet to prevent the wire's insulation from being cut by the metal edge of the hole.

## **HAVE THE WIRING AND INSTALLATION DONE BY EXPERTS.**

The wiring and installation of this unit requires special technical skill and experience. To ensure safety, always contact the dealer where you purchased this product to have the work done.

## **USE SPECIFIED ACCESSORY PARTS AND INSTALL THEM SECURELY.**

Be sure to use only the specified accessory parts. Use of other than designated parts may damage this unit internally or may not securely install the unit in place. This may cause parts to become loose resulting in hazards or product failure.

## **DO NOT INSTALL IN LOCATIONS WITH HIGH MOISTURE OR DUST.**

Avoid installing the unit in locations with high incidence of moisture or dust. Moisture or dust that penetrates into this unit may result in product failure.

## Precautions

- Be sure to disconnect the cable from the (-) battery post before installing your TDM-7580E. This will reduce any chance of damage to the unit in case of a short-circuit.
- Be sure to connect the color coded leads according to the diagram. Incorrect connections may cause the unit to malfunction or damage to the vehicle's electrical system.
- When making connections to the vehicle's electrical system, be aware of the factory installed components (e.g. on-board computer). Do not tap into these leads to provide power for this unit. When connecting the TDM-7580E to the fuse box, make sure the fuse for the intended circuit of the TDM-7580E has the appropriate amperage. Failure to do so may result in damage to the unit and/or the vehicle. When in doubt, consult your ALPINE dealer.
- The TDM-7580E uses female RCA-type jacks for connection to other units (e.g. amplifier) having RCA connectors. You may need an adaptor to connect other units. If so, please contact your authorized ALPINE dealer for assistance.
- Be sure to connect the speaker (-) leads to the speaker (-) terminal. Never connect left and right channel speaker cables to each other or to the vehicle body.

## IMPORTANT

Please record the serial number of your unit in the space provided below and keep it as a permanent record. The serial number plate is located on the bottom of the unit.

SERIAL NUMBER: \_\_\_\_\_  
INSTALLATION DATE: \_\_\_\_\_  
INSTALLATION TECHNICIAN: \_\_\_\_\_  
PLACE OF PURCHASE: \_\_\_\_\_



# Installation

3

1

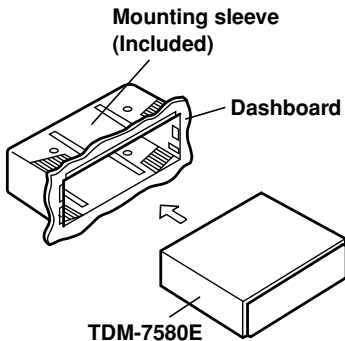

Remove the Detachable Front Panel (refer to page 4). Slide mounting sleeve from main unit. Slide the mounting sleeve into the dashboard.

2

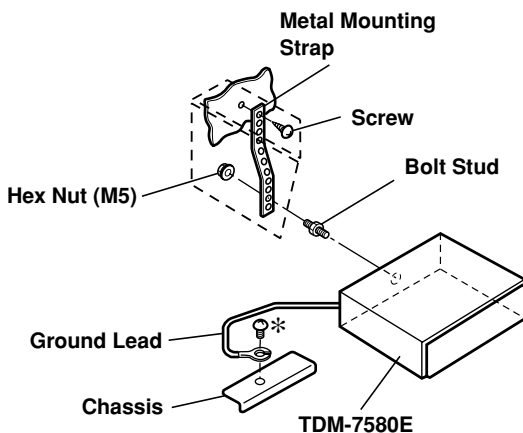

Reinforce the head unit with the metal mounting strap (not supplied). Secure the ground lead of the unit to a clean metal spot using a screw (\*) already attached to the vehicle's chassis. Connect each input lead coming from an amplifier or equalizer to the corresponding output lead coming from the left rear of the TDM-7580E. Connect all other leads of the TDM-7580E according to details described in the CONNECTIONS section.

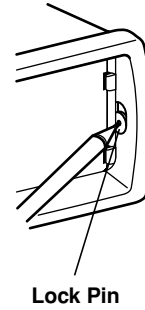

Slide the TDM-7580E into the dashboard. When the unit is in place, make sure the locking pins are fully seated in the down position. This can be done by pressing firmly in on the unit while pushing the locking pin down with a small screwdriver. This ensures that the unit is properly locked and will not accidentally come out from the dashboard. Install the Detachable Front Panel.

## Removal

1. Remove the Detachable Front Panel.
2. Use a small screwdriver (or similar tool) to push the locking pins to the "up" position (see above drawing). As each pin is unlocked, gently pull out on the unit to make sure it does not re-lock before unlocking the second pin.
3. Pull the unit out, keeping it unlocked as you do so.

## <JAPANESE CAR>

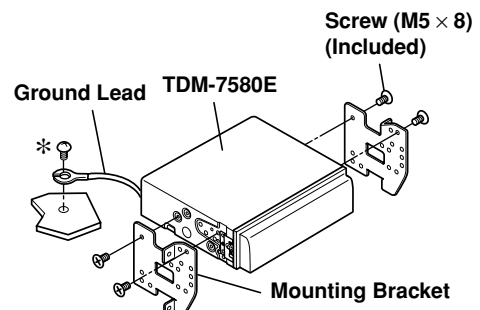
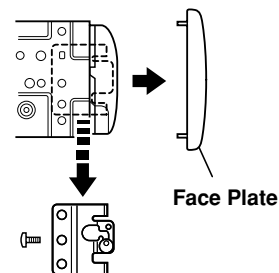

# Installation and Connections

## Connections

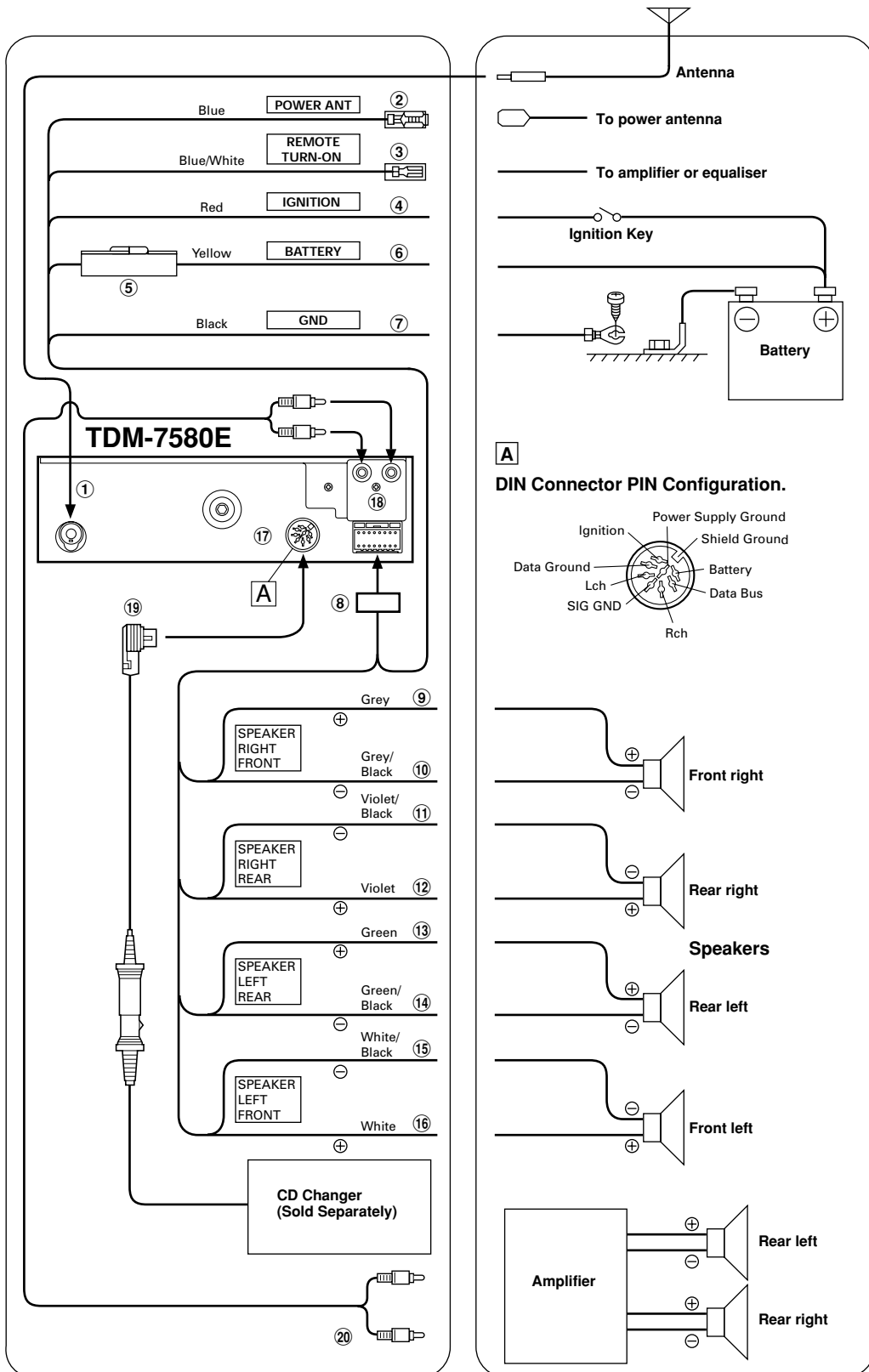

① **Antenna Receptacle**

② **Power Antenna Lead (Blue)**

Connect this lead to the +B terminal of your power antenna, if applicable.

**NOTE**

*This lead should be used only for controlling the vehicle's power antenna. Do not use this lead to turn on an amplifier or a signal processor, etc.*

③ **Remote Turn-On Lead (Blue/White)**

Connect this lead to the remote turn-on lead of your amplifier or signal processor.

④ **Switched Power Lead (Ignition) (Red)**

Connect this lead to an open terminal on the vehicle's fuse box or another unused power source which provides (+) 12V only when the ignition is turned on or in the accessory position.

⑤ **Fuse Holder (15A)**

⑥ **Battery Lead (Yellow)**

Connect this lead to the positive (+) post of the vehicle's battery.

⑦ **Ground Lead (Black)**

Connect this lead to a good chassis ground on the vehicle. Make sure the connection is made to bare metal and is securely fastened using the sheet metal screw provided.

⑧ **Power Supply Connector**

⑨ **Right Front (+) Speaker Output Lead (Grey)**

⑩ **Right Front (-) Speaker Output Lead (Grey/Black)**

⑪ **Right Rear (-) Speaker Output Lead (Violet/Black)**

⑫ **Right Rear (+) Speaker Output Lead (Violet)**

⑬ **Left Rear (+) Speaker Output Lead (Green)**

⑭ **Left Rear (-) Speaker Output Lead (Green/Black)**

⑮ **Left Front (-) Speaker Output Lead (White/Black)**

⑯ **Left Front (+) Speaker Output Lead (White)**

⑰ **DIN Connector**

Connect this to the DIN connector on the CD Changer.

⑱ **Rear Output RCA Connectors**

RED is right and WHITE is left.

⑲ **DIN Extension Cable**

**NOTE**

*For some installations, an L-type DIN connector would simplify installation. Use the Alpine 491002 Adapter (Sold Separately) if your changer did not include an L-type DIN.*

⑳ **RCA Extension Cable (Sold Separately)**

## Free Manuals Download Website

<http://myh66.com>

<http://usermanuals.us>

<http://www.somanuals.com>

<http://www.4manuals.cc>

<http://www.manual-lib.com>

<http://www.404manual.com>

<http://www.luxmanual.com>

<http://aubethermostatmanual.com>

Golf course search by state

<http://golfingnear.com>

Email search by domain

<http://emailbydomain.com>

Auto manuals search

<http://auto.somanuals.com>

TV manuals search

<http://tv.somanuals.com>