

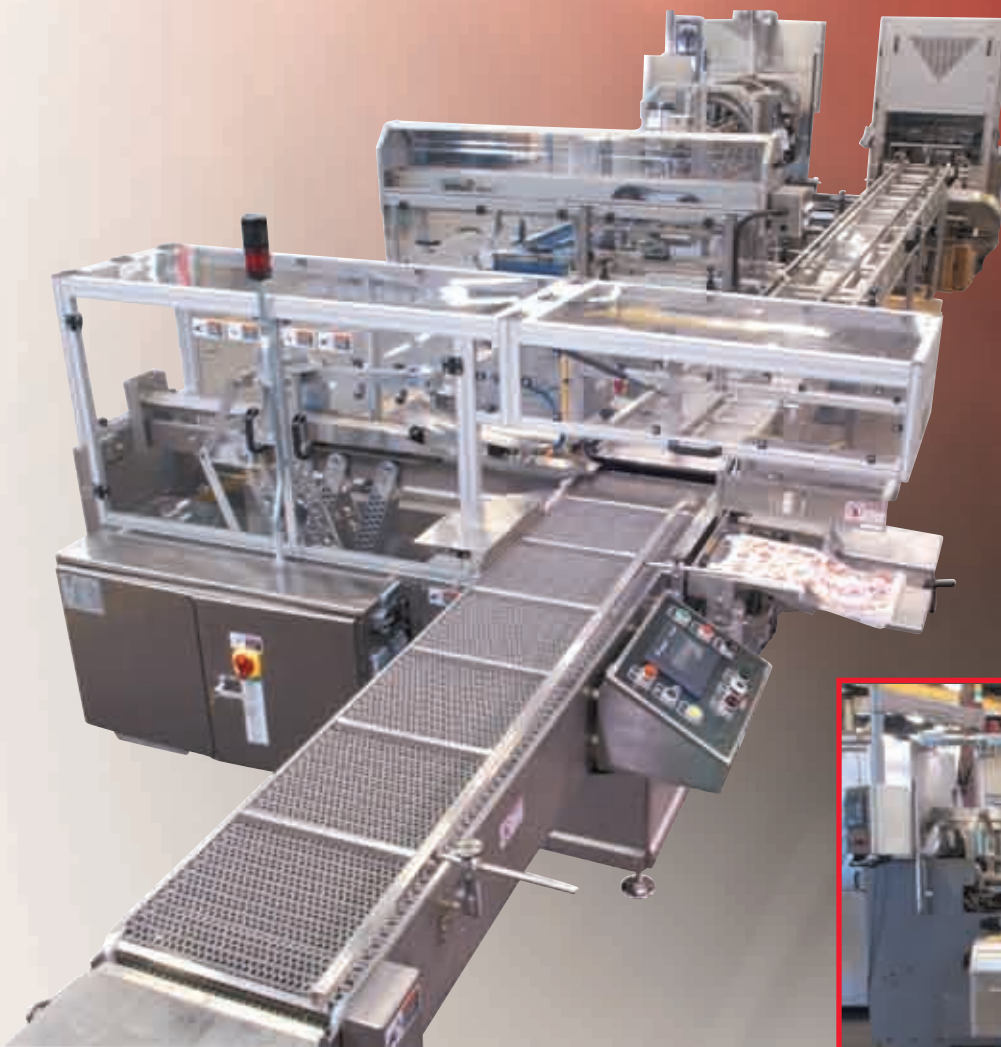

COMPLETE WRAPPING SYSTEM WITH BY-PASS OPTION AND LOAF SPLITTER-TURNER



- The SW-75 is designed for today's bread wrapping needs
- The SW-75 is designed to work in conjunction with the AMF Saber 75 Slicer and Mark 75 Bread Bagger to provide an efficient and comprehensive bread packaging system
- The SW-75 features a durable design focused on long term machine life including the only solid frame design available
- The SW-75 incorporates the latest automated electronics including servo drives, AC drives, electronic solenoids, PLC, and operator interface controls with recipe management and diagnostic capabilities

MODEL SW-75 BREAD WRAPPER

FEATURES & BENEFITS

Solid Frame

A solid frame was chosen over a stainless steel tubular weldment for long term durability. We back this with a 25-year warranty.

Simplicity

Only 4 of the original 9 cams remain. Most of the linkages and adjustment points related to these cams have been removed as well, resulting in greatly improved access for maintenance or changeovers. The Bottom Bed is now very similar to our Side Sealer System, as there are no driven parts

Automatic Set-up and Monitoring

Servos, AC drives, Electric Solenoids and Pneumatics now control most machine functions through a PLC. These features dramatically simplify set-up and greatly reduce operator input and adjustment. Critical set-up systems are automatically measured and will not allow the machine to run if they are out of specification. Machine set-up can be accomplished 2 ways; by selection of a product on the standard touch screen, or by selection of a "Size to Pusher" option (Patent Pending). Either way automatically measures the pusher plate, top end and cross-feed and sets the correct positions.

Remote Access

The control system is Ethernet / Modem ready for remote troubleshooting and monitoring. Most machine functions can be diagnosed remotely without the time delay of dispatching a technician. Costs associated with equipment service, and more importantly down time, can be greatly reduced with this feature.

Load Sharing and POD

Packaging on Demand (POD) is a feature to save machine wear. If product is not present, it will sequentially shut down or idle subsystems of the machine and "wake up" when product is again present. In multiple unit installations, product load to each machine can be sensed. If one machine is idled, the remaining units can increase speed to help absorb the load.

Film Feed

The standard paper feed system requires only the operator to load the film and set the width. The rest of the system is automatic and requires no operator adjustments. The film spool sits on a pair of rollers that are driven with an AC drive and controlled by a dancer sensor. This is less complicated and less expensive than a servo controlled unit that pulls the film through a series of rollers.

An automatic film splicer is available as an option. Production is never interrupted or slowed down during film changes and the splice is hardly noticeable.

Sealing

The patented Side Sealer System is undisputedly recognized as the best in the industry. So much so, that our customers have installed them on competitive machines. With no driven parts, flexibility of arrangement and very accurate temperature control, it continues to lead the industry.

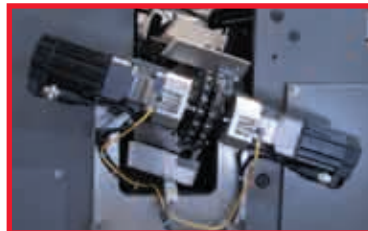

Servo Motor Drive



Cam Drive

PRODUCT SPECIFICATIONS

- Rated for 60 PPM continuous operation (65 in temporary situation)
- Loaf lengths: 5.75" to 14" standard (smaller and larger loaf set-up are available as an option)



MODEL SW-75 BREAD WRAPPER

MECHANICAL SPECIFICATIONS

- Four axis servo motion system
 - Main drive
 - Product Infeed (2)
 - Underlap
- Light curtain guarding
- Patented side sealer system
- Shortened overhead and BW-7 type paddles
- Roller bottom bed with integral bottom sealer kit mounted immediately after the extension plate (up front)
- Static bar eliminator system
- Suction manifold for film retention
- Powder coated steel frame
- Packaging on demand system
- Electro mechanical pusher
- Preset, automatic set-up and/or automatic set-up to pusher plate
- Electro mechanical film feed system
- Standard or opposite handed configuration



Side Sealer

ELECTRICAL SPECIFICATIONS

- Electronic, torque overload systems
- Allen Bradley, PLC temperature control system
- Ethernet or Modem connection
- Electronic cam motion linkage
- Allen Bradley and Kebco AC drives
- Allen Bradley MPL servo motors
- Allen Bradley PanelView 600 color touchscreen
- 24 Volt control wiring
- 230 or 460 Volts, 60 Cycle, 3 Phase



Operator Interface

MECHANICAL OPTIONS

- Automatic film splicer
- Wrapper by-pass conveyor system
- Product transfer conveyor
- Integral loaf turner
- Nickel plated frame option
- Smaller or larger loaf set-ups
- Flexible layouts



Automatic Film Splicer

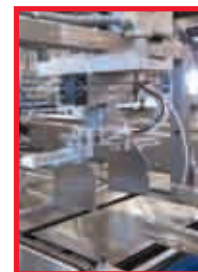

Integral Loaf Turner



MODEL SW-75 BREAD WRAPPER

DIMENSIONAL DRAWING

BY-PASS OPTION
W/LOAF SPLITTER AND TURNER

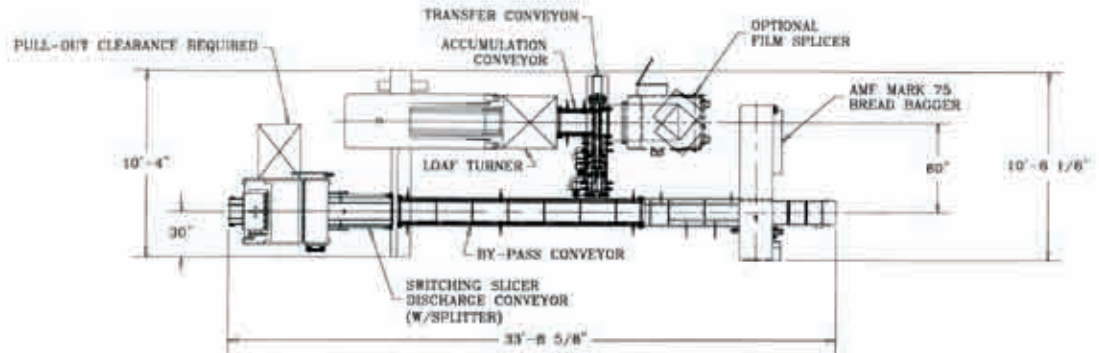

WITH BY-PASS OPTION

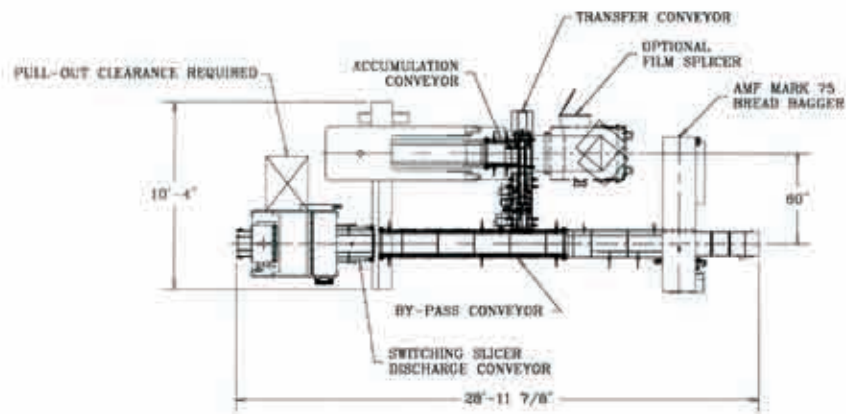

IN-LINE WRAPPING

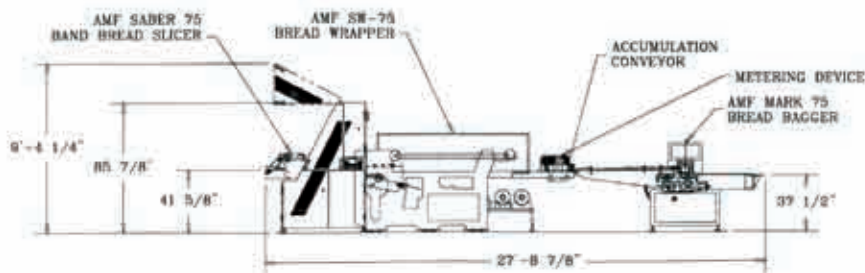
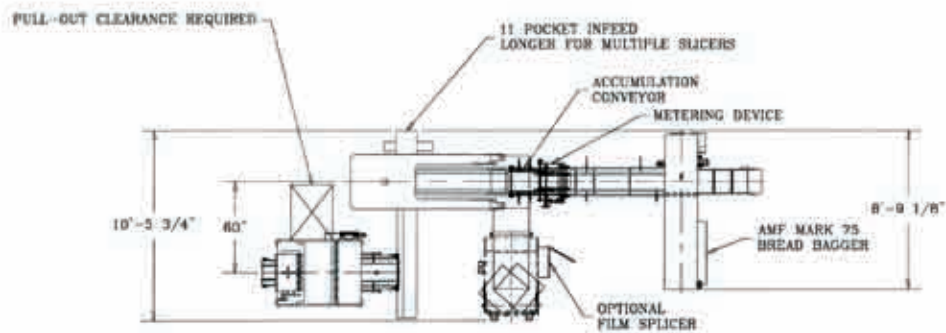

HEADQUARTERS
AMF Bakery Systems
2115 West Laburnum Avenue
Richmond, Virginia 23227
1-800-225-3771
or 804-355-7961
FAX : 1-804-342-9724

EUROPEAN OPERATION
West Park Ring Road
Leeds LS16 6QQ England
Tel. : 1132-787110
Fax : 1132-741415
sales@amfbakery.com

FOR MORE INFORMATION PLEASE CALL YOUR ACCOUNT MANAGER OR

1-800-BAKERS-1
www.amfbakery.com

Free Manuals Download Website

<http://myh66.com>

<http://usermanuals.us>

<http://www.somanuals.com>

<http://www.4manuals.cc>

<http://www.manual-lib.com>

<http://www.404manual.com>

<http://www.luxmanual.com>

<http://aubethermostatmanual.com>

Golf course search by state

<http://golfingnear.com>

Email search by domain

<http://emailbydomain.com>

Auto manuals search

<http://auto.somanuals.com>

TV manuals search

<http://tv.somanuals.com>