

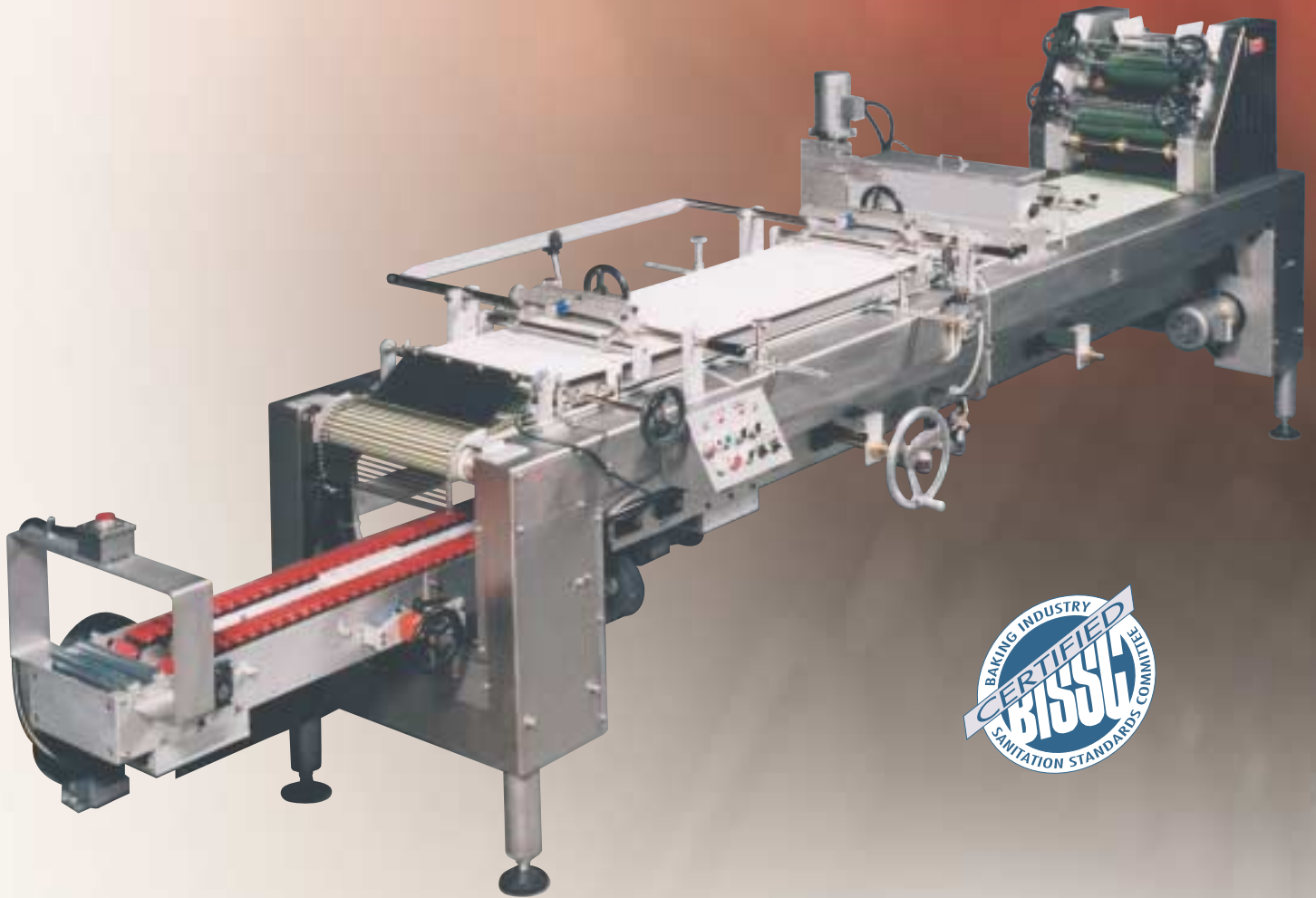

# STRAIGHT LINE SHEETER/MOULDER/PANNER



- For frozen dough and specialty breads
- 6 oz. to 36 oz. and 6" to 18" dough piece length
- All stainless steel construction
- Equipment meets OSHA requirements
- Working range: 6 oz. to 36 oz., 6 in. to 18 in. length

# STRAIGHT LINE SHEETER/MOULDER/PANNER

## SPECIAL DESIGN FEATURES

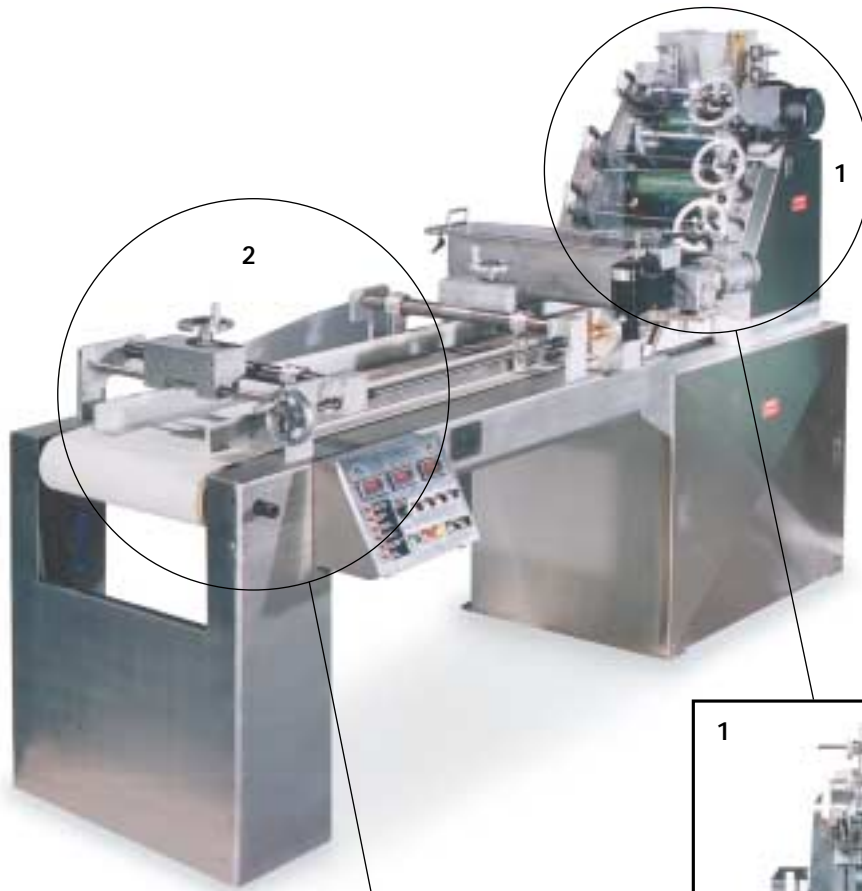

### "MOULDER OPTION"

Above shown with removable style pressure board adjustable on both ends.

### "HOPPER"

Construction Lexan® adjustable dough guide



Above shown with motorized dough guide adjustment with digital readout.

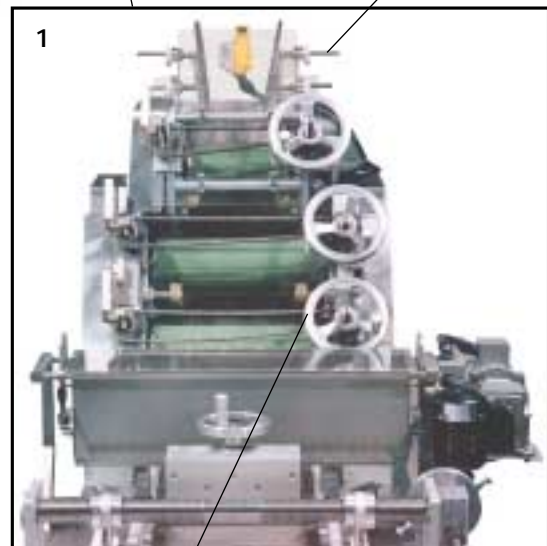

Shown with:

- 3 sets of sheeting rolls (10" wide)
- Driven by motor/reducer 3/4 H.P.



# STRAIGHT LINE SHEETER/MOULDER/PANNER

## SPECIAL DESIGN FEATURES

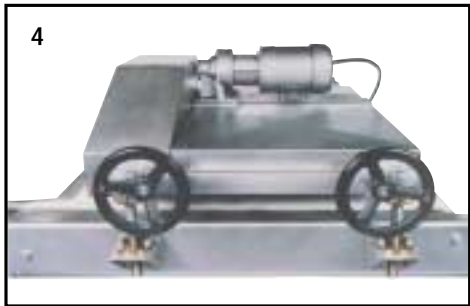

4  
Stretcher section. Full stainless steel construction. Easy access to all components, fully adjustable height permitting maximum desired product length. (Motor 1/2 H.P.)

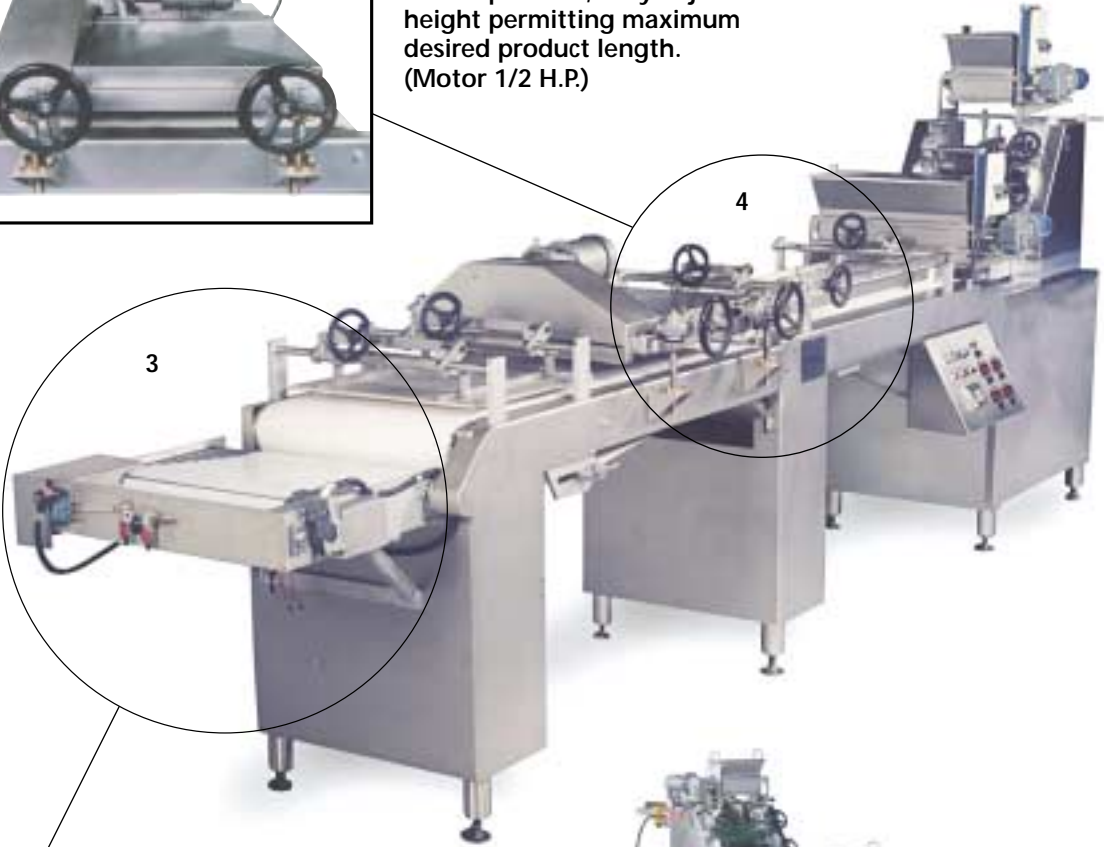

3  
Special diverter with aligner and pneumatically operated drop gate. Aluminum and stainless steel construction. This unit transports and facilitates smooth transfer of dough pieces onto desired position of freezer belt.



Above shown with:

- pressure board belt with a pneumatically operated lifting device for sanitation purposes (motorized or not motorized) or fix pressure board
- special extended length pressure board (80")



# STRAIGHT LINE SHEETER/MOULDER/PANNER

## MECHANICAL SPECIFICATIONS

- Special slanted infeed conveyor with Teflon® coated dough guides and adjustable flattener roller (elev.61"±1").
- D.C. variable speed, removable stainless steel rotary flour sifters with automatic cut-off.
- Sheeting rolls (17" wide) adjustable.
- Top sheeting roll is grooved to prevent dough hesitation.
- Sheeting rolls driven by a 2 H.P. motor.
  - Top: 320 RPM
  - Bottom: 400 RPM
- Sheeter belt (14" wide) SP93F Polytek endless.
  - Mechanical variable speed
  - Elevation 38" ± 1"
- Sheeting roll guard (Lexan®) with safety switches.
- Stainless steel removable panels with safety switches.
- Adjustable legs.
- Stainless steel sliding catch pan.
- Sheeter head with timing belt (optional).

## ELECTRICAL SPECIFICATIONS

- Nema remote control mounted under Moulder frame with the following:
  - Allen Bradley starters
  - D.C. controls for flour sifters (2)
  - Allen Bradley SLC 5/03 processor
  - Main disconnect switch
  - Relays, terminal block, wiring
- Nema 4 operator panel mounted to Moulder frame with the following:
  - Allen Bradley push-buttons and alarm message display
  - Potentiometers for flour sifters, sheeter belt
  - Safeties
  - Emergency stop
  - Red Lion display to indicate fault messages
- CAD electrical drawings
- A.C. inverter on the following:
  - Sheeter rolls
  - Sheeter belt
  - Flour sifters (2)

## MOULDER SECTION

- 24" wide F.D.A. approved synthetic moulding belt.
- Adjustable stainless steel curling mat.
- D.C. variable speed, removable stainless steel rotary flour sifter.
- Removable style pressure board (8" wide X 80" long) adjustable on both ends.
- U.H.M.W. side guides with stainless steel backing.
- Stainless steel catch pan.

## OPTIONS

### MOULDER

- Removable style pressure boards:  
Note: "Special" widths and lengths available upon request.
- Motorized dough guides adjustment with digital readout.
- Pneumatically operated pressure board lifting device.

- Stainless steel Dough Stretcher with 2nd pressure board.
- Product Diverter switch and aligner.

### SHEETER

- New dough spacer (larger).
- Third set of sheeting rollers for high speed performance or specialty doughs.



### HEADQUARTERS

AMF Bakery Systems  
2115 West Laburnum Avenue  
Richmond, Virginia 23227  
1-800-225-3771  
or 804-355-7961  
FAX : 1-804-342-9724

### EUROPEAN OPERATION

West Park Ring Road  
Leeds LS16 6QQ England  
Tel. : 1132-787110  
Fax : 1132-741415  
sales@amfbakery.com

FOR MORE INFORMATION PLEASE CALL YOUR ACCOUNT MANAGER OR

**1-800-BAKERS-1**  
www.amfbakery.com

## Free Manuals Download Website

<http://myh66.com>

<http://usermanuals.us>

<http://www.somanuals.com>

<http://www.4manuals.cc>

<http://www.manual-lib.com>

<http://www.404manual.com>

<http://www.luxmanual.com>

<http://aubethermostatmanual.com>

Golf course search by state

<http://golfingnear.com>

Email search by domain

<http://emailbydomain.com>

Auto manuals search

<http://auto.somanuals.com>

TV manuals search

<http://tv.somanuals.com>