



ADM

40

50

60

80

90

115

135

**Installation
User and
Service Manual**

A.O. SMITH
**WATER PRODUCTS
COMPANY**

A DIVISION OF A. O. SMITH CORPORATION



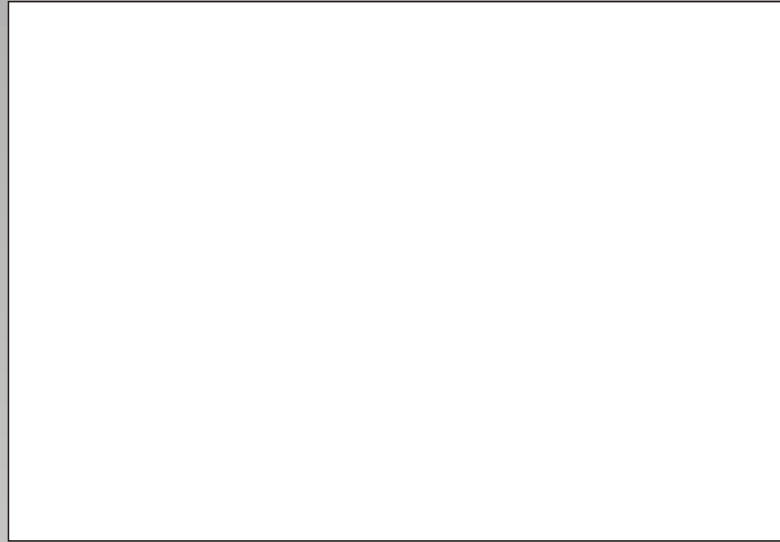

your installer





Read this manual carefully

Warning

Read this manual carefully before starting up the water heater. Failure to read this manual and to follow the instructions in this manual may lead to accidents, personal injury, and damage to the appliance.

Copyright © 2008 A.O. Smith Water Products Company

All rights reserved.

Nothing from this publication may be copied, reproduced and/or published by means of printing, photocopying or by whatsoever means, without the prior written approval of A.O. Smith Water Products Company.

A.O. Smith Water Products Company reserves the right to modify specifications stated in this manual.

Trademarks

Any brand names mentioned in this manual are registered trademarks of their respective owners.

Liability

A.O. Smith Water Products Company accepts no liability for claims from third parties arising from improper use other than that stated in this manual and in accordance with the General Conditions registered at the Eindhoven Chamber of Commerce.

Refer further to the General Conditions. These are available on request, free of charge.

Although considerable care has been taken to ensure a correct and suitably comprehensive description of all relevant components, the manual may nonetheless contain errors and inaccuracies.

Should you detect any errors or inaccuracies in the manual, we would be grateful if you would inform us. This helps us to further improve our documentation.

More information

If you have any comments or queries concerning any aspect related to the appliance, then please do not hesitate to contact:

A.O. Smith Water Products Company

PO Box 70

5500 AB Veldhoven

Netherlands

Telephone: (free) 0870 - AOSMITH
0870 - 267 64 84

General: +31 40 294 25 00

Fax: +31 40 294 25 39

E-mail : info@aosmith.nl

Website: www.aosmithinternational.com

In the event of problems with connecting to the gas, electricity or water supply, please contact your installation's supplier/installation engineer .

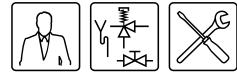

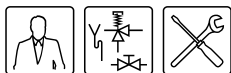
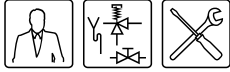

Table of contents

1	Introduction	7
1.1	About the appliance	7
1.2	What to do if you smell gas-	7
1.3	Regulations	7
1.4	Target groups	8
1.5	Maintenance-	8
1.6	Forms of notation	8
1.7	Overview of this document	9
2	Working principle of the appliance-	11
2.1	Introduction	11
2.2	General working principle of the appliance	11
2.3	The appliance's heating cycle	12
2.4	Protection for the appliance	12
2.5	Safety of the installation	13
3	Installation	15
3.1	Introduction	15
3.2	Packaging	15
3.3	Ambient conditions-	15
3.4	Technical specifications	17
3.5	Installation diagram	21
3.6	Water connections, Vented-	22
3.7	Water connections, Unvented	23
3.8	Gas connection	24
3.9	Chimney flue-	25
3.10	Electrical connection	26
3.11	Checking the supply pressure and burner pressure	28
4	Conversion to a different gas category	33
4.1	Conversion to different category ADM 40 through 115	34
4.2	Conversion to a different gas category ADM 135	36
5	Filling-	41
5.1	Filling unvented installations	42
5.2	Filling vented installations	42
6	Draining	43
6.1	Draining unvented installations	44
6.2	Draining vented installations	45
7	The control panel-	47
7.1	Introduction	47
7.2	Control panel	47
7.3	Explanation of icons	47
7.4	ON/OFF switch	47
7.5	Control thermostat	47
7.6	Burner control reset button	48
7.7	Flue gas thermostat reset button	48

Table of contents

8	Status of the appliance	49
8.1	Introduction	-49
8.2	Operating modes	-49
8.3	Error conditions	-49
9	Starting and running	51
9.1	Introduction	-51
9.2	Starting the appliance	-51
9.3	The appliance's heating cycle	-51
10	Shutting down	53
10.1	Introduction	-53
10.2	Shutting down the appliance for a brief period (OFF mode)	-53
10.3	Isolating the appliance from the mains	-53
10.4	Shutting the appliance down for a long period	-53
11	Troubleshooting	55
11.1	Introduction	-55
11.2	Error conditions	-55
11.3	Troubleshooting table for general errors	-56
11.4	ADM Troubleshooting table - no hot water	-57
11.5	Troubleshooting table - 'insufficient hot water'	-59
12	Performing maintenance	61
12.1	Introduction	-61
12.2	Preparation for maintenance	-61
12.3	Water-side maintenance	-62
12.4	Gas-side maintenance	-63
12.5	Finalising maintenance	-64
13	Warranty (certificate)	65
13.1	General warranty	-65
13.2	Tank warranty	-65
13.3	Conditions for Installation and use	-65
13.4	Exclusions	-66
13.5	Scope of the warranty	-66
13.6	Claims	-66
13.7	Obligations of A.O. Smith	-66
14	Appendices	67
14.1	Introduction	-67
14.2	Electrical Diagrams ADM	-68



1 Introduction

1.1 About the appliance

This manual describes how to install, service and use the ADM appliance. The ADM appliance is a gas-fired open boiler without fan. ADM appliances are equipped with a flue gas backflow safeguard.

The ADM is an appliance of type B_{11BS}.

The information in this manual applies to types: ADM 40, ADM 50, ADM 60, ADM 80, ADM 90, ADM 115 and ADM 135.

The appliance has been manufactured and equipped in accordance with the European standard for gas-fired storage water heaters for the production of domestic hot water (EN 89). The appliances are therefore compliant with the European Directive for Gas Appliances, and are entitled to bear the CE mark.



Warning

Read this manual carefully before starting up the water heater. Failure to read the manual and to follow the printed instructions may lead to personal injury and damage to the appliance.

1.2 What to do if you smell gas

Warning

If there is a **gas smell**:

No naked flames! No smoking!

Avoid causing sparks! Do not use any electrical equipment or switch, i.e. no telephones, plugs or bells!

Open windows and doors!

Shut off the mains gas supply valve!

Warn occupants and leave the building!

After leaving the building, alert the gas distribution company or your installation engineer.

1.3 Regulations

As the (end) user, installation engineer or service and maintenance engineer, you must ensure that the entire installation complies, as a minimum, with the official local:

- building regulations;
- energy supplier's directives for existing gas installations;
- directives and technical guidelines for natural gas installations;
- safety requirements for low-voltage installations;
- regulations governing the supply of drinking water;
- regulations governing ventilation in buildings;
- regulations governing the supply of air for combustion;
- regulations governing the discharge of products of combustion;
- requirements for installations that consume gas;
- regulations governing indoor waste water disposal;
- regulations imposed by fire brigade, power companies and municipality.



Furthermore, the installation must comply with the manufacturer's instructions.



Note

Later amendments and/or additions to all regulations, requirements and guidelines published on or prior to the moment of installing, will apply to the installation.

1.4 Target groups

The three target groups for this manual are:

- (end) users;
- installation engineers;
- service and maintenance engineers.

Symbols on each page indicate the target groups for whom the information is intended. See the table.

Target group symbols

Symbol	Target group
	(End) user
	Installation engineer
	Service and maintenance engineer

1.5 Maintenance

A service should be carried out at least once a year, both on the water side and on the gas side. Maintenance frequency depends, among other things, on the water quality, the average burning time per day and the set water temperature.



Note

To determine the correct maintenance frequency, it is recommended to arrange for the service and maintenance engineer to check the appliance on both the water and gas side within three months following installation. Based on this check, the best maintenance frequency can be determined.



Note

Regular maintenance extends the service life of the appliance.



Note

Both the end user and the service and maintenance engineer are responsible for regular maintenance. They will need to establish clear agreements on this.



Note

If the appliance is not regularly maintained, the warranty will become void.

1.6 Forms of notation

The following notation is used in this manual:



Note

Important information.



Caution

Ignoring this information can lead to the appliance being damaged.



Warning



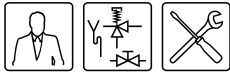



























Failure to carefully read this information may lead to personal injury and serious damage to the appliance.



1.7 Overview of this document

The table provides an overview of the contents of this document.

Contents of this document

Chapter	Target groups	Description
Working principle of the appliance	  	This chapter describes how the appliance functions.
Installation	 	This chapter describes the installation activity to be completed before you actually start up the appliance.
Filling	  	This chapter describes how to fill the appliance.
Draining	  	This chapter describes how to drain the appliance.
The control panel	  	This chapter describes the general operation of the appliance and explains how to use the control panel.
Status of the appliance	  	This chapter describes the status (mode or condition) that the appliance may have, and possible actions to take.
Starting and running	  	This chapter describes how to start the appliance running. The general heating cycle of the appliance is also described.
Shutting down	  	This chapter describes how to shut the appliance down for a brief or long period of time.
Troubleshooting	  	This chapter is mainly intended for the installation engineer and the service and maintenance engineer. It describes appliance errors. A table is included stating potential symptoms, causes and solutions. End users may also refer to this chapter for additional information about the appliance.
Performing maintenance		This chapter sets out the maintenance tasks to be carried out during a service.
Warranty (certificate)	  	This chapter states the warranty terms and conditions.



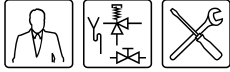

2 Working principle of the appliance

2.1 Introduction

Topics covered in this chapter:

- [General working principle of the appliance;](#)
- [The appliance's heating cycle;](#)
- [Protection for the appliance;](#)
- [Safety of the installation.](#)

2.2 General working principle of the appliance

The figure shows a cut-away view of the appliance.

Cut-away view of the appliance

Legend

Only applicable numbers are mentioned.

- 2. hot water outlet
- 6. control panel
- 8. combustion chamber
- 9. anode
- 10. tank
- 11. heat exchanger
- 12. inspection and cleaning opening
- 14. cold water inlet
- 15. drain valve
- 16. gas control
- 20. spark igniter
- 21. flame probe
- 22. chimney pipe
- 24. insulation layer
- 33. draught diverter
- 34. flue gas sensor
- 35. radiation shield/condensation tray
- 36. bar burners/burner tray
- 37. flue gas thermostat
- 38. safety thermostat sensor
- 39. high-limit thermostat sensor
- 40. burner control
- 41. control thermostat
- 42. high-limit thermostat
- 43. safety thermostat
- 44. frost thermostat
- 45. control thermostat sensor
- 46. frost thermostat sensor

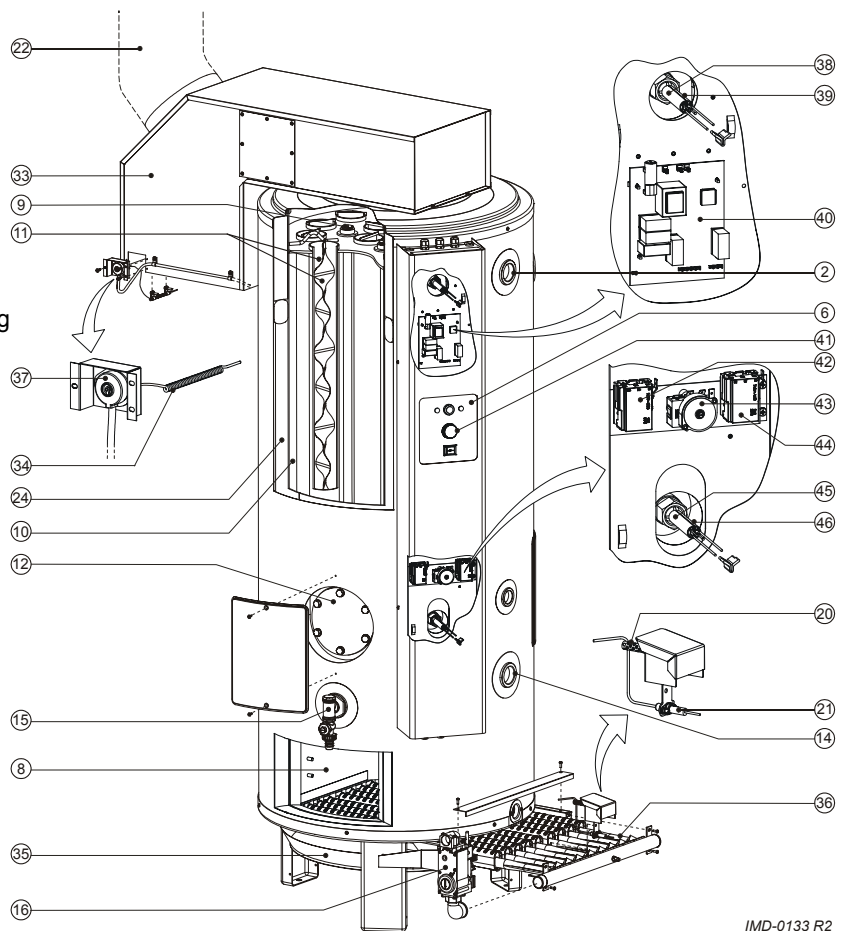

IMD-0133 R2



In this appliance, the cold water enters the bottom of the tank through the cold water inlet (14). The heat of combustion is conducted to the water by the combustion chamber (8) and heat exchanger (11). The heated tap water leaves the tank through the hot water outlet (2). Once the appliance is completely filled with water, it will constantly be under mains water pressure. When hot water is drawn from the appliance, it is immediately replenished with cold water.

The gas required for combustion flows via the gas control (16) into the manifold. Orifices are mounted in the manifold. The gas is injected into the burner bars at pressure from these orifices (36). The burner bars together form the burner tray. The injection of gas into the burner bars also draws in the primary air required for combustion. The narrow opening in the orifice causes the gas flow to accelerate. This in turn causes a partial vacuum. It is this partial vacuum that draws in the air (the Venturi effect). Additional air is drawn in through the opening in the burner tray.

The hot surface igniter (20) ensures ignition of the gas/air mixture.

The flue gases released by this combustion are led through the flue tubes (part of 11). Flue baffles (part of 11) are mounted in the flue tubes. These retard the flow of the flue gases, thereby increasing the thermal efficiency of the appliance.

The flue gases are vented from the appliance via the draught diverter (33).

A radiation shield/condensation tray (35) is mounted below the burner tray. This prevents overheating of the floor area below the appliance, as well as serving as a collection tray for condensation water.

The insulation layer (24) prevents heat loss. The inside of the tank is enamelled to protect against corrosion. The anodes (9) offer extra protection.

2.3 The appliance's heating cycle

The entire appliance is controlled by the burner control (40) and the control thermostat (41) or frost thermostat (44). The control thermostat and frost thermostat both independently measure the water temperature (T_{water}). The appliance's heating cycle is activated as soon as T_{water} falls below the threshold value (T_{set}). The value of T_{set} depends on the selected mode of the appliance (8.2 "Operating modes"). When the appliance is in OFF mode (frost protection), this value is determined by the frost thermostat (threshold value = 20°C). When the appliance is in 'ON mode', the threshold value can be set via the control thermostat ($\pm 40^{\circ}\text{C}$ - $\pm 70^{\circ}\text{C}$).

As soon as T_{water} falls below T_{set} , the relevant thermostat (control or frost) will close, and the burner control will register demand. The gas control (16) is opened, and the gas is mixed with air. This mixture is ignited by the hot surface igniter (20) and the water is heated. As soon as T_{water} gets higher than T_{set} , the thermostat opens again. The demand will cease, and the burner control will stop the heating cycle.

The thermostats have a certain margin both when closing and opening. We refer to this margin as the hysteresis. The hysteresis cannot be adjusted.

2.4 Protection for the appliance

2.4.1 Introduction

The burner control monitors the water temperature by means of thermostats and ensures safe combustion. This takes place using:

- the [Water temperature protection](#);
- the [Flue gas backflow safeguard](#);
- the [Flame probe](#).

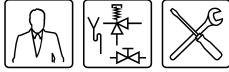

2.4.2 Water temperature protection

By means of the frost, high-limit and safety thermostats, the burner control monitors three temperatures that are important for safety. The table explains the working principle of the thermostats with sensors.

Temperature protection

Protection	Description
Frost thermostat	When the frost thermostat sensor (46) measures a temperature of 20°C or less, the heating cycle (2.3 "The appliance's heating cycle") will start.
High-limit thermostat	When the high-limit thermostat sensor (39) measures a temperature higher than 84°C, the high-limit thermostat will open. The heat demand is terminated and the burner control halts the heating cycle until the high-limit thermostats close once more. At that moment the burner control will reset the appliance and the heating cycle will restart. The high-limit safeguard serves to prevent overheating and/or excessive formation of scale in the appliance.
Safety thermostat	When the safety thermostat sensor (38) measures a temperature higher than 93°C, the safety thermostat will open. The heat demand is terminated and the burner control will immediately halt the heating cycle. The burner control will go into a lockout error state. This must be manually reset before the appliance can resume operation.

2.4.3 Flue gas backflow safeguard

The flue gases are discharged to the outside via the draught diverter (33) and the flue (22). To prevent the flue gases from flowing back into the boiler room, the discharge ducting is monitored by a feature called the Thermal Reflux Safeguard (TRS). This uses a flue gas thermostat (37) with a flue gas thermostat sensor (34) that are located in the draught diverter. Under normal circumstances this sensor will register the ambient temperature.

However, if the chimney is not drawing sufficiently (for example, due to a blockage in the chimney), the flue gases will 'reflux' and flow back past the flue gas thermostat sensor. The sensor will then detect an excessive temperature and the flue gas thermostat will open. The demand will cease, and the burner control will immediately stop the heating cycle. The flue gas thermostat will also lock out. It must be manually reset before the appliance can resume operation.

2.4.4 Flame probe

To ensure that no gas can flow when there is no combustion, the water heater is fitted with a flame probe (21). The burner control uses the ionisation-detecting properties of this probe for flame detection. The burner control closes the gas valve the instant it determines that there is a gas flow but no flame is present.

2.5 Safety of the installation

In addition to the appliance's standard built-in safety monitoring, the appliance must also be protected by an expansion vessel, expansion valve, pressure reducing valve, non-return valve and a T&P valve.

The use of an expansion vessel, expansion valve and/or pressure reducing valve depends on the type of installation: unvented or vented.

2.5.1 Inlet combination and pressure-reducing valve

In addition to the appliance's standard built-in safety monitoring, the appliance must also be protected by an expansion vessel, expansion valve, pressure reducing valve, non-return valve and a T&P valve.

The use of an expansion vessel, expansion valve and/or pressure reducing valve depends on the type of installation: unvented or vented.

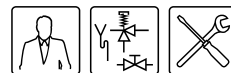

2.5.2 Unvented installation

With an unvented installation, an expansion valve and expansion vessel prevent the buildup of excessive pressure in the tank. This prevents damage being caused to the enamelled coating (in the appliance) or to the tank. A non-return valve prevents excessive pressure buildup in the water supply system. This valve also prevents water from flowing backwards from the tank into the cold water supply system. The pressure reducing valve protects the installation against an excessively high water supply pressure (> 8 bar). These components are fitted to the cold water pipe (3.6 "Water connections, Vented").

2.5.3 Vented installation

With vented installation, excess pressure is taken up by the open cold water head tank. The head height of the tank determines the working pressure in the water heater, which may not exceed 8 bar. The installation must also be fitted with a vent pipe from the hot water pipe (3.6.3 "Hot water side"), which opens into the cold water tank.

2.5.4 T&P valve

A T&P valve is only mandatory in an unvented installation. However, A.O. Smith also recommends the use of a T&P valve in vented installations.

A T&P (Temperature and Pressure Relief) valve monitors the pressure in the tank and the water temperature at the top of the tank. If the pressure in the tank becomes excessive (> 10 bar) or the water temperature is too high (> 97°C), the valve will open. The hot water can now flow out of the tank. Because the appliance is under water supply pressure, cold water will automatically flow into the tank. The valve remains open until the unsafe situation has been rectified. The appliance is fitted standard with a connecting point for a T&P valve (3.7.3 "Hot water side").



3 Installation

Warning

Installation work should be carried out by an approved installation engineer in compliance with the general and local regulations imposed by the gas, water and power supply companies and the fire service.

The appliance may only be installed in a room that complies with the requirements stated in national and local ventilation regulations ([1.3 "Regulations"](#)).

3.1 Introduction

This chapter describes the installation activities to be carried out before the appliance may be started up ([9 "Starting and running"](#)), in particular:

- [Packaging](#);
- [Ambient conditions](#);
- [Technical specifications](#);
- [Water connections, Vented](#);
- [Water connections, Vented](#);
- [Gas connection](#);
- [Chimney flue](#);
- [Electrical connection](#);
- [Checking the supply pressure and burner pressure](#).

For a possible conversion to a different gas category, see conversion ([4 "Conversion to a different gas category"](#)).

3.2 Packaging

To avoid damaging the appliance, remove the packaging carefully.

We recommend unpacking the appliance at or near its intended location.

Caution

The appliance may only be manoeuvred in an upright position. Take care that the appliance is not damaged after unpacking.

3.3 Ambient conditions

Caution

The appliance may not be used in rooms where chemical substances are stored or used, due to the risk of explosion and/or corrosion of the appliance. Some propellants, bleaching agents, degreasing agents etc. disperse vapours which are explosive and/or which cause accelerated corrosion. If the appliance is used in a room in which such substances are present, the warranty will be void.

ADM appliances are open appliances and may only be installed in an open boiler room. Their type is B₁BS.

3.3.1 Air humidity and ambient temperature

The boiler room must be frost-free, or be protected against frost. The table shows the environmental conditions that must be adhered to for correct functioning of the electronics present in the appliance to be guaranteed.

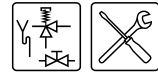

Air humidity and ambient temperature specifications

Air humidity and ambient temperature	
Air humidity	max. 93% RV at +25°C
Ambient temperature	Functional: $0 \leq T \leq 60^{\circ}\text{C}$

3.3.2 Maximum floor load

In connection with the appliance's weight, take account of the maximum floor loading, refer to the table.

Weight of the appliance filled with water						
ADM 40	ADM 50	ADM 60	ADM 80	ADM 90	ADM 115	ADM 135
504 kg	578 kg	507 kg	573 kg	522 kg	523 kg	581 kg

3.3.3 Water composition

The appliance is intended for heating drinking water. The drinking water must comply with the regulations governing drinking water for human consumption. The table gives an overview of the specifications.

Water specifications

Water composition	
Hardness (alkaline earth ions)	> 1.00 mmol/l: <ul style="list-style-type: none"> • German hardness > 5.6° dH • French hardness > 10.0° fH • English hardness > 7.0° eH
Conductivity	> 125 $\mu\text{S/cm}$
Acidity (pH value)	$7.0 < \text{pH value} < 9.5$

Note

If the water specifications deviate from those stated in the table, then the tank protection cannot be guaranteed ([13 "Warranty \(certificate\)"](#)).

3.3.4 Working clearances

For access to the appliance, it is recommended that the following clearances are observed (see figure):

- AA: around the appliance's control column and cleaning openings: 100 cm.
- BB: all sides of the appliance: 50 cm.
- Above the appliance (room to replace the anodes):
 - 100 cm if using fixed anodes, or
 - 50 cm if using flexible anodes.

If the available clearance is less than 100 cm, flexible magnesium anodes may be ordered.

Note

When installing the appliance, be aware that any leakage from the tank and/or connections can cause damage to the immediate environment or floors below the level of the boiler room. If this is the case, the appliance should be installed above a wastewater drain or in a suitable metal leak tray.

The leak tray must have an appropriate wastewater drain and must be at least 5cm deep with a length and width at least 5cm greater than the diameter of the appliance.



Working clearances

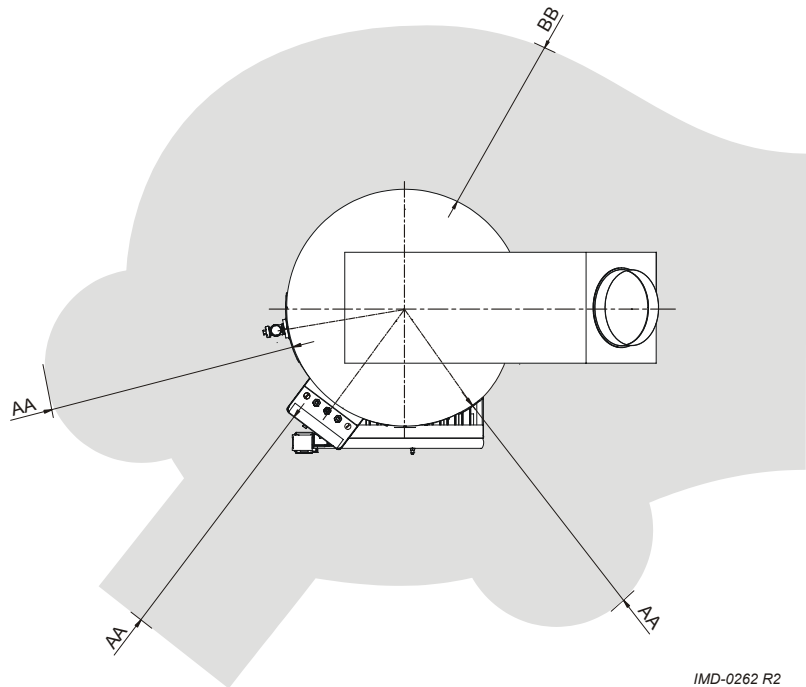

IMD-0262 R2

3.4 Technical specifications

The appliance is supplied without accessories. Check the dimensions ([3.4.1 "Dimensions of the appliance"](#)), gas data ([3.4.3 "Gas data"](#)) and other specifications ([3.4.2 "General and electrical specifications"](#)) of any accessories you plan to use.

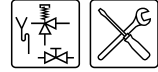

3.4.1 Dimensions of the appliance

Plan and elevation of the appliance

Legend
See the table.

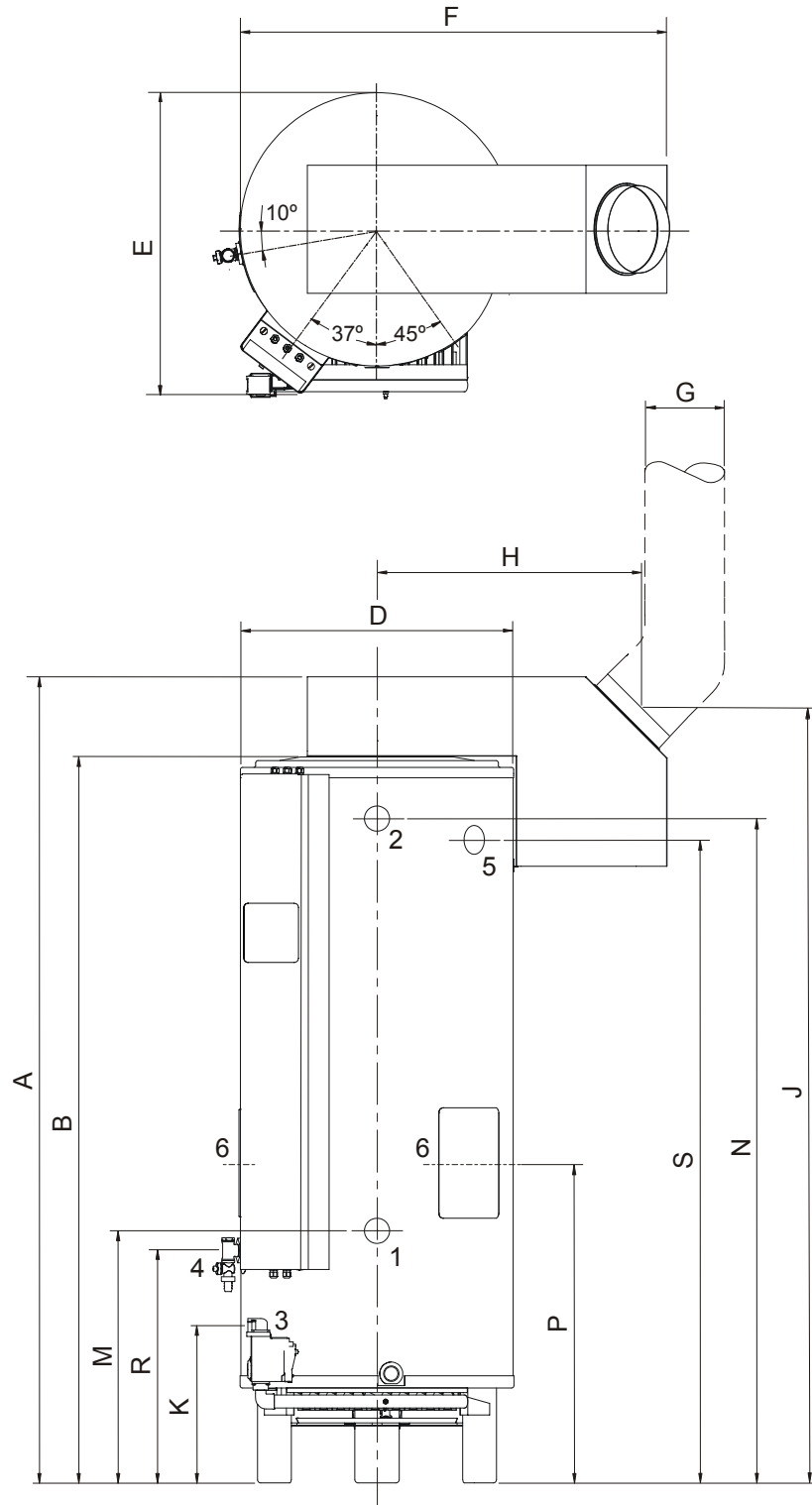

IMD-0135 R2

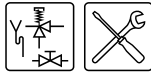

Dimensions (all measurements in mm unless otherwise indicated)

Dimension	Description	ADM 40	ADM 50	ADM 60	ADM 80	ADM 90	ADM 115	ADM 135
A	Total height	1900	2100	1900	2100	2000	2085	2085
B	Height of top of appliance	1760	1960	1760	1960	1795	1870	1870
D	Appliance diameter	710	710	710	710	710	710	710
E	Depth	800	800	800	800	800	800	800
F	Width	1100	1100	1100	1100	1105	1105	1105
G	Diameter of chimney flue	150	150	180	180	225	225	225
H	Heart appliance / Heart chimney flue	660	660	660	660	675	675	675
J	Height of chimney flue	1840	2040	1840	2040	1935	2010	2010
K	Height of gas connection	400	400	400	400	400	400	205
M	Height of cold water supply	565	565	565	565	575	650	650
N	Height of hot water outlet	1605	1810	1605	1810	1640	1715	1715
P	Height of cleaning opening	730	730	730	730	740	825	855
R	Height of drain valve connection	500	515	500	515	525	600	595
S	Height of T&P valve connection	1550	1760	1550	1760	1595	1660	1660
1	Cold water supply connection (male)	R1 ^{1/2}	R1 ^{1/2}	R1 ^{1/2}	R1 ^{1/2}	R1 ^{1/2}	R1 ^{1/2}	R1 ^{1/2}
2	Hot water outlet connection (female)	Rp1 ^{1/2}	Rp1 ^{1/2}	Rp1 ^{1/2}	Rp1 ^{1/2}	Rp1 ^{1/2}	Rp1 ^{1/2}	Rp1 ^{1/2}
3	Gas control connection (female)	Rp ^{3/4}	Rp ^{3/4}	Rp ^{3/4}	Rp ^{3/4}	Rp ^{3/4}	Rp ^{3/4}	Rp1
4	Drain valve connection (female)	Rp1 ^{1/2}	Rp1 ^{1/2}	Rp1 ^{1/2}	Rp1 ^{1/2}	Rp1 ^{1/2}	Rp1 ^{1/2}	Rp1 ^{1/2}
5	T&P valve connection (female)	1 - 11.5 NPT	1 - 11.5 NPT	1 - 11.5 NPT	1 - 11.5 NPT	Rp1 ^{1/2}	Rp1 ^{1/2}	Rp1 ^{1/2}
6	Cleaning/inspection opening	Ø 100	Ø 100	Ø 100	Ø 100	Ø 100	Ø 100	Ø 100

3.4.2 General and electrical specifications

General and electrical specifications

DESCRIPTION	Unit	ADM 40	ADM 50	ADM 60	ADM 80	ADM 90	ADM 115	ADM 135
Capacity	litres	309	357	298	335	278	253	252
Maximum operating pressure	bar	8	8	8	8	8	8	8
Empty weight	kg	195	221	209	238	244	270	329
Heating-up time $\Delta T = 45^{\circ}\text{C}$	minutes	30	26	19	17	12	8	7
Number of anodes	-	2	2	2	3	3	4	4
Number of bar burners/orifices	-	3	4	5	7	7	9	6
Number of flue tubes/flue baffles	-	5	6	7	9	12	16	17
Electrical power consumption	W	30	30	30	30	30	30	60
Supply voltage (-15% +10% VAC)	volts	230	230	230	230	230	230	230
Mains frequency	Hz ($\pm 1\text{Hz}$)	50	50	50	50	50	50	50
IP class	-	30	30	30	30	30	30	30

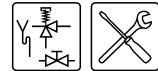

3.4.3 Gas data

Gas data

Description $\text{H}_{2\text{H}3+}$	Unit	ADM 40	ADM 50	ADM 60	ADM 80	ADM 90	ADM 115	ADM 135
Gas category 2H: General								
Orifice diameter	mm	3.20	3.20	3.10	2.95	3.20	3.20	3.90
(1) = Blank plate (2) = Burner pressure regulator (3) = High/low regulator	1, 2 or 3	2	2	2	2	2	2	2
Gas category G20 - 20 mbar								
Nominal load (gross calorific value)	kW	42.2	56.5	66.4	82.5	98.3	126.6	143.4
Nominal output	kW	32.3	42.8	50.2	62.4	74.3	95.8	109.8
Supply pressure	mbar	20	20	20	20	20	20	20
Burner pressure	mbar	8.5	8.5	8.5	8.5	8.5	8.5	11.3
Gas consumption (*)	m ³ /h	4.0	5.4	6.3	7.9	9.4	12.1	13.7
Gas category 3+: General								
Orifice diameter	mm	1.70	1.70	1.70	1.50	1.70	1.70	2.25
(1) = Blank plate (2) = Burner pressure regulator (3) = High-low control	1, 2 or 3	1	1	1	1	1	1	3
Gas category G30 - 30 mbar								
Nominal load (gross calorific value)	kW	41.6	55.3	68.2	80.7	96.1	123.5	138.4
Nominal output	kW	32.6	42.8	52.8	62.6	74.5	95.8	108.5
Supply pressure	mbar	30	30	30	30	30	30	30
Burner pressure (†)	mbar	-	-	-	-	-	-	-
Gas consumption (*)	kg/h	3.0	4.0	5.0	5.9	7.0	9.0	10.1
Gas category G31 - 37 mbar								
Nominal load (gross calorific value)	kW	38.4	51.1	63.3	77.7	89.6	113.0	130.1
Nominal output	kW	30.0	39.5	48.9	60.1	69.2	87.4	101.7
Supply pressure	mbar	37	37	37	37	37	37	37
Burner pressure (†)	mbar	-	-	-	-	-	-	-
Gas consumption (*)	kg/h	2.7	3.7	4.5	5.6	6.4	8.1	9.3
(*) Based on 1013.25 mbar and 15 °C.								
(†) If using a blank plate instead of a burner pressure regulator, it is assumed that the burner pressure is equal to the supply pressure. In practice, however, the burner pressure will be lower.								



3.5 Installation diagram

3.5.1 Installation

This figure shows the installation diagram. This diagram is used in the sections in which the actual connection process is described.

Installation diagram

Legend

Only applicable numbers are mentioned.

1. pressure reducing valve (mandatory)
3. T&P valve (mandatory)
4. stop valve (recommended)
5. non-return valve (mandatory)
6. circulation pump (optional)
7. top to bottom circulation pump (optional)
9. drain valve
10. manual gas valve (mandatory)
11. service stop valve (mandatory)
12. temperature gauge (recommended)
14. hot water draw-off points
15. expansion valve (mandatory)
16. expansion vessel (mandatory)
17. 3-way aeration valve (recommended)
18. water tank
19. float valve
- A. cold water supply
- B. hot water supply
- C. circulation pipe
- D. gas supply
- E. overflow pipe
- H. overflow pipe

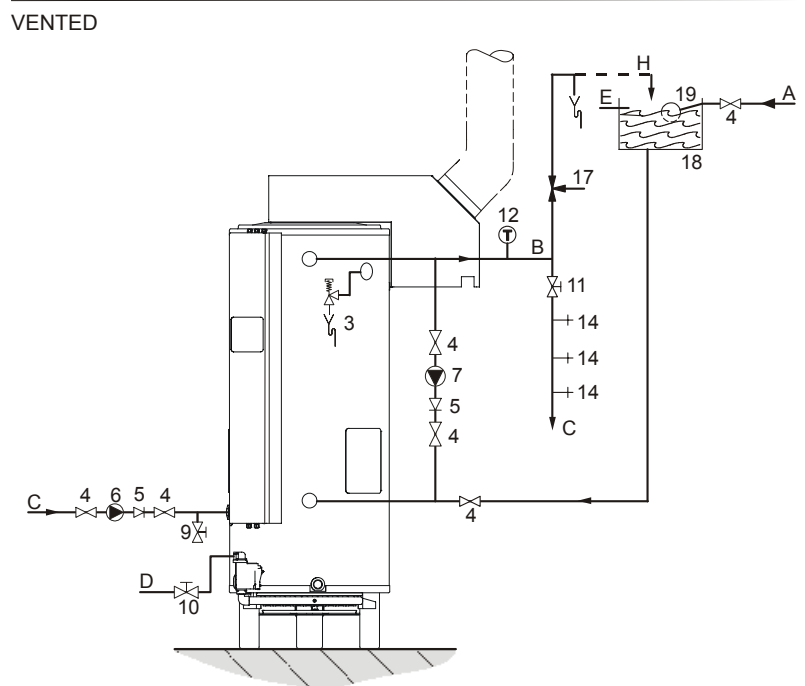
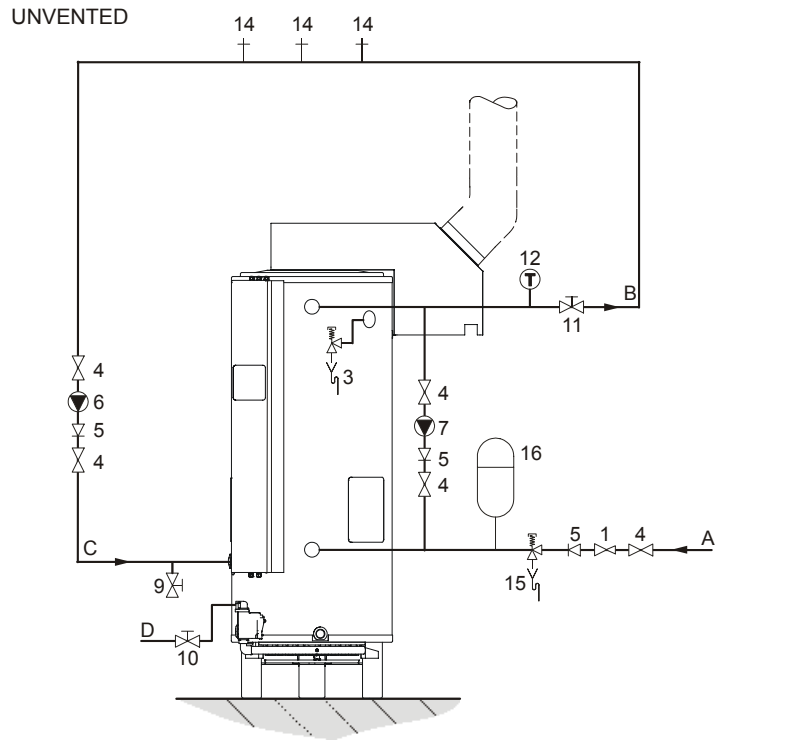

IMD-0466 R0

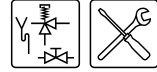

3.6 Water connections, Vented



Warning

The installation should be carried out by an authorised installation engineer, in compliance with general and local regulations (1.3 "Regulations").

3.6.1 Cold water side

See (A) in the installation diagram (3.5 "Installation diagram").

1. Fit an approved stop valve (4) on the cold water side between the cold water head tank (18) and the appliance, as required by regulations (1.3 "Regulations").

3.6.2 Recirculation pipe

You can install a top to bottom circulation pump to prevent water stacking in the boiler.

1. Optional: depending on the draw-off pattern, fit a recirculation pipe (Ø 22 mm), a stop valve (11) and a top to bottom circulation pump (7).
2. Fit a non-return valve (5).
3. Fit a stop valve (11).

3.6.3 Hot water side

See (B) in the installation diagram (3.5 "Installation diagram").



Note

Insulating long hot water pipes prevents unnecessary energy loss.

1. Fit the T&P valve (3).
2. Optional: fit a temperature gauge (12) so you can check the temperature of the tap water.
3. Fit a stop valve (4) in the hot water outlet pipe, for use when servicing.
4. If a circulation pipe is required, continue further by installing the circulation pipe (3.6.5 "Circulation pipe").

3.6.4 Drain valve

1. Fit the standard drain valve (9) supplied with the appliance.
2. If applicable, fit a circulation pipe (3.6.5 "Circulation pipe").
If not, fit the blind threaded plug and gasket (C) supplied with the drain valve, as shown in the figure.

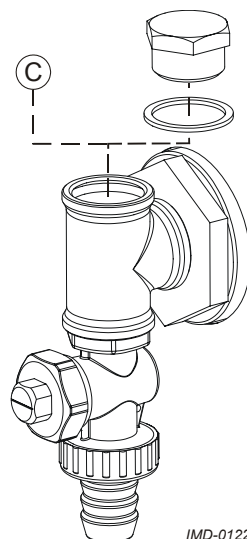

IMD-0122 R1



3.6.5 Circulation pipe

See (C) in the installation diagram (3.5 "Installation diagram").

If an immediate flow of hot water is required at draw-off points, a circulation pump can be installed. This improves comfort and reduces water wastage.

1. Fit a circulation pump (6) of the correct capacity for the length and resistance of the circulation system.
2. Fit a non-return valve (5) behind the circulation pump to guarantee the direction of circulation.
3. Fit two stop valves for service purposes (4).
4. Connect the circulation pipe to the T-piece at the drain valve (9) as shown in the drain valve figure (3.6.4 "Drain valve").

3.7 Water connections, Unvented

Warning

The installation should be carried out by an authorised installation engineer, in compliance with general and local regulations (1.3 "Regulations").

3.7.1 Cold water side

See (A) in the installation diagram (3.5 "Installation diagram").

1. Fit an approved stop valve (4) on the cold water side as required by applicable regulations (1.3 "Regulations").
2. The maximum working pressure of the appliance is 8 bar. Because the pressure in the water pipe at times can exceed 8 bar, you must fit an approved pressure-reducing valve (1).
3. Fit a non-return valve (5) and an expansion vessel (16).
4. Fit an expansion valve (15) and connect the overflow side to an open wastewater pipe.

3.7.2 Recirculation pipe

You can install a top to bottom circulation pump to prevent water stacking in the boiler.

1. Optional: depending on the draw-off pattern, fit a recirculation pipe (Ø 22 mm), a stop valve (11) and a top to bottom circulation pump (7).
2. Fit a non-return valve (5).
3. Fit a stop valve (11).

3.7.3 Hot water side

See (B) in the installation diagram (3.5 "Installation diagram").

Note

Insulating long hot water pipes will prevent unnecessary energy loss.

1. Optional: fit a temperature gauge (12) so you can check the temperature of the tap water.
2. Fit the T&P valve (3).
3. Fit a stop valve (11) in the hot water outlet pipe for servicing.

3.7.4 Drain valve

1. Fit the standard drain valve (9) supplied with the appliance.
2. If applicable, fit a circulation pipe (3.6.5 "Circulation pipe").
If not, fit the blind threaded plug and gasket (C) supplied with the drain valve, as shown in the figure.

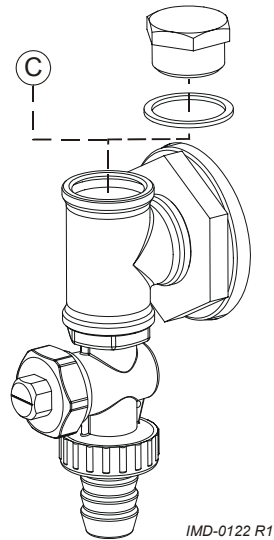

3.7.5 Circulation pipe

See (C) in the installation diagram (3.5 "Installation diagram").

If an immediate flow of hot water is required at draw-off points, a circulation pump can be installed. This improves comfort and reduces water wastage.

1. Fit a circulation pump (6) of the correct capacity for the length and resistance of the circulation system.
2. Fit a non-return valve (5) behind the circulation pump to guarantee the direction of circulation.
3. Fit two stop valves for service purposes (4).
4. Connect the circulation pipe to the T-piece at the drain valve (9) as shown in the drain valve figure (3.6.4 "Drain valve").

3.8 Gas connection

Warning

The installation should be carried out by an authorised installation engineer, in compliance with general and local regulations (1.3 "Regulations").

Caution

Make sure that the diameter and length of the gas supply pipe are large enough to supply sufficient capacity to the appliance.

See (D) in the installation diagram (3.5 "Installation diagram").

1. Fit a manual gas valve (10) in the gas supply pipe.
2. Blow the gas pipe clean before use.
3. Close the manual gas valve.
4. Fit the gas supply pipe to the gas control.

Warning

After fitting, check for leaks.



3.9 Chimney flue

Warning

The installation should be carried out by an authorised installation engineer, in compliance with general and local regulations (1.3 "Regulations").

3.9.1 Introduction

The separately-supplied draught diverter must be used when connecting the appliance to the chimney flue. The standard flue gas thermostat and sensor that are supplied must be fitted in the draught diverter.

3.9.2 Fitting the draught diverter

The draught diverter can be positioned according to preference. Once it is positioned, the draught diverter is secured to the top of the appliance using two screws (6), while it is also supported on a mounting bracket (1) attached to the side of the appliance. The mounting bracket parts can be found in the plastic bag attached behind the control column. The assembly procedure is as follows:

Installing the draught diverter

Legend

- 1 support bracket
- 2 holes to attach support bracket
- 3 screws for support bracket
- 4 holes to attach draught diverter
- 5 sealing ring
- 6 screws for draught diverter
- 7 45° bend
- 8 chimney pipe

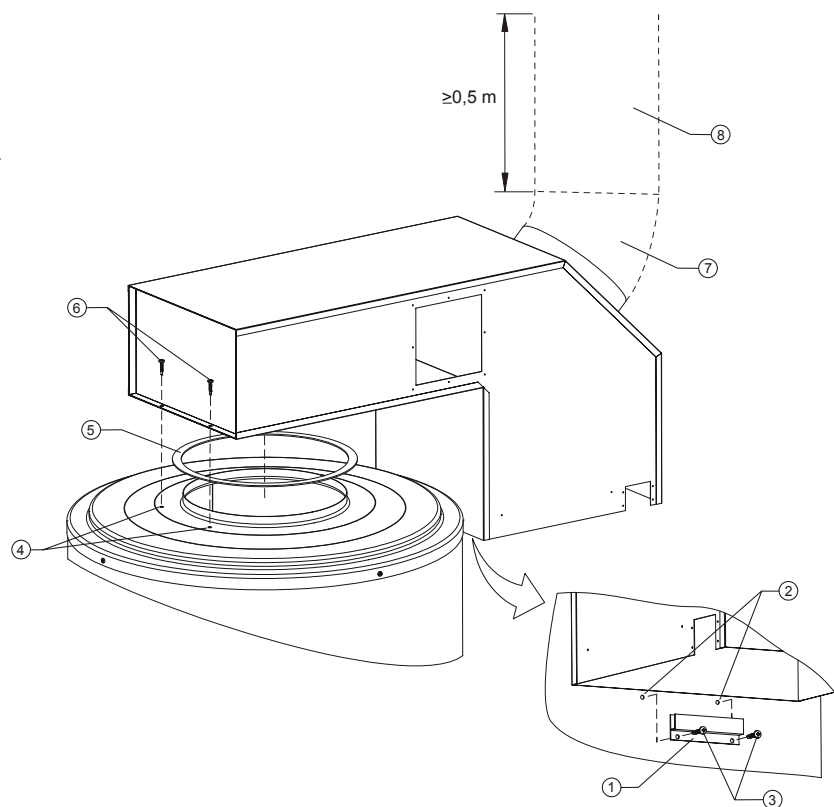

IMD-0123 R1

1. Take the mounting bracket out of the bag.
2. Fit the mounting bracket (1) in such a way that it properly supports the draught diverter.
3. Drill two holes (2) (3.2 mm bit) for the mounting bracket screws.
4. Screw the mounting bracket tightly to the appliance.
5. Place the draught diverter in the mounting bracket, and mark the centres for the two holes (4) to be drilled in the top side of the appliance. Remove the draught diverter from the appliance.
6. Now drill two holes (4) into the top of the appliance (3.2 mm bit).
7. Place the sealing ring (5) on the appliance.

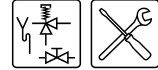

8. Screw the draught diverter tightly in place.
9. Fit:
 - a 45° bend (7) onto the outlet of the draught diverter, followed by:
 - a corrosion-resistant vertical chimney pipe (8) of at least 0.5 metres in length,
 - the remaining flue components.

**Note**

Use flue gas discharge materials that comply with the regulations (1.3 "Regulations").

**Note**

Make sure that the chimney discharges into an area approved for this type of appliance.

3.9.3 Flue gas thermostat assembly

At the top of the control column there is a plastic bag containing the flue gas thermostat with the sensor plus the associated fastenings. The cable from the sensor has already been connected to the control column. The thermostat/bracket and sensor have yet to be fitted inside the draught diverter.

**Warning**

If the flue gas thermostat is not (or is incorrectly) fitted/connected, the flue gas discharge will not be protected. An incorrectly fitted chimney can cause flue gases to backflow into the boiler room.

Flue gas safety

Legend

- 1 bracket
- 2 sensor
- 3 attachment brackets
- 4 cable

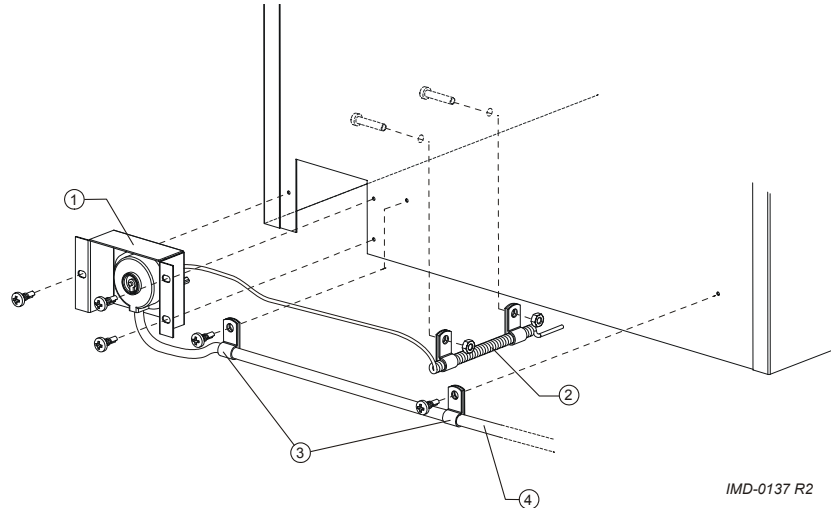

1. Fit the flue gas thermostat as follows:
2. Take the bracket (1) and flue gas sensor (2) from the packaging.
3. Place the bracket in de draught diverter and screw the bracket and the sensor firmly in place.
4. Bend the cable clips (3) around the flue gas thermostat lead (4).
5. Screw the cable clips (3) tightly into the draught diverter and the appliance.

3.10 Electrical connection

**Warning**

The installation should be carried out by an authorised installation engineer, in compliance with general and local regulations (1.3 "Regulations").



3.10.1 Preparations

Caution

The appliance is phase-sensitive. It is **absolutely essential** to connect the mains live (L) to the live of the appliance, and the mains neutral (N) to the neutral of the appliance.

Caution

There must also be **no potential difference** between neutral (N) and earth (\perp). If this is the case, then an isolating transformer must be applied in the supply circuit .

For more information or to order an isolating transformer, please contact A.O. Smith Water Products Company.

The figure shows a view of the electrical connector block, and the table shows the appropriate connections.

Connector block

Legend

- A. screws
- B. protective cap
- C. connector block

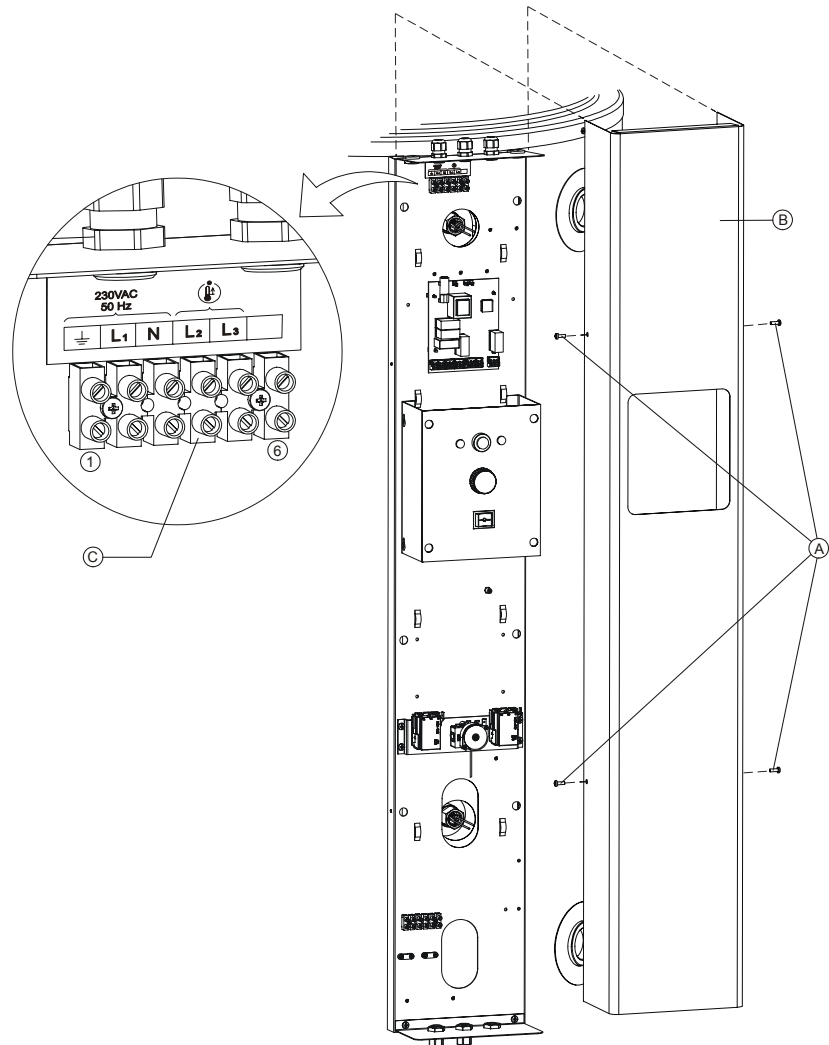

IMD-0134 R2

1. In preparation, first remove the protective cover from the control column:
2. Undo the 4 screws (A).
3. Remove the protective cover (B) from the electrical part.



The connector block (C) is now visible.

**Note**

Please consult (14.2 "Electrical Diagrams ADM") the appropriate electrical diagram for details of the connections of the electrical components.

Terminal block

Mains voltage			Flue Gas Thermostat		Unused
\perp	L ₁	N	L ₂	L ₃	-
1	2	3	4	5	6

3.10.2 Connecting the mains power

The appliance is supplied without a power cable and isolator.

**Note**

In order to receive electrical power, the appliance has to be connected to the mains power by means of a permanent electrical connection. A double-pole isolator with a contact gap of at least 3 mm must be fitted between this permanent connection and the appliance. The power cable must have cores of at least 3 x 1.0 mm².

**Warning**

Leave the appliance isolated until you are ready to start it up.

1. Feed the power cable through the metric strain relief to the top side of the control column.
2. Connect the earth (\perp), live (L₁) and neutral (N) of the power cable to terminals 1 through 3 in the connector block as stated in the table.
3. Turn the strain relief tight to clamp the lead.
4. If you do not need to make any more connections, fit the protective cover onto the control column.
5. Connect the power cable to the isolator.

3.11 Checking the supply pressure and burner pressure

**Note**

Before starting the appliance and/or checking the supply pressure and burner pressure, you must fill (5 "Filling") the appliance.

**Caution**

Before starting up for the first time or after conversion, you must always check the supply pressure and burner pressure.

**Note**

The easiest way to check the gas pressures is by using two pressure gauges. This procedure assumes that these two gauges are available.



Gas control for ADM 40 through 115

Legend

Only applicable numbers are mentioned.

1. burner pressure regulator
2. burner pressure regulator cap
3. burner pressure regulator adjustment screw
4. gas control connector
5. blank plate
6. supply pressure test nipple
7. gas control
8. manifold test nipple

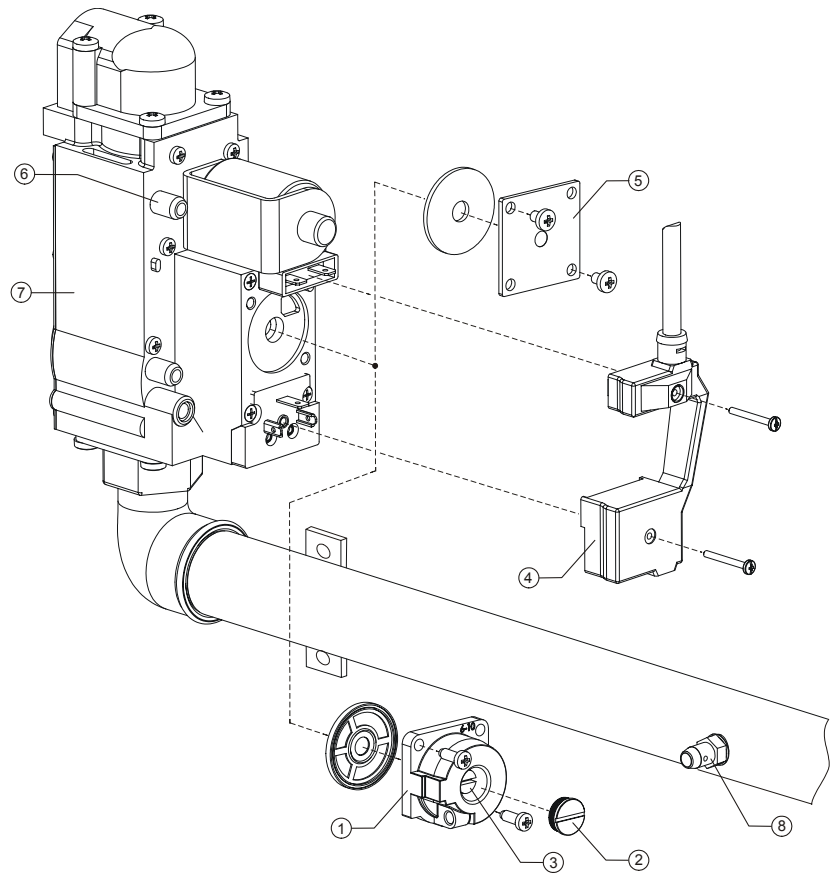

IMD-0127 R1

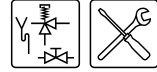

Gas control for ADM 135

Legend

Only applicable numbers are mentioned.

1. burner pressure regulator
2. burner pressure regulator cap
3. burner pressure regulator adjustment screw
6. supply pressure test nipple
7. gas control
8. manifold test nipple
9. high-low control

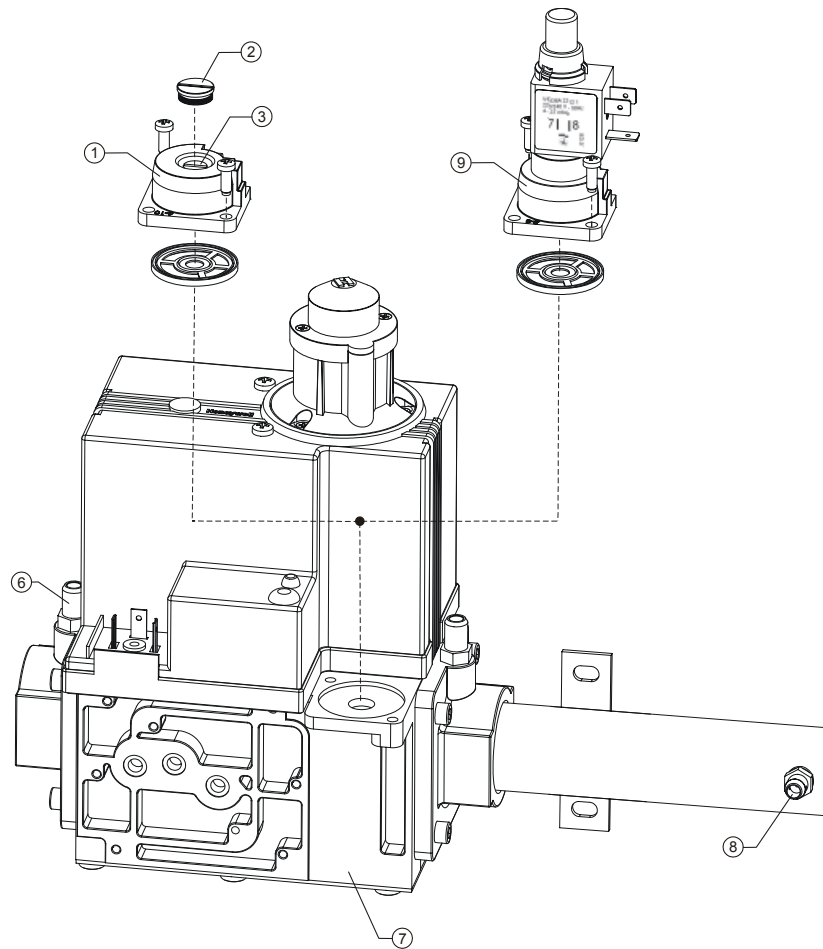

IMD-0129 R1

3.11.1 Preparations

1. Isolate the appliance from the power supply ([10.3 "Isolating the appliance from the mains"](#)).
2. There are two test nipples on the gas control. Test nipple (6) is used to check the supply pressure. The other test nipple on the gas control is not used. The manifold test nipple (8) is used to measure the burner pressure. Sealing screws are located inside the test nipples. Loosen both sealing screws by a few turns. Do not completely loosen them; they can be difficult to re-tighten.
3. Connect a pressure gauge to the manifold test nipple (8).
4. Open the gas supply and bleed the air from the mains gas supply via test nipple (6).
5. Connect a pressure gauge to the manifold test nipple (6) when gas starts to flow from this nipple.
6. Switch on the power to the appliance using the isolator on the appliance.
7. Set the control thermostat to the maximum temperature and start the appliance running by setting the ON/OFF switch to position I.
8. The heating cycle will start, and after a short time the burner tray will ignite.
9. After the burner tray has ignited, wait approximately 1 minute before reading the dynamic pressures.



10. Use the pressure gauge to read the supply pressure at test nipple (6). Refer to the gas data table ([3.4.3 "Gas data"](#)).

 **Note**

Consult the mains gas supply company if the supply pressure is not correct.

11. Use the pressure gauge to read the burner pressure at nipple (8). Refer to the gas data table ([3.4.3 "Gas data"](#)).

 **Note**

If the burner pressure is not correct and the appliance is fitted with a blank plate or high-low control, you will **not be able to adjust** the pressure. In this case, consult your installation engineer or supplier. If the appliance is indeed fitted with a burner pressure regulator, the pressure can be adjusted ([3.11.2 "Adjusting the pressure"](#)).

3.11.2 Adjusting the pressure

1. Remove the cap (2) from the burner pressure regulator.
2. Depending on the correction required, correct the burner pressure by turning adjustment screw (3):
 - Adjustment screw anticlockwise: burner pressure decreases.
 - Adjustment screw clockwise: burner pressure increases.
3. Cover the opening of the adjusting screw and check the burner pressure against the value given in the gas data table ([3.4.3 "Gas data"](#)).
4. If the pressure reading is not correct, repeat the burner pressure adjustment until the correct pressure is reached.
5. Fit the cap (2) back on the burner pressure regulator.

3.11.3 Finalising

1. Shut off the gas supply.
2. Disconnect the two pressure gauges and retighten the sealing screws in the test nipples.
3. Replace the cover.

 **Note**

Before starting-up the appliance, take time to fill in the warranty card supplied with the appliance. This enables us to guarantee the quality of our systems, and to further enhance our warranty procedure.

Please return this card as soon as possible. Your customer will then receive a warranty certificate with our warranty conditions.





4 Conversion to a different gas category

 **Caution**

The conversion may only be carried out by an authorised installation engineer.

If the appliance must operate on a family of gases (LP gas or natural gas) or other gas category than that for which the appliance has been set at the factory, the appliance will have to be adapted using a special conversion kit.

 **Caution**

You must check the supply pressure and burner pressure once the conversion is complete.

This chapter covers the following:

- [Conversion to different category ADM 40 through 115.](#)
- [Conversion from natural gas to LP gas.](#)

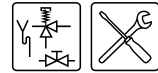

Exchanging orifices

Legend

1. cover plate
2. retaining strips
3. orifice with stamped figures

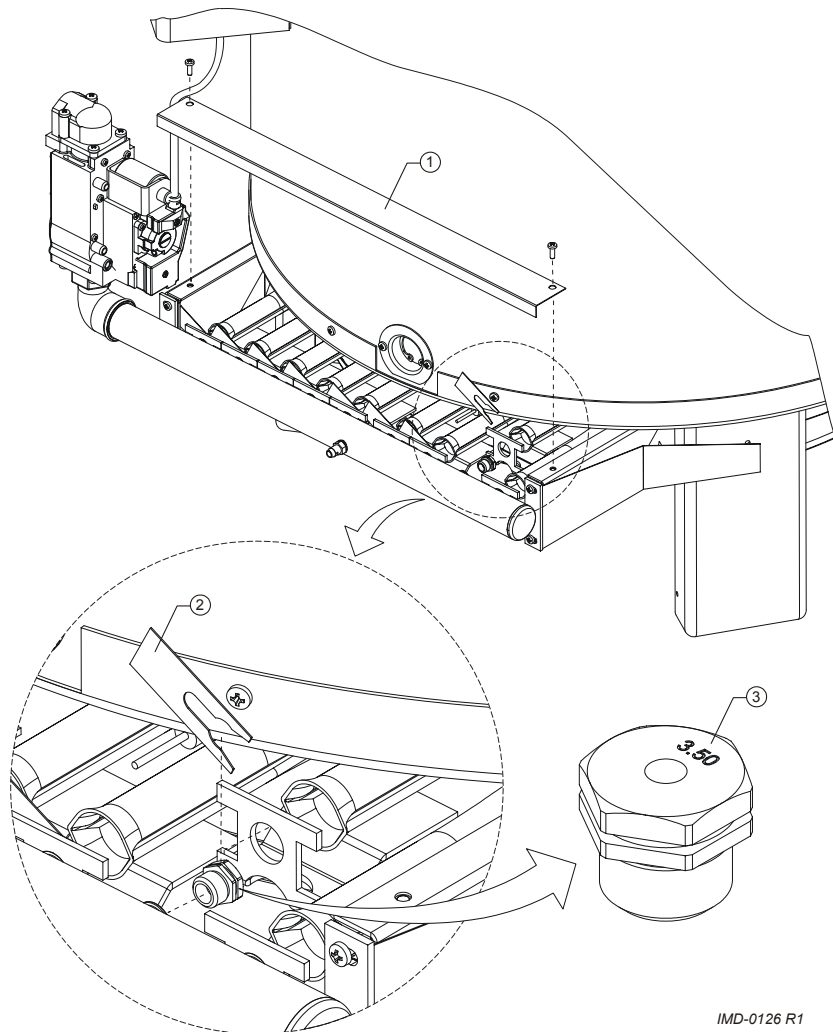

4.1 Conversion to different category ADM 40 through 115

1. Isolate the appliance from the power supply ([10.3 "Isolating the appliance from the mains"](#)).
2. Shut off the gas supply.

Caution
The burner can be hot.

3. Unscrew the cover plate (1) from the burner support.
4. Use a suitable tool to remove the retaining strips (2). Note that the retaining strips have very sharp edges. Withdraw the retaining strips straight upwards.

Note
The radiation shield / condensation tray can be temporarily loosened to simplify disassembly of the burner.

5. Remove the burners one by one from their brackets at the front. To do this, you first move them away from you and then downwards. The orifices will now be accessible
6. Remove the orifices.



7. Select and fit the correct orifices from the conversion kit, based on the gas data table (3.4.3 "Gas data"). The orifice diameter is stamped on the orifice itself, see (3).
8. Re-fit the burners back in their original position.
9. Re-fit the retaining strips.
10. If the radiation shield / condensation tray was loosened, re-fasten it.

Conversion of gas control

Legend

Only applicable numbers are mentioned.

1. burner pressure regulator
4. gas control connector
5. blank plate
6. supply pressure test nipple
7. gas control

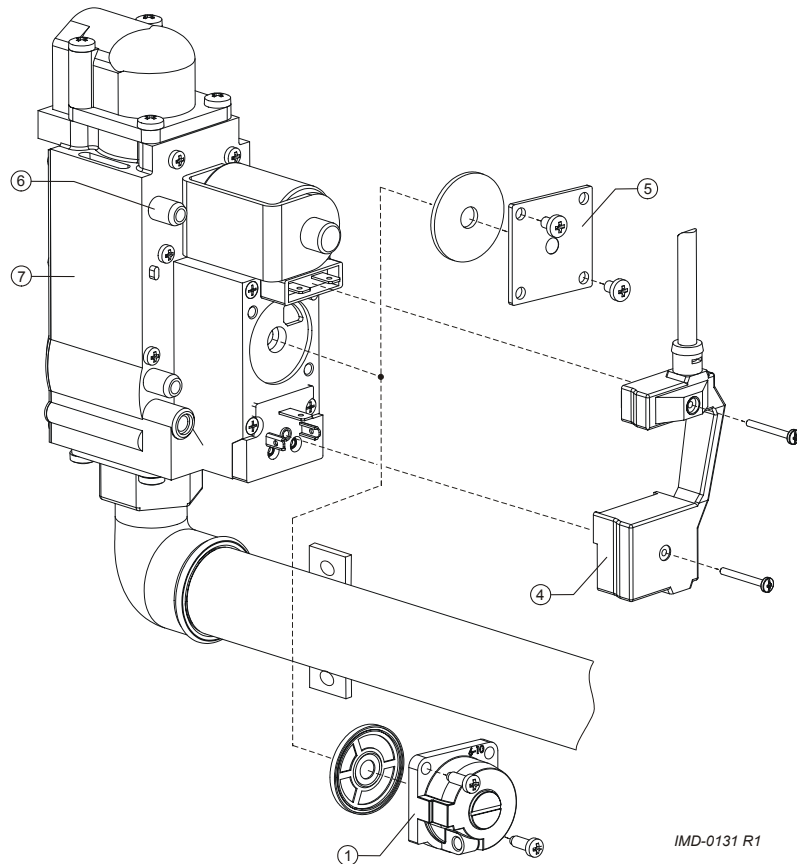

11. Check whether there is a burner pressure regulator (1) attached to the gas control, or simply a blank plate (5).

Note

If the supply pressure for a gas category is the same as the burner pressure (see the gas data table (3.4.3 "Gas data")) then the gas control must be fitted with a blank plate with cork gasket. A burner pressure that deviates in comparison to the supply pressure requires the use of a burner pressure regulator with rubber gasket. Each conversion kit contains all the necessary components.

12. If the blank plate or burner pressure regulator need to be replaced:

- Unscrew the connector (4) of the gas control.
- If necessary, remove the blank plate or burner pressure regulator (5) or burner pressure regulator (1).
- If necessary, fit the blank plate or burner pressure regulator supplied with the conversion kit.
- Fit the connector (4) of the gas control.

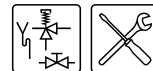

13. Check the supply pressure and burner pressure (3.11 "Checking the supply pressure and burner pressure").
14. Remove the sticker showing the new gas category from the conversion kit, and attach it below the appliance's rating plate. This clearly indicates that the appliance may no longer be run on the gas for which it was originally supplied.
15. Start the appliance (9 "Starting and running").

4.2 Conversion to a different gas category ADM 135

4.2.1 Introduction

This paragraph describes:

- Conversion from LP gas to natural gas
- Conversion from natural gas to LP gas

Conversion of gas control

Legend

Only applicable numbers are mentioned.

1. burner pressure regulator
7. gas control
9. high-low control

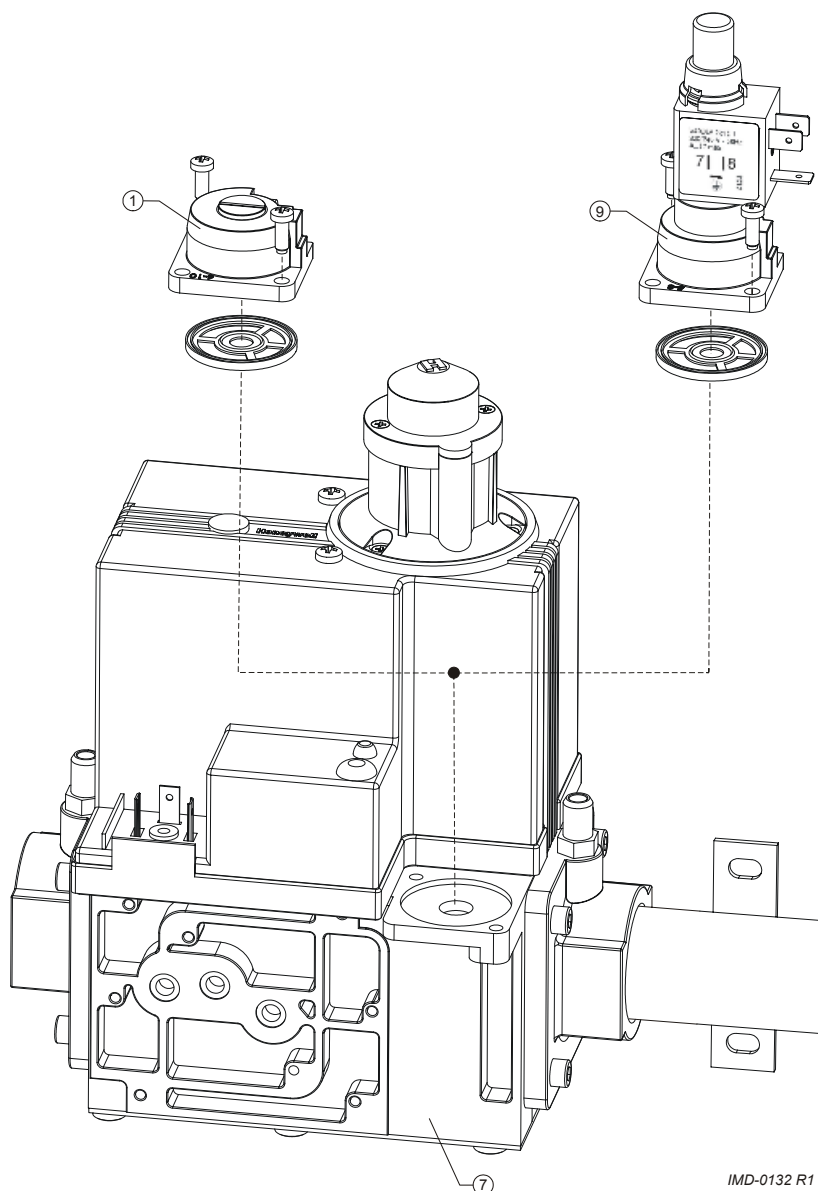

IMD-0132 R1



4.2.2 Conversion from LP gas to natural gas

Installing and removing add-on components

Legend

Only applicable numbers are mentioned.

- 4. timers
- 5. bracket
- 6. 6-contact terminal strip
- 7. strain relief
- 8. 9-contact terminal strip
- 9. metric strain relief
- 10. high-low control lead

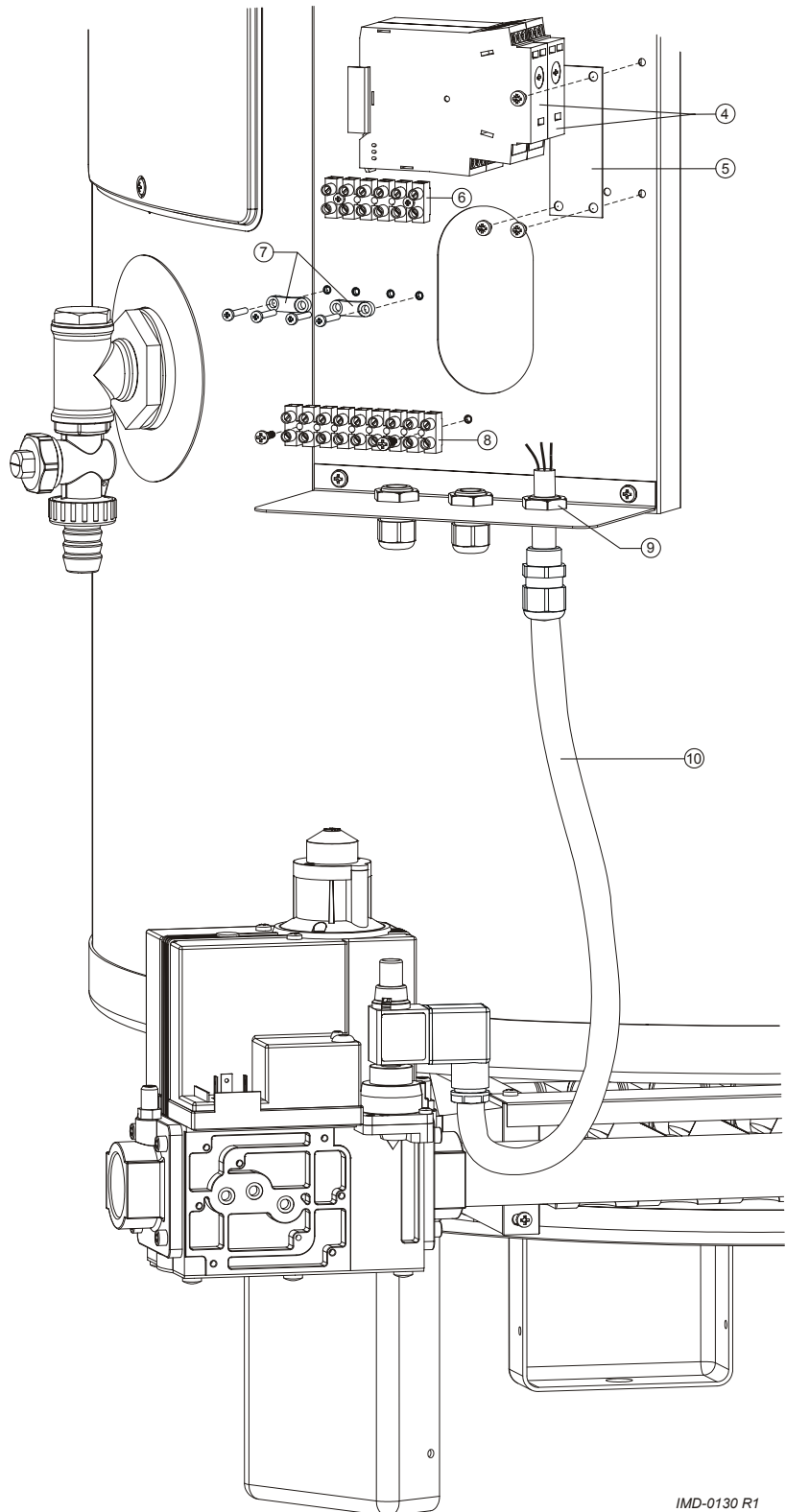

IMD-0130 R1

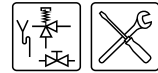

1. Carry out (4.1 "Conversion to different category ADM 40 through 115") steps 1 through 10 .
2. Detach the high-low control (9).
3. Fit the burner pressure regulator (1) including the sealing gasket from the conversion kit. Attach the burner pressure regulator to the gas control using the two small screws supplied (7).
4. Detach the leads between the 6contact terminal strip(6) and the 9contact terminal strip (8). These are the leads for the timers, high-low control, gas control, hot surface igniter and flame probe.
5. Remove the timers (4), bracket (5), wiring harness (not shown) and 9contact terminal strip.
6. Turn the metric strain relief (9) with the high-low control lead (10) to loosen it. Remove this lead.
7. Fit the stop plug from the conversion set in the place of the metric strain relief.
8. Connect the cables of the gas control, the hot surface igniter and flame probe to the 6contact terminal strip as indicated in the electrical diagram (14.2 "Electrical Diagrams ADM").
9. Clamp the gas control cable in one of the supplied strain reliefs (7). Do the same for the leads of the hot surface igniter and flame probe.
10. Check the supply pressure and burner pressure (3.11 "Checking the supply pressure and burner pressure").
11. Remove the sticker showing the new gas category from the conversion kit, and attach it below the appliance's rating plate. This clearly indicates that the appliance may no longer be run on the gas for which it was originally supplied.
12. Start the appliance (9 "Starting and running").

4.2.3 Conversion from natural gas to LP gas

1. Carry out steps 1 through 10 (4.1 "Conversion to different category ADM 40 through 115").
2. Detach the burner pressure regulator (1).
3. Fit the high-low controller (9) including the sealing gasket from the conversion set. Attach the high-low control to the gas control using two small screws.
4. Detach the leads from the gas control, the hot surface igniter and the flame probe to the 6contact connector strip (6) and the strain relief (7).
5. Fit the timers (4) including cable harness plus 9contact terminal strip (6) from the conversion kit to the control column.
6. Remove the stop plug (not shown) from the underside of the control column and replace this with the metric strain relief (9) from the conversion kit.
7. Draw the high-low control lead (10) through the strain relief and tighten the strain relief by turning it until the lead is clamped.
8. Connect the high-low control lead (10) plug to the high-low control (9).
9. Connect the cables from the timers, highlow control, gas control and the hot surface igniter as shown in the electrical diagram (14.2 "Electrical Diagrams ADM").
10. Check the supply pressure and burner pressure (3.11 "Checking the supply pressure and burner pressure").



11. Remove the sticker showing the new gas category from the conversion kit, and attach it below the appliance's rating plate. This clearly indicates that the appliance may no longer be run on the gas for which it was originally supplied.
12. Start the appliance ([9 "Starting and running"](#)).

4

Conversion to a different gas category

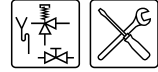

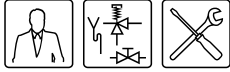

5 Filling

Installation diagram

Legend

Only applicable numbers are mentioned.

- 1. pressure reducing valve (mandatory)
 - 3. T&P valve (mandatory)
 - 4. stop valve (recommended)
 - 5. non-return valve (mandatory)
 - 6. circulation pump (optional)
 - 7. top to bottom circulation pump (optional)
 - 9. drain valve
 - 10. manual gas valve (mandatory)
 - 11. service stop valve (mandatory)
 - 12. temperature gauge (recommended)
 - 14. hot water draw-off points
 - 15. expansion valve (mandatory)
 - 16. expansion vessel (mandatory)
 - 17. 3-way aeration valve (recommended)
 - 18. water tank
 - 19. float valve
- A. cold water supply
 - B. hot water supply
 - C. circulation pipe
 - D. gas supply
 - E. overflow pipe
 - H. overflow pipe

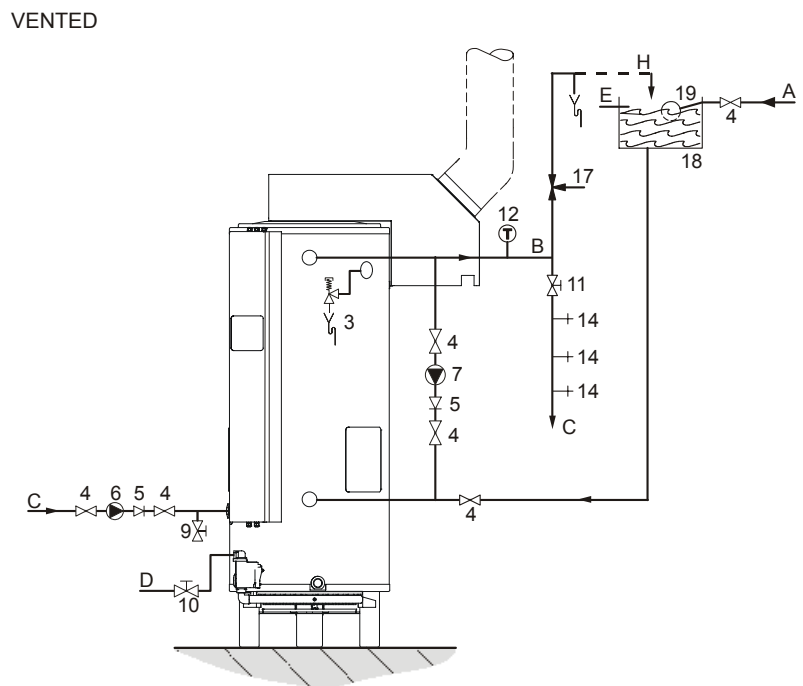
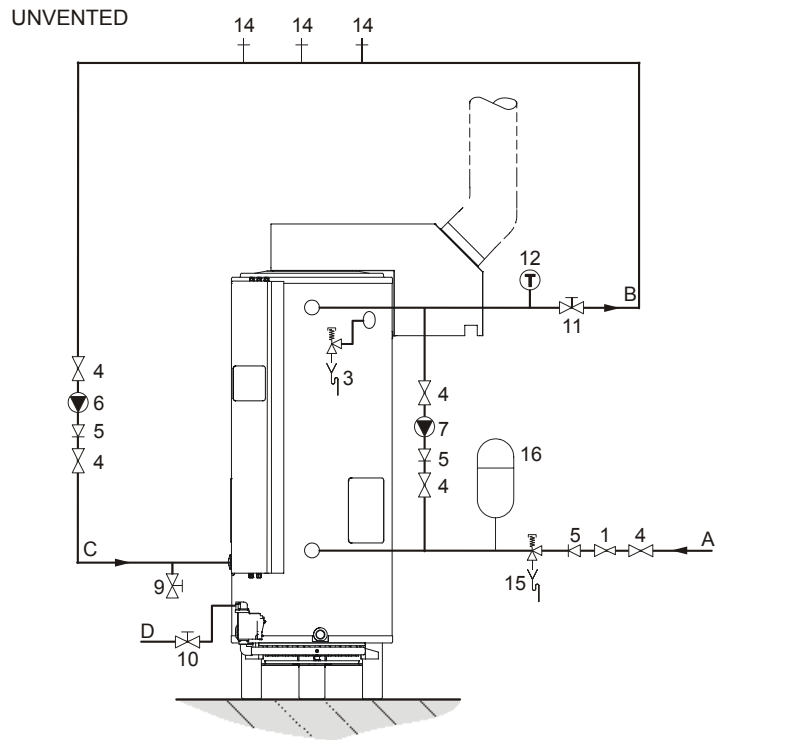

IMD-0466 R0

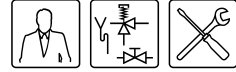

5.1 Filling unvented installations

To fill the appliance, proceed as follows:

1. Open the stop valve (11) in the hot water pipe and, if present, the stop valves (4) for the circulation pump (6).
2. Close the drain valve (9).
3. Open the nearest hot water draw-off point (14).
4. Open the stop valve (4) on the cold water side (A) so that cold water flows into the appliance.
5. Completely fill the appliance. When a full water jet flows from the nearest draw-off point, the appliance is full.
6. Bleed the entire installation of air, for example by opening all draw-off points.
7. The appliance is now under water supply pressure. There should be no water coming out of the expansion valve (15), nor the T&P valve (3). If this does happen, the cause might be:
 - The water supply pressure is greater than the specified 8 bar. Rectify this by fitting a pressure reducing valve (1).
 - The expansion valve in the protected cold supply setup is defective or incorrectly fitted.

5.2 Filling vented installations

To fill the appliance, proceed as follows:

1. Open the stop valve (11) in the hot water pipe and, if present, the stop valves (4) for the circulation pump (6).
2. Close the drain valve (9).
3. Open the nearest hot water draw-off point (14).
4. Open the stop valve (4) on the cold water side (A) so that cold water flows into the appliance.
5. Completely fill the appliance. When a full water jet flows from the nearest draw-off point, the appliance is full.
6. Bleed the entire installation of air, for example by opening all draw-off points.
7. The appliance is now under water supply pressure. There should be no water coming out of the T&P valve (3). If this does happen, the T&P valve might be defective or incorrectly fitted.

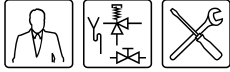

6 Draining

Installation diagram

Legend

Only applicable numbers are mentioned.

- 1. pressure reducing valve (mandatory)
 - 3. T&P valve (mandatory)
 - 4. stop valve (recommended)
 - 5. non-return valve (mandatory)
 - 6. circulation pump (optional)
 - 7. top to bottom circulation pump (optional)
 - 9. drain valve
 - 10. manual gas valve (mandatory)
 - 11. service stop valve (mandatory)
 - 12. temperature gauge (recommended)
 - 14. hot water draw-off points
 - 15. expansion valve (mandatory)
 - 16. expansion vessel (mandatory)
 - 17. 3-way aeration valve (recommended)
 - 18. water tank
 - 19. float valve
- A. cold water supply
 - B. hot water supply
 - C. circulation pipe
 - D. gas supply
 - E. overflow pipe
 - H. overflow pipe

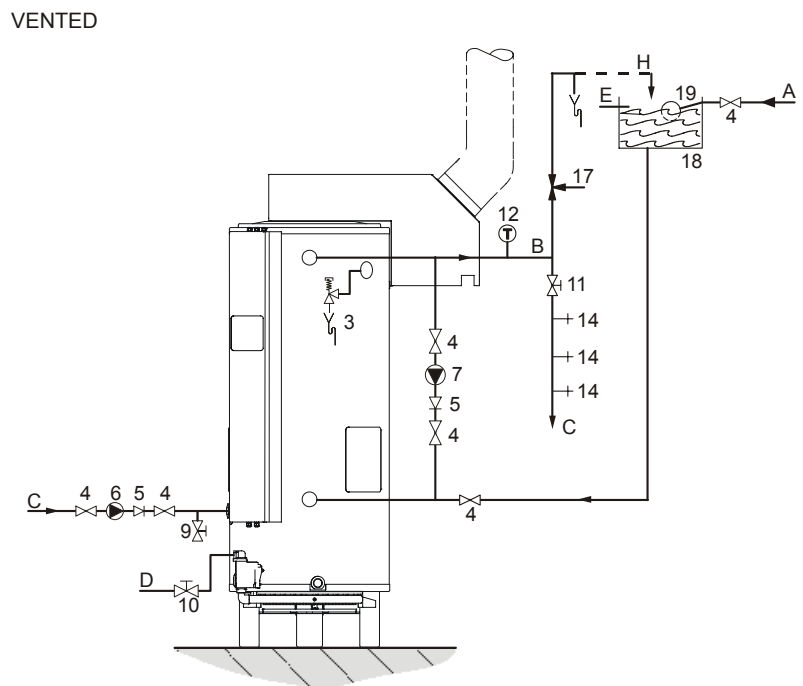
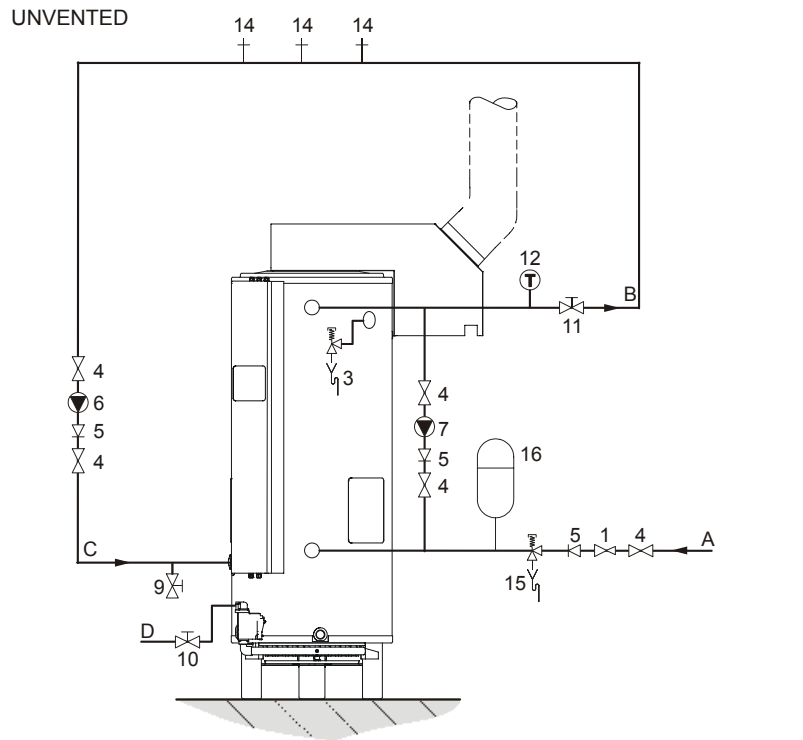

IMD-0466 R0

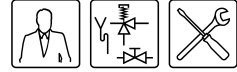

6.1 Draining unvented installations

Some service activities require the appliance to be drained. The procedure is as follows:

1. Shut down the appliance by setting the ON/OFF switch on the control panel to **position 0**.

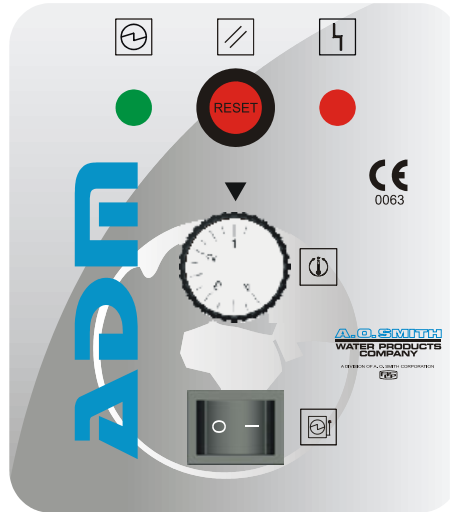

IMD-0460 R0

2. Isolate the water heater from the power supply by putting the isolator between the appliance and the mains power supply to position 0.
3. Shut off the gas supply (10).
4. Close the stop valve (11) in the hot water pipe.
5. Close the supply valve of the cold water supply (A).
6. Open the drain valve (9).
7. Bleed the appliance (or installation) so that it drains completely.

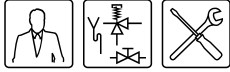

6.2 Draining vented installations

Some service activities require the appliance to be drained. The procedure is as follows:

1. Shut down the appliance by setting the ON/OFF switch on the control panel to **position 0**.

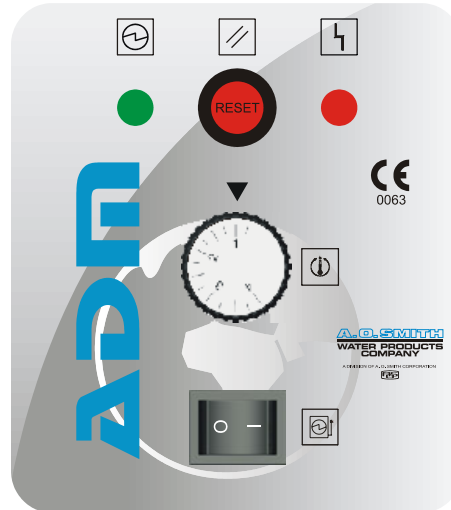

2. Isolate the water heater from the power supply by putting the isolator between the appliance and the mains power supply to position 0.
3. Shut off the gas supply (10).
4. Close the stop valve (11) in the hot water pipe.
5. Close the stop valve (4) between the cold water head tank and the cold water inlet.
6. Open the drain valve (9).
7. Bleed the appliance (or installation) so that it drains completely.

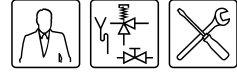



7 The control panel

7.1 Introduction

Topics covered in this chapter, in sequence:

- [Control panel](#)
- [Explanation of icons](#)
- [ON/OFF switch](#)
- [Control thermostat](#)
- [Burner control reset button](#)
- [Flue gas thermostat reset button](#)

7.2 Control panel

This figure shows the control panel.

The control panel

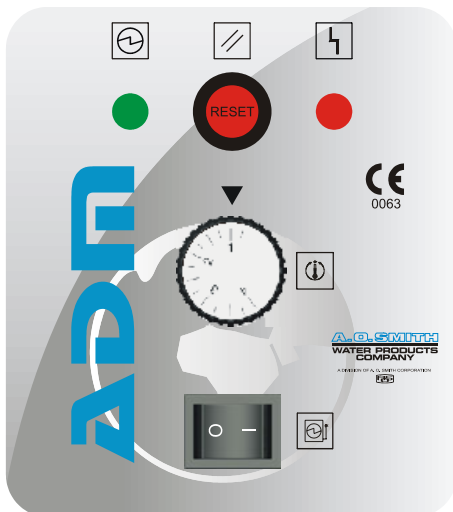

IMD-0460 R0

The control panel comprises:

- an ON/OFF switch
- a reset button
- a control thermostat with rotary knob
- two status LEDs

7.3 Explanation of icons

The table explains the meanings of the icons.

Icons and their meaning

	Name	Explanation
	ON/OFF switch	'ON mode' / 'OFF mode'
	Temperature control	Set water temperature (Tset)
	Reset button	Reset burner control
	Power LED	Power indicator for burner control
	Error LED	Burner control lockout

7.4 ON/OFF switch

The ON/OFF switch sets the appliance in ON mode or OFF mode. In OFF mode the appliance is still electrically live. This ensures that the frost protection is active.

Note

To electrically isolate the appliance, you must use the isolator between the appliance and the mains power supply.

7.5 Control thermostat

Use the rotary knob of the control thermostat to set the desired water temperature between $\pm 40^{\circ}\text{C}$ and $\pm 70^{\circ}\text{C}$. The range is continuous and is labeled 1 through 4. The table shows the temperatures corresponding to the numbers on the knob.

Temperature settings

Position	Temperature
1	$\pm 40^{\circ}\text{C}$
2	$\pm 50^{\circ}\text{C}$
3	$\pm 60^{\circ}\text{C}$
4	$\pm 70^{\circ}\text{C}$

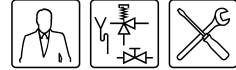

7.6 Burner control reset button

An error can cause the burner control to lock out. When this happens, the red LED on the control panel will illuminate. After eliminating the cause of the error, you can reset the appliance using the reset button.

Note
Before resetting, always eliminate the cause of the error.

The appliance's error conditions ([8.3 "Error conditions"](#)) and how to resolve them are described in the error condition summary ([11 "Troubleshooting"](#)).

7.7 Flue gas thermostat reset button

A malfunction in the flue gas discharge, e.g. a blockage in the chimney, can lead to the flue gas thermostat locking out. This state is evident when the push button on the flue gas thermostat has been activated (refer to the figure). Once the cause has been removed, and the sensor has cooled down sufficiently, press this push button to reset (if the sensor is not sufficiently cooled down, the flue gas thermostat will immediately lock out again). The appliance will then automatically start up again, if there is a demand. If this is not the case, please consult the error condition summary ([11 "Troubleshooting"](#)).

Note
The draught diverter may be hot.

Figure: Flue gas thermostat reset button

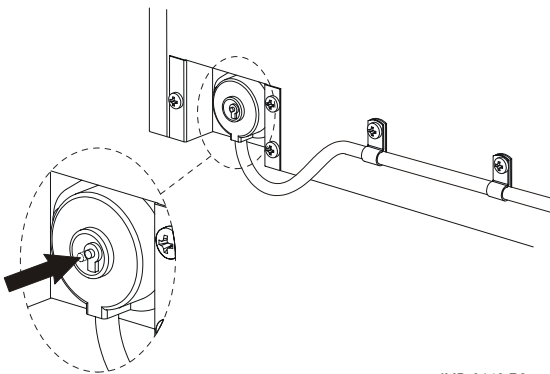

IMD-0140 R2

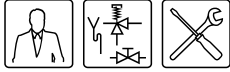

8 Status of the appliance

8.1 Introduction

Topics covered in this chapter:

- [Operating modes](#);
- [Error conditions](#);

8.2 Operating modes

When running, the appliance has three basic operating modes, namely:

- **ELECTRICALLY ISOLATED**

In this mode, the appliance is off and no components are live. The isolator (switch between the appliance and the mains power supply) is off. On the control panel:

- the ON/OFF switch is at position 0;
- the green light is dimmed.

- **OFF**

In this mode, the frost protection is activated. The isolator is at position I. On the control panel:

- the ON/OFF switch is at position 0;
- the green light is lit.

- **ON**

In this mode, the appliance continuously responds to the heat demand. On the control panel:

- the ON/OFF switch is at position I;
- the water temperature can be set using the rotary knob of the control thermostat ([7.5 "Control thermostat"](#));
- the green light is lit.

8.3 Error conditions

If the water heater goes into an "error" condition, you will be unable to draw hot water. The frost protection will also be out of operation. These error conditions are divided into three groups:

- **Lockout error from the flue gas thermostat**

The safety (pushbutton) on the flue gas thermostat in the draught diverter has been activated. After removing the cause, the pushbutton ([7.6 "Burner control reset button"](#)) must be pressed to restart the appliance.

- **Lockout error from the flue gas thermostat**

When this happens, the red LED on the control panel will be illuminated. The burner control is locked out.

After eliminating the cause, the appliance must be returned to service by pressing the reset button ([7.6 "Burner control reset button"](#)).

- **Blocking errors**

You can recognise this condition from the fact that the appliance does not start running even though the water temperature is lower than the setting that you have defined using the control thermostat ([7.5 "Control thermostat"](#)).

These errors disappear automatically once the cause of the error has been removed, after which the appliance resumes operation by itself.

The cause of the error cannot be seen on the control panel. For a detailed overview of error conditions, please refer to the error tables ([11 "Troubleshooting"](#)).

If, as end-user, you find the appliance in an error condition, you may attempt to restart the appliance by pressing the reset button once. However, if the error returns or occurs several times in a short time, you must contact your service and maintenance engineer.

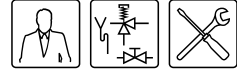

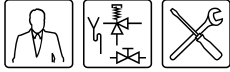

9 Starting and running

9.1 Introduction

Topics covered in this chapter:

- [Starting the appliance](#);
- [The appliance's heating cycle](#).

9.2 Starting the appliance

Start the appliance as follows:

1. Fill the appliance ([5 "Filling"](#)).
2. Open ([3.5 "Installation diagram"](#)) the manual gas valve.
3. Switch on the power to the appliance using the isolator between the appliance and the power supply.
4. Put the appliance in ON mode by setting the ON/OFF switch on the control panel to **position I**.
5. Using the control thermostat ([7.5 "Control thermostat"](#)), set the desired water temperature.

If there is a heat demand, the appliance will run through the heating cycle ([9.3 "The appliance's heating cycle"](#)).

9.3 The appliance's heating cycle

The appliance's heating cycle is activated as soon as the measured water temperature (T_{water}) falls below the threshold value (T_{set}). This threshold value depends on the currently selected appliance operating mode. For example, if the appliance is in OFF mode (frost protection), then this value is 20°C. If the appliance is in ON mode, for example, then this threshold value can be selected, e.g. position 3 ($\pm 60^\circ\text{C}$).

The heating cycle runs successively through the following states:

1. HEAT DEMAND;
2. WAIT;
3. PRE-GLOW;
4. IGNITION;
5. RUNNING;
6. WAIT.

The entire cycle is explained in the example below.

Note

The cycle has the same steps when frost protection is activated.

1. The control thermostat sensor measures the temperature. The water temperature falls below the set temperature of (for example) 60°C, causing the control thermostat to close. The burner control now detects a demand and starts the heating cycle.
2. Following demand, the wait period starts. This wait ensures that the ignition is safe. The wait period lasts approximately 15 seconds.
3. Once the wait period has elapsed (there is audible 'clicking' of the relay in the burner control), the PRE-GLOW starts.
4. After about 12 seconds (pre)glowing, the gas control opens and ignition takes place.
5. After ignition, the flame is detected and the appliance will be running. This means that actual heating has started.
6. When the water reaches the set temperature, the demand ceases. The gas control closes and the burner tray is extinguished. A new wait period of about 10 seconds starts.
7. At the end of this wait, the appliance enters the idle state, and waits until the water temperature once more falls below the set temperature.

With any subsequent heat demand, the heating cycle will resume from step 1.

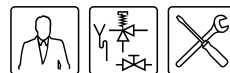

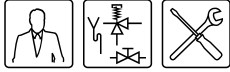

10 Shutting down

10.1 Introduction

Topics covered in this chapter:

- [Shutting down the appliance for a brief period \(OFF mode\)](#);
- [Isolating the appliance from the mains](#);
- [Shutting the appliance down for a long period](#).

10.2 Shutting down the appliance for a brief period (OFF mode)

To shut the appliance down for a brief period, you must activate frost protection using the appliance's heating cycle ([2.3 "The appliance's heating cycle"](#)).

By using the frost protection, you can prevent water freezing in the appliance. Frost protection is activated by setting the ON/OFF switch on the control panel to position 0.

10.3 Isolating the appliance from the mains

The appliance should only be isolated from mains power in the correct way. The correct procedure is as follows:

1. Shut down the appliance by setting the ON/OFF switch to position 0.
2. Isolate the water heater from the power supply by putting the isolator between the appliance and the mains power supply to position 0.

10.4 Shutting the appliance down for a long period

To shut the appliance down for a longer period, you must drain the appliance ([6 "Draining"](#)).

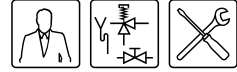



11 Troubleshooting

11.1 Introduction

This chapter deals with the following problems with the appliance:

- Gas smell.
- Water leakage.
- Explosive ignition.
- Poor flame profile.
- No hot water.
- Insufficient hot water.

11.2 Error conditions

If the water heater goes into an "error" condition, you will be unable to draw hot water. The frost protection will also be out of operation. These error conditions are divided into three groups:

- **Lockout error from the flue gas thermostat**

The safety (pushbutton) on the flue gas thermostat in the draught diverter has been activated. After removing the cause, the pushbutton ([7.6 "Burner control reset button"](#)) must be pressed to restart the appliance.

- **Lockout error from the flue gas thermostat**

When this happens, the red LED on the control panel will be illuminated. The burner control is locked out.

After eliminating the cause, the appliance must be returned to service by pressing the reset button ([7.6 "Burner control reset button"](#)).

- **Blocking errors**

You can recognise this condition from the fact that the appliance does not start running even though the water temperature is lower than the setting that you have defined using the control thermostat ([7.5 "Control thermostat"](#)).

These errors disappear automatically once the cause of the error has been removed, after which the appliance resumes operation by itself.

The following pages provide troubleshooting tables for each type of error.

 **Note**

Footnotes referred to from within any table are shown at the bottom of the last page of that table.

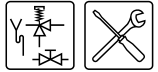

11.3 Troubleshooting table for general errors

Warning
Maintenance may only be performed by a qualified service and maintenance engineer.

General faults and failures

Symptom	Cause	Precautions	Comment
Gas smell	Gas leak	Warning Close the main gas valve immediately.	Note Contact your installation engineer or local gas company immediately.
		Warning Do not operate any switches.	
		Warning No naked flames.	
		Warning Ventilate the boiler room.	
Water leakage	Leakage from a water connection (threaded)	Tighten the threaded connection	If the leak persists, consult your installation engineer
	Leakage from another nearby water appliance or pipe segment	Trace the leak	
	Leakage from the appliance's tank	Consult the supplier and/or manufacturer	
	Condensation	Before drawing (too much) tap water, wait until the water in the boiler has reached the set temperature.	
Explosive ignition Poor flame profile	Incorrect supply pressure and/or burner pressure	Set the correct supply pressure and/or burner pressure. (3.11 " Checking the supply pressure and burner pressure ")	If ignition is not improved, consult your installation engineer.
	Contaminated burner	Clean the burner(s) (12.4.2 " Clean the burner(s) ")	
	Contaminated orifice	Clean the orifice(s) (12.4.3 " Clean the orifice(s) ")	
	Inadequate air supply	Improve the air supply by providing better ventilation in the boiler room.	

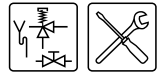

11.4 ADM Troubleshooting table - no hot water

Warning
Maintenance may only be performed by a qualified service and maintenance engineer.

No hot water

Symptom	Cause	Precautions	Comment
Green LED OFF and Red LED ON	No supply voltage present	<ol style="list-style-type: none"> 1. Check if the isolator is ON. 2. Check whether there is power to the isolator 3. Check whether there is power to the electrical connector block 4. Check whether there is power to the burner control 5. Check fuse in the burner control <p>The measured voltage must be 230 VAC (-15%, +10%).</p>	See the ADM electrical diagram (14 "Appendices") If the error cannot be rectified, contact your installation engineer
Green LED ON and Red LED OFF	Blockage in the flue gas discharge (the flue gas thermostat has cut out)	<ol style="list-style-type: none"> 1. Trace the blockage 2. Remove the blockage 3. Reset flue gas thermostat (7.7 "Flue gas thermostat reset button"). 	When a demand is detected, the appliance will restart

Symptom	Cause	Precautions	Comment
Green LED ON and Red LED ON	There are three possible causes for this error. In order to determine the cause, you must cause the error to appear again:	<ol style="list-style-type: none"> 1. Reset the appliance by pressing the reset button 1x 2. If nothing happens, then the reset button has been pressed too often (maximum 5 times in a single heating cycle). Disconnect the appliance from the mains and then restart it. See isolating the appliance from the mains and steps 3 through 5 of Starting the appliance. 3. Decide which type of cause (a) or (b) describes the situation. (see tables below) 	If the error cannot be resolved or is persistent, contact your installation engineer

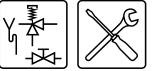

Symptom	Cause	Precautions	Comment
	(a) three unsuccessful start attempts in a row	<ol style="list-style-type: none"> 1. No gas: <ul style="list-style-type: none"> - Check that the gas valve is open - Check whether the gas control is opening (clicking of the gas control) - Check the leads of the gas control 2. No ignition: <ul style="list-style-type: none"> - Check whether the hot surface igniter lights up - Check the electrical supply to the hot surface igniter. - Check the leads of the glow igniter 3. No flame detection: <ul style="list-style-type: none"> - Check that the Phase (L) and Neutral (N) are correctly connected (from the mains) to the appliance - Check whether the flame probe is defective - Check that the flame probe leads are properly connected 	If the error cannot be resolved or is persistent, contact your installation engineer

Symptom	Cause	Precautions	Comment
	(b) The safety thermostat has cut out	<ol style="list-style-type: none"> 1. The safety thermostat has cut out correctly: <ul style="list-style-type: none"> - Reset the appliance - Check whether the control thermostat is working - Check whether the high-limit thermostat is working - Check that the circulation pump (if present) is working 2. The safety thermostat has cut out without apparent reason: <ul style="list-style-type: none"> - Check whether the thermostat is defective - Check whether the sensor of the thermostat is defective 	If the error cannot be resolved or is persistent, contact your installation engineer

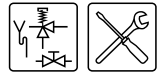

11.5 Troubleshooting table - 'insufficient hot water'

Warning
Maintenance may only be performed by a qualified service and maintenance engineer.

Insufficient hot water

Symptom	Cause	Precautions	Comment
Insufficient hot water	Water temperature setting (T_{set}) is too low	Set the control thermostat (7.5 "Control thermostat") to a higher value	
	Hot water supply is used up	<ol style="list-style-type: none">1. Reduce hot water consumption and give the appliance time to heat up.2. If this error persists, check whether the high-limit thermostat is switching. If this is the case, check that the circulation and/or top to bottom circulation pump are working.	If the error has not been rectified, and no other cause can be found, isolate the appliance from the mains (10.3 "Isolating the appliance from the mains"), shut off the manual gas valve and alert your installation engineer.

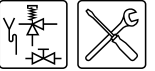



12 Performing maintenance

12.1 Introduction

Caution

Maintenance may only be carried out by an approved service and maintenance engineer.

At each service, the appliance undergoes maintenance on both the water side and the gas side. The maintenance must be carried out in the following order.

1. [Water-side maintenance](#)
2. [Water-side maintenance](#)
3. [Gas-side maintenance](#)
4. [Finalising maintenance](#)

Note

Before ordering spare parts, it is important to write down the appliance type and model, and the full serial number of the appliance. These details can be found on the rating plate. Only by ordering with this information can you be sure to receive the correct spare parts.

12.2 Preparation for maintenance

To test whether all components are still working properly, complete the following steps:

1. Set the ON/OFF switch on the control panel to **position 0**.
2. Set the control thermostat to the highest value (note the original setting) and set the ON/OFF switch back again to **position I**.
3. If there is no heat demand, draw off some water to create a heat demand.
4. Check whether the heating cycle ([9.3 "The appliance's heating cycle"](#)) runs correctly.
5. Set the control thermostat back to the original setting and set the ON/OFF switch back again to **position I**.
6. Check the supply and burner pressure ([3.11 "Checking the supply pressure and burner pressure"](#)), and adjust them if necessary.
7. Check that all components of the chimney flue system are properly attached.
8. Test the operation of the overflow valve of the protected cold supply set-up. The water should spurt out.
9. Test the overflow operation of the T&P valve. The water should spurt out.
10. Test the overflow operation of the T&P valve. The water should spurt out with a strong jet.
11. Check the drainpipes from the discharge points of all valves and remove any scale deposits that may be present.
12. Drain the appliance ([6 "Draining"](#)).



12.3 Water-side maintenance

12.3.1 Introduction

The following steps must be carried out on the water side:

1. [Checking the anodes.](#)
2. [Descaling and cleaning the tank.](#)

12.3.2 Checking the anodes

Timely replacement of the anodes extends the service life of the appliance. The appliance's anodes must be replaced as soon as they are 60% or more consumed (take this into consideration when determining the maintenance frequency).



Warning

The draught diverter and the cover may be hot.

1. Remove the protective cover from the control column by unscrewing the 4 screws in the cover.
2. Detach the wiring for the flue gas thermostat from the connector block and remove the cable from the strain relief.
3. Remove the cable clamps holding the flue gas thermostat cable.
4. Disconnect the draught diverter from the flue gas discharge.
5. Undo the screws on the draught diverter.
6. Remove the draught diverter from the appliance.
7. Undo the screws of the lid in the top side of the appliance.
8. Remove the lid from the appliance.
9. Remove the sealing ring from the appliance.
10. Loosen the anodes using suitable tools.
11. Check the anodes, and replace them if necessary.
12. Now also check the flue baffles ([12.4.4 "Checking the flue baffles"](#)). If necessary, replace them.
13. Place a new sealing ring on the rim of the tank and re-fit the lid.
14. Fit the draught diverter ([3.9.2 "Fitting the draught diverter"](#)).
15. Feed the cable of the flue gas thermostat through the strain relief and attach the wiring to the connector block ([14.2 "Electrical Diagrams ADM"](#)).
16. Refit the cable clamps to the appliance and draught diverter.
17. Re-fit the protective cover.

12.3.3 Descaling and cleaning the tank

Scale and lime buildup prevent effective conduction of the heat to the water. Periodic cleaning and descaling prevents buildup of these deposits. This increases the service life of the appliance, and also improves the heating process.

Take the rate of scale formation into account when deciding on maintenance frequency. Scale formation depends on the local water composition, the water consumption and the water temperature setting. A water temperature setting of maximum 60°C is recommended for prevention of excessive scale buildup.

To ensure the perfectly watertight sealing of a cleaning opening, the gasket (6), O-ring (7), sealing rings (4), bolts (3) and possibly the lid (5) should be replaced with new components after opening (see the figure). A special set is obtainable from the supplier/manufacturer.



To simplify the task of descaling and cleaning the tank, the appliance is equipped with two cleaning openings.

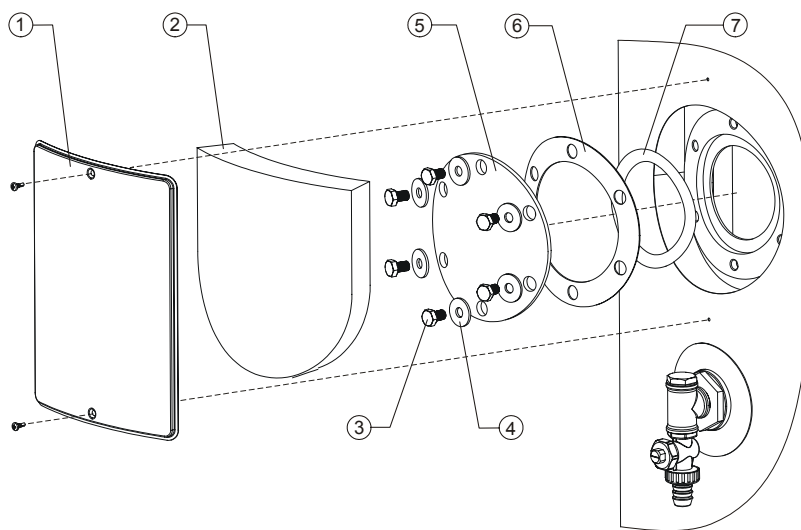

IMD-0235 R2

1. Remove the cover plate (1) on the outer jacket (see the figure).
2. Carefully remove the insulation layer (2) and set it to one side. This will be needed again later.
3. Undo the bolts.
4. Remove the lid, the gasket and the O-ring.
5. Inspect the tank and remove the loose scale deposits and contamination.
6. If the scale cannot be removed by hand, descale the appliance with a descaling agent. Contact the supplier/manufacturer for advice on what descaling agent to use.

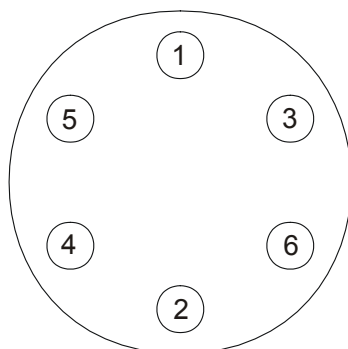

IMD-0282 R1

7. Close the cleaning opening. To avoid damage to the tank, tighten the bolts that fasten the lid with a torque no greater than 50 Nm. Use suitable tools for this. For the best possible watertight seal of the cleaning opening, the bolts in the lid should be torqued down in the sequence shown in the figure.

12.4 Gas-side maintenance



12.4.1 Introduction

The following steps must be carried out on the gas side:

1. [Clean the burner\(s\)](#).
2. [Clean the orifice\(s\)](#).
3. [Checking the flue baffles](#).

12.4.2 Clean the burner(s)

1. Detach the burner(s)
2. Remove all contamination present on the burner(s).
3. Fit the burner(s)

12.4.3 Clean the orifice(s)

1. Detach the orifice(s)
2. Remove all contamination present in the orifice(s).
3. Fit the orifice(s)

12.4.4 Checking the flue baffles



Warning

The flue baffles can be hot.

1. Remove the flue baffles from the appliance.
2. Check the flue baffles for the presence of corrosion, removing this if necessary.
3. Check the flue baffles for wear, and replace the flue baffles if necessary.
4. Place a new sealing ring on the rim of the tank and re-fit the lid.
5. Fit the draught diverter ([3.9.2 "Fitting the draught diverter"](#)).
6. Feed the cable of the flue gas thermostat through the strain relief and attach the wiring to the connector block ([14.2 "Electrical Diagrams ADM"](#)).
7. Refit the cable clamps to the appliance and draught diverter.
8. Re-fit the protective cover.

12.5 Finalising maintenance

To finalise the maintenance, carry out the following steps:

1. Fill the appliance ([5 "Filling"](#)).
2. Start the appliance ([9 "Starting and running"](#)).

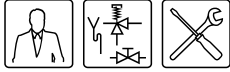

13 Warranty (certificate)

To register your warranty, you should complete and return the enclosed warranty card after which a warranty certificate will be sent to you. This certificate gives the owner of a appliance supplied by A.O. Smith Water Products Company B.V. of Veldhoven, The Netherlands (hereinafter "A.O. Smith") the right to the warranty set out below, defining the commitments of A.O. Smith to the owner.

13.1 General warranty

If within one year of the original installation date of a water heater supplied by A.O. Smith, following verification, and at the sole discretion of A.O. Smith, a section or part (with exclusion of the tank) proves to be defective or fails to function correctly due to manufacturing and/or material defects, then A.O. Smith shall repair or replace this section or part.

13.2 Tank warranty

If within 3 years of the original installation date of a water heater supplied by A.O. Smith, following inspection, and at the sole discretion of A.O. Smith, the glass-lined steel tank proves to be leaking due to rust or corrosion occurring on the water side, then A.O. Smith shall offer to replace the defective water heater with an entirely new water heater of equivalent size and quality. The warranty period given on the replacement water heater shall be equal to the remaining warranty period of the original water heater that was supplied. Notwithstanding that stated earlier in this article, in the event that unfiltered or softened water is used, or allowed to stand in the water heater, the warranty shall be reduced to one year from the original installation date.

13.3 Conditions for Installation and use

The warranty set out in article 1 and 2 will apply solely under the following conditions:

- a. The water heater is installed under strict adherence to A.O. Smith installation instructions for the specific model, and the relevant government and local authority installation and building codes, rules and regulations in force at the time of installation.
- b. The water heater remains installed at the original site of installation.
- c. The appliance is exclusively used with drinking water, which at all times can freely circulate (a separately installed heat exchanger is mandatory for heating salt water or corrosive water).
- d. The tank is safeguarded against harmful scaling and lime buildup by means of periodic maintenance.
- e. The water temperatures in the heater do not exceed the maximum setting of the thermostats, which form a part of the water heater.
- f. The water pressure and/or heat load do not exceed the maximum values stated on the water heater rating plate.
- g. The water heater is installed in a non-corrosive atmosphere or environment.
- h. The water heater is connected to a protected cold supply arrangement, which is: approved by the relevant authority; with sufficient capacity for this purpose; supplying a pressure no greater than the working pressure stated on the water heater; and where applicable by a likewise approved temperature and pressure relief valve, fitted in accordance with installation instructions of A.O. Smith applying to the specific model of water heater, and further in compliance with the government and local authority installation and building codes, rules and regulations.

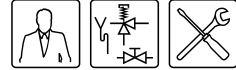

- i. The appliance is at all times fitted with cathodic protection. If sacrificial anodes are used for this, these must be replaced and renewed when, and as soon as, they are 60% or more consumed. When electric anodes are used, it is important to ensure that they continue to work properly.

13.4 Exclusions

The warranty set out in articles 1 and 2 will not apply in the event of:

- a. damage to the water heater caused by an external factor;
- b. misuse, neglect (including frost damage), modification, incorrect and/or unauthorised use of the water heater and any attempt to repair leaks;
- c. contaminants or other substances having been allowed to enter the tank;
- d. the conductivity of the water being less than 125 $\mu\text{S}/\text{cm}$ and/or the hardness (alkaline-earth ions) of the water being less than 1.00 mmol/litre ([3.3.3 "Water composition"](#));
- e. unfiltered, recirculated water flowing through or being stored in the water heater;
- f. any attempts at repair to a defective water heater other than by an approved service engineer.

13.5 Scope of the warranty

The obligations of A.O. Smith pursuant to the specified warranty do not extend beyond free delivery from the Veldhoven warehouse of the replacement sections, parts or water heater respectively. Shipping, labour, installation and any other costs associated with the replacement will not be accepted by A.O. Smith.

13.6 Claims

A claim on grounds of the specified warranty must be submitted to the dealer from whom the water heater was purchased, or to another authorised dealer for A.O. Smith Water Products Company products. Inspection of the water heater as referred to in articles 1 and 2 shall take place in one of the laboratories of A.O. Smith Water Products Company.

13.7 Obligations of A.O. Smith

A.O. Smith grants no other warranty or guarantee over its water heaters nor the (sections or parts of) water heaters supplied for replacement, other than the warranty expressly set out in this Certificate.

Under the terms of the supplied warranty, A.O. Smith is not liable for damage to persons or property caused by (sections or parts, or the glass-lined steel tank of) a (replacement) water heater that it has supplied.



14 Appendices

14.1 Introduction

This section gives the electrical diagrams for:

- [Electrical diagram for ADM 40 to 135 natural gas and 40 to 115 LPG](#)
- [Electrical diagram 135 - LP gas](#)



14.2 Electrical Diagrams ADM

14.2.1 Electrical diagram for ADM 40 to 135 natural gas and 40 to 115 LPG

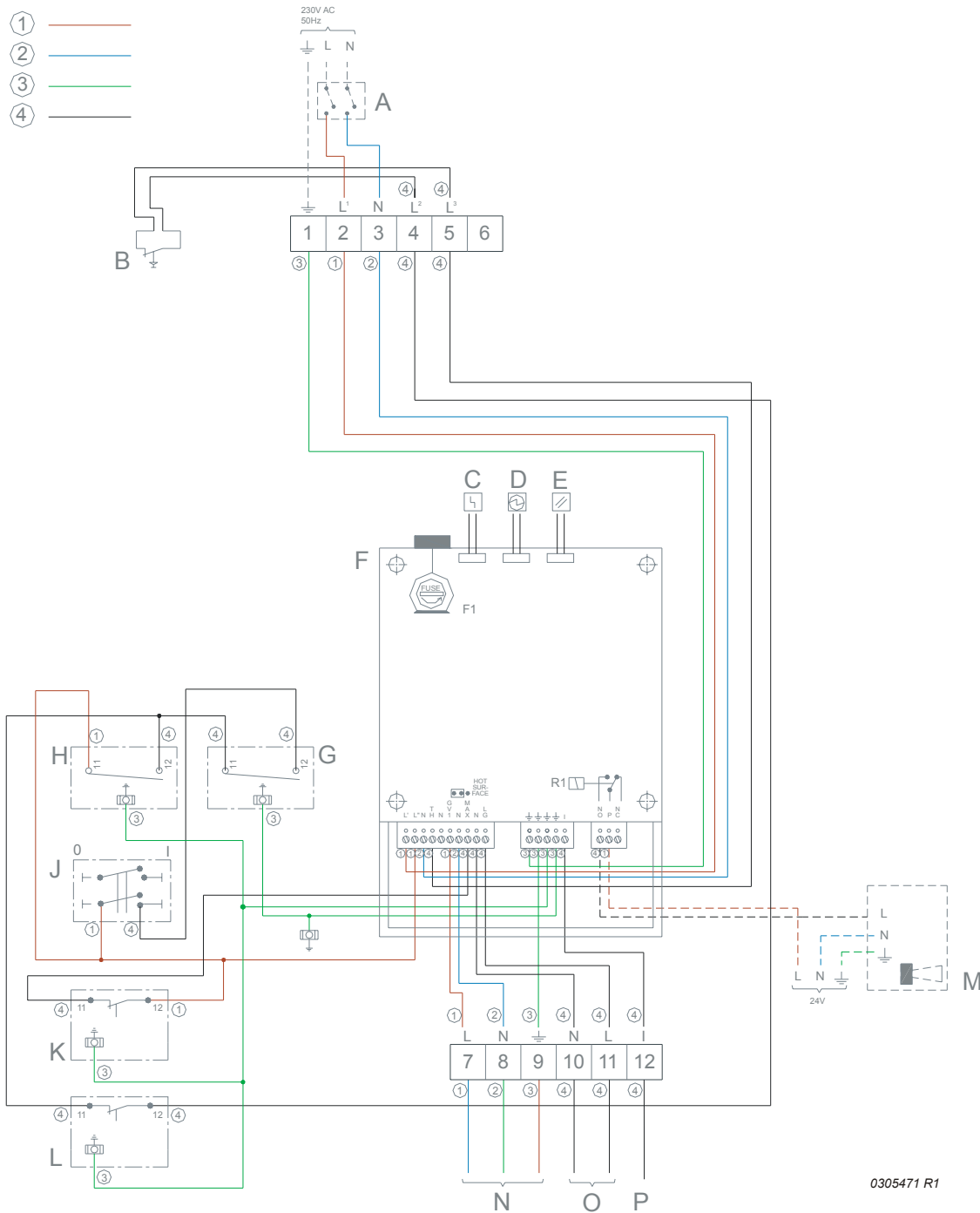

1 = brown, 2 = blue, 3 = yellow/green, 4 = black, 5 = white (flat cable)



TERMINAL STRIP CONNECTIONS:

⏚	Earth
N	Neutral
L ¹	Phase input of controller
L ²	Phase input of flue gas thermostat
L ³	Phase output of flue gas thermostat

COMPONENTS:

A	Two-pole isolator switch
B	Flue gas thermostat
C	"Error" signalling
D	"Operational" signalling
E	RESET button
F	Burner control
G	Control thermostat
H	Frost thermostat
J	Controller 0/I switch
K	Safety thermostat
L	High-limit thermostat
M	Extra error signal connection
N	Gas control
O	Hot surface igniter
P	Flame probe

CONTROLLER CONNECTIONS:

N1	Neutral
⏚	Earth
L'	Phase input of controller
L''	Phase output to safety circuit and thermostat circuit
TH	Phase input of thermostat circuit
GV1	Phase output to gas control
MAX	Phase input to safety thermostat
LG	Phase output to hot surface igniter
I	Detection of ionisation signal
NO	Normally open port of the extra error sensor
P	Phase input of extra error sensor
NC	Normally closed port of the extra error sensor
F1	Fuse



14.2.2 Electrical diagram 135 - LP gas

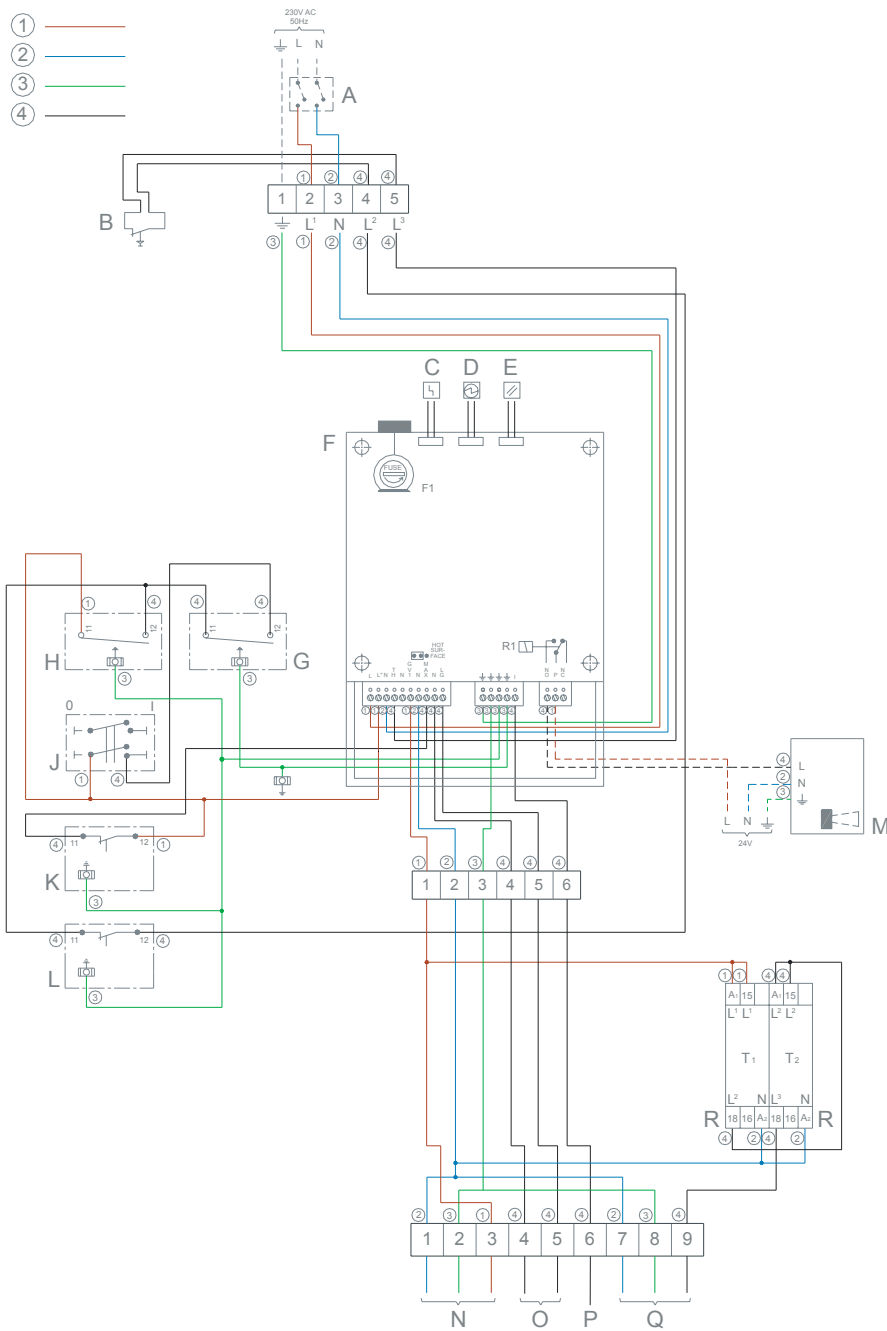

0304481 R1

1 = brown, 2 = blue, 3 = yellow/green, 4 = black, 5 = white (flat cable)



TERMINAL STRIP CONNECTIONS:

⏚	Earth
N	Neutral
L ¹	Phase input of controller
L ²	Phase input of flue gas thermostat
L ³	Phase output of flue gas thermostat

COMPONENTS:

A	Two-pole isolator switch
B	Flue gas thermostat
C	"Error" signalling
D	"Operational" signalling
E	RESET button
F	Burner control
G	Control thermostat
H	Frost thermostat
J	Controller 0/I switch
K	Safety thermostat
L	High-limit thermostat
M	Extra error signal connection
N	Gas control
O	Hot surface igniter
P	Flame probe
Q	High-low control
R	Timer

CONTROLLER CONNECTIONS:

N1	Neutral
⏚	Earth
L'	Phase input of controller
L''	Phase output to safety circuit and thermostat circuit
TH	Phase input of thermostat circuit
GV1	Phase output to gas control
MAX	Phase input to safety thermostat
LG	Phase output to hot surface igniter
I	Detection of ionisation signal
NO	Normally open port of the extra error sensor
P	Phase input of extra error sensor
NC	Normally closed port of the extra error sensor
F1	Fuse

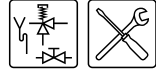

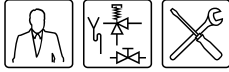

Index

- A**
 - ambient temperature 15
- B**
 - burner pressure 28
- C**
 - claims 66
 - connect
 - circulation piping 23, 24
 - cold water side 22, 23
 - electrical 26, 28
 - gas 24
 - hot water side 23
 - shut pipe 22, 23
 - connecting circulation pipe 23, 24
 - connecting cold water side 22, 23
 - connecting hot water side 23
 - control thermostat 47
 - conversion to a different gas category 33
- D**
 - document contents 9
 - draining 43
- E**
 - electrical connection 26
 - environmental conditions 15
- F**
 - filling 41
 - flame probe 13
 - forms of notation 8
- G**
 - gas category, conversion to different 33
 - gas connection 24
 - general specifications 3
- H**
 - heating cycle 12
 - humidity 15
- I**
 - icons
 - explanation 47
 - installation engineer 8, 9
 - isolator 28
- L**
 - liability 3
- M**
 - mains power 28
 - maintenance
 - burner 64
 - finalising 64
 - gas-side 63
 - orifice 64
 - perform 61
 - preparation 61
 - water-side 62
- O**
 - operating modes 49
- P**
 - packaging 15
 - protection 12
- R**
 - running 51
- S**
 - scale 62
 - service check 8
 - service engineer 8
 - shunt pump 22, 23
 - specifications 17
 - starting up 51
 - supply pressure 28
 - symbol
 - installation engineer 8
 - service engineer 8
 - user 8
- T**
 - target groups 8
 - to shut down
 - electrically isolating 53
 - longer period 53
 - short period 53
 - trademarks 3
- U**
 - user 8
- W**
 - warranty 65
 - exclusions 66
 - general 65
 - installation and conditions of use 65
 - scope 66
 - water
 - composition 16

Free Manuals Download Website

<http://myh66.com>

<http://usermanuals.us>

<http://www.somanuals.com>

<http://www.4manuals.cc>

<http://www.manual-lib.com>

<http://www.404manual.com>

<http://www.luxmanual.com>

<http://aubethermostatmanual.com>

Golf course search by state

<http://golfingnear.com>

Email search by domain

<http://emailbydomain.com>

Auto manuals search

<http://auto.somanuals.com>

TV manuals search

<http://tv.somanuals.com>