

Single and Parallel Installation

MGE™ Galaxy™ 3500
10-30 kVA 208/220 V



APC™
by Schneider Electric

American Power Conversion Legal Disclaimer

The information presented in this manual is not warranted by the American Power Conversion Corporation to be authoritative, error free, or complete. This publication is not meant to be a substitute for detailed operational and site specific development plan. Therefore, American Power Conversion Corporation assumes no liability for damages, violations of codes, improper installation, system failures, or any other problems that could arise based on the use of this Publication.

The information contained in this Publication is provided as is and has been prepared solely for the purpose of evaluating data center design and construction. This Publication has been compiled in good faith by American Power Conversion Corporation. However, no presentation is made or warranty, either express or implied, as to the completeness or accuracy of the information this Publication contains.

NO EVENT SHALL AMERICAN POWER CONVERSION CORPORATION BE LIABLE FOR ANY DIRECT, INDIRECT, CONSEQUENTIAL, PUNITIVE, SPECIAL, OR INCIDENTAL DAMAGES (INCLUDING, WITHOUT LIMITATION, DAMAGES FOR LOSS OF BUSINESS, CONTRACT, REVENUE, DATA, INFORMATION, OR BUSINESS INTERRUPTION) RESULTING FROM, ARISING OUT, OR IN CONNECTION WITH THE USE OF, OR INABILITY TO USE THIS PUBLICATION OR THE CONTENT, EVEN IF AMERICAN POWER CONVERSION CORPORATION HAS BEEN EXPRESSLY ADVISED OF THE POSSIBILITY OF SUCH DAMAGES. AMERICAN POWER CONVERSION CORPORATION RESERVES THE RIGHT TO MAKE CHANGES OR UPDATES WITH RESPECT TO OR IN THE CONTENT OF THE PUBLICATION OR THE FORMAT THEREOF AT ANY TIME WITHOUT NOTICE.

Copyright, intellectual, and all other proprietary rights in the content (including but not limited to software, audio, video, text, and photographs) rests with American Power Conversion Corporation or its licensors. All rights in the content not expressly granted herein are reserved. No rights of any kind are licensed or assigned or shall otherwise pass to persons accessing this information.

This Publication shall not be for resale in whole or in part.

Table of Contents

IMPORTANT SAFETY INSTRUCTIONS – SAVE THESE INSTRUCTIONS	1
Specifications	2
AC Input Specifications	2
AC Bypass Input Specifications	2
AC Output Specifications	3
Battery Specifications	3
Recommended Cable Sizes	4
Connection Terminals	4
Torque Specifications	4
Fuses and Breakers	5
Single Utility/Mains System	5
Dual Utility/Mains System	5
Parallel System	6
Fuse and Breaker Sizes in Single Systems	6
Fuse and Breaker Sizes in Parallel Systems	6
Minimum Breaker Settings	7
Mechanical Installation	8
Clearance	8
Level the Cabinet	8
Remove the Front Panel	9
Floor Anchoring	9
Hole Positions for a Stand-alone UPS Enclosure with L-shaped Anchoring Brackets	10
Hole Positions for Up to Four UPS Units in Parallel with U-shaped Anchoring Brackets	10
Connect Floor Anchoring Brackets to the UPS and XR Battery Enclosure for Stability	11
Remove the Battery Modules	12
Install the Baying Kit (Optional) for Interconnection of Enclosures and Seismic Anchoring	13
Install XR Battery Enclosures (Option)	16
Remove the Cable Landing Cover and Bottom Plates	16
Connect Battery Power in Installations with Busbars	17
Isolator Installation Principle	17

Install Busbars in 523 mm (20.59 in) UPS System with the UPS Placed to the Left (seen from the front)	18
Install Busbars in 523 mm (20.59 in) UPS System with the UPS Placed to the Right (seen from the front)	19
Install Busbars in 352 mm (13.85 in) UPS System with the UPS Placed to the Right (seen from the front)	20
Install Busbars in 352 mm (13.85 in) UPS System with the UPS Placed to the Left (seen from the front)	21
Connect Battery Power in Installations with Cables	22
Connect Power Cables Between the UPS and the XR Battery Enclosure	22
Connect Power Cables between Two XR Battery Enclosures	23
Connect the Power Cables to the UPS	25
Single System 10-30 kVA 208 V	25
Single System 10-30 kVA 480 V	26
Prepare for Cables	27
Bottom Cable Entry	27
Connect the AC Input and AC Output Cables	28
Single Mains	28
Dual Mains	28
Connect the DC Battery Cables (if applicable)	29
Connect the Communication Cables	30
Prepare for Communication Cables	30
Overview of Pin Connections	31
J106	31
EPO in Single Systems	32
EPO in Parallel Systems	33
Connect Communication Cables between UPS and XR Battery Enclosure	34
Connect APC Communication Options	35
Connect Communication Cables in Parallel System	36
Overview of the PBus Cables	36
Prepare for Cables	37
UPS Units Apart without Conduits and Interconnection	38
UPS Units Bayed Together without Conduits	39
UPS Units Apart or Bayed Together with Conduits	40
Install Seismic Option	42
Install the Seismic Battery Lock	42

Install the Seismic Stabilizing Brackets	42
Final Mechanical Installation	44
Connect Battery Securing Brackets for Stability	44
Reinstall the Top Cover and the Front Panel	45

IMPORTANT SAFETY INSTRUCTIONS – SAVE THESE INSTRUCTIONS



WARNING: ALL safety instructions in the Safety Sheet (990-2940) must be read, understood, and followed when installing the UPS system. Failure to do so could result in equipment damage, serious injury, or death.



WARNING: After the UPS has been electrically wired, do not start it up. Start-up is commissioned to authorized personnel from Schneider Electric.



WARNING: When the UPS input is connected through external isolators that, when opened, isolate the neutral, or is connected to an IT power distribution system, a label must be fitted at the UPS input terminals by the UPS supplier, and on all primary power isolators installed remote from the UPS area and on external access points between such isolators and the UPS by the user, displaying the following text (or equivalent): "Risk of voltage backfeed. Before working on this circuit, isolate the UPS and check for hazardous voltage between all terminals including the protective earth."



Caution: All electrical power and power control wiring must be installed by a qualified electrician and must comply with local and national regulations for maximum power rating.



Caution: Wait until the system is ready to be powered up before installing batteries. Failure to do so can result in a deep discharge of the batteries and cause permanent damage (the time from the battery installation time till the UPS is powered up should not exceed 72 hours or 3 days).



Note: The system is designed for connection to an IT power distribution system.



Note: The parallel cables must be run by the electrician but not attached. The field service engineer from Schneider Electric will install the parallel communication box and attach all cables to the UPS units.



Note: Up to four UPS units can run in parallel.



Note: Ensure that all UPS units are in their final location prior to the installation.



Note: Battery and utility/mains power must not be connected until all other wiring has been completed.

Specifications



WARNING: The UPS must be supplied from a 208/120 V or 220/127 V 4W + GND 60 HZ source.

AC Input Specifications

	10 kVA		15 kVA		20 kVA		30 kVA	
	208 V	220 V	208 V	220 V	208 V	220 V	208 V	220 V
Connection type	4-wire (3PH + N + G)							
Input frequency (Hz)	40-70							
I thd	< 5% at full load							
Nom input current (A)	24.3	23.0	36.6	34.6	48.6	45.8	73.2	69.0
Max input current (A)	26.7	25.2	40.2	38.0	53.0	50.1	80.1	75.8
Input current limitation (A)	32.8	32.8	49.5	49.5	65.2	65.2	98.8	98.8
Input power factor correction	> 0.98 at load > 50%							
Maximum Short Circuit Withstand (kA)	30							

AC Bypass Input Specifications

	10 kVA		15 kVA		20 kVA		30 kVA	
	208 V	220 V	208 V	220 V	208 V	220 V	208 V	220 V
Connection type	4-wire (3PH + N + G)							
Input frequency (Hz)	50 +/- 10 or 60 +/- 10							
Nom input current (A)	27.8	26.2	41.6	39.4	55.5	52.5	83.3	78.7

AC Output Specifications

	10 kVA		15 kVA		20 kVA		30 kVA	
	208 V	220 V	208 V	220 V	208 V	220 V	208 V	220 V
Connection type	4-wire (3PH + N + G)							
Overload capacity	150% for 1 minute (normal operation) 125% for 10 minutes (normal operation) 150% for 1 minute (battery operation) 125% for 10 minutes (battery operation) 110% continuous (bypass operation) 800% for 500 ms (bypass operation)							
Voltage tolerance	160-240 V for 208 V systems 160-253 V for 220 V systems							
Nom output current (A)	27.8	26.2	41.6	39.4	55.5	52.5	83.3	78.7
Output frequency (sync to mains)	50 Hz \pm 0.1 Hz, \pm 3 Hz, \pm 10 Hz 60 Hz \pm 0.1 Hz, \pm 3 Hz, \pm 10 Hz							
Slew rate (Hz/Sec)	0.25-1							
Total Harmonic Distortion (THD)	< 1.5% linear < 3.5% non-linear							
Load power factor	0.5 leading to 0.5 lagging							
Dynamic load response	\pm 5%							
Output voltage regulation	\pm 1%							

Battery Specifications

Type	VRLA
Nominal voltage (VDC)	+/- 192
Float voltage (VDC)	+/- 219
End of discharge voltage (VDC)	+/- 154
Battery current (at full load)	66.5 A at +/-192 V
Max. current (at end of discharge)	83.2 A at + 154 V
Max. charging power	10 kVA: 1600 W 15 kVA: 2400 W 20 kVA: 3200 W 30 kVA: 3200 W
Typical re-charge time	5 hours
End voltage	1.6-1.75 V/cell (automatic, depending on load)

Recommended Cable Sizes



WARNING: At 100% switch mode load, the neutral must be rated for 200% phase current.



Caution: All wiring must comply with all applicable national and/or electrical code.



Note: The recommended cable sizes are based on an environment with an ambient temperature of 30° C (86° F). Use stranded copper cables.

	10 kVA	15 kVA	20 kVA	30 kVA
Utility/mains input	8 AWG	6 AWG	4 AWG	1 AWG
Static bypass input	8 AWG	6 AWG	4 AWG	1 AWG
DC input	1 AWG	1 AWG	1 AWG	1 AWG
Output	8 AWG	6 AWG	4 AWG	1 AWG

Connection Terminals

Cable size (AWG)	Cable lug type	Crimping tool	Die	Terminal bolt diameter
12	YA12CL2TC38	MD7-34R	W12CVT	6 mm (0.2 in)
8	YA8CL2TC38	MD7-34R	W8CVT	6 mm (0.2 in)
6	YA6CL2TC38	MD7-34R	W6CVT	6 mm (0.2 in)
4	YA4CL2TC38	MD7-34R	W4CVT	6 mm (0.2 in)
1	YA1CL2TC38	MD7-34R	W1CVT	6 mm (0.2 in)

Torque Specifications

The power wiring should be torqued to 7 Nm (45 lbf-in).

Fuses and Breakers

Single Utility/Mains System

- Q1: Utility/mains input
- Q2: UPS output
- Q3: Manual bypass
- MBS: Mechanical bypass switch

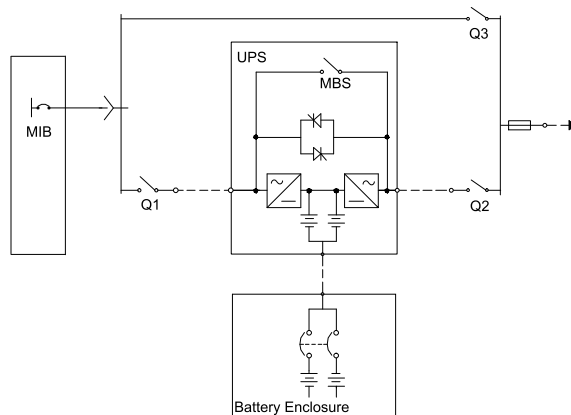

Dual Utility/Mains System

- Q1: Utility/mains input
- Q2: UPS output
- Q3: Manual bypass
- Q5: Static bypass input
- MBS: Mechanical bypass switch

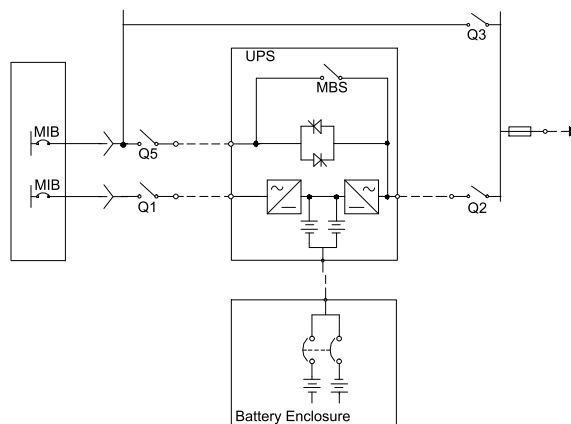

Parallel System

- Q1: Utility/mains input
- Q2: UPS output
- Q3: Manual bypass
- Q4: System output
- Q5: Static bypass input

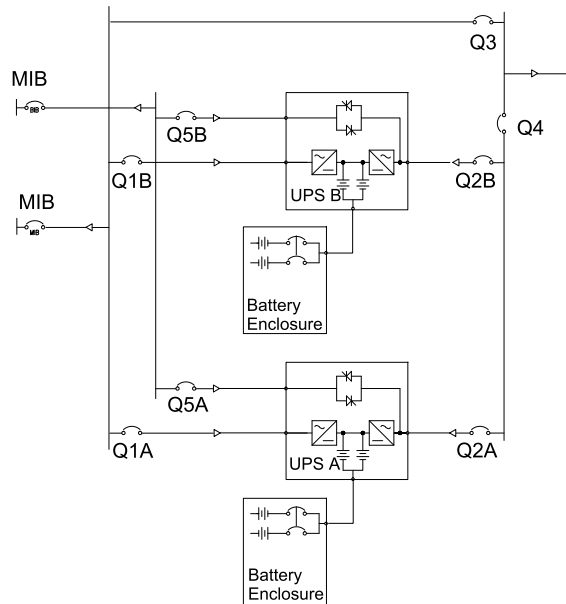

Fuse and Breaker Sizes in Single Systems

	10 kVA	15 kVA	20 kVA	30 kVA
Utility input Q1	35 A	60 A	80 A	110 A
Static bypass input Q5	35 A	60 A	80 A	110 A
UPS output Q2	35 A	60 A	80 A	110 A
Manual bypass Q3	35 A	60 A	80 A	110 A

Fuse and Breaker Sizes in Parallel Systems

Q3 and Q4 in Parallel Capacity Systems

Units in parallel	10 kVA	15 kVA	20 kVA	30 kVA
2	70 A	110 A	150 A	225 A
3	110 A	175 A	225 A	350 A
4	150 A	225 A	300 A	450 A

Q3 and Q4 in Redundant Parallel Systems (n+1)

Units in parallel	10 kVA	15 kVA	20 kVA	30 kVA
2	35 A	60 A	80 A	110 A
3	70 A	110 A	150 A	225 A
4	110 A	175 A	225 A	350 A

Minimum Breaker Settings

		800% overload bypass operation	150% overload normal/battery operation	125% overload normal/battery operation	Continuously
	Duration	500 ms	60 s	10 min	
10 kVA	Mains input	- ¹	-	-	34 A
	Static bypass input	223 A	-	-	31 A
	UPS output	223 A	42 A	35 A	31 A
15 kVA	Mains input	- ¹	-	-	51 A
	Static bypass input	333 A	-	-	46 A
	UPS output	333 A	63 A	52 A	46 A
20 kVA	Mains input	- ¹	-	-	68 A
	Static bypass input	444 A	-	-	62 A
	UPS output	444 A	84 A	70 A	62 A
30 kVA	Mains input	- ¹	-	-	99 A
	Static bypass input	667 A	-	-	92 A
	UPS output	667 A	125 A	105 A	92 A
¹ For single mains systems, use the higher value of mains and static bypass					

Mechanical Installation

Clearance



Note: Clearance dimensions are published for airflow and service access only. Consult with the local safety codes and standards for additional requirements in your local area.

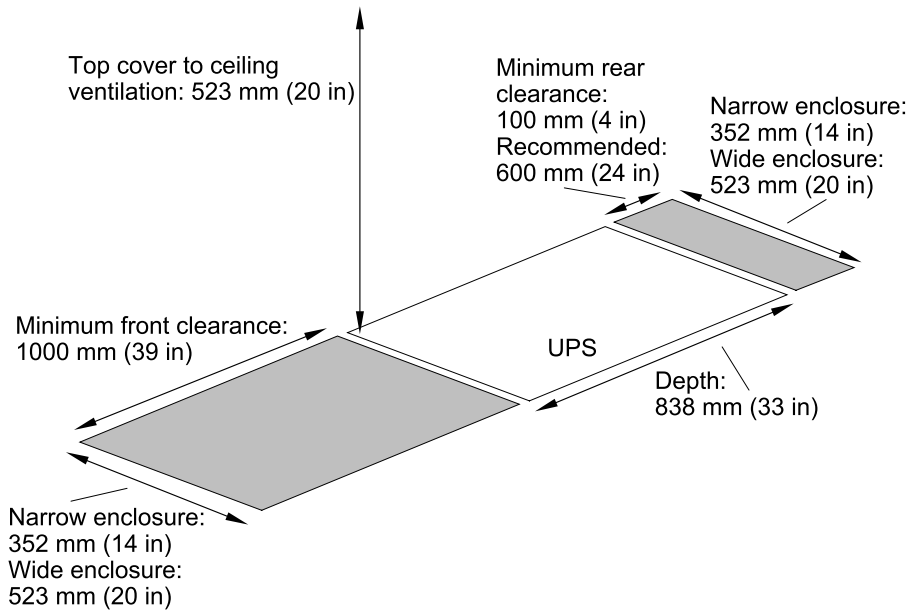

Level the Cabinet



WARNING: The system must be installed on a level floor. The leveling feet will stabilize the cabinet, but will not account for a badly sloped floor.

1. Take the 13/14 mm wrench attached to the pallet.
2. Adjust the four leveling feet and ensure that the system is level.

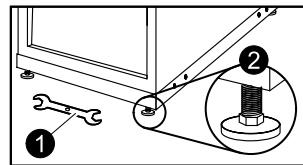

Note: Do not move the cabinet after the leveling feet have been lowered.

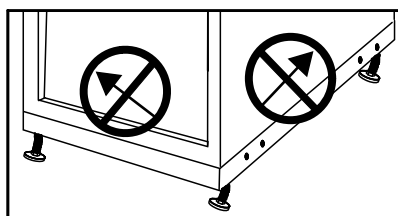

Remove the Front Panel

1. Use a coin or similar to turn the two black lock devices on either side of the display in the direction of each other to a vertical position.
2. Push the front panel upwards and pull it outwards to disengage the locking device at the top of the enclosure.
3. Lift the front panel free of the two slots at the bottom of the enclosure.

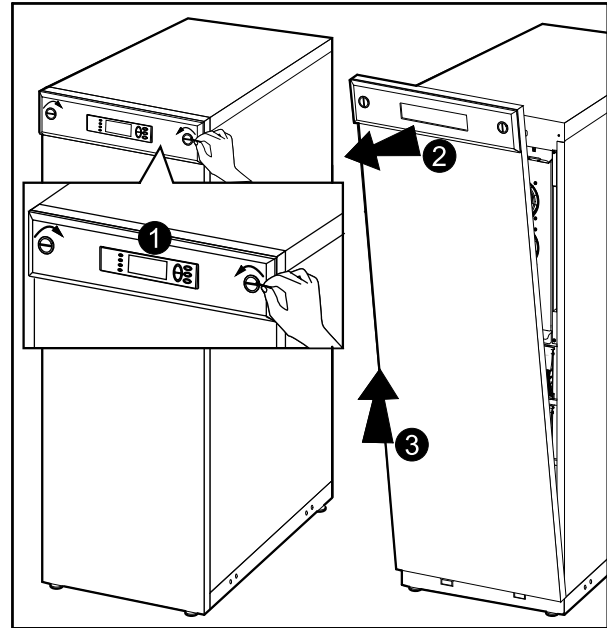

Floor Anchoring

There are two floor anchoring options that can be used depending on the requirements in the installation area:

- For stability: Reuse the L-shaped brackets that secured the enclosure to the pallet during shipment for a stand-alone UPS.
- For seismic anchoring: Use a baying kit that includes U-shaped seismic anchoring brackets.



Note: Allow for enough working space behind the enclosure for electrical work to be carried out (e.g. if you want to install an XR Battery Enclosure at a later stage). Minimum rear clearance is 100 mm (3.93 in) and must comply with applicable national and local codes. 600 mm (23.6 in) is recommended.



Note: Hole positions are guidelines only.

Hole Positions for a Stand-alone UPS Enclosure with L-shaped Anchoring Brackets



Note: Recommended minimum number of screws per enclosure for the L-shaped brackets is four; one in each corner. Recommended floor bolt size: M8.

Model Width: 352 mm (13.85 in) and 523 mm (20.59 in)

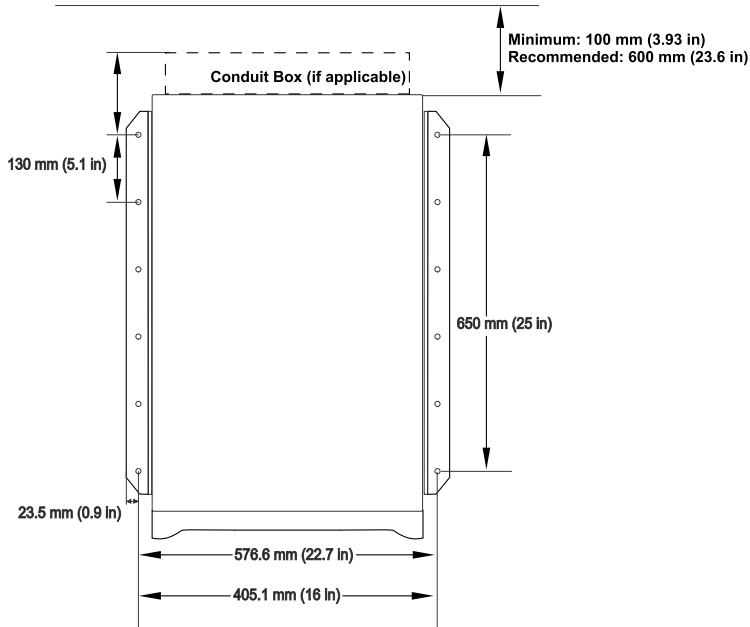

Hole Positions for Up to Four UPS Units in Parallel with U-shaped Anchoring Brackets



Note: Recommended minimum number of floor screws for the two configurations below is 10.

Model Width: 352 mm (13.85 in)

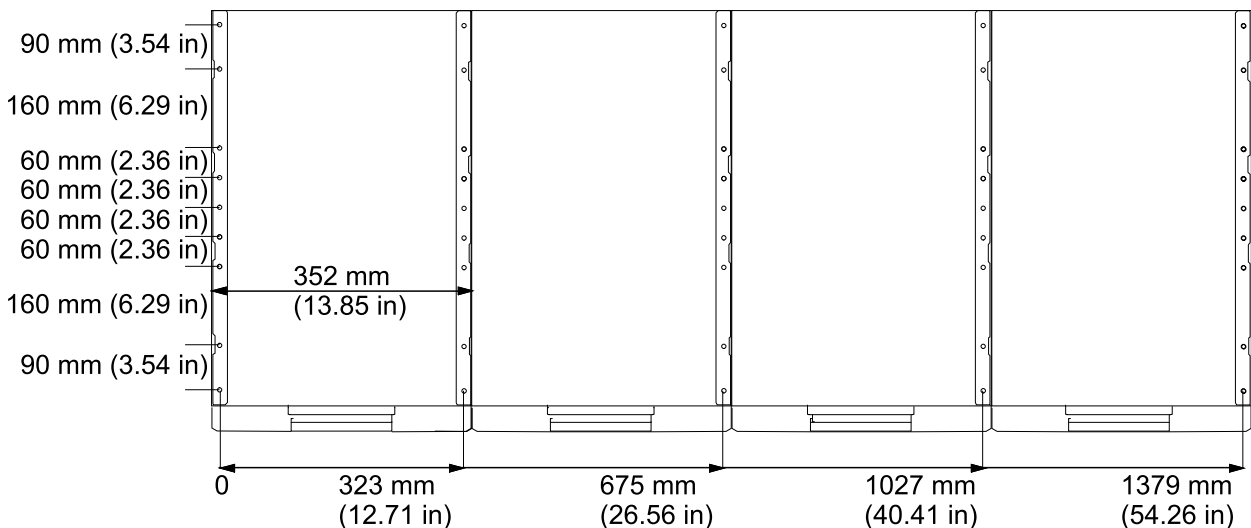

Model Width: 523 mm (20.59 in)

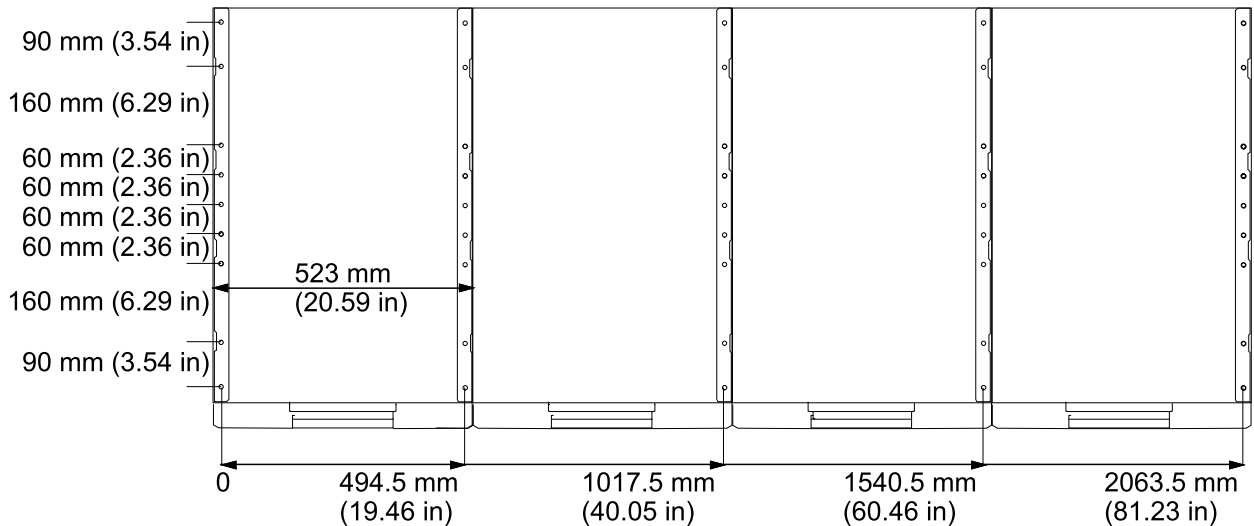

Connect Floor Anchoring Brackets to the UPS and XR Battery Enclosure for Stability



Note: Floor anchoring bolts are not provided with the UPS. Purchase the bolts locally (minimum size: M8). Follow the specifications given by the manufacturer of the floor anchoring system when bolting the UPS system to the floor.

1. Install the L-shaped floor anchoring brackets (reuse the two transport brackets) and secure with the M6 screws and nuts (provided).
2. Drill two to six holes in the floor for each bracket and attach these with bolts.

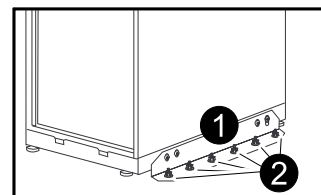

Remove the Battery Modules



Note: Two people are needed to lift the battery modules.



Note: The XR Battery Enclosures ship with two battery modules. All battery modules in the UPS and the XR Battery Enclosure(s) must be removed before interconnecting these enclosures.



Note: When you remove battery modules, start from the highest row and work your way down.

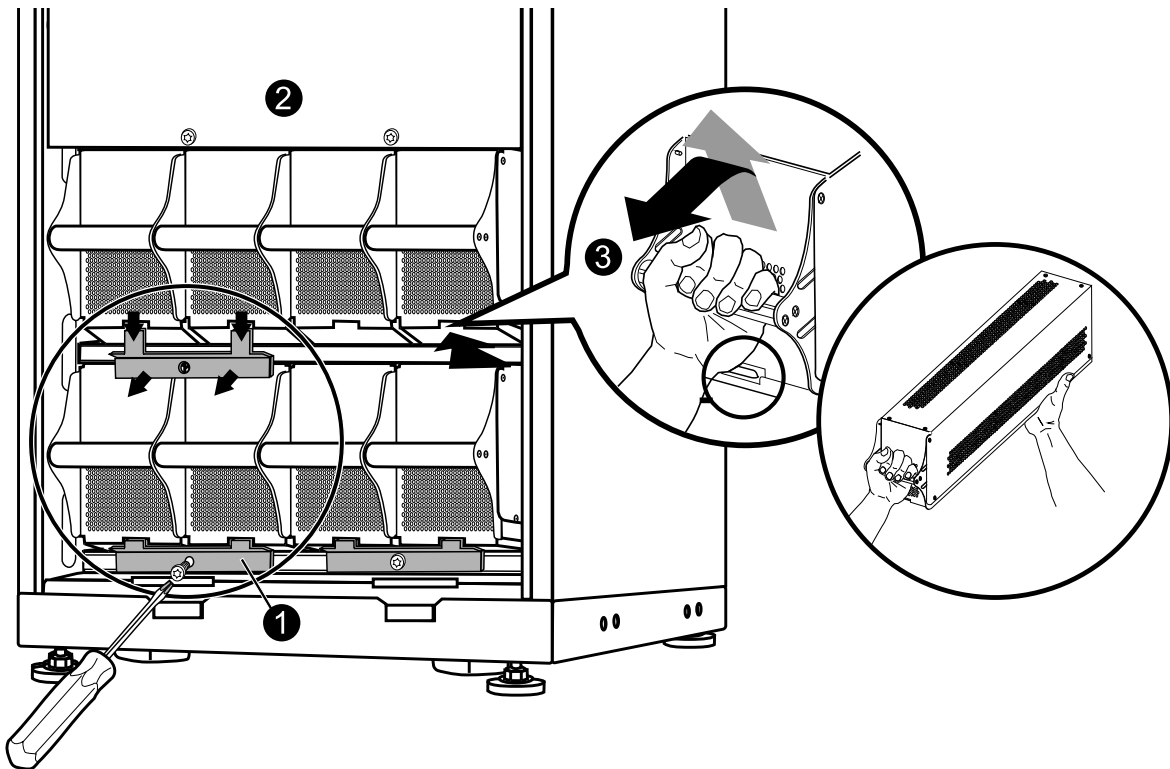

1. Remove all battery securing brackets (used to secure the batteries during transport) by removing the M6 Torx screws.
2. Remove the blind plate.
3. To release the battery from its lock mechanism, gently push the battery upwards and then pull it out while supporting the battery with your other hand.

Install the Baying Kit (Optional) for Interconnection of Enclosures and Seismic Anchoring



Caution: Baying kits are required in seismic areas.

1. Remove the side panels from the enclosure(s) to get access to the holes in the bottom frame.

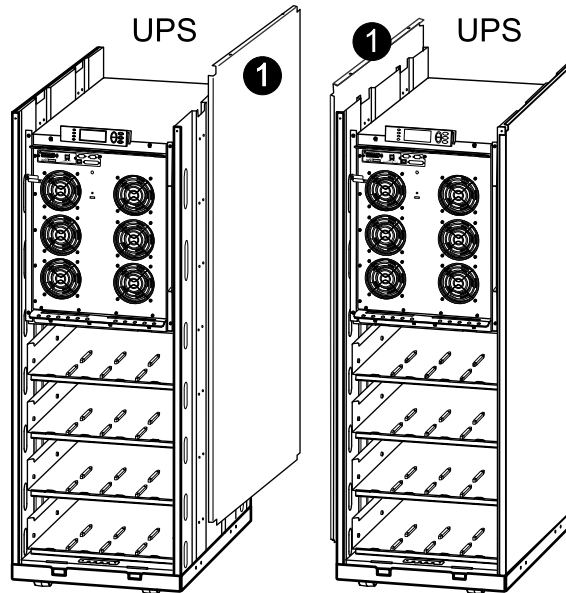

Note: Make sure that the enclosures are level so that they can be anchored to each other.

2. Position two U-shaped floor anchoring brackets under one enclosure; one on each side.

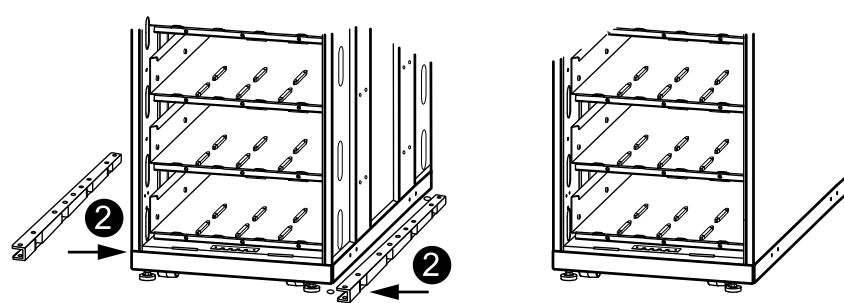

Note: The U-shaped anchoring brackets are 1-2 mm higher than the opening below the enclosure to inactivate the casters. Therefore, the enclosure must be tilted when placing the U-shaped anchoring brackets under the enclosure.

3. On each side of the same enclosure insert a maximum of nine and a minimum of two M8 screws (not provided) through holes in the bottom of the enclosure and through holes in the U-shaped floor anchoring brackets, and into the pre-drilled floor holes.

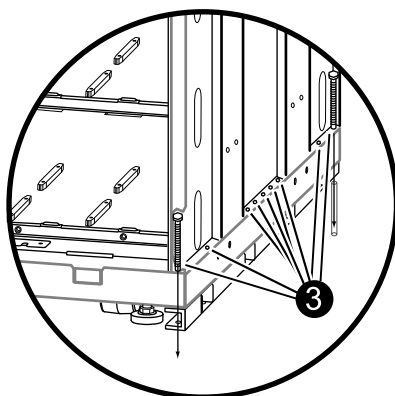

4. Fasten the screws.

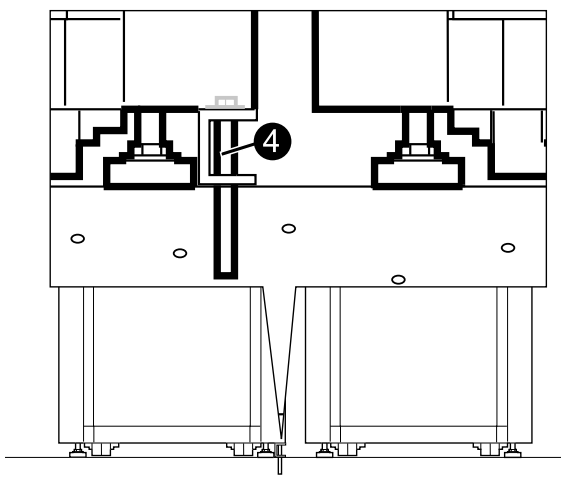

5. Move the adjacent enclosure on its casters close to the enclosure with the U-shaped floor anchoring brackets.



Note: If the adjacent enclosure is on its leveling feet, use a forklift or pallet jack to move it into position to avoid damaging the leveling feet.

6. Insert the interconnection plates between the two enclosures. One is positioned toward the front and the other toward the rear. Notice how the “wings” on the interconnection plates rest in slots at the top of the inner panel.

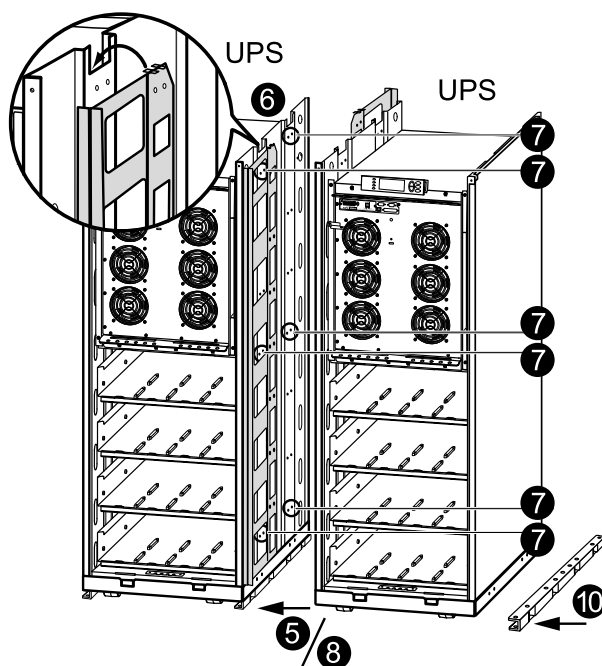

7. Align the two enclosures and level the three marked rows of bolt holes in UPS 1 with the holes in UPS 2.
8. Push the two enclosures firmly together.
9. Bolt the two enclosures together using the six M6x25 mm screws and nuts supplied in the kit; join one hole at the front and one hole at the rear of the enclosures on three levels.

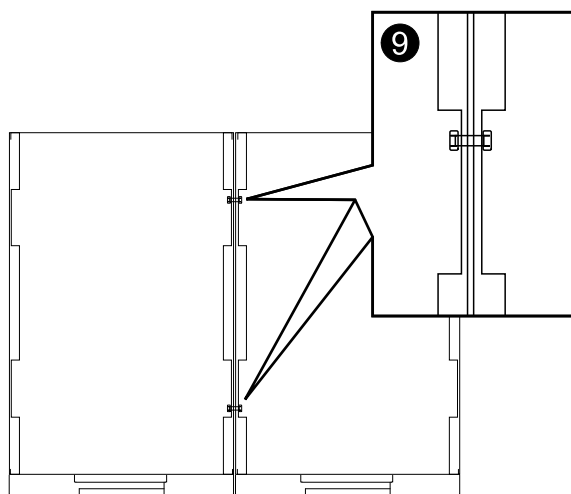

10. Position the third U-shaped floor anchoring bracket under the adjacent enclosure (see previous graphics) and insert a minimum of two floor anchoring M8 screws (not provided) through the holes in the bottom of the enclosure and through the holes in the U-shaped floor anchoring bracket, and into the predrilled floor holes, and then fasten the screws.

Install XR Battery Enclosures (Option)

Remove the Cable Landing Cover and Bottom Plates



WARNING: Before carrying out the steps below, the system must be in total power off and the batteries must be removed.

To access the cable landing area in the UPS and the XR Battery Enclosure(s), follow this procedure:

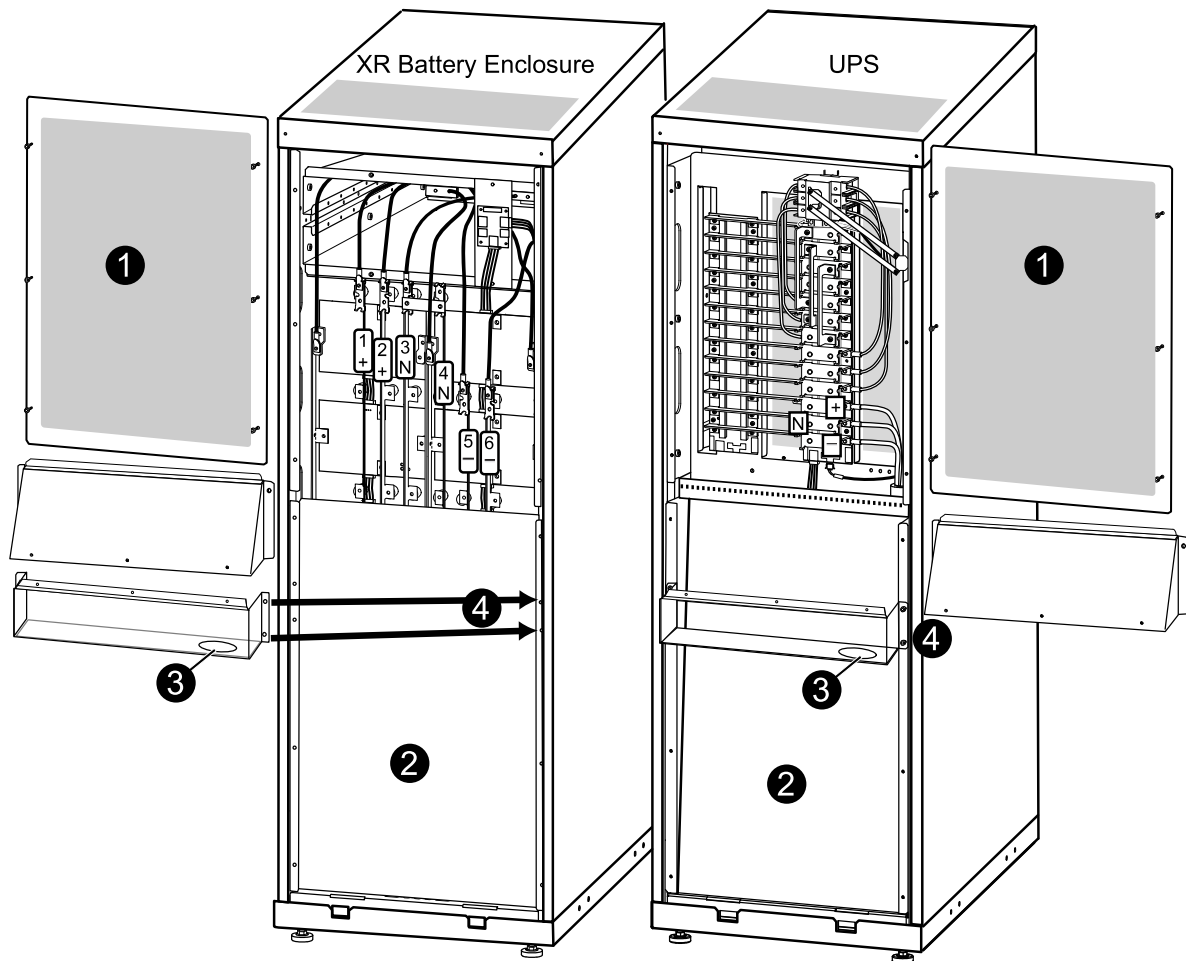

1. Loosen the six M4 screws from the cable landing cover plate on the UPS and the XR Battery Enclosure(s) and then remove the plates.
2. In installations with busbar connections, remove the screws from the bottom plate on the UPS and the XR Battery Enclosure(s) and then remove the plates.
3. Punch holes in the bottom of the conduit boxes to fit the size of the conduit pipes.
4. Attach the bottom part of the conduit boxes to the back of the UPS and to the back of the XR Battery Enclosure with four screws each (if applicable).

Connect Battery Power in Installations with Busbars



WARNING: Before carrying out the steps below, the system must be in total power off and the batteries must be removed.

Isolator Installation Principle

The isolators separate the buying kit busbar from the six vertical busbars in each XR Battery Enclosure, and the (+), N, and (-) busbars in the UPS.

1. Guide the busbar with isolator through the adjacent side panels.

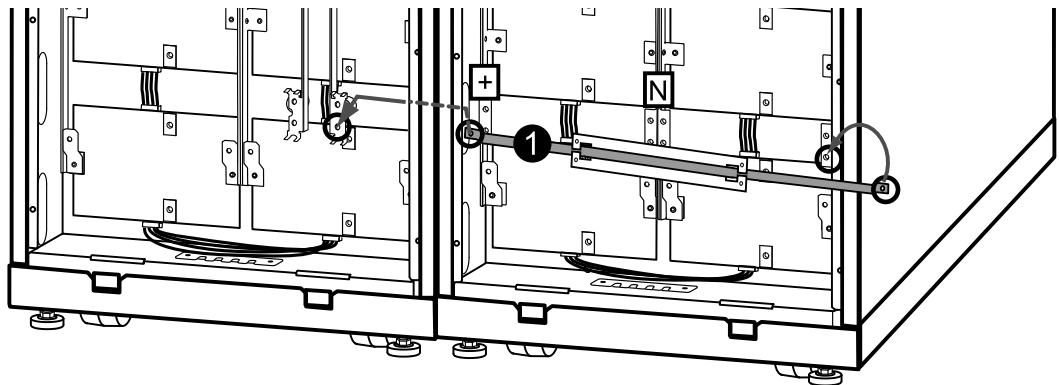

2. Position the isolators across the vertical busbars (N in this example) and then fasten the isolator busbar by using the provided M5 Torx screws.
3. Secure the isolator to its busbar with cable ties.

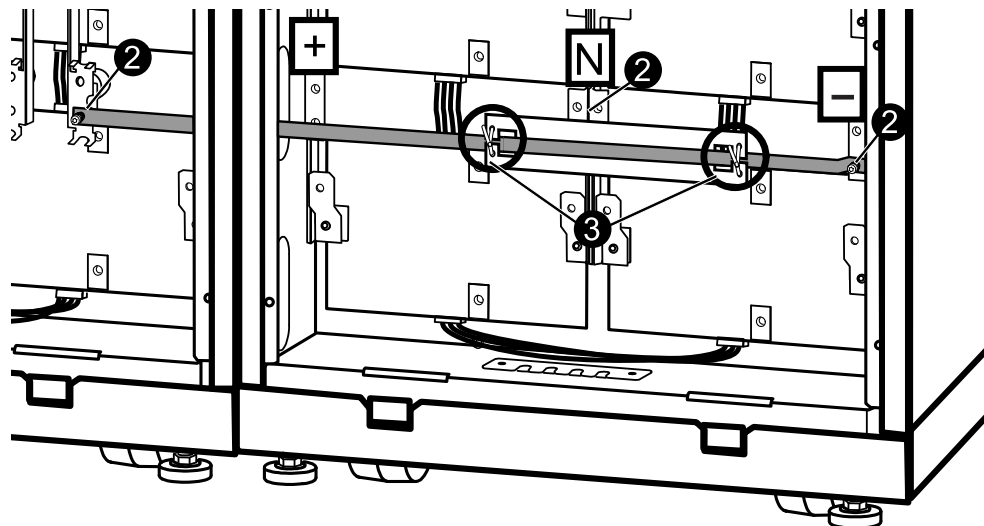

Install Busbars in 523 mm (20.59 in) UPS System with the UPS Placed to the Left (seen from the front)

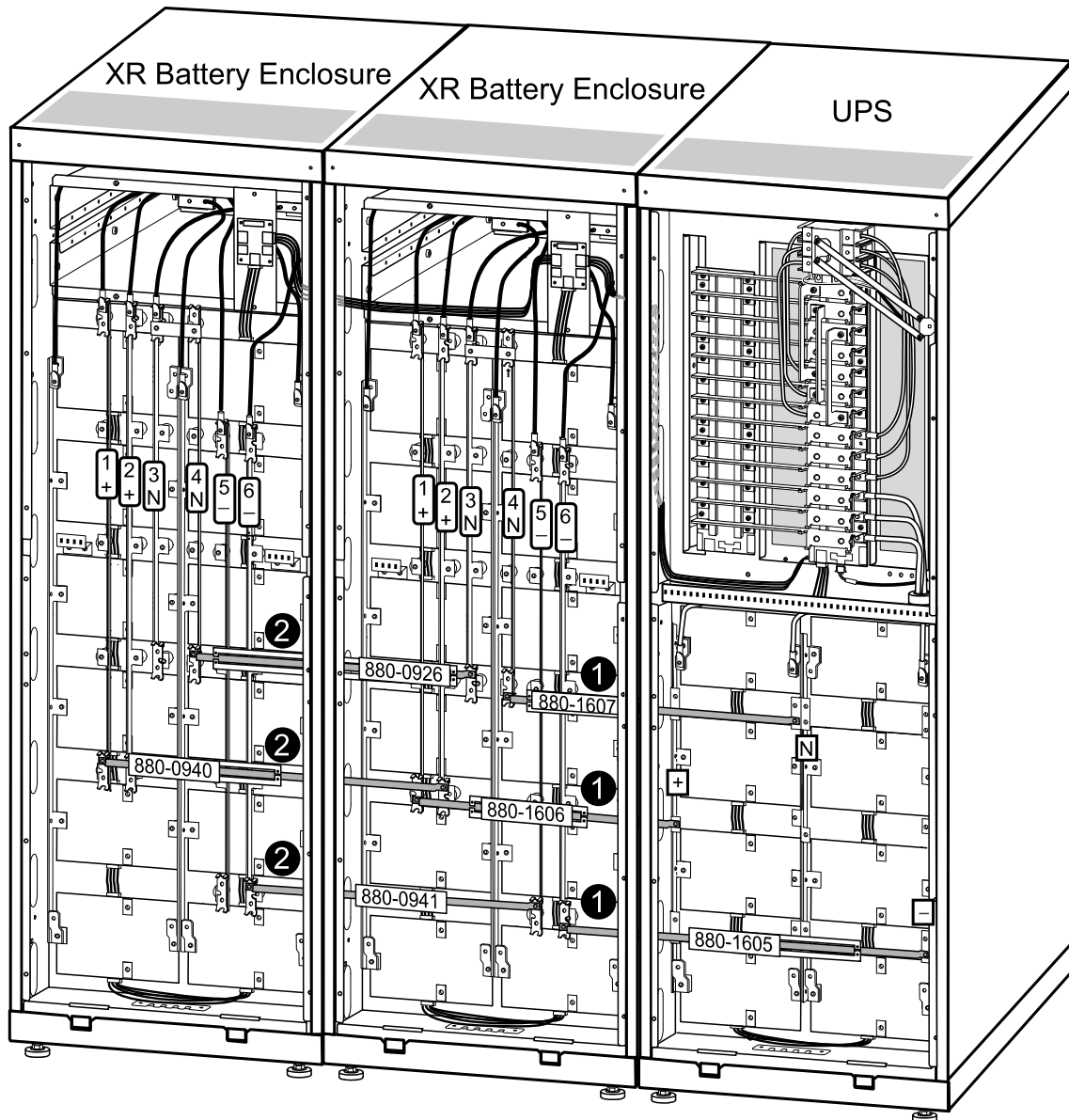

1. Install the following buying kit busbars between the UPS and XR1:
 - 880-1607 between vertical busbar N on the UPS and busbar 4 on XR1
 - 880-1606 between vertical busbar (+) on the UPS and busbar 1 on XR1
 - 880-1605 between busbar (-) on the UPS and busbar 6 on XR1
2. Install the following buying kit busbars between the two XR Battery Enclosures:
 - 880-0926 between vertical busbar 3 on XR1 and busbar 4 on XR2
 - 880-0940 between vertical busbar 2 on XR1 and busbar 1 on XR2
 - 880-0941 between vertical busbar 5 on XR1 and busbar 6 on XR2

Install Busbars in 523 mm (20.59 in) UPS System with the UPS Placed to the Right (seen from the front)

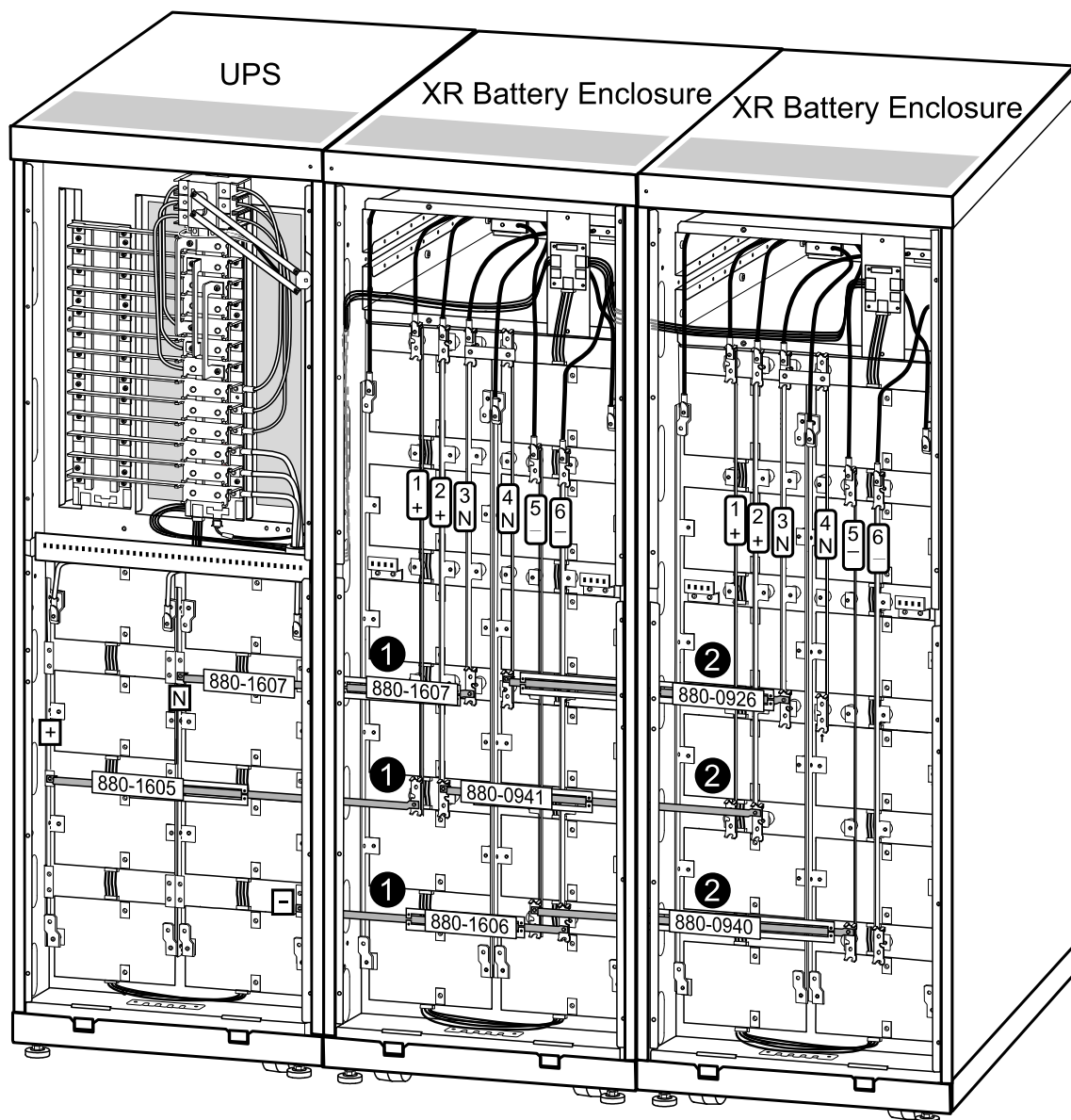

1. Install the following buying kit busbars between the UPS and XR1:
 - 880-1607 between vertical busbar N on the UPS and busbar 3 on XR1
 - 880-1605 between vertical busbar (+) on the UPS and busbar 1 on XR1
 - 880-1606 between vertical busbar (-) on the UPS and busbar 6 on XR1
2. Install the following buying kit busbars between the two XR Battery Enclosures:
 - 880-0926 between vertical busbar 4 on XR1 and vertical busbar 3 on XR2
 - 880-0941 between vertical busbar 2 on XR1 and vertical busbar 2 on XR2
 - 880-0940 between vertical busbar 5 on XR1 and vertical busbar 5 on XR2

Install Busbars in 352 mm (13.85 in) UPS System with the UPS Placed to the Right (seen from the front)

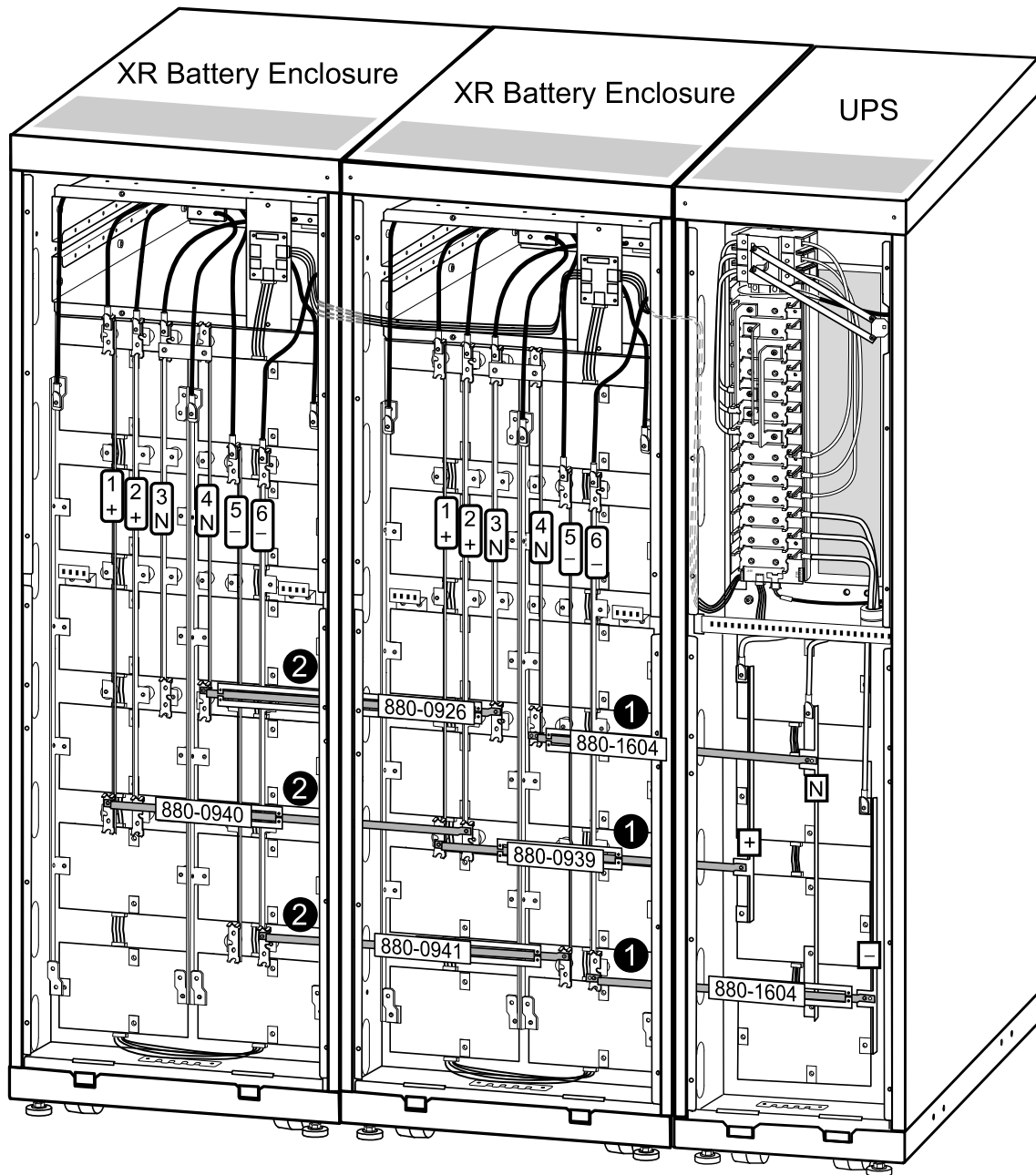

1. Install the following buying kit busbars between the UPS and XR1:
 - 880-1604 between vertical busbar N on the UPS and busbar 4 on XR1
 - 880-0939 between vertical busbar (+) on the UPS and busbar 1 on XR1
 - 880-1604 between vertical busbar (-) on the UPS and busbar 6 on XR1
2. Install the following buying kit busbars between two XR Battery Enclosures:
 - 880-0926 between vertical busbar 3 on XR1 and busbar 4 on XR2
 - 880-0940 between vertical busbar 2 on XR1 and busbar 1 on XR2
 - 880-0941 between vertical busbar 5 on XR1 and busbar 6 on XR2

Install Busbars in 352 mm (13.85 in) UPS System with the UPS Placed to the Left (seen from the front)

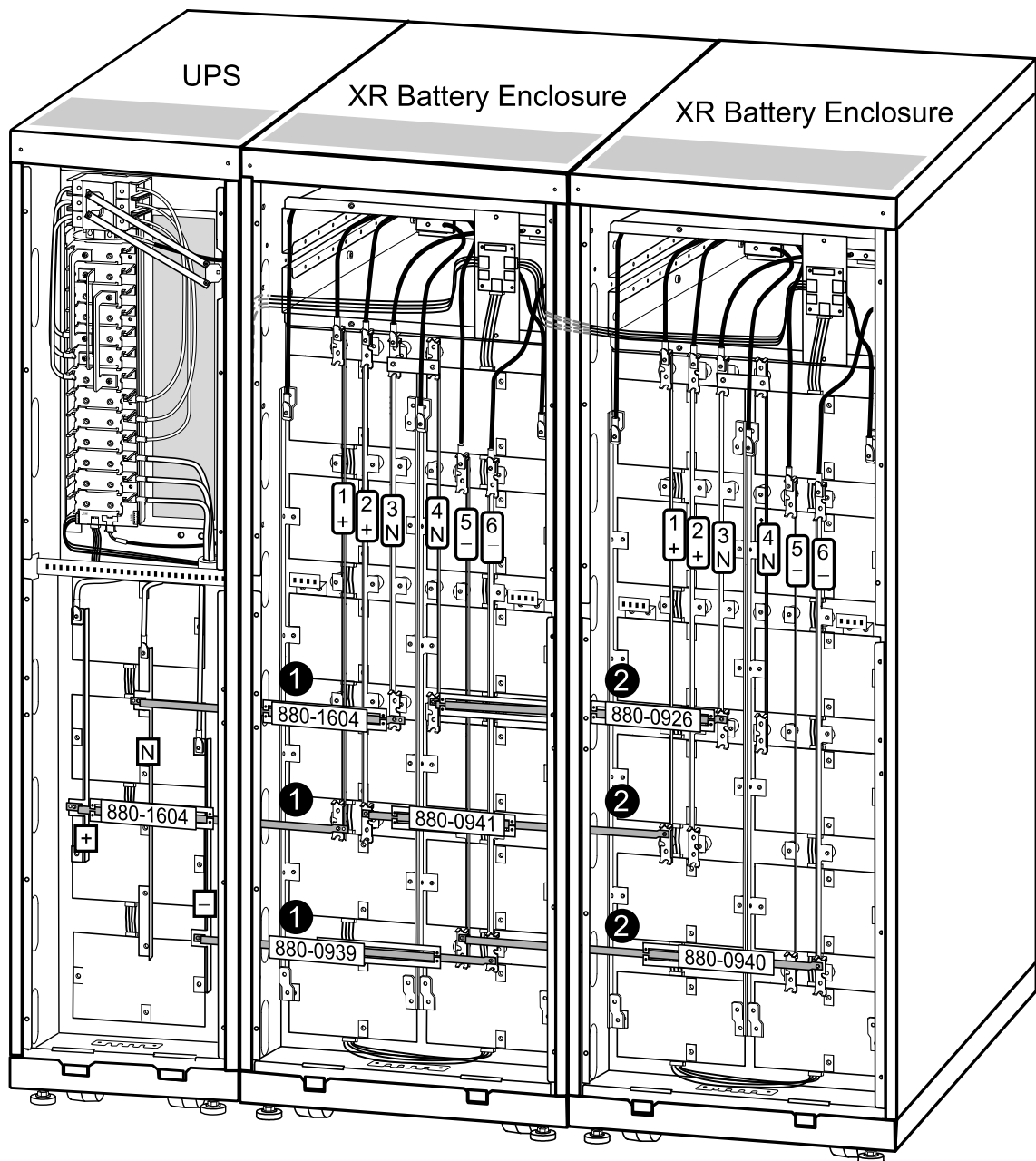

1. Install the following buying kit busbars between the UPS and XR1:
 - 880-1604 between vertical busbar N on the UPS and busbar 3 on XR1
 - 880-1604 between vertical busbar (+) on the UPS and busbar 1 on XR1
 - 880-0939 between vertical busbar (-) on the UPS and busbar 6 on XR1
2. Install the following buying kit busbars between two XR Battery Enclosures:
 - 880-0926 between vertical busbar 4 on XR1 and vertical busbar 3 on XR2
 - 880-0941 between vertical busbar 2 on XR1 and vertical busbar 1 on XR2
 - 880-0940 between vertical busbar 5 on XR1 and vertical busbar 6 on XR2

Connect Battery Power in Installations with Cables

Connect Power Cables Between the UPS and the XR Battery Enclosure



WARNING: Before carrying out the steps below, the system must be in total power off and the batteries must be removed.



WARNING: Each freestanding cabinet must be separately connected to the equipotential bonding system (protective earthing).



Note: The terminals are only suitable for connection of copper cables.

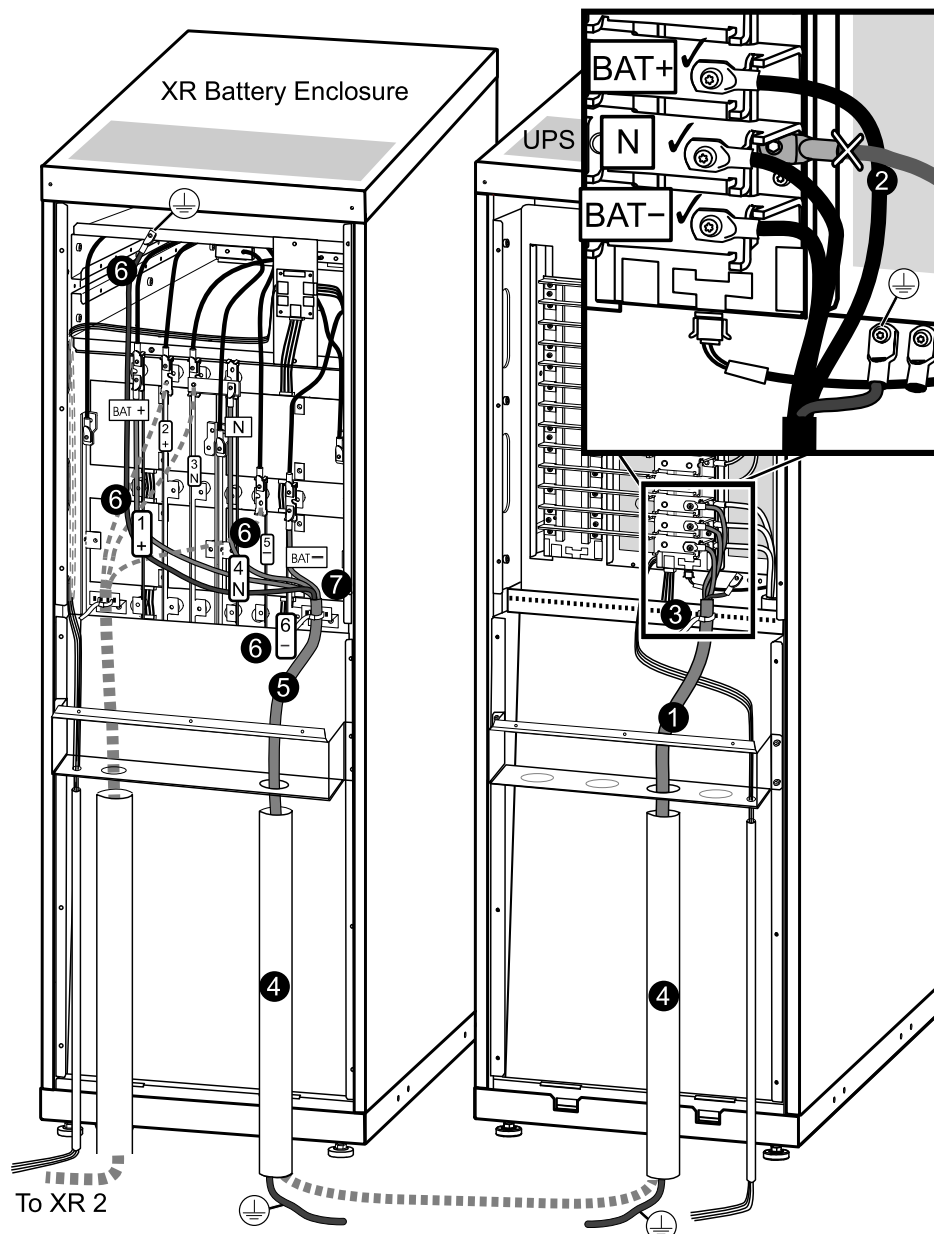

1. In the UPS, feed the cable up through the conduit box or through the transparent cable route bracket (not shown).
2. Connect the BAT+, BAT-, N, and ground cables to the busbars in the UPS.
3. Secure the cables to the perforated bracket with cable ties.
4. Equip the cable with conduits (if applicable).
5. In the XR Battery Enclosure, feed the cable up through the conduit box (if applicable) to the cable landing area.
6. Connect the (+) cable to busbar no. 1 (+), connect the N cable to busbar no. 4 (N), the (-) cable to busbar no. 6 (-), and the ground cable to the terminal in the top of the cabinet. Bundle the cables using the supplied cable ties.
7. Secure the cable to the perforated bracket with cable ties.
8. Attach the top part of the conduit box (if applicable).

Connect Power Cables between Two XR Battery Enclosures



WARNING: Before carrying out the steps below, the system must be in total power off and the batteries must be removed.



WARNING: Each freestanding cabinet must be separately connected to the equipotential bonding system (protective earthing).



Note: The terminals are only suitable for connection of copper cables.

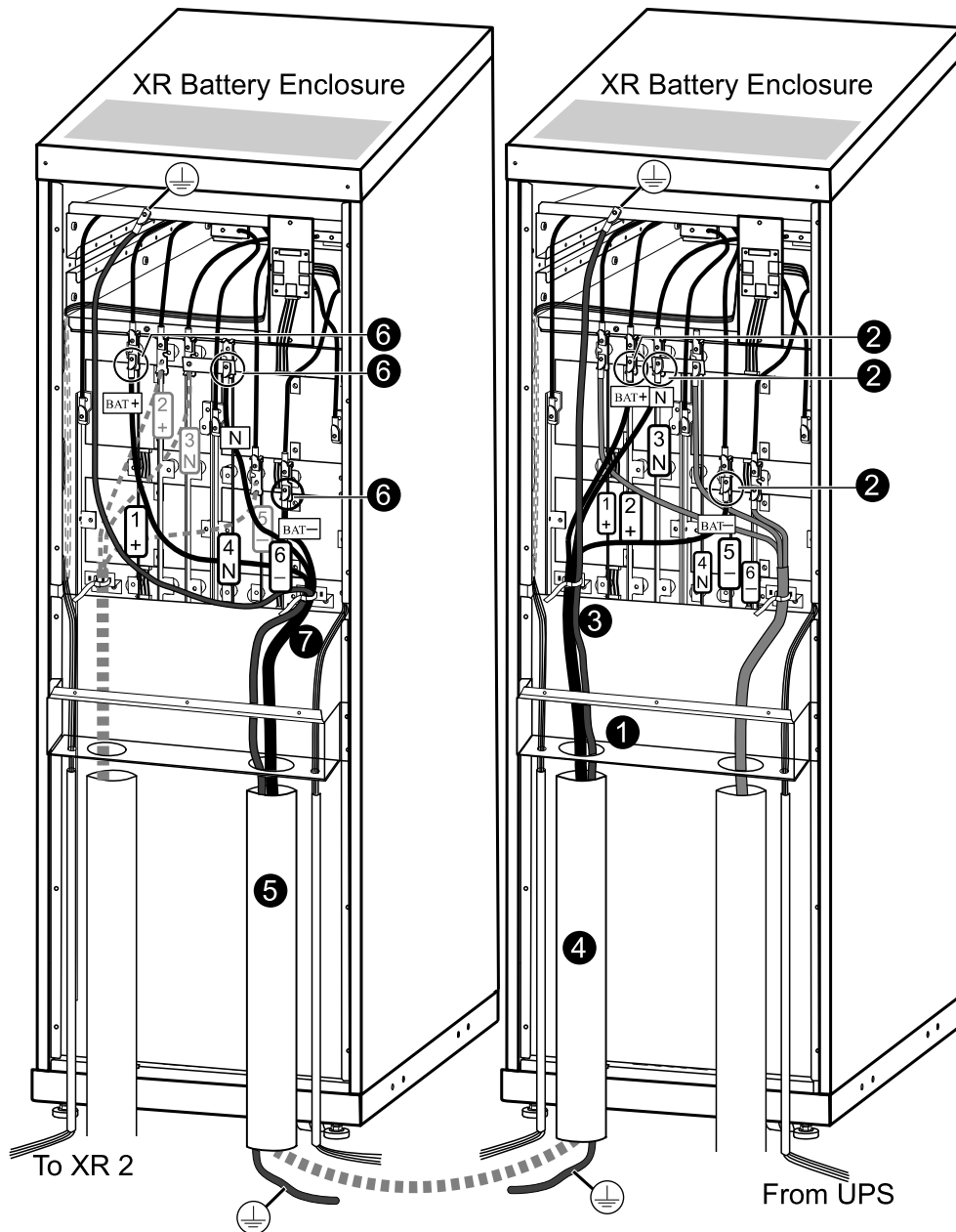

1. Feed the cable up through the conduit box on XR1 or through the transparent cable route bracket (not shown) to the cable connection area.
2. Connect the (-) cable to busbar no. 5 (-), the N cable to busbar no. 3 (N), the (+) cable to busbar no. 2 (+) in XR1, and the ground cable to the terminal in the top of the cabinet.
3. Secure the cable to the perforated bracket with cable ties.
4. Equip the cable with conduits (if applicable).
5. Feed the cable up into the conduit box (optional for 400 V versions) on XR2.
6. Connect the (-) cable to busbar no. 6 (-), the N cable to busbar no. 4 (N), and the (+) cable to busbar no.1 (+) in XR2, and the ground cable to the terminal in the top of the cabinet. Bundle the cables using the supplied cable ties.
7. Secure the cable to the perforated bracket with cable ties.
8. Attach the top part of the conduit box (if applicable).

Connect the Power Cables to the UPS

Single System 10-30 kVA 208 V

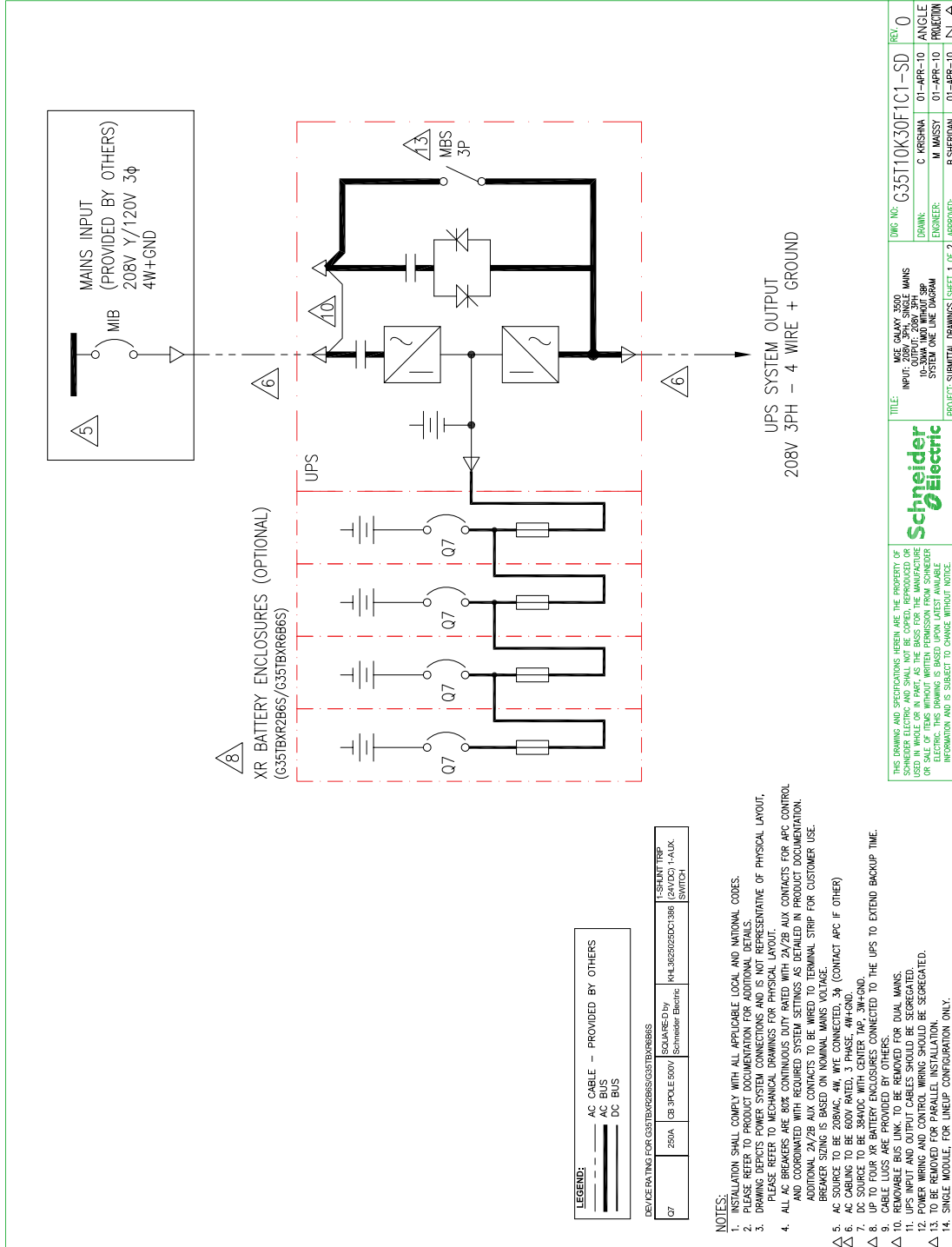

Single System 10-30 kVA 480 V

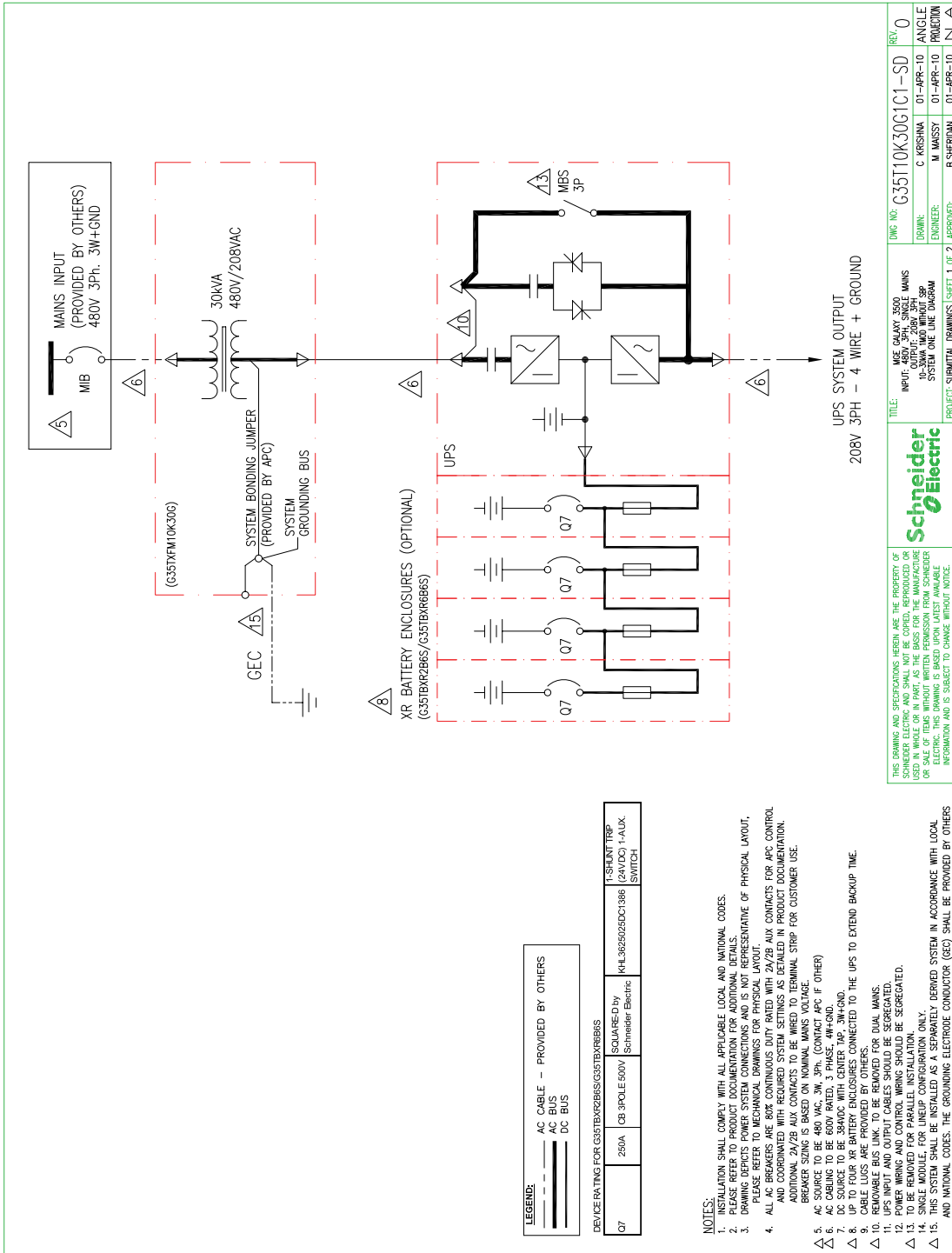

Prepare for Cables

Bottom Cable Entry

1. From the rear of the UPS, loosen the six M4 screws from the upper cover (the cable landing area), and remove. Save the screws for later use
2. Loosen the two M4 screws (one on each side) from the top part of the conduit box. Loosen the M4 screws attaching it to the bottom part (two screws in 352 mm (13.8 in) enclosure three screws in a 523 mm (20 in) enclosure) and remove. Save the screws for later use.
3. Loosen the four M4 screws (two on each side) from the conduit box and remove. Save the screws for later use.

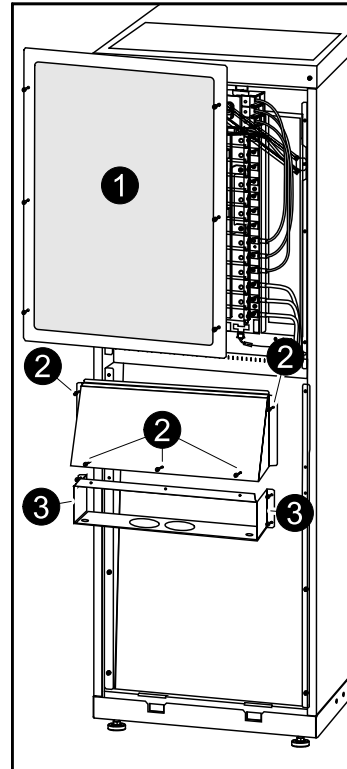

4. Punch as many holes as needed in the marked areas of the bottom conduit box.
5. Attach the conduit box bottom to the enclosure (reuse the screws from step 3).
6. Attach conduits to the conduit box.
7. Run the cables through the conduits, the bottom of the conduit box, and up into the cable landing area.

- A. Bypass
- B. Output
- C. Battery
- D. Input

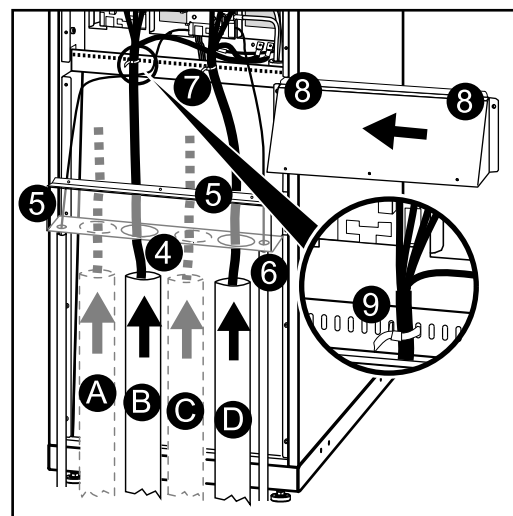

8. Attach conduit box top to the conduit box bottom and to the enclosure reusing the screws from step 2.
9. Fasten the cables with cable ties.

Connect the AC Input and AC Output Cables



WARNING: Use **ONLY** compression type lugs. Do not loosen or add cables to any factory preinstalled cables on busbars. Use the upper front part of busbar for connection only.



Note: The terminals are only suitable for connection of copper cables.

Single Mains

1. Connect the AC input cables and the neutral to the input cable landings.
2. Connect the AC output cables and the neutral to the output cable landings.
3. Connect the ground cables to the studs (earth symbol beneath) using a screw.

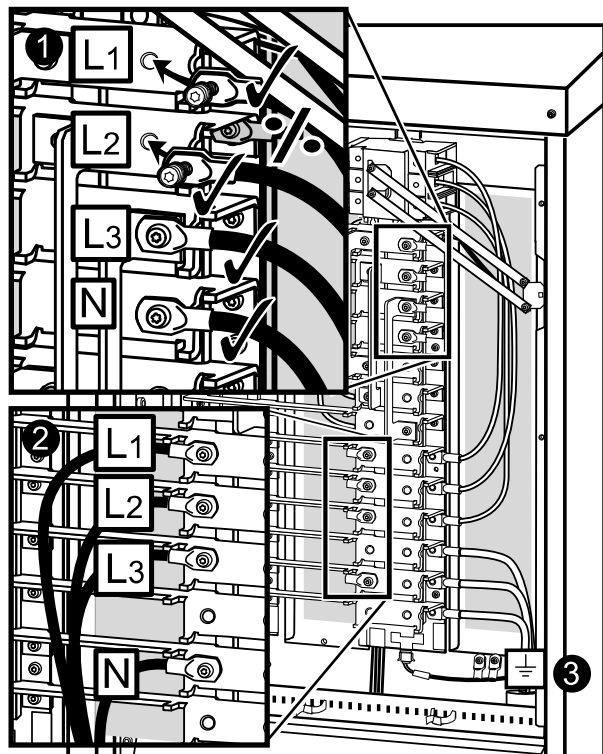

Dual Mains

1. Remove the three busbars A, B, and C by removing two M6 screws from each busbar.

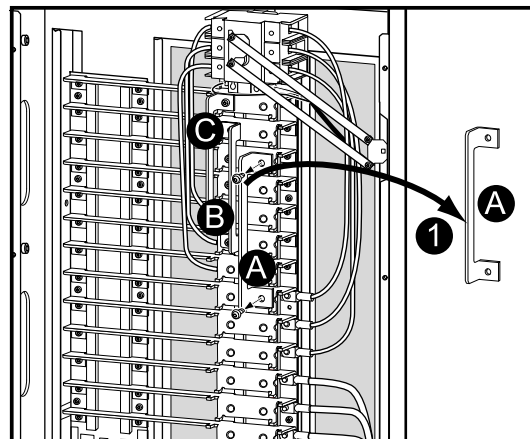

2. Connect the AC input cables and the neutral to the input cable landings.
3. Connect the bypass cables and the neutral to the bypass cable landings.
4. Connect the output cables and the neutral to the output cable landings.
5. Connect the ground cables to the studs (earth symbol beneath) using a screw.

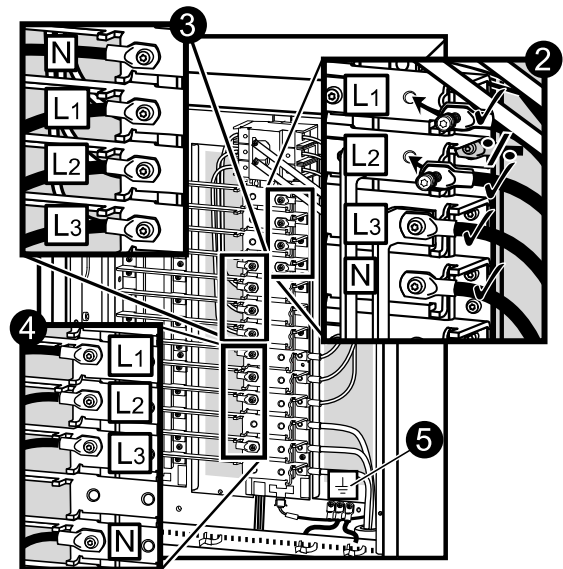

Connect the DC Battery Cables (if applicable)

1. Connect battery cables BAT+, BAT-, and N to the battery cable landings. Bundle the cables using the supplied cable ties.

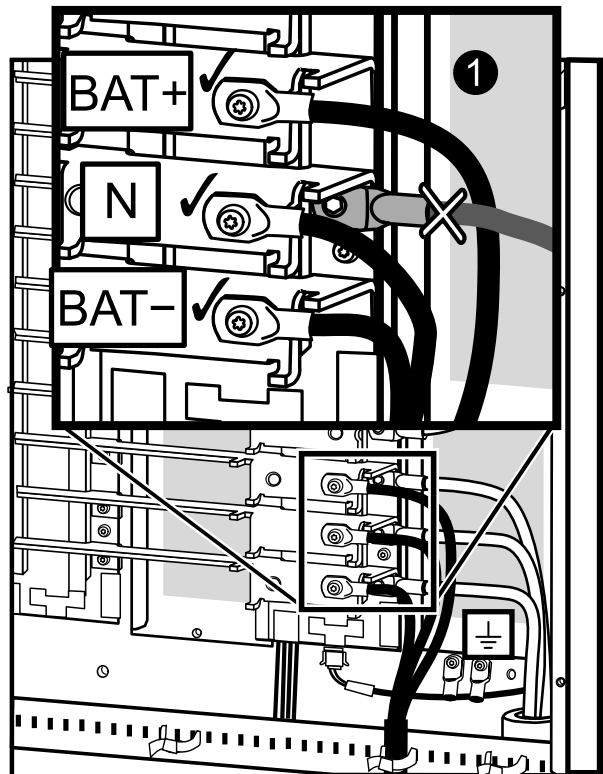

Connect the Communication Cables

Prepare for Communication Cables



WARNING: Make sure that the UPS is completely OFF as the connectors are very close to the power busbars.



WARNING: Before connecting the communication cables, place the two supplied ferrites over the communication cables. Run the cable three times through the ferrite to reduce noise.

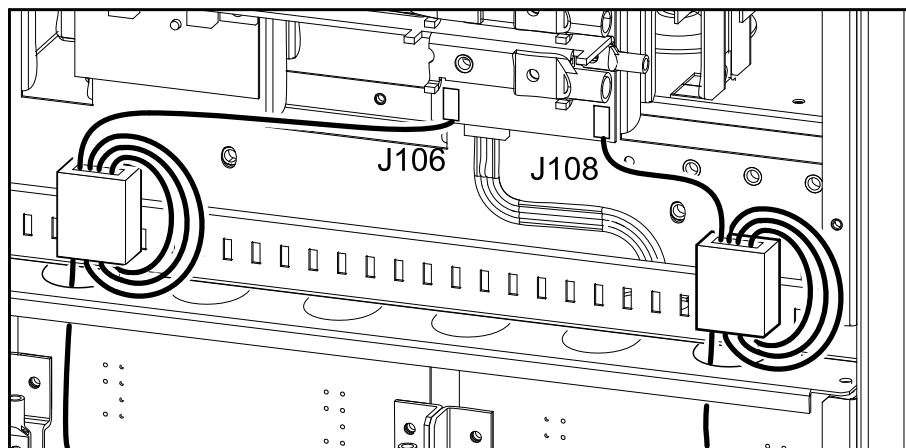

Overview of Pin Connections

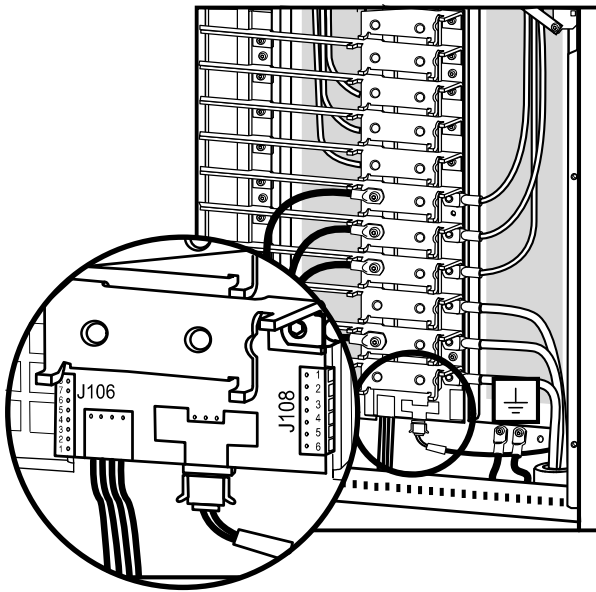

J108 pin connections:

- 1: Normally open EPO
- 2: Normally open EPO return
- 3: Normally closed EPO
- 4: Normally closed EPO return
- 5: +24 V SELV supply
- 6: SELV ground

J106 pin connections:

- 8: Ext. charging control return
- 7: External control of charging
- 6: Q3 active return
- 5: Q3 active
- 4: Battery measurement supply*
- 3: Battery unit quantity*
- 2: Max. battery temperature*
- 1: Battery measurement return*

* Should be used with APC XR Battery Enclosures

J106

Pins 1 to 4 are for battery measurement (only applicable to MGE Galaxy 3500 XR Battery Enclosures).

Pins 5 and 6 are for external maintenance bypass Q3 (auxiliary switch N/C type). When Q3 is closed, signals are fed back to the UPS controller.

Pins 7 and 8 are for external charge control. When 7 and 8 are closed, the UPS charges batteries with a pre-defined percentage (0–25–50–75–100%) of the maximum charging power. To be used in generator applications, or if special codes require control of charging. When Q3 is closed, signals are fed back to the UPS controller.

EPO in Single Systems

Connect the EPO cable using one of the following four wiring configurations.



Note: Use only 1-1½ mm² copper wire for the connection of the Emergency Power Off (EPO) and other optional equipment.



Note: The UPS must be connected to either a dry contact or a 24 VDC EPO (Emergency Power Off) switch.



Note: The external EPO +24 VDC, 1500 mA circuit can be supplied through other vendors.

1. **Dry Contacts Normally Open:** EPO is activated when pin 1 is connected to pins 3 and 5. Connections: 2-4-6, 3-5, and 1 (Normally Open).

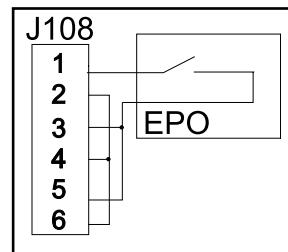

2. **+24 V Normally Open:** EPO is activated when an isolated SELV 24 VDC voltage is supplied on pin 1 with reference to pin 2. Connections: 3-5 and 4-6.

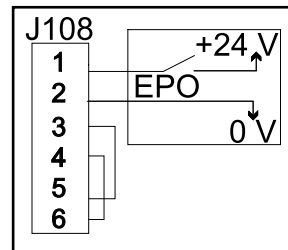

3. **Dry Contacts Normally Closed:** EPO is activated when a connection from pin 3 to 5 is opened. Connections: 4-6.

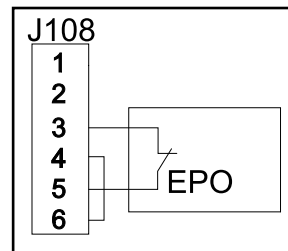

4. **+24 V Normally Closed:** EPO is activated when a SELV 24 VDC voltage is removed from pin 3 with reference to pin 4.

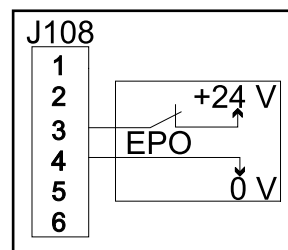

EPO in Parallel Systems

In parallel systems each UPS unit must have its own dry contact (voltage free) connected to J108. The drawing below shows a “Normally Closed” installation of three UPS units in parallel.



WARNING: For parallel and separate systems with common EPO, each UPS unit must be connected to a separate dry contact.



WARNING: Parallel EPO wiring between more UPS units can result in critical UPS malfunctioning.

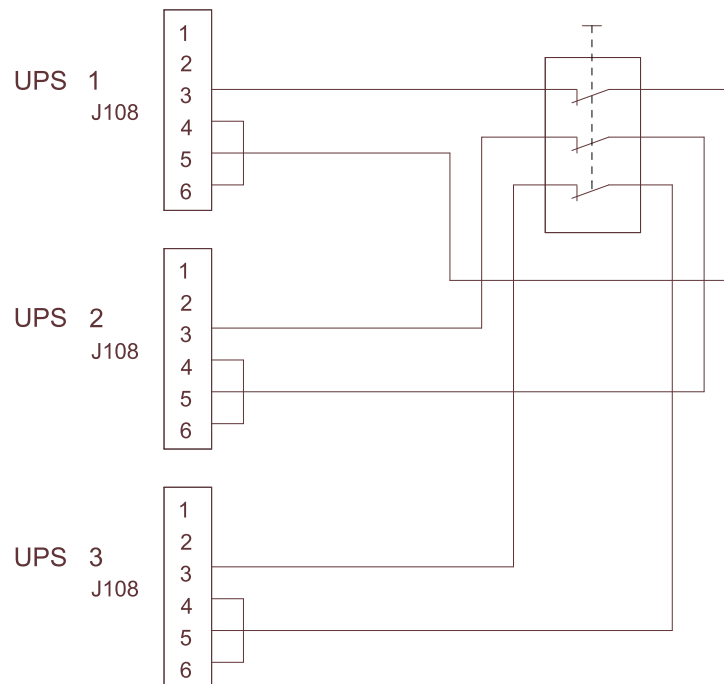

Connect Communication Cables between UPS and XR Battery Enclosure

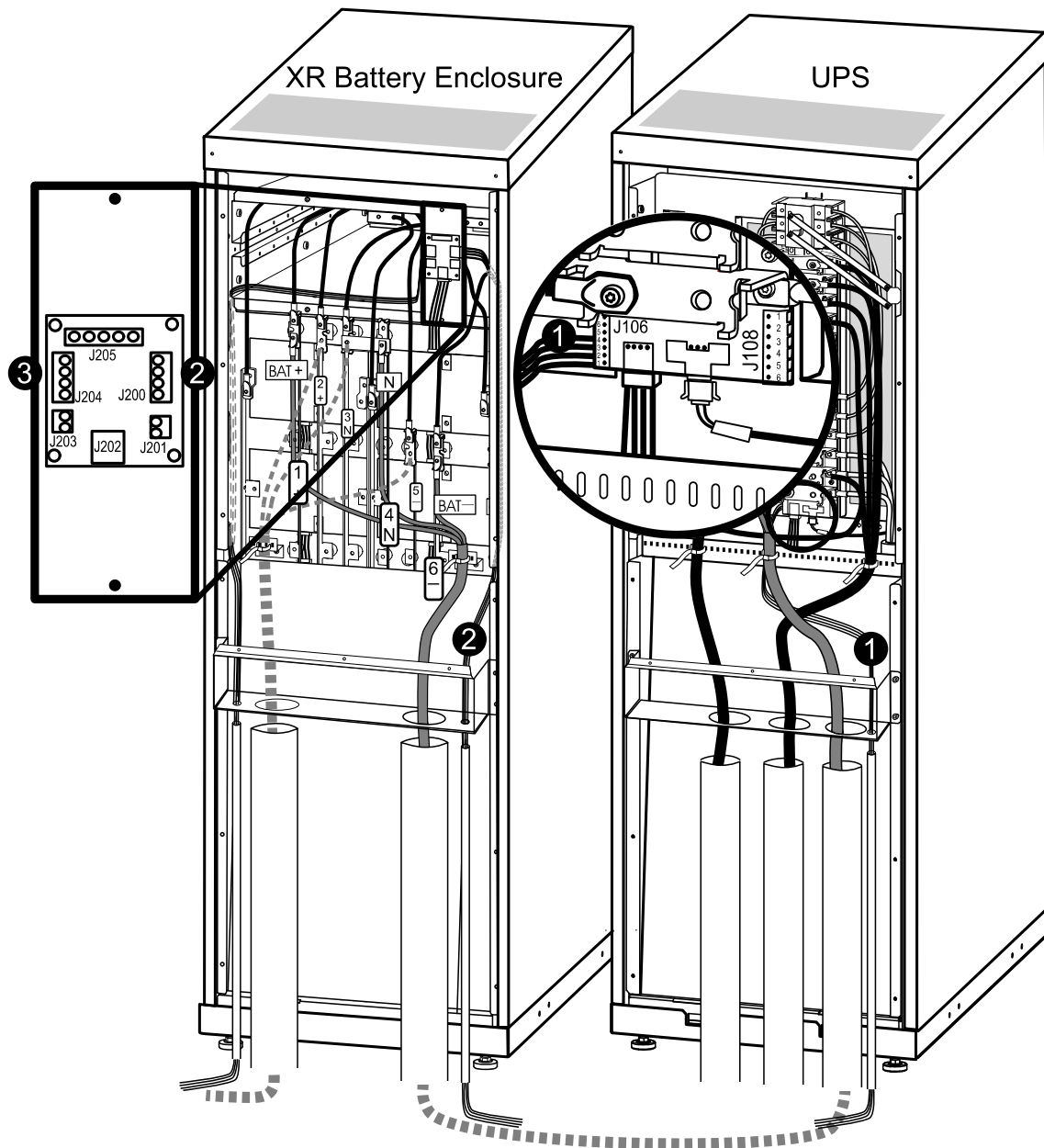

1. Feed the cable from pin connection J106 in the UPS down through the conduit (if applicable).
2. Run the cable up into the XR conduit and connect it to pin connection J200 in the XR Battery Enclosure.
3. If you use a second XR, run the cable from pin connection J204 in XR1 to pin connection J200 in XR2.

Connect APC Communication Options



Note: The cable routing of the power chute software and the temperature sensor is identical.



Note: The temperature sensor is provided in a plastic bag attached to the front of the UPS behind the front panel.

1. Remove the two screws from the cable-inlet at the front and remove the cable-inlet plate.
2. Guide the cable through the hole in the bottom plate and up through the cable-inlet.
3. Guide the cable through the side panel hole and run the cable upwards inside the panel.
4. Pull the cable out of the side panel through the hole closest to the Network Management Card area.
5. Plug the cable into the probe socket / PowerChute inlet.
6. Reattach the cable-inlet plate.

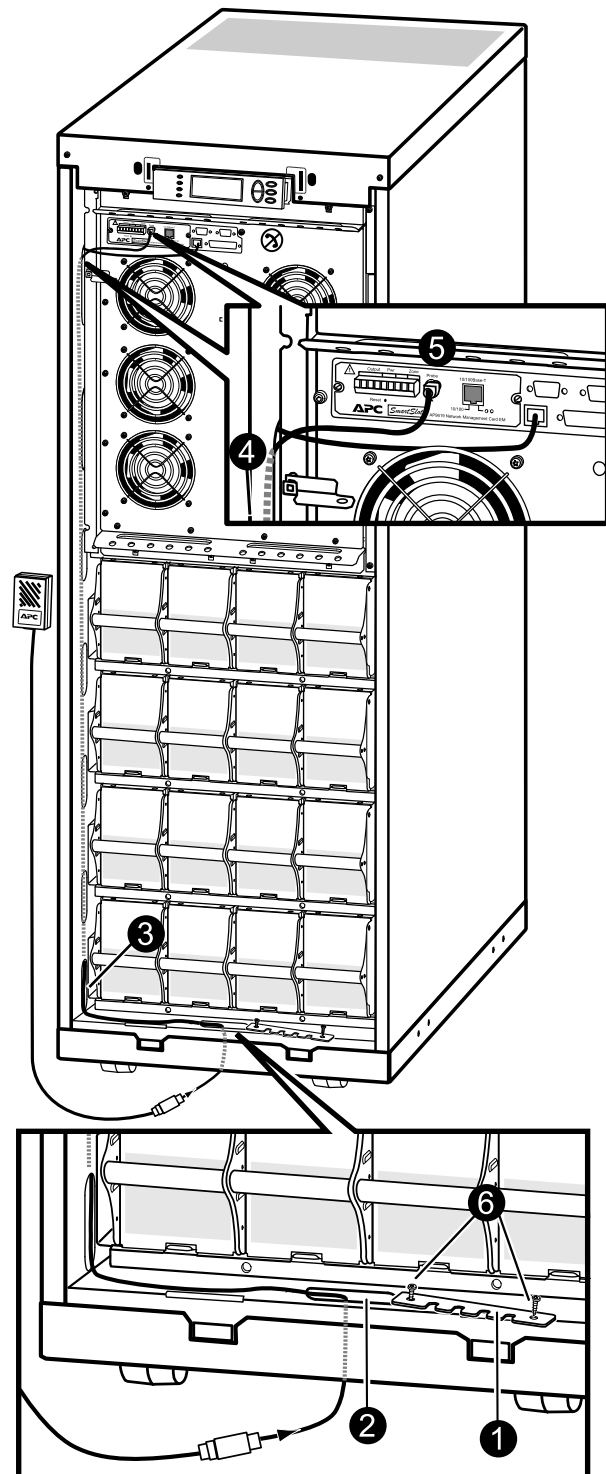

Connect Communication Cables in Parallel System



Note: The cables must be run by the electrician but not attached. The field service engineer from Schneider Electric will attach all cables to the UPS unit(s) and install the parallel communication box. The below is for overview only.



Note: The PBus cables run from UPS 1 to UPS 2 to UPS 3 and UPS 4 if your configuration consists of 4 UPS units.



Note: The PBus cables are labelled PBus 1 and PBus 2.

Overview of the PBus Cables



Note: The cables must be run by the electrician but not attached. The field service engineer from Schneider Electric will attach all cables to the UPS unit(s) and install the parallel communication box. The below is for overview only.



Note: The PBus cables run from UPS 1 to UPS 2 to UPS 3 and UPS 4 if your configuration consists of 4 UPS units.



Note: The PBus cables are labelled PBus 1 and PBus 2.



Note: PBus 1 cables must be kept together, and PBus 2 cables must be kept together. If you by mistake run a cable between a PBUS1 terminal and a PBUS2 terminal, you will be notified by the display.



Note: If the configuration consists of only two UPS units, the terminators must be installed in UPS 1 and 2. With three UPS units, the terminators must be installed in UPS 1 and 3.

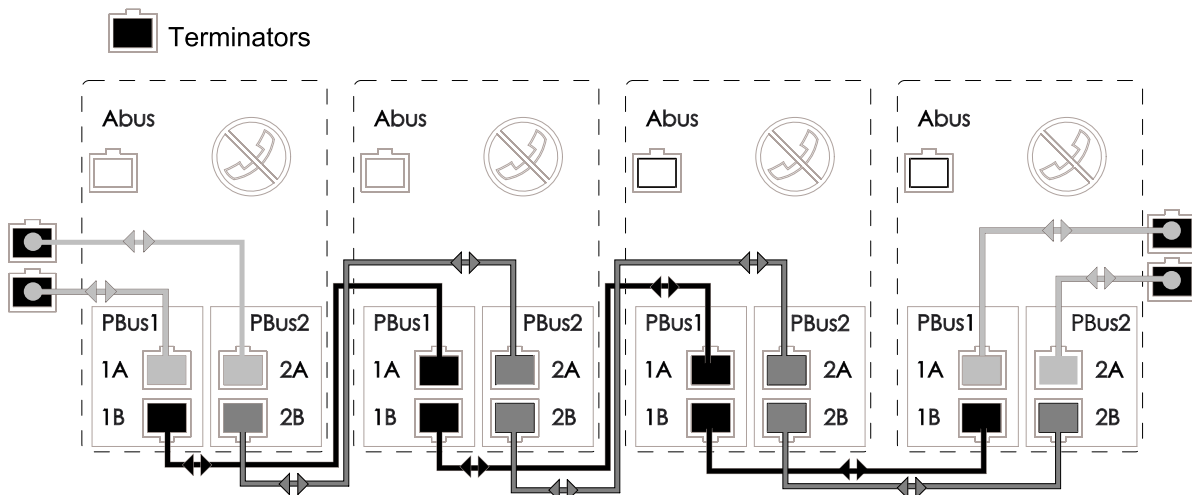

Prepare for Cables

Remove the Batteries



Note: See “*Remove the Battery Modules*“ for information on how to remove the batteries.

Run the Communication Cables

Three different ways of routing cables



Note: The enclosures in a parallel system can be kept apart, or they can be assembled with interconnection plates. If the enclosures are kept apart, the communication cables can be run in conduits (if applicable).

The routing of cables between the UPS units can be done in three different ways.

- UPS units apart (without conduits and without interconnection plates)
- UPS units bayed together (without conduits and with interconnection plates)
- UPS units apart or bayed together (with conduits and optional interconnection plates)

UPS Units Apart without Conduits and Interconnection

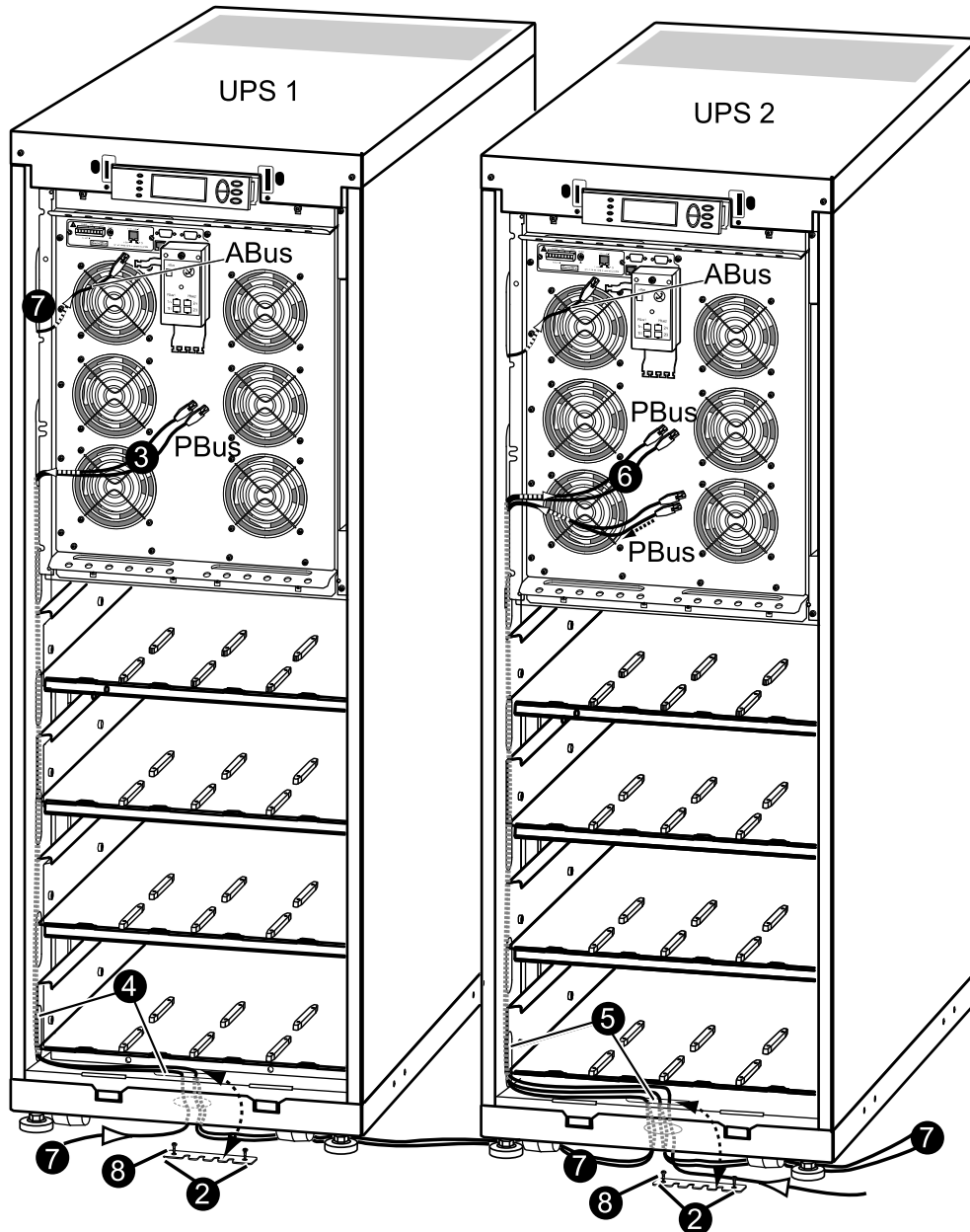

1. Remove the front panel (not shown).
2. Loosen the two screws from the cable-inlet plates at the bottom plate of UPS 1 and UPS 2 and then remove the plates.
3. From UPS 1: Run the two PBus cables to the slots on the left side of the enclosure and down inside the panel.
4. From the lowest slot, fish out the cables from the side panel and run these down through the cable inlet and through the round hole at the bottom.
5. Run the PBus cables to UPS 2 and to the slots on the left side of the enclosure and up inside the panel.
6. Take out the PBus cables and leave these unattached to the parallel box.
7. Run the ABus cable from the maintenance bypass panel to the slots on the left side of the enclosure and up inside the panel the same way as for the PBus cables.
8. Reattach the cable-inlet covers.
9. Fasten the cables with cables ties.



Note: Proceed the routing of cables into UPS 3 and UPS 4, if applicable.

UPS Units Bayed Together without Conduits

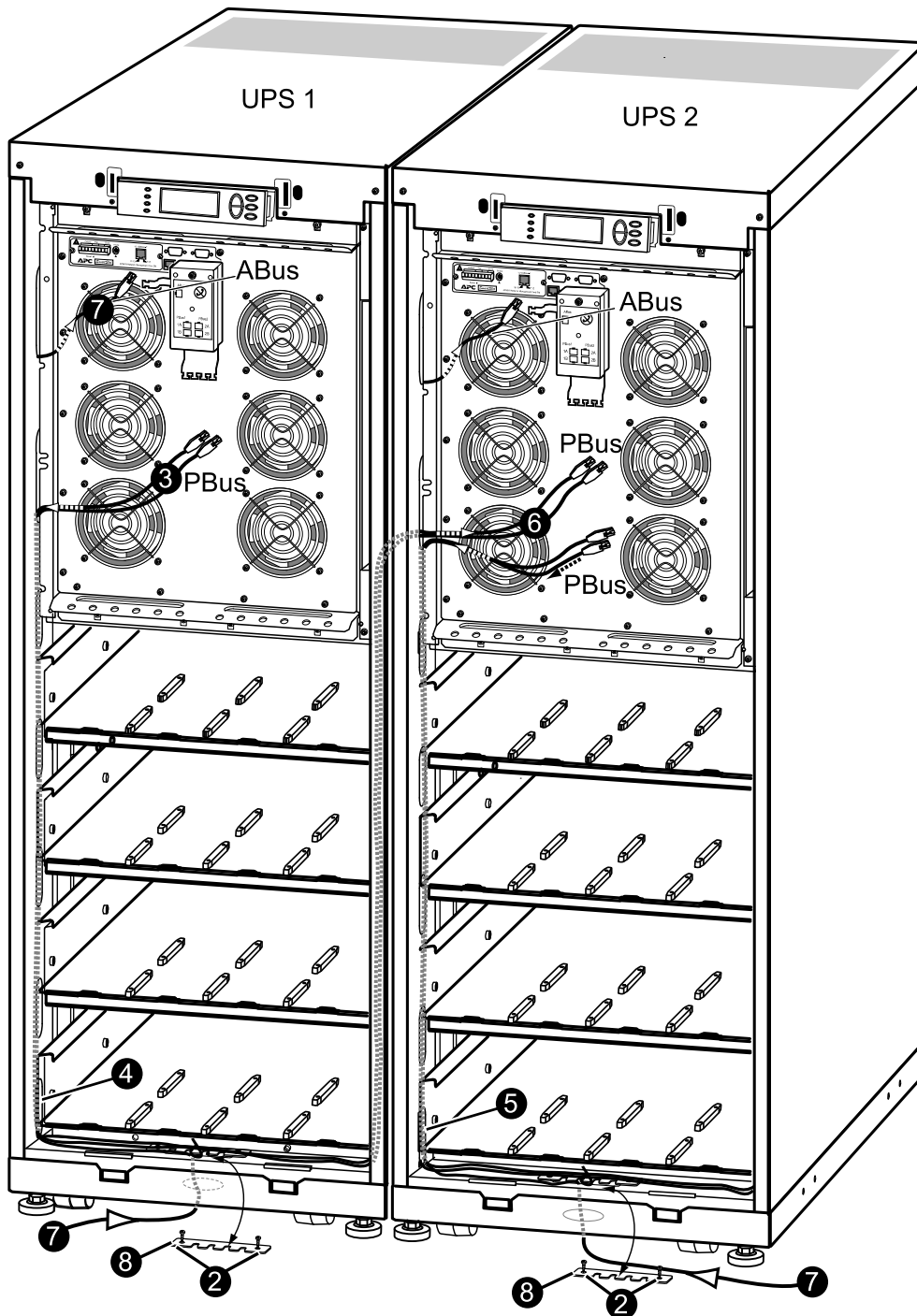

1. Remove the front panel and the top cover (not shown).
2. Loosen the two screws from the cable-inlet plates at the bottom plate of UPS 1 and UPS 2 and then remove the plates.
3. From UPS 1: Run the two PBus cables to the slots on the left side of the enclosure and down inside the panel.
4. From the lowest slot, take out the cables from the side panel, run the cables across and through the cable inlets of the two side panels.

5. From the bottom of UPS 2, run the PBus cables to the slots on the left side of the enclosure and up inside the panel.
6. Take out the PBus cables and leave these unattached.
7. Run the ABus cable from the maintenance bypass panel to the slots on the left side of the enclosure and up inside the panel the same way as for the PBus cables.
8. Reattach the cable-inlet cover plates.
9. Fasten the cables with cable ties.



Note: Proceed the routing of cables into UPS 3 and UPS 4, if applicable.

UPS Units Apart or Bayed Together with Conduits



Note: When enclosures are assembled with interconnection plates and bolted together, the PBus cables can be run inside the enclosures and then only the ABus cable has to be run in a conduit (if applicable).

1. Remove the front panel (not shown).
2. Remove the top cover:
 - A. Loosen the six screws of the top cover (four at the front and two at the back).
 - B. Lift up from the back and push forward to free the cover.
 - C. Leave the cover unattached on top of the UPS.

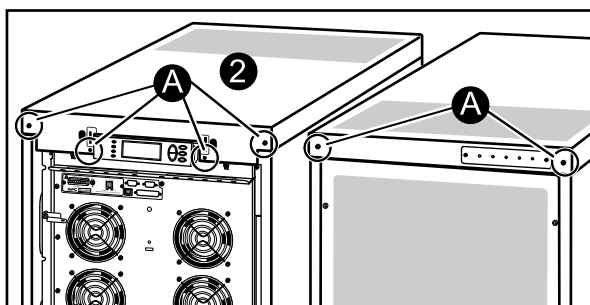

3. Remove the conduit plate at the back of the UPS cover and drill holes centered in the small pre-drilled holes. 2 cm (3/4 in) is recommended for conduits.

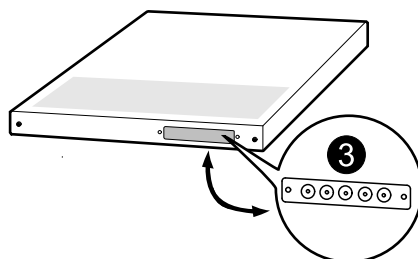

4. Run the ABus and the PBus cables through the conduit holes into the inside of the top cover on UPS 1. Leave the cables on top of the UPS.
5. Attach conduits with 2 cm (3/4 in) fittings (not supplied).
6. Run conduits with PBus cables to UPS 2. Pull the cables through the top cover conduit plate and leave the cables on top of the UPS as shown.
7. Attach conduits to UPS 2 with 2 cm (3/4 in) fittings (not supplied).
8. Run the ABus cables (in conduits if applicable) to the maintenance bypass panel.

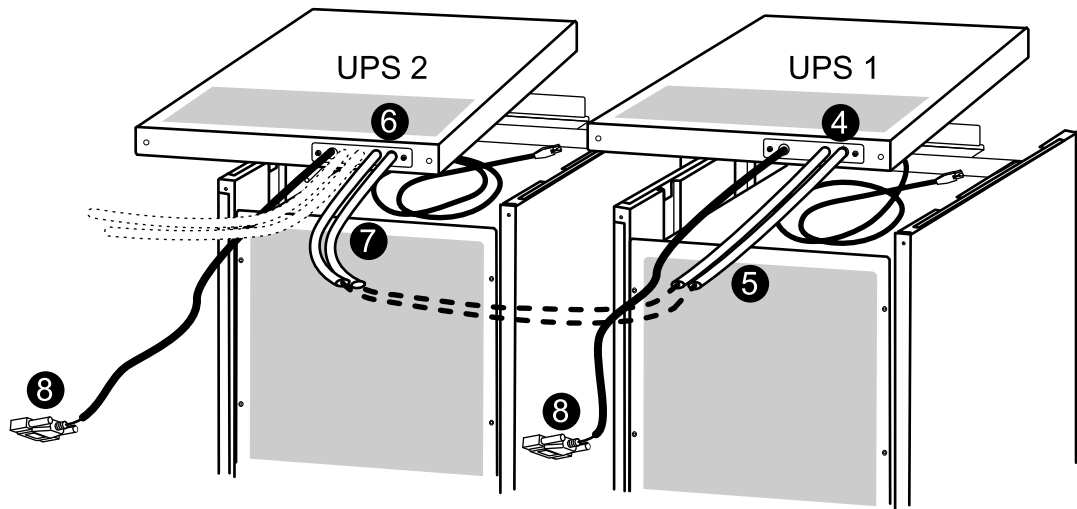

9. Reinstall the top cover.



Note: Proceed the routing of cables into UPS 3 and UPS 4, if applicable.

Install Seismic Option

Install the Seismic Battery Lock



Note: In seismic areas, dispose of the battery securing brackets that were used to secure the batteries during transport and use the seismic battery locks to secure the batteries.

Required parts:

- Four battery locks and 12 M5 screws for narrow battery enclosures.
- Six battery locks and 30 M5 screws for wide battery enclosures.

1. Place the battery lock below the battery row.
2. Secure the battery lock by the provided M5 screws.

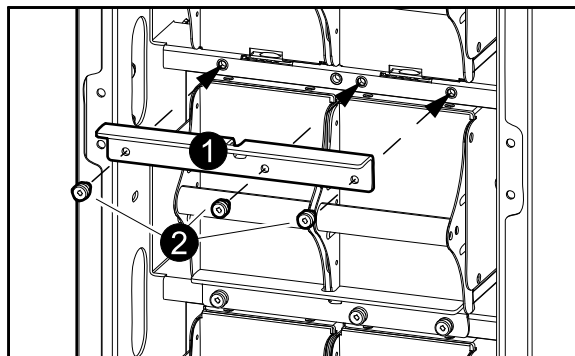
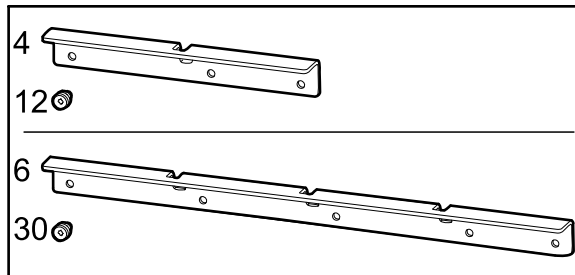

Install the Seismic Stabilizing Brackets

Required parts:

- UPS, Battery Enclosure and Transformer
 - Eight 10 mm fittings
 - 18 M6 nut washers
 - One horizontal bracket
 - Four stabilizing brackets
- Maintenance Bypass Panel (MBP)
 - Eight 2 mm fittings
 - 18 M6 nut washers
 - One horizontal bracket
 - Four stabilizing brackets

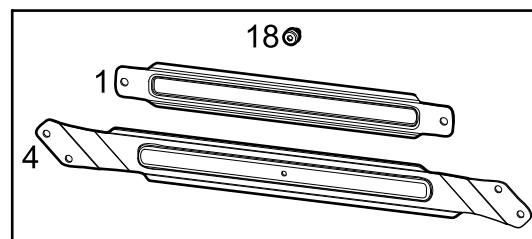
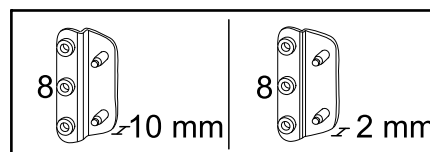



Note: When MBPs and transformer cabinets are installed up against other frames, it is sufficient to install only one cross with a horizontal bracket in top or lower position.

1. Insert pins of the fitting into the indicated mounting holes.
2. Mount the brackets in the fittings and secure.

Front view

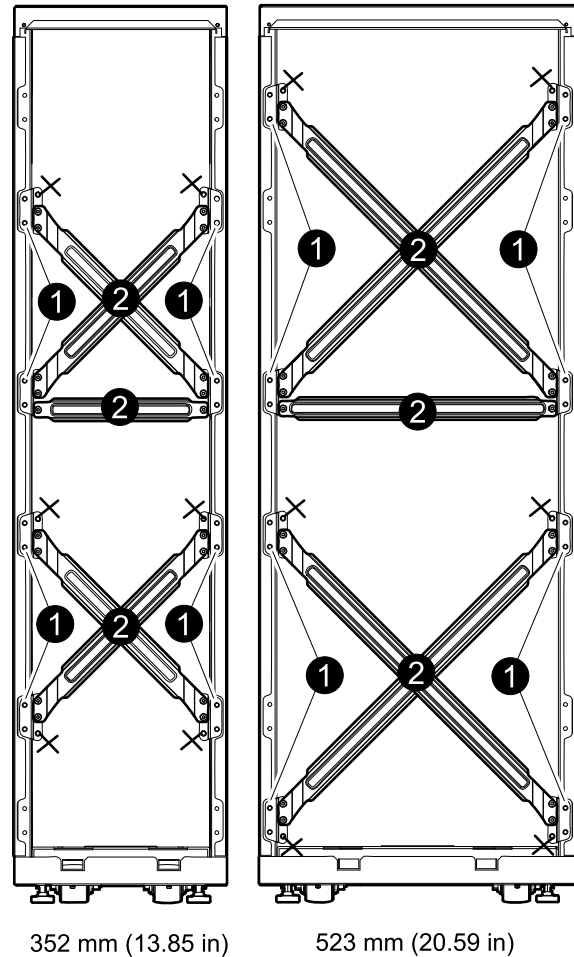

Final Mechanical Installation

Connect Battery Securing Brackets for Stability



Caution: Wait until the system is ready to be powered up before installing batteries. Failure to do so can result in a deep discharge of the batteries and cause permanent damage (the time from the battery installation time till the UPS is powered up should not exceed 72 hours or 3 days).



Note: The battery securing brackets are only used in non-seismic areas for stability, and when seismic battery locks are not part of the installation.

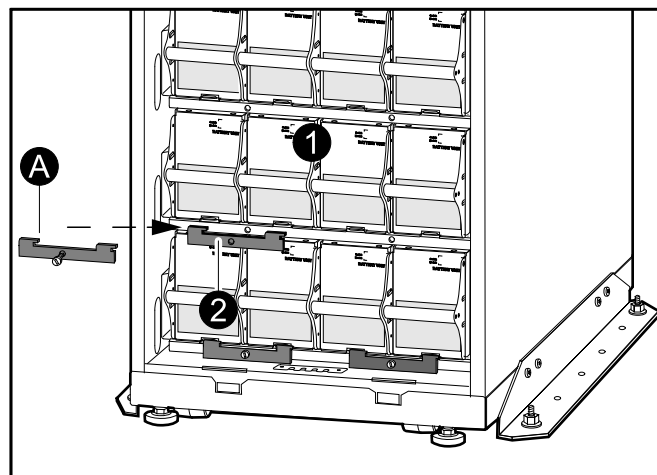

1. Install the batteries by pushing them all the way into the enclosure.
2. If required, install the battery securing brackets (A) to hold the batteries firmly in place. **NOTE:** Do not install the brackets the same way they were positioned when the enclosure arrived. Rotate the brackets 180° and reinstall.



Note: Battery securing brackets are delivered with the UPS and XR Battery Enclosure and installed in front of the batteries. Battery securing brackets for additional batteries can be purchased. Refer to option SUVTOPT003: APC Smart-UPS VT Battery Lock Kit for one Battery Module (two batteries).

Reinstall the Top Cover and the Front Panel

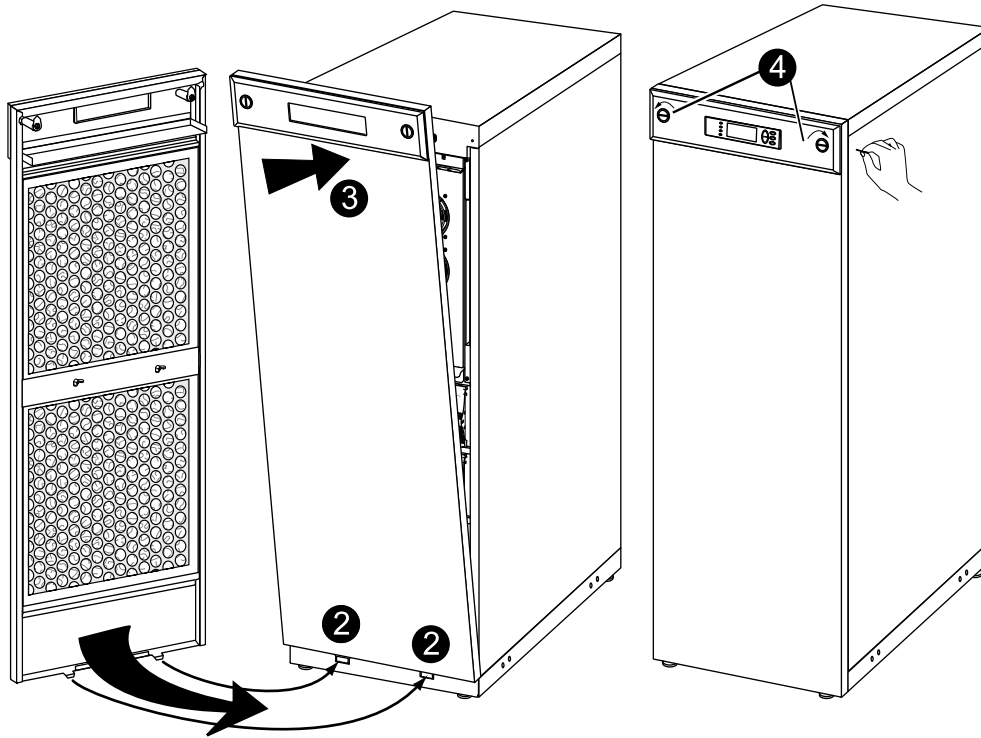

1. Reinstall the top cover by fastening the four screws at the front and the two screws at the back.
2. Insert the two tabs at the bottom of the front panel into the two slots at the bottom of the enclosure.
3. Push the front panel forward until it engages the locking devices at the top of the enclosure.
4. Use a screwdriver to set the lock mechanism to the locked position.

Worldwide Customer Support

Customer support is available at no charge via e-mail or telephone. Contact information is available at www.apc.com/support/contact

© APC by Schneider Electric. APC and the APC logo are owned by Schneider Electric Industries S.A.S., American Power Conversion Corporation, or their affiliated companies. All other trademarks are property of their respective owners.

Free Manuals Download Website

<http://myh66.com>

<http://usermanuals.us>

<http://www.somanuals.com>

<http://www.4manuals.cc>

<http://www.manual-lib.com>

<http://www.404manual.com>

<http://www.luxmanual.com>

<http://aubethermostatmanual.com>

Golf course search by state

<http://golfingnear.com>

Email search by domain

<http://emailbydomain.com>

Auto manuals search

<http://auto.somanuals.com>

TV manuals search

<http://tv.somanuals.com>