



**User Manual**

**English**

**APC Smart-UPS®**

**1500/3000 VA 120/230 Vac**

**Modular  
Uninterruptible Power Supply**

990-1704 01/2004



## Introduction

This APC Smart-UPS is a modular Uninterruptible Power Supply (UPS) for high availability applications such as data centers and mission critical processes, designed to prevent blackouts, brownouts, sags, and surges from reaching your equipment. The UPS filters small utility line fluctuations and isolates your equipment from large disturbances by internally disconnecting from the utility line. The UPS provides continuous power from its internal battery until the utility line returns to safe levels or the battery is fully discharged.

## 1: INSTALLATION

The User Manual and Safety Guide are accessible on the supplied User Manuals CD and on the APC web site, [www.apc.com](http://www.apc.com).

### Unpack

**Attention: Read the safety instruction sheet before installation.**

Inspect the UPS upon receipt. Notify the carrier and dealer if there is damage.

The packaging is recyclable; save it for reuse or dispose of it properly.

Check the package contents:

- UPS
- Bezel
- Tower conversion top panels and mounting stabilizers
- Rail kit
- UPS literature kit containing:
  - Product documentation, safety, and warranty information
  - Smart-UPS User Manuals CD
  - PowerChute<sup>®</sup> CD
  - Network Management Card CD
  - Mounting hardware
  - Serial and USB communication cables
- 230 V models only:*
  - Two input power cords
  - Four output jumper cords

### Position the UPS in the Specified Environment

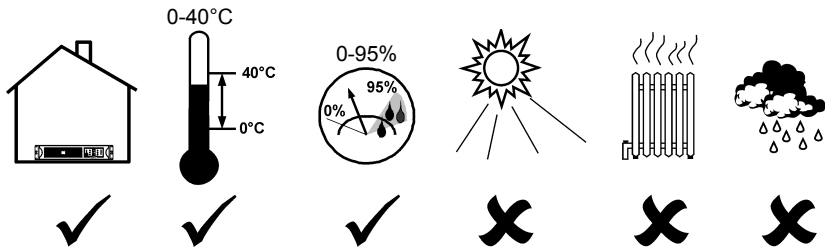

## Mount the UPS in the Rack and Connect the Battery

Attention: Install the rails following the instructions in the rail kit.

1

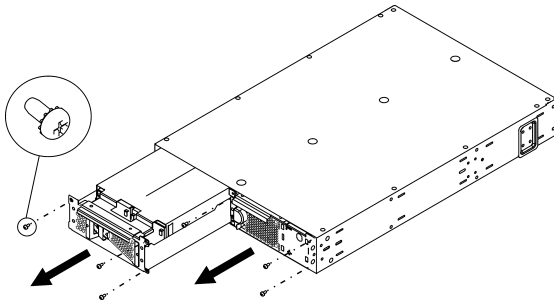

2

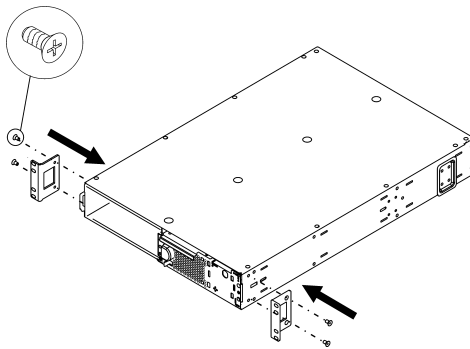

3

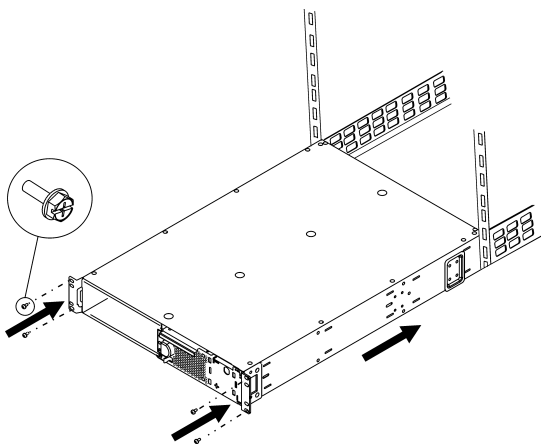

4

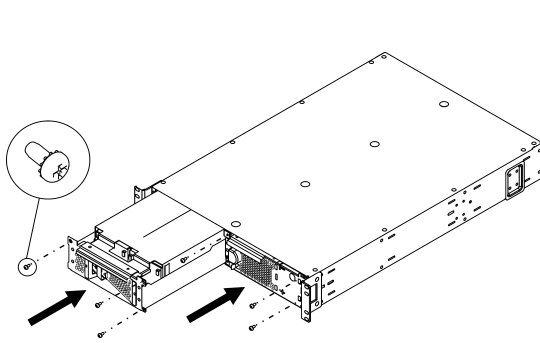

5

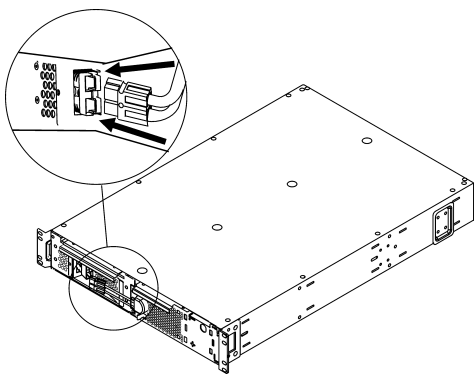

6

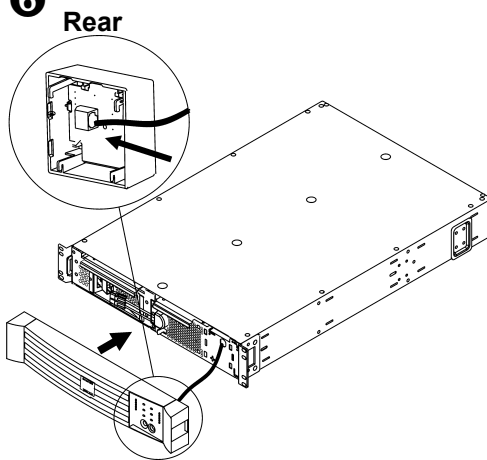

## Tower Configuration

**1** Press and hold the black switch (see location designation on UPS) to the right while removing the power processing module.

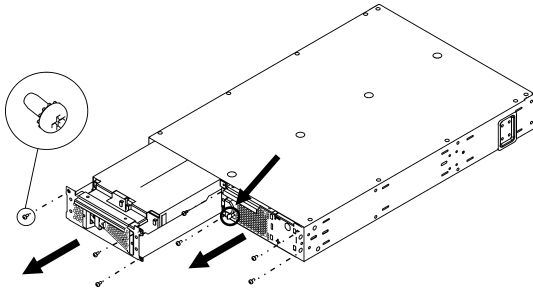

**2**

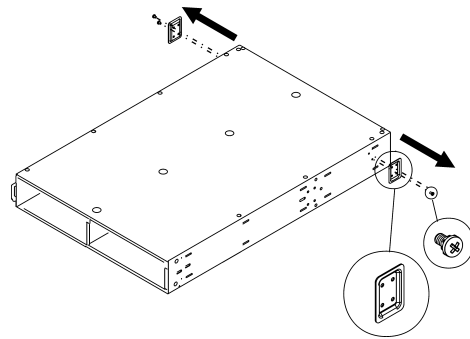

**3**

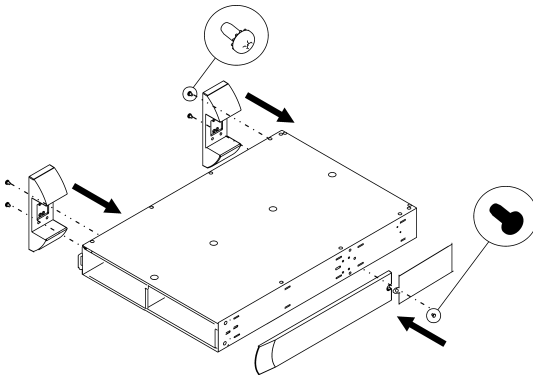

**4** Note: Place the UPS in the final operating location prior to module reinstallation.

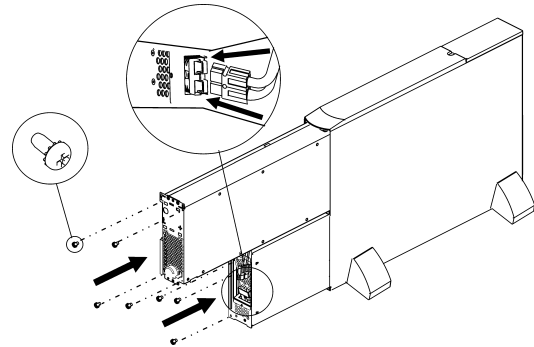

**5** Snap the display bezel out the rear to begin rotation.

**6**

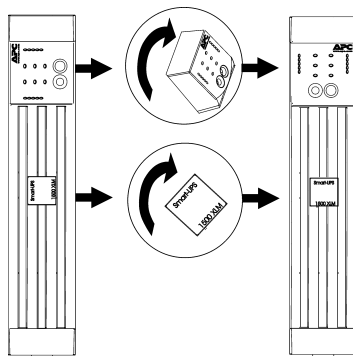

Rear

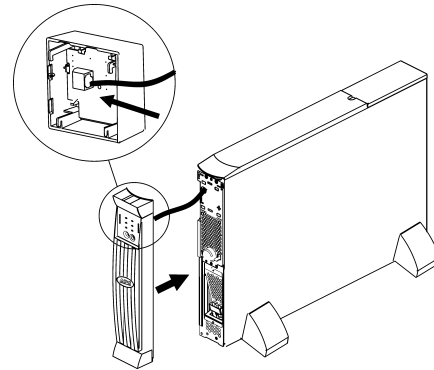

## 2: START UP

### Connect Equipment to the UPS

#### Rear Panels

1500 VA, 120 V:

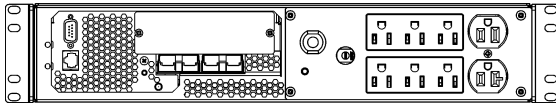

1500 VA, 230 V:

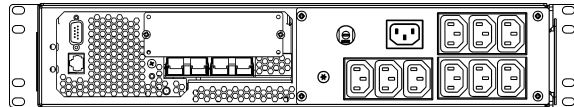

3000 VA, 120 V:

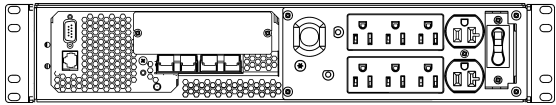

3000 VA, 230 V:

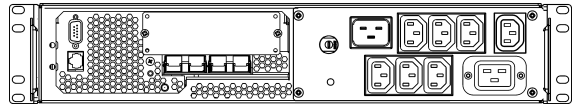

Note:

- The 'outlet groups' can be controlled through the network software. See *Network Management Card* documentation.
- A laser printer draws significantly more power than other types of equipment and may overload the UPS.

### Connect the UPS to the Network (if Applicable)

#### Network Connectors

Serial Port

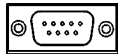

USB Port



Ethernet Port



Note:

- Use only the supplied cable to connect to the Serial Port. A standard serial interface cable is incompatible with the UPS. **Serial and USB ports cannot be used simultaneously.**
- If an optional Smart-Slot accessory is to be used, remove the preinstalled network management card and install it now.

### Start the UPS

**Attention: Upon utility power connection, the UPS will automatically turn on.**

1. Plug the UPS into a two-pole, three-wire, grounded receptacle only.

Input Plugs:

1500 VA models: 120 V = NEMA 5-15P; 230 V = Use country specific 10 A with C14 input cords (not supplied).

3000 VA models: 120 V = NEMA L5-30P; 230 V = Use the supplied cords or the country specific equivalent.

The battery will charge to full capacity during the first few hours of normal operation. Do not expect full 'on battery' capability during this initial charge period.

2. After the UPS has ended the immediate self-test with *online* LED illumination, check the front display for any fault indicators (see *Troubleshooting*).
3. *120 V models*: Check the *site wiring fault* LED located on the rear panel. It will be illuminated if the UPS is plugged into an improperly wired utility power outlet (see *Troubleshooting*).
4. Turn on all connected equipment. To use the UPS as a master on/off switch, be sure all connected equipment is on.

Equipment is now powered and protected. Basic operation, user configuration, and software utilization can now be performed as required.

### **Battery Operation**

The UPS switches to battery operation automatically if the utility power fails. While running on battery, an alarm beeps four times every 30 seconds. Press the  button to silence this alarm.

If the utility power does not return, the UPS continues to supply power to the connected equipment until the battery is fully discharged.

Refer to [www.apc.com](http://www.apc.com) for battery runtime charts.

When the UPS reaches the low battery shutdown warning (two minute default), the alarm will beep continuously until total shutdown. Connected equipment should be shut down during this time, unless being controlled by network monitoring software.



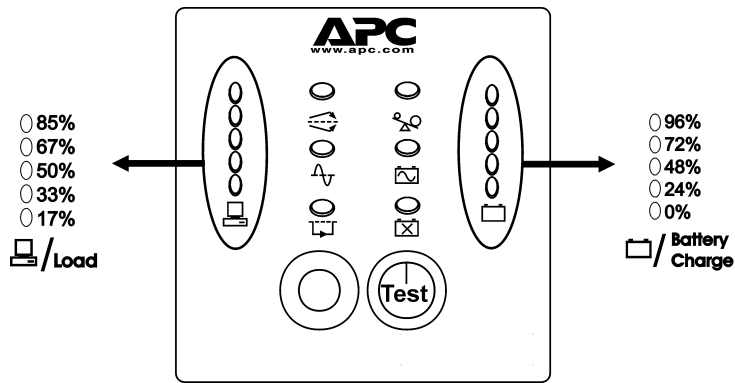

### 3: BASIC OPERATION

#### Front Display Panel



INDICATOR	DESCRIPTION
Online 	The UPS is supplying utility power to the connected equipment.
AVR 	The UPS is compensating for either a high or low utility voltage.
On Battery 	The UPS is supplying battery power to the connected equipment.
Overload 	The connected loads are drawing more than the UPS power rating.
Bypass 	The connected loads are being powered directly by the utility power connection and not through the power processing module. This is a fault condition, which may be caused by an overload or a failure within the module (see <i>Troubleshooting</i> ).
Replace Battery/ Battery Disconnected 	The battery is disconnected or must be replaced.
FEATURE	FUNCTION
Power Off 	Press this button to turn off the UPS.



FEATURE	FUNCTION												
Self-Test	<p><b>Automatic:</b> The UPS performs a self-test automatically when turned on, and every two weeks thereafter (by default). During the self-test, the UPS briefly operates the connected equipment on battery.</p> <p><b>Manual:</b> Press and hold the  button for a few seconds to initiate the self-test.</p>												
Cold Start	<p>Supply battery power to the UPS and connected equipment in the absence of utility voltage (see <i>Troubleshooting</i>). Press the  button for one second and release. The UPS will beep briefly and go quiet. Press and hold the button again, but for approximately three seconds. The unit will emit a sustained beep. Release the button during this beep.</p>												
<p>Diagnostic Utility Voltage</p> <table data-bbox="365 596 544 766"> <tr> <td><b>120V</b></td> <td><b>230V</b></td> </tr> <tr> <td>0 138</td> <td>0 266</td> </tr> <tr> <td>0 129</td> <td>0 248</td> </tr> <tr> <td>0 119</td> <td>0 229</td> </tr> <tr> <td>0 110</td> <td>0 210</td> </tr> <tr> <td>0 101</td> <td>0 192</td> </tr> </table> <p>Battery Charge </p>	<b>120V</b>	<b>230V</b>	0 138	0 266	0 129	0 248	0 119	0 229	0 110	0 210	0 101	0 192	<p>The UPS has a diagnostic feature that displays the utility voltage.</p> <p><b>The UPS starts a self-test as part of this procedure. The self-test does not affect the voltage display.</b></p> <p>Press and hold the  button to view the utility voltage bar graph display. After a few seconds, this five-LED <i>battery charge</i>  display on the right of the front panel will show the utility input voltage. Refer to the figure at left for the voltage reading (values are not listed on the UPS).</p> <p>The display indicates the voltage is between the displayed value on the list and the next higher value (see <i>Troubleshooting</i>).</p>
<b>120V</b>	<b>230V</b>												
0 138	0 266												
0 129	0 248												
0 119	0 229												
0 110	0 210												
0 101	0 192												

## 4: USER CONFIGURABLE ITEMS

<b>NOTE: SETTINGS ARE MADE THROUGH THE SUPPLIED POWERCHUTE SOFTWARE OR THE NETWORK INTERFACE CONNECTION. REFER TO THE SOFTWARE HELP GUIDES FOR DETAILS.</b>			
<i>FUNCTION</i>	<i>FACTORY DEFAULT</i>	<i>USER SELECTABLE CHOICES</i>	<i>DESCRIPTION</i>
Automatic Self-Test	Every 14 days (336 hours)	Every 14 days (336 hours), Every 7 days (168 hours), On Startup Only, No Self-Test	This function sets the interval at which the UPS will execute a self-test.
UPS ID	UPS_IDEN	Up to eight characters	Use this field to uniquely identify the UPS, (i.e. server name or location) for network management purposes.
Date of Last Battery Replacement	Manufacture Date	mm/dd/yy	Reset this date when you replace the internal battery module.
Minimum Capacity Before Return from Shutdown	0 percent	0, 15, 30, 45, 60, 75, 90 percent	The UPS will charge its batteries to the specified percentage before powering up connected equipment, following a low-battery shutdown.
Voltage Sensitivity	High	High, Medium, Low	The UPS detects and reacts to line voltage distortions by transferring to battery power to protect the connected equipment. When power quality is poor, the UPS may frequently transfer to battery power. If the connected equipment can operate normally under such line voltage conditions, reduce the sensitivity setting to conserve battery's capacity and service life.
Alarm Control	Enable	Enable, Mute, Disable	User can mute an ongoing alarm or disable all existing alarms permanently.
Shutdown Delay	90 seconds	90, 180, 270, 360, 450, 540, 630, 0 seconds	The interval is set between the times when the UPS receives a shutdown command and when it shuts off power to the outlets.
Low Battery Warning	2 minutes	2, 5, 8, 11, 14, 17, 20, 23 minutes	PowerChute software provides automatic, unattended shutdown when the remaining battery runtime matches this setting while on battery.  Change the low battery warning interval default setting to the time that the operating system or system software requires to safely shut down.
Synchronized Turn-on Delay	0 seconds	0, 60, 120, 180, 240, 300, 360, 420 seconds	The UPS will wait the specified time after the return of utility power before turn-on (to avoid branch circuit overload).

<b>NOTE: SETTINGS ARE MADE THROUGH THE SUPPLIED POWERCHUTE SOFTWARE OR THE NETWORK INTERFACE CONNECTION. REFER TO THE SOFTWARE HELP GUIDES FOR DETAILS.</b>			
<b>FUNCTION</b>	<b>FACTORY DEFAULT</b>	<b>USER SELECTABLE CHOICES</b>	<b>DESCRIPTION</b>
High Transfer Point	120 V: 127 VAC  230 V: 253 VAC	120 V: 127, 130, 133, 136 VAC  230V: 253, 257, 261, 265 VAC	If the utility voltage is usually high and the connected equipment is specified to operate with input voltages this high, set the high transfer point higher to avoid unnecessary battery usage.
Low Transfer Point	120 V: 106 VAC  230 V: 208 VAC	120 V: 106, 103, 100, 97 VAC  230 V: 208, 204, 200, 196 VAC	If the utility voltage is usually low and the connected equipment is specified to operate with input voltages this low, set the low transfer point lower.

## 5: STORAGE, MAINTENANCE, SHIPPING, AND SERVICE

### Storage

Store the UPS covered in a cool, dry location, with the battery fully charged.

At -15 to +30 °C (+5 to +86 °F), charge the UPS battery every six months.

At +30 to +45 °C (+86 to +113 °F), charge the UPS battery every three months.

### Battery Module Maintenance

The UPS battery life differs based on usage and environment. Consider replacing the battery every three years.

This UPS has an easy to replace, hot-swappable battery. Replacement is a safe procedure, isolated from electrical hazards. You may leave the UPS and connected equipment on during the replacement procedure.

**Note: Upon battery disconnection, equipment is not protected from power outages.**

See your dealer or contact APC (see *Contact Information*) for information on replacement batteries.

Refer to *Rack-Mount the UPS and Connect the Battery* for instructions on battery removal and replacement.

### Power Processing Module Replacement

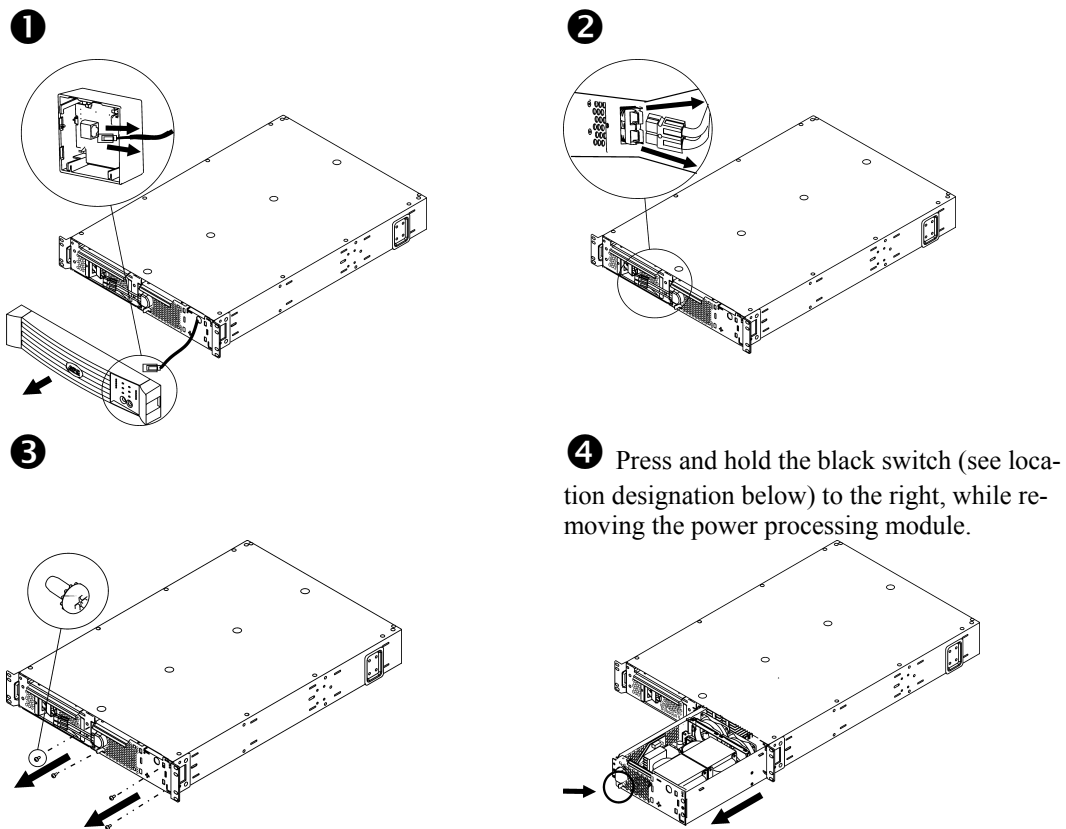

\*Reverse steps 1-4 for installation of the new module.

## Shipping

1. Shut down and disconnect any equipment attached to the UPS.
2. Shut down the UPS, and disconnect the UPS from the utility power outlet.
3. Unplug the battery connector.

For further shipping instructions and to obtain appropriate packing materials, contact APC (see *Contact Information*).

## Service

If the UPS requires service do not return it to the dealer. Follow these steps:

1. Review the problems discussed in *Troubleshooting* to eliminate common problems.
2. If the problem persists, contact APC Customer Service through the APC web site, [www.apc.com/support](http://www.apc.com/support).
  - Note the model number of the UPS, the serial number, and the date purchased. If you call APC Customer Service, a technician will ask you to describe the problem and attempt to solve it over the phone. If this is not possible, the technician will issue a Returned Material Authorization Number (RMA#).
  - If the UPS is under warranty, repairs are free.
3. Pack the UPS in its original packaging. If this is not available, refer to [www.apc.com/support](http://www.apc.com/support) for information about obtaining a new set.
  - Pack the UPS properly to avoid damage in transit. Never use Styrofoam beads for packaging. Damage sustained in transit is not covered under warranty.
  - **Always DISCONNECT THE BATTERY before shipping in compliance with U.S. Department of Transportation (DOT) regulations.** The battery module(s) may remain in the UPS; it does not have to be removed.
4. Mark the RMA# on the outside of the package.
5. Return the UPS by insured, prepaid carrier to the address given to you by Customer Service.

## Contact Information

U.S. Customers - Refer to [www.apc.com/support](http://www.apc.com/support).

International Customers - Refer to [www.apc.com](http://www.apc.com), select the appropriate country from the country selection field, and select the *Support* tab at the top of the web page.

## 6: TROUBLESHOOTING



Use the chart below to solve minor UPS installation and operation problems. Refer to APC for assistance with complex UPS problems.

PROBLEM AND/OR POSSIBLE CAUSE	SOLUTION
<b>UPS WILL NOT TURN ON</b>	
UPS not connected to utility power supply.	Check that the power cord from the UPS to the utility power supply is securely connected at both ends.
Battery not connected properly.	Check that the battery connector is fully snapped into position.
Very low or no utility voltage.	Check the utility power supply to the UPS by plugging in a table lamp. If the light is very dim, have the utility voltage checked.
<b>UPS WILL NOT TURN OFF</b>	
The front display is not lit, yet the outlets are powered.  The black switch is stuck in the off ( <i>right</i> ) position. In this position, the switch disables operation of the power module and power to the loads is bypassed around the power module.	Gently attempt to reposition the black switch to the <i>left</i> , and the module will be activated.
<b>UPS BEEPS OCCASIONALLY</b>	
Normal operating UPS beeps when running on battery.	None. The UPS is protecting the connected equipment from occasional utility power irregularities.
<b>UPS IS NOT PROVIDING EXPECTED BACKUP TIME</b>	
The UPS battery is weak due to a recent outage or is near the end of the service life.	Charge the battery. Batteries require recharging after extended outages, and wear faster when frequently put into service or when operated at elevated temperatures. If the battery is near the end of the service life, consider replacing the battery even if the <i>replace battery</i> LED is not yet illuminated.
<b>THE OUTPUT VOLTAGE IS NOT MEETING EXPECTATIONS</b>	
The output voltage <i>on battery</i> is too low or too high.	Check that the voltage selection rotary switch is set to the desired level (See <i>Installation</i> ). <i>Note: In order to register any modification in voltage selection, the UPS must be turned off and then on again.</i>
The output voltage <i>online</i> is too high or too low.	The UPS allows a certain range of output voltage to be filtered from the input before it goes to battery. If this range is too wide for the load equipment, the upper and lower limits can be customized (through software) to your application.

PROBLEM AND/OR POSSIBLE CAUSE	SOLUTION
<b>NOT ALL OUTLETS ARE POWERED</b>	
One or more of the outlet groups (labeled '1', '2', and '3') are shut off via the network interface connection.	Access the UPS control panel via the network interface connection and check the status of the outlets. If the settings are not what are expected, change them accordingly and review security settings (password, etc.).
<i>3000 VA, 120 V model only:</i> One or more of the outlet groups are overloaded and the circuit breaker(s) tripped.	The three outlet groups are individually protected by circuit breakers, in some cases lower than the overall limit of the UPS. If any one of these has tripped, reduce the load and/or distribute appropriately among the outlet groups and reset the breaker.
<b>RUNTIME IS SUFFICIENT, BUT THE LOW BATTERY WARNING INTERVAL IS LONGER THAN EXPECTED</b>	
The UPS perceives there are fewer batteries than are connected and provides too much warning time.	Configure the UPS via PowerChute to register the number of external battery packs connected (See <i>User Configurable Items</i> ).
The configured low battery warning interval is longer than necessary or expected.	Configure the UPS via PowerChute to provide an adequate low battery warning interval (See <i>User Configurable Items</i> ).
<b>THE LEDS IN THE BATTERY BAR GRAPH ARE BLINKING TOGETHER</b>	
While <i>online</i> or <i>on battery</i> , the expected remaining runtime is lower than the configured low battery warning interval. <i>Note: The number of blinking LEDs still indicates the relative state of charge of the connected batteries.</i>	If the runtime is too short for a graceful shutdown of the connected equipment, additional battery packs must be connected. If the low battery warning interval is longer than required for a graceful shutdown, configure it appropriately via PowerChute.
The battery runtime meter has fallen out of calibration and needs to be recalibrated.	Program the UPS via PowerChute to conduct a runtime calibration test.
<b>ALL LEDS ARE ILLUMINATED AND THE UPS EMITS A CONSTANT BEEPING</b>	
Internal UPS fault.	Do not attempt to use the UPS. Replace the power processing module (See <i>Storage, Maintenance, Transporting, and Service</i> ).
<b>FRONT PANEL LEDS FLASH SEQUENTIALLY</b>	
The UPS has been shut down remotely through software or network interface connection.	None. The UPS will restart automatically when utility power returns.
<b>ALL LEDS ARE OFF AND THE UPS IS PLUGGED INTO A WALL OUTLET</b>	
The UPS is shut down or the battery is discharged from an extended outage.	None. The UPS will return to normal operation when the power is restored and the battery has a sufficient charge.

PROBLEM AND/OR POSSIBLE CAUSE	SOLUTION
<b>THE OVERLOAD LED IS ILLUMINATED AND THE UPS EMITS A SUSTAINED ALARM TONE</b>	
The UPS is overloaded. The connected equipment is drawing more VA or more Watts than the UPS can sustain.	<p>The connected equipment exceeds the specified "maximum load."</p> <p>The alarm remains on until the overload is removed. Disconnect nonessential equipment from the UPS to eliminate the overload.</p> <p>The UPS continues to supply power as long as it is online and the circuit breaker does not trip; the UPS will not provide power from batteries in the event of a utility voltage interruption.</p> <p>If a continuous overload occurs while the UPS is on battery, the unit turns off output in order to protect the UPS from possible damage.</p> <p>(See Maximum Power and VA Specifications)</p>
The condition persists for a few seconds, stops and then repeats approximately every minute.	Equipment such as laser printers draw a great amount of power in short bursts periodically. For instance, laser printers commonly draw nearly 1000 W of power (varies among different printers) for a few seconds, the draw will then stop, only to resume seconds later. The UPS is then subjected to periodic high power draws, and will be briefly overloaded. If the UPS must power a laser printer, be sure the UPS can meet the maximum draw of the laser printer.
<b>THE REPLACE BATTERY LED IS ILLUMINATED</b>	
<i>Replace battery</i> LED flashes and short beep is emitted every two seconds to indicate the battery is disconnected.	Check that the battery connectors are fully engaged.
Weak battery.	Allow the battery to recharge for 24 hours. Then, perform a self-test. If the problem persists after recharging, replace the battery.
Failure of a battery self-test.	The UPS emits short beeps for one minute and the <i>replace battery</i> LED illuminates. The UPS repeats the alarm every five hours. Perform the self-test procedure after the battery has charged for 24 hours to confirm the <i>replace battery</i> condition. The alarm stops and the LED clears if the battery passes the self-test.
<b>THE SITE WIRING FAULT LED ON THE REAR PANEL IS ILLUMINATED (120 V ONLY)</b>	
The UPS is plugged into an improperly wired utility power outlet.	<p>Wiring faults detected include missing ground, hot-neutral polarity reversal, and overloaded neutral circuit.</p> <p>Contact a qualified electrician to correct the building wiring.</p>
<b>THE INPUT CIRCUIT BREAKER HAS TRIPPED (230 V MODELS AND 1500 VA, 120 V MODELS ONLY)</b>	
The circuit breaker switches off.	Reduce the load on the UPS by unplugging equipment. Reset the breaker.
<b>THE AVR LED IS ILLUMINATED</b>	
Your system is experiencing excessive periods of low or high voltage.	Have qualified service personnel check your facility for electrical problems. If the problem continues, contact the utility company for further assistance.



PROBLEM AND/OR POSSIBLE CAUSE	SOLUTION
<b>THE BYPASS LED IS ILLUMINATED</b>	
The UPS has briefly directed power around the power processing module during a startup sequence.	Nothing. This is a normal behavior of the UPS during startup.
The UPS has directed power around the power processing module because of an internal fault.	Replace the power processing module (See <i>Storage, Maintenance, Transporting, and Service</i> ).
<b>THERE IS NO UTILITY POWER</b>	
There is no utility power and the UPS is off.	<p>Use the Cold Start feature to supply power to the connected equipment from the UPS battery.</p> <p>Press the  button for one second and release. The UPS will beep briefly and go quiet. Press and hold the  button again, but for about three seconds. The unit will emit a sustained beep. Release the button during this beep. This will supply immediate power to the UPS and the connected equipment.</p>
<b>UPS OPERATES ON BATTERY ALTHOUGH NORMAL LINE VOLTAGE EXISTS</b>	
230 V models and 1500VA, 120 V model only: UPS input circuit breaker tripped.	To reduce the load on the UPS, unplug equipment and reset the circuit breaker.
Very high, low, or distorted line voltage.	Move the UPS to a different outlet on a different circuit, as inexpensive fuel powered generators may distort the voltage. Test the input voltage with the utility voltage display (see <i>Operation</i> ). If acceptable to the connected equipment, reduce the UPS sensitivity.
<b>BATTERY CHARGE AND BATTERY LOAD LEDS FLASH SIMULTANEOUSLY</b>	
The internal temperature of the UPS has exceeded the allowable threshold for safe operation.	<p>Check that the room temperature is within the specified limits for operation.</p> <p>Check that the UPS is properly installed, allowing for adequate ventilation.</p> <p>Press the black switch on the front of the power processing module to the right. This will shut down the power processing module, leave the UPS on and in bypass mode, while confirming whether the high temperature is still present.</p>

## 7: REGULATORY AND WARRANTY INFORMATION

### 120V models



**警告使用者：**  
這是甲類的資訊產品，在居住的環境中使用時，可能會造成射頻干擾，在這種情況下，使用者會被要求採取某些適當的對策。

This equipment has been tested and found to comply with the limits for a Class A digital device, pursuant to part 15 of the FCC Rules. These limits are designed to provide reasonable protection against harmful interference when the equipment is operated in a commercial environment. This equipment generates, uses, and can radiate radio frequency energy and, if not installed and used in accordance with the instruction manual, may cause harmful interference to radio communications. Operation of this equipment in a residential area is likely to cause harmful interference in which case the user will be required to correct the interference at his/her own expense.

Shielded signal cables must be used with this product to ensure compliance with the Class A FCC limits.

### 230V models



This is a Class A product. In a domestic environment this product may cause radio interference, in which case the user may be required to take corrective actions.

2004 <small>Date of product registration</small>		EC Declaration of Conformity	
We, the undersigned, declare under our sole responsibility that the equipment specified below conforms to the following standards and directives:			
<b>Standards to Which Conformity Declared:</b>	EN62040-1-1, EN55022, EN55024, EN61000-3-2, 3-3, 4-2, 4-3, 4-4, 4-5, 4-6, 4-8, 4-11, EN60950-1, IEC60950-1		
<b>Application of Council Directives:</b>	73/23/EEC, 93/68/EEC		
<b>Type of Equipment:</b>	Power Supply		
<b>Model Numbers:</b>	SUM1500RMXL12U, SUM3000RMXL12U		
<b>Manufacturer's Name and Address:</b>			
American Power Conversion (A. P. C.) b. v. Ballybritt Business Park Galway, Ireland	American Power Conversion 132 Fairgrounds Road West Kingston, Rhode Island, 02892, USA		
APC (Suzhou) UPS Co., Ltd 339 Subong Zhong Lu Suzhou Industrial Park Suzhou Jiangsu 215021 P.R. China	American Power Conversion 2nd Street PEZA Cavite Economic Zone Rosario, Cavite Philippines		
American Power Conversion Lot 3, Block 14, Phase 2 PEZA, Rosario, Cavite Philippines	American Power Conversion Lot 10, Block 16, Phase 4 PEZA, Rosario, Cavite Philippines		
<b>Importer's Name and Address:</b>			
American Power Conversion (A. P. C.) b. v. Ballybritt Business Park Galway, Ireland			
<b>Place:</b> N. Billerica, MA U.S.A.	Richard J. Everett, Sr. Regulatory Compliance Engineer		
	<i>Richard J. Everett</i> 5 Jan 03		
<b>Place:</b> Galway, Ireland	Ray S. Ballard, Managing Director, Europe		
	<i>Ray S. Ballard</i> 5 Jan 03		

### **Limited Warranty**

American Power Conversion (APC) warrants its products to be free from defects in materials and workmanship for a period of two years from the date of purchase. Its obligation under this warranty is limited to repairing or replacing, at its own sole option, any such defective products. To obtain service under warranty you must obtain a Returned Material Authorization (RMA) number from customer support. Products must be returned with transportation charges prepaid and must be accompanied by a brief description of the problem encountered and proof of date and place of purchase. This warranty does not apply to equipment that has been damaged by accident, negligence, or misapplication or has been altered or modified in any way. This warranty applies only to the original purchaser who must have properly registered the product within 10 days of purchase.

EXCEPT AS PROVIDED HEREIN, AMERICAN POWER CONVERSION MAKES NO WARRANTIES, EXPRESSED OR IMPLIED, INCLUDING WARRANTIES OF MERCHANTABILITY AND FITNESS FOR A PARTICULAR PURPOSE. Some states do not permit limitation or exclusion of implied warranties; therefore, the aforesaid limitation(s) or exclusion(s) may not apply to the purchaser.

EXCEPT AS PROVIDED ABOVE, IN NO EVENT WILL APC BE LIABLE FOR DIRECT, INDIRECT, SPECIAL, INCIDENTAL, OR CONSEQUENTIAL DAMAGES ARISING OUT OF THE USE OF THIS PRODUCT, EVEN IF ADVISED OF THE POSSIBILITY OF SUCH DAMAGE. Specifically, APC is not liable for any costs, such as lost profits or revenue, loss of equipment, loss of use of equipment, loss of software, loss of data, costs of substitutes, claims by third parties, or otherwise.

Entire contents copyright © 2004 by American Power Conversion Corporation. All rights reserved. Reproduction in whole or in part without permission is prohibited.

APC, Smart-UPS, and PowerChute are registered trademarks of American Power Conversion Corporation. All other trademarks are the property of their respective owners.

## Free Manuals Download Website

<http://myh66.com>

<http://usermanuals.us>

<http://www.somanuals.com>

<http://www.4manuals.cc>

<http://www.manual-lib.com>

<http://www.404manual.com>

<http://www.luxmanual.com>

<http://aubethermostatmanual.com>

Golf course search by state

<http://golfingnear.com>

Email search by domain

<http://emailbydomain.com>

Auto manuals search

<http://auto.somanuals.com>

TV manuals search

<http://tv.somanuals.com>