

# Apex **AW-12** subwoofer

Owners Manual





# ApOEX AWM-12

subwoofer

|                                     |    |
|-------------------------------------|----|
| Introduction_____                   | 1  |
| Important Safety Instructions_____  | 2  |
| Re-cycling_____                     | 3  |
| RoHS Declaration of Conformity_____ | 3  |
| Unpacking_____                      | 4  |
| Spiked Foot Assembly_____           | 4  |
| Amp Panel and Controls_____         | 5  |
| Positioning/Initial Set Up_____     | 8  |
| Set Up_____                         | 8  |
| Specification_____                  | 9  |
| Trouble Shooting_____               | 9  |
| Guarantee and Service_____          | 10 |
| Claims under this Guarantee_____    | 10 |
| EC Declaration of Conformity_____   | 11 |
| Data Protection_____                | 12 |
| Owner Information_____              | 12 |

## Introduction

Thank you for your purchase of the Monitor Audio AW-12 subwoofer, which has been designed and constructed using quality systems and materials to provide years of enjoyment, reliability and pride of ownership.

Music is and should be a natural enhancement of life. It stimulates the imagination, changes your mood, helps you relax, and provides endless hours of entertainment. At Monitor Audio we pride ourselves in attempting to make the listening experience as close as possible to the original 'music' production.

Please read through this manual to familiarize yourself with any safety advice and how to set up your subwoofer to achieve the very best listening experience.

Please retain this manual for future reference.

## Important Safety Instructions

- 1. Read these instructions.**
- 2. Keep these instructions.**
- 3. Heed all warnings.**
- 4. Follow all instructions.**
- 5. Do not use this apparatus with water.**
- 6. Clean only with a dry cloth.** Great care and attention has gone into the materials chosen to produce the AW-12. A gentle wipe with a dry, clean cloth is all that is required to remove any dust. Treat it as you would a fine piece of furniture because that is how they have been designed.
- 7. Do not block any ventilation openings.** Install in accordance with the manufacturers instructions.
- 8. Do not install near any heat source,** such as radiators, heat registers, stoves, or other apparatus (including amplifiers) that produce heat.
- 9. Do not defeat the purpose of the polarised or grounding type plug.** A polarised plug has two blades with one wider than the other. A grounding type plug has two blades and a third grounding prong. The wider blade or the third prong are provided for your safety. If the provided plug does not fit your outlet, consult an electrician for replacement of the obsolete outlet.
- 10. Protect the power cord from being walked on or pinched** particularly at plugs, convenience receptacles, and the point where they exit from the apparatus.
- 11. Only use attachments/ accessories specified by the manufacturer.**
- 12. Use only with the cart,** stand, tripod, bracket, or table specified by the manufacturer or sold with the apparatus. When a cart is used, use caution when moving the cart/ apparatus combination to avoid injury from tip-over.



- 13. Unplug this apparatus during lightening storms,** or when unused for long periods of time.
- 14. Refer all servicing to qualified service personnel.** Servicing is required when the apparatus has been damaged in any way, such as power supply cord or plug is damaged, liquid has been spilled or objects have fallen onto the apparatus, the apparatus has been exposed to rain or moisture, does not operate normally or has been dropped.
- 15. This apparatus shall not be exposed to dripping or splashing water** and that no object filled with liquids such as vases shall be placed on the apparatus.
- 16. This exclamation point within an equilateral triangle** is intended to alert the user to the presence of important maintenance (servicing) instructions in the literature accompanying the appliance.



# WARNING

- **TO PREVENT FIRE OR SHOCK HAZARD, DO NOT USE THIS PLUG WITH AN EXTENSION CORD, RECEPTACLE OR OTHER OUTLET UNLESS THE BLADES CAN BE FULLY INSERTED TO PREVENT BLADE EXPOSURE**
- **TO PREVENT FIRE OR SHOCK HAZARD, DO NOT EXPOSE THIS APPLIANCE TO RAIN OR MOISTURE**
- **TO PREVENT ELECTRIC SHOCK, MATCH WIDE BLADE PLUG TO WIDE SLOT AND FULLY INSERT.**



This lightning flash with an arrow head symbol, within an equilateral triangle, is intended to alert the user to the presence of un-insulated “dangerous voltage” within the product’s enclosure that may be of sufficient magnitude to constitute a risk of electric shock to the persons.

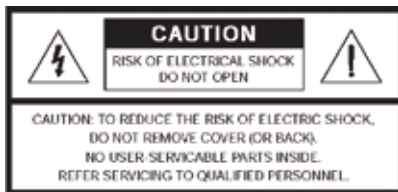

Warning: To reduce the risk of electric shock, do not remove cover (or back), no user-serviceable parts inside. Refer servicing to qualified service personnel.



This exclamation point within an equilateral triangle is intended to alert the user to presence of important maintenance (servicing) instructions in the literature accompanying the appliance.



This is a “Class II”, “double insulated apparatus”. This apparatus must NOT have a safety connection to Earth.

## Re-cycling

Correct Disposal of Waste Electrical and Electronic Equipment (WEEE) by User in Private Households in the EU.

This symbol on the product or accessories indicates that they must not be disposed of with your household wastes throughout the EU. To prevent possible harm to the environment or human health from uncontrolled waste disposal, recycle it responsibly to promote the sustainable reuse of material resources. Instead it is your responsibility to dispose of your waste equipment by handing it over to a designated WEEE collection point for recycling. The separate collection and recycling of your waste equipment will help conserve natural resources and ensure that it is recycled in a manner that protects human health and the environment.

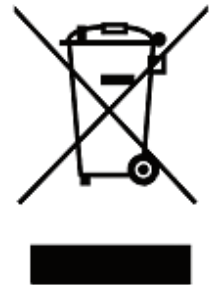

For more specific information about where you can take your equipment for recycling please contact your local city/council office, your local waste disposal service or the outlet where you purchased your Apex product.

## RoHS Declaration of Conformity

Directive 2002/95/EC of the European Parliament and of the Council on the reduction of the use of certain hazardous substances in electrical and electronic equipment, January 2003.



## Background

The RoHS directive restricts the use of Lead (Pb), Cadmium (Cd), Mercury (Hg), hexavalent Chromium (CrVI), polybrominated biphenyl (PBB) compounds, and polybrominated diphenyl ether (PBDE) compounds in electrical and electronic equipment sold in the European Union.

## Unpacking

 **Care must be taken at all times when handling the AW-12 due to the weight of the product. We recommend a two-person lift wherever appropriate.**

 **A feature of the AW-12 is the exposed drive unit. Great care must be exercised at all times to ensure it is not damaged during unpacking and when finally sited in the room. Any physical damage caused to the drive unit by not complying with this requirement will not be covered by warranty.**

The feet/spike assemblies are attached to your product ready to use. The mains power cord is contained separately in the packaging and should be removed prior to unpacking the product.

To remove the AW-12 from its carton place some protective material on the floor and having removed any loose items (mains lead) from the top of the packaging and carefully invert the carton. Also see the icons on the carton. Gradually pull the carton upwards to expose the subwoofer, which will be presented with its base uppermost. Remove fixing tape from plastic bag and expose the base/cabinet. The feet are factory fitted to your product to allow for swift installation and enjoyment of your new purchase. Before turning your AW-12 over so that it is the correct orientation, you must decide how you will be using the feet:

### Spiked Foot Assembly For Wooden/Hard Floors

The engineering behind the foot assembly for the AW-12, has been developed from our initial design in the Silver RS Series, and then in the Gold Signature Series and more recently, the Platinum Series. The foot incorporates a spike for use on carpeted floors and also, a soft polymer cup for use on wooden or tiled floors.



The foot comes fully assembled for use on solid floors where spikes are inappropriate. The assembly incorporates a polymer cup, spike, main threaded assembly and locking nut (exploded image opposite).

To use on solid/ wooden floors (or to use without the spikes), all that is required is turning your cabinet the right way up. Place the cabinet in your desired location, and check that it is level on all sides. If it is slightly off level, unscrew the main threaded assembly at the lowest point and check again. Continue this process until the cabinet is fully level. Use the locking nut on the foot to fix the foot in place and to stop any unwanted vibrations.



### For Carpeted Floors

 **Please ensure there are no hidden wires under the carpet, or trailing mains leads that could be damaged by the spikes.**

For use on carpeted floors, it is possible to reveal the spike from underneath the polymer cup. To use the foot in this manner, carefully pull on the polymer cup (may need to be twisted slightly) away from the main threaded assembly. This should reveal the spike. Place the cabinet in your desired location, and check that it is level on all sides. If it is slightly off level, unscrew the main threaded assembly at the lowest point and check again. Continue this process until the cabinet is fully level. Use the locking nut on the foot to fix the foot in place and to stop any unwanted vibrations.



# Amp Panel & Controls

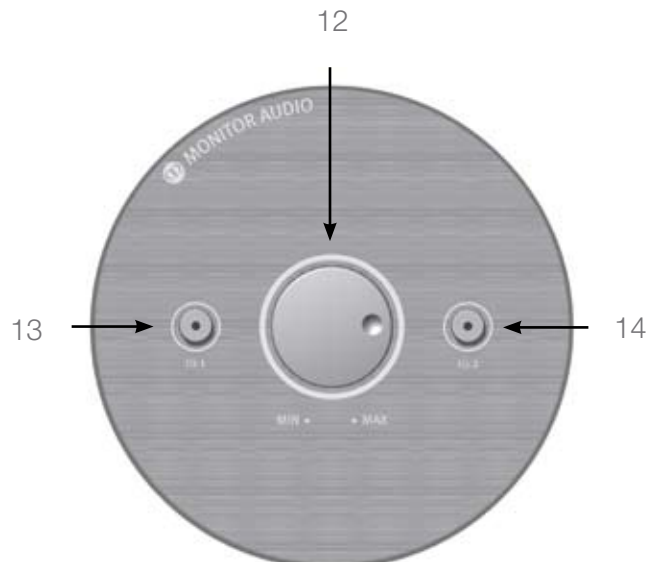
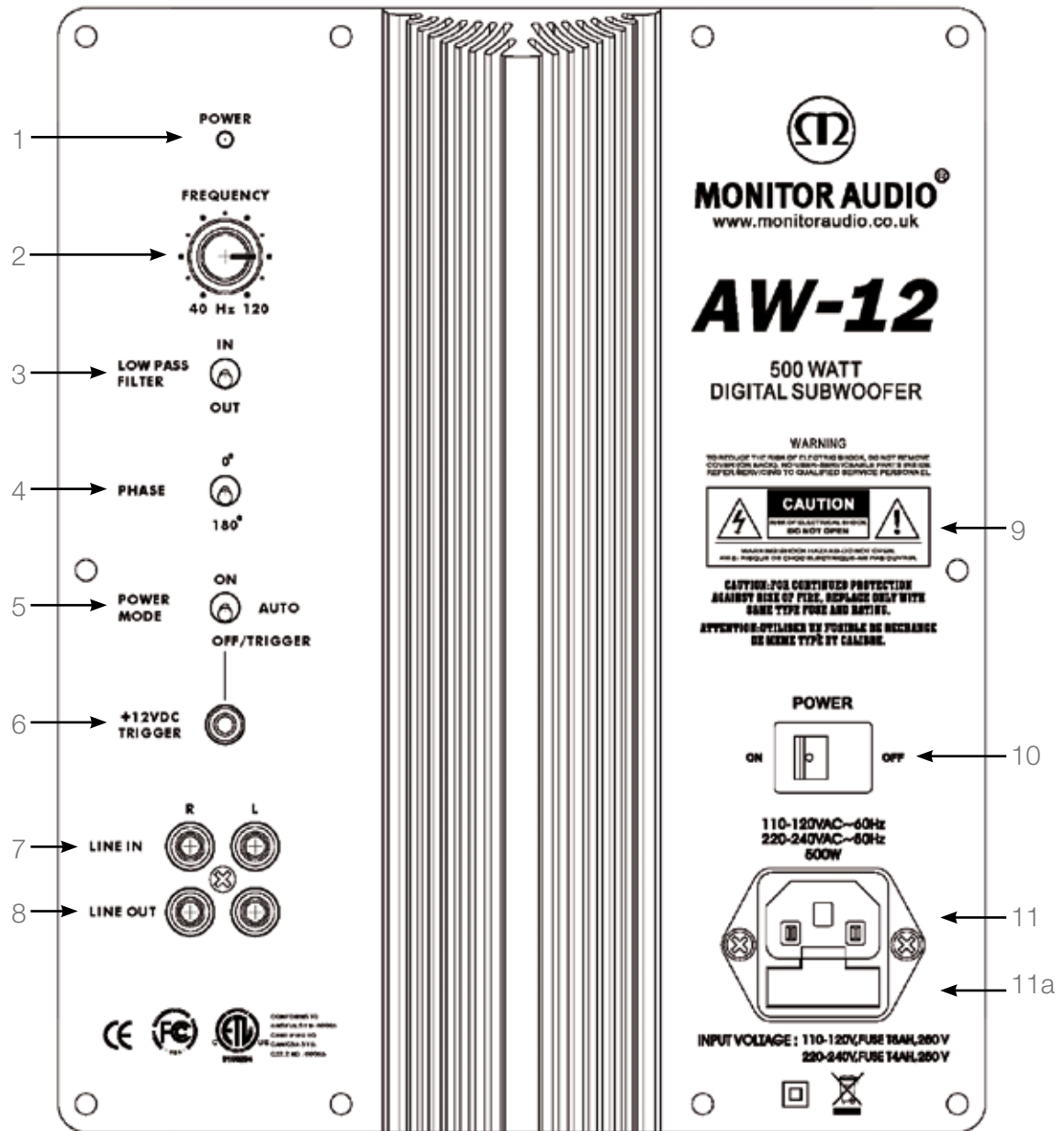

1. Stand-by / On Indicator

The LED indicates whether the unit is in stand-by mode or operational. It will be illuminated red when in stand-by, and green when operational

2. Crossover Frequency Control

The crossover frequency control only operates when the low pass filter switch (refer to section 3.) is in the 'In' position. This control feature is used to set the upper frequency limit (low pass) of the AW-12. The crossover control should be set in accordance with the size or bass output of the main/satellite speakers. Refer to the chart below as a guide to setting the crossover frequency control to the optimum position. Much will depend on the correct low frequency response of the main speakers and their position in your room. Experimentation is advisable.

| Type of Main Speaker                 | Monitor Audio Product         | Crossover Control Setting |
|--------------------------------------|-------------------------------|---------------------------|
| Large floor-standing speaker         | PL300; GS20/60; RS6/8; BR6    | 40-60 Hz                  |
| Small floor-standing speaker         | RS5; BR5; R270                | 50-70Hz                   |
| Large stand-mount/ bookshelf speaker | PL100; GS10                   | 50-80 Hz                  |
| Small stand-mount/ bookshelf speaker | RS1; BR1/2; R225/250; AX40/50 | 60-90 Hz                  |
| Small satellite speaker              | R45/90/180; AX10              | 80-120 Hz                 |

3. Low Pass Filter Switch

When set to the 'In' position the crossover frequency control (section 2) is activated and can be adjusted from 40Hz to 120Hz using the crossover frequency control. When set to the 'In' position it can be used with an amplifier that does not have a dedicated subwoofer or LFE output, such as a stereo 2-channel amplifier. If the amplifier or AV processor has a dedicated LFE or subwoofer output, the Low pass filter switch should be set to the 'Out' position. The low pass filter will then be set by the AV amplifier's internal filter. This should be set in accordance with the amplifier or AV processor user guide.

4. Phase Control Switch

The Phase Control is used to synchronise any delay between the AW-12 and main/satellite speakers. When the AW-12 is in phase with the main/satellite speakers the sound should be full bodied. Sit in a normal listening position whilst adjusting the phase switch. Help from another person may be required in order to do this easily. When set correctly the location of the subwoofer should be almost undetectable. Experimentation is advisable in order to achieve optimum results. However it should be noted that in most cases the phase control switch should be set to 0 degrees, especially when using a digital AV processor or AV receiver amplifier.

5. Power Mode Switch with On-Auto-Off Facility

The Power Mode Switch has three positions: 'On'-'Auto'-'Off'. With the switch in the 'On' position, the subwoofer is permanently switched on under all conditions. In the 'Auto' position the subwoofer will automatically switch on when an input signal is received and will remain on until no signal is received for around 15-20 minutes, the AW-12 will then switch into standby mode until a signal is received once more. When the switch is in the 'Off' position the subwoofer will not function.

6. 12 Volt Trigger Input ~ Centre Pin = +12Vdc

For external power control from AV amplifier/ receiver to the AW-12. Monitor Audio recommend using this function and a lead is supplied. This 12 volt signal is supplied by the AV amp/receiver and tells the AW-12 to turn on from standby mode. This allows a more accurately controlled auto on/off function, and is far more energy efficient. When using this method of connection, it does not matter what position the Power Mode Switch (5) is in, for it to function correctly.

7. RCA Line Level Inputs (Left & Right)

This is the only method of signal input connection to the AW-12. When using a stereo amplifier system, connection can be provided by a pair of high-quality signal cables from the pre-out section of an amplifier. If a digital AV processor or AV receiver/amplifier is to be used, a single cable can be connected from the 'sub out' or LFE connection on the amplifier to the RCA input connection on the AW-12 labelled 'R'. The RCA input marked 'L' in this case will remain unused. Note: - cable lengths should not exceed 10 metres to avoid interference from other electrical appliances.



#### 8. RCA Line Level Outputs (Left & Right)

RCA line level outputs are provided in order to use other sub woofers in conjunction with the AW-12 by 'daisy chain' type connection. The outputs are link out only connections and do not provide any form of filtering.

#### 9. Warning Information

**See warning information on page 3**

#### 10. Mains Power Switch

The Mains Power Switch should be switched to the 'Off' position when the AW-12 will not be used for extended periods. The switch must be in the 'On' position for the subwoofer to function.

**WARNING:** Due to the mains switch being located on the rear panel, the apparatus must be located in the open area with no obstructions to access the mains switch.

#### 11. IEC Mains Power Connector/ Fuse Location

The AW-12 is supplied with a two-pin mains input socket for connection to the mains supply. Use ONLY the appropriate IEC mains lead provided with the product. Also fitted is an external mains fuse. If a fuse blows during operation a spare fuse is provided within the fuse holder for replacement. If you wish to change the fuse, you can do this by removing the IEC mains lead and carefully levering out the original fuse from its holder below the IEC mains input socket (11a). If the fuse blows again it is advisable to seek help from an authorised service agent. DO NOT attempt to re-fit a further fuse as this could result in serious damage to the amplifier unit.

#### 12. Volume Control

This control allows the level or volume to be adjusted in order to achieve a balanced overall sound. To use this facility you will need to play a selection of familiar music or film excerpts. Start with the volume at minimum and increase the level control until a balanced sound is established. If using an AV processor or AV receiver amplifier, the system can be adjusted by the test tone function within the set-up features. (Refer to the set up section in the AV processor or AV receiver amplifier user guide.) When the AW-12 is correctly set-up, you should not be able to identify its location easily in the room.

#### 13. EQ 1 setting

The EQ 1 setting should be set as a default option. This will provide the best overall transient response and power output. This setting will provide a maximally flat response suitable for music or music video. Note: Frequency roll off starts at 27Hz.

#### 14. EQ 2 setting

The EQ 2 setting should be used when an emphasis in the low frequency is required. An additional boost of 4dB will be provided at 21Hz to give impact essential for action movies.

You can toggle between the EQ1 and EQ2 to test which one is best suited to your environment. This is done by pressing the buttons located on the control panel.

The blue LED's of the EQ buttons will remain on permanently. This indicates that the unit is in stand by mode when not in use.

## Positioning/Initial Set Up

**Leave the AW-12 unplugged from the mains until the installation procedure is completed.** The AW-12 should now be sited in the most suitable position, preferably not directly in the corner of a room as this may cause excessive bass boom. Once a desirable position is achieved it is important to check if the cables are long enough to reach comfortably without being under tension. The optimal control settings will depend entirely on your system configuration. For initial trials set the controls as follows:

|                        |  |
|------------------------|--|
| Volume Control         | Should be set to minimum   |
| Frequency Control      | Should be set to the minimum position (40Hz)   |
| Phase Control          | Should be set to zero degrees  |
| Power Mode Switch      | Should be set to 'Auto' (if not using 12v trigger)   |
| 12v Trigger            | Should be connected using the supplied (or similar) lead to the output from your AV amplifier. |
| EQ Setting             | This will be set as EQ1 by default when powered up   |
| Low Pass Filter Switch | Should be set to the 'Out' position  |

Input connections can be made at this stage before the power is connected to the AW-12.

 **Never connect or disconnect the RCA input/ output lead connection with the AW-12 switched on.**

## Set Up

Once the input cables are connected and the controls are set in accordance with the initial set-up procedure above, the AW-12 can be connected to the mains power supply and switched on at the mains power switch. Do not play any music at this stage. With the 12v trigger connected or Power Mode Switch in the 'Auto' position, the unit should remain in standby (Power LED on the amp panel should be red, and the EQ1 button illuminated blue) until the AV amp is turned on or a signal is received (when not using the 12v trigger).

Play a variety of music/ film excerpts that you are familiar with starting at a very low volume level, increasing to an average listening level once you are sure everything is working correctly. Please now follow the bulleted instructions below: -

- For use with an AV amp/receiver (product with Subwoofer output) please select the low pass filter switch to the 'Out' position. Otherwise select low pass filter switch to the 'On' position. This engages the crossover frequency control on the subwoofer (please refer to page 6).
- If using the crossover frequency control please adjust in accordance with the table on page 6. Further fine-tuning may be required.
- Adjust the Volume Control to desired level for initial trials, ref. page 7
- The Phase Control can now be set, please refer to page 6 for further information.

It is important to try a variety of music and film excerpts with which you are familiar in order to obtain the optimum overall settings.

## Specification

|   |  |
|---|--|
| Low frequency limit:-                                   | 27Hz (EQ1) 21Hz (EQ2)  |
| Upper frequency limit:-                                 | 40 – 120 Hz Variable   |
| Low pass filter alignment:-                             | Active 4th order 24db/octave (two-stage filter)  |
| Cabinet Specification: -                                | Sealed Cabinet of 25mm M.D.F construction with internal bracing  |
| Amplifier Output:-                                      | 500 Watts (RMS) 1000 Watts (Peak)  |
| Amplifier classification:-                              | Class- D Digital amplifier   |
| Driver compliment:-                                     | 1 x 12" C-CAM® subwoofer driver featuring triple suspension and 3" long throw voice coil   |
| Dimensions:-<br>(H x W x D)                             | Millimetres:- 340 x 340 x 370<br>Inches:- 13 <sup>3</sup> / <sub>8</sub> x 13 <sup>3</sup> / <sub>8</sub> x 14 <sup>1</sup> / <sub>2</sub> |
| Weight (unpacked):-                                     | 25.5 Kg (56lbs)  |
| Input Impedance: -                                      | 20K Ohms   |
| Mains input voltage:-<br>(Electronically Auto selected) | 110 - 120 Vac / 220 - 240 Vac 50/60Hz  |

C-CAM® is a registered trade mark of Monitor Audio Ltd

## Trouble Shooting

Should you experience any technical, or set-up problems with your AW-12 please check the Trouble Shooting Guide below:

My AW-12 will not turn on/no power.

- Is the LED illuminated on the back of the unit? If not, then check your mains lead is properly connected both at the AW-12 and at the mains outlet. Also check the fuse of the mains plug (where fitted) and also the fuse in the AW-12. See page 7 for further information on changing the fuse and it's location.
- Is the LED on the back red? If so, you have power going to the unit. It could be that there is no signal, or the 12v trigger is connected and the source not turned on (see below).
- Have you got the 12v trigger connected? If so, the AW-12 will not power up until the source is powered up.
- Has it got a signal going to it (12v trigger not being used)? If so, is the Power Mode Switch in the Auto or On position, and the signal source is turned on? Try adjusting the volume level of the source.

If it still does not turn on/ power up, please contact your local dealer/ distributor or Monitor Audio immediately.

No sound from AW-12.

- Is the LED on the back red or green? If it is red, then the unit hasn't actually turned on. See above comments. If it is green, then your unit is powered up and turned on. Check further suggestions below.
- Are the signal leads connected correctly? Check these. If possible, check with a second, known to be working set.
- Is the volume level just very low?

If it still does not output a signal, please contact your local dealer/ distributor or Monitor Audio immediately.

## Guarantee and Service

Valid upon completion of the incorporated warranty card and its return within 30 days of purchase.

This equipment has been fully tested prior to dispatch from the factory. Both the craftsmanship and the performance of this product is guaranteed against manufacturing defects for the period of one year from the date of purchase (see conditions below), provided that the product was supplied by an authorised Monitor Audio retailer under the consumer sale agreement. (The words 'consumer sale' shall be construed in accordance with section 15 of the supply of goods act 1973). Monitor Audio accepts no responsibility for defects arising from accident, misuse, abuse, wear and tear, modification or operation outside of that specified within this instruction manual. Neither will responsibility be accepted for damage or loss occurring during transit to or from the parties claiming under this guarantee.

This guarantee covers both labour and parts. The liability of Monitor Audio is limited to the cost of repair or replacement of the defective parts (at the discretion of Monitor Audio) and under no circumstances extends to consequential losses or damage.

### Claims under this Guarantee

The equipment should be returned in its original packaging to the original supplier where possible, or to any other authorised Monitor Audio dealer. If it is not possible to return the equipment by hand, then it should be sent carriage prepaid via a reputable carrier. If the original packing is not available replacement packaging can be purchased from Monitor Audio. If you have any difficulties complying with these requirements please contact us at the following address:

Customer Service  
Monitor Audio Ltd.  
Unit 2, 24 Brook Road  
Rayleigh  
Essex  
SS6 7XL  
England

Tel: 44 (0) 1268 740580  
Fax: 44 (0) 1268 740589  
Internet: [www.monitoraudio.co.uk](http://www.monitoraudio.co.uk)  
Email: [info@monitoraudio.co.uk](mailto:info@monitoraudio.co.uk)

This guarantee does not affect the statutory rights of the consumer under UK law.

**EC Declaration of Conformity**

**We**, Monitor Audio Ltd.  
Unit 2,24 Brook Road  
Rayleigh  
Essex  
SS6 7XL  
England



Declare in own responsibility, that the AW-12 product described in this manual is in compliance with Technical Standards/Council Directives:

**(LVD) 73/23/EEC Low Voltage Directive**

**EN60065:** 09.93+ A11:09.97 Safety requirements for mains operated electronic and related apparatus for household and similar use.

**(EMC) 89/336/EEC Electro Magnetic Compatibility**

**EN55013:** 08.90+A12:08.94+A13:12.96 Limits and methods of measurement of radio disturbance characteristics of broadcast receivers and associated equipment.

**EN55020:** 12.94+A11:12.96 Electro magnetic immunity of broadcast receivers and associated equipment.

**EN61000-3-2:** 04.95+A1:1998+A2:1998 Electro magnetic compatibility (EMC) – Part 3: Limits – Section 2: Limits for harmonic current emissions (equipment input current up to and including 16 Ampere per phase).

**EN6100-3-3: 01.95** Electro magnetic compatibility (EMC) – Part 3: Limits – Section 3 : Limits of voltage fluctuations and flicker in low-voltage supply systems for equipment with rated current up and including 16 Ampere per phase.

**Signed by:**

A handwritten signature in black ink, appearing to be 'D.S. Hartley'.

**Name:** D.S. Hartley

**Position:** Technical Director

**Company:** Monitor Audio Ltd

## Data Protection

We at Monitor Audio are committed to respecting the wishes and privacy of our customers. Any information you provide will be held in the strictest confidence and only used within the Monitor Audio organisation for the provision of services such as warranty claims or spare parts.

We may wish to contact you in the future to ensure you are happy with the products and standards of service we provide and to keep you up-to-date with the latest products and promotions we have to offer.

Should you wish not to be contacted by us either by post, e-mail or phone, please tick the box on the warranty card. Alternatively you can request not to be contacted in future by writing to Customer Service, at the address on the previous page.

## Owner Information

### Product Details

Model AW-12

Product Serial No .....

Amp panel Serial No .....

Date of Purchase .....

### Dealer Details

Dealer Name .....

Address .....

Town, Post code, Country .....

e-mail address .....

Monitor Audio reserves the right to alter specifications without notice.





Monitor Audio Ltd.  
Unit 2, 24 Brook Road  
Rayleigh, Essex  
SS6 7XL  
England  
Tel: 01268 740580  
Fax: 01268 740589  
Email: [info@monitoraudio.co.uk](mailto:info@monitoraudio.co.uk)

[monitoraudio.co.uk](http://monitoraudio.co.uk)  
**Designed in the United Kingdom**

Version 1. 2007



## Free Manuals Download Website

<http://myh66.com>

<http://usermanuals.us>

<http://www.somanuals.com>

<http://www.4manuals.cc>

<http://www.manual-lib.com>

<http://www.404manual.com>

<http://www.luxmanual.com>

<http://aubethermostatmanual.com>

Golf course search by state

<http://golfingnear.com>

Email search by domain

<http://emailbydomain.com>

Auto manuals search

<http://auto.somanuals.com>

TV manuals search

<http://tv.somanuals.com>