

APOLLO AE-SERIES ELECTRIC ACTUATORS

General Installation, Operation, Specifications, Maintenance and Trouble Shooting Instructions

The following is intended as a guide only in installing and operating the electric actuator. The manufacturer assumes no liability whatsoever for any personal injury or other special or consequential damages that may occur. There are no warranties as to suitability for a specific application or purpose.

Installation / Mechanical Operation

- Verify that the valve breakaway torque is less than the rated output torque of the actuator.
- Any mechanical stops that would interfere with the operation of the actuator must be removed before installation of the actuator, i.e. lever, travel stops, etc.
- The actuator output coupling must be centered with the valve stem to prevent side loading, which causes premature stem packing wear.
- The AE-Series actuator is not recommended for actuation of butterfly valves or other similar resilient seated valves, unless installed with Motor Break option.
- To use the manual override feature (identified on cover label), the override shaft must be pressed down firmly at least 1/4" in order to disengage the motor from the gears. The manual override is not designed to overcome torque in excess of the rated torque of the actuator. Serious damage to the gear system may result from excessive turning force on the manual override.
- The AE-Series actuator may be mounted in any position, i.e. horizontal, upside down. If the conduit entrance points upward, conduit piping must be oriented as to prevent condensation from entering the actuator from the conduit pipe.

Electrical Operation

- Always verify that the supply voltage and required voltage are the same.
- AE-series 24VAC, 115VAC and 230VAC actuators use capacitor run-reverse induction motors, which create higher feedback voltages than the supply voltage. Control devices connected to terminals 3 and 4 must be rated for 250VAC minimum for 115VAC actuators, (440VAC min. for 230VAC actuators: 125VAC min. for 24VAC).
- Do not wire actuators in series or parallel with another actuator or other electrical equipment due to the induction feedback voltage created by the motor.
- Separate (isolated contacts) are required for each actuator.
- When wiring DC voltage actuators, verify that terminal polarity is correct (pos.+ & Neg.-). Failure to do so will cause the actuator to operate out of its normal 90 degree rotation.
- The AE-Series actuators are designed to operate at 25% duty cycle at temperatures below 100°F. This means that for a cycle time of 25 seconds the actuator must rest for 75 seconds. This is an average. For example: The actuator may cycle several times in a row, but must rest for a period 75% longer than the time it operated.
- All models require electrical power to both OPEN and to CLOSE the actuator and valve.

Maintenance

Under normal circumstances the actuator will not require additional lubrication. All of the actuator's essential components are permanently lubricated at the factory.

- Seal conduit entrances to prevent water or dirt from entering the housing. Excessive moisture can cause premature wear or corrosion within the housing.
- Periodically inspect actuator and valve assembly for worn parts, loose fasteners, or damage to the outside of the unit.

General Specifications

Actuator Model	Breakaway Torque Output (in.-lbs.)	Cycle Time 90° Travel (50% Load)	Duty Cycle*	Amperage Draw (max.) Starting or locked rotor current voltage				
				24 VAC	115VAC	230VAC	12VDC	24VDC
AE200	200 in-lbs.	5.0 sec.	25%	4.56 amp	.74 amp	.44 amp	2.00 amp	1.38 amp
AE400	400 in-lbs.	10.0 sec.	25%	4.56 amp	.74 amp	.44 amp	2.00 amp	1.38 amp
AE600	600 in-lbs.	15.0 sec.	25%	4.56 amp	.74 amp	.44 amp	2.00 amp	1.38 amp
AE800	800 in-lbs.	20.0 sec.	25%	4.56 amp	.74 amp	.44 amp	2.00 amp	1.38 amp
AE1000	1000 in-lbs.	25.0 sec.	25%	4.56 amp	.74 amp	.44 amp	2.00 amp	1.38 amp

Note: 90° Travel = Travel From Closed position to Open position or vice versa.

* Duty Cycle for 24VAC will be approximately 20%.

Motor	AC models: 24 VAC, 120 VAC or 230 VAC, Reversible. 3 wire, capacitor run. Self-resetting thermal overload protection, Class B insulation, sub-fractional horsepower. DC models: 12 VDC or 24 VDC, Reversible. 2 wire, POS. & NEG. No thermal overload (external circuit breaker or fuse suggested for protection).
Lubrication	Permanently lubricated gear train and bearings.
Duty Cycle	The AE-Series actuators are designed to operate at 25% duty cycle at temperatures below 100°F. See Electrical Operation.
Temperature Operating Range	32°F to 150°F standard -40°F to 150°F with optional heater & thermostat
Thermal Protection	Self-resetting (AC Motors Only)
Conduit Connections	(2) 1/2"-NPT female
Direction Of Travel	Clockwise to Close, Counterclockwise to Open (Position indicator shaft only, manual override shaft rotates opposite)

AE-SERIES NUMBERING SYSTEM

Constant	Torque	Voltage	Options
	200	1 = 115 vac	0 = Standard
	400	2 = 24 vac	A = One extra switch & cams
	600	3 = 220 vac	B = Two extra switches & cams
	800	4 = 12 vac	C = Three extra switches & cams
	1000	5 = 24 vac	D = Heater & Thermostat
			E = Single Potentiometer
			F = Motor Break
	Enter all digits of Torque value		

Note: AE will always be the first two characters of the part number, all digits from torque value must be entered into part number (i.e. 400, 1000 etc.). Only use one digit for voltage depiction (i.e. 1-5). For the options listing you may use more than one character, up to three (i.e. 0, AD or BD etc.).

24/115/230 VAC Wiring Diagram

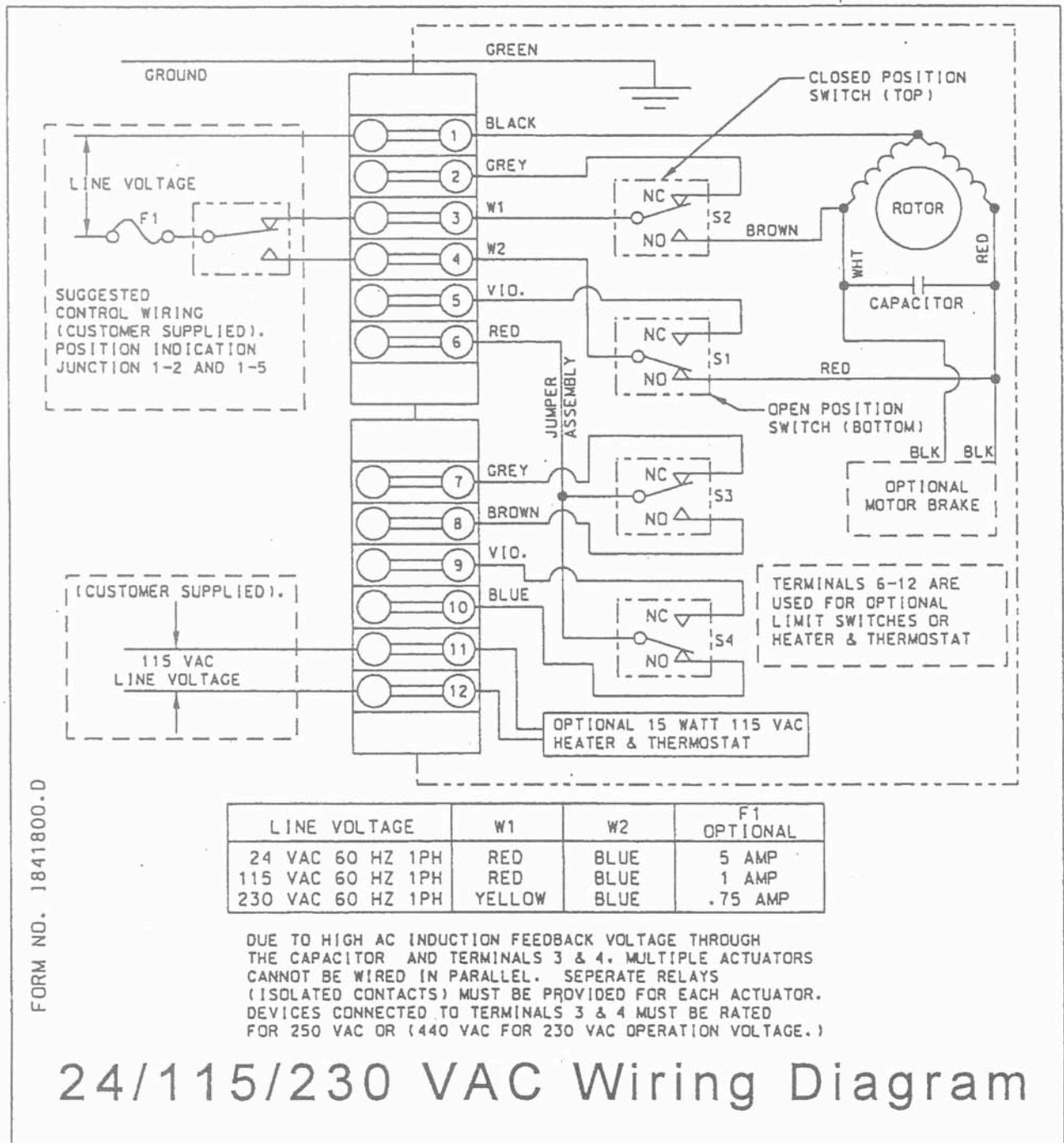

SUGGESTED CONTROL WIRING (CUSTOMER SUPPLIED). POSITION INDICATOR JUNCTION 1-2 AND 1-5.

(CUSTOMER SUPPLIED).
115 VAC LINE VOLTAGE

CLOSED POSITION SWITCH (TOP)

OPEN POSITION SWITCH (BOTTOM)

OPTIONAL MOTOR BREAK

TERMINALS 6-12 ARE USED FOR OPTIONAL LIMIT SWITCHES OR HEATER & THERMOSTAT

OPTIONAL 15 WATT 115 VAC HEATER & THERMOSTAT

LINE VOLTAGE	W1	W2	F1 OPTIONAL
24 VAC 60 HZ 1 PH	RED	BLUE	5 AMP
115 VAC 60 HZ 1 PH	RED	BLUE	1 AMP
230 VAC 60 HZ 1 PH	YELLOW	BLUE	.75 AMP

DUE TO HIGH AC INDUCTION FEEDBACK VOLTAGE THROUGH THE CAPACITOR AND TERMINALS 3 & 4, MULTIPLE ACTUATORS CANNOT BE WIRED IN PARALLEL. SEPARATE RELAYS (ISOLATED CONTACTS) MUST BE PROVIDED FOR EACH ACTUATOR. DEVICES CONNECTED TO TERMINALS 3 & 4 MUST BE RATED FOR 250 VAC OR (440 VAC FOR 230 VAC OPERATION VOLTAGE).

12/24 VDC WIRING DIAGRAM

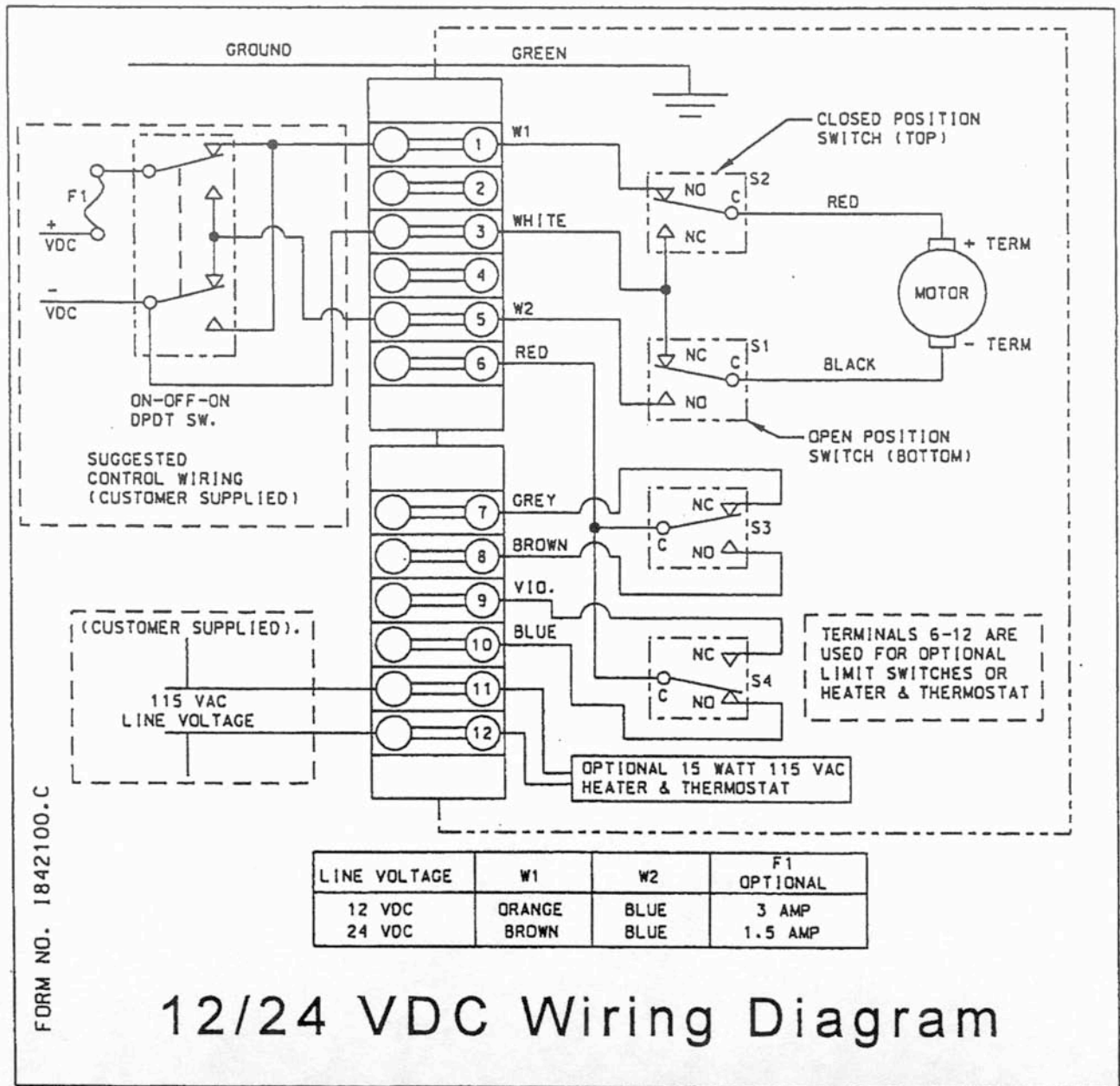

ON-OFF-ON DPDT SW.

SUGGESTED CONTROL WIRING (CUSTOMER SUPPLIED)

(CUSTOMER SUPPLIED).

115 VAC LINE VOLTAGE

CLOSED POSITION SWITCH (TOP)

RED +TERM
MOTOR – TERM BLACK

OPEN POSITION SWITCH (BOTTOM)

TERMINALS 6-12 ARE USED FOR OPTIONAL LIMIT SWITCHES OR HEATER & THERMOSTAT

OPTIONAL 15 WATT 115 VAC HEATER & THERMOSTAT

LINE VOLTAGE	W1	W2	F1 OPTIONAL
12 VDC	ORANGE	BLUE	3 AMP
24 VDC	BROWN	BLUE	1.5 AMP

MANUAL OVERRIDE SHAFT .312 SQUARE

OPTIVE SCREWS ARE 1/4" – 20 UNC SOCKET HEAD CAP SCREWS, 6 PLACES

INDICATOR – SHOWN IN CLOSED POSITION

1/2" NPT, TYPICAL BOTH SIDES

3.5" CLEARANCE (FROM TOP OF OVERRIDE SHAFT) REQUIRED FOR COVER REMOVAL

5/16-18 UNC X .62 DEEP
4 PLACES TYPICAL

02.756 B.C.

.748 SQUARE
.747 X .87 DEEP

.975

1.949 SQUARE

MOUNTING PATTERN ISO 5211 – F07

AE-SERIES DIMENSIONS

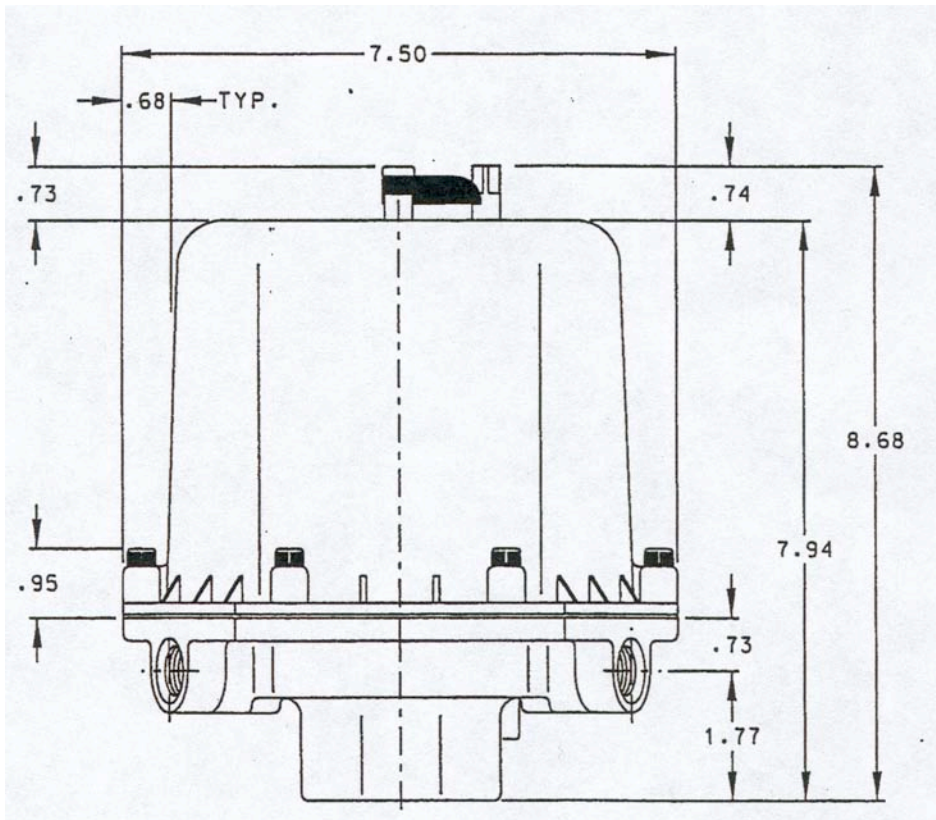
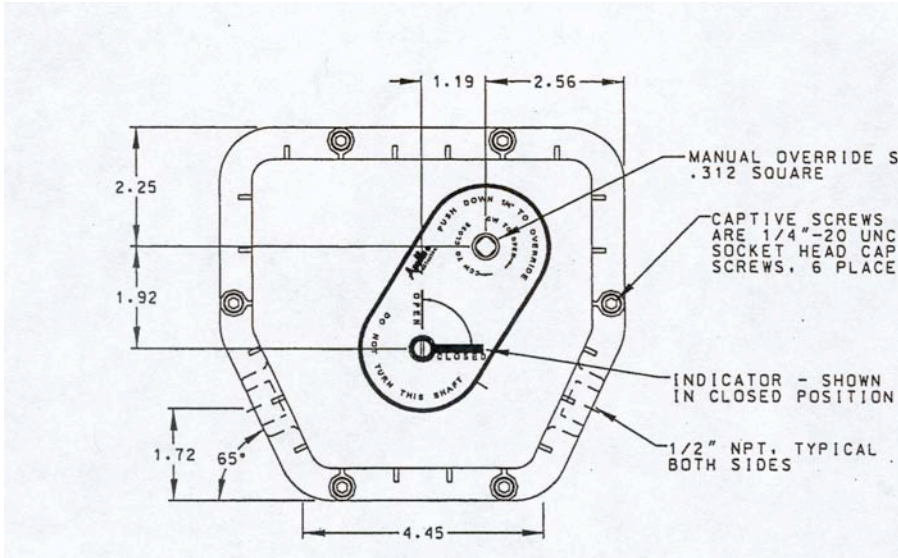

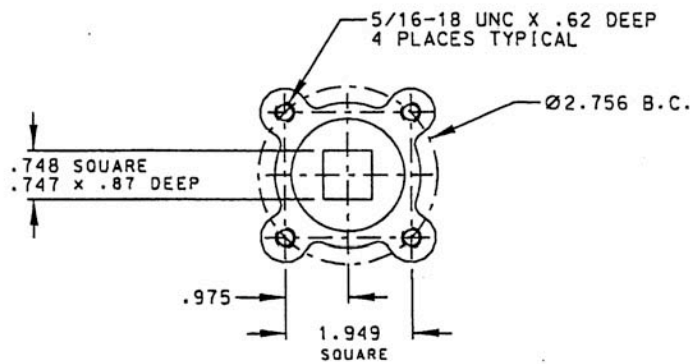
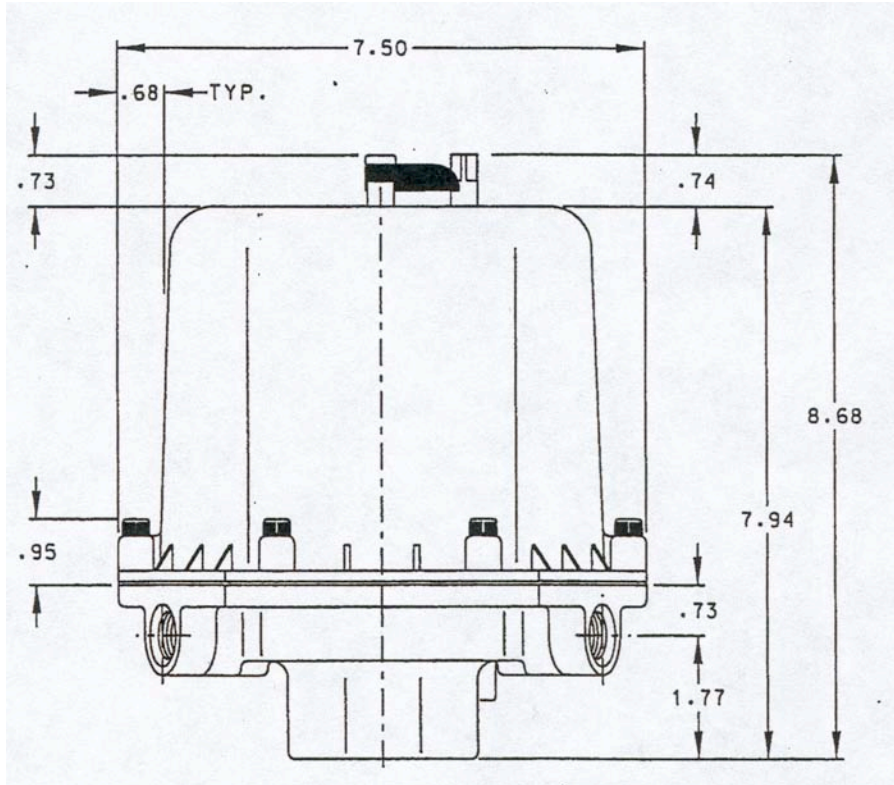

MOUNTING PATTERN ISO 5211 - F07

Free Manuals Download Website

<http://myh66.com>

<http://usermanuals.us>

<http://www.somanuals.com>

<http://www.4manuals.cc>

<http://www.manual-lib.com>

<http://www.404manual.com>

<http://www.luxmanual.com>

<http://aubethermostatmanual.com>

Golf course search by state

<http://golfingnear.com>

Email search by domain

<http://emailbydomain.com>

Auto manuals search

<http://auto.somanuals.com>

TV manuals search

<http://tv.somanuals.com>