

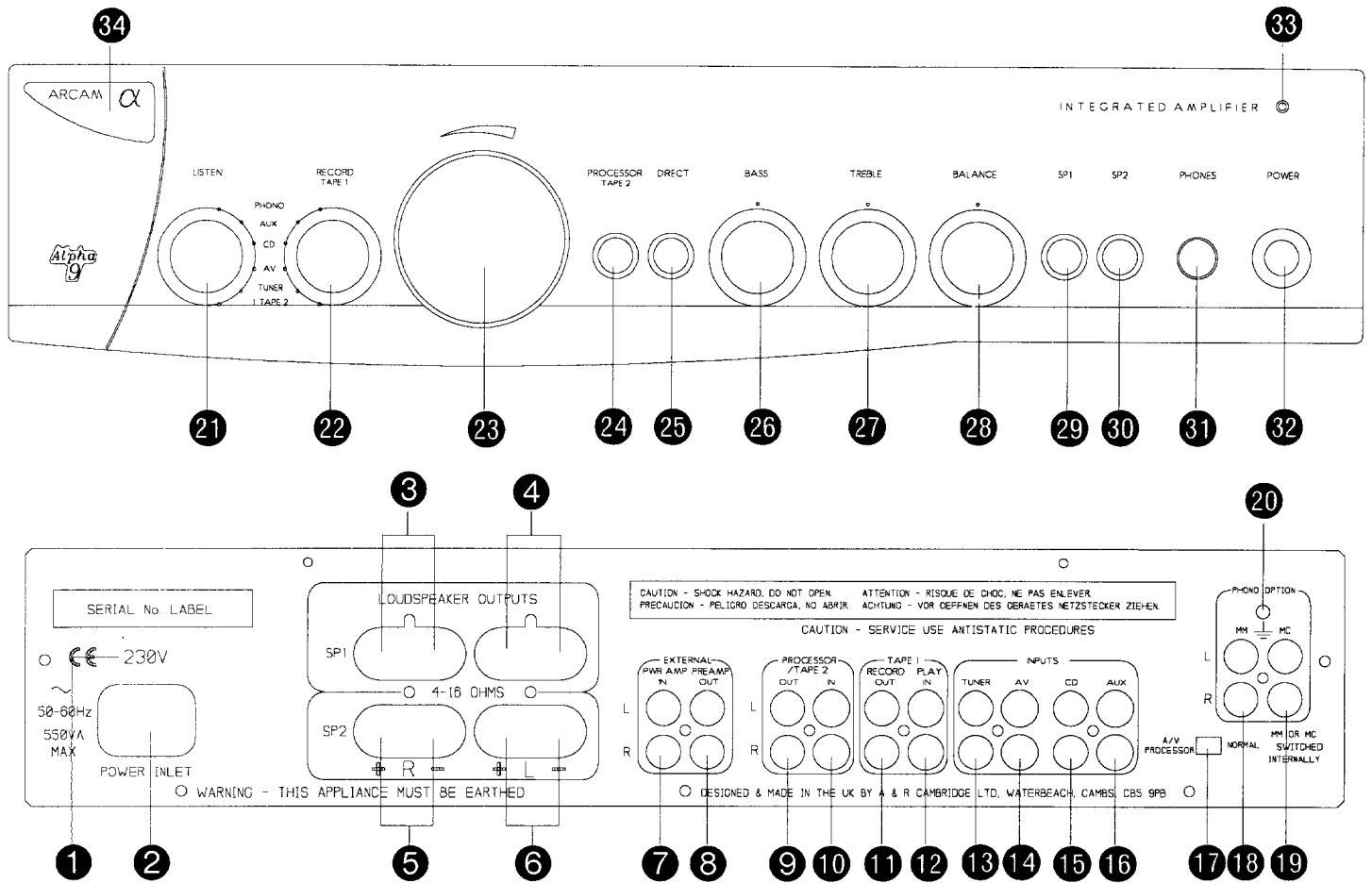

ARCAM

**ALPHA 9/9P AMPLIFIER
HANDBOOK**

Front & Rear Panel Diagrams



Alpha 9 Integrated Amplifier

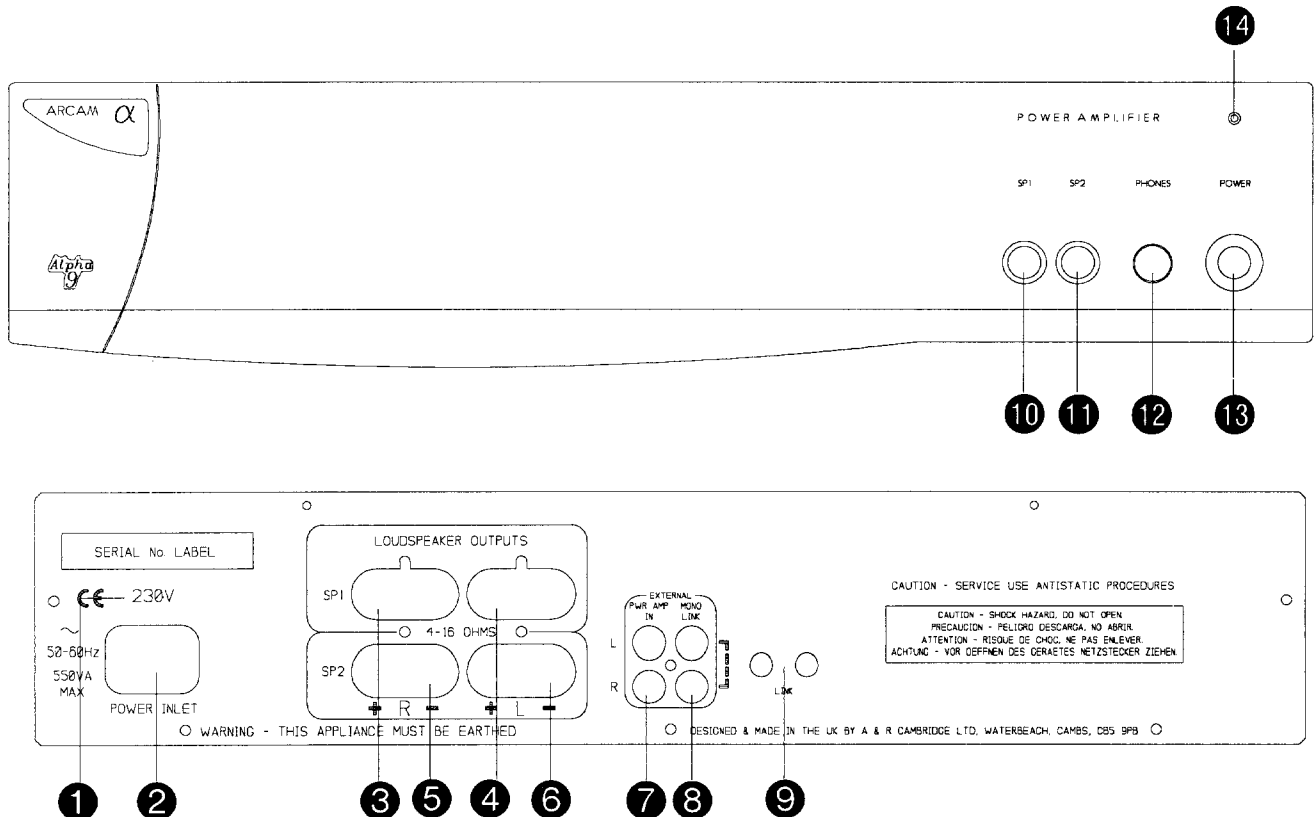

Alpha 9P Power Amplifier

SAFETY INSTRUCTIONS

This product was designed and manufactured to meet strict quality and safety standards. There are, however, some installation and operation precautions which you should be particularly aware of:

1. **Read Instructions** - All the safety and operating instructions should be read before the appliance is operated.
2. **Retain Instructions** - The safety and operating instructions should be retained for future reference.
3. **Heed Warnings** - All warnings on the appliance and in the operating instructions should be adhered to.
4. **Follow Instructions** - All operating and use instructions should be followed.
5. **Water and Moisture** - The appliance should not be used near water - for example near a bathtub, washbowl, kitchen sink, laundry tub, in a wet basement or near a swimming pool, etc.
6. **Carts and Stands** - The appliance should be used only with a cart or stand that is recommended by the manufacturer.
- 6A. An appliance and cart combination should be moved with care. Quick stops, excessive force, and uneven surfaces may cause the appliance and cart combination to overturn.
7. **Wall or Ceiling Mounting** - The appliance should be mounted to a wall or ceiling only as recommended by the manufacturer.
8. **Ventilation** - The appliance should be situated so that its location or position does not interfere with its proper ventilation. For example, the appliance should not be situated on a bed, sofa, rug or similar surface that may block the ventilation openings or placed in a built-in installation, such as a bookcase or cabinet that may impede the flow of air through the ventilation openings.
9. **Heat** - The appliance should be situated away from heat sources such as radiators, heat registers, stoves or other appliances (including amplifiers) that produce heat.
10. **Power Sources** - The appliance should be connected to a power supply only of the type described in the operating instructions or as marked on the appliance.
11. **Grounding** - Precautions should be taken so that the grounding means of the appliance is not defeated.
12. **Power-Cord Protection** - Power supply cords should be routed so that they are not likely to be walked on or pinched by items placed upon or against them, paying particular attention to cords and plugs, convenience receptacles and the point where they exit from the appliance.
13. **Cleaning** - Unplug the unit from the mains supply before cleaning. The appliance should normally only require a wipe over with a clean, dry, lint-free cloth. If it is heavily soiled then a cloth slightly dampened with a water/washing up liquid solution may be used. Dry the unit afterwards with a dry cloth. We do not advise the use of furniture type cleaning sprays/polishes as this can cause white marks, which are very difficult to remove, if the unit is then wiped over with water.
14. **Power Lines** - An outdoor antenna/ aerial should be located away from power lines.
15. **Non-use Periods** - The power cord of the appliance should be unplugged from the outlet when left unused for a long period of time.
16. **Object and Liquid Entry** - Care should be taken so that objects do not fall and liquids are not spilled into the enclosure through any openings.
17. **Abnormal Smell** - If an abnormal smell or smoke is detected from the appliance, immediately turn the power off and unplug the unit from the wall outlet. Contact your dealer immediately.
18. **Damage Requiring Service** - The appliance should be serviced by qualified service personnel when:
 - A. The power-supply cord or the plug has been damaged or:
 - B. Objects have fallen, or liquid has spilled into the appliance or:
 - C. The appliance has been exposed to rain or:
 - D. The appliance does not appear to operate normally or exhibits a marked change in performance or:
 - E. The appliance has been dropped or the enclosure damaged.
19. **Servicing** - The user should not attempt to service the appliance beyond that described in the operating instructions. All other servicing should be referred to qualified service personnel.

INTRODUCTION

The Arcam Alpha 9 integrated amplifier, is derived from the highly successful Arcam Delta 290 model. It is rated at 70 watts per channel into 8 ohms. The Alpha 9 is extremely versatile and suitable for both conventional and Audio Visual (home cinema) based systems.

It can be used as an integrated amplifier or as a preamplifier to drive external power amplifiers. The preamp out sockets also allow the addition of an Alpha 9P power amplifier to give a true bi-amplified system. In this configuration the power amplifiers within the Alpha 9 integrated amplifier are retained to drive the loudspeakers' treble units whilst using the Alpha 9P to drive their bass/midrange units.

In addition to this the Alpha 9 integrated amplifier can also be used as a stand alone power amplifier via its "power amp in" sockets or combined with suitable loudspeakers and an AV processor, such as the Arcam Xeta 2, to form a very high performance home cinema system.

The Alpha 9P is a matching 70 watts per channel power amplifier designed to complement the Alpha 9 integrated amplifier. It offers an easy upgrade path for owners of the Alpha 9 integrated amplifier (or the Delta 290 integrated amplifier) to provide a bi-amplified system.

It may also be used with Arcam's Alpha 7 and 8 integrated amplifiers, either as a simple power booster or as part of a high performance bi-amplified system.

It can be used with almost any preamplifier and is ideal for upgrading both hi-fi and Audio Visual systems.

This manual is in four parts:

- A. This section has information relevant to both the Alpha 9 and Alpha 9P.
- B. Alpha 9 integrated amplifier operating instructions.
- C. Alpha 9P power amplifier operating instructions.
- D. Instructions on how to bi-wire or to bi-amplify ("bi-amp") your loudspeakers.

N.B. Circled numbers e.g. ❷ refer to items on the diagrams inside the flap of the front cover.

Section A

INSTALLATION

- ❶ Check that your mains supply voltage agrees with the voltage setting indicated on the rear panel of the unit.
 - If your mains supply voltage is different, consult your Arcam dealer.

MAINS SAFETY

- This product is normally supplied with a moulded mains plug already fitted to the lead. If for any reason the plug needs to be removed, it **must be disposed of immediately and securely**, as it is a potential shock hazard when inserted into a mains socket.
- **Warning:** This apparatus must be earthed.

NOTICE FOR U.K. OWNERS ONLY

- If the plug is removed then the remaining lead must be rewired as follows:
- The **blue** wire must be connected to the terminal which is coloured **blue** or marked with the letter **N**.
- The **brown** wire must be connected to the terminal which is coloured **brown** or marked with the letter **L**.
- The **green and yellow** wire must be connected to the terminal which is coloured **green and yellow**, or marked with the letter **E** or the safety earth symbol.
- When replacing the fuse in the supplied moulded mains plug, the integral fuse holder/cover must always be refitted. Use a 5 amp fuse.

SAFETY STANDARD

- This product has been designed to meet the IEC 61010 international electrical safety standard.

MAINS SUPPLY CONNECTIONS

- ❷ Insert the IEC line socket of the mains lead fully into the power inlet on the rear panel. Connect the other end to your mains supply.

CAUTION: Your Alpha 9 and Alpha 9P generate heat when in use, particularly at higher volumes. It is therefore most important never to obstruct the ventilation slots on the top and bottom of the unit as this will cause overheating.

If the temperature of the internal heatsinks rises above a safe level, then a thermal cut out inside the amplifier will operate. The POWER LED on the front panel will turn amber and the output protection relays will temporarily remove the feed to the loudspeakers. The system will reset itself as the heatsinks cool down.

Please note that under certain conditions it is possible for the Alpha 9 or Alpha 9P's thermal cut out to operate when playing music at very high levels.

This might for example happen when continuously playing heavily compressed rock music "flat out" into low impedance (4-6 ohm) speakers. If this happens to you, the cure is to turn the volume down slightly and ensure the amplifier is properly ventilated.

It is important to point out that when playing a heavily recorded CD it is possible to drive the Alpha 9 at full power despite the fact that the volume control is only at 10 or 11 o'clock. This is because of the high output voltage from a CD player. However the Alpha 9 also has to be capable of giving full power output from much lower level sources, such as tuners and cassette decks. Using these sources, the volume control setting will be much higher before overload sets in.

Please refer to drawing inside front cover.

LOUDSPEAKER CONNECTIONS

- The amplifier is fitted with BFA (British Federation of Audio) loudspeaker connectors, which are designed to meet EU safety standards. The BFA connector will accept spade terminals, bare wires up to 4mm in diameter or a BFA plug. BFA plugs are available from your Arcam dealer.

- The speaker terminals are colour coded red for positive and black for negative. These terminals are also labelled 'R' for the right channel speakers and 'L' for the left channel speakers.

3, 4 Connect terminals 3 to your right speaker and terminals 4 to your left speaker, ensuring correct polarity.

- Connect the red cable termination to the red terminal and the other cable termination to the black terminal. If your speaker cable has bare ends, the positive conductor can usually be identified by a ridge or coloured marking. Ensure that no stray strands are allowed to touch another cable or the amplifier's casing. This can cause a short circuit and damage your amplifier!

5, 6 To drive a second pair of speakers, connect terminals 5 to the right speaker and terminals 6 to the left speaker, ensuring correct polarity.

- The Alpha 9 can drive two pairs of loudspeakers, simultaneously if required, providing both pairs are rated between 8 and 16 ohms. Either pair can be selected using the switches labelled SP1 and SP2 on the front panel. To avoid overheating, the combined load impedance as seen by the amplifier should not fall below 4 ohms per channel.

CONNECTING YOUR SOURCE COMPONENTS

- Using a suitable pair of interconnect cables, insert the red phono plugs into the sockets labelled 'R' and the other phono plugs into the sockets labelled 'L'.

All the line inputs (not PHONO) have the same sensitivity and may be used with equipment other than that labelled, if you need to do so.

- 9 PROCESSOR/TAPE 2 RECORD OUT - Connect to your tape deck's input (RECORD) or to your A/V processor's Tape or Line inputs.
- 10 PROCESSOR/TAPE 2 PLAY IN - Connect to your tape deck's output (PLAY) or to your A/V processor's Tape or Line outputs.
- If you have only one tape deck connect it to the TAPE 1 sockets.

11 TAPE 1 RECORD OUT - Connect to your tape deck's input (RECORD).

12 TAPE 1 PLAY IN - Connect to your tape deck's output (PLAY).

13 TUNER - For connecting your radio tuner.

14 A/V - Suitable for connecting an Audio-Visual product such as a VCR, Laserdisc player or Nicam tuner.

15 CD - For connecting your CD player or DAC (digital to analogue convertor).

16 AUX - For connecting any unit with a line level output, eg. tape deck, tuner etc.

- PHONO OPTION - **Please note:** The phono inputs are on a separate plug-in module which your Arcam dealer or distributor can supply and fit. This module is compatible with most high output moving coil and moving magnet cartridges (MM) and low output moving coil cartridges (MC). MM or MC is selected via an internal switch. Your cartridge type should be specified when the module is fitted.

18 MM - For connecting a turntable fitted with a high output moving coil or a moving magnet (MM) cartridge.

19 MC - For connecting a turntable fitted with a low output moving coil (MC) cartridge.

20 GROUND TERMINAL - For connecting your turntable's earth lead (if fitted).

OPERATION OF THE ALPHA 9 INTEGRATED AMPLIFIER

- 17 NORMAL/ A/V READY SWITCH - (This switch is found on the rear panel.)
With the switch set to NORMAL the unit functions as a standard amplifier. For use with an A/V decoder with its own volume control, such as the Arcam Xeta 2, set the switch to 'A/V READY'. This bypasses the Alpha 9's volume control when 'PROCESSOR/TAPE 2' input is selected, to provide a fixed gain stereo amplifier. The volume control and MUTE cannot be operated by remote in this situation.

CAUTION: Do not set the switch to A/V READY if you have a cassette deck connected to the PROCESSOR/TAPE 2 input.

This will bypass the volume control when you push the PROCESSOR/ TAPE 2 button in and send the signal straight into the power amplifier section. This could give an extremely high sound output sufficient to damage your loudspeakers.

- 21 LISTEN SELECTOR - Selects the input you wish to listen to. This signal also goes to the TAPE 2 output sockets for recording onto a cassette deck or for external processing. The selector can also be operated by remote control. (See Remote Control Functions).

22 RECORD SELECTOR - Selects the input you wish to record onto TAPE 1. This operates independently of the LISTEN function. Alternatively this switch can also be used as a simple 'second zone' selector, routing a chosen source signal at line level to a second amplifier operating in another room in the house.

23 VOLUME - Adjusts the volume level of the loudspeakers and headphones.

Note that with the volume at minimum it may be possible to still hear music very faintly. This is normal. The VOLUME control is motorised and can be controlled remotely with the supplied remote control handset (see Remote Control functions for more details).

24 PROCESSOR/TAPE 2- This is a tape loop to permit you to monitor a recording made on a 3 head cassette deck. It can also be used to enable line inputs to be sent to an external surround decoder such as the Arcam Xeta 2 for processing, before being routed back to the amplifier. For playback from a cassette deck or to reconnect the output from an A/V processor attached to TAPE 2 press the button in.

With the button out the 'loop' is taken out of circuit, so that the input signal chosen with the LISTEN selector is played through the amplifier.

Note: PROCESSOR/TAPE 2 is not remote controllable.

25 DIRECT - When this button is pushed in it bypasses the bass, treble and balance controls. This affects all inputs, and will generally give a small improvement in sound quality and a useful reduction in the level of background hiss.

26 BASS - Rotate clockwise to boost the bass response and anti-clockwise to cut the bass response. For a flat response leave in the central 'click' position.

27 TREBLE - Rotate clockwise to boost the treble response and anti-clockwise to cut the treble response. For a flat response leave in the central 'click' position.

- The range of the tone controls has been deliberately limited to approximately +/- 8dB at the frequency extremes.

28 BALANCE - Rotate clockwise or anti-clockwise to move the position of the stereo image. This may be necessary if it is not possible to sit centrally between the speakers. In normal use leave in the central 'click' position.

29 SP1 - Selects or defeats the main pair of speakers. Push the button in to select.

30 SP2 - Selects or defeats the secondary pair of speakers. Push the button in to select.

Important note: If both switches are turned off then the amplifier will appear not to be functioning, as all speakers will be switched off!

31 HEADPHONES SOCKET - Accepts headphones rated between 8 ohms and 2kohms fitted with a 6.3mm stereo jack plug. If your headphones are fitted with a different plug contact your dealer for a suitable adaptor. If you wish to listen on headphones only, use SP1 and SP2 (if necessary) to mute the speakers.

- The headphone socket is always switched on, irrespective of the positions of switches **29** and **30**.

32 POWER - Switches the unit on and off.

33 POWER LED - The LED above the POWER switch will initially glow amber. After a few seconds, it will glow green. When the LED glows amber, the speakers are disconnected and an internal protection circuit is activated or the unit has been muted by use of the remote control. If this LED glows amber during normal use it may be due to the amplifier overheating or an output overload. Check the amplifier is properly ventilated.

Switch the amplifier off and wait for 2-3 minutes before switching on again. If the LED continues to glow amber, switch the unit off, remove all the speaker cables and switch on again. If the LED goes to green upon switch on then check the speaker and speaker cables for short circuits before reconnecting them.

If the LED continues to glow amber with no speakers connected contact your Arcam dealer.

34 REMOTE RECEIVER - The remote receiver is behind the badge in the top left hand corner of the unit. Ensure the remote receiver is not obscured or commands from the remote control handset will not be received.

TAPE RECORDING

- Both sets of tape sockets (TAPE 1 and TAPE 2) are identical in sensitivity and suitable for use with almost any type of recorder (cassette, hi-fi VCR, reel to reel, DAT, etc.)

- Use the RECORD selector to route the required signal to a cassette deck connected to the TAPE 1 RECORD OUT sockets.

- Use the LISTEN selector to route the required signal to a cassette deck connected to the TAPE 2 RECORD OUT sockets.

- RECORDING (TAPE 1): Any input signal available on the Alpha 9 may be routed to the TAPE 1 output sockets by using the RECORD selector to select the appropriate input.

Set your tape recorder into its recording mode and the selected input will be recorded.

Selecting the same input with the LISTEN selector will not affect the signal sent out to the recorder and will now enable you to listen to the signal being recorded. You may listen to another input whilst recording on TAPE 1 by use of the LISTEN selector.

If your tape recorder is a 3 head design, this will allow A-B monitoring of the actual recording while it is taking place. Switching the LISTEN switch between the original source and TAPE 1 during recording will then enable you to make a true 'before' and 'after' (A-B) comparison.

- TAPE TO TAPE DUBBING: The Alpha 9 allows two way tape dubbing (copying) from TAPE 1 to TAPE 2 or vice versa.

For example, to copy from a recorder connected to the TAPE 2 sockets to a recorder connected to TAPE 1, first switch the RECORD selector on the Alpha 9 to TAPE 2. This routes the TAPE 2 signal to TAPE 1's output.

Then set the first tape recorder into its 'record' mode and the second to 'playback' mode to enable the transfer to take place. If you wish to monitor the transfer while it is taking place switch LISTEN to TAPE 1.

To record from TAPE 1 to TAPE 2 set listen to TAPE 1. It does not matter what position the RECORD selector is in. To monitor push the PROCESSOR/TAPE 2 button in.

PRE/POWER CONNECTIONS

7 PWR AMP IN - To use your Alpha 9 just as a power amplifier, connect the output of your pre-amplifier to the PWR AMP IN sockets. The Alpha 9's internal selector switch should be set to the EXT INPUT position to disconnect the preamp stages of the unit. Contact your dealer or Arcam for more details.

Under these circumstances it has exactly the same specification and performance as an Alpha 9P power amplifier.

8 PREAMP OUT - To use your Alpha 9 as a pre-amplifier, connect the PREAMP OUT sockets to the input sockets of your power amplifier. With a power amplifier of the correct gain (e.g. An Arcam Alpha 9P or Delta 290P) this allows you to bi-amplify ("bi-amp") suitable loudspeakers, giving significant improvements in sound quality (see section on BI-WIRING/ BI-AMPING).

REMOTE CONTROL FUNCTIONS

- Your Alpha 9 amplifier is supplied with the Arcam CR35 infra-red remote control handset, which has buttons to allow the simple operation of other products. It is supplied with 2 AA batteries - ensure these are inserted correctly.
- The remote allows you to operate the Alpha 9 plus some basic functions of an Arcam (except the Alpha One CD player, which uses a different remote control language) or Philips based CD player, a remote controlled tuner (such as the Arcam Delta 280* or Alpha 8 tuner) and the Arcam Delta Black Box 500 DACC (Digital Audio Control Centre).

* Note: versions of the Delta 280 FM tuner manufactured before April 1995 will not respond to the programme up/down buttons on the CR35.

- REMOTE MODE - The Alpha 9 is factory-set to enable the Arcam CR35 or Arcam CR200 System Remote automatically to synchronise the operation of any Arcam CD player or transport, remote control tuner (and with a CR200, the Arcam Delta 100 cassette deck) with the LISTEN selector on the Alpha 9, all at the touch of a single button.

For example, using the CR35 remote, press PLAY, and the CD player will start the disc and the LISTEN switch of the Alpha 9 will select the CD input. If automatic operation is not required it can be disabled by your dealer by fitting an internal link. The LISTEN selector switch can still be operated by either remote control handset.

Note: The 'STBY', 'DISP' and 'VCR' buttons do not initiate any functions within the Alpha 9 amplifier. 'DVD' can be used to select the aux input on the Alpha 9.

- The MUTE button mutes the speaker connections and pre-amp outputs. Both tape outputs and the headphone socket remain active. In MUTE mode the power LED will turn amber until mute is disabled by either pressing MUTE again or pressing volume +/-.

Section C

ALPHA 9P POWER AMPLIFIER

Please refer to drawing inside front cover.

LOUDSPEAKER CONNECTIONS

Connect up as per instructions for the Alpha 9 integrated amplifier.

CONNECTING YOUR SOURCE COMPONENT

7 PWR AMP IN - Connect to your pre-amplifier outputs or the PREAMP OUT sockets of an Arcam Delta 290 or Alpha 9 amplifier.

8 MONO LINK - The Alpha 9P can be configured to provide two mono loudspeaker outputs from a single input. Using the U-link **9** supplied, connect the MONO LINK sockets **8** together.

Utilising one Alpha 9P per loudspeaker in this manner will allow bi-amplifying of bi-wireable loudspeakers. This is particularly beneficial for top quality stereo installations with a separate pre-amplifier, or for the left, centre and right channel loudspeakers in a five speaker Dolby Pro Logic system. Contact your Arcam dealer for more detailed information.

- **Daisy Chain** - The Alpha 9P is capable of driving further Alpha 9P amplifiers (or any other power amplifier), to drive more speakers (eg. those in other rooms or tri-amplified speakers etc). Connect the extra power amplifier inputs to the MONO LINK outputs **8** left to left, right to right.

FRONT PANEL

10, 11 SP1 and SP2 - Pressing the SP1 switch turns on the speakers connected to the SP1 (upper) set of output terminals on the rear panel. Similarly the SP2 switch turns on the speakers connected to the SP2 (lower) set of output terminals.

- Both the SP1 and SP2 switches can be turned on at the same time, provided that the combined impedance of the two pairs of speakers does not fall below 4 ohms per channel.

Important note: If both switches are turned off then the amplifier will appear not to be functioning, as all speakers will be switched off!

12 HEADPHONES SOCKET - Accepts headphones rated between 8 ohms and 2k ohms fitted with a 6.3mm stereo jack plug. If your headphones are fitted with a different plug contact your dealer for a suitable adaptor.

- The headphone socket is always switched on, irrespective of the positions of switches **10** and **11**.

13 POWER - Switches the power on and off.

- 14 POWER LED - This will initially glow amber. After a few seconds, it will glow green. When the LED glows amber, the speakers are disconnected and an internal protection circuit is activated.

- If this LED glows amber during normal use it may be due to the amplifier overheating or an output overload. Check the amplifier is properly ventilated. Switch the amplifier off and wait for 2-3 minutes before switching on again.

If the LED continues to glow amber, switch the unit off, remove all the speaker cables and switch on again. If the LED goes to green on switch on then check the speaker and speaker cables for short circuits before reconnecting them.

If the LED continues to glow amber with no speakers connected contact your dealer or Arcam.

Section D

BI-WIRING/BI-AMPING INSTRUCTIONS

Many modern loudspeakers are equipped with four connection terminals. This provides direct access to the high frequency and low frequency filter networks and associated drive units within the loudspeaker. Overall performance can be enhanced by making use of these separate connections.

WARNING: Do not make any connections to your amplifier while it is switched on and connected to the mains supply. Please check all connections thoroughly before attempting to re-connect the mains power supply. Always ensure that the volume control on your amplifier is set to a minimum before switching on.

BI-WIRING

Bi-wiring uses four conductors, one for each terminal, to enhance dramatically the performance of your loudspeakers. Bi-wiring eliminates the signal distortion arising from the low and high frequency currents interacting with one another within a single cable, as used in conventionally wired systems.

HOW TO BI-WIRE YOUR LOUDSPEAKERS

- Remove the shorting links from each of the red and black terminal pairs on the rear of your loudspeakers.
- You will need two lengths of loudspeaker cable per loudspeaker (which may be joined at the amplifier end) or a suitably terminated cable set capable of being used for bi-wiring in one length.
- Connect the cables as per diagrams, dependant on your cable wiring, ensuring correct polarity at all times. The positive (+) connections on the right loudspeaker must go to the positive (+) connections on the right channel of the amplifier and the negative (-) connections on the right loudspeaker must go to the negative (-) connections on the right channel of the amplifier etc.

BI-WIRING USING BOTH SETS OF CONNECTIONS ON AMP

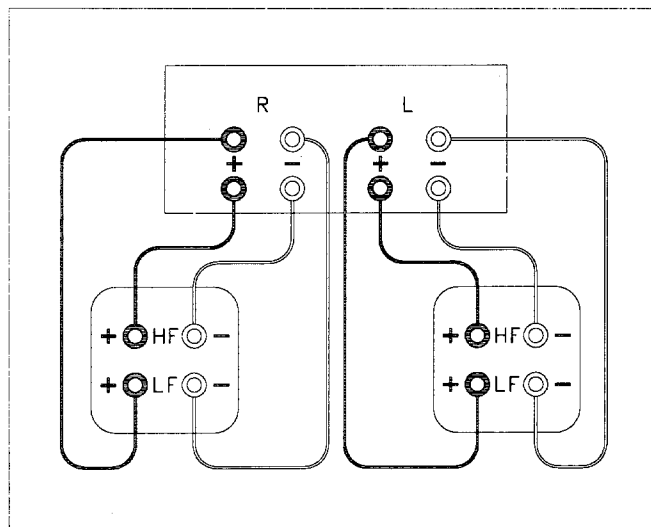

BI-WIRING USING ONE SET OF CONNECTIONS ON AMP

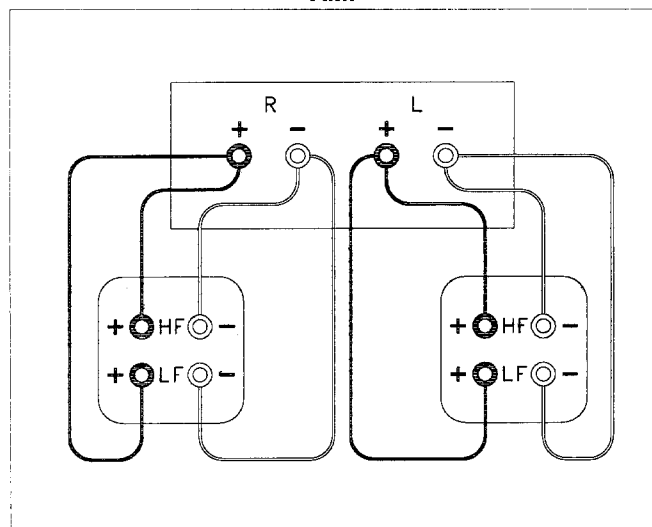

BI-AMPING

The performance of your system can be further enhanced over that achieved with bi-wiring, by extending the same principal one stage further to include separate amplification for the low and high frequency speaker drive units as well as separate loudspeaker cables. This is known as bi-amplifying, or bi-amping for short.

To implement bi-amping therefore requires four amplification channels. In practice this is done by using two stereo amplifiers; when one of these is an integrated amplifier it is best to use this drive the high frequency (HF) units whilst the outboard power amplifier is used to drive the low frequency (LF) units.

We recommend that you use identical amplifiers to avoid potential imbalances in sonic performance and sensitivities. The Alpha 9/9P combination is ideal, as is the Delta 290/290P. It is however possible to mix the Alpha 9 and Delta 290 range of amplifiers.

HOW TO SET UP A BI-AMPED SYSTEM

1. Remove the shorting links from each of the red and black terminal pairs on the rear of your loudspeakers.

THIS IS ESSENTIAL OR DAMAGE TO YOUR AMPLIFIERS MAY RESULT WHICH IS NOT COVERED UNDER WARRANTY.

BI-AMPING YOUR LOUDSPEAKERS

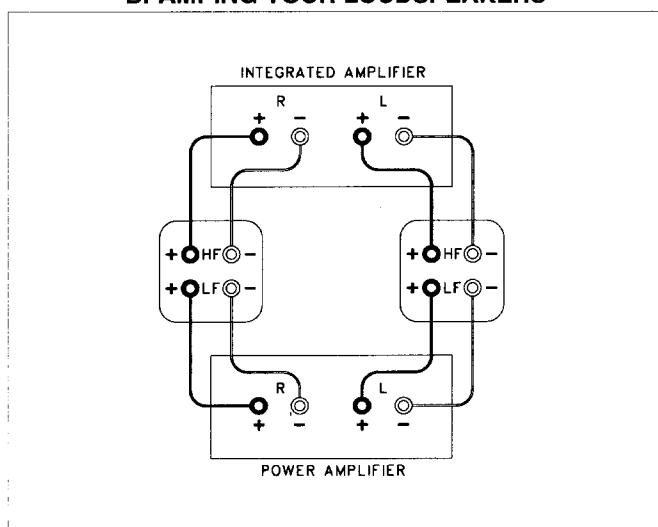

2. You will need two lengths of loudspeaker cable (or a suitably terminated cable capable of being used for bi-wiring in one length) and one stereo amplifier per frequency band.
3. Connect your system as per the diagram opposite ensuring correct polarity at all times. The positive (+) connections on the loudspeaker must go to the positive (+) connections on the amplifier and the negative (-) connections on the right loudspeaker must go to the negative (-) connections on the right channel of the amplifier etc. You also need to make a connection from the preamp out sockets of your integrated amplifier, or preamplifier, to the power amp in sockets of the power amp.

ADDING AN ALPHA 9P TO AN EXISTING ALPHA 9 INTEGRATED AMPLIFIER

If you are using an Alpha 9, an Alpha 9P can be added to bi-amplify a pair of bi-wireable loudspeakers. This will reap substantial improvements in sound quality if the following advice is observed.

- Always switch on the Alpha 9 and allow it to stabilise (indicator light turns green) before switching on the Alpha 9P.
 - The Alpha 9 and Alpha 9P power amplifier are placed on separate shelves. Stacking the units on top of each other will reduce the sound quality slightly. It will also reduce ventilation and consequently the continuous power handling capability.
 - The existing Alpha 9 should be used to drive the loudspeakers' HF (high frequency) units. The new Alpha 9P is utilised for the LF (bass) drivers, as shown in the wiring diagram below.
 - At the end of a listening session the Alpha 9P should always be turned off first.
 - High quality interconnect cables should be used between the Alpha 9 and Alpha 9P.
 - The use of high quality interconnect and speaker cables in your system is essential to obtain good sound quality. Contact your dealer or Arcam for further details and recommendations.
- Note: The second set of speaker terminals (SP2) on both units can be used to drive extra loudspeakers in other rooms provided the impedance of these are 8 ohms or more.
- WARNING - Ensure that the TERMINAL LINKS ARE REMOVED on the loudspeakers before switching on the amplifiers. Failure to do this could cause damage to one or both amplifiers and this is not covered under the warranty.**

GUARANTEE FOR UK SALES

This equipment is guaranteed for two years from the date of purchase (parts and labour only), provided that it was originally purchased from an authorised dealer under a consumer sale agreement. (The words "consumer sale" shall be construed in accordance with Section 15 of the Supply Of Goods [Implied Terms] Act 1973).

The manufacturer can accept no responsibility for defects arising from accident, misuse, abuse, wear and tear, neglect or through unauthorised adjustment and/or repair, neither can they accept responsibility for damage or loss occurring during transit to or from the person claiming under this guarantee.

This guarantee is applicable within the UK only. It is transferable to subsequent purchasers, but the liability of the manufacturer is limited to the cost of repair of the defective parts and under no circumstances extends to consequential loss or damage.

CLAIMS UNDER THIS GUARANTEE

This equipment should be packed in the original packing and returned to the dealer from whom it was purchased, or failing this, directly to Arcam. It should be sent carriage prepaid by a reputable carrier - NOT by post. No responsibility can be accepted for the unit whilst in transit to the factory, or an agent, and customers are therefore advised to insure the unit against loss or damage whilst in transit.

If the original packing is not available, replacement packing can be purchased from Arcam.

DO NOT CONSIGN THE EQUIPMENT TO ARCAM UNLESS YOU HAVE BEEN SPECIFICALLY REQUESTED TO DO SO BY THE CUSTOMER SUPPORT DEPARTMENT.

DO NOT UNDER ANY CIRCUMSTANCES ATTEMPT TO DISASSEMBLE THE EQUIPMENT BEFORE DESPATCH.

You can contact the manufacturer at the following address:

ARCAM Customer Support Department,
Pembroke Avenue,
Denny Industrial Centre,
Waterbeach,
Cambridge,
CB5 9PB,
England.

Telephone: +44 (0)1223 203203

Fax: +44 (0)1223 863384

e-mail: custserv@arcam.co.uk

You should state clearly your name and address, the date and place of purchase together with a brief description of the fault.

In the event of equipment being returned which, after having been tested, is found to comply with the published specification, the manufacturer reserves the right to charge a reasonable fee for testing the equipment and for the return carriage.

THIS GUARANTEE IN NO WAY VARIES OR REMOVES A PURCHASER'S STATUTORY RIGHTS.

GUARANTEE FOR SALES IN THE EUROPEAN ECONOMIC AREA (EEA)

This unit is covered by a European Economic Area warranty, provided to you under the terms of Article 85 of the Treaty of Rome 1957.

This entitles you to have the unit repaired free of charge, during the first two years after purchase, at any authorised Arcam distributor within the EEA, provided that it was purchased from an authorised ARCAM dealer or distributor within the EEA.

The manufacturer can accept no responsibility for defects arising from accident, misuse, abuse, wear and tear, neglect or through unauthorised adjustment and/or repair, neither can they accept responsibility for damage or loss occurring during transit to or from the person claiming under this guarantee.

Countries of the European Economic Area are: Belgium, Holland, Norway, Iceland, Lichtenstein, Luxembourg, Greece, Germany, France, Spain, Portugal, Eire, Italy, Austria, Denmark, Sweden, Great Britain, Finland and Switzerland. This includes the Canary Islands, the Channel Islands, the Isle of Man, Corsica and Sardinia.

This warranty remains in force for two years from the date of purchase as long as the unit remains in free circulation. Units exported from the EEA and subsequently re-imported are not subject to this warranty.

CLAIMS UNDER GUARANTEE

This equipment should be packed in the original packing and returned to the dealer from whom it was purchased, or failing this, directly to the Arcam distributor in the country of residence. It should be sent carriage prepaid by a reputable carrier - NOT by post. No responsibility can be accepted for the unit whilst in transit to the dealer or distributor and customers are therefore advised to insure the unit against loss or damage whilst in transit.

For further details contact Arcam at:

ARCAM Customer Support Department, Pembroke Avenue, Denny Industrial
Centre, Waterbeach, Cambridge, CB5 9PB, England.
Telephone: +44 (0) 1223 203203 Fax: +44 (0) 1223 863384
e-mail: custserv@arcam.co.uk

GUARANTEE FOR SALES IN THE REST OF THE WORLD

This equipment is guaranteed in the country of purchase only, provided that it was purchased from an authorised ARCAM dealer or distributor.

The manufacturer can accept no responsibility for defects arising from accident, misuse, abuse, wear and tear, neglect or through unauthorised adjustment and/or repair, neither can they accept responsibility for damage or loss occurring during transit to or from the person claiming under this guarantee.

Full details of the guarantee can be obtained from the distributor in the country of purchase.

For your convenience a list of Arcam distributors is included in the enclosed 'After Sales Care Program' leaflet. For any countries not listed please contact Arcam Customer Support directly.

CLAIMS UNDER GUARANTEE

This equipment should be packed in the original packing and returned to the dealer from whom it was purchased, or failing this, directly to the Arcam distributor in the country of purchase. It should be sent carriage prepaid by a reputable carrier - NOT by post. No responsibility can be accepted for the unit whilst in transit to the dealer or distributor and customers are therefore advised to insure the unit against loss or damage whilst in transit.

TECHNICAL SPECIFICATIONS

ALPHA 9 INTEGRATED AMPLIFIER

Output power (20Hz-20kHz at 0.5%THD)	70W, both channels into 8Ω 90W, single channel into 8Ω, 1kHz 140W, single channel into 4Ω, 1kHz
Harmonic Distortion, 60W, 8Ω at 1kHz	0.02% typical
Peak current rating	± 18 amps
Tone controls (typical variation)	± 8dB at 50Hz and 10kHz
L/R Crosstalk	-65dB at 1kHz

INPUTS

Line inputs:	Sensitivity 160mV
Noise (CCIR) ref. rated power	-98dB typical ("DIRECT" IN) -90dB typical ("DIRECT" OUT)
Input impedance	5kΩ
Overload margin	>50dB
A/V loop input (A/V mode)	Sensitivity 670mV
Input impedance	5kΩ
Power amp in	Sensitivity 650mV
Input impedance	7.5kΩ
Phono board (if fitted):	Sensitivity 2.6mV MM, 260μV MC
Noise (CCIR) ref. rated power	-79dB MM, -73dB MC
Input impedance	47kΩ MM, 300Ω MC
Overload margin	35dB

OUTPUTS

Preamplifier Output	
Nominal output level	800mV
Maximum output level	8V
Output impedance	100Ω
Tape/ AUX outputs:	
Output impedance	100Ω
Headphones:	
Maximum output level into 600Ω	8V
Output impedance	100Ω
Mains voltage	230V/115V ±12%
Power consumption(max)	550VA
Dimensions W/D/H mm.	430x330x110
Weight nett	6.1kg (packed 7.6kg)
Supplied accessories	Mains lead CR35 Remote Handset (inc. batteries)

ALPHA 9P POWER AMPLIFIER

Output power (20Hz-20kHz at 0.5%THD)	70W, both channels, 8Ω 90W, single channel, 8Ω, 1kHz 140W, single channel, 4Ω, 1kHz
Harmonic Distortion, 60W, 8Ω at 1kHz	0.02% typical
Peak current rating	± 18 amps
Input impedance	7.5kΩ
Input sensitivity	650mV for 70W/ 8Ω
Gain (1kHz)	31.3dB ± 0.2dB
Frequency response	10Hz-20kHz ± 0.5dB
Noise (CCIR) ref. rated power	-100dB
Mains voltage	230V/115V ±12%
Power consumption(max)	550VA
Size W/D/H mm.	430x320x110
Weight nett	5.8kg (packed 7.2kg)
Supplied accessories	Mains lead

ARCAM

Pembroke Avenue, Waterbeach,
Cambridge, CB5 9PB, England.
Telephone: +44 (0) 1223 203203
Fax: +44 (0) 1223 863384
e-mail custserv@arcam.co.uk

Free Manuals Download Website

<http://myh66.com>

<http://usermanuals.us>

<http://www.somanuals.com>

<http://www.4manuals.cc>

<http://www.manual-lib.com>

<http://www.404manual.com>

<http://www.luxmanual.com>

<http://aubethermostatmanual.com>

Golf course search by state

<http://golfingnear.com>

Email search by domain

<http://emailbydomain.com>

Auto manuals search

<http://auto.somanuals.com>

TV manuals search

<http://tv.somanuals.com>