

Model T70.1 PBM

High Performance Powered Subwoofer



 Atlantic Technology®
INNOVATIVE HOME THEATER

343 Vanderbilt Avenue Norwood, MA 02062 (781) 762-6300 www.atlantictechnology.com

Instruction Manual

MODEL T70.1 PBM

High Performance Powered Subwoofer



Congratulations on your purchase of an Atlantic Technology T70.1 PBM powered subwoofer. With proper care, your new subwoofer will provide many years of trouble-free performance.

The T70.1 PBM is capable of delivering very high output levels and wide dynamic range. When properly placed it will provide smooth in-room bass response down to approximately 25Hz, with a peak SPL of 103dB (1500 cubic foot space).

The built-in proprietary high-current amplifier is conservatively rated at 125 watts RMS. This amplifier, coupled with a massive 10" long-throw treated cellulose pulp woofer in a sealed enclosure, generates musically accurate deep bass with a minimum of distortion.

Your Atlantic Technology powered subwoofer will smoothly integrate with virtually all other brands of loudspeakers on the market as all its internal electronics have been designed to maintain optimum signal integrity. From the premium quality amplifier to the clearly marked controls, this is one of the most versatile high performance subwoofers you can buy. An added benefit is its relatively compact size and straight forward design.

Features

Your Atlantic Technology powered subwoofer has been engineered using the latest technology and finest components available. It features:

- **A long-throw 10" driver with vented motor structure and 2" high temperature, 4-layer voice coil**
This powerful driver has a very stiff treated cellulose pulp cone that acts as an almost perfect piston throughout its operating range. Its massive magnetic motor assembly and high temperature component parts deliver high performance and exceptional reliability.
- **A sealed enclosure for low distortion and deep bass output**
Sealed enclosure designs are inherently low in distortion and naturally deliver deep, smooth bass response with a gradual and predictable roll-off below resonance. As with all Atlantic Technology subwoofers, we have paid inordinate attention to giving you accurate musical bass reproduction along with terrific special effects.
- **A linear power high current Class A/B amplifier conservatively rated at 125 watts RMS**
The T70.1 PBM's custom-designed discrete amplifier has been precision matched and equalized to its 10" driver. It exerts accurate and powerful control over the driver for the best performance possible.
- **A useful in room working frequency range of 25Hz to 150Hz**
- **A continuously adjustable 24dB/octave crossover with a range of 60 Hz to 150Hz**
This sophisticated crossover's steep upper end roll-off slope of 24 dB per octave allows for exceptional integration with most any brand or type of satellite speaker on the market. In particular, the 24dB/octave design makes the T70.1 PBM ideal for use with compact, bass restricted satellite speakers.

Important Note: If you are using a surround receiver/processor that includes its own filtered subwoofer output we recommend that you set the crossover switch on the T70.1 PBM to Bypass.

- Two line inputs, two line outputs**
 The outputs allow daisy chaining of multiple subwoofers, or can act as a return path back to the processor.
- Two high level inputs, two high level outputs**
 These let you connect the subwoofer to your amplifier using the amplifier's speaker outputs. The speaker outputs may be connected to the left and right front satellite speakers.

Figure 1:
Typical amplifier panel and controls for Model T70.1 PBM. Your amplifier may differ from this illustration.

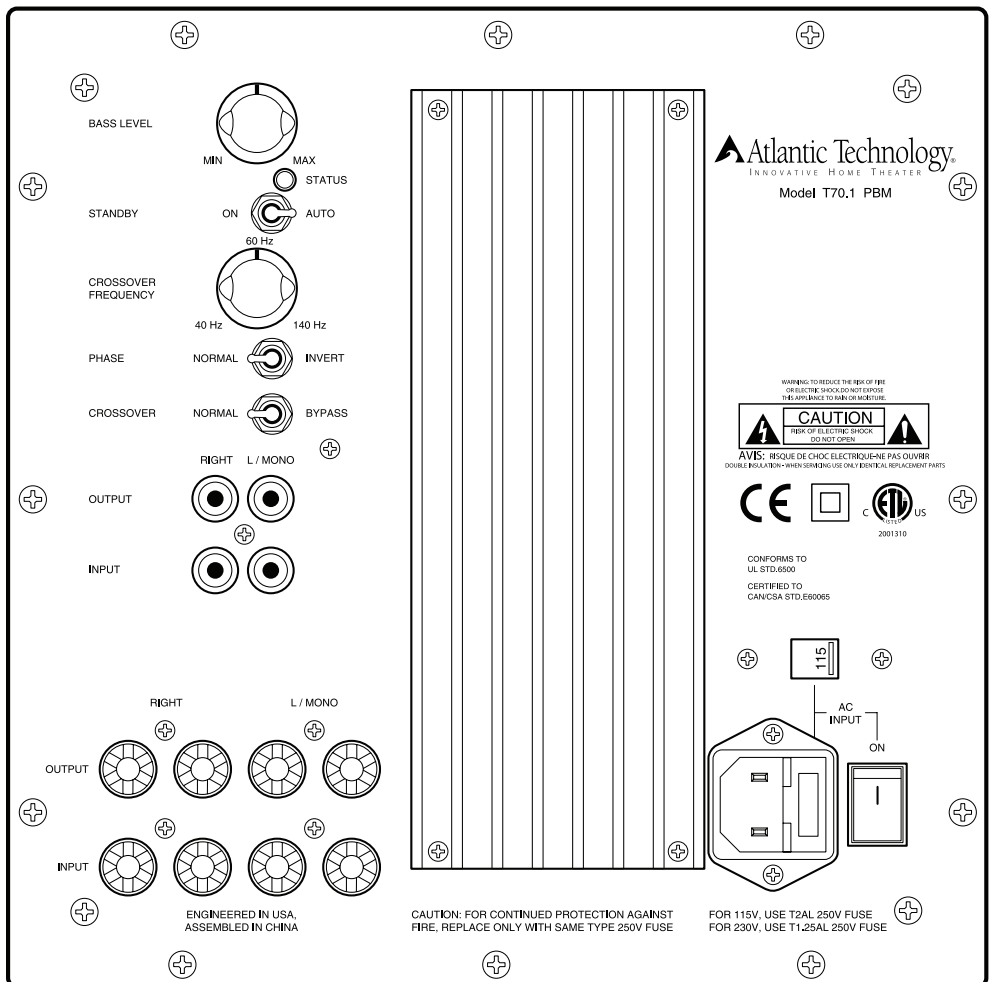

- **A Phase Invert switch (Normal/Invert)**
This switch allows precise acoustic matching with speaker systems whose output may be phase reversed. This switch also allows you to compensate for unusual room acoustics that occur when a woofer is physically separated from the midrange/high frequency units. Be sure to try the Phase switch in both positions when you set up the T70.1 PBM. Even if you just change the built-in crossover settings it's a good idea to try the Phase switch in both positions, since the crossover control and the Phase switch acoustically interact with each other.
- **A rear panel mounted level control**
- **Automatic standby operation**
Automatic standby features automatic signal sensing turn on and a 7-12 minute turn-off delay.
- **Designed and built to meet all CSA and CE safety requirements**

Connecting Your Subwoofer

The Atlantic Technology System T70.1 PBM Powered Subwoofer is simple to hook up, offering several connection methods for maximum flexibility. Study the system diagrams starting on the next page. Once you have found the example which most closely matches your system, hook up your subwoofer(s) as shown in that diagram.

Low-Level Connection

If you have purchased the entire System T70, we suggest using the low-level (RCA jack) subwoofer line out or preamp output if your receiver/processor has one. Simply connect your subwoofer with high quality shielded cables as shown in the diagrams. Use the diagram that best suits your connection requirements.

Using the Low-level Output

If desired, you can run a line level signal through the T70.1 PBM and out to another unit. This way you can add an additional subwoofer with minimal additional wiring. The signal that comes out of the Output jacks is identical to the input signal.

High-Level Connection

Alternately, you may use the high-level (speaker) inputs. We recommend that you connect your new T70.1 PBM Powered Subwoofer(s) using high quality wire of 16 gauge or larger. There are many respected manufacturers in the audio industry that specialize in speaker wire and interconnect cables suitable for your new system. Please consult your audio/video dealer for more specific information.

High-level Output

If desired, you can run a high level signal into the T70.1 PBM and directly out to the left and right front speakers. This method is primarily intended for systems without a built-in crossover or a dedicated subwoofer output. The signal that comes from the High-level Output jacks is identical to the input signal.

Warning: *To prevent risk of electrical shock or damage to your equipment, always unplug all component AC cords before proceeding with speaker and component connections! The last step in wiring your system should be plugging in the AC cords!*

**Example 1:
Subwoofer
Line Out/
Low Level In**

When using this connection method, please see the Important Note on page 3.

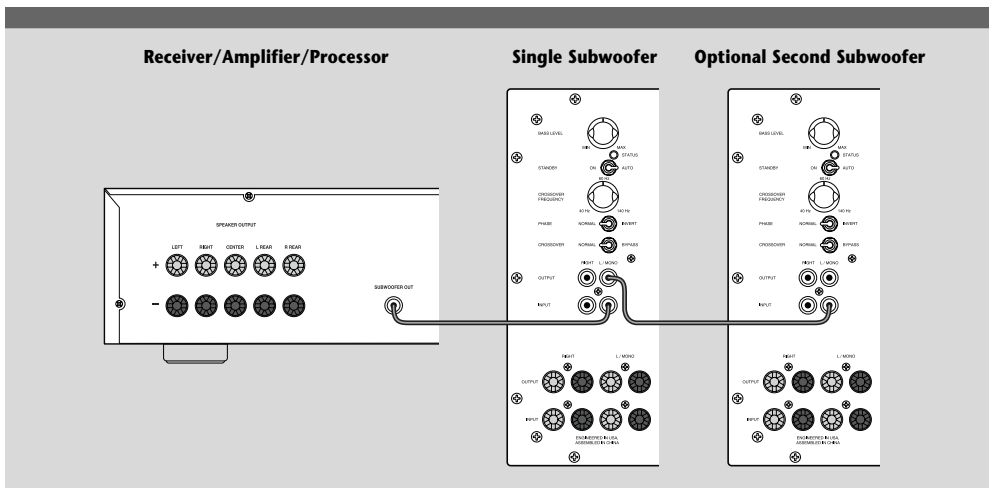

**Example 2:
Preamp Line
Out/Low
Level In for
1 Subwoofer**

This arrangement is for owners of stereo receivers/amplifiers with Preamp outputs. If your receiver/amplifier uses jumper links between the Pre-out and Main In, then you must remove them and use option 1 or 2. If your receiver/amplifier uses a switch instead of jumpers, then use option 3.

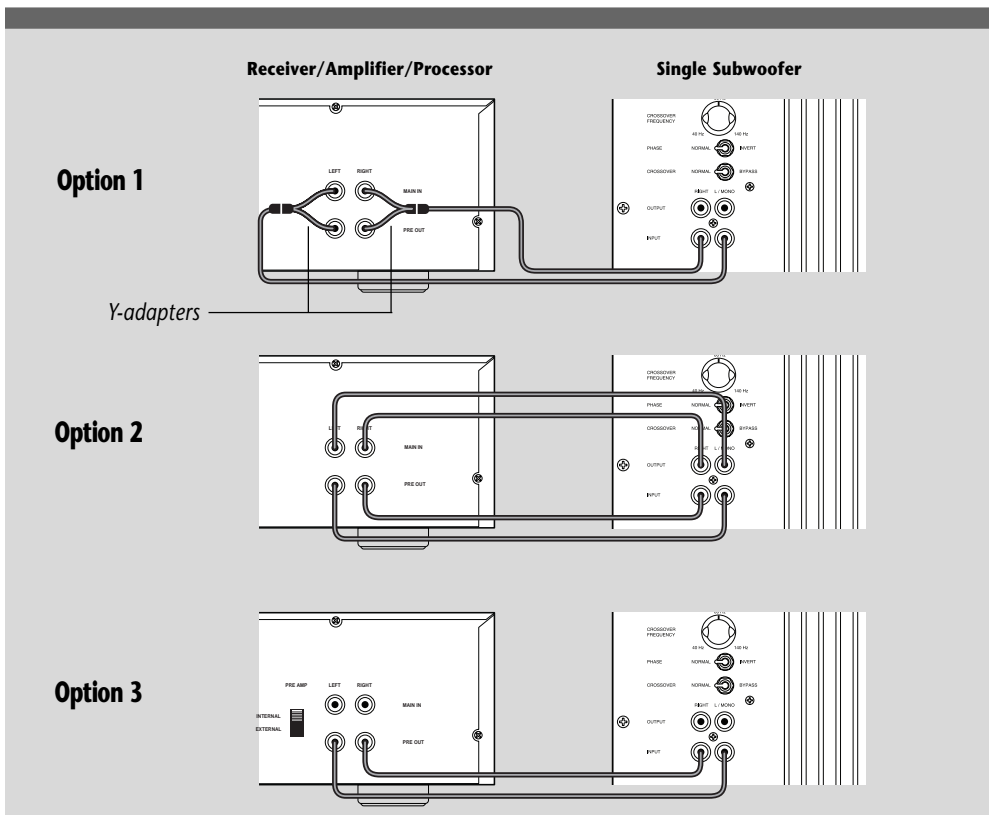

Example 3: Preamp Line Out/Low Level In for Stereo Subwoofers

Note that the L/MONO input is used on both subwoofers. Instead of Y-adapters, you may also use the outputs to connect back to the Main Inputs as shown in Option 2 of Example 2.

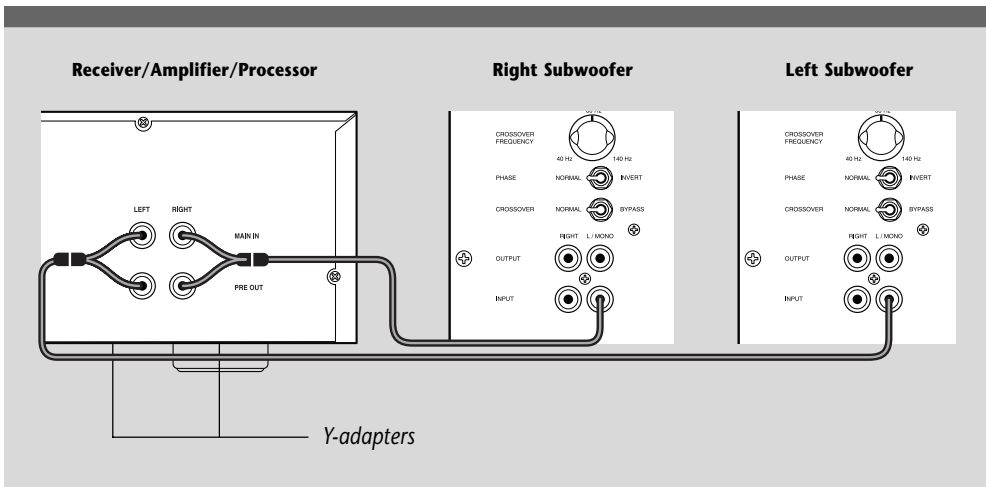

Example 4: Speaker Out/High Level In for 1 Subwoofer

This is the most common method for connecting a subwoofer to a system without a dedicated subwoofer line out or Preamp outputs. The signal that comes from the High-level Output jacks is identical to the input signal.

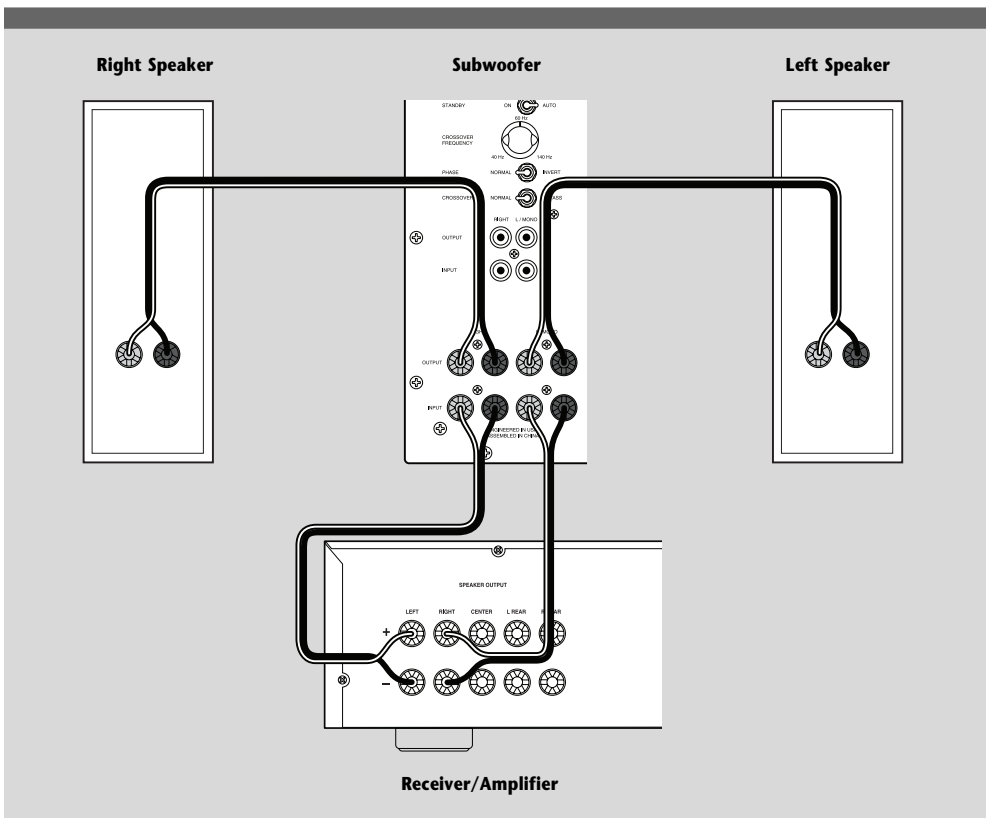

Example 5: Speaker Out/ High Level In for Stereo Subwoofers

This is the most common method for connecting 2 subwoofers to a system without a dedicated subwoofer line out or Preamp outputs. Note that the L/MONO High Level input is used on both left and right subwoofers.

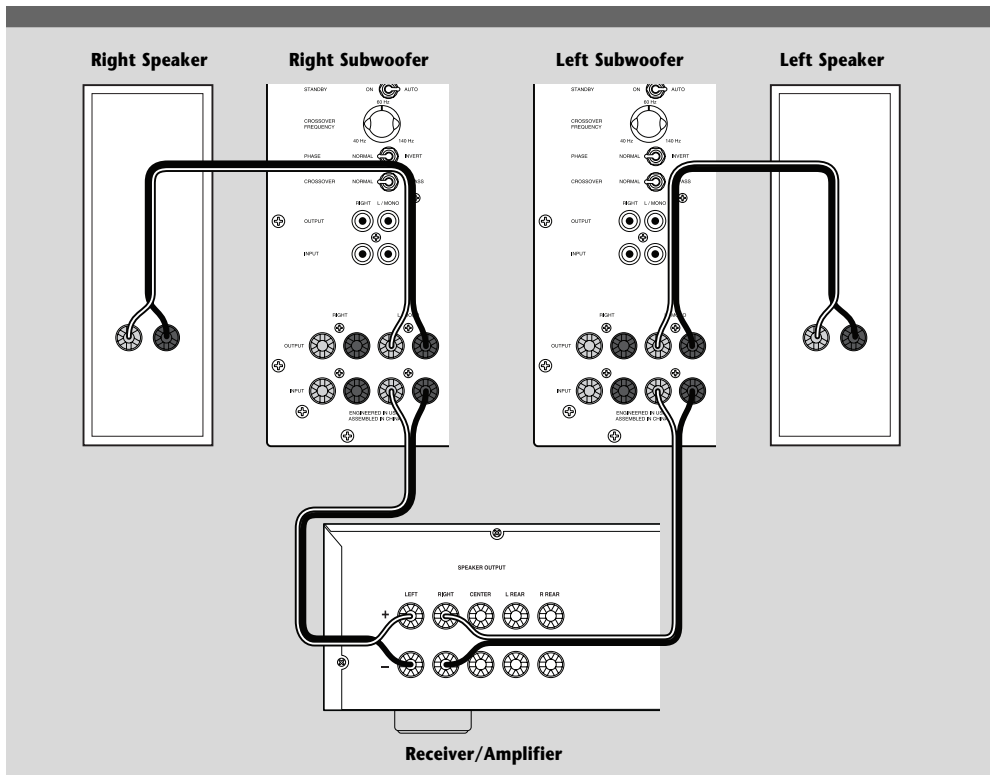

You can connect to the High-level inputs by removing 1/2" of insulation from each wire end, twisting the strands of wire together and placing the wire into the appropriate binding post on the rear of the woofer as illustrated. Be careful that no stray strands of wire touch across connections.

It is important to observe polarity while making speaker connections: red (+) terminals on the amplifier to red (+) on the speaker, black (-) on the amplifier to black (-) on the speaker. Look carefully at the wires you are using and note that one of the wires in each pair will be marked by either the conductor color, printing on the wire jacket, a ridge on one side of the wire jacket, or a thread intertwined with the wire strands. By convention, the marked wire is connected to the red (+) terminal.

Power Connection

Connect the power cord to an AC outlet only after making all other connections to the subwoofer. This will avoid any chance of accidentally activating the subwoofer while wiring. Atlantic Technology **does not recommend** plugging the subwoofer into the switched outlet of an amplifier, preamplifier, or receiver. The power demands of the subwoofer amplifier may exceed the power rating of the switched outlet and may damage the equipment.

The T70.1 PBM is totally automatic in its operation. The automatic on/off circuitry will only activate the subwoofer in the presence of an audio signal from your audio/video system. After 7-12 minutes

with no signal detected from the rest of the system, the amplifier will shut itself off and go into standby mode. Power consumption in the standby mode is negligible. Standby operation can be completely bypassed by placing the “Auto” switch in the “On” position. In this mode, the subwoofer will be controlled by the position of the Main Power switch.

Placement and Operation

Generally speaking, the best location for your new Subwoofer will be in the front of the room, in or close to a corner (Figure 2). Every room has its own unique sound characteristics, and flexibility in the exact placement of the subwoofer is always desirable. The closer the subwoofer is placed to a wall and especially a corner, the more and deeper the bass response you will hear. However, in some rooms, corner placement can produce too much bass or a “one note” boomy effect. Under such circumstances the subwoofer may work better away from the wall or corner. You should experiment to find the best position in your room.

Figure 2:
Typical arrangement for a single subwoofer in a home theater.

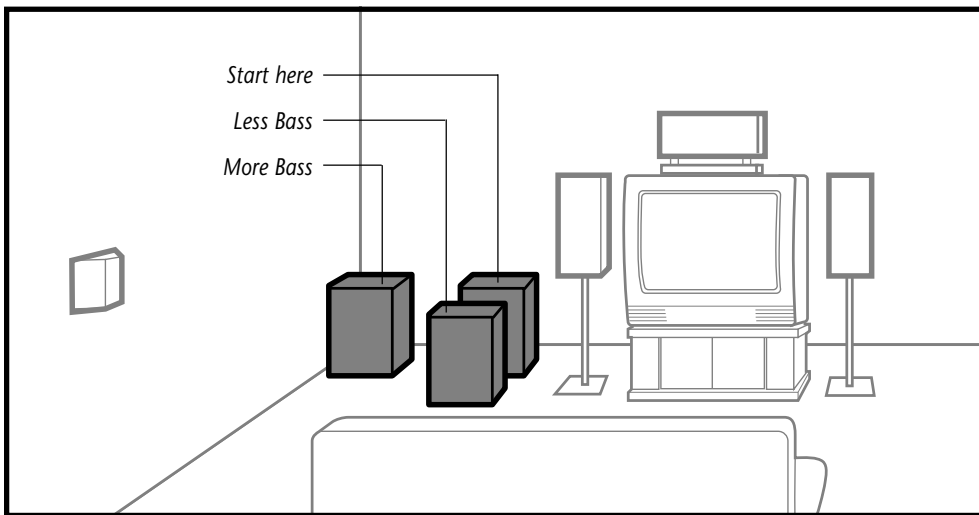

Helpful Hint: A particularly useful experiment is to place the subwoofer right at the prime listening position (move that couch or chair out of the way and put the sub in its place). Then play something with lots of good bass (preferably music), and walk around the room, listening to the subwoofer's response. When you locate an area that has ample amounts of well defined bass you have found a good potential place to locate the sub.

Dual Subwoofer Placement

When two subwoofers are used you may wish to place them asymmetrically; that is, in slightly different positions in the room (Figure 3). This will reduce common mode room resonances that typically occur with symmetrically placed subwoofers. Another good option is to place the subwoofers in the same corner. Several tests have shown this to be a viable means of producing smooth bass response in many rooms.

Figure 3:
*Assymetrical
 arrangement for
 2 subwoofers in
 a home theater,
 for example, one
 closer to a corner
 than the other.*

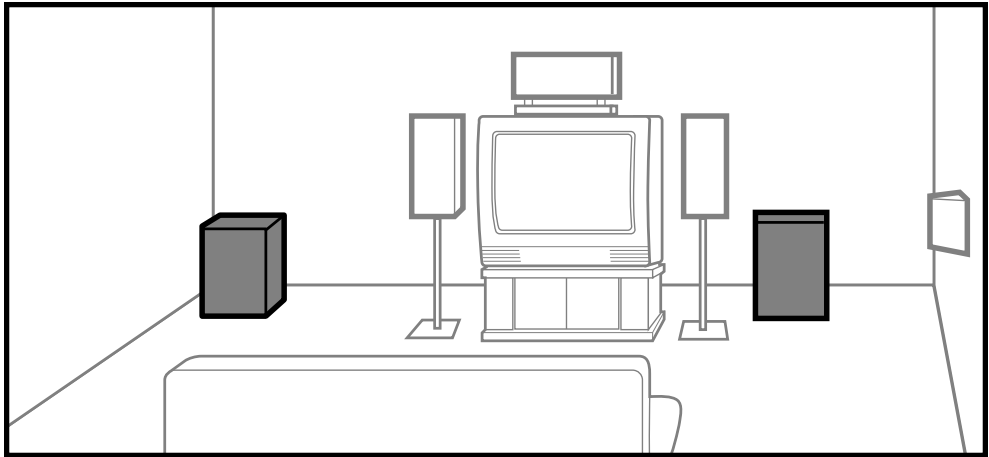

Subwoofer Tuning Using the Variable Level Control

Assuming that you do not have access to a Sound Pressure Level meter for system set up, start your listening with the subwoofer crossover control set at approximately two-thirds of its range (which corresponds to approximately 100Hz), the phase switch set to normal, and the variable level control set to the bottom of its range (fully counterclockwise facing the back of the woofer). Play some music that you know has good bass content, and turn the level control up until you just start to hear the subwoofer working. Now, from your normal listening position, determine whether the subwoofer is playing loudly enough and filling in the bass frequencies of the music evenly. If adjustment is necessary, start by changing the setting of the rear mounted level control to compensate.

If the bass seems too heavy, move the subwoofer away from the wall/corner. If the bass seems too thin, move the subwoofer closer to the wall/corner. Small differences in positioning can make big differences in bass response. When you find a position that seems to work well, have someone switch the phase switch between its two settings, while you're in the prime listening position. Pay particular attention to the transition from the subwoofer to the satellites.

Sometimes people prefer more bass impact for movies than sounds natural when reproducing music. You may wish to determine both a video level and an audio level if you find yourself falling into this camp. Remember however, the most common error people make when setting up their system is to play the subwoofer (and surround speakers) too loudly. Of course, the Bass Police will not arrest you for this act. But should you desire the most accurate overall reproduction, a well balanced sound from deepest bass to highest treble is the best way to get it.

Using the Crossover Control

When used with the complete T70.1 system, the T70.1 PBM crossover control should be set at two-thirds of its range as stated above. The goal is to optimize the performance of the system by ensuring that the subwoofer and satellites produce a cohesive and well integrated sound "picture." The low frequency response of the T70.1 satellites has been optimized to work with approximately a 100Hz crossover point. This provides maximum performance and the smoothest integration with the subwoofer.

Higher crossover frequencies pass more bass but can sound boomy and may be more easily localized to the subwoofer. Higher crossover frequencies may be suitable, however, when using very small satellites that have no real low frequency performance. Settings lower than 90Hz should be employed if you are using full range speakers that have extended bass response. This way, the subwoofer will only reproduce the very lowest bass frequencies that are in the range where the large main speakers begin to roll off. It's generally undesirable to have the main speakers and the subwoofer overlap too much. Larger speakers generally require a lower crossover frequency, smaller speakers generally a higher crossover frequency. Consult the manufacturer's specified low frequency response for your main speakers to determine the appropriate setting on the subwoofer. In the end, however, a little time spent experimenting will generally result in dramatically better bass response.

The Phase Invert Control

A subwoofer operating out of phase with the rest of the system won't provide optimum low frequency performance. Also, the correct subwoofer phase can enhance room acoustics. Since there is some variation in the industry regarding phase, and no standards have been established, a switch that will reverse the phase of the subwoofer is provided on the amplifier panel. Listen to a monaural musical source with strong bass content. (For example, you can use the mono switch on an FM tuner or preamp, or use a Y-connector on the outputs of one of your source components to get a mono signal.) Have someone experiment with the position of the phase switch to get the most extended bass while you're sitting in the prime listening position. It should be obvious which is the correct setting. In particular, there will be a smoother more integrated transition between the satellites and the subwoofer when they are properly phased.

A Word About Bass, Center Channel Modes, and System Set Up

Many Dolby Pro Logic surround processors and surround receivers feature a "Wide" and "Normal" mode for the center channel speaker. Atlantic Technology recommends that the center channel be operated in the Normal mode when using a powered subwoofer. The center channel speaker will sound more dynamic and the intelligibility of the system will generally be improved when in the Normal mode.

With discrete digital "5.1" channel systems (Dolby Digital AC-3, etc.) many controllers provide a Bass Management option, which lets you set the front and rear speakers in a limited bandwidth (Small) or full range (Large) mode. All Atlantic Technology speakers are designed to be used in the Small setting with such a controller. However, when using high level connections, the Large setting should be used.

Care and Feeding of Your Subwoofer

The T70.1 PBM is constructed from 3/4" Medium Density Fiberboard. MDF is a non-resonant material ideal for speaker system enclosures. The outside of the woofer is layered with a high quality Black Ash finished vinyl laminate. To clean the cabinet you may use a soft cloth either dry or *slightly* dampened with clean water. Be careful not to wet the cabinet or allow any water to enter the cabinet seams.

Avoid placing your speakers in direct sunlight or near a heat source that may, over time, damage the finish.

Important: *Save Your Boxes! If you can do so, save the carton, packing pieces and plastic bags that came with your subwoofer. They will be useful in case you move or have to ship your subwoofer for any reason. In any case, save all packing materials until you are certain that the system has suffered no damage in shipment. If you find such damage, either visible or internal, contact your dealer immediately for the proper return procedure.*

Model T70.1 PBM Specifications

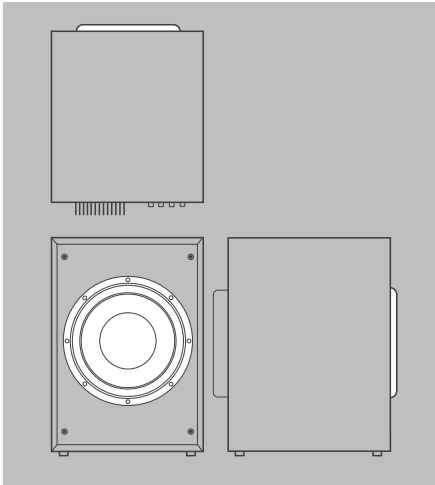

Type/Features	Powered Subwoofer with Sealed Acoustic-Suspension Enclosure 24 dB/Octave variable crossover Line-level stereo inputs and outputs High-level stereo inputs and outputs Absolute phase invert switch Auto signal sensing on/off
Driver	(1) 10" long-throw woofer, 2", 4-layer vented voice coil, vented motor system
Amplifier Power	125 Watts RMS discrete linear Class A/B power amplifier
Amplifier Distortion	<0.025%
Frequency Response	25-150 Hz ± 3 dB (in room)
Peak output (SPL)	103dB
Dimensions	11.375in x 16.5in x 14.9in; 290mm x 420mm x 380mm
Weight	37.5lbs.; 17kg.

Specifications are those in effect at the time of printing. Atlantic Technology reserves the right to change specifications or designs at any time without notice. Dolby Digital, AC-3, Dolby Stereo and Dolby Pro Logic are trademarks of Dolby Laboratories Licensing Corporation. DTS is a registered trademark of DTS Technology.

Subwoofer Troubleshooting Guide

Once your subwoofer is set up, you should have many years of maintenance free enjoyment from your system. However, if you should encounter a problem, refer to the following guide to help find the solution. If the problem persists, please contact your local authorized Atlantic Technology dealer.

Problem	Possible Cause	Possible Solution
No bass output	AC power cord unplugged or plugged into a non-working outlet. Input cables not securely connected or defective.	Plug into a working outlet. Check all connections, then try another input cable.
Audible buzz or hum	Input cable not securely connected or defective. Single HI LEVEL input connected to the RIGHT channel only. Ground loop through antenna or cable TV system input.	Check all connections, then try another input cable. Connect to the LEFT input channel. Test by disconnecting antenna and/or cable system input leads. If hum goes away, install isolation balun(s) at that point.
Weak bass	Subwoofer too far from the wall. VARIABLE INPUT LEVEL set too low.	Move the subwoofer closer to a wall or corner. Turn control up somewhat.
Weak bass: vague stereo image	Input source connected to HI LEVEL inputs is wired out of phase.	Check speaker wire connections and reconnect in proper phase.

For Future Reference

Record your speaker serial number and date of purchase here:

Model Number

Serial Number

Date of Purchase

The serial number is found on the back of the speaker near the connecting terminals.



CAUTION: To reduce the risk of electric shock, do not remove the cover (or back). No user serviceable parts inside. Refer to qualified personnel.

WARNING: To reduce the risk of fire or electric shock, do not expose this appliance to rain or moisture.



The lightning flash with arrowhead, within an equilateral triangle, is intended to alert the user to the presence of uninsulated "dangerous voltage" within the product's enclosure that may be of sufficient magnitude to constitute a risk of electrical shock to persons.



The exclamation point within an equilateral triangle is intended to alert the user to the presence of important operating maintenance (servicing) instructions in the literature accompanying the appliance.

Free Manuals Download Website

<http://myh66.com>

<http://usermanuals.us>

<http://www.somanuals.com>

<http://www.4manuals.cc>

<http://www.manual-lib.com>

<http://www.404manual.com>

<http://www.luxmanual.com>

<http://aubethermostatmanual.com>

Golf course search by state

<http://golfingnear.com>

Email search by domain

<http://emailbydomain.com>

Auto manuals search

<http://auto.somanuals.com>

TV manuals search

<http://tv.somanuals.com>