



ATLONA

1 x 6 SDI/HD-SDI DISTRIBUTION AMPLIFIER

USER'S MANUAL

MODEL: AT-SDI-16



REV.0911

TABLE OF CONTENTS

1. Introduction	1
2. Features	1
3. Package Contents	1
4. Specifications	2
5. Panel Description	3
6. Installation	4
7. Safety Information	5
8. Warranty	6
9. Atlona Product Registration	7

INTRODUCTION

Atlona Technologies AT-SDI-16 is a high-performance distribution amplifier for SDI (SMPTE 259M and HD-SDI (SMPTE 292M) signals. It takes one input and distributes the signal to four identical outputs. The Atlona SDI/HD-SDI distribution amplifier can work with High Resolutions up to 1080p and full bandwidth up to 1.48Gbps.

FEATURES

- ★ Supports high video bandwidth up to 1.48Gbps
- ★ Splitter supports both SDI (SMPTE 259M) and HD-SDI (SMPTE 292M) standard
- ★ All SDI / HD-SDI outputs are buffered to send signal further
- ★ HD cable equalization
- ★ Passes all ancillary data
- ★ Provides automatic input cable equalization up to 300m (1000ft)
- ★ Interlocked power supply for better fixedness

PACKAGE CONTENTS

- ★ 1x AT-SDI-16 unit
- ★ 1x 5V DC power supply unit
- ★ 1x User's manual

SPECIFICATIONS

Model name		AT-SDI-16
Technical		
SDI standards	SDI & HD-SDI	
Auto SDI / HD-SDI detection	Yes	
Supported protocols	SMPTE 259M, SMPTE 292M HDTV (1.485Gbps and 1.485/1.001Gbps)	
Video bandwidth	1.485Gbps & 1.485/1.001Gbps	
Data rates	270 / 1483 / 1485 Mbps	
Video support	[HD] 720p50/59.94/60; 1035i50/59.94/60 1080i50/59.94/60, 1080p24/30 [SD] NTSC@59.94Hz, PAL@50Hz	
SDI signal type	SMPTE-292M, SMPTE-259M	
Output impedance	75Ω	
Reclocking function	No	
Cable equalization	[HD-SDI] up to 150m (500ft) / [SD-SDI] up to 300m (1000ft)	
Audio support	Yes	
RP-198 pathological patterns	Immune	
Input	1x BNC [SDI]	
Output	6x BNC [SDI]	
BNC connector	75Ω inter-locked socket	
Eye pattern characteristics	Amplitude: Within 800mV ±3% (<10%) Long time jitter: 0.195μ (<1.0μ) Rise overshoot: Less than 2% (<10%) Timing jitter: 0.195μ (<1.0μ) Fall overshoot: Less than 2% (<10%) Alignment jitter: 0.127μ (<0.2μ)	
Mechanical		
Housing	Metal enclosure	
Dimensions [L x W x H]	Model	145 x 80 x 25mm [5.7"x3.2"x1"]
	Package	270 x 175 x 80mm [10.6"x6.9"x3.2"]
Weight	Model	330g [12oz]
	Package	805g [1.8 lbs]
Fixedness	Inter-locked power supply	
Power supply	5V 4A DC	
Power consumption	10 Watts [max]	
Operation temperature	0~40°C [32~104°F]	
Storage temperature	-20~60°C [-4~140°F]	
Relative humidity	20~90% RH [no condensation]	

The measurement results are from Tektronix WFM-7120 with SDI through 1m (3.3ft) long Belden 1694A.

PANEL DESCRIPTION

AT-SDI-16 [Front Panel]

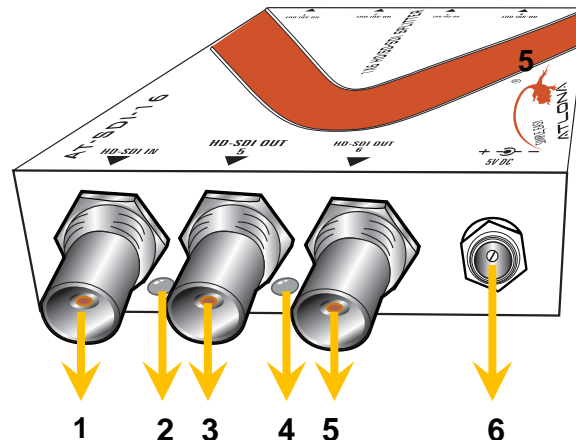

1. SDI / HD-SDI input
2. Reserved, not in use for this model.
3. HD/SD-SDI output 5
4. Power on/off indicator
5. HD/SD-SDI output 6
6. +5V DC power jack

AT-SDI-16 [Rear Panel]

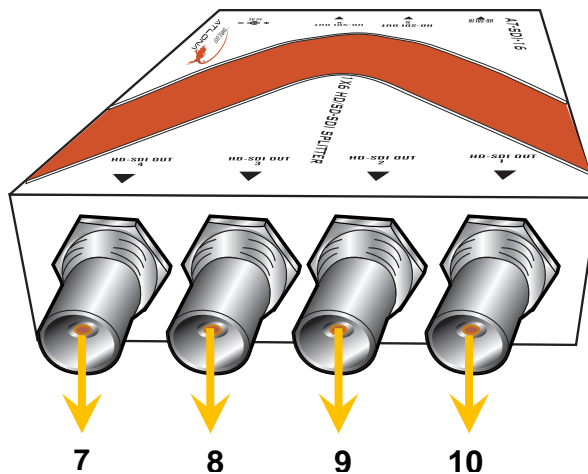

7. HD/SD-SDI output 1
8. HD/SD-SDI output 2
9. HD/SD-SDI output 3
10. HD/SD-SDI output 4

AT-SDI-16 [Bottom Panel]

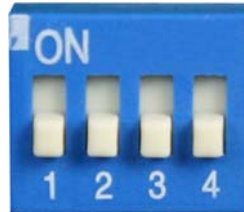

The 4-pin DIP switch is reserved for AT-SDI-14RC and AT-SDI-16RC that have re-clocking functionality. It's not in use for AT-SDI-16.

INSTALLATION

1. Connect a camera or other devices equipped with SDI / HD-SDI outputs to AT-SDI-16 HD/SD-SDI input.
2. Connect devices equipped with SDI / HD-SDI inputs (e.g. monitors or video processors) to AT-SDI-16 HD/SD-SDI outputs.
3. Connect to the 5V/4A power supply unit.

Diagram:

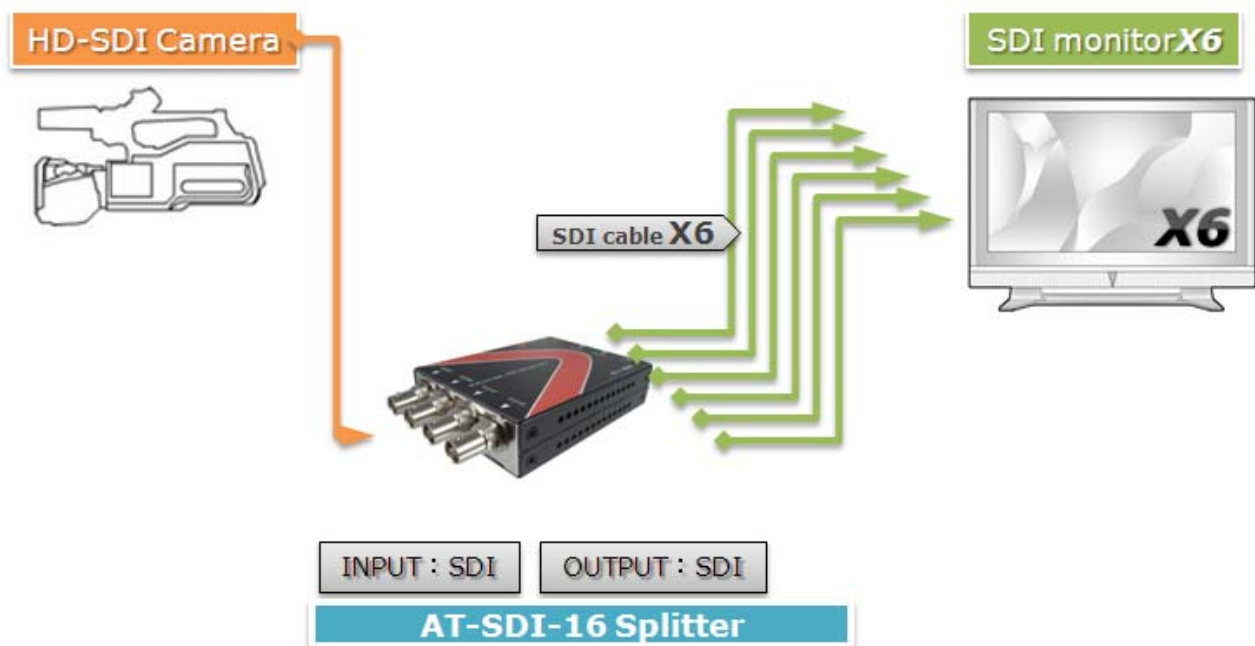

Safeguards

To reduce the risk of electric shock, do not expose this product to rain or moisture.

If the wall plug does not fit into your local power socket, hire an electrician to replace your obsolete socket.

Do not modify the wall plug. Doing so will void the warranty and safety features.

This equipment should be installed near the socket outlet and the device should be easily accessible in case it requires disconnection.

Precautions

FCC Regulations state that any unauthorized changes or modifications to this equipment not expressly approved by the manufacturer could void the user's authority to operate this equipment.

Operate this product using only the included external power supply. Use of other power supplies could impair performance, damage the product or cause fires.

In the event of an electrostatic discharge, this device may automatically turn off. If this occurs, unplug the device, and plug it back in.

Protect and route power cords so they will not be stepped on or pinched by anything placed on or against them. Be especially careful of plug-ins, or cord exit points from this product.

Avoid excessive humidity, sudden temperature changes or temperature extremes.

Keep this product away from wet locations such as bathtubs, sinks, laundries, wet basements and swimming pools.

Use only accessories recommended by ATLONA to avoid fire, shock or other hazards.

Unplug the product before cleaning. Use a damp cloth for cleaning. Do not use cleaning fluid or aerosols, which could enter the unit and cause damage, fire or electrical shock. Some substances may also mar the finish of the product.

Never open or remove unit panels or make any adjustments not described in this manual. Attempting to do so could expose you to dangerous electrical shock or other hazards. It may also cause damage to your AT-SDI-16. Opening the product will void the warranty.

Do not attempt to service the unit. Instead disconnect it and contact your Authorized ATLONA reseller or contact ATLONA directly.

WARRANTY

1. LIMITED WARRANTY

Atlona Technologies warrants that (a) its products (the "Product") will perform substantially in accordance with the accompanying written materials for a period of 3 years from the date of receipt and (b) that the Product will be free from defects in materials and workmanship under normal use and service for a period of 3 years. In the event applicable law imposes any implied warranties, the implied warranty period is limited to 3 years from the date of receipt. Some jurisdictions do not allow such limitations on duration of an implied warranty, so the above limitation may not apply to Customer.

2. CUSTOMER REMEDIES

Atlona Technologies and its suppliers' entire liability and Customer's exclusive remedy shall be, at Atlona Technologies' option, either return of the price paid for the Product, or repair or replacement of the Product that does not meet this Limited Warranty and which is returned to Atlona Technologies with a copy of Customer's receipt. This Limited Warranty is void if failure of the Product has resulted from accident, abuse, or misapplication. Any replacement Product will be warranted for the remainder of the original warranty period or 3 year, whichever is longer.

3. NO OTHER WARRANTIES

TO THE MAXIMUM EXTENT PERMITTED BY APPLICABLE LAW, ATLONA TECHNOLOGIES AND ITS SUPPLIERS DISCLAIM ALL OTHER WARRANTIES, EITHER EXPRESS OR IMPLIED, INCLUDING, BUT NOT LIMITED TO IMPLIED WARRANTIES OF MERCHANTABILITY AND FITNESS FOR A PARTICULAR PURPOSE, WITH REGARD TO THE PRODUCT AND ANY RELATED WRITTEN MATERIALS. THIS LIMITED WARRANTY GIVES CUSTOMER SPECIFIC LEGAL RIGHTS. CUSTOMER MAY HAVE OTHER RIGHTS DEPENDING ON THE JURISDICTION.

4. NO LIABILITY FOR DAMAGES

TO THE MAXIMUM EXTENT PERMITTED BY APPLICABLE LAW, IN NO EVENT SHALL ATLONA TECHNOLOGIES OR ITS SUPPLIERS BE LIABLE FOR ANY DAMAGES WHATSOEVER (INCLUDING WITHOUT LIMITATION, SPECIAL, INCIDENTAL, CONSEQUENTIAL, OR INDIRECT DAMAGES FOR PERSONAL INJURY, LOSS OF BUSINESS PROFITS, BUSINESS INTERRUPTION, LOSS OF BUSINESS INFORMATION, OR ANY OTHER PECUNIARY LOSS) ARISING OUT OF THE USE OF OR INABILITY TO USE THIS PRODUCT, EVEN IF ATLONA TECHNOLOGIES HAS BEEN ADVISED OF THE POSSIBILITY OF SUCH DAMAGES. IN ANY CASE, ATLONA TECHNOLOGIES' AND ITS SUPPLIERS' ENTIRE LIABILITY UNDER ANY PROVISION OF THIS AGREEMENT SHALL BE LIMITED TO THE AMOUNT ACTUALLY PAID BY YOU FOR THE PRODUCT. BECAUSE SOME JURISDICTIONS DO NOT ALLOW THE EXCLUSION OR LIMITATION OF LIABILITY FOR CONSEQUENTIAL OR INCIDENTAL DAMAGES, THE ABOVE LIMITATION MAY NOT APPLY TO YOU.



ATLONA
2151 O'toole Ave, Suite D
San Jose, CA 95131
Toll Free: 1-877-536-3976
International: 408-954-8782
FAX: 408-954-8792
Website: www.atlona.com
E-MAIL: info@atlona.com

ATLONA PRODUCT REGISTRATION

Thank you for purchasing this Atlona product — we hope you'll enjoy it.



We also hope that you'll take a few moments to register your new purchase. Registration creates an ownership record if your product is lost or stolen and helps ensure you'll receive notification of performance issues and firm-ware updates.

At Atlona, we respect and protect your privacy and assure you that your registration information is completely secure. Of course, Atlona product registration is totally voluntary and failure to register will not diminish your limited warranty rights.

To register go to www.atlona.com/registration

Free Manuals Download Website

<http://myh66.com>

<http://usermanuals.us>

<http://www.somanuals.com>

<http://www.4manuals.cc>

<http://www.manual-lib.com>

<http://www.404manual.com>

<http://www.luxmanual.com>

<http://aubethermostatmanual.com>

Golf course search by state

<http://golfingnear.com>

Email search by domain

<http://emailbydomain.com>

Auto manuals search

<http://auto.somanuals.com>

TV manuals search

<http://tv.somanuals.com>