

**Digital
Fusion™ Mobile Audio**

DQTtm
Stereo One-Third Octave
Digital Equalizer

Owner's Enjoyment Manual

AudioControl®

22410 70th Avenue West • Mountlake Terrace, WA 98043 USA

Phone 425-775-8461 • Fax 425-778-3166

www.audiocontrol.com

AudioControl

This page was intentionally left blank

Owner's Enjoyment Manual

Table of Contents

Introduction	1
Features and Highlights	1
Quick Installation Information	3
A Guided Tour of the DQT	4
Installing the DQT	6
Placement and Mounting	6
Power Wiring	6
Audio Wiring	7
Level Matching	8
DQT Menu Screens	9
Equalization Adjustment	12
Graphic versus Parametric Equalization	14
Troubleshooting	15
Warranty	16
Specifications	19

AudioControl



Owner's Enjoyment Manual

Introduction

Welcome to the world of Digital Fusion. The fusion of AudioControl's lengthy experience in performance signal processing combined with state-of-the-art Digital Signal Processing (DSP) technology. Congratulations also on your purchase of the DQT, the world's first thirty-band, one-third octave stereo and parametric, digital equalizer, utilizing AudioControl's Digital Fusion technology. Whether you are a die-hard sound-off competitor or you just enjoy good music, you will definitely enjoy how great the DQT will make your performance autosound system sound.

Now before you start salivating too much just thinking about the benefits of the DQT, take a few minutes to sit back, have a latte', decaffeinated if necessary, and read through this manual. It contains lots of useful facts and information - - and besides, we spent a lot of time writing it!

KEY FEATURES OF THE DQT

Here are some of the cool features that are enclosed in this magical box:

- 30 bands of constant-Q equalization
- Dual, fully-adjustable parametric equalizers
- Eight non-volatile memories
- 24 bit digital signal processing
- Digital Fusion technology
- Balanced differential inputs

FEATURES AND HIGHLIGHTS

24 bit Digital Signal Processing:

AudioControl's Digital Fusion signal processors use a special 24 bit DSP that was specially designed for equalization and other dynamics processing. In addition, matching 24 bit A/D - D/A converters are incorporated for maximum sound quality.

Constant-Q equalization controls: Car interiors vary widely in size and acoustic make-up. In addition doors, kick-panels, and rear decks don't make the best location for speaker placement causing your high performance speaker system to sound somewhat lackluster. The DQT offers thirty precise equalization controls, spread equally across the audio spectrum, at one-third

AudioControl

octave increments for maximum control. In addition each equalization filter utilizes precise constant-Q topology, traditionally utilized only in the highest performing professional audio products.

Parametric equalization controls: In addition to the thirty, one-third octave spaced controls, the DQT also offers two, fully-adjustable parametric equalization controls for each channel. With the DQT's parametric controls, a user can select a center frequency, dial in the ideal bandwidth and apply the appropriate amount of boost or cut. The precise filtering of the DQT allows you to select bandwidths as narrow as 1/12 octave!

Non-volatile memories: The DQT has the ability to allow the user to set and store eight different equalization settings in individual memory locations.

Pre-Amp Line Driver: The DQT offers a high quality line driver that takes the low output voltage of a source unit and increases it up to 18dB. This allows you to drive your amplifiers to their maximum output without clipping. No hiss, clicks, or pops plus maximum sound quality.

Bulletproof Warranty: The most important feature of all. Every AudioControl product is selflessly designed and manufactured by the occupants of our Pacific Northwest rainforest factory. We take every effort to ensure that you will have many years of enjoyment out of your DQT. To ensure the performance of this new Digital Fusion product, we highly recommend that you allow your authorized AudioControl dealer to perform the installation. Not only do they have all the right knowledge and tools, but in the unlikely chance your DQT should stop working, we will back it with a limited five years parts and labor warranty. Should you choose to install it yourself we will still give you one-year parts and labor warranty. To activate your warranty, you need to **FILL OUT AND SEND IN YOUR WARRANTY CARD!**

We also recommend that you save your invoice or sales slip as proof of installation and ownership. Not only is it necessary for warranty purposes, but should your DQT “disappear” one day while your car is parked at your local latte’ stand, you will find insurance companies very unforgiving without proof of purchase.



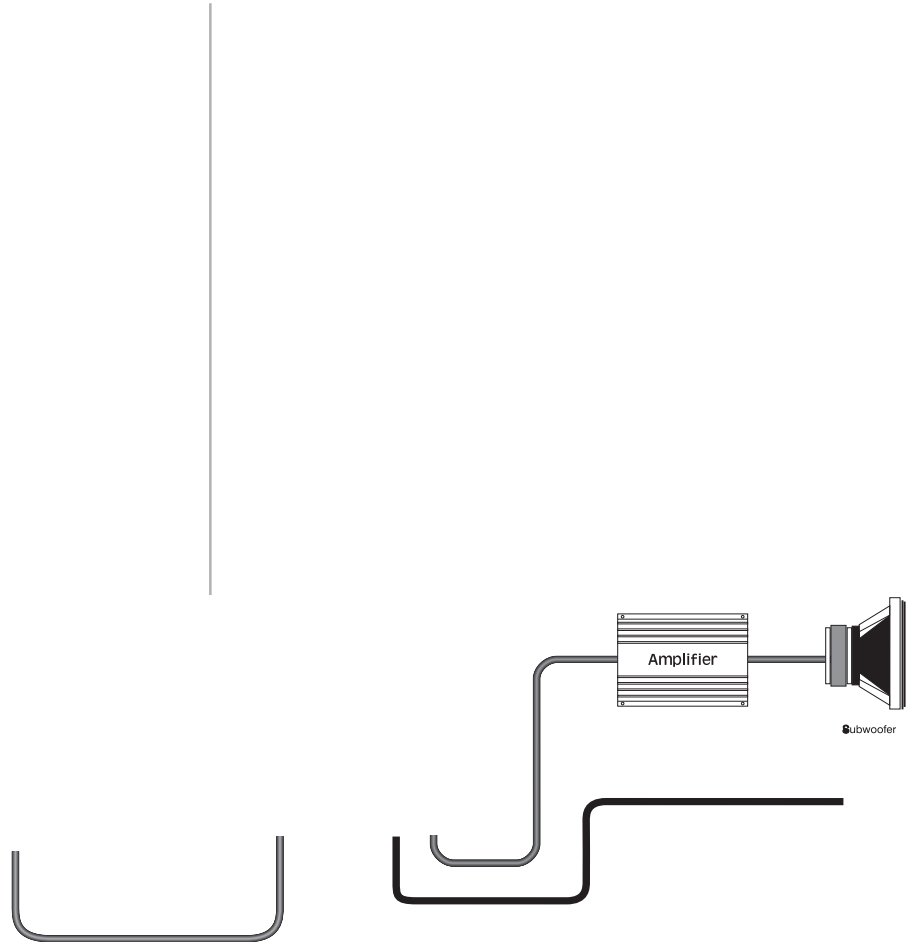

Owner's Enjoyment Manual

AudioControl

A GUIDED TOUR OF THE DQT

1) Inputs: The DQT has two RCA inputs that need to get their audio signals from your source unit. If your source unit has multiple outputs (like a front, rear, and/or subwoofer) you only need to connect the front or rear outputs to your DQT.

2) Input Level: This knob allows you to maximize the signal level from your source unit that goes into your DQT to achieve maximum signal to noise. Keep in mind, that despite what the literature says, most aftermarket source units produce a relatively low voltage signal when it comes to playing music at normal levels.

3) Input Maximized Indicator: This nifty LED light indicates that you are supplying the DQT its maximum amount of signal voltage. If the LED indicator never comes on, don't assume that you it is not working (since LED's rarely break) but you might consider adding a line driver to your system.

4) Output Level Control: Although your DQT has the ability to increase your signal voltage 18 dB, your amplifiers may not necessarily accept that much signal. These controls allow you to regulate the proper amount of pre-amp signal from the DQT to the amplifiers.

5) Equalization Overload Indicator: This convenient LED indicates when the DSP (digital signal processor) of your DQT is clipping or distorting. The usual cause of this is having the "Input Level" turned up too high or you have boosted too many frequencies on your equalizer.

6) Select: This allows you to scroll through the various equalization or memory modes of your DQT.

7) Navigation Arrows: These multi-function buttons let you navigate within each of the various modes and utilize the features of your DQT.

8) Output Voltage Indicators: These brightly colored LED's indicate the level of signal voltage at the outputs of your DQT. You will be happy to know that they dance up and down with your music.

9) Outputs: These RCA connectors should be connected to the next component after the DQT, such as a crossover or amplifier. Do not connect any speakers directly to your DQT or connect your DQT to any home appliances, like your toaster.

10) Power Connections: This nifty connector is a godsend to anyone who has tried to wire up their gear with their body crammed in the trunk. You can wire up the power, ground, and remote turn-on from the convenience of outside your car and then casually plug it into your DQT.

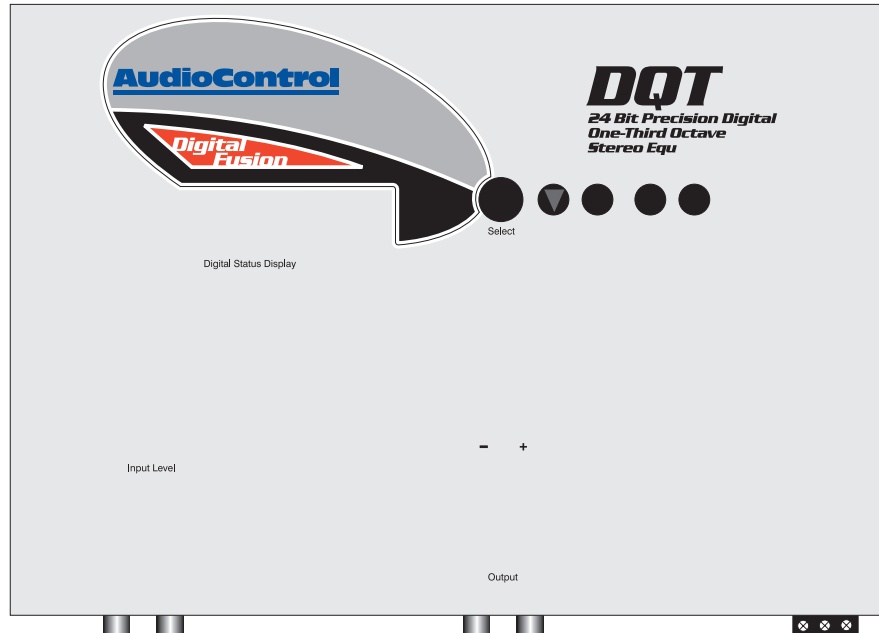

- 1
- 2
- 3
- 4
- 5
- 6
- 7
- 8
- 9
- 10

Figure 2: Top view of DQT

AudioControl

INSTALLING THE DQT

Up to this point everything you have read has served to educate you on the operations of your DQT. We are sure that you are now chomping at the bit to install your DQT so we recommend you read the following sections very carefully.

A. Placement and mounting of the DQT

Placement: The DQT needs to be installed in the signal path after your source unit but definitely before your amplifiers and/or any other signal processors or active crossovers. The chassis is usually mounted in the rear of the vehicle, as close to the amplifiers as possible.

Mounting: Once you have selected a permanent mounting location, position the unit and mark the appropriate mounting holes with a felt-tip pin or scratch awl. Before doing anything else, make sure you are not about to drill a hole in a gas tank or piercing any existing wiring. Nothing ruins your day more than an expensive repair bill. Drill a few small pilot holes and secure the chassis of the DQT with self-tapping screws.

Figure 3: Side view of DQT with power connector and RCAs



B. DQT Power Wiring



WARNING: Failure to disconnect the negative terminal of your battery prior to the installation of your DQT can result in a warm tingly feeling.

Remote Turn-On: Connect a 22 to 18 gauge wire from the head-unit's remote turn-on to the "Remote" connector on the DQT.

Positive(+12V) Connection: Insert a 12-18 gauge wire into the connector labeled "Power" on the nifty connector of your DQT. Connect it to a good constant source of 12 volts (we suggest the battery), fused at 1 amp.

Ground Connection: Use the same gauge wire as you did for the positive connector and run it from the "Ground" connector on the DQT to the negative terminal of the battery, a ground bus, or a verified ground location. The factory head unit ground is not a good ground!

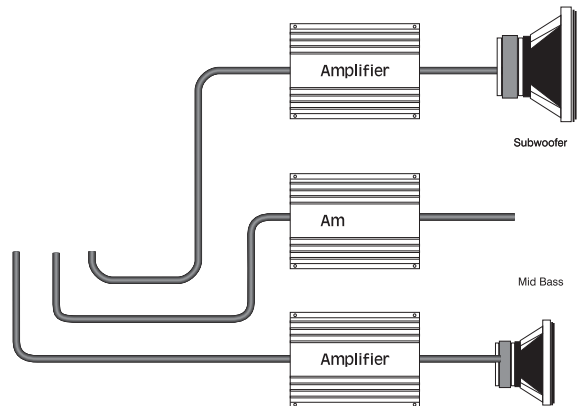

Owner's Enjoyment Manual

AudioControl

planning out your system and even sketching it out on paper. The following diagrams are just a few of the system options:

D. Level Matching

If you have ever listened to a friend's "killer" car audio system and heard lots of hiss, clicks or pops, then you have experienced an improperly level matched system. When a performance autosound system is properly level matched, you should get the maximum output from your source unit processors and amplifiers without any clipping or that annoying hiss! The following steps will help guide you through the process, although at the end of the day, your ears will be your guides!

- 1) Set your source units fader and balance controls to their center positions.
- 2) Disconnect the output RCA connections between your DQT and the amplifier(s)... or next processor in line.
- 3) Start playing some relatively dynamic music and set the volume on your source unit to about $\frac{3}{4}$ of maximum. You should not be hearing anything at this point. If you are hearing music, go back to step #2; if you are hearing voices go see a doctor!

- 4) Starting with the DQT "Input Level" control, increase or decrease the control knob until the "Input Maximized" LED begins to flicker steadily with the music.
- 5) Now adjust the output level control until the "2 volt" or "5 volt" light starts to flicker. You will want the output voltage to match up your amplifiers input gain levels. If you don't know how much this is, ASK the amplifier manufacturer or read the owners manual of the amplifier.
- 6) Very Important - Set the input gains on the amplifier(s) at minimum!
- 7) Double check that you performed Step #6
- 8) Decrease the volume control on your source unit and re-connect the RCA's between the DQT and the amplifier(s).
- 9) Now increase the volume on your source unit to your normal listening level. For some of you, this may be louder than others!
- 10) At this point you may find yourself going back and adjusting the "Output Level" controls on your DQT to accommodate for the speaker placement and efficiency.



Note After making your equalization settings you may need to readjust your output levels.

DQT MENU SCREENS

One of the major benefits of using Digital Fusion technology is the ability to use less knobs and buttons and get more control. The DQT has two mono 30 band graphic equalizers plus two stereo parametric equalizers. This is a stack of equipment that would normally fill your trunk. Digital Fusion technology allows the DQT to offer a plethora of features in one compact chassis. In addition there are only a few buttons to learn so navigating through the DQT's functions is quite simple.

When you first apply power to your DQT, it will go through a "wake up" screen, including some subliminal advertising for AudioControl. It will then display a friendly blue screen. Fear not, the blue screen on the DQT is actually a good thing. Press the Select button to select through the menus. Once your DQT has settled on one of these menu screens, you will want to spend a few minutes familiarizing yourself with the various modes.

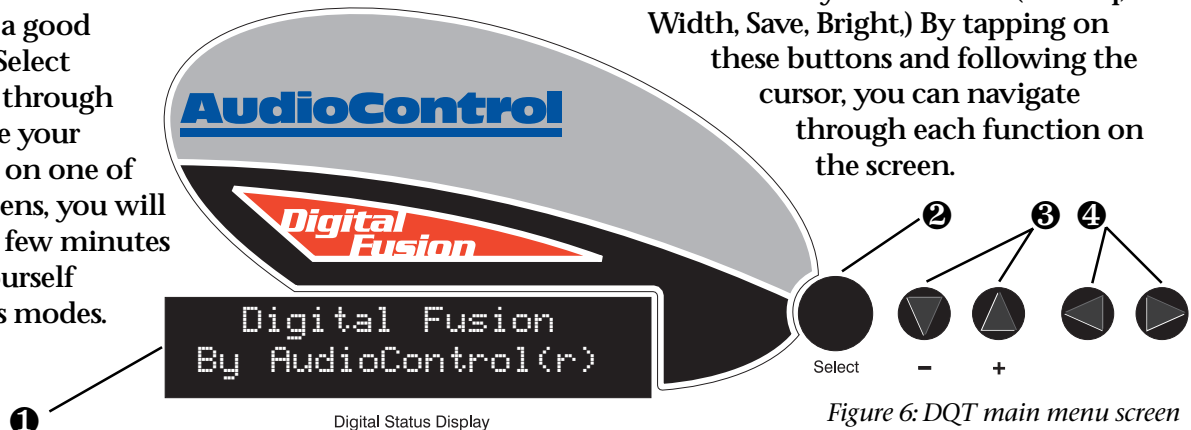

Figure 6: DQT main menu screen

- 1) **Digital Status Display:** This sexy blue display reflects which mode your DQT is in.
- 2) **Select:** Every time you touch this button, your display will change reflecting the fact that you are now accessing a one of the various modes in the DQT. Your choices are GraphicEQ, ParaEQ 1, ParaEQ 2, Memories, or Display. After a brief period of no key presses, the display will return the Splash Screen.
- 3) **“+” and “-” Navigation Buttons:** Depending upon where your cursor is flashing, these buttons will allow you to change a frequency, apply boost and/or vary the bandwidth of your equalization filters.
- 4) **Left and Right Navigation Buttons:** Within each mode there are generally 4 or 5 different functions you can select (i.e. Freq, Width, Save, Bright,) By tapping on these buttons and following the cursor, you can navigate through each function on the screen.

AudioControl

MODE: GraphicEQ



Graphic EQ Freq = 1kHz
L= +6dB >< R =+4dB

Figure 7: Graphic EQ screen

Your DQT has 30 built-in graphic equalization filters with fixed, constant-Q, center frequencies. They just happen to match those on the AudioControl SA-3055 real time analyzer. In the GraphicEQ mode, you can select any of the 30 frequencies, one at a time and apply boost or cut. In addition you can select whether you want the equalization controls to affect the left and right channels individually or control both channels at the same time.

Freq (uency): This corner of the screen shows which frequency you are boosting and cutting. If you wish to select another frequency, just tap the left or right arrow buttons until the cursor is flashing on the number next to “Freq=.” Then use the + or - controls allows to select the frequency you wish to apply boost or cut.

Stereo Equalization: After you have selected a frequency, use the left and right navigation controls to move the cursor until it stops on the

symbol “><“ in the middle of the lower part of the screen. By tapping the “+ or -” buttons you can apply an equal boost or cut to both channels.

Separate left and right equalization: If you wish to apply boost or cut to the left or right channels individually, tap the left or right arrows and the cursor will move to the number after “L= or R=”. You can now apply boost or cut, using the “+ or -” controls.

Once you have made your equalization setting, you will want to tap the Select button, go to the Memories screen, and save your equalization settings in one of the memory locations.

MODE: ParaEQ 1and ParaEQ2



Para EQ1 Freq=3.15k
Width=1/6 LVL=+12dB

Figure 8: Para EQ1 screen



Para EQ2 Freq=3.15k
Width=4 oct LVL=0dB

Figure 9: Para EQ2 screen

Besides offering a 30 band graphic equalizer, your DQT also has two, fully programmable parametric stereo equalizers. These allow you to

select a frequency, apply the proper amount of boost or cut, and change the bandwidth or “Q” of the filter.

Para EQ1 mode allows you set the controls for one of the parametric equalizers.

Para EQ2 lets you change the settings for the second parametric EQ band.

Freq (uency): This corner of the screen shows which frequency you are boosting and cutting. If you wish to select another frequency, just tap the left or right arrow buttons until the cursor is flashing on the number next to “Freq. Then use the + or - controls allows to select the frequency you wish to apply boost or cut.

Lvl: When the cursor highlights on this screen, you can now apply boost or cut to both channels, using the “+ and -” controls. You will note that you cannot use the parametric equalizers on the left and right channels individually.

Width: This control lets you select how wide of an area the DQT’s parametric equalizer affects. You can choose a real narrow bandwidth, like 1/12th of an octave or go as wide as three full octaves.

MODE: Memories



Figure 10: EQ Recall Memories screen



Figure 11: EQ Save Memories screen

This screen allows you to save or recall settings using one of the eight memory locations. Using the Left and Right navigation arrows will cause the cursor to highlight one of the following functions:

Recall: Use the left or right navigation arrows to move the cursor next to the word Recall. Push the “+” or “-” button to change the memory to which you are listening. All the stored settings are automatically recalled as you change the memory number.

Save: Once you have made your graphic and parametric equalization settings, you will want to store them in one of the eight memory locations. To save a memory, you need to use the left/right navigation arrows to move the cursor until it is

AudioControl

flashing next to Save. Push the “+” or “-” buttons to select the memory destination to where you are saving. Then use the left/right navigation buttons to move N(-) Y(+) display area. Tap the “(+)” button to complete the saving process or (-) to quit the memory saving process.

MODE: Display

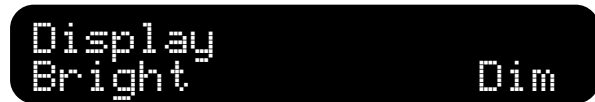

Figure 12: Display screen

In this mode, you have the ability to select between two levels of brightness for the display on your DQT. Using the left and right navigation buttons, toggle back and forth between “Bright” and “Dim” and stop on the level of lighting you are most comfortable with you. Tap the “Select” button and your last display brightness setting will be retained as you move on to the next mode.

ADJUSTING THE EQUALIZER

When it comes to music, everyone has his or her own particular taste. Some people want pounding bass and crisp, blood curdling highs. Others may prefer a “flat” response, or at least think it is flat. At the end of the day, most people just want their system to sound balanced, “just like it did in the store” or their buddy’s car. The following equalization guidelines should help you achieve your own personal audio nirvana.

- 1) For optimum performance, get your hands on a test compact disc that contains pink noise and a good quality RTA (real time analyzer); we happen to know someone who makes a really good one. If you cannot locate an RTA, you probably want to have your authorized AudioControl dealer perform the equalization adjustments as they will have one. You can certainly “try” adjusting your DQT using your ears, however an RTA will give you the best results.
- 2) Begin playing pink noise through your system and place the microphone for your analyzer on a microphone stand in the drivers seat. The microphone should be sitting where your head

usually goes. Take a careful look at the “curve” on your analyzer and how one frequency combines with the next. There is no one curve that will satisfy every person, as we all have different tastes. How else can you explain Liberace or rice cakes? The key is to use your DQT to help balance your system from one frequency to the next and give your speakers the sparkle, sizzle, detail or punch that the acoustics of the car have compromised.

- 3) You will want to start equalizing by removing any large bumps, peaks, or areas with too much energy at a particular frequency. Next, boost the ranges that do not have enough energy. We strongly recommend that you cut or decrease energy before you boost.
- 4) Although the plethora of controls on your DQT can be intimidating, fear not as they were

designed to give enough control to maximize your systems performance but not enough to get you in trouble. Here is an explanation of the key areas you should focus on:

Sub-bass: 100 Hz and below - A car without bass is like a day without sunshine... unless you live where we do because most of the days in the Pacific Northwest do not have sunshine. This area is one of the more difficult to properly reproduce. Most people refer their bass frequencies to be 6 to 9 dB louder than the rest of their system, although there are some crazy folks that prefer their bass substantially louder. The key in this area is to have enough speakers and power to produce the amount of bass you desire but don't use the controls on the DQT to try and force your speakers to produce sounds they can't. Too much bass boost creates a condition called “speakerus explodus”, which is not pretty to hear or watch.

Midbass: 100 Hz to 300Hz - The phrase, “too much of a good thing” can certainly apply to the midbass frequencies. This is the transition

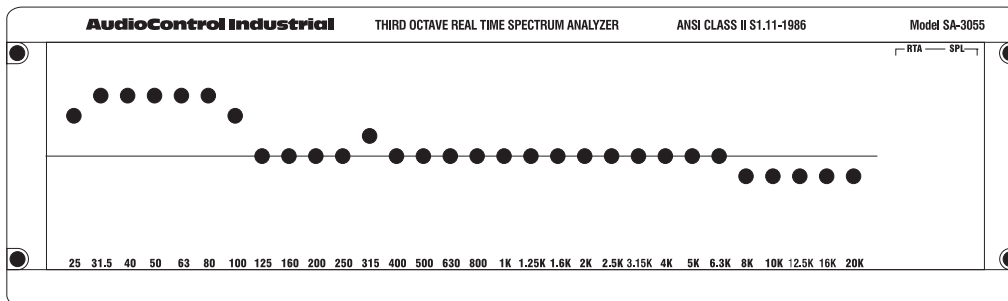

Figure 13: sample curve

AudioControl

area of the audio spectrum that is an octave above your sub-bass frequencies and several octaves below your midrange. Most autosound systems have too much midbass due to the fact that speakers mounted in the doors or kick panels cause resonance's or peaks in the response curve. These peaks in the midbass can actually mask or block sounds in the all-important midrange area causing your system to sound dull or lifeless. This is one of the areas where the parametric controls on your DQT will work well.

Midrange: 300Hz to 3Khz - Musical instruments, vocals, mid-range percussion and many things we associate with imaging and staging happen in this area of the bandwidth. For that reason you will want to keep this area as smooth and balanced as possible. Too much boosting can make you feel like your listening to your system in a tile bathroom. Not enough energy midrange sounds empty and dry.

Treble: 3KHz and Up - If midrange is the cake, then these high or upper frequencies are considered the frosting. Many autosound systems start a gradual decline in this area due to low speaker placement (which is why speaker placement is very important). Too much boosting can really make a speaker sound unnatural.

GRAPHIC VERSUS PARAMETRIC EQUALIZATION

Your DQT is a very unique equalizer as it contains both a 30 band Graphic and a 2 band parametric equalizer. Depending upon the situation in your system you will probably find yourself using both graphic and parametric controls. Both perform special functions that you will want to take full advantage of.

The graphic equalizer in your DQT has 30 frequency controls with fixed center frequencies and fixed bandwidths that use a precise constant-Q topology. What this means is that if you are applying boost or cut at 500 Hz, you will have very little affect on the frequencies below and above 500 Hz.

On the other hand, the parametric equalizer gives you the ability to select a center frequency, increase or decrease the bandwidth (how wide or narrow of an area you wish to equalize) and then apply boost or cut. A parametric works best in areas where you would generally be combing several graphic bands to affect a certain area of the audio spectrum. For example, if your system has a too much midbass, you would normally have to use several of the Graphic Equalization controls at

100 Hz, 125 Hz, 160 Hz, 200 Hz, and 250 Hz to control the area. Or you can use *one* parametric control centered at 160 Hz and set the bandwidth at 1 octave and you can perform a global adjustment of the entire midbass region.

The other excellent use for a parametric band is very narrow cut of a problem area. The $\frac{1}{12}$ and $\frac{1}{6}$ octave band width allows this narrow fine tuning.

TROUBLESHOOTING

No Power: If the Power LED on your DQT does not turn on, check to make sure that the power wire and remote turn on wires are connected or a fuse is not blown.

System Sounds Unbalanced: Check your graphic equalization settings to make sure that one channel is not dramatically different than another.

Sounds Distorted: Should your system sound distorted or your speakers are moving way too much, you should make sure you have your levels matched properly and that your amplifier gains are set at minimum. Make sure the “Maximized” or “Overload” LEDs are not on steady. If this checks out okay, you will want to look at your EQ controls to insure that your boost levels are not too high.

Still Sounds Distorted: Look at the frequencies that you have selected for *Para EQ 1* and *Para EQ 2* and see how much boost or cut you have applied. Then look at those same frequencies on your *Graphic EQ*. If you have boost applied to the same frequencies on both types of equalizers, there is a strong chance you are overdriving your speakers and amplifiers at that frequency.

Output Voltage LED's Don't Light Up: If your system is playing music but none of the output LED's are on, there is a good chance that the output voltage of your source unit is not that strong. Now before you call us and say, “The guy at the store said my radio has high-voltage output”, you might want to face the fact that there is “Engineering Voltage” and there is “Marketing Voltage”. Most source units are also tested at maximum output, not the level that most of us listen to. Without picking on any particular source unit, remember that you do get what you pay for.

AudioControl

UNDER THE COVER

Beside all of the clever buttons on the outside of your DQT, there are a few factory preset functions, located under the cover, that assist in maximizing the performance of your DQT. To access these jumpers you will need to remove the 4 each top screws and carefully lift the chassis top. You will note that there is a ribbon cable that connects the display, mounted on the chassis top, to the main circuit board. Once under the cover, you will access to the following jumpers:

1. Input Grounding: For most systems you can leave this jumper set in the BALANCED position. In some systems, the amplifier may look for a ground through the RCA connection to the source unit and create a ground loop, which in turn can cause a whine (not the type that comes in a bottle) in your system. In that event, you

IF YOU LIKE DQT, YOU'LL LOVE...

If you need a crossover for your system that keeps up with your DQT, another member of the Digital Fusion family is the DXS™, a 2 channel, 3-way crossover with breath takingly steep 24dB per octave slopes. If performance is important to you, then you will appreciate the DXS.



The FOUR.1i is the perfect in-dash equalizer for those of you who like the sound and detail of the DQT but want to have some control of your system from the dash of your car. Of course you should not be driving while tweaking your FOUR.1i, but enjoy it nevertheless.

And now a word from the legal department. . .

THE WARRANTY

People are scared of warranties. Lots of fine print. Months of waiting around. Well, fear no more, this warranty is designed to make you rave about us to your friends. It's a warranty that looks

out for you and helps you resist the temptation to have your friend, "...who's good with electronics", try to repair your AudioControl product. So go ahead, read this warranty, and then take a few days to enjoy DQT before sending in the warranty card and comments.

"Conditional" doesn't mean anything ominous. The Federal Trade Commission tells all manufacturers to use the term to indicate that certain conditions have to be met before they'll honor the warranty. If you meet all of these conditions, we will warrant all materials and workmanship on your DQT for one year from the date you bought it (five years if it is installed by an authorized United States AudioControl dealer). We will fix or replace it, at our option, during that time.

Here are the conditional conditions:

1. You have to fill out the warranty card and send it to us within 15 days after purchasing DQT.
2. You must keep your sales receipt for proof of purchase showing when and from whom the unit was bought. We're not the only ones who require this, so it's a good habit to get into with any major purchase.
3. Your DQT must have originally been purchased from an authorized AudioControl dealer. You do not have to be the original owner, but you do need a copy of the original sales slip.

AudioControl

4. You cannot let anybody who isn't (A) the AudioControl factory; (B) somebody authorized in writing by AudioControl to service your DQT. If anyone other than (A) or (B) messes with your DQT, that voids your warranty.

5. The warranty is also void if the serial number is altered or removed, or if DQT has been used improperly. Now that sounds like a big loophole, but here is all we mean by it.

Unwarranted abuse is (A) physical damage (don't use the DQT for a jack stand); (B) improper connections (120 volts into the power jack can fry the poor thing); (C) sadistic things. This is the best mobile product we know how to build, but if you mount it to the front bumper of your car, something will go wrong.

6. If an authorized United States AudioControl dealer installs DQT, the warranty is five years; otherwise the warranty is one year.

Assuming you conform to 1 through 6, and it really isn't all that hard to do, we get the option of fixing your old unit or replacing it with a new one.

LEGALESE SECTION

This is the only warranty given by AudioControl. This warranty gives you specific legal rights that vary from state to state. Promises of how well the DQT will perform are not implied by this warranty. Other than what we have covered in this warranty, we have no obligation, express or implied. Also, we will not be obligated for direct or indirect consequential damage to your system caused by hooking up the DQT.

Failure to send in a properly completed warranty card negates any service claims.

DQT SPECIFICATIONS

All specifications are measured at 14.4 VDC (standard automotive voltage). As technology advances, AudioControl reserves the right to continuously change our specifications, like our weather... although we are working on it.

Maximum input level	7.5 V _{rms}
Maximum output level	7.5 V _{peak}
Input gain	18 dB
Frequency response	10Hz-22kHz
Total harmonic distortion	0.01%
Signal to Noise ratio	-105dB
Balanced input noise rejection.....	60dB
Input Impedance	20 Kohms
Output Impedance	150 Ohms
Graphic Equalization Controls	30 bands 25 Hz - 20 kHz ISO 1/3 octave centers
Parametric Equalization Controls	2 bands 25 Hz - 20 kHz Adjustable centers
Parametric Equalization Bandwidth	1/12 - 3 oct
Equalization boost/cut	± 12 dB
Power supply	Isolated High headroom PWM switching
Power draw	600mA
Recommended fuse rating	2 Amp
Size	1.25" W x 9.9"D x 7"H
Weight	3.5 lbs

AudioControl

MENU TREE

Digital Fusion
by AudioControl (r)

Graphic EQ Freq=1kHz
L = 6dB >o< R = 4dB

Para EQ1 Freq=6.3k
Width = 1/6 LVL = 12dB

Para EQ2 Freq=3.15k
Width = 2oct LVL = +8dB

Memories Recall #7
Save

Display
Bright Dim

© 2002, AudioControl, a division of Electronic Engineering and Manufacturing, Inc. USA. All rights reserved

AudioControl, Making Good Stereo Sound Better, Digital Fusion, DQT, DXS, are all trademarks of Electronic Engineering and Manufacturing, Inc.

This manual was conceived, designed, and written on several bleak, windy, and dreary rain-drenched days at our home in the Pacific Northwest Rainforest. The latte's were hot and the Heffeweizen's were cold...like our weather.

Free Manuals Download Website

<http://myh66.com>

<http://usermanuals.us>

<http://www.somanuals.com>

<http://www.4manuals.cc>

<http://www.manual-lib.com>

<http://www.404manual.com>

<http://www.luxmanual.com>

<http://aubethermostatmanual.com>

Golf course search by state

<http://golfingnear.com>

Email search by domain

<http://emailbydomain.com>

Auto manuals search

<http://auto.somanuals.com>

TV manuals search

<http://tv.somanuals.com>