



AUDIOVOX™
CORPORATION

AS-RS

INSTALLATION MANUAL

FOR

Reverse Scanning System

Printed In USA

128-7073A

The Model AS-RS (Reverse Scanning System) reads ultrasonic signals that are projected from sensors mounted in your vehicle's rear bumper. As the signals "Echo" off of objects in the detection field, the control unit's microprocessor translates them into audible warning tones, or sounds, inside the vehicle which alert the driver. (An optional visual indicator is also available).

INSTALLATION INSTRUCTIONS

Recommended Tools for Installation

1. High torque drill suggested for use at **Slow Speed** of approximately **400 RPM**
2. Grease Pencil and Center Punch for marking drill point
3. 1/8" carbide-tipped drill bit for starting pilot hole (optional)
4. Hole Saw 28mm (1.1") - *Required (Part number AS-28MMHS)
5. Pliers for Scotch-Lok Connectors
6. Phillips head bit for drill (used to set self-tapping ground screw)
7. Multimeter
8. Zinc Galvanizer (Part number AS-RPMB) for protecting metal bumpers
9. Safety goggles
10. Angle Gauge Sleeve Selector (part number AS-SSAG)
11. Tape Measure

You may also wish to have on hand:

1. Panel tool (Optional - for situations requiring plastic, inner panels to be removed)
2. 3/8 Split Loom (use split loom to shroud sensor wires for a more factory appearance)
3. Wire pulling tool (for routing wires from vehicle's underside through to passenger compartment)
4. Rat-Tail metal file (for smoothing hole edges when necessary)- **DO NOT** use fingers to test holes for burrs or smoothness. **EDGES ARE SHARP!**

Installation Procedures-Where to Mount the Sensors

Before You Begin:

Inspect behind the bumper (fig. A.) in the approximate mounting area to check for any possible obstructions. For example check for 5 miles per hour collision struts or hardened metal braces that could prohibit drilling.

Proper installation will take into consideration two factors:

1. Placement: height and distance either side of bumper center.
2. Angle: accurate detection depends on the correct sensor angle.

The sensor needs 1" clearance space behind the bumper to allow the sensor to be fully inserted. Some bumpers have an outside cover or fascia and a metal backing. You may have to drill through both layers to insure you have enough clearance in order to install the sensors. Other bumpers may require some removal of the foam backing.

CAUTION: Be Careful of hot exhaust parts and/or sharp edges under bumper.

Determine the center of your bumper and mark the center using a grease pencil. Do not mount directly above exhaust pipe opening. From the center of the bumper measure outward to the location where you plan to mount your sensors. Mark the location with your grease pencil as shown in Fig. B. Ideal Range From Bumper Center: 14" to 18". Sensors should be mounted **NO LOWER THAN 18"** from the ground and **NO HIGHER THAN 30'** (fig. C.). Using a grease pencil, mark the final mounting location for the sensors.

NOTE: If bumper material is thicker than 5mm (0.2"), an external bracket will be required to mount the sensors.

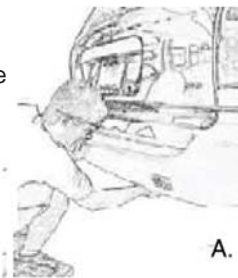

A.

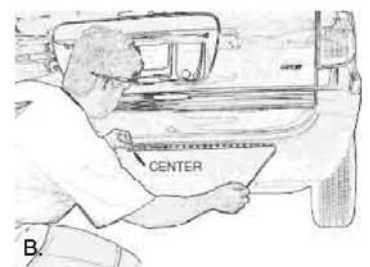

B.



C.

UniFit 2 Sensor System

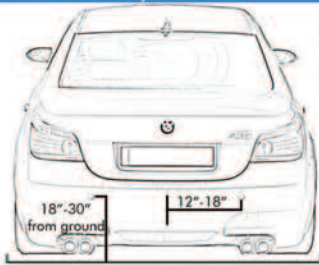

Ideal range for sensors is between 12"-18" from bumper center, and between 18"-30" from ground. Ports labeled CL and CR will be used for a 2 sensor hook-up.

UniFit 4 Sensor System

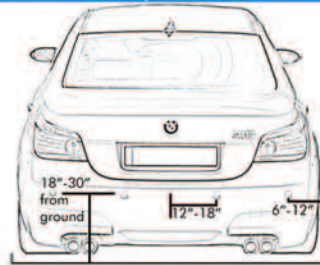

Ideal range for 4 sensors will be, 12"-18" from center of the bumper for the center sensors, and 6"-12" from the outer edge of bumper for the outer sensors. Ports labeled CL and CR will be used for the center sensors, and ports labeled L and R will be used for the outer sensors. (This is important because only the L and R ports have an adjustment for total distance detection, see P5-6 for details.) Distance from ground will be 18"-30".

WARNING: Please consult with Audiovox or an authorized dealer before installing the AS-RS on a vehicle with any rear-mounted external appliances. Spare tires, bike racks or other devices which may interfere with the reverse sensing system's detection area can cause false detection. Special installation instructions, procedures or warnings may apply.

How to Choose the Correct Sensor Angle Sleeve

The Sensor Angle Sleeve Selector (part no. AS-SSAG) makes installation of the reverse scanning system a snap! Before starting, make certain the vehicle is parked on flat and level ground and the parking brake is set. Next, make sure the swing-arm on the AS-SSAG is able to move freely by slightly loosening the pivot bolt. After you have determined where your sensor holes will be drilled and have marked the spot with a grease pencil, place the Sensor Sleeve Selector flat against the surface of the bumper with the arrow aligned with the dot you made (see illustration below). Make sure the arrow of the Sensor Sleeve Selector is perpendicular to the face of the bumper to obtain accurate results (see below).

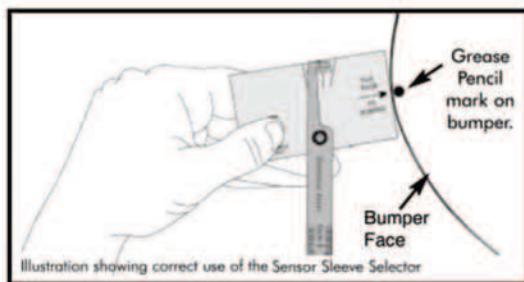

The Sensor Sleeve Selector will automatically and correctly determine which sensor sleeve (FO, F1, F2, or F3) you will need. "FO" sleeve is generally used for flat bumpers requiring no upward angle correction. If mounting height is 26" or more, you should be able to use an angle sleeve one number less than indicated. If your reading falls directly on a line, select the next sensor sleeve number to the right of the division line. The sensor sleeve is labeled at the top, 12 o'clock position either FO, F1, F2, or F3 to insure you select the proper angle sleeve according to the gauge marking.

Step 1: Drilling The Sensor Holes

Using the 28 mm hole saw (part #'s AS-28MMHS), cut the sensor holes. Always wear approved safety glasses when drilling. Caution should be used when cutting holes, as the Hole Saw, metal shavings and token shaped piece where hole is created will be very hot, and may have sharp edges. When drilling bumpers, only use the company approved cutting tool (part # AS-28MMHS). If drilling a metal bumper, coat edges of holes with Zinc Galvanizer (part # AS-RPMB) and allow a few minutes to dry. The Hole Saw tool is specifically designed for cutting through automotive bumper material, whether chrome-steel, plastic, or a combination of both. The sensor hole created by the AS-28MMHS matches the sensor shaft with great precision. Always create a dimple in the bumper prior to drilling to prevent slippage of the cutting tool.

Holes created in metal bumpers may have sharp burrs or edges which can damage your sensor wires. Remove burrs (if any) with a Rat-Tail metal file. Use care not to oversize sensor holes if filing. **DO NOT** use fingers to test holes for burrs or smoothness. **EDGES ARE SHARP!**

Step 2: Installing The Sensor Sleeve and Sensor

1. Press the pre-selected sleeve into the 28mm hole cut into the bumper, making sure that the alignment groove is in the 2 o'clock position.
2. Run the sensor wires through the sensor sleeves in the bumper.
3. Match alignment tab in 2 o'clock position on sensor sleeve with alignment groove on sensor and snap sensor into place. The "UP" mark on the sensor must be facing up. Be sure not to push on center of sensor. Push only on the outer plastic edge when securing the sensor into the sleeve. Sensor should fit snugly into the bumper and lock into place.

- Determine where the sensor wires will enter into the trunk area or passenger compartment. Many vehicles have a factory grommet to allow routing of wires from the outside to the inside of the vehicle. If you are drilling a hole through a metal body panel to route your sensor wires into the trunk/cargo area, be sure to coat the holes edges with Zinc Galvanizer.
- Feed the sensor wires through the factory grommet or other opening into the vehicle for connection to the control module (e.g., into the cab of most trucks or the trunk of passenger cars). Finish by fitting the hole with a rubber grommet, or by using automotive grade silicone to prevent moisture from entering the vehicle.

NOTE: Once the wires are passed through, ensure that you have the right amount of slack needed to route to the control module. Make sure that the sensor wires will not be pinched by moving parts or panels.
- Cable tie the sensor wires behind the bumper, away from any area that is close to the exhaust system or moving suspension parts. Do not pull or yank on the sensor wire were it exits the sensor shaft, as you may damage the inner connections.
- Cover the sensor wires with split-loom for a factory appearance.

Mounting the Adjustable Piezo Speaker and Optional LED

The piezo speaker has three adjustment positions: Hi, Low and Off. Therefore, you need to mount the piezo speaker to the vehicle interior where it can be easily accessed for adjustment.

- Route the plugs for both the speaker and optional LED to the area where you will install the control module. Make sure that they will not be pinched by any panels or moving parts.
- Clean the piezo speaker back mounting area with the supplied alcohol pad, remove the backing strip from the Velcro and firmly press the velcro pad onto the speaker back; then position the speaker into place on any fibrous cloth surface, or mount with the screws supplied.
- Attach the optional LED using the supplied brackets and double-sided adhesive foam pad, making sure it is in view through the rear-view mirror, or rear center of the vehicle drivers line-of-sight.

NOTE: Do not mount speaker or optional LED in direct sunlight.

Mounting the control module.

Determine a dry place inside the vehicle (which will be out of the way) to mount the control module (e.g., behind an inner body panel), making sure that all wiring will reach its intended location.

- Plug the sensor wires, piezo speaker and power harness into the control module before mounting.

NOTE: The control module is pre-fitted with 3M Velco for mounting.

- Clean the pre-selected mounting area with the alcohol pad provided to ensure good adhesion.
- When surface is dry, peel off the backing of the Velco pad and stick the control module in place.

Connecting the Power Harness to the vehicle:

Determine where the reverse light wire is located. There are two methods of quickly and easily locating the reverse light power wire:

CAUTION: Set the parking brake. The ignition key must be in the on position, but do not test with the engine running.

- The first method is to actually remove the tail light housing from the vehicle. On many vehicles, this can be done by simply removing 2 to 3 screws or bolts, and using light finger pressure to remove the assembly. Once the tail light housing is removed, examine where the wires plug in to the back of the light housing. The target wire will have +12 volts when the vehicle is in the reverse position, and 0 volts in any other gear position.
- The second method also involves the use of a 12 volt multimeter. Probe the appropriate wiring harness which heads toward the reverse light connector of the vehicle, looking for the wire which carries +12 volts when reverse gear is engaged, and no voltage when reverse gear is disengaged.

Never use a test light to probe wires.

Once you have located the proper reverse light power wire, use pliers to connect the RED wire from the unit's power harness using the provided 3M Scotch-Lock connector. Make sure you have a solid connection. A poor quality connection for power or ground may cause intermittent or no operation. Connect the black, ground wire from the unit's wiring harness to the vehicle's chassis, using the provided ring terminal connector, star washer and self-tapping screw.



Testing the Installation.

The key to successful testing starts with the right test environment. The ideal test environment should be:

1. Outside on Flat / Level ground.
2. Free from obstructions 8 feet from the rear of the vehicle.
3. Free from obstructions to the sides of the bumper.
4. Free from objects laying on the ground in the area described above.

Immediately after turning on the ignition, you will hear one quick beep. If there are no obstructions behind the vehicle (within 6 feet), and no obstructions on the ground, the speaker should now be silent. **Test the unit with the engine OFF** as follows:

1. Set the vehicles Emergency Brake and block the tires whenever possible.
2. Turn the vehicles ignition key to the ON position (but do not start engine).
3. Select Reverse Gear. You should hear one beep, indicating you have engaged reverse gear, and the system is scanning for objects in the detection field. If it detects that a sensor is disconnected it will beep one additional beep for each disconnected sensor.
4. Roll down the windows, so you can hear the speaker from outside the vehicle (set to Hi volume if desired).

For testing purposes, you may wish to hold a piece of flat, reflective material in your hand (such as medium sized piece of cardboard). From a distance of about 8 feet, slowly begin walking toward the vehicle, holding the reflector parallel to the bumper. At approximately 6 feet, the system should begin to beep slowly, indicating that you have been detected in Zone 1'.

Continue slowly approaching the bumper, at a distance of approximately 4 feet from the vehicle, the beeping will quicken to 3 times-per-second, indicating you have been detected in Zone 2.

As you approach 2 feet from the rear bumper, the warning tone will be continuous, indicating you have been detected in Zone 3.

*When testing, do not start vehicle, reverse may be selected with key in and turned to the on position without car running (do not crank starter).

Installation Guide Troubleshooting and Tech Tips (For Trained Technicians Only)

Condition	Cause / Action
No Power Sensors do not detect objects No sound from speaker	<ul style="list-style-type: none">•Check ground and power connection•Check if proper power source is tapped (reverse wire)•Speaker wire plugged in and is not in Hi or Lo setting•Control Module not working properly•Speaker not working properly
Zone 1 Constant Zone 2 Constant Zone 3 Constant	<ul style="list-style-type: none">•Check for objects within 6 feet of vehicle•Sensors mounted too low or improper sleeve used•Testing surface too rough, such as gravel or snow•Unplug one sensor at a time to isolate the false signal's source as far as which sensor is causing the false signal

For Additional assistance call: 1-800-225-6074

Understanding your Reverse Scanning System's Audible Warning zones

Your system reads ultrasonic signals that are projected from sensors mounted in your vehicle's rear bumper. As the signals "Echo" off of objects in the detection field, the control unit's microprocessor translates them into audible warning tones, or sounds, inside the vehicle, which alert the driver. (An optional visual indicator is also available).

Your reverse sensor system will detect in three distinct "Zones", which correspond with your vehicle's distance to the object. The moment you engage reverse gear, you should hear one quick beep, indicating all sensors are functional. This alert serves additional purposes:

1. Notification that the system has activated and is scanning for objects in the detection field.
2. As a reminder that you have selected reverse gear.
3. As an indication that your reverse sensing system has performed a self-check.

*If additional "quick beeps" sound, your system may need to be checked, If warning tones continue after startup, check for obstacles behind the vehicle.

If you are reversing towards a wall or large, flat object, at a distance of approximately 6 feet your reverse scanning system will begin to beep slowly indicating an object in "Zone 1".

At a distance of approximately 4 feet, your reverse scanning system will beep 3 times-per-second, indicating an obstacle in "Zone 2".

When the warning tone becomes solid, you have entered "Zone 3", indicating there is an object within 2 feet of your vehicle's bumper.

Use extreme caution in Zone 2, and always stop when you hear a solid tone indicating Zone 3. If a moving object enters zone 3, the system will "lock" onto it, making zone 3 tone constant, until the object is a safe distance from zone 3; i.e., moves 2 feet outside of the zone 3 detection area.

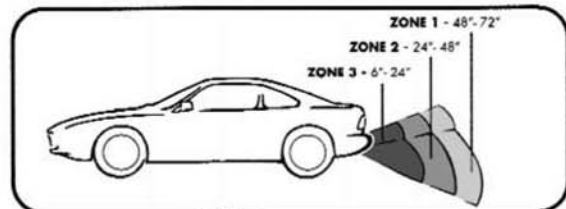

Reverse Scanning System Detection Zones

Your system senses objects behind your vehicle using an ultrasonic "detection pattern". This pattern varies depending on your sensor configuration. Understanding the parameters of your detection pattern will make your driving experience safer and enable you to get the best use of your reverse scanning system.

Objects entering into the "detection pattern" will cause your unit to give an audible warning tone. Each individual sensor's detection pattern is approximately 6 feet long by 4 feet wide. For most accurate results sensors should be installed appropriately on the vehicle so that coverage is maximized while allowing for some overlap of sensor detection zones.

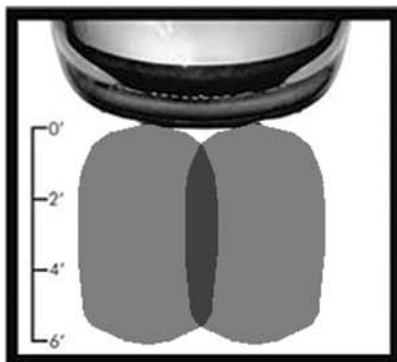

Passenger vehicle setup with standard 2 sensor configuration. Approx. 6' central detection pattern by 5-8 feet wide depending on installation. CL & CR ports used.

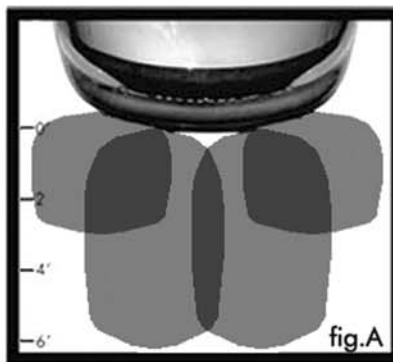

Optional 4 sensor configuration. Approximately 6' of central coverage and selectable outer coverage ranges of 3' (fig.A) or 6' (fig.B). Center sensors use CL & CR ports and outer sensors use L & R ports. (fig.A is a passenger vehicle option and fig.B is a commercial option)

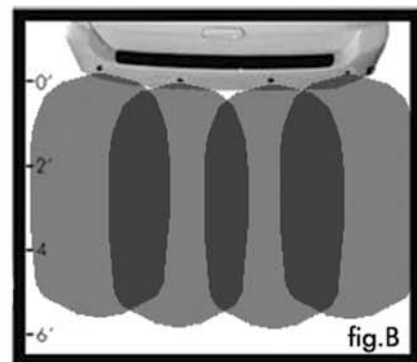

*Grey areas above represent where sensors have "double" or overlapping detection areas. This has no negative effect on system performance or detection it is only to aide in visualization of the system set up.

Adjusting your Piezo Speaker

Your reverse scanning system comes equipped with an adjustable warning indicator speaker to suit your individual needs.

- Hi Volume Settings:** For larger vehicles, or SUVs with long wheel bases, where the speaker is located at the back of the passenger compartment, or for those desiring a louder warning tone.
- Low Volume Settings:** For smaller vehicles, or those desiring a softer warning tone.
- Off:** Used when towing a trailer package.

NOTE: if your system is equipped with the optional LED display it will remain on. It is not designed to be powered off and on. Adjusting your volume setting is easy. Simply move the fingertip slider switch to select the desired setting (see diagram).



Optional LED Display:

All lights on the display will flash a visual warning in unison with the warning speaker.

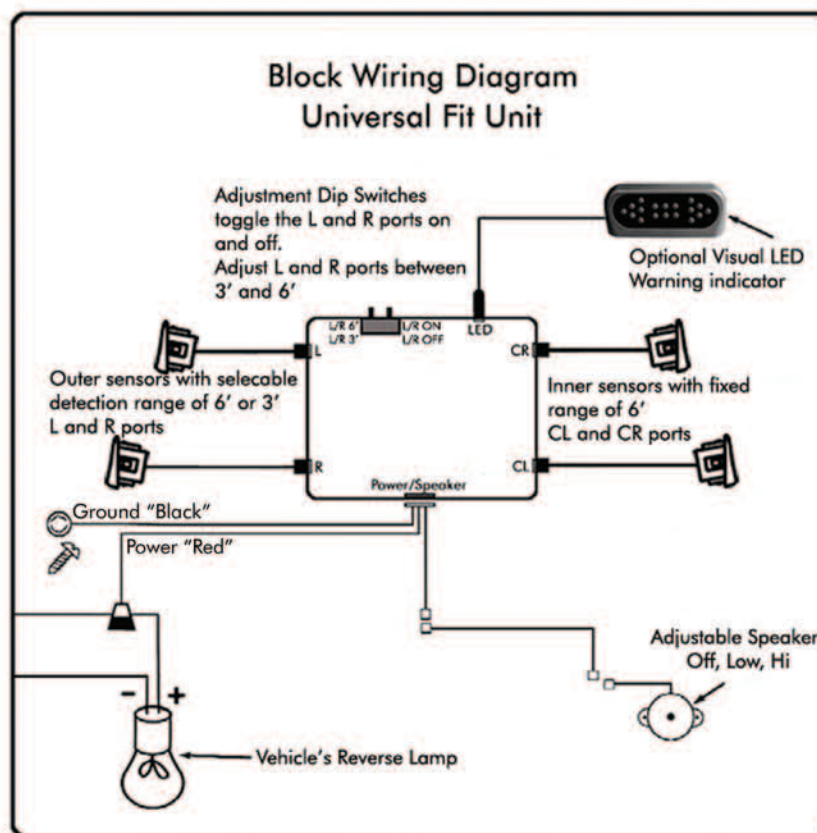

Dip Switch Settings and their corresponding functions. (CL and CR ports are always operational regardless of dip switch position)

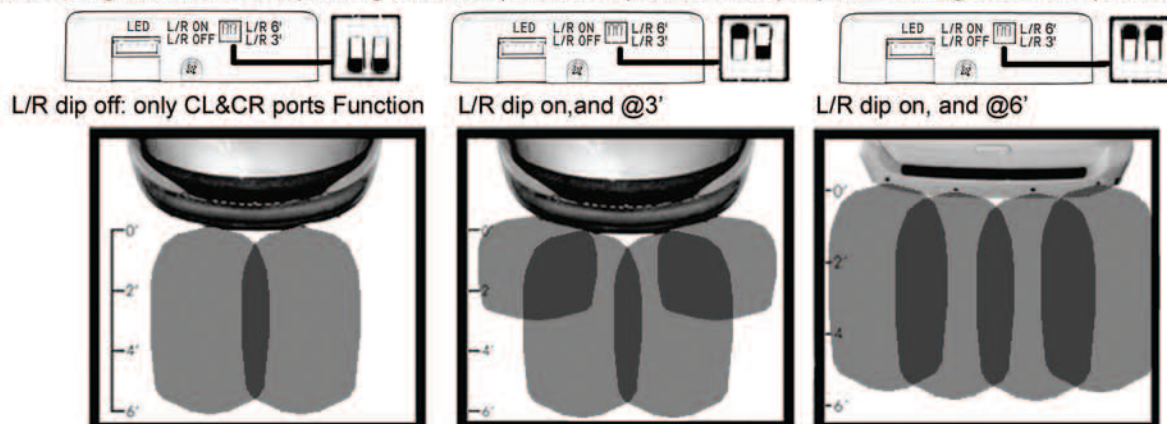



For Customer Service
Visit Our Website At
www.audiovox.com
Product Information, Photos,
FAQ's Owner's Manuals

© 2005 Audiovox Electronics Corp., Hauppauge, NY 11788

Printed in USA

128-7073A

Free Manuals Download Website

<http://myh66.com>

<http://usermanuals.us>

<http://www.somanuals.com>

<http://www.4manuals.cc>

<http://www.manual-lib.com>

<http://www.404manual.com>

<http://www.luxmanual.com>

<http://aubethermostatmanual.com>

Golf course search by state

<http://golfingnear.com>

Email search by domain

<http://emailbydomain.com>

Auto manuals search

<http://auto.somanuals.com>

TV manuals search

<http://tv.somanuals.com>