



Model APS-101N

Installation Manual

Programmable Features

<u>Select By Operating Transmitter</u>	Press Lock Button	Press Unlock Button	
<u>Siren Indications</u>	<u>1 Chirp</u>	<u>2 Chirps</u>	<u>Factory Default</u>
1) Arming Method	Passive Arm	Active Arm	Passive Arm
2) Ignition Control Lock/Unlock	Off	On	Off
3) Passive Or Active Door Locks	Active	Passive	Active
4) Single Or Double Pulse U/L	Single Pulse	Double Pulse	Single
5) Door Lock/Unlock Pulse Duration	1 Second	3 Seconds	1 Second
6) Siren Chirps On/Off	On	Off	On
7) Passive Rearm From Active State	On	Off	On

To Program The Following Selectable Features:

1. Enter the vehicle and turn the ignition key to the on position.
2. Press and release the valet/override/program push button switch 3 times.
Siren Chirps Once & Led Flash Once
3. Within 3 seconds, turn the ignition off than on, you will hear short chirp followed by long chirp.
4. Press and release the valet pushbutton switch one time to access feature #1. Use transmitter buttons to change, or press the valet pushbutton switch to advance to the next feature. Turn the ignition switch off, or allow 60 seconds of inactivity to exit the feature program mode.

NOTE: While in the program mode, if the ignition switch is turned off, or if 60 seconds of inactivity expire the program mode will terminate, indicated by one short and one long chirp of the siren.

INSTALLATION OF THE MAIN COMPONENTS

Control Module :

Select a mounting location inside the passenger compartment (up behind the dash), and secure using the two screws provided. The control module can also be secured in place using cable ties. Keep in mind that the module has the on-board Shock Sensor and should be mounted to a fairly rigid location to insure proper operation.

Do not mount the control module in the engine compartment, as it is not waterproof. You should also avoid mounting the unit directly onto factory installed electronic components. These components may cause RF interference, which can result in poor transmitter range or intermittent operation.

Siren:

Select a mounting location in the engine compartment that is well protected from access below the vehicle. Avoid areas near high heat components or moving parts within the engine compartment. To prevent water retention, the flared end of the siren must be pointed downward when mounted.

Mount the siren to the selected location using the screws and bracket provided.

Hood or Trunk Pin Switch:

A pin switch, not included, is intended for use in protecting the hood or trunk (or hatchback) of the vehicle. The switch must always be mounted to a grounded, metal surface of the vehicle. It is important to select a location where water cannot flow or collect, and to avoid all drip gutters on hood and trunk fender walls. Choose locations that are protected by rubber gaskets when the hood or trunk lid is closed.

The pin switch can be mounted to a bracket, or direct mounting. Keep in mind that when properly mounted, the plunger of the pin switch should depress at least ¼ " when the hood or trunk lid is closed.

Dash Mounted LED:

A small red LED is included that will serve as a visual indicator of the alarm status. It should be installed in the dash, located where it can be easily seen from outside the vehicle, yet not be distracting to the driver.

Once a location has been selected, check behind the panel for wire routing access, and to confirm the drill will not damage any existing components as it passes through the panel.

Drill a ¼ " diameter hole, and pass the red and blue wires from the LED through the hole, from the front of the panel. Firmly press the body of the LED into the hole until fully seated.

Valet/Programming Switch:

Select a covert location for this switch within reach of the driver of the vehicle. This switch can be mounted below a dash panel, under the driver's seat. This switch must be within reach of the operator of the vehicle. The locations mentioned are hidden from view and will be known only to the vehicle operator yet they allow activation of the switch when necessary.

WIRING THE SYSTEM

5 Pin Main Connector:

Red Fused Wire: 15 Amp Fused Parking Light Input.

This wire supplies the source for the On-Board Parking Light Relay. If the vehicle's circuit switches + 12 Volts to the parking light circuit, connect this wire to a 12 volt source capable of 15 Amps.

If the vehicle's parking light circuit switches ground to the parking light circuit, then connect this wire to a Ground Source.

White Wire: Parking Light Output (10 Amp Max)

This wire is provided to flash the vehicle's parking lights. Connect the white wire to the positive side of one of the vehicle's parking lights.

Black Wire: Chassis Ground

Connect this wire to a solid, metal part of the vehicle's chassis. Do not confuse this wire with the thin black antenna wire that exits the control module independently.

White w/ Black Trace Wire: Positive Output to Siren

Route this wire through a rubber grommet in the firewall, and to the siren location.

Connect the white / black wire to the positive wire of the siren. Secure the black ground wire of the siren to chassis ground.

Red/White Wire: + 12 VDC Circuit Supply.

This 5 Amp fused wire supplies + 12 volts to the module circuit. Connect this wire to a constant 12 volt source capable of at least 10 Amps.

6 Pin Input/Output Harness

Purple Wire: + DOOR TRIGGER

If the vehicle's door courtesy light switches have a + 12 volt output when the door is opened (most Fords and some Imports), you must connect this wire to the positive output from one of the door switches. In most cases, the purple wire will only needs to be connected to one door switch, no matter how many doors the vehicle has.

WARNING: Do not use the purple wire if the vehicle has ground output type door switches. (See Brown Wire.)

NOTE: For vehicles with interior delay lighting see programming under title "Completing The Installation".

Dark Green Wire: (-) Instant Trigger Zone

This is an instant on ground trigger wire. It must be connected to the previously installed hood and trunk pin switches.

Brown Wire: - DOOR TRIGGER

If the vehicle's courtesy light switches have a (-) ground output when the door is opened (GM and most Imports), you must connect this wire to the negative output from one of the door switches.

WARNING: Do not use the brown wire if the vehicle has + 12 volt output type door switches. (See Purple Wire.)

Note: For vehicles with interior delay lighting see programming under title "Completing The Installation".

Yellow Wire: + 12 VDC IGNITION SOURCE

Connect this wire to a source that is live when the key is in the on and crank positions. Be sure that this source is off when the key is in the off position.

Orange Wire: 300 mA GROUND OUTPUT WHEN ARMED - N. C. STARTER DISABLE

This wire is provided to control the starter cut relay. Connect the orange wire to terminal 86 of the relay. Connect relay terminal 85 to an ignition wire in the vehicle that is live when the key is in the on and crank positions, and off when the key is in the off position. (This is where the yellow wire from the alarm should be connected).

Cut the low current starter solenoid wire in the vehicle, and connect one side of the cut wire to relay terminal 87A. Connect the other side of the cut wire to relay terminal 30.

NOTE: This is a normally closed starter cut arrangement, and when power is removed from the security system, the starter disable feature will not operate, allowing the vehicle to start. Audiovox does not recommend using the Orange wire to interrupt anything but the starting circuit of the vehicle.

Dark Blue Wire: DELAYED 200 mA PULSED OUTPUT / CHANNEL 2

The dark blue wire pulses to ground via an independent RF channel from the keychain transmitter. This is a transistorized, low current output, and should only be used to drive an external relay coil.

WARNING: Connecting the dark blue wire to the high current switched output of trunk release circuits, and some remote start trigger inputs, will damage the control module.

In these cases connect the dark blue wire to terminal 86 of the AS-9256 relay (or equivalent 30 A automotive relay), and wire the remaining relay contacts to perform the selected function of channel 2.

2 Pin White Connector: DASH MOUNTED LED

Route the red and blue wires in the 2 pin white connector from the LED to the control module and plug it into the mating white connector on the side of the module.

2 Pin Blue Connector: VALET / PROGRAMMING SWITCH

Route the 2 pin blue connector from the override switch previously mounted to the mating two pin connector on the module.

Red / Green / Red w/Black Trace 3 Pin White Connector: Door Lock Outputs

The Red and Green wires will provide a pulsed ground output to the factory door lock control relay. The maximum current draw through these outputs must not exceed 200 mA. The Red w/Black trace wire will provide a pulsed ground when the unlock button of the transmitter is pressed a second time after a first unlock command was issued. This is used for second step unlock or all doors unlock in a two step circuit. In this arrangement Red or Green is used to control the drivers door unlock relay, and the Red/Black will be used to control unlock of all other doors.

3 Wire Ground Switched Single Step Door Locks

In this application, the **red wire** provides a ground pulse during arming, or the **pulsed ground lock** output. Connect the red wire to the wire that provides a low current ground signal from the factory door lock switch to the factory door lock control relay.

The **green wire** provides a ground pulse during disarming, or the **pulsed ground unlock** output. Connect the green wire to the wire that provides a low current ground signal from the factory door unlock switch to the factory door unlock control relay.

Red/Black Not Used.

3 Wire Ground Switched 2 Step Door Locks

In this application, the **red wire** provides a ground pulse during arming, or the **pulsed ground lock** output. Connect the red wire to the wire that provides a low current ground signal from the factory door lock switch to the factory door lock control relay.

The **green wire** provides the first ground pulse during disarming, or the **drivers door pulsed ground unlock** output. Connect this wire to the **drivers door unlock** relay that requires a low current ground signal to unlock only the drivers door. If the vehicle does not have a separate drivers door relay, one will have to be added. Locate the drivers door unlock motor wire and cut it at a convenient location to allow wiring of an optional relay. Connect the door side of the cut wire to terminal 30 of the optional relay added. Connect the vehicle side of the cut wire to terminal 87a of the optional relay added. Connect the green wire of the 3 pin harness to terminal 86 of the optional relay added. Connect terminal 85 of the optional relay added to a fused constant + 12 volt source. Most vehicles door lock/unlock motor legs rest at ground, and switch +12 volts to the door lock/unlock motor legs for operation, if this is the case in the vehicle you are working on, connect the remaining terminal, 87, to a fused + 12 volt source. In the rare instance that the vehicle door lock/unlock motor legs rest at + 12 volts and switches ground to the door lock/unlock motors, connect the remaining terminal, 87, to chassis ground.

The **Red/Black wire** provides a pulse ground output when the unlock button of the transmitter is pressed a second time after disarming. Connect the Red/Black wire to the wire that provides a low current ground signal from the factory door unlock switch to the factory door lock control relay.

Resistive Circuits, As Well As 4 Wire Polarity Reversal and 5 Wire Alternating 12 Volt

Door Lock Control Circuits

These applications require the use of additional components which may include relays, fixed resistors, or for convenience, the AS 9159a Door Lock Interface. Refer to the AUDIOVOX Door Lock Wiring Supplement and or the Audiovox fax back service for information on your particular vehicle for properly connecting to these types of circuits.

COMPLETING THE INSTALLATION

NOTE: This unit has the ability to learn the dome light delay time, up to 60 seconds. If the vehicle has delay interior lights, and you wish to avoid three chirp, defect zone, indication normally associated with this type of interior light, we suggest you learn the interior light delay.

To learn the light delay, start with all doors closed:

- (1) Use the transmitter to Lock / Unlock / Lock / Unlock / Lock / Unlock / Lock, the system.
The LED turns on solid to confirm the system entered the learn mode.
- (2) Immediately open and close the door of the vehicle to initiate the dome delay.
The unit will monitor the door trigger input Positive, (Purple), and Negative, (Brown) when active.
When the dome light turns off, the unit will add 2 seconds then exit the learn mode.
- (3) The LED will begin flashing the Armed indication indicating the unit has exited the learn mode and is armed.

Antenna Wire : Be sure to extend the thin black antenna wire to it's full length, and cable tie into place where it cannot be damaged. Avoid wrapping this wire around major, high current wire looms.

On-Board Shock Sensor Setting:

1. Enter the vehicle, and turn the ignition key to the "on" position.
2. Press and release the valet/override/program push button switch 3 times. Siren Chirps Once & Led Flash Once
3. Turn the ignition off than on, you will hear short chirp followed by long chirp.
4. Turn the ignition off then on, you will hear two long chirps indicating that you are in the shock adjust mode.
5. Press the lock button to increase, and the unlock button to decrease. The siren will chirp 1-14 times 1 being lowest and 14 being highest. Firmly strike the bumper of the vehicle during the adjustment mode until you find the desired level for the Full Trigger Stage.
6. Press both the lock & unlock buttons of the transmitter simultaneously until the siren emits two long siren chirps indicating that you are in the Pre-Detect adjust stage.
7. Press the lock button to increase, and the unlock button to decrease. The siren will chirp 1-14 times 1 being lowest and 14 being highest. Firmly strike the bumper of the vehicle during the adjustment mode until you find the desired level for the Pre-Detect Stage.

Once you have achieved the desired setting, either turn the ignition off or allow 60 seconds of inactivity to expire to exit the Shock Adjust Mode. Exit of the shock adjust mode is indicated by the siren emitting 3 long chirps.

CAUTION: Never perform this test on the vehicle's glass, as you may break the window.

WARNING! Setting the sensitivity too high can cause false alarms due to noise vibrations from passing trucks and heavy equipment. To decrease sensitivity, follow steps 1-5 above and use the trunk/key button to decrease.

Wire Dressing: Always wrap the alarm wires in convoluted tubing, or with a spiral wrap of electrical tape. Secure these looms along the routing using cable ties. This will ensure that the alarm wires are not damaged by falling onto hot or sharp moving surfaces in the vehicle.

Operation: Take a few moments to check off the appropriate option boxes in the owner's manual, and to fully explain the operation of the system to your customer.

THIS PAGE LEFT BLANK INTENTIONALLY

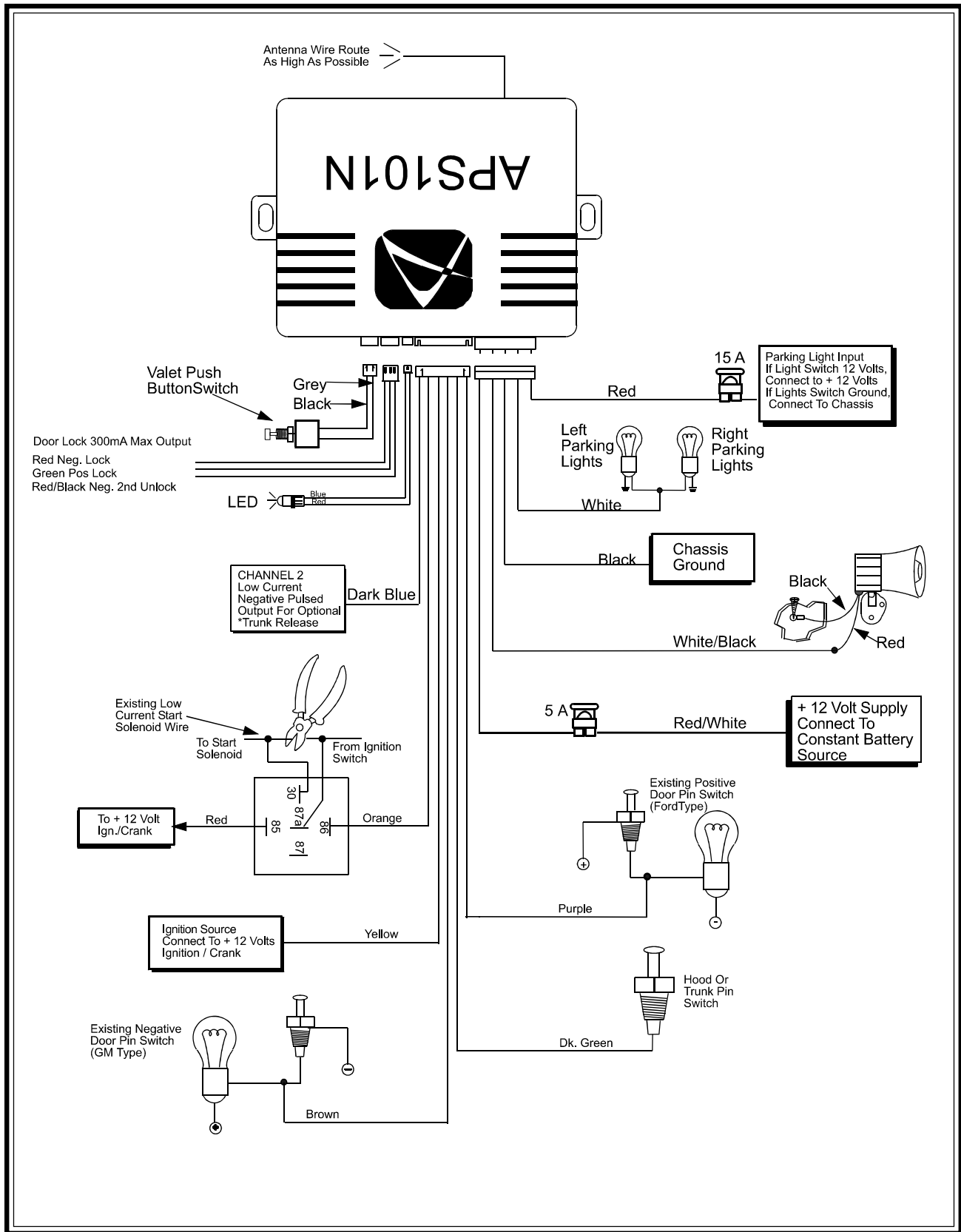

THIS PAGE LEFT BLANK INTENTIONALLY

© 2009 Audiovox Electronics Corporation, 150 Marcus Blvd., Hauppauge, NY 11788

128-8615

Free Manuals Download Website

<http://myh66.com>

<http://usermanuals.us>

<http://www.somanuals.com>

<http://www.4manuals.cc>

<http://www.manual-lib.com>

<http://www.404manual.com>

<http://www.luxmanual.com>

<http://aubethermostatmanual.com>

Golf course search by state

<http://golfingnear.com>

Email search by domain

<http://emailbydomain.com>

Auto manuals search

<http://auto.somanuals.com>

TV manuals search

<http://tv.somanuals.com>