

Avanti®

INSTRUCTION MANUAL MANUAL DE INSTRUCCIONES

Model Number/ No. de Modelo: WC492D

**WINE/BEVERAGE COOLER
(ENFRIADOR DE VINO Y CERVEZA)**

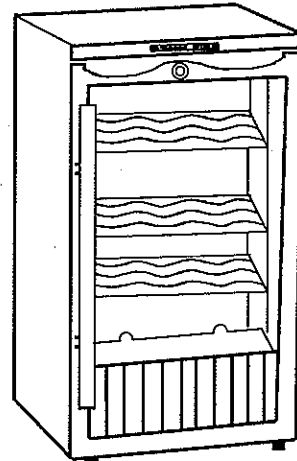

CAUTION:

**BEFORE USE, PLEASE READ AND FOLLOW ALL SAFETY RULES
AND OPERATING INSTRUCTIONS.**

La sección en español empieza en la página 13.

Avanti Products has a policy of continuous improvement on its products and reserves the right to change materials and specifications without notice.

Avanti Products
P. O. Box 520604 – Miami, Florida 33152
www.avantiproducts.com

Registration Information

Thank you for purchasing this fine Avanti product. Please fill out this card and return it within 100 days of purchase and receive these important benefits:

➤ **Protect your product:**

We will keep the model number and date of purchase of your new Avanti product on file to help you refer to this information in the event of an insurance claim such as fire or theft.

➤ **Promote better products:**

We value your input. Your responses will help us develop products designed to best meet your future needs.

----- (detach here) -----

Avanti Registration Card

Name			Model#	Serial#
Address			Date Purchased	Store/Dealer Name
City	State	Zip	Occupation	
Area Code			Phone Number	
Did You Purchase An Additional Warranty:			Your Age:	
<input type="checkbox"/> Extended <input type="checkbox"/> None			<input type="checkbox"/> under 18 <input type="checkbox"/> 18 - 25 <input type="checkbox"/> 26 - 30	
Reason For Choosing This Avanti Product:			<input type="checkbox"/> 31 - 35 <input type="checkbox"/> 36 - 50 <input type="checkbox"/> over 50	
Please indicate the most important factors that influenced your decision to purchase this product.			Marital Status:	
<input type="checkbox"/> Price			<input type="checkbox"/> Married <input type="checkbox"/> Single	
<input type="checkbox"/> Product Features			Is This Product Used In The:	
<input type="checkbox"/> Avanti Reputation			<input type="checkbox"/> Home <input type="checkbox"/> Business	
<input type="checkbox"/> Product Quality			How Did You Learn About This Product:	
<input type="checkbox"/> Salesperson Recommendation			<input type="checkbox"/> Advertising <input type="checkbox"/> Personal Demo	
<input type="checkbox"/> Friend/Relative Recommendation			<input type="checkbox"/> In Store Demo	
<input type="checkbox"/> Warranty			<input type="checkbox"/> Other _____	
<input type="checkbox"/> Other _____			Comments _____	

HELP US HELP YOU...

Read this guide carefully.

It is intended to help you operate and maintain your new Wine/Beverage cooler properly.

Keep it handy to answer your questions. If you don't understand something or you need more assistance, please call:

Avanti Customer Service
800 - 220 - 5570

Keep proof of original purchase date (such as your sales slip) with this guide to establish the warranty period.

CAUTION:
THIS WINE/BEVERAGE COOLER IS NOT DESIGNED FOR THE STORAGE OF MEDICINE OR OTHER MEDICAL PRODUCTS.

Write down the model and serial numbers.

You'll find them on a plate located on the bottom outside wall of the Wine/Beverage Cooler.

Please write these numbers here:

Date of Purchase

Model Number

Serial Number

Use these numbers in any correspondence or service calls concerning your Wine/Beverage Cooler.

If you received a damaged Wine/Beverage Cooler, immediately contact the dealer (or builder) that sold you the Wine/Beverage Cooler.

Save time and money. Before you call for service, check the Troubleshooting Guide. It lists causes of minor operating problems that you can correct yourself.

IF YOU NEED SERVICE

We're proud of our service and want you to be pleased. If for some reason you are not happy with the service you receive, here are some steps to follow for assistance.

FIRST, contact the people who serviced your Wine/Beverage Cooler. Explain why you are not pleased. In most cases, this will solve the problem.

NEXT, if you are still not pleased, write all the details, including your telephone number, and send it to:

Customer Service
Avanti Products
10880 NW 30 Street
Miami, FL 33172

Table of Contents

Registration Information	1
Help Us Help You	2
Parts and Features	4
Important Safety Instructions	5
Installation Instructions	5
Before Using Your Wine/Beverage Cooler	5
Installation of Your Wine/Beverage Cooler	5
Electrical Connection	6
Operating Your Wine/Beverage Cooler	7
Setting the Temperature Control	7
Cleaning Your Wine/Beverage Cooler	7
Vacation Time	8
Moving Your Wine/Beverage Cooler	8
Energy Saving Tips	8
Troubleshooting Guide	9
Service For Your Wine/Beverage Cooler	10
Your Avanti Products Warranty	11
Wiring Diagram	12
INSTRUCCIONES EN ESPAÑOL	13 - 16

Parts & Features

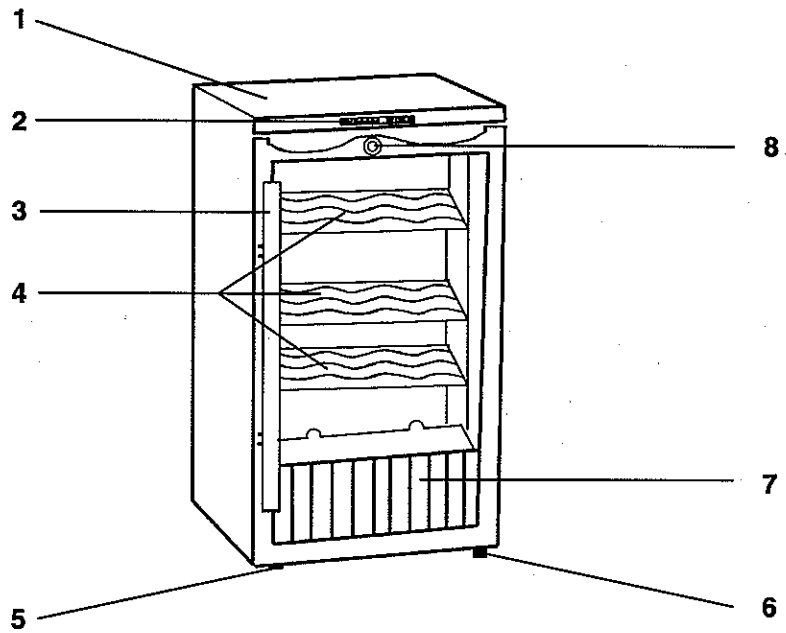

- 1 Countertop
- 2 Digital Readout
- 3 Handle
- 4 Chrome Shelves
- 5 Leveling Leg
- 6 Adjustable Leg
- 7 Bottle Rack
- 8 Lock Assembly

Important Safety Instructions

⚠ WARNING ⚠	To reduce the risk of fire, electrical shock, or injury when using your appliance, follow these basic precautions:
<ul style="list-style-type: none">• Read all instructions before using the appliance.• Danger or warning: risk of child entrapment.• Before you throw away your old refrigerator or freezer: take off the doors. Leave the shelves in place so that children may not easily climb inside.• Never allow children to operate, play with, or crawl inside the refrigerator.• Never clean refrigerator parts with flammable fluids. The fumes can create a fire hazard or explosion.• Do not store or use gasoline or any other flammable vapors and liquids in the vicinity of this or any other refrigerator. The fumes can create a fire hazard or explosion.	
– Save these instructions –	

INSTALLATION INSTRUCTIONS

➤ Before Using Your Wine/Beverage Cooler

- Remove the exterior and interior packing including protective film on door panel and digital display.
- Check to be sure you have all of the following parts:
 - 6 Shelves
 - 2 Keys
 - 1 Basket
 - Instruction Manual
- Before connecting the Wine/Beverage Cooler to the power source, let it stand upright for approximately 2 hours. This will reduce the possibility of a malfunction in the cooling system from handling during transportation.
- Clean the interior surface with lukewarm water using a soft cloth.

➤ Installation of Your Wine/Beverage Cooler

- This appliance is designed to be free standing only, and should not be recessed or built-in (fully recessed).
- Place your Wine/Beverage Cooler on a floor that is strong enough to support it when it is fully loaded. To level your Wine/Beverage Cooler, adjust the front legs at the

bottom of the unit.

- Allow 5 inches of space between the back and sides of the unit, which allows the proper air circulation to cool the compressor.
- Locate the Wine/Beverage Cooler away from direct sunlight and sources of heat (stove, heater, radiator, etc.) . Direct sunlight may affect the acrylic coating and heat sources may increase electrical consumption. Extreme cold ambient temperatures may also cause the unit not to perform properly.
- Avoid locating the unit in moist areas.
- Plug the Wine/Beverage Cooler into an exclusive, properly installed – grounded wall outlet. Do not under any circumstances cut or remove the third (ground) prong from the power cord. Any questions concerning power and/or grounding should be directed toward a certified electrician or an authorized Avanti Products service center.
- After plugging the appliance into a wall outlet, allow the unit to cool down for 2 – 3 hours before placing items in the compartment.

➤ Electrical Connection

⚡ Warning ⚡

Improper use of the grounded plug can result in the risk of electrical shock. If the power cord is damaged, have it replaced by an authorized Avanti Products service center.

This appliance should be properly grounded for your safety. The power cord of this appliance is equipped with a three – prong plug which mates with standard three prong wall outlets to minimize the possibility of electrical shock.

Plug the appliance into an exclusive properly installed – grounded wall outlet. Do not under any circumstances cut or remove the third (ground) prong from the power cord. Any questions concerning power and/or grounding should be directed toward a certified electrician or an authorized Avanti Products service center.

This appliance requires a standard 115/120 – volt/60Hz electrical outlet with three – prong ground.

The cord should be secured behind the appliance and not left exposed or dangling to prevent accidental injury.

Do not use an adapter plug with this appliance.

Do not use an extension cord with this appliance. If the power cord is too short, have a qualified electrician or service technician install an outlet near the appliance.

OPERATING YOUR WINE/BEVERAGE COOLER

➤ Setting the Temperature Control

- You can set the temperature as you desire by pushing the button **A** or **D** when you push the two buttons for the first time, the LED readout will show the original temperature set at previous time (the temperature preset at the factory is 50°F)
- The temperature that you desire to set will increase 1°F or 1°C if you push the **A** once, on the contrary the temperature will decrease 1°F or 1°C if you push the **D** once.

BEER: FOR BEER OR SODA CANS

SPARKL: SPARKLING WINES/ROSE WINES

WHITE: WHITE WINES/DRY

RED: RED WINES



NOTE: WHEN USING FOR BOTH WINE AND BEER SIMULTANEOUSLY WE RECOMMEND THAT YOU PLACE RED WINE BOTTLES ON TOP SHELF AND BEER ON BOTTOM SHELF.

➤ Reversing the Door Swing of Your Appliance

This appliance has the capability of the door opening from either the left or right side. The unit is delivered to you with the door opening from the left side. Should you desire to reverse the opening direction, please call service for reversal instructions.

➤ Cleaning Your Wine/Beverage Cooler

- Turn the temperature control to "OFF", unplug the Wine/Beverage Cooler, and remove all items including shelves and trays.
- Wash the inside surfaces with a warm water and baking soda solution. The solution should be about 2 tablespoons of baking soda to a quart of water.
- Wash the shelves and trays with a mild detergent solution.
- The outside of the Wine/Beverage Cooler should be cleaned with mild detergent and warm water.
- Wring excess water out of the sponge or cloth when cleaning area of the controls, or any electrical parts.
- Wash the outside cabinet with warm water and mild liquid detergent. Rinse well and wipe dry with a clean soft cloth.

➤ **Vacation Time**

- **Short vacations:** Leave the Wine/Beverage Cooler operating during vacations of less than three weeks.
- **Long vacations:** If the appliance will not be used for several months, remove all items and unplug the power cord. Clean and dry the interior thoroughly. To prevent odor and mold growth, leave the door open slightly: blocking it open if necessary.

➤ **Moving Your Wine/Beverage Cooler**

- Remove all items.
- Securely tape down all loose items (shelves) inside your Wine/Beverage Cooler.
- Turn the leveling screws up to the base to avoid damage.
- Tape the door shut.
- Be sure the Wine/Beverage Cooler stays secure in the upright position during transportation. Also protect outside of Wine/Beverage Cooler with a blanket, or similar item.

➤ **Energy Saving Tips**

- The Wine/Beverage Cooler should be located in the coolest area of the room, away from heat producing appliances, and out of the direct sunlight.

➤ **Interior Light**

- The light will be turned off automatically if it remains ON for 10 minutes. You have to push the button marked with the "bulb" symbol again and the light will turn back on.

PROBLEMS WITH YOUR WINE/BEVERAGE COOLER?

You can solve many common Wine/Beverage Cooler problems easily, saving you the cost of a possible service call. Try the suggestions below to see if you can solve the problem before calling the servicer.

TROUBLESHOOTING GUIDE

PROBLEM	POSSIBLE CAUSE
Wine/Beverage Cooler does not operate.	Not plugged in. The circuit breaker tripped or a blown fuse.
Turns on and off frequently.	The room temperature is hotter than normal. The door is opened too often. The door is not closed completely. The temperature control is not set correctly. The door gasket does not seal properly. The Wine/Beverage Cooler does not have the correct clearances.
Vibrations.	Check to assure that the Wine Cooler is level.
The Wine/Beverage Cooler seems to make too much noise.	The rattling noise may come from the flow of the refrigerant, which is normal. As each cycle ends, you may hear gurgling sounds caused by the flow of refrigerant in your Wine/Beverage Cooler. Contraction and expansion of the inside walls may cause popping and crackling noises. The Wine/Beverage Cooler is not level.
The door will not close properly.	The Wine/Beverage Cooler is not level. The door was reversed and not properly installed. The gasket is dirty. The shelves are out of position.

SERVICE FOR YOUR WINE/BEVERAGE COOLER

We are proud of our customer service organization and the network of professional service technicians that provide service on your Avanti Products appliances. With the purchase of your Avanti Products appliance, you can be confident that if you ever need additional information or assistance, the Avanti Products Customer Service team will be here for you. Just call us toll - free.

AVANTI PRODUCTS CUSTOMER SERVICES

Product Information 800 - 323 - 5029	Whatever your questions are about our products, help is available.
Part Orders 800 - 220 - 5570	You may order parts and accessories that will be delivered directly to your home by personal check, money order, Master Card, or Visa.
In - Home Repair Service 800 - 220 - 5570	An Avanti Products authorized service center will provide expert repair service, scheduled at a time that is convenient for you. Our trained servicers know your Wine/Beverage Cooler inside and out.

YOUR Avanti Products WARRANTY

Staple your sales receipt here. Proof of original purchase date is needed to obtain service under warranty.

WHAT IS COVERED**LIMITED ONE - YEAR WARRANTY**

For one year from the date of purchase by the original owner, Avanti Products will, at its option, repair or replace any part of the unit, which proves to be defective in material or workmanship under normal use. During this period Avanti Products will provide all parts and labor necessary to correct such defects free of charge, so long as the unit has been installed and operated in accordance with the written instructions in this manual. In rental or commercial use, the warranty period is 90 days. All Avanti/Avanti Products Appliances of 3.5 cubic foot capacity or less must be brought/sent to the appliance service shop for repair.

LIMITED SECOND THROUGH FIFTH YEAR WARRANTY

For the second through the fifth year from date of original purchase, Avanti Products will provide a replacement compressor free of charge due to a failure. You are responsible for the service labor and freight charges. In rental or commercial use, the limited compressor warranty is one year and nine months. Cost to move the unit to the servicers' shop and back to the user's home, as may be required, are the user's responsibility.

WHAT IS NOT COVERED

- Content losses of food due to spoilage.
- Incidental or consequential damages.
- Parts and labor costs for the following will not be considered as warranty:
 - Door springs, and/or frames.
 - Inner door panels, door rails and/or door supports.
 - Light bulbs and/or plastic housing.
 - Plastic cabinet liners.
 - Punctured evaporator that voids the warranty on the complete sealed system.
- Repairs performed by unauthorized servicers.
- Service calls that do not involve defects in material or workmanship such as customer education, door reversal, or proper installation.
- Service calls that are related to external problems, such as abuse, misuse, inadequate electrical power, accidents, fire, floods, or acts of God.
- Replacement of house fuses or resetting circuit breakers.
- Failure of the product if it is used for other than its intended purpose.
- This warranty does not apply outside the Continental USA.

WIRING DIAGRAM

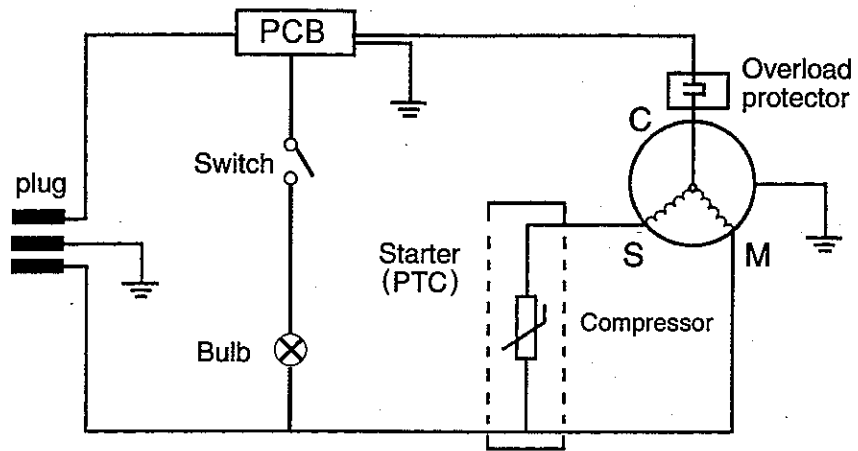

➤ **INSTALACION**

Retire los accesorios del empaque (plásticos protectores, cartón y tiras engomadas). Limpie el exterior con un trapo suave y seco, y el interior con un trapo húmedo y tibio.

➤ **UBICACION**

1. Seleccione un lugar con un piso firme y nivelado.
2. Su refrigerador requiere ventilación. Deje un espacio mínimo de 5" hacia arriba y espacio suficiente en el respaldo para permitir la circulación de aire.
3. Evite luz directa del sol o calor. La luz directa del sol puede afectar la capa de pintura. Las fuentes de calor en su proximidad causarán un consumo mayor de electricidad.
4. Para un mejor desempeño, nivele el refrigerador utilizando las patas ajustables o tornillos niveladores. Para verificar el nivel, abra la puerta hasta la mitad, debe regresar sola.

➤ **INSTRUCCIONES PARA LA CONEXION A TIERRA**

Este aparato electrodoméstico debe estar conectado a tierra. En caso de un cortocircuito eléctrico, la conexión a tierra reduce el riesgo de choque eléctrico proporcionando un cable de escape para la corriente eléctrica. Este aparato viene equipado con un cordón que posee un cable a tierra con un enchufe de conexión a tierra. Este enchufe debe estar conectado en un tomacorriente instalado correctamente y conectado a tierra.

➤ **ADVERTENCIA**

El uso inadecuado del enchufe de conexión a tierra puede resultar en un riesgo de choque eléctrico. Consulte con un electricista si no comprende bien las instrucciones de conexión a tierra o si existe alguna duda sobre si el aparato está conectado a tierra correctamente.

➤ **NO USE UN CORDON DE EXTENSION**

Use un tomacorriente de pared exclusivo. No conecte su refrigerador a cordones de prolongación eléctrica o junto a cualquier otro electrodoméstico en el mismo tomacorriente de pared.

➤ **ADVERTENCIA IMPORTANTE:**

Un refrigerador vacío es una atracción muy peligrosa para los niños. Quite los sellos magnéticos, puertas o cerraduras de todo electrodoméstico que esté en uso.

➤ OPERACION

Enchufe el cable a la toma de corriente, que debe ser 115 – 120v, 10 AMP ó más. Para evitar vibraciones, la caja debe estar bien nivelada. Al conectar su vinera por primera vez, puede haber una variante de varios grados entre la temperatura seleccionada y la indicada en la activación y desactivación. También hay una variante de 6°F a 8°F entre los estantes superiores e inferiores de la vinera, de forma que si usted quiere combinar una mezcla de vinos rojos (tintos) y blancos, deberá colocar las botellas de vino blanco en el estante inferior y las de vino tinto en el estante superior. Si usted ha programado el enfriador de vino a 15°C por ejemplo, podría aumentarlo oprimiendo el botón marcado **A** sucesivamente o podría bajarlo oprimiendo el botón marcado **D**.

También puede cambiar de grados centígrados a Fahrenheit, oprimiendo el botón marcado C/F. F° aparecerá en la pantalla de color rojo, C° aparecerá en la pantalla de color amarillo.

POSICIONES RECOMENDADAS PARA ENFRIAR EL VINO Y LA CERVEZA:

BEER:	Cerveza
SPARKL:	Vino Espumante
WHITE:	Vino Blanco/Seco
RED:	Vino Tinto

AVISO: CUANDO LLENE EL INTERIOR DE CERVEZAS O VINOS SE RECOMIENDA QUE UD COLOQUE LAS BOTELLAS DE VINO TINTO EN EL ESTANTE SUPERIOR Y LAS CERVEZAS EN EL ESTANTE DE ABAJO.

➤ CUIDADOS EN LOS PERIODOS DE AUSENCIA

- Para cortos períodos de ausencia (menos de 21 días) la unidad podrá quedar funcionando.
- En períodos de ausencia más largos, se aconseja dejar la unidad limpia y desconectada.
- Saque todo lo que tenga adentro de la unidad y haga y la limpieza general.
- Deje la puerta entreabierta para que penetre el aire y así evitar la formación de olores.

➤ ECONOMIA DE ENERGIA

- Evite dejar por mucho tiempo la puerta abierta.
- Evite aperturas frecuentes de la puerta.
- Coloque el botón de control de temperaturas en la posición adecuada.

➤ **SI USTED SE VA DE VACACIONES**

- Saque todos los artículos de la unidad si Ud. se va de vacaciones por un mes o más.
- Desconecte la unidad del tomacorriente y limpie bien.
- Deje la puerta abierta para evitar la formación de olores, condensación o moho.

➤ **SI USTED SE MUDA**

- Desconecte la unidad del tomacorriente y limpie la unidad bien.
- Saque todas las partes movibles y empaquételas para que no se muevan durante la transportación.
- Cierre la puerta de la unidad y séllela con cinta adhesiva.
- Asegúrese que la unidad va parada durante el viaje y cúbralo con una frazada.

➤ **COMO CAMBIAR LA DIRECCION DE APERTURA DE LA PUERTA**

En caso de que necesite cambiar el lado de apertura de la puerta, por favor consulte al servicio pos - venta de su localidad o al empleado que le vendió la unidad.

IRREGULARIDADES CON EL FUNCIONAMIENTO DEL REFRIGERADOR

EN CASO DE QUE NECESITE CAMBIAR EL LADO DE APERTURA DE LA PUERTA, POR FAVOR CONSULTE AL SERVICIO POS VENTA DE SU LOCALIDAD O AL EMPLEADO QUE LE VENDIO LA UNIDAD.

PROBLEMA	CAUSAS PROBABLES	SOLUCION
El electrodoméstico no funciona.	Falta de energía. Tomacorriente defectuoso. Control de temperaturas en la posición "OFF". Enchufe desconectado.	Verifique el fusible. Substitúyalo o arréglelo. Coloque el botón en la posición correcta. Conéctelo.
La refrigeración es insuficiente.	Botón de control de temperatura en la posición incorrecta. Elevada frecuencia de apertura de la puerta.	Observe las instrucciones. Evite abrir la puerta demasiado.
Ruidos anormales.	Expansión del gas en el evaporador. Tubos en contacto con gabinetes o paredes.	Normal. Aléjelos.

PRINTED IN CHINA

Free Manuals Download Website

<http://myh66.com>

<http://usermanuals.us>

<http://www.somanuals.com>

<http://www.4manuals.cc>

<http://www.manual-lib.com>

<http://www.404manual.com>

<http://www.luxmanual.com>

<http://aubethermostatmanual.com>

Golf course search by state

<http://golfingnear.com>

Email search by domain

<http://emailbydomain.com>

Auto manuals search

<http://auto.somanuals.com>

TV manuals search

<http://tv.somanuals.com>