



UHF PERFORMANCE SERIES **TRUE DIVERSITY SYSTEMS**

OWNER'S MANUAL

**411UDR • 511DRH
51HT • 51XT • 51BT**



AZDEN CORPORATION
147 New Hyde Park Road, P.O. Box 10
Franklin Square, NY 11010
516.328.7500 vox • 516.328.7506 fax
azdenus@azdencorp.com • www.azdencorp.com

Thank you for purchasing AZDEN'S "PERFORMANCE SERIES" wireless system. UHF wireless systems yield a better signal to noise ratio and improved frequency response over VHF systems. The UHF band is less crowded than VHF thus giving you less likelihood of interference. This manual covers the 411UDR and 511DRH receivers and the 51BT, 51XT and 51HT transmitters.

Receiver Descriptions: The 411UDR and 511DRH are crystal controlled, PLL synthesized receivers with 63 on-board user selectable frequencies with a range of 794MHz to approx. 806MHz. They are true diversity, containing two separate receivers, each operating on the same frequency. The transmitter's output signal is monitored constantly by a diversity circuit, which switches automatically to the receiver with the stronger RF signal. This allows wireless performance that is virtually dropout free, even under the most adverse conditions. Both receivers feature a 1/4-inch and XLR output jacks and volume adjustment.

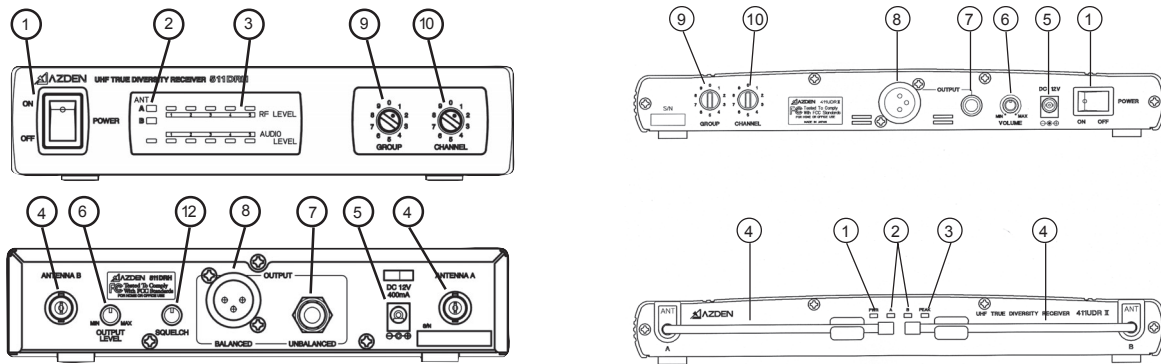

(1) Power LED and on/off switch (511DRH only)

After plugging in the 511DRH, depress the on/off switch to turn unit on. The 411UDR's Power LED will illuminate as soon as the unit is plugged in.

(2) Antenna A-B LED's

When the transmitter is turned on and is in reception range of the receiver, either the A or B LED will light up RED, depending on which receiver circuit is getting the strongest signal from the transmitter. Flickering between the A and B LED is a normal function of the system.

(3) Peak LED

These will flash if the audio component of the incoming signal is approaching distortion. The 511DRH has a 7 segment LED display to show the incoming audio signal from -20 to + 6 dB.

(4) Antennas, antenna connections

On both the 411UDR and 511DRH, position the antennas vertically for best reception. On the 411UDR, when not in use put the antennas in the holder to avoid damage. On the 511DRH the antennas are connector mounted (BNC) so that the supplied antennas can be disconnected and/or removed.

(5) 12 Volt Input

Plug the supplied AC adapter into the 12 volt input on the receiver then into an AC electrical outlet. Use only the adapter supplied, as other adapters may damage the receiver.

(6) Output Adjustment

Rotate this knob clockwise to increase, or counterclockwise to decrease volume level.

(7) Output (unbalanced)

Using a suitable audio cable (not supplied) connect the 1/4-inch phone jack end to the audio output on the receiver, and connect the other end of the cable to the suitable mic/line input of an audio mixer or amplifier.

(8) Output (balanced)

Using a suitable audio cable (not supplied) connect the XLR connector to the audio output on the receiver, and connect the other end of the cable to the suitable mic/line input of an audio mixer or amplifier.

(9) & (10) Frequency select

The group knob (9) allows you to select any of seven frequency groups (numbered from 0-6). The channel knob (10) allows you to select any of nine frequency channels (numbered 0-8) within the selected group. Any receiver/transmitter pair must be on the same group and frequency to operate properly. Be sure that both the transmitter and the receiver are OFF before selecting/changing the frequency.

When using more than one system, all receivers and transmitters must be set to the same group to avoid intermodulation distortion while all transmitter/receiver pair must be on different frequencies.

(11) Rack ears

If you wish to use one or two of the 511DRH in a standard 19" rack you must attach the rack ears (HR-1 or HR-2 – purchased separately) by attaching the ears with the four machine screws (two per side near front). The HR-2 also requires the attachment of a joining plate underneath the two units.

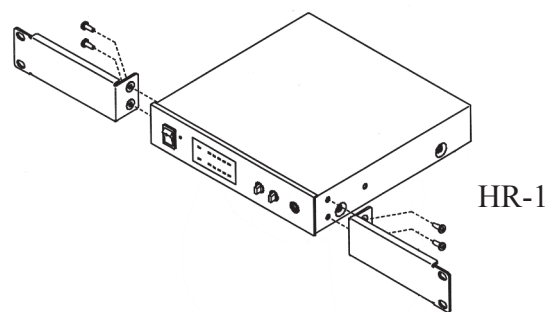

(2)

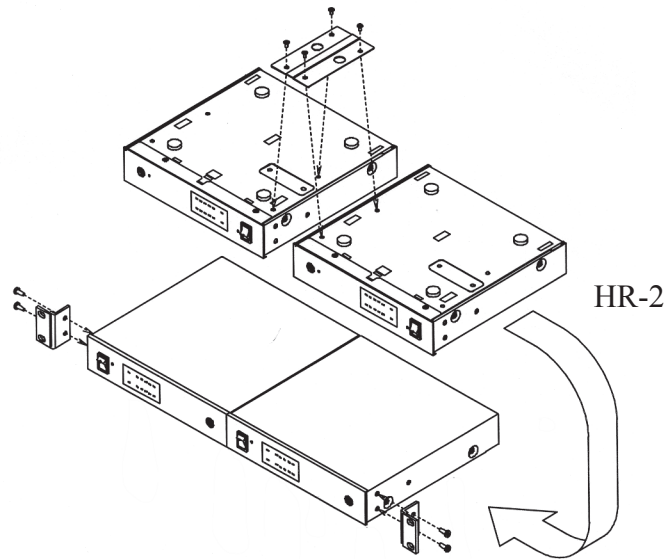

The following feature is for the 511DRH only.

(12) Squelch adjust

This adjusts the point at which the receiver will shut off or “squelch” the incoming radio signal when it becomes too weak. Turning the control clockwise raises the threshold, allowing more signal to enter, and turning the control counterclockwise lowers the threshold, letting in less signal.

When operating multiple systems all receivers and transmitters must be on the same group

Example: 4 systems operating simultaneously.

	System #1		System #2		System #3		System #4	
	Group	Channel	Group	Channel	Group	Channel	Group	Channel
Receivers	2	4	2	5	2	6	2	7
Transmitters	2	4	2	5	2	6	2	7

To change the frequency that a transmitter, receiver pair is already on
YOU MUST FIRST TURN OFF BOTH THE TRANSMITTER AND RECEIVER!

Transmitter Descriptions:

51HT Handheld microphone transmitter with 63 on-board user selectable UHF frequencies. Ideal for all vocal applications.

(1) To install batteries, turn the bottom half of the mic case counterclockwise until it is completely off.

(2) Insert two fresh alkaline “AA” batteries into the compartment. Make sure battery polarity is correct.

(3) Frequency select

The group knob allows you to select any of seven frequency groups (numbered from 0-6). The channel knob allows you to select any of nine frequency channels (numbered 0-8) within the selected group.

Replace bottom half of microphone case and turn clockwise until snug. **DO NOT OVER TIGHTEN.**

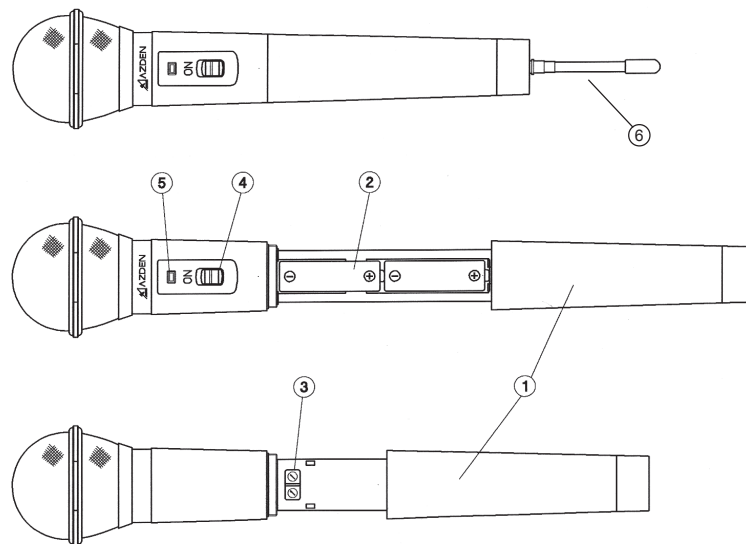

(4) 2 Position switch

The bottom position is “Off” and the top position is “On”. Turning the transmitter Off will cause the receiver to mute due to the tone squelch circuitry at the receiver. This allows the mic to be handled with no noise.

(5) LED Indicator turns green when turned on. This LED will also turn red to indicate that the battery level is low and the batteries must be changed.

(6) The antenna attaches to the bottom of the microphone. It is screwed on clockwise and should be snug.

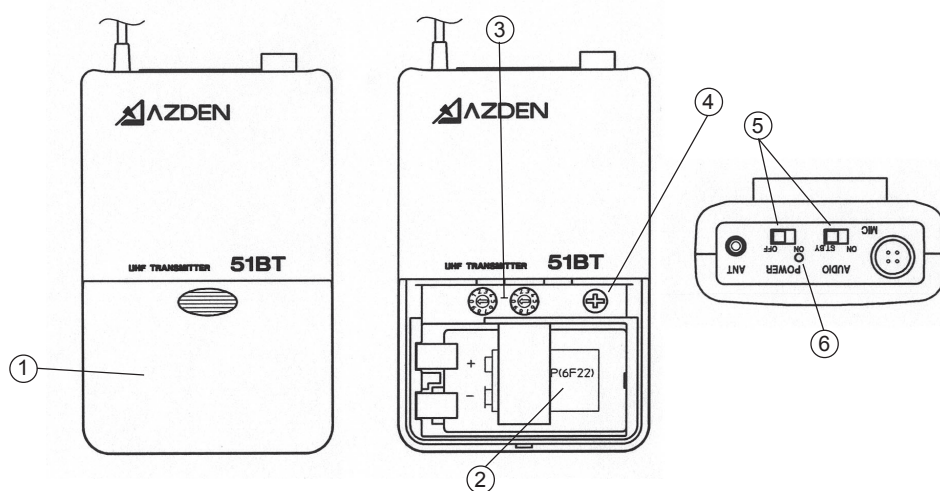

The **51BT** body-pack transmitter has 63 user selectable UHF frequencies and is ideal for lavalier and headset microphones. The optional MP-1H instrument cable allows the 51BT to work with electric guitars and basses.

(1) Open the battery compartment lid by sliding it down and raising it.

(2) Insert one fresh alkaline 9-volt battery into the compartment. Make sure battery polarity is correct.

(3) Frequency select:

The group knob (left) allows you to select any of seven frequency groups (numbered from 0-6). The channel knob (right) allows you to select nine frequency channels (numbered 0-8) within the selected group. Use the flat end of the provided tool to adjust these settings.

(4) Audio input Level Control:

Enables you to adjust the input level of the microphone or musical instrument. Turn clockwise to increase, or counterclockwise to decrease the input level. Use the + end of the provided tool to adjust this setting. The level control is factory-preset in the center position.

(5) Power and standby switches:

The power “On” and “Off” switch enables and disables all transmitter functions while the audio switch “On” and “Standby” turn the audio off and on. Switching the transmitter to “Standby” will cause the receiver to mute using the tone squelch circuitry in the receiver. This allows the microphone to be handled with no noise.

(6) LED Indicator:

Turns green when the transmitter is turned on. This LED will also turn red to indicate that battery level is low and the battery must be changed.

(5)

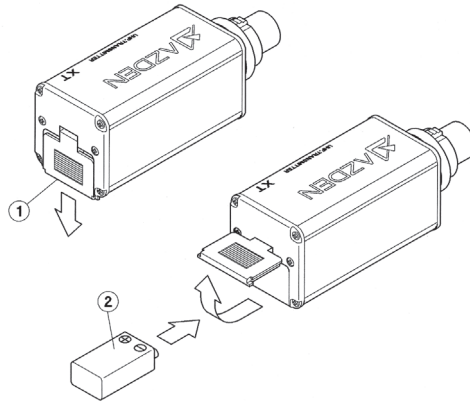

51XT plug-in XLR transmitter with 63 on-board user selectable UHF frequencies. Ideal for use with dynamic microphones with XLR output.

(1) Open the battery compartment lid by sliding it down and raising it

(2) Insert one fresh alkaline 9-volt battery into the compartment. Make sure battery polarity is correct.

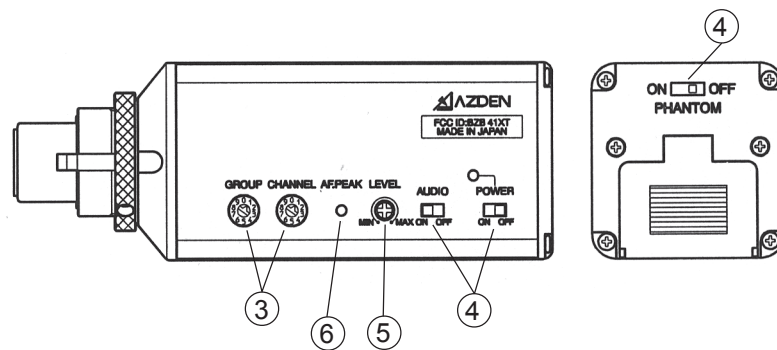

(3) Frequency select

The group knob allows you to select any of seven frequency groups (numbered from 0-6). The channel knob allows you to select any of nine frequency channels (numbered from 0-8) within the selected group.

(4) Power and Audio switches

The power “On/Off” switch enables and disables all transmitter functions while the Audio “On/Off” switch turns just the transmitter’s Audio signal on and off. Switching the Audio to “Off” will cause the receiver to mute using the tone squelch circuitry in the receiver. This allows the microphone to be handled with no noise. The “Phantom” switch allows the 51XT to provide 5V to power electret condenser microphones.

(5) Audio input LEVEL control

This enables you to adjust the input level of the microphone. Turn clockwise to increase, or counterclockwise to decrease the input level. A small screwdriver is supplied to make adjustments.

(6)

(6) LED INDICATORS

The POWER LED turns green when power is turned “On” or red if battery level is low. If this LED lights up red replace the battery.

The AF PEAK LED lights up if the input level is set to high, indicating the onset of distortion. Lower the input level so that the AF PEAK LED lights only occasionally.

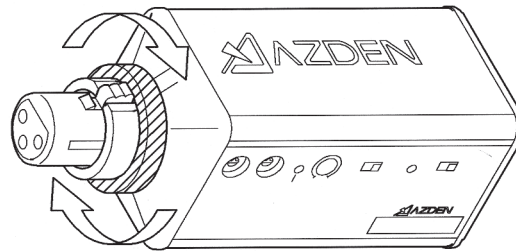

To plug the 51XT onto a microphone (low impedance with XLR connector) first make certain the locking-ring is turned fully up (rotate counterclockwise). Then plug the 51XT fully into the microphone's XLR connector and tighten by rotating the ring fully down (clockwise).

OPERATING THE SYSTEM:

Because this is a frequency agile system, meaning that you choose the frequency of both the transmitter and receiver via the group and channel controls, we cannot stress enough that any transmitter/receiver pair that you want to transmit and receive on **MUST BE SET TO THE SAME FREQUENCY!**

Additionally, multiple systems used in the same proximity must **ALL BE ON THE SAME GROUP SELECTION!** To change the frequency that a transmitter/receiver pair is already on **YOU MUST TURN OFF BOTH TRANSMITTER AND RECEIVER FIRST!**

Do not place the receiver on a metal surface, and avoid obstructions between the receiver and transmitter, since this could degrade the performance of the equipment.

First, make sure that the power to all your components is turned off. Connect an audio cable from the output of the receiver (phone jack or XLR) to a mic/line input on your audio mixer or amplifier. Plug the receiver's AC adapter into the 12V input jack on the receiver and then plug it into the AC electrical outlet. With the volume of your mixer or amplifier set to minimum level, turn your system's power on. Turn on the transmitter(s). Make sure all LEDs on the receiver(s) and transmitter(s) are operating as described in the preceding pages. Now set the receiver's volume to the midway point and adjust the volume level on your mixer or amplifier.

51BT with Lavalier or Headset:

With someone talking into the microphone, turn the volume on the mixer or amplifier to the desired level. If there is too much, or not enough gain, lower or raise the volume on the receiver. If the sound is distorted, lower the input gain on the transmitter.

51BT with Instrument cable for electric guitars or basses (MP-1H):

Plug the cable into the guitar or bass. Set the instrument volume to the midway point. While playing the instrument, turn the volume on the mixer or amplifier to the desired level. If there is too much, or not enough gain, lower or raise the volume on the receiver. If the sound is distorted, lower the input gain (4) on the transmitter.

51XT: With someone talking into the microphone, turn the volume on the mixer or amplifier to the desired level. If there is too much, or not enough gain, lower or raise the volume on the receiver. If the sound is distorted, lower the input gain on the transmitter.

51HT:

With someone talking/singing into the microphone, turn the volume on the mixer/amplifier to the desired level. If there is too much, or too little gain, adjust the volume on the receiver. If the sound is distorted, move the microphone further away from the sound source. Make sure that the LED is green when the mic/transmitter is turned On. When the battery is low, the LED turns red indicating that the battery needs to be changed.

NOTES:

- All “Performance Series” transmitters will work continuously for approximately 6-8 hours using an alkaline battery.
- Remove the battery if the transmitter will not be used for a long period of time.
- Do not use or store the system in areas of high temperatures or humidity.
- Do not use this system near a broadcast station, airport, or airplanes, it may cause interference. If you are interfering with other transmissions you must turn off the system.
- These systems contain no user serviceable parts. If unauthorized service is performed it may void the warranty.

Specifications

Overall:

Frequency Range: UHF 63 ch. (793-806MHz)

Frequency Response: 20Hz to 20kHz

Audio Distortion: less than 1%

Dynamic Range: better than 100dB

S/N Ratio: better than 95dB

Operating Temperatures: 0 to 45

Operating Range: 100m under ideal conditions

Oscillator: PLL synthesized

Tone Squelch Frequency: 32.768kHz

Diversity Type: True Space Diversity

51BT Transmitter:

Type of Emission: FM

Antenna: External Antenna

Pre-emphasis: 50 μ s

MAX Input Level: -10dBm(Mic) +7dBm(MP-1)

Microphone Unit: Lav or Headset

RF Output Power: 15mW (50mW MAX)

Input Impedance: 2.2K (Mic) 680K (MP-1H)

Audio Adj Range: -65dBm ~ -37dBm

Battery: 9V

Battery Life: 6 to 8 hours with Alkaline Battery

Dimensions: 100(H) 64(W) 27(D) mm

Weight: 127.5g (without battery)

FCC Notes:

These systems conform to part 74 and part 15 of the FCC rules, and you should contact the FCC office for filing forms.

51HT Transmitter:

Type of Emission: FM

Antenna: Internal Antenna

Microphone Unit: Unidirectional Dynamic

RF Output Power: 10m W (50mW MAX)

Input Impedance: 8K

Battery: 2 1.5V (AA)

Battery Life: 6 to 8 Hours with Alkaline Battery

Dimensions: 56(D) 242(L) mm

Weight: 250g (without battery)

51XT Transmitter:

Type of Emission: FM

Antenna: Internal Antenna

Pre-emphasis: 50 μ s

MAX Input Level: -7dBm

Microphone Unit: Dynamic Microphones

RF Output Power: 15mW (50mW MAX)

Input Impedance: 6K

Audio Adj Range: -63dBm ~ -18dBm

Battery: 9V

Battery Life: 6 to 8 hours with Alkaline Battery

Dimensions: 40 x 40 x 99(L) mm

Weight: 152g (without battery)

UHF FREQUENCY CHART

GRP	C H A N N E L								
	0	1	2	3	4	5	6	7	8
0	794.500	795.750	797.750	798.000	799.500	800.500	802.375	804.7850	805.875
1	794.375	795.625	797.625	797.875	799.375	800.375	802.250	804.625	805.750
2	793.750	795.000	797.000	797.250	798.750	799.750	801.625	804.000	805.125
3	794.250	795.500	797.500	797.750	799.250	800.250	802.125	804.500	805.625
4	794.125	795.375	797.375	797.625	799.250	800.125	802.000	804.375	805.500
5	794.000	795.250	797.250	797.500	799.000	800.000	801.875	804.250	805.375
6	793.875	795.125	797.125	797.375	798.875	799.875	801.750	804.125	805.250

Free Manuals Download Website

<http://myh66.com>

<http://usermanuals.us>

<http://www.somanuals.com>

<http://www.4manuals.cc>

<http://www.manual-lib.com>

<http://www.404manual.com>

<http://www.luxmanual.com>

<http://aubethermostatmanual.com>

Golf course search by state

<http://golfingnear.com>

Email search by domain

<http://emailbydomain.com>

Auto manuals search

<http://auto.somanuals.com>

TV manuals search

<http://tv.somanuals.com>